

ROCK MASS CLASSIFICATION

A Practical Approach
in Civil Engineering

B. Singh
R.K. Goel

ELSEVIER

www.EngineeringBooksPDF.com

ROCK MASS CLASSIFICATION

A Practical Approach
in Civil Engineering

ELSEVIER SCIENCE INTERNET HOMEPAGE

<http://www.elsevier.nl> (Europe)

<http://www.elsevier.com> (America)

<http://www.elsevier.co.jp> (Asia)

Full catalogue information on all books, journals and electronic products.

ELSEVIER TITLES OF RELATED INTEREST

Engineering Rock Mechanics: An Introduction to Principles

John A. Hudson & John P. Harrison

ISBN: 0080419127

Engineering Rock Mechanics II: Worked Examples

John P. Harrison & John A. Hudson

(forthcoming)

Deformation and Progressive Failure in Geomechanics

Ed. A. Asaoka, T. Adachi, F. Oka

ISBN: 008042838X

NARMS'98: Proceedings of the 3rd North American Rock Mechanics Symposium

Ed. J. Orozco, J. Schmitter

ISBN: 008043332

RELATED JOURNALS

Free specimen copy gladly sent on request: Elsevier Science Ltd, The Boulevard, Langford Lane, Kidlington, Oxford, OX5 1GB, UK

International Journal of Rock Mechanics and Mining Sciences

Soil Dynamics and Earthquake Engineering

Computers and Geotechnics

Geotextiles and Geomembranes

Tunnelling and Underground Space Technology

Trenchless Technology Research

Journal of Terramechanics

Engineering Failure Analysis

Probabilistic Engineering Mechanics

Reliability Engineering & System Safety

Structural Safety

TO CONTACT THE PUBLISHER

Elsevier Science welcomes enquiries concerning publishing proposals; books, journals, special issues, conference proceedings etc. All formats and media can be accommodated.

Should you have a publishing proposal you wish to discuss, please contact, without obligation, the publisher responsible for Elsevier's civil and structural engineering publishing programme;

Dr. Jim Hough

Publishing Editor

Materials Science and Engineering

Elsevier Science Ltd

The Boulevard, Langford Lane

Kidlington, Oxford,

OX5 1GB UK

Phone: +44 (0)1865 843879

Fax: +44 (0)1865 843920

E-mail: j.hough@elsevier.co.uk

General enquiries including placing orders, should be directed to Elsevier's Regional Sales Offices- please access the Elsevier homepage for full contact details.

ROCK MASS CLASSIFICATION

A Practical Approach
in Civil Engineering

Bhawani Singh

University of Roorkee,
Roorkee, India

&

R.K. Goel

Central Mining Research Institute
Roorkee, India

1999



ELSEVIER

Amsterdam – Lausanne – New York – Oxford – Shannon – Singapore – Tokyo

ELSEVIER SCIENCE Ltd
The Boulevard, Langford Lane
Kidlington, Oxford OX5 1GB, UK

© 1999 Elsevier Science Ltd. All rights reserved.

This work is protected under copyright by Elsevier Science and the following terms and conditions apply to its use:

Photocopying

Single photocopies of single chapters may be made for personal use as allowed by national copyright laws. Permission of the publisher and payment of a fee is required for all other photocopying, including multiple or systematic copying, copying for advertising or promotional purposes, resale, and all forms of document delivery. Special rates are available for educational institutions that wish to make photocopies for non-profit educational classroom use.

Permissions may be sought directly from Elsevier Science Rights & Permissions Department, PO Box 800, Oxford OX5 1DX, UK; phone: (+44) 1865 843830, fax: (+44) 1865 853333, e-mail: permissions@elsevier.co.uk. You may also contact Rights & Permissions directly through Elsevier's home page (<http://www.elsevier.nl>), selecting first 'Customer Support', then 'General Information', then 'Permissions Query Form'.

In the USA, users may clear permissions and make payments through the Copyright Clearance Center, Inc., 222 Rosewood Drive, Danvers, MA 01923, USA; phone: (978) 7508400, fax: (978) 7504744, and in the UK through the Copyright Licensing Agency Rapid Clearance Service (CLARCS), 90 Tottenham Court Road, London W1P 0LP, UK; phone: (+44) 171 436 5931; fax: (+44) 171 436 3986. Other countries may have a local reprographic rights agency for payments.

Derivative Works

Tables of contents may be reproduced for internal circulation, but permission of Elsevier Science is required for external resale or distribution of such material.

Permission of the publisher is required for all other derivative works, including compilations and translations.

Electronic Storage or Usage

Permission of the publisher is required to store or use electronically any material contained in this work, including any chapter or part of a chapter. Contact the publisher at the address indicated.

Except as outlined above, no part of this work may be reproduced, stored in a retrieval system or transmitted in any form or by any means, electronic, mechanical, photocopying, recording or otherwise, without prior written permission of the publisher.

Address permissions requests to: Elsevier Science Rights & Permissions Department, at the mail, fax and e-mail addresses noted above.

Notice

No responsibility is assumed by the Publisher for any injury and/or damage to persons or property as a matter of products liability, negligence or otherwise, or from any use or operation of any methods, products, instructions or ideas contained in the material herein. Because of rapid advances in the medical sciences, in particular, independent verification of diagnoses and drug dosages should be made.

This book has been reproduced in its entirety directly from the authors original manuscript.

First edition 1999

Library of Congress Cataloging in Publication Data

A catalog record from the Library of Congress has been applied for.

British Library Cataloguing in Publication Data

A catalogue record from the British Library has been applied for.

ISBN: 0 08 043013 9

Ⓢ The paper used in this publication meets the requirements of ANSI/NISO Z39.48-1992 (Permanence of Paper).
Printed in The Netherlands.

Dedicated to
Researchers and Readers

PREFACE

The growing need for this book "*Rock Mass Classifications - A Practical Approach in Civil Engineering*" has been the authors' motivation for many years. Many questions agitated our minds - Is Classification reasonably reliable? Can it be successful in the crisis management of geohazards? Can a single Classification system be general for all rock structures? Is Classification a scientific approach? Laborious field research was needed to find answers to these vital questions. By God's grace, scientists of the Central Mining Research Institute (CMRI), University of Roorkee (UOR), Central Soil and Material Research Station (CSMRS), U. P. Irrigation Research Institute (UPIRI), and Norwegian Geotechnical Institute (NGI) came together. The god gifted ideas and the reliable field data made our task of interpretation less tortuous. Consequently, several improvements in correlations have been possible and thereby practical doubts were cleared. Then followed the consultancy works in above institutions, the success of which further boosted our morale. Finally, the research work was systematically compiled into this book in order to generate more confidence and interest among civil, mining and petroleum engineers and geologists.

Research experience suggests that many classification approaches are scientific. Nevertheless, the scientific spirit of prediction, check and cross-check should be kept alive. Hence, many alternative classification systems have been presented for a particular rock structure. The suggested correlations in this book may be used in feasibility designs of major projects. For final designs, rational approaches are recommended. In the design of minor projects, field correlations may be used. The notation for uniaxial compressive strength of rock material is q_c and σ_c in this book.

Rational approaches are becoming popular in consultancy on major projects. Our goal should be to develop a reliable engineering strategy/solution for geological problems and not rigorous analysis. This should remove the prevailing dissatisfaction present in the minds of designers. Thus, computer modelling may be the future trend of research at this point of time.

It appears that field testing and monitoring may always be the key approach in Rock Engineering Projects. All practical knowledge has been gained from interpretations of field observations.

Himalaya provides the best field laboratory to learn Rock Mechanics and Engineering Geology because of its complex geological problems. Further, the hypnotic charm of upper Himalaya is very healing especially to concerned engineers and geologists. Natural oxygenation processes exist on the hill tracks which charge our whole nervous system and give a marvellous feeling of energy and inner healing. So working in majestic Himalaya is a twin boon.

The authors foremost wish is to express their deep gratitude to Professor Charles Fairhurst, University of Minnesota, Dr. N. Barton, NGI, Professor J. A. Hudson, Imperial College of Science and Technology, London, Professor E. Hoek, International Consulting Engineer, Professor J. J. K. Daemen, University of Nevada, Dr. E. Grimstad, NGI, Professor G. N. Pandey, University of Swansea, Professor J. Nedoma, Academy of Sciences of Czech

Republic, Professor V. D. Choubey, Regional Engineering College, Hamirpur, Dr. B. Singh, Banaras Hindu University (BHU), Professor B. B. Dhar, BHU, Dr. T. N. Singh, CMRI, Dr. N. M. Raju, National Institute of Rock Mechanics, Kolar, Dr. A. K. Dube, CMRI, Dr. J. L. Jethwa, CMRI, Dr. V. M. Sharma, ATEs, Professor Gopal Ranjan, UOR, Professor P. K. Jain, UOR, Dr. M. N. Viladkar, UOR, Dr. A. K. Dhawan, CSMRS, Dr. V. K. Mehrotra, UPIRI, Dr. Subhash Mitra, UPIRI, Mr N. K. Samadhiya, UOR and Mr. H. S. Niranjana, HBTI for their constant moral support and vital suggestions and for freely sharing precious field data. The authors are also grateful to the scientists of CMRI, CSMRS, UPIRI and UOR and all project authorities for supporting field researches.

The authors also thank Elsevier Science, U. K., A. A. Balkema, Netherlands, American Society of Civil Engineers (ASCE), Reston, Ellis Horwood, U.K., Institution of Mining & Metallurgy, London, John Wiley & Sons, Inc., New York, Springer-Verlag, Germany, Trans Tech, Germany, and Van Nostrand Reinhold, New York, for the kind permission and also to all eminent researchers whose work is referred in the book.

All enlightened engineers and geologists are requested to kindly send their precious suggestions for improving the book to the authors.

Bhawani Singh
*Professor of Civil Engineering,
University of Roorkee,
Roorkee - 247 667, India*

R. K. Goel
*Central Mining Research Institute
(Regional Centre) CBRI Campus,
Roorkee - 247 667 India*

CONTENTS

| | |
|--|-----------|
| Preface | vi |
| CHAPTER 1 - PHILOSOPHY OF QUANTITATIVE CLASSIFICATIONS | 1 |
| 1.1 The Classification | 1 |
| 1.2 Philosophy of Classification System | 2 |
| 1.3 Management of Uncertainties | 2 |
| 1.4 Present Day Practice | 3 |
| 1.5 Scope of the Book | 4 |
| CHAPTER 2 - SHEAR ZONE TREATMENT IN TUNNELS AND FOUNDATIONS | 5 |
| 2.1 Shear Zone | 5 |
| 2.2 Treatment for Tunnels | 5 |
| 2.3 Treatment for Dam Foundations | 7 |
| CHAPTER 3 - ROCK MATERIAL | 10 |
| 3.1 Rock Material | 10 |
| 3.3 Classification of Rock Material | 12 |
| 3.4 Class I and II Rocks | 12 |
| 3.5 Uniaxial Compression | 13 |
| 3.6 Stability in Water | 15 |
| 3.7 Classification on the Basis of Slake Durability Index | 15 |
| CHAPTER 4 - ROCK QUALITY DESIGNATION | 17 |
| 4.1 Rock Quality Designation (RQD) | 17 |
| 4.2 Direct Method | 17 |
| 4.3 Indirect Methods | 18 |
| 4.3.1 Seismic Method | 18 |
| 4.3.2 Volumetric Joint Count | 19 |
| 4.4 Weighted Joint Density | 20 |
| 4.4.1 Surface Measurement | 21 |
| 4.4.2 Drillhole Measurements | 22 |
| CHAPTER 5 - TERZAGHI'S ROCK LOAD THEORY | 25 |
| 5.1 Introduction | 25 |
| 5.2 Rock Classes | 25 |
| 5.3 Rock Load Factor | 25 |
| 5.4 Modified Terzaghi's Theory for Tunnels and Caverns | 31 |

| | |
|---|------------|
| 9.3 Prediction of Ground Conditions | 96 |
| 9.4 Prediction of Support Pressure | 96 |
| 9.5 Effect of Tunnel Size on Support Pressure | 99 |
| 9.5.1 Review of Existing Approaches | 99 |
| 9.5.2 New Concept on Effect of Tunnel Size on Support Pressure | 101 |
| 9.6 Correlations for Estimating Tunnel Closure | 101 |
| 9.7 Effect of Tunnel Depth on Support Pressure and Closure in Tunnels | 102 |
| 9.8 Approach for Obtaining Ground Reaction Curve (GRC) | 103 |
| 9.9 Coefficient of Volumetric Expansion of Failed Rock Mass | 105 |
| | |
| CHAPTER 10 -ROCK MASS INDEX | 108 |
| 10.1 Introduction | 108 |
| 10.2 Selection of Parameters used in R _{Mi} | 108 |
| 10.3 Calibration of R _{Mi} from Known Rock Mass Strength Data | 109 |
| 10.4 Scale Effect | 111 |
| 10.5 Examples (Palmstrom, 1995) | 115 |
| 10.6 Applications of R _{Mi} | 116 |
| 10.7 Benefits of Using R _{Mi} | 117 |
| 10.8 Limitations of R _{Mi} | 117 |
| | |
| CHAPTER 11 -RATE OF TUNNELLING | 120 |
| 11.1 Introduction | 120 |
| 11.2 Classification of Ground/Job Conditions for Rate of Tunnelling | 121 |
| 11.3 Classification of Management Conditions for Rate of Tunnelling | 121 |
| 11.4 Combined Effect of Ground and Management Conditions on Rate of Tunnelling | 126 |
| | |
| CHAPTER 12 -SUPPORT SYSTEM IN CAVERNS | 128 |
| 12.1 Support Pressure | 128 |
| 12.2 Wall Support in Caverns | 129 |
| 12.3 Roof Support in Caverns | 131 |
| 12.4 Stress Distribution in Caverns | 133 |
| 12.5 Opening of Discontinuities in Roof Due to Tensile Stress | 133 |
| 12.6 Rock Reinforcement Near Intersections | 133 |
| 12.7 Radial Displacements | 134 |
| 12.8 Precautions | 134 |
| | |
| CHAPTER 13 -STRENGTH ENHANCEMENT OF ROCK MASS IN TUNNELS | 136 |
| 13.1 Causes of Strength Enhancement | 136 |
| 13.2 Effect of Intermediate Principal Stress on Tangential Stress at Failure in Tunnels | 136 |
| 13.3 Uniaxial Compressive Strength of Rock Mass | 139 |
| 13.4 Reason for Strength Enhancement in Tunnels and A Suggested New Failure | |

| | |
|---|-----|
| Theory | 141 |
| 13.4.1 Failure of Laminated Rock Mass | 142 |
| 13.5 Criterion for Squeezing of Rock Masses | 143 |
| 13.6 Tensile Strength Across Discontinuous Joints | 143 |
| 13.7 Dynamic Strength of Rock Mass | 144 |
| 13.8 Residual Strength Parameters | 146 |
| | |
| CHAPTER 14 -STRENGTH OF DISCONTINUITIES | 148 |
| 14.1 Introduction | 148 |
| 14.2 Joint Wall Roughness Coefficient (JRC) | 148 |
| 14.2.1 Relationship Between J_r and JRC Roughness Descriptions | 150 |
| 14.3 Joint Wall Compressive Strength (JCS) | 150 |
| 14.4 Joint Matching Coefficient (JMC) | 154 |
| 14.5 Angle of Internal Friction | 154 |
| 14.6 Shear Strength of Joints | 155 |
| | |
| CHAPTER 15 -SHEAR STRENGTH OF ROCK MASSES IN SLOPES | 158 |
| 15.1 Mohr-Coulomb Strength Parameters | 158 |
| 15.2 Non-Linear Failure Envelopes for Rock Masses | 158 |
| 15.3 Strength of Rock Masses in Slopes | 162 |
| 15.4 Back Analysis of Distressed Slopes | 162 |
| | |
| CHAPTER 16 -TYPES OF ROCK SLOPE FAILURES | 164 |
| 16.1 Introduction | 164 |
| 16.2 Planar (Translational) Failure | 164 |
| 16.3 3D Wedge Failure | 164 |
| 16.4 Circular (Rotational) Failure | 164 |
| 16.5 Toppling Failure (Topples) | 166 |
| 16.6 Ravelling Slopes (Falls) | 167 |
| 16.7 Effect of Height and Ground Water Conditions on Safe Slope Angle | 169 |
| 16.8 Landslide Classification System | 169 |
| | |
| CHAPTER 17 -SLOPE MASS RATING (SMR) | 171 |
| 17.1 The Slope Mass Rating (SMR) | 171 |
| 17.3 Support Measures | 175 |
| 17.4 Modified SMR Approach | 176 |
| 17.5 Case Study of Stability Analysis Using Modified SMR Approach | 178 |
| | |
| CHAPTER 18 -LANDSLIDE HAZARD ZONATION | 184 |
| 18.1 Introduction | 184 |
| 18.2 Landslide Hazard Zonation Maps - The Methodology | 185 |
| 18.3 A Case History | 190 |

| | |
|---|------------|
| 18.4 Proposition for Tea Gardens | 199 |
| CHAPTER 19 -ALLOWABLE BEARING PRESSURE FOR BUILDING FOUNDATIONS | 200 |
| 19.1 Introduction | 200 |
| 19.2 Classification for Net Safe Bearing Pressure | 200 |
| 19.3 Allowable Bearing Pressure | 201 |
| 19.4 Coefficient of Elastic Uniform Compression for Machine Foundations | 205 |
| CHAPTER 20 -METHOD OF EXCAVATION | 207 |
| 20.1 Excavation Techniques | 207 |
| 20.2 Assessing the Rippability | 207 |
| 20.3 Rock Mass Classification According to Ease of Ripping | 208 |
| 20.4 Empirical Methods in Blasting | 210 |
| CHAPTER 21 -ROCK DRILLABILITY | 213 |
| 21.1 Drillability and Affecting Parameters | 213 |
| 21.2 Classification for Drilling Condition | 215 |
| 21.3 Other Approaches | 217 |
| CHAPTER 22 -PERMEABILITY AND GROUTABILITY | 219 |
| 22.1 Permeability | 219 |
| 22.2 Permeability of Various Rock Types | 219 |
| 22.3 Permeability for Classifying Rock Masses | 220 |
| 22.4 Permeability vs Grouting | 221 |
| 22.5 Determination of Permeability | 221 |
| 22.6 Grouting | 222 |
| CHAPTER 23 -GOUGE MATERIAL | 230 |
| 23.1 Gouge | 230 |
| 23.2 Influence of Gouge Material | 231 |
| 23.3 Shear Strength of Filled Discontinuities (Silty to Clayey Gouge) | 234 |
| 23.4 Dynamic Strength | 235 |
| CHAPTER 24 -ENGINEERING PROPERTIES OF HARD ROCK MASSES | 237 |
| 24.1 Hard Rock Masses | 237 |
| 24.2 Modulus of Deformation | 237 |
| 24.3 Uniaxial Compressive Strength (UCS) | 237 |
| 24.4 Uniaxial Tensile Strength (UTS) | 238 |
| 24.5 Strength Criterion | 238 |
| 24.6 Support Pressure in Non-squeezing/Non-Rock Burst Conditions | 239 |
| 24.7 Half - Tunnels | 239 |

| | |
|---|---------|
| CHAPTER 25 -GEOLOGICAL STRENGTH INDEX (GSI) | 242 |
| 25.1 Geological Strength Index (GSI) | 242 |
| 25.2 Modified Strength Criterion | 243 |
| 25.3 Mohr-Coulomb Strength Parameters | 245 |
| 25.4 Modulus of Deformation | 247 |
| 25.5 Selection of Rock Parameters for Intact Schistose | 247 |
| CHAPTER 26 -EVALUATION OF CRITICAL ROCK PARAMETERS | 250 |
| 26.1 Introduction | 250 |
| 26.2 Critical Parameters | 250 |
| 26.3 Parameter Intensity and Dominance | 251 |
| 26.3.1 Generic Matrix Coding | 251 |
| 26.3.2 The Cause-Effect Plot | 251 |
| 26.4 Classification of Rock Mass | 253 |
| 26.5 Example for Studying Parameter Dominance in Underground Excavation for a Coal Mine with Flat Roof | 254 |
| 26.6 Relative Importance of Rock Parameters in Major Projects | 256 |
| 26.7 Application in Entropy Management | 256 |
| CHAPTER 27 -INSITU STRESSES | 258 |
| 27.1 Need for Insitu Stress Measurement | 258 |
| 27.2 Classification of Geological Conditions and Stress Regimes | 258 |
| 27.3 Variation of Insitu Stresses with Depth | 260 |
| Author Index | 263 |
| Subject Index | 265 |

This Page Intentionally Left Blank

CHAPTER - 1

PHILOSOPHY OF QUANTITATIVE CLASSIFICATIONS

"When you can measure what you are speaking about, and express it in numbers, you know something about it, but when you can not measure it, when you can not express it in numbers, your knowledge is of a meagre and unsatisfactory kind; it may be the beginning of knowledge, but you have scarcely in your thoughts, advanced to the stage of science"

Lord Kelvin

1.1 The Classification

The science of classification is called taxonomy, which deals with theoretical aspects of classification, including its basis, principles, procedures and rules.

Rock mass classifications form the back bone of the empirical design approach and are widely employed in rock engineering. The rock mass classifications have recently been quite popular and being used in feasibility designs. It has been experienced repeatedly that when used correctly, a rock mass classification can be a powerful tool in designs. Infact, on many projects, the classification approach serves as the only practical basis for the design of complex underground structures. The Gjovik Underground Ice Hockey Stadium of 60m width in Norway was also designed by the classification approach.

Quantitative rock mass classification systems have been used with great benefit in Austria, South Africa, USA, Europe and India due to the following reasons:

- (i) It provides better communication between geologists, designers, contractors and engineers;
- (ii) Engineer's observations, experience and judgment are correlated and consolidated more effectively by a quantitative classification system;
- (iii) Engineers prefer numbers in place of descriptions, hence, a quantitative classification system has considerable application in an overall assessment of the rock quality; and
- (iv) Classification approach helps in the organization of knowledge.

The classification systems in the last 50 years of its development have taken cognizance of the new advances in rock support technology starting from steel rib supports to the latest supporting techniques like rock bolts and steel fibre reinforced shotcrete (SFERS).

1.2 Philosophy of Classification System

In any quantitative classification system, minimum rating is assigned to the poorest rock mass and the maximum rating to the excellent rock mass. Thus, every parameter of a classification plays a more dominant role as overall rating decreases. Obviously, many classifications are accurate in both excellent and poor rock conditions. Reliability may decrease for medium rock conditions. It must be admitted that no single classification will be valid for assessment of all the rock parameters. Experience, therefore, forms the basis to select a classification for estimating a rock parameter. The objective should be to classify the undisturbed rock mass beyond excavated faces. Precaution should be taken to avoid the double-accounting of joint parameters in the classification and the analysis. Joints should not be considered in the classification if these are accounted for in the analysis.

There is need to account for fuzzy variation of rock parameters approximately after giving allowance for uncertainty. Thus, it is better to assign a range of ratings for each parameter. Experience shows that there is a wide variation in the quantitative classifications at a location. Design experience suggests that average of rock mass ratings (RMR, GSI, RMI, etc.) be considered in the design of support systems. In the case of rock mass quality (Q), a geometric mean of the minimum and the maximum values be considered in the design.

A rigorous classification system may become more reliable if uncertain parameters are dropped and considered indirectly. An easy system's approach (Hudson, 1992) is very interesting and tries to give a sequence of dominant parameters at a site (see Chapter 26).

Hoek and Brown (1997) have realized that a classification system must be non-linear to classify poor rock masses realistically. In other words, the reduction in strength parameters with classification should be non-linear unlike RMR in which strength parameters decrease linearly with decreasing RMR. (Infact, Mehrotra, 1992 has found that strength parameters decrease non-linearly with RMR for dry rock masses). More research is needed on non-linear correlations for rock parameters.

It may be highlighted here that a sound engineering judgement evolves out of a very hard work for a long time in the field.

1.3 Management of Uncertainties

Empirical, numerical or analytical and observational approaches are the various tools for engineering designs. The empirical approach, based on rock mass classifications, is the most popular probably because of its basic purpose of simplicity and ability to managing uncertainties. The geological and geotechnical uncertainties can be tackled effectively using proper classifications. Moreover, the designers can take on-the-spot decisions on supporting measures etc., if there is sudden change in the geology. Analytical approach, on the other hand, is based on uncertain assumptions and moreover obtaining the correct values of input parameters is time-consuming and expansive. The observational approach, as the name indicates, is based on monitoring the efficiency of the support system.

Philosophy of quantitative classifications

The classifications are likely to be invalid where damage due to blasting and weathering is of serious nature, e. g., in cold regions and under oceans, etc. Further, rock has EGO (Extraordinary Geological Occurrence) problems which should be solved under guidance of national and international experts.

According to Fairhurst (1993), designers should develop design solutions and design strategies that are robust, i.e., able to perform well and adequate even in unknown geological conditions. For example, shotcreted and reinforced rock arch is a robust design strategy. Historically, the Norwegian Method of Tunnelling (NMT) has evolved a successful strategy out of 25 years of experience which may be adopted in tunnel supporting in widely different rock conditions.

1.4 Present Day Practice

The present practice is a combination of all these approaches. This is basically a "Design as You Go" approach. Experience led to the following strategy of refinement in the design of support systems.

- (i) In feasibility studies, empirical correlations may be used for estimating rock parameters.
- (ii) At the design stage, insitu tests should be conducted for major projects to determine the actual rock parameters. It is suggested that insitu triaxial tests (with σ_1 , σ_2 and σ_3 applied on sides of the cube of rock mass) should be conducted extensively, because σ_2 is found to effect both strength and deformation modulus of rock masses. This is the motivation for research and its presentation here is likely to prove the urgent need for the insitu triaxial tests.
- (iii) At the initial construction stage, instrumentation should be carried out in the drifts, caverns, intersections and other important locations with the object of getting field data on displacements both on the supported excavated surfaces and within the rock mass. Instrumentation is also essential for monitoring of construction quality. Experience has confirmed that instrumentation in a complex geological environment is the key to success for safe and steady tunnelling rate. This data should be utilized in the computer modelling for back analysis of both the model and its parameters (Sakurai, 1993).
- (iv) At the construction stage, forward analysis of rock structures should be carried out using above back analyzed model and the parameters of rock masses. Repeated cycles of back analysis and forward analysis (BAFA) may eliminate many inherent uncertainties in geological mapping and knowledge of engineering behaviour of rock masses. Where broken/plastic zones are predicted, the borehole extensometers should reveal a higher rate of displacements in the broken zone than those in the elastic zone. The predicted displacements are very sensitive to the assumed model, parameters of rock masses and discontinuities; and insitu stresses, etc.

- (v) However, the aim of computer modeling should be to design site specific support systems and not just analysis of the strains and stresses in the idealized geological environment. In case of a non-homogeneous and complex geological environment, which is difficult to predict, slightly conservative values of rock parameters may be assumed for the purpose of designing site specific remedial measures (lines of defences) and for accounting inherent uncertainties in geological and geotechnical investigations.
- (vi) Be prepared for the worst and hope for the best.

1.5 Scope of the Book

Scope of the book is to present an integrated system of classifications and their applications for slopes, foundations and tunnels in light of the field research conducted in India and Europe in last two and a half decades.

It is a specialised book on rock mass classifications and is written for the civil engineers and geologists who have basic knowledge of the classifications. For the analysis and design of rock slopes, readers may consult some other book. This book does not deal with the slope analysis and design.

This book is written to help civil engineers and geologists working in civil engineering projects such as hydroelectric projects, foundations, tunnels, caverns and rapid landslide hazard zonation.

A few engineers are used to the assumption that a rock mass is homogeneous and isotropic. This may not always be correct. Infact, shear zones are encountered frequently. Therefore, due attention has been given to their proper treatment as discussed in the next chapter.

References

- Fairhurst, C. (1993). Analysis and Design in Rock Mechanics - The General context, *Comprehensive Rock Engineering*, Pergamon, **Vol. 3, Chap. 1**, pp. 1 - 29.
- Hoek, E. and Brown, E. T. (1997). Practical Estimation of Rock Mass Strength, *Int. Jr. Rock Mech. and Min. Sci.*, Pergamon, **Vol. 34, No. 8**, pp. 1165-1186.
- Mehrotra, V. K. (1993). Estimation of Engineering Properties of Rock Mass, *Ph. D Thesis, University of Roorkee*, India, p. 267.
- Hudson, J. A. (1992). *Rock Engineering Systems - Theory and Practice*, Ellis Horwood Ltd. , U.K., p. 185.
- Sakurai, S. (1993). Back Analysis in Rock Engineering, *ISRM News Journal*, **Vol. 2, No. 2**, pp. 4 -16.

CHAPTER - 2

SHEAR ZONE TREATMENT IN TUNNELS AND FOUNDATIONS

"Nature is different everywhere, and she does not follow the text books"
Stini

2.1 Shear Zone

A shear zone is a zone in which shearing has occurred so that the rock mass is crushed and brecciated. Shear zone is an outcome of a fault where the displacement is not confined to a single fracture, but is distributed through a fault zone. The shear zones vary in thickness from a fraction of meters to hundreds of meters. Depending upon the thickness, the shear zone has variable effect on the stability of underground openings and foundations. Higher the thickness of a shear zone, more will be the chances of its instability. Clayey gouge in a shear zones is generally highly over-consolidated and show high cohesion. Similarly, weak zones are also cause of instability.

2.2 Treatment for Tunnels

Rock mass classifications consider only the homogeneous units and so down-grading the rock quality adjacent to shear zones may be difficult. It is envisaged that the rock mass affected by a shear zone is much larger than the shear zone itself. Hence, this rock mass must be down-graded to the quality of the shear zone so that a heavier support system than a regular one can be installed. A method has been developed at NGI (Norwegian Geotechnical Institute) for assessing support requirements using the Q-system (Chapter 8) for rock masses affected by shear zones (Grimstad and Barton, 1993). In this method, weak zones and the surrounding rock mass are allocated their respective Q-values from which a mean Q-value can be determined, taking into consideration the width of the weak zone. The following formula (Eqn. 2.1) may be employed in calculating the weighted mean Q-value from the two Q - values (Bhasin et al., 1995).

$$\log Q_m = \frac{b \cdot \log Q_{wz} + \log Q_{sr}}{b + 1} \quad (2.1)$$

where,

- Q_m = mean value of rock mass quality Q for deciding the support,
- Q_{wz} = Q value of the weak zone,
- Q_{sr} = Q value of the surrounding rock, and
- b = width of the weak zone in metre.

The strike direction (θ) and thickness of weak zone (b) in relation to the tunnel axis is important for the stability of the tunnel and therefore the following correction factors have been suggested for the value of b in the above Eqn. 2.1.

if $\theta = 90^\circ - 45^\circ$ to the tunnel axis then use $1b$

if $\theta = 45^\circ - 20^\circ$ then use $2b$ in place of b

if $\theta = 10^\circ - 20^\circ$ then use $3b$ in place of b

if $\theta < 10^\circ$ then use $4b$ in place of b

Equation 2.1 may also be used for estimating the weighted average value of joint roughness number J_{rm} after replacing $\log Q$ by J_r appropriately. Similarly, the weighted mean of Joint alteration number J_{am} may also be found out.

Further, multiplying Eqn. 2.1 by 25 in the numerator and replacing $25 \log Q$ by E (see Eqn. 8.13), one gets the average value of modulus of deformation E_m as follows:

$$E_m = \frac{b \cdot E_{wz} + E_{sr}}{b + 1} \quad (2.2)$$

where,

E_{wz} = modulus of deformation of the weak zone or the shear zone, and

E_{sr} = modulus of deformation of the surrounding rock mass.

A 3D finite element analysis of underground powerhouse of Sardar Sarovar Hydroelectric Project shows that the maximum deflections of wall are increased near the shear zone ($b = 2$ m) by a factor of E_{sr}/E_m . Further, the predicted support pressure on shotcrete near the shear zone are increased to about $2 \cdot Q_m^{1/3}/J_{rm}$ whereas the support pressure in the surrounding rock away from shear zone are approximately $2 \cdot Q_{sr}^{1/3}/J_{rsr}$; in which J_{rsr} is joint roughness number of the surrounding rock mass (Samadhiya, 1998). These computations are quite encouraging.

Thus, E_m , Q_m and J_{rm} may also be used to design support system for shear zones or weak zone by a semi-empirical method which is discussed in Chapter 12.

Hence, if the surrounding rock mass near a shear zones is downgraded with the use of the above equations, a heavier support should be chosen for the whole area instead of the weak zone alone.

Figure 2.1 shows a typical treatment method for shear zones (Lang, 1971). First the shear zone is excavated upto some depth. It is then reinforced with inclined rock bolts and finally shotcrete (preferably steel fibre reinforced shotcrete) should be sparyed ensuring its proper thickness in weak zones. This methodology is urgently needed if NATM or NTM (Norwegian Tunnelling Method) is to be used in the tunnels of the Himalayan region, as seams/ shear

Shear zone treatment in tunnels and foundations

zones/ faults/ thrusts/ thin intra-thrust zones are frequently found along tunnels and caverns in the Himalayas.

In case of a thick shear zone ($b \gg 2\text{m}$) with sandy gouge, umbrella grouting or rock bolting is used to enhance the strength of roof and walls in advance of tunnelling. The excavation is made manually. Steel ribs are placed closely and shotcreted until the shear zone is crossed. Each round of advance should be limited to 0.5m or even smaller depending upon the stand-up time of the material and fully supported before starting another round.

2.3 Treatment for Dam Foundations

Treatment of a shear zone in a concrete dam foundation consists of dental treatment as shown in Figure 2.2. The vertical depth 'd' of excavation of weak zone and back-filling by concreting is recommended by U.S.B.R. as follows,

$$\begin{aligned} d &= 0.00656 b H + 1.53 \quad (\text{m}) \quad \text{for } H < 46\text{m} \\ &= 0.3 b + 1.52 \quad (\text{m}) \quad \text{for } H \geq 46\text{m} \\ &> 0.1 H \quad \text{in seams with clayey gouge} \end{aligned} \quad (2.3)$$

where,

- H = height of dam above general foundation level in metres,
- b = width of weak zone in metres, and
- d = depth of excavation of weak zone below surface adjoining the sound rock in metres.

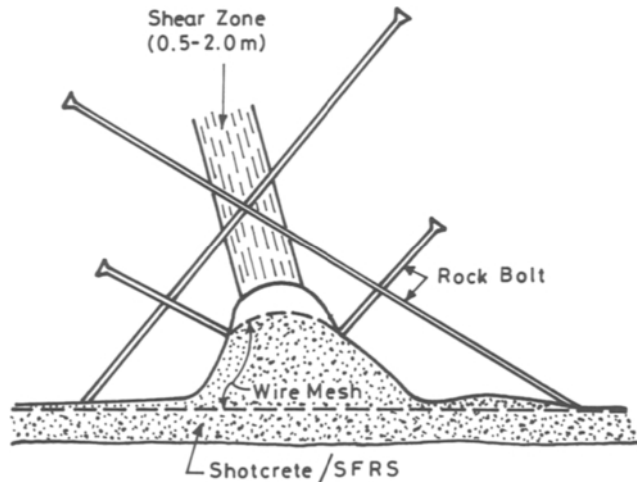

Figure 2.1: Shear zone treatment in an underground opening (Lang, 1971)

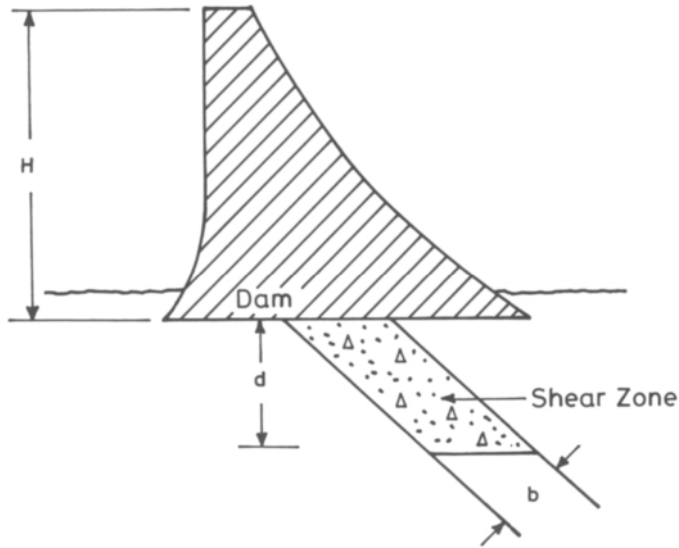

Figure 2.2 : Shear zone treatment below dam foundations

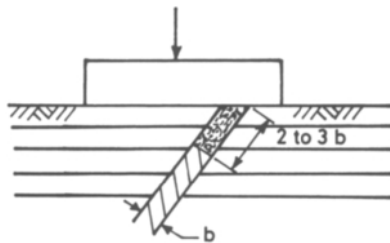

Figure 2.3: Weak seams under foundation less than 20 per cent area

The infilling and crushed weathered rock is oozed out at very high pressure and then back-filled by rich concrete. No blasting is used to avoid damage to the rock mass.

The treatment of shear zones, joints, solution cavities in limestone, etc. is essential for long life of building foundations. The strategy of their treatment should be the same as adopted for dam foundations and shown in Figures 2.3 to 2.5 as per Indian Standard IS: 13063.

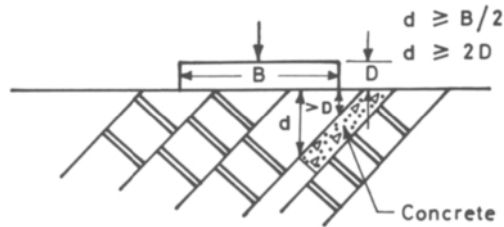

Figure 2.4: Foundation on steeply dipping clay seam

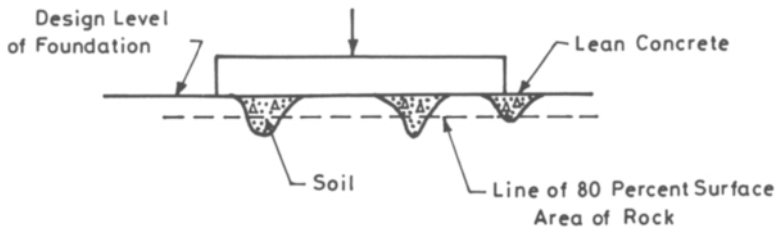

Figure 2.5: Foundation on undulating rock surface

Undulating rock profiles give major problems in construction of footings, well foundations and piles. However, massive rocks do not pose problems of instability. Their behaviour is similar to that of the rock material (intact rock).

References

- Bhasin, R., Singh, R. B., Dhawan A. K. and Sharma, V. M. (1995). Geotechnical Evaluation and a Review of Remedial Measures in Limiting Deformations in Distressed Zones in a Powerhouse Cavern, *Conf. on Design and construction of underground structures*. New Delhi, India, pp. 145-152.
- Grimstad, E. and Barton, N. (1993). Updating of the Q-system for NMT, *Proc. Int. Symposium on Sprayed Concrete - Modern use of wet mix sprayed concrete for underground support*, Fagernes, Norwegian Concrete Association, Oslo.
- I.S. 13063: 1991 on Structural Safety of Buildings on Shallow Foundations on Rock - Code of Practice, *Bureau of Indian Standards*, New Delhi, India, p. 15.
- Lang, T. A. (1971). Theory and Practice of Rock Bolting, *AIME, Trans.* **220**.
- Samadhiya, N. K. (1998). Influence of Shear Zone on Stability of Cavern. *Ph. D. Thesis, Dept. of Civil Engineering, University of Roorkee*, India, p. 334.
- U.S.B.R. (1976). Design of Gravity Dams, pp. 97-105.

CHAPTER - 3

ROCK MATERIAL

3.1 Rock Material

The term "Rock Material" refers to the intact rock within the framework of discontinuities. In other words, this is the smallest element of rock block not cut by any fracture. There are always some micro fractures in the rock material but these should not be treated as fractures. 'Rock material' differs from 'rock mass' which refers to insitu rock together with its discontinuities and weathering profile. Rock material has the following characteristics:

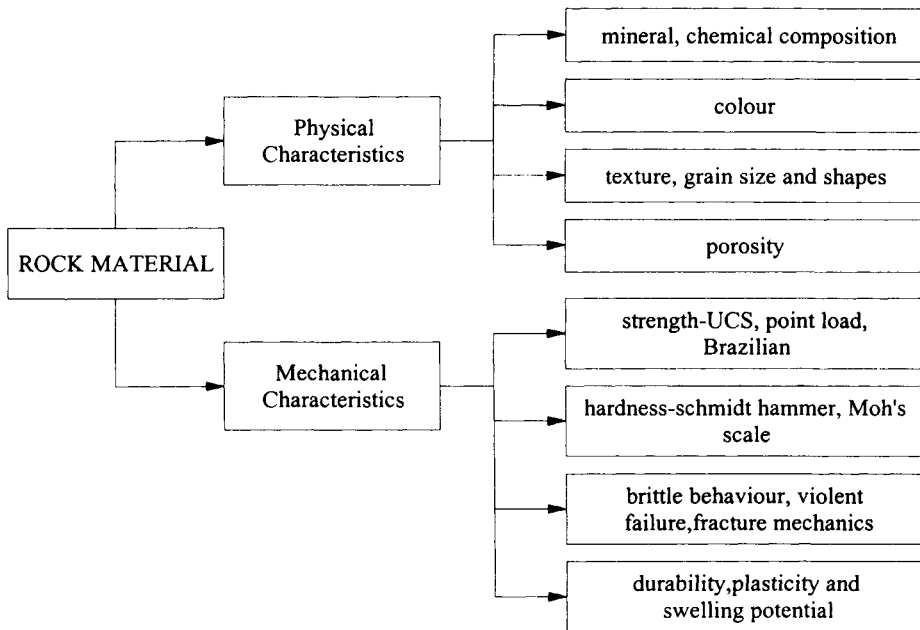

3.2 Homogeneity and Inhomogeneity

Bray (1967) demonstrated that if the rock contains 10 or more sets of discontinuities (joints), then its behaviour can be approximated to the behaviour of a homogeneous and isotropic mass with only 5 per cent error due to assumed homogeneity and isotropy condition. Also, if a rock is massive and contains very little discontinuity, it could be idealized to behave as a

homogeneous medium. Hoek and Brown (1980) showed that homogeneity is a characteristic dependent on the sample size. If the sample size is considerably reduced, the most heterogeneous rock will become a homogeneous rock (Figure 3.1). In Figure 3.1 's' is a constant which depends on rock mass characteristics as discussed in Chapter 25. Deere et al. (1969) suggested that if the ratio between fracture spacing and opening size is equal to or less than 1/100, the rock should be considered discontinuous and beyond this range it should be considered a continuum and possibly anisotropic.

An inhomogeneous rock is more predictable than a homogeneous rock as the weakest rock will start giving distress signals much before final collapse of the rock-structure.

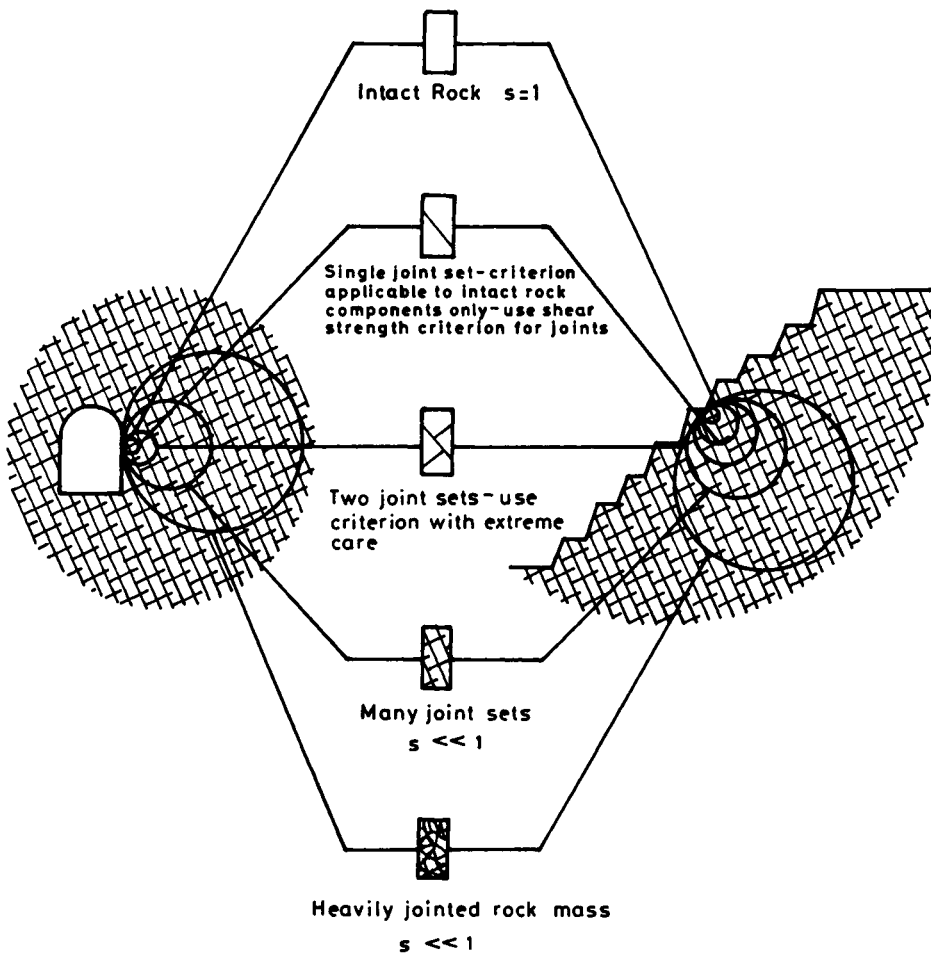

Figure 3.1: Rock mass conditions under the Hoek-Brown failure criterion (Hoek, 1994)

3.3 Classification of Rock Material

Ancient Shilpsastra in India classified rocks on the basis of colour, sound and heaviness. Stapledon (in John, 1971) and ISRM proposed classification of rock material based on uniaxial compressive strength as shown in Table 3.1. It is evident that a rock material may show a large scatter in strength, say of the order of 10 times. Hence the need for such a classification system which is based on strength and not mineral contents.

TABLE 3.1
CLASSIFICATION OF ROCK MATERIAL BASED ON UNCONFINED COMPRESSIVE STRENGTH
(STAPLEDON AND ISRM)

| Term for Uniaxial Compressive Strength | Symbol | Strength (MPa) | Ranges for some Common Rock Materials | | | | |
|--|--------|----------------|--|------------------|----------------------|-------|----------|
| | | | Granite, Basalt, Gneiss, Quartzite, Marble | Schist Sandstone | Limestone, Siltstone | Slate | Concrete |
| Extremely Weak | EW | 0.25 - 1 | | ** | ** | | |
| Very weak | VW | 1 - 5 | | ** | ** | ** | ** |
| Weak | W | 5 - 25 | | ** | ** | ** | ** |
| Medium Strong | MS | 25 - 50 | ** | | ** | ** | |
| Strong | S | 50 - 100 | ** | | | | |
| Very Strong | VS | 100 - 250 | ** | | | | |
| Extremely Strong | ES | >250 | ** | | | | |

The uniaxial compressive strength (UCS) can be easily predicted from point load strength index tests on rock cores and rock lumps right at the drilling site because ends of rock specimens need not be cut and lapped. UCS is also found from Schmidt's rebound hammer (Figure 14.4).

There are frequent legal disputes on soil-rock boundary. International Standard Organisation (ISO) classifies a geological material having UCS less than 0.6 MPa as soil.

Deere and Miller (John, 1971) have suggested another useful classification system based on modulus ratio, which is defined as the ratio between elastic modulus and uniaxial compressive strength. Physically, modulus ratio indicates inverse of the axial strain at failure. Thus, brittle materials have high modulus ratio and plastic materials exhibit low modulus ratio.

3.4 Class I and II Rocks

Rock material has been divided into two classes according to their post-peak stress-strain curve (Wawersik, 1968).

Class I: Failure propagation is stable in the sense that each increment of deformation beyond the point of maximum load carrying capacity requires an increment of work to be done on the rock, whereas

Class II: Rocks are unstable or self - sustaining; elastic energy must be extracted from the material to control fracture.

The introduction of partial confinement, as in case of short samples when end constraint become prominent, is likely to have a satisfactory effect. If end restraint becomes severe, it is possible that a Class II rock may in effect behave like a Class I material.

Wawersik (1968) conducted experiments on six rock types to demonstrate Class I and II rock types as shown in Figure 3.2. Typical S shape stress-strain curves may be obtained for rocks due to presence of micro-fractures. Further, post-peak curve for class II rocks shows reduction of strain after failure. It should be mentioned that the lateral strain increases rapidly after peak stress in class II rocks. Brittle rocks, therefore, may be kept in class II category.

Thus, a deep tunnel within dry massive hard rocks of Class II and laminated rocks may fail by rock bursts due to uncontrolled fracturing where tangential stress exceeds the strength of the rock material. Hence the need for testing rock material in Servo controlled closed Loop Testing Machines to get the post peak curve.

3.5 Uniaxial Compression

Rock failure in uniaxial compression occurs in two modes:

- (i) Local (axial) splitting or cleavage failure parallel to the applied stress, and
- (ii) Shear failure.

Local cleavage fracture characterizes failure initiation at 50 percent to 95 percent of the compressive strength and is continuous throughout the entire loading history. Axial cleavage fracture is a local stress relieving phenomenon which depends on the strength anisotropy and brittleness of the crystalline aggregates as well as on the grain size of the rock. Local axial splitting is virtually absent in fine grained materials at stress levels below their compressive strength.

Shear failure manifests itself in the development of boundary faults followed by interior fractures which are oriented at 12° and 18° and at approximately 30° with respect to sample axis. In fine grained materials in which the inhomogeneity of the stress distribution depends only on the initial matching of the material properties at the loading platen interfaces, boundary and interior faults are likely to develop simultaneously and appear to have the same orientation for any one rock type within the accuracy of the measurements on the remnant pieces of collapsed specimens (basalts, etc.).

Local axial fracturing governs the maximum load-carrying ability of coarse grained, locally inhomogeneous Class I and II rock types. Thus, in the case of the coarse grained rocks the

ultimate macroscopic failure mode of fully collapsed samples in uniform uniaxial compression cannot be related to peak stress. In the case of the fine grained, locally homogeneous rock types, which most likely are of Class II, the peak stress is probably characterized by the development of shear fractures, i.e., of continuous failure planes. Hence, in controlled fracture experiments on very fine grained rocks, the final appearance of a collapsed rock specimen can probably be correlated with its compressive strength. However, if

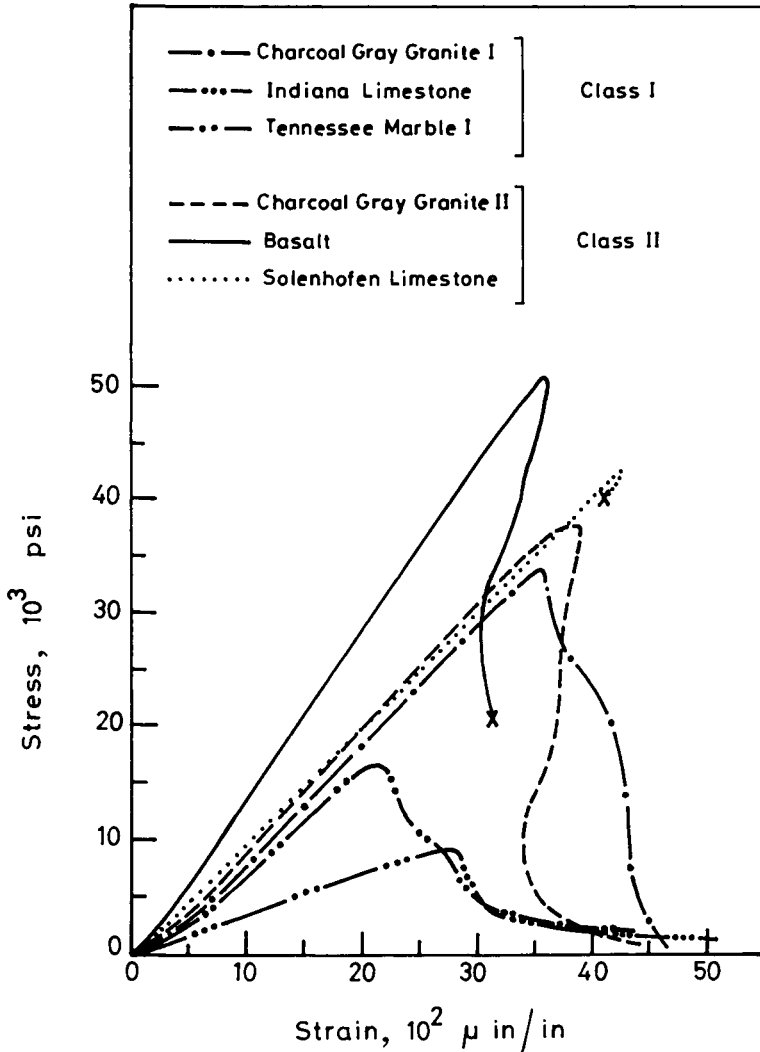

Figure 3.2: Stress-strain curve for six representative rocks in uniaxial compression (Wawersik, 1968)

rock fracture is uncontrolled, then the effects of stress waves produced by the dynamic release of energy may over-ride the quasi-elastic failure phenomenon to such an extent that the latter may no longer be recognisable.

The extent of the development of the two basic failure modes, local axial splitting and slip or shear failure, determines the shape of the stress - strain curve for all rocks subjected to uni-directional or triaxial loading. Partially failed rocks still exhibit elastic properties. However, the sample stiffness decreases steadily with increasing deformation and loss of strength.

Macroscopic cleavage failure, in the sense that laboratory samples would split axially into two or more segments, was never observed in the experiments on Class I and II rocks. Moreover, an approximate theoretical analysis of the "sliding surface" model which was proposed by Fairhurst and Cook (1966) has revealed qualitatively that unstable axial cleavage fracture is an unlikely failure mode of rocks in uniaxial compression.

3.6 Stability in Water

In hydroelectric projects, rocks are charged with water. The potential for disintegration of rock material in water can be determined by immersing rock pieces in water upto one week. Its behaviour should be described using the terms of Table 3.2 (ISO - 1997).

TABLE 3.2
ROCK MATERIAL STABILITY IN WATER (ISO - 1997)

| S. No. | Stability Condition | Rock Behaviour in Water |
|--------|---------------------|-------------------------|
| 1 | Stable | unaffected |
| 2 | Fairly Stable | breaks down partly |
| 3 | Unstable | breaks down completely |

It is interesting to observe that ultrasonic pulse velocity in a saturated rock is higher than that in a dry rock as it is easier for pulse to travel through water than in air voids. However, the uniaxial compressive strength and modulus of elasticity are reduced significantly after saturation, particularly in rocks with water sensitive minerals. On the other hand, the post-peak stress-strain curve becomes flatter in the case of undrained UCS tests on saturated samples because increasing fracture porosity after failure creates negative pore water pressure.

3.7 Classification on the Basis of Slake Durability Index

Based upon his tests on representative shales and clay stones for two numbers of 10 minute cycle after drying, Gamble (1971) found the slake durability index to vary over the whole range from 0 to 100%. There are no visible connections between durability and geological age, but durability increased linearly with density and inversely with natural water content. Based on his results, therefore, Gamble proposed a classification of slake durability as given

in Table 3.3. The slake durability classification is useful in the selection of rock aggregates for road, rail line, concrete and shotcrete.

TABLE 3.3
SLAKE DURABILITY CLASSIFICATION (GAMBLE, 1971)

| Group Name | % retained after one 10 minute cycle (dry weight basis) | % retained after two 10 minute cycles (dry weight basis) |
|------------------------|---|--|
| Very High durability | >99 | >98 |
| High durability | 98-99 | 95-98 |
| Medium High durability | 95-98 | 85-95 |
| Medium durability | 85-95 | 60-85 |
| Low durability | 60-85 | 30-60 |
| Very Low durability | <60 | <30 |

Rock in field is generally jointed. It was classified by core recovery in the past and latter in sixties by modified core recovery (RQD).

References

- Bray, J.W. (1967). A Study of Jointed and Fractured Rock. Part I, *Rock Mechanics and Engineering Geology*, **Vol. 5-6/2-3**, pp. 117-136.
- Decre, D.U., Peck, R. B., Monsees, J.E. and Schmidt, B. (1969). Design of Tunnel Liners and Support System. *Final Report, University of Illinois, Urbana, for office of High Speed Transportation, U.S. Department of Transportation, Contract No. 3-0152*, p. 404.
- Fairhurst, C. and Cook, N. G. W. (1966). The Phenomenon of Rock Splitting Parallel to the Direction of Maximum Compression in the Neighborhood of a surface. *Proc. 1st Cong. Int. Soc. Rock Mechanics*, Lisbon.
- Gamble, J. C. (1971). Durability - Plasticity Classification of Shales and other Argillaceous Rocks, *Ph. D. Thesis, University of Illinois, USA*, p. 159.
- Hoek, E. and Brown, E. T. (1980). *Underground Excavations in Rocks*, Institution of Mining & Metallurgy, London.
- Hoek, E. (1994). Strength of Rock and Rock Masses, *ISRM News Journal*, **Vol. 2**, No. 2, pp. 4-16.
- ISO Draft Standard on Geotechnics in Civil Engineering - Identification and Description of Rock, **ISO/DIS 14689**, 1997, p.18.
- John, M. (1971). Properties and Classification of Rocks with Reference to Tunnelling, *NMERE Council of Scientific & Industrial Research, Pretoria, South Africa, MEG 1020*.
- Wawersik, W. R. (1968). Detailed Analysis of Rock Failure in Laboratory Compression Tests, *Ph. D. Thesis, University of Minnesota, USA*, p. 165.

CHAPTER - 4

ROCK QUALITY DESIGNATION

4.1 Rock Quality Designation (RQD)

Rock quality designation RQD was introduced by D. U. Deere in 1964 as an index of assessing rock quality quantitatively. It is a more sensitive index of the core quality than the core recovery.

The RQD is a modified per cent core-recovery which incorporates only sound pieces of core that are 100 mm (4 inch.) or greater in length along the core axis,

$$\text{RQD} = \frac{\text{sum of core pieces} \geq 10 \text{ cm}}{\text{total drill run}} \cdot 100, \%$$

Following are the methods of obtaining RQD

4.2 Direct Method

For RQD determination, the International Society for Rock Mechanics (ISRM) recommends a core size of at least NX (size 54.7 mm) drilled with double-tube core barrel using a diamond bit. Artificial fractures can be identified by close fitting of cores and unstained surfaces. All the artificial fractures should be ignored while counting the core length for RQD. A slow rate of drilling will also give better RQD. The relationship between RQD and the engineering quality of the rock mass as proposed by Deere (1968) is given in Table 4.1.

TABLE 4.1
CORRELATION BETWEEN RQD AND ROCK MASS QUALITY

| S. No. | RQD (%) | Rock Quality |
|--------|---------|--------------|
| 1 | <25 | Very poor |
| 2 | 25-50 | Poor |
| 3 | 50-75 | Fair |
| 4 | 75-90 | Good |
| 5 | 90-100 | Excellent |

The correct procedure for measuring RQD is shown in Figure 4.1. RQD is perhaps the most commonly used method for characterising the degree of jointing in borehole cores, although this parameter also may implicitly include other rock mass features like weathering and 'core loss' (Bieniawski, 1989).

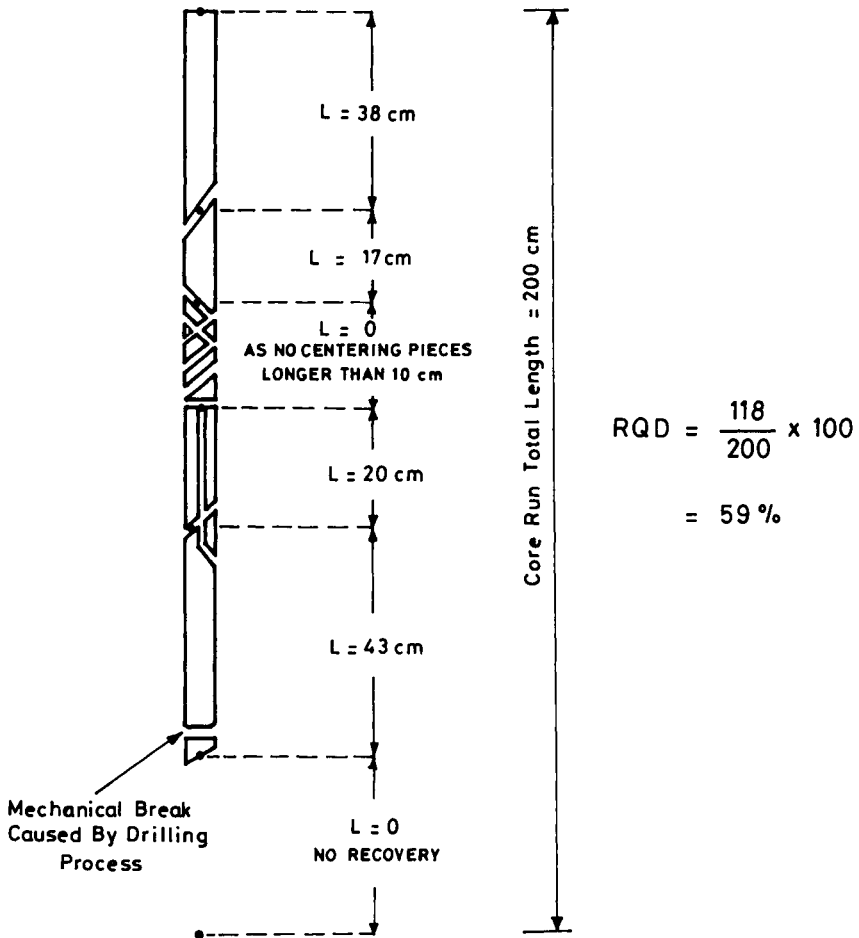

Figure 4.1: Procedure for measurement and calculation of rock quality designation RQD (Deere, 1989)

4.3 Indirect Methods

4.3.1 Seismic Method

The seismic survey method makes use of the variation of elastic properties of the strata that affect the velocity of the seismic waves travelling through them, thus providing useful information about the subsurface strata. This method has the advantages of being relatively cheap and rapid to apply and helps in studying large volume of rock masses. The following information in respect of the rock masses is obtained from these tests.

- a. Location and configuration of bed rock and geological structures in the subsurface,

Rock quality designation

- b. The effect of discontinuities in rock mass may be estimated by comparing the insitu compressional wave velocity with laboratory sonic velocity of intact drill core obtained from the same rock mass.

$$\begin{aligned} \text{RQD (\%)} &= \text{Velocity ratio} \\ &= (V_f/V_l)^2 \cdot 100 \end{aligned}$$

where V_f is insitu compressional wave velocity, and V_l is compressional wave velocity in intact rock core.

For details of a seismic method, any text book dealing this topic may be referred.

4.3.2 Volumetric Joint Count

When cores are not available, RQD may be estimated from number of joints (discontinuities) per unit volume J_v . A simple relationship which may be used to convert J_v into RQD for clay-free rock masses is (Palmstrom, 1982),

$$\text{RQD} = 115 - 3.3 J_v \quad (4.1)$$

where J_v represents the total number of joints per cubic meter or the volumetric joint count.

The volumetric joint count J_v has been described by Palmstrom (1982, 1985, 1986) and Sen and Eissa (1992). It is a measure for the number of joints within a unit volume of rock mass defined by

$$J_v = \sum_{i=1}^J \left(\frac{1}{S_i} \right) \quad (4.2)$$

where S_i is the average joint spacing in metres for the i th joint set and J is the total number of joint sets except the random joint set.

Random joints may also be considered by assuming a 'random spacing'. Experience indicates that this should be set to $S_r = 5\text{m}$ (Palmstrom, 1996). Thus, the volumetric joint count can be generally expressed as

$$J_v = \sum_{i=1}^J \left(\frac{1}{S_i} \right) + \frac{N_r}{5} \quad (4.3)$$

where N_r can easily be estimated from joint observations, as it is based on common measurements of joint spacings or frequencies. In cases where random or irregular jointing occurs, J_v can be found by counting all the joints observed in an area of known size. Table 4.2 shows the classification of J_v .

TABLE 4.2
CLASSIFICATION OF VOLUMETRIC JOINT COUNT J_v (PALMSTROM, 1982 & 1996)

| S. No. | Term for Jointing | Term for J_v | J_v |
|--------|-----------------------|-----------------|-----------|
| 1. | Massive | Extremely low | <0.3 |
| 2. | Very weakly jointed | Very low | 0.3 - 1.0 |
| 3. | Weakly jointed | Low | 1 - 3 |
| 4. | Moderately jointed | Moderately high | 3 - 10 |
| 5. | Strongly jointed | High | 10 - 30 |
| 6. | Very strongly jointed | Very high | 30 - 100 |
| 7. | Crushed | Extremely high | >100 |

Though the RQD is a simple and inexpensive index, when considered alone it is not sufficient to provide an adequate description of a rock mass because it disregards joint orientation, joint condition, type of joint filling and stress condition.

4.4 Weighted Joint Density

The weighted joint measurement method, proposed by Palmstrom (1996), is developed to achieve better information from borehole and surface observations. In principle, it is based on the measurement of the angle between each joint and the surface or the drillhole. The weighted joint density (wJd) is defined as

for measurements in rock surface

$$wJd = \frac{1}{\sqrt{A}} \sum \frac{1}{\sin \delta} = \frac{1}{\sqrt{A}} \sum f_i \quad (4.4)$$

for measurements along a drill core or scanline

$$wJd = \frac{1}{\sqrt{L}} \sum \frac{1}{\sin \delta} = \frac{1}{\sqrt{L}} \sum f_i \quad (4.5)$$

where δ is the intersection angle, i.e., the angle between the observation plane or drillhole and the individual joint; A is the size of the observed area in metres²; L is the length of the measured section along the core or scanline (Figure 4.2) and f_i is a rating factor.

To solve the problem of small intersection angles and to simplify the observations, the angles have been divided into intervals for which a rating of f_i has been selected as shown in Table 4.3. The selection of intervals and the rating of f_i have been determined from a simulation.

To make the approach clear, examples are given below for both surface and drillhole measurements.

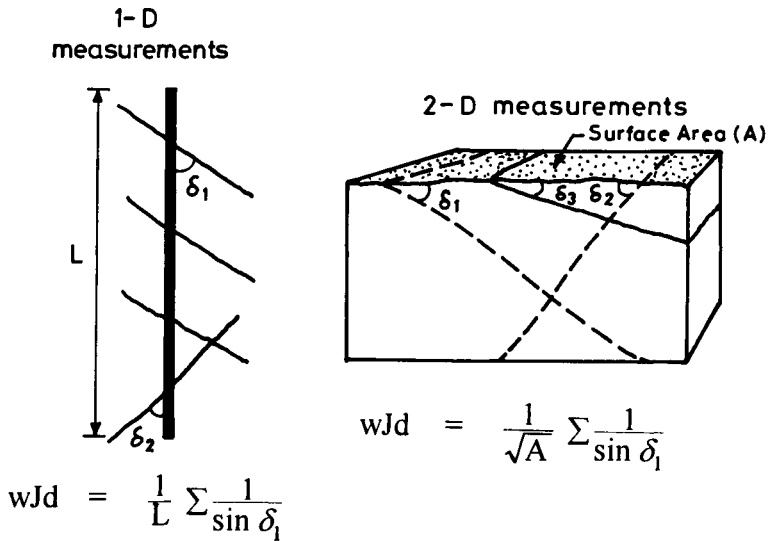

Figure 4.2: The intersection between joints and a drill core hole (left) and between joints and a surface (right) (Palmstrom, 1996)

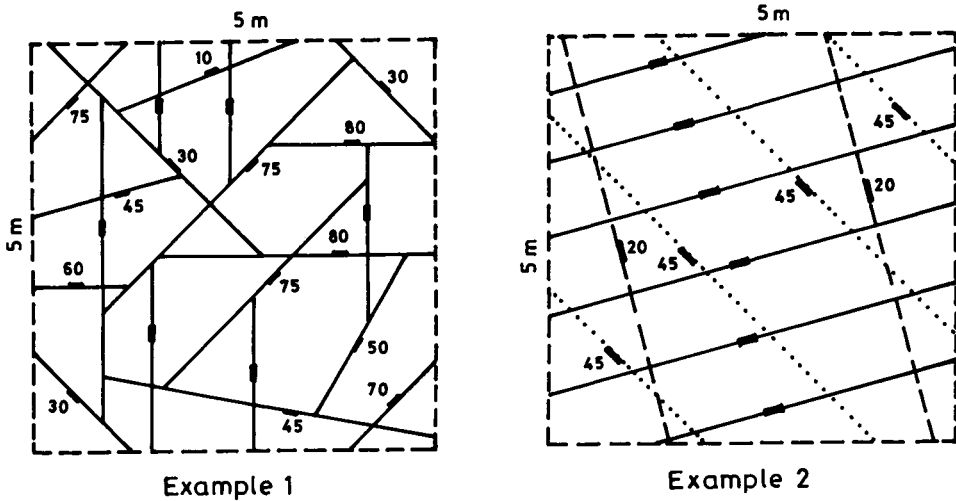

Figure 4.3: Two examples of jointing on a surface (Palmstrom, 1996)

4.4.1 Surface Measurement

Two examples of jointing seen on a surface are shown in Figure 4.3. The observation area in both the examples is 25 m², and the results from the observations are given in Table 4.4. In the

second example all the joints belong to joint sets and there is no random joint. Thus, it is possible to calculate the volumetric joint count ($J_v = 3.05$) from the joint spacings of 0.85 m, 1.0 m and 1.1 m. As seen, the weighted joint density measurement gives here values which are somewhat higher than the known value for the volumetric joint count (Palmstrom, 1996).

TABLE 4.3
ANGLE INTERVALS AND RATING OF THE FACTOR f_i (PALMSTROM, 1996)

| Angle (δ) Between Joint and Surface or Borehole | Rating of the Factor f_i |
|--|----------------------------|
| $> 60^\circ$ | 1 |
| 31 - 60° | 1.5 |
| 16 - 30° | 3.5 |
| $< 16^\circ$ | 6 |

TABLE 4.4
CALCULATION OF WEIGHTED JOINT DENSITY FROM ANALYSIS OF JOINTING SHOWN FOR THE SURFACES IN FIGURE 4.3 (PALMSTROM, 1996)

| Location | Area A | Number of Joints (n) within Each Interval | | | | Total Number of Joints from Figure 4.3 | Number of Weighted Joints $N_w = \sum n \times f_i$ | wJd = $(1/\sqrt{A}) N_w$ | J_v |
|-------------------|----------------|---|----------------|----------------|-------------|---|--|--------------------------|-------|
| | m ² | $>60^\circ$ | 31- 60° | 16- 30° | $<16^\circ$ | | | | |
| Example 1 | 25 | 12 | 4 | 3 | 1 | 20 | 34.5 | 6.9 | |
| Example 2 | 25 | 6 | 4 | 2 | 0 | 12 | 19 | 3.8 | 3.05 |
| Rating of $f_i =$ | | 1 | 1.5 | 3.5 | 6 | | | | |

TABLE 4.5
THE CALCULATION OF THE WEIGHTED JOINT DENSITY FROM REGISTRATION OF JOINTING IN THE BOREHOLE IN FIGURE 4.4 (PALMSTROM, 1996)

| Depth | Length L | Number of Joints (n) within Each Interval | | | | Total Number of Joints from Figure 4.4 | Number of Weighted Joints $N_w = \sum n \times f_i$ | wJd = $(1/L) N_w$ |
|-------------------|----------|---|----------------|----------------|-------------|---|--|-------------------|
| | | $>60^\circ$ | 31- 60° | 16- 30° | $<16^\circ$ | | | |
| m | m | | | | | | | |
| 50 - 52.17 | 2.17 | 11 | 6 | 2 | 1 | 20 | 33 | 15 |
| 52.17 - 53.15 | 0.98 | 9 | 3 | 2 | 0 | 14 | 20.5 | 20.9 |
| 53.15 - 55.0 | 1.85 | 5 | 0 | 1 | 0 | 6 | 8.5 | 4.6 |
| Rating of $f_i =$ | | 1 | 1.5 | 3.5 | 6 | | | |

4.4.2 Drillhole Measurements

An example from core logging is shown in Figure 4.4. The 5m long part of the core has been divided into the following 3 sections with similar density of joints: 50.0 - 52.17m, 52.17 -

Rock quality designation

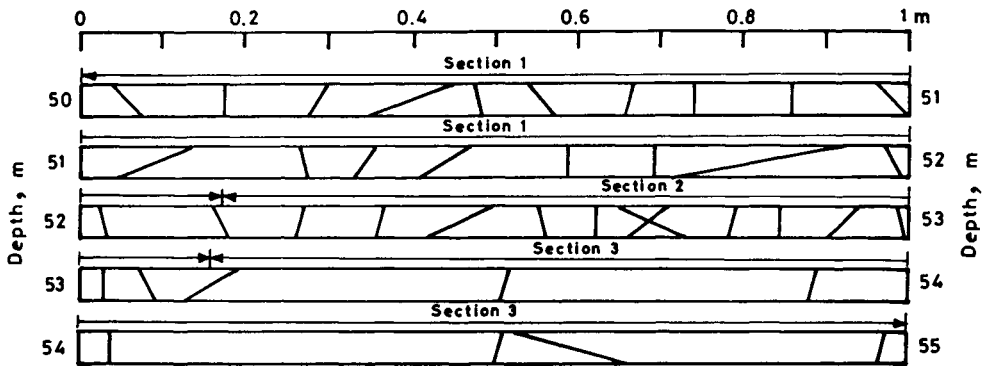

Figure 4.4: Example of jointing along part of a borehole (Palmstrom, 1996)

53.15m and 53.15 - 55.0m. For each section the number of joints within each angle interval has been counted and the results are shown in Table 4.5.

The evaluation of weighted joint density requires small additional effort over currently adopted logging practices. The only additional work is to determine which angle interval the intersection between the observation plane (or drillhole) and each joint belongs. The angles chosen for the intervals between the joint and the drillhole should be familiar to most people and this should make the observations for wJd quick. The use of only four intervals makes the registration simple and easy. In time to come, wJd may proved a useful parameter to measure the joint density accurately.

Cording and Deere (1972) attempted to relate the RQD index to Terzaghi's rock load factors. They found that Terzaghi's rock load theory should be limited to tunnels supported by steel sets, as it does not apply to openings supported by rock bolts. Next chapter deals with Terzaghi's rock load theory.

References

- Bieniawski, Z. T. (1989). *Engineering Rock Mass Classifications*. John Wiley. 251 p.
- Cecil, O. S. (1970). Correlation of Rockbolt - Shotcrete Support and Rock Quality Parameters in Scandinavian Tunnels, *Ph. D. Thesis, University of Illinois*, Urbana, 1970, 414 p.
- Cording, E. J. and Deere, D.U. (1972). Rock Tunnel Support and Field Measurements, *Proc. Rapid Excavation Tunnelling Conference, AIME*, New York, pp. 601-622.
- Deere, D. U. (1968). *Geological Considerations, Rock Mechanics in Engineering Practice*, ed. R. G. Stagg and D. C. Zienkiewicz, Wiley, New York, pp. 1-20.
- Deere, D. U. (1989). Rock Quality Designation (RQD) after Twenty Years, U. S. Army Corps of Engineers Contract Report GL-89-1, waterways Experiment Station, Vicksburg, MS. 67 pp.

Rock Mass Classification: A Practical Approach in Civil Engineering

- Palmstrom, A. (1982). The Volumetric Joint Count - A Useful and Simple Measure of the Degree of Jointing, *IVth Int. Congress IAEG*, New Delhi, pp. V221 - V228.
- Palmstrom, A. (1985). Application of the Volumetric Joint Count as a Measure of Rock Mass Jointing, *Proc. Int. Symp. on Fundamentals of Rock Joints, Bjorkliden, Sweden*, pp. 103-110.
- Palmstrom, A. (1986). A General Practical Method for Identification of Rock Masses to be Applied in Evaluation of Rock Mass Stability Conditions and TBM Boring Progress. *Proc. Conf. on Fjellsprengningsteknikk, Bergmekanikk, Geoteknikk*, Oslo, Norway, pp. 31.1-31.31.
- Palmstrom, A. (1996). RMi - A System for Characterising Rock Mass Strength for Use in Rock Engineering, *Jr. of Rock Mech. and Tunnelling Tech.*, India, **Vol. 1, No. 2**, pp. 69-108.
- Sen, Z. and Essa, E. A. (1992). Rock Quality Charts for Log-Normally Distributed Block Sizes, *Int. J. Rock Mech. Min. Sci. & Geomech. Abstr.*, Pergamon, **Vol. 29, No. 1**, pp. 1-12.

CHAPTER - 5

TERZAGHI'S ROCK LOAD THEORY

"The geotechnical engineer should apply theory and experimentation but temper them by putting them into the context of the uncertainty of nature. Judgement enters through engineering geology"

Karl Terzaghi

5.1 Introduction

This was probably the first successful attempt of classifying the rock masses for the engineering purposes. Terzaghi (1946) proposed that the rock load factor H_p is the height of loosening zone over tunnel roof which is likely to load the steel arches. These rock load factors were estimated by Terzaghi from 5.5m wide steel-arch supported rail road tunnels in the Alps during late twenties. In these investigations wooden blocks of known strengths were used for blocking the steel arches to the surrounding rock masses. Rock loads were estimated from the known strength of the failed wooden blocks. Terzaghi used these observations to back analyze rock loads acting on the supports. Subsequently, he conducted 'Trap-door' experiments on sands and found that the height of loosened arch above the roof increased directly with the opening width in the sand.

5.2 Rock Classes

Terzaghi (1946) considered the structural discontinuities of the rock masses and classified them qualitatively into nine categories, viz., (i) hard and intact, (ii) hard, stratified and schistose, (iii) massive to moderately jointed, (iv) moderately blocky and seamy, (v) very blocky and seamy, (vi) completely crushed but chemically intact, (vii) squeezing rock at moderate depth, (viii) squeezing rock at great depth and (ix) swelling rock, as described in Table 5.1.

Extensive experience from tunnels in lower Himalayas has shown that the term squeezing rock is really squeezing ground condition. Because a jointed and weak rock mass fails at high stress and squeezes into tunnels.

5.3 Rock Load Factor

Terzaghi (1946) combined the results of his trap door experiments and the estimated rock loads from Alpine tunnels to compute rock load factors H_p in terms of tunnel width B and

tunnel height H_t of the loosened rock mass above the tunnel crown (Figure 5.1) which loads the steel arches. Such rock load factors for all the nine rock classes are listed in Table 5.2.

TABLE 5.1
DEFINITIONS OF ROCK CLASSES OF TERZAGHI'S ROCK LOAD THEORY (SINHA, 1989)

| Rock Class | Type of Rock | Definition |
|------------|--|--|
| I. | Hard & intact | The rock is unweathered. It contains neither joints nor hair cracks. If fractured, it breaks across intact rock. After excavation the rock may have some popping and spalling failures from roof. At high stresses spontaneous and violent spalling of rock slabs may occur from sides or roof. The unconfined compressive strength is equal to or more than 100 MPa |
| II. | Hard stratified and schistose | The rock is hard and layered. The layers are usually widely separated. The rock may or may not have planes of weakness. In such rock, spalling is quite common. |
| III. | Massive moderately jointed | A jointed rock. The joints are widely spaced. The joints may or may not be cemented. It may also contain hair cracks but the huge blocks between the joints are intimately interlocked so that vertical walls do not require lateral support. Spalling may occur. |
| IV. | Moderately blocky and seamy | Joints are less spaced. Blocks are about 1m in size. The rock may or may not be hard. The joints may or may not be healed but the interlocking is so intimate that no side pressure is exerted or expected. |
| V. | Very blocky and seamy | Closely spaced joints. Block size is less than 1m. It consists of almost chemically intact rock fragments which are entirely separated from each other and imperfectly interlocked. Some side pressure of low magnitude is expected. Vertical walls may require supports. |
| VI. | Completely crushed but chemically intact | Comprises chemically intact rock having the character of a crusher run aggregate. There is no interlocking. Considerable side pressure is expected on tunnel supports. The block size could be few centimeters to 30 cm. |
| VII. | Squeezing rock - moderate depth | Squeezing is a mechanical process in which the rock advances into the tunnel opening without perceptible increase in volume. Moderate depth is a relative term and could be upto 150m to 1000m. |
| VIII. | Squeezing rock - great depth | The depth may be more than 150m. The maximum recommended tunnel depth is 1000m (2000m in very good rocks). |
| IX. | Swelling rock | Swelling is associated with volume change and is due to chemical change of the rock usually in presence of moisture or water. Some shales absorb moisture from air and swell. Rocks containing swelling minerals such as montmorillonite, illite, kaolinite and others can swell and exert heavy pressure on rock supports. |

Terzaghi's rock load theory

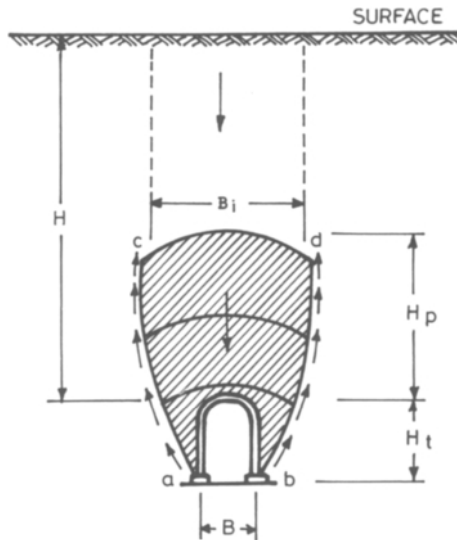

Figure 5.1: Terzaghi's (1946) rock-load concept in tunnels

For obtaining the support pressure from the rock load factor H_p , Terzaghi suggested the following equation.

$$p = H_p \cdot \gamma \cdot H \quad (5.1)$$

where p is the support pressure, γ is the unit weight of the rock mass and H is tunnel depth or thickness of overburden. A limitation of Terzaghi's theory is that it is not applicable for tunnels wider than 9m.

The roof of the tunnel is assumed to be located below the water table. If it is located permanently above the water table, the values given for classes IV to VI in Table 5.2 can be reduced by 50 percent (Rose, 1982).

Deere et al. (1970) modified Terzaghi's classification system by introducing the RQD as the lone measure of rock quality (Table 5.3). They have distinguished between blasted and machine excavated tunnels and proposed guidelines for selection of steel set, rock bolts and shotcrete supports for 6m to 12m diameter tunnels in rock. These guidelines are presented in Table 5.4.

Deere et al. (1970) also considered the rock mass as an integral part of the support system, meaning that Table 5.4 is only applicable if the rock mass is not allowed to loosen and disintegrate extensively. Deere et al. (1970) assumed that machine excavation had the beneficial effect of reducing rock loads by about 20 to 25 percent.

TABLE 5.2
ROCK LOAD IN TUNNELS WITHIN VARIOUS ROCK CLASSES (TERZAGHI, 1946)

| Rock Class | Rock Condition | Rock Load Factor H_p | Remarks |
|------------|---------------------------------|--|--|
| I. | Hard and intact | Zero | Light lining required only if spalling or popping occurs |
| II. | Hard stratified or schistose | 0-0.5B | Light support mainly for protection against spalling. Load may change erratically from point to point |
| III. | Massive moderately jointed | 0-0.25B | No side pressure |
| IV. | Moderately blocky and seamy | 0.25B-0.35 (B+H ₁) | No side pressure |
| V. | Very blocky and seamy | (0.35-1.10) (B+H ₁) | Little or no side pressure |
| VI. | Completely crushed | 1.10 (B+H ₁) | Considerable side pressure. Softening effects of seepage toward bottom of tunnel require either continuous support for lower ends of ribs or circular ribs |
| VII. | Squeezing rock - moderate depth | (1.10-2.10) (B+H ₁) | Heavy side pressure, invert struts required. Circular ribs are recommended |
| VIII. | Squeezing rock -great depth | (2.10-4.50)(B+H ₁) | -do- |
| IX. | Swelling rock | Upto 250 ft. (80m), irrespective of the value of (B+H ₁) | Circular ribs are required. In extreme cases, use of yielding support recommended |

Notations: B = tunnel span in metres; H₁ = Height of the opening in metres and H_p = height of the loosened rock mass above tunnel crown developing load (Figure 5.1)

Limitations

Terzaghi's approach was successfully used earlier when conventional drill and blast method of excavation and steel - arch supports were employed in the tunnels of comparable size. This practice lowered the strength of the rock mass and permitted significant roof convergence which mobilized a zone of loosened rock mass from the tunnel roof. The height of this loosened rock mass, called 'coffin cover', acted as dead load on the supports. Cecil (1970) concluded that Terzaghi's classification provided no quantitative information regarding the rock mass properties.

Despite all these limitations, the immense practical values of Terzaghi's approach cannot be denied and this method still finds application under conditions similar to those for which it was developed.

TABLE 5.3
TERZAGHI'S ROCK LOAD CONCEPT AS MODIFIED BY DEERE ET AL. (1970)

| Rock Class & Condition | RQD % | Rock Load H_p | Remarks |
|---------------------------------------|--------|---|--|
| I. Hard and intact | 95-100 | Zero | same as Table 5.2 |
| II. Hard stratified or schistose | 90-99 | 0-0.5B | same as Table 5.2 |
| III. Massive moderately jointed | 85-95 | 0-0.25B | same as Table 5.2 |
| IV. Moderately blocky and seamy | 75-85 | 0.25B-0.35 (B+H _t) | Types IV, V, and VI reduced by about 50 % from Terzaghi values because water table has little effect on rock load (Terzaghi, 1946; Brekke, 1968) |
| V. Very blocky and seamy | 30-75 | (0.2-0.6) (B+H _t) | same as above |
| VI. Completely crushed | 3-30 | (0.6-1.10) (B+H _t) | same as above |
| VIa. Sand and gravel | 0-3 | (1.1-1.4) (B+H _t) | same as above |
| VII. Squeezing rock at moderate depth | NA | (1.10-2.10) (B+H _t) | same as Table 5.2 |
| VIII. Squeezing rock at great depth | NA | (2.10-4.50) (B+H _t) | same as Table 5.2 |
| IX. Swelling rock | NA | Upto 80m irrespective of the value of (B+H _t) | same as Table 5.2 |

NOTATIONS: B = tunnel span; H_t = height of the opening and H_p = height of the loosened rock mass above the tunnel crown developing load (Figure 5.1)

With the advent of the New Austrian Tunnelling Method (NATM) and Norwegian Method of Tunnelling (NMT), increasing use is made of controlled blasting and machine excavation techniques and support system employing reinforced shotcrete and rock bolts. Even in steel arch supported tunnels, wooden struts have been replaced by pneumatically filled lean concrete. These improvements in the tunnelling technology preserve the pre-excavation strength of the rock mass and use it as a load carrying structure in order to minimize roof convergence and restrict the height of the loosening zone above the tunnel crown.

Consequently, the support pressure does not increase directly with the opening width. Based on this argument, Barton et al. (1974) advocated that the support pressure is independent of opening width in rock tunnels. Rock mass-tunnel support interaction analysis of Verman (1993) also suggests that the support pressure is practically independent of the tunnel width, provided support stiffness is not lowered. Goel et al. (1996) also studied this aspect of effect of tunnel size on support pressure and found that there is a negligible effect of tunnel size on support pressure in non-squeezing ground conditions, but the tunnel size could have

considerable influence on the support pressure in squeezing ground condition. This aspect has been covered in details in Chapter 9.

The estimated support pressures from Table 5.2 have been compared with the measured values and the following conclusions emerge

- (i) Terzaghi's method provides reasonable support pressure values for small tunnels (dia. up to 6m),

TABLE 5.4
GUIDELINES FOR SELECTION OF STEEL SETS FOR 6M TO 12M DIAMETER
TUNNELS IN ROCK (DEERE ET AL., 1970)

| Rock Quality | Construction Method | Steel Sets | | Rock Bolt | | Shotcrete | | Additional Supports |
|---|---------------------|--------------------------|---------------------------|---------------------------|--|-------------------------------|--------------|---|
| | | Weight of Steel Sets | Spacing | Spacing of Pattern Bolt | Additional Requirements | Total Thickness (cm) | | |
| | | | | | | Crown | Sides | |
| Excellent RQD > 90 | Boring Machine | Light | None to occasional | None to Occasional | Rare | None to Occasional | None | None |
| | Drilling & Blasting | Light | None to Occasional | None to Occasional | Rare | None to Occasional | None | None |
| Good RQD 75 to 90 | Boring Machine | Light | Occasional to 1.5 to 1.8m | Occasional to 1.5 to 1.8m | Occasional mesh and straps | Local Application 5 to 7.5cm | None | None |
| | Drilling & Blasting | Light | 1.5 to 1.8m | 1.5 to 1.8m | Occasional mesh or straps | Local application 5 to 7.5cm | None | None |
| Fair RQD 50 to 75 | Boring Machine | Light to Medium | 1.5 to 1.8m | 1.2 to 1.8m | Mesh and straps as required | 5 to 10cm | None | Rock bolts |
| | Drilling & Blasting | Light to Medium | 1.2 to 1.5m | 0.9 to 1.5m | Mesh and straps as required | 10cm or more | 10cm or more | Rock bolts |
| Poor RQD 25 to 50 | Boring Machine | Medium circular | 0.6 to 1.2m | 0.9 to 1.5m | Anchorage may be hard to obtain. Considerable mesh and straps required | 10 to 15cm | 10 to 15cm | Rockbolt as required (1.2 to 1.8m center to center) |
| | Drilling & Blasting | Medium to Heavy circular | 0.2 to 1.2m | 0.6 to 1.2m | as above | 15 cm or more | 15cm or more | as above |
| Very Poor RQD < 25 | Boring Machine | Medium to Heavy Circular | 0.6m | 0.6 to 1.2m | Anchorage may be impossible. 100 percent mesh and straps required | 15cm or more on whole section | | Medium sets as required |
| | Drilling & Blasting | Heavy circular | 0.6m | 0.9m | as above | 15cm or more on whole section | | Medium to heavy sets as required |
| Very Poor Squeezing and Swelling Ground | Both methods | Very Heavy circular | 0.6m | 0.6 to 0.9m | Anchorage may be impossible. 100 per cent mesh and straps required | 15cm or more on whole section | | Heavy sets as required |

- (ii) It provides over-safe estimates for large tunnels and caverns (dia. 6 to 14m), and
- (iii) The estimated support pressure values fall in a large range for squeezing and swelling ground conditions for a meaningful application.

5.4 Modified Terzaghi's Theory for Tunnels and Caverns

Singh et al. (1995) have compared support pressure measured from tunnels and caverns with estimates from Terzaghi's rock load theory and found that the support pressure in rock tunnels and caverns does not increase directly with excavation size as assumed by Terzaghi (1946) and others due mainly to dilatant behaviour of rock masses, joint roughness and prevention of loosening of rock mass by improved tunnelling technology. They have subsequently recommended ranges of support pressures as given in Table 5.5 for both tunnels and caverns for the benefit of those who still want to use Terzaghi's rock load approach.

TABLE 5.5
RECOMMENDATIONS OF SINGH ET AL. (1995) ON SUPPORT PRESSURE FOR ROCK TUNNELS AND CAVERNS

| Terzaghi's Classification | | | Classification of Singh et al., 1995 | | | | Remarks |
|---------------------------|--|----------------------|--------------------------------------|---|----------------------------------|------------|--|
| Category | Rock Condition | Rock Load Factor Hp | Category | Rock Condition | Recommended Support Pressure MPa | | |
| | | | | | pv | ph | |
| (1) | (2) | (3) | (4) | (5) | (6) | (7) | (8) |
| I | Hard & intact | 0 | I | Hard & intact | 0 | 0 | -- |
| II | Hard stratified or schistose | 0 to 0.25B | II | Hard stratified or schistose | 0.0-0.04 | 0 | -- |
| III | Massive, moderately jointed | 0 to 0.5B | III | Massive, moderately jointed | 0.04-0.07 | 0 | -- |
| IV | Moderately blocky seamy & jointed | 0.25B to 0.35 (B+Ht) | IV | Moderately blocky seamy very jointed | 0.07-0.1 | 0-0.2 pv | Inverts may be required |
| V | Very blocky & seamy, shattered arched | 0.35 to 1.1 (B+Ht) | V | Very blocky & seamy, shattered highly jointed, thin shear zone or fault | 0.1-0.2 | 0-0.5 pv | Inverts may be required, arched roof preferred |
| VI | Completely crushed but chemically intact | 1.1 (B+Ht) | VI | Completely crushed but chemically unaltered, thick shear and fault zone | 0.2-0.3 | 0.3-1.0 pv | Inverts essential, arched roof essential |
| VII | Squeezing rock at moderate depth | 1.1 to 2.1 (B+Ht) | VII | Squeezing rock condition | | | |

TABLE 5.5 (Continued)

| (1) | (2) | (3) | (4) | (5) | (6) | (7) | (8) |
|---------------|----------------------------------|-------------------|------|--|---------|---|---|
| VII Contd. | Squeezing rock at moderate depth | 1.1 to 2.1 (B+Ht) | VII | A. mild squeezing (u_a/a upto 3%) | 0.3-0.4 | Depends on primary stress values ph may exceed pv | Inverts essential. In excavation flexible support preferred. Circular section recommended |
| | | | | B. moderate squeezing ($u_a/a = 3$ to 5%) | 0.4-0.6 | -do- | -do- |
| VIII | Squeezing rock at great depth | 2.1 to 4.5 (B+Ht) | VII | C. high squeezing ($u_a/a > 5\%$) | 6.0-1.4 | -do- | -do- |
| IX | Swelling rock | upto 80m | VIII | Swelling rock | | | |
| | | | | A. mild swelling | 0.3-0.8 | Depends on type & content of swelling clays, ph may exceed pv | Inverts essential in excavation, arched roof essential |
| | | | | B. moderate swelling | 0.8-1.4 | -do- | -do- |
| | | | | C. high swelling | 1.4-2.0 | -do- | -do- |

Notations: p_v = vertical support pressure; p_h = horizontal support pressure; B = width or span of opening; Ht = height of opening; u_a = radial tunnel closure; a = B/2: thin shear zone = upto 2m thick

It is interesting to note that the recommended roof support pressures turn out to be the same as those obtained from Terzaghi's rock load factors when B and Ht are substituted by 5.5m. The estimated roof support pressures from Table 5.5 were found comparable with the measured values irrespective of the opening size and the rock conditions (Singh et al., 1995). They have further cautioned that the support pressure is likely to increase directly with the excavation width for tunnel sections through slickensided shear zones, thick clay-filled fault gouges, weak clay shales and running or flowing ground conditions where interlocking of blocks is likely to be missing or where joint strength is lost and rock wedges are allowed to fall due to excessive roof convergence on account of delayed supports beyond stand-up time. It may be noted that wider tunnels shall require reduced spacing of bolts or steel arches and thicker linings since rock loads increase directly with the excavation width even if the support pressure does not increase with the tunnel size.

References

Brekke, T.L. (1968). Blocky and Seamy Rock in Tunnelling, *Bull. Assoc. Eng. Geol.*, Vol. 5 No. 1, pp. 1-12.

Terzaghi's rock load theory

- Cecil, O.S. (1970). Correlation of Rock Bolts - Shotcrete Support and Rock Quality Parameters in Scandinavian Tunnels, *Ph.D. Thesis, University of Illinois, Urbana*, p.414.
- Deere, D. U., Peck, R. B., Parker, H., Monsees, J.E. and Schmidt, B. (1970). Design of Tunnel Support Systems, *High Res. Rec.*, **No. 339**, pp. 26-33.
- Goel, R.K., Jethwa, J.L. and Dhar, B.B. (1996). Effect of Tunnel Size on Support Pressure, Technical Note, *Int. Jr. Rock Mech. and Min. Sci. & Geomech. Abstr.*, Pergamon, **Vol. 33, No. 7**, pp. 749-755.
- Rose, D. (1982). Revising Terzaghi's Tunnel Rock Load Coefficients, Proc. 23rd U.S.Sym. Rock Mech., *AIME*, New York, pp. 953-960.
- Singh, Bhawani, Jethwa, J. L. and Dube , A. K. (1995). A Classification System for Support Pressure in Tunnels and Caverns, *Jr. Rock Mech. & Tunnelling Technology*, Pergamon, India, **Vol. 1, No., 1**, January, pp.13-24.
- Sinha, R. S. (1989). *Underground Structures - Design and Instrumentation*, Elsevier Science, U.K., p. 480.
- Terzaghi, K. (1946). *Rock Defects and Load on Tunnel Supports, Introduction to Rock Tunnelling with Steel Supports*, a book by Proctor, R.V. and White, T. L., Commercial Sheering & Stamping Co., Youngstown, Ohio, U.S.A.
- Verman, M. K. (1993). Rock Mass - Tunnel Support Interaction Analysis, *Ph. D. Thesis, University of Roorkee, Roorkee, India*, p.258.

CHAPTER - 6

ROCK MASS RATING (RMR)

"Effectiveness of knowledge through research (E) is $E = mc^2$; where m is mass of knowledge and c is communication of knowledge by publications"

Z. T. Bieniawski

6.1 Introduction

The geomechanics classification or the rock mass rating (RMR) system was initially developed at the South African Council of Scientific and Industrial Research (CSIR) by Bieniawski (1973) on the basis of his experiences in shallow tunnels in sedimentary rocks (Kaiser et al., 1986). Since then the classification has undergone several significant changes: in 1974 - reduction of classification parameters from 8 to 6; in 1975 - adjustment of ratings and reduction of recommended support requirements; in 1976 - modification of class boundaries to even multiples of 20; in 1979 - adoption of ISRM (1978) rock mass description, etc. It is, therefore, important to state which version is used when RMR-values are quoted. The geomechanics classification reported in Bieniawski (1984) is referred in this book.

To apply the geomechanics classification system, a given site should be divided into a number of geological structural units in such a way that each type of rock mass is represented by a separate geological structural unit. The following six parameters are determined for each structural unit:

- (i) uniaxial compressive strength of intact rock material,
- (ii) rock quality designation RQD,
- (iii) joint or discontinuity spacing,
- (iv) joint condition,
- (v) ground water condition, and
- (vi) joint orientation.

6.2 Collection of Field Data

The rating of six parameters of the RMR system are given in Tables 6.1 to 6.6. For eliminating doubts due to subjective judgements, the rating for different parameters should be given a range in preference to a single value. These six parameters are discussed in the following paragraphs.

Rock mass rating (RMR)

6.2.1 Uniaxial Compressive Strength of Intact Rock Material (q_c)

The strength of the intact rock material should be obtained from rock cores in accordance with site conditions. The ratings based on uniaxial compressive strength (which is preferred) and point load strength are both given in Table 6.1.

TABLE 6.1
STRENGTH OF INTACT ROCK MATERIAL (BIENIAWSKI, 1979)

| Qualitative Description | Compressive Strength (MPa) | Point Load Strength (MPa) | Rating |
|-------------------------|----------------------------|---|--------|
| Exceptionally strong | > 250 | 8 | 15 |
| Very strong | 100 -250 | 4-8 | 12 |
| Strong | 50 -100 | 2-4 | 7 |
| Average | 25 - 50 | 1-2 | 4 |
| Weak | 10 - 25 | use of uniaxial compressive strength is preferred | 2 |
| Very weak | 2 - 10 | -do- | 1 |
| Extremely weak | 1- 2 | -do- | 0 |

Note: At compressive strength less than 0.6 MPa, many rock material would be regarded as soil

6.2.2 Rock Quality Designation (RQD)

Rock quality designation (RQD) should be determined as discussed in Chapter 4. The details of rating are given in Table 6.2.

TABLE 6.2
ROCK QUALITY DESIGNATION RQD (BIENIAWSKI, 1979)

| Qualitative Description | RQD | Rating |
|-------------------------|----------|--------|
| Excellent | 90 - 100 | 20 |
| Good | 75 - 90 | 17 |
| Fair | 50 - 75 | 13 |
| Poor | 25 - 50 | 8 |
| Very poor | < 25 | 3 |

6.2.3 Spacing of Discontinuities

The term discontinuity covers joints, beddings or foliations, shear zones, minor faults, or other surfaces of weakness. The linear distance between two adjacent discontinuities should be measured for all sets of discontinuities and the rating should be obtained from Table 6.3 for the most critical discontinuity.

TABLE 6.3
SPACING OF DISCONTINUITIES (BIENIAWSKI, 1979)

| Description | Spacing (m) | Rating |
|-------------|-------------|--------|
| Very wide | > 2 | 20 |
| Wide | 0.6 - 2 | 15 |
| Moderate | 0.2 - 0.6 | 10 |
| Close | 0.06- 0.2 | 8 |
| Very close | < 0.06 | 5 |

Note: If more than one discontinuity sets are present and the spacing of discontinuities of each set varies, consider the set with lowest rating

6.2.4 Condition of Discontinuities

This parameter includes roughness of discontinuity surfaces, their separation, length or continuity, weathering of the wall rock or the planes of weakness, and infilling (gouge) material. The details of rating are given in Table 6.4.

TABLE 6.4
CONDITION OF DISCONTINUITIES (BIENIAWSKI, 1979)

| Description | Rating |
|--|--------|
| Very rough and unweathered, wall rock tight and discontinuous, no separation | 30 |
| Rough and slightly weathered, wall rock surface separation <1mm | 25 |
| Slightly rough and moderately to highly weathered, wall rock surface separation <1mm | 20 |
| Slickensided wall rock surface or 1-5mm thick gouge or 1-5mm wide continuous discontinuity | 10 |
| 5mm thick soft gouge, 5mm wide continuous discontinuity | 0 |

6.2.5 Ground Water Condition

In the case of tunnels, the rate of inflow of ground water in litres per minute per 10m length of the tunnel should be determined, or a general condition can be described as completely dry, damp, wet, dripping, and flowing. If actual water pressure data are available, these should be stated and expressed in terms of the ratio of the seepage water pressure to the major principal stress. The ratings as per the water condition are shown in Table 6.5.

Ratings of the above five parameters (Tables 6.1 to 6.5) are added to obtain what is called the basic rock mass rating RMR_{basic} .

6.2.6 Orientation of Discontinuities

Orientation of discontinuities means the strike and dip of discontinuities. The strike should be recorded with reference to magnetic north. The dip angle is the angle between the horizontal and the discontinuity plane taken in a direction in which the plane dips. The value of the dip and the strike should be recorded as shown in Table 6.6. In addition, the orientation of tunnel axis or slope face or foundation alignment should also be recorded.

The influence of the strike and the dip of the discontinuities is considered with respect to the direction of tunnel drivage or slope face orientation or foundation alignment. To facilitate a decision whether the strike and the dip are favourable or not, reference should be made to Tables 6.7 and 6.8 which provide a quantitative assessment of critical joint orientation effect with respect to tunnels and dams foundations respectively. Once the ratings for the effect of the critical discontinuity is known, as shown in Table 6.9 an arithmetic sum of the joint adjustment rating and the RMR_{basic} is obtained. This number is called the final rock mass rating RMR.

TABLE 6.5
GROUND WATER CONDITION (BIENIAWSKI, 1979)

| | | | | | |
|---|----------------|-------|---------|----------|---------|
| Inflow per 10m tunnel length (litre/min.) | none | <10 | 10-25 | 25-125 | >125 |
| Joint water pressure / major principal stress | 0 | 0-0.1 | 0.1-0.2 | 0.2-0.5 | >0.5 |
| General description | completely dry | damp | wet | dripping | flowing |
| Rating | 15 | 10 | 7 | 4 | 0 |

TABLE 6.6
ORIENTATION OF DISCONTINUITIES

| | | |
|---------|---|----------|
| A. | Orientation of tunnel/slope/foundation axis | |
| B. | Orientation of discontinuities: | |
| set - 1 | Average strike.....(from.....to.....) | Dip..... |
| set - 2 | Average strike.....(from.....to.....) | Dip..... |
| set - 3 | Average strike.....(from.....to.....) | Dip..... |

TABLE 6.7
ASSESSMENT OF JOINT ORIENTATION EFFECT ON TUNNELS
(DIPS ARE APPARENT DIPS ALONG TUNNEL AXIS) (BIENIAWSKI, 1989)

| Strike Perpendicular to Tunnel Axis | | | | Strike Parallel to Tunnel Axis | | Irrespective of Strike |
|-------------------------------------|-------------|-------------------|--------------|--------------------------------|-------------------|------------------------|
| Drive with dip | | Drive against dip | | | | |
| Dip 45° - 90° | Dip 20°-45° | Dip 45°-90° | Dip 20°-45° | Dip 20°-45° | Dip 45° - 90° | Dip 0° - 20° |
| Very favourable | Favourable | Fair | Unfavourable | Fair | Very unfavourable | Fair |

TABLE 6.8
ASSESSMENT OF JOINT ORIENTATION EFFECT ON STABILITY OF DAM FOUNDATION

| Dip 0° - 10° | Dip 10° - 30° | | Dip 30° - 60° | Dip 60° - 90° |
|-----------------|---------------|------------|---------------|-------------------|
| | Dip Direction | | | |
| | Upstream | Downstream | | |
| Very favourable | Unfavourable | Fair | Favourable | Very unfavourable |

TABLE 6.9
ADJUSTMENT FOR JOINT ORIENTATION (BIENIAWSKI, 1979)

| Joint Orientation Assessment for | Very Favourable | Favourable | Fair | Unfavourable | Very Unfavourable |
|----------------------------------|-----------------|------------|------|--------------|-------------------|
| Tunnels | 0 | -2 | -5 | -10 | -12 |
| Raft foundation | 0 | -2 | -7 | -15 | -25 |
| Slopes* | 0 | -5 | -25 | -50 | -60 |

* It is recommended to see slope mass rating (SMR) in Chapter 17

6.3 Estimation of Rock Mass Rating (RMR)

The rock mass rating should be determined as an algebraic sum of ratings for all the parameters given in Table 6.1 to 6.5 and Table 6.9 after adjustments for orientation of discontinuities given in Table 6.7 and 6.8. The sum of ratings for four parameters (Table 6.2 to 6.5) is called Rock Condition Rating (RCR) which discounts the effect of compressive strength of intact rock material and orientation of joints (Goel et al., 1996). Heavy blasting creates new fractures. Experience suggests that 10 points should be added to get RMR for undisturbed rock masses in situations where TBMs or road headers are used for tunnel excavation 3 to 5 points may be added depending upon the quality of the controlled blasting.

On the basis of RMR values for a given engineering structure, the rock mass is classified in five classes named as very good (RMR 100-81), good (80-61), fair (60-41), poor (40-21) and very poor (<20) as shown in Table 6.10.

Rock mass rating (RMR)

TABLE 6.10
DESIGN PARAMETERS & ENGINEERING PROPERTIES OF
ROCK MASS (BIENIAWSKI, 1979 & BIS CODE)

| S. No. | Parameter/ Properties of Rock Mass | Rock Mass Rating (Rock Class) | | | | |
|--------|---|-------------------------------|----------------------|---------------------|----------------------|----------------------|
| | | 100-81 (I) | 80-61 (II) | 60-41 (III) | 40-21 (IV) | <20 (V) |
| 1. | Classification of rock mass | Very good | Good | Fair | Poor | Very poor |
| 2. | Average stand-up time | 10 years for 15 m span | 6 months for 8m span | 1 week for 5 m span | 10 hrs for 2.5m span | 30 min. for 1 m span |
| 3. | Cohesion of rock mass (MPa)* | > 0.4 | 0.3-0.4 | 0.2-0.3 | 0.1-0.2 | <0.1 |
| 4. | Angle of internal friction of rock mass | > 45° | 35°-45° | 25°-35° | 15°-25° | 15° |

* These values are applicable to slopes only in saturated and weathered rock mass

In case of wider tunnels and caverns, RMR may be somewhat less than obtained from drifts. Because in drifts, one may miss intrusions of weaker rocks and joint sets having lower joint condition ratings.

Separate RMR should be obtained for tunnels of different orientations after taking into account the orientation of tunnel axis with respect to the critical joint set (Table 6.6).

The classification can be used for estimating many useful parameters such as the unsupported span, the stand-up time or the bridge action period and the support pressure for an underground opening as shown in the following paragraphs under Art. 6.4. It can also be used for selecting a method of excavation and the permanent support system. Further, cohesion, angle of internal friction, deformation modulus of the rock mass and allowable bearing pressure may also be estimated. It is emphasized that the correlations suggested in Art. 6.4 should be used for feasibility studies and preliminary designs only. In-situ tests, supported with numerical modelling could be essential, particularly for a large opening such as a cavern.

6.4 Applications of RMR

The following engineering properties of rock masses can be obtained using RMR. If the rock mass rating lies within a given range, the value of engineering properties may be interpolated between the recommended range of properties.

6.4.1 Average Stand-up Time for Arched Roof

The stand-up time depends upon effective span of the opening which is defined as the width of the opening or the distance between the tunnel face and the last support, whichever is smaller. For arched openings the stand-up time would be significantly higher than that for a

flat roof. Controlled blasting will further increase the stand-up time as damage to the rock mass is decreased. For the tunnels with arched roof the stand-up time is related with the rock mass class in Table 6.10 (Figure 6.1). It is important that one should not unnecessarily delay supporting the roof in the case of a rock mass with high stand-up time as this may lead to deterioration in the rock mass which ultimately reduces the stand-up time.

Lauffer (1988) observed that the stand-up time improves by one class of RMR value in case of excavations by TBM.

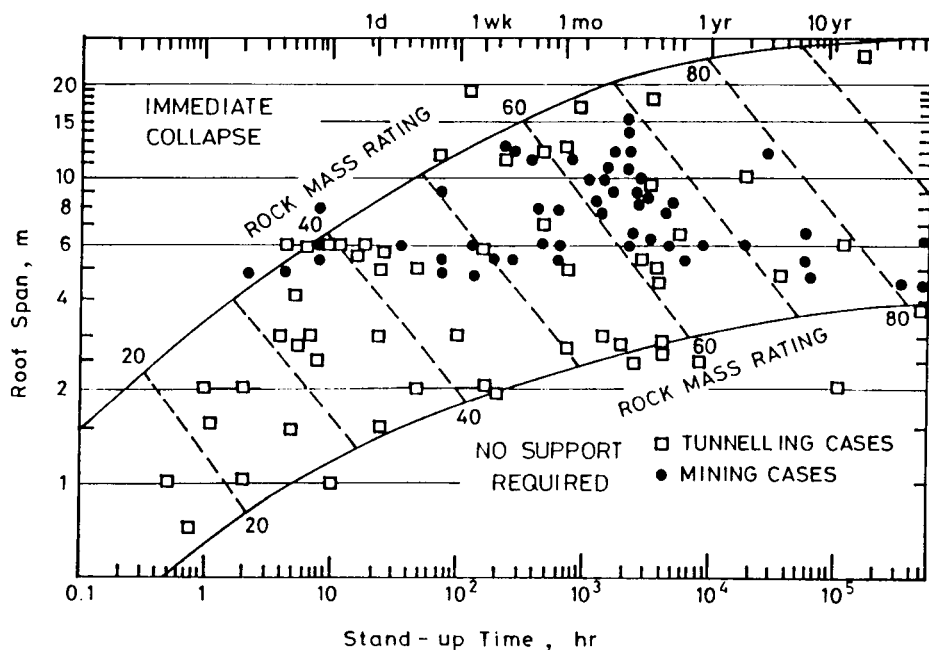

Figure 6.1: Stand-up time vs roof span for various rock mass classes as per geomechanics classification (Bieniawski, 1989)

6.4.2 Cohesion and Angle of Internal Friction

Assuming that a rock mass behaves as a Coulomb material, its shear strength will depend upon cohesion and angle of internal friction. RMR is used to estimate the cohesion and angle of internal friction (Table 6.10). Usually the strength parameters are different for peak failure and residual failure conditions. In Table 6.10, only peak failure values are given. It is experienced that these values are applicable to slopes only in saturated and weathered rock masses. The cohesion is one order of magnitude higher in the case of tunnels because joints are relatively tight and widely spaced.

6.4.3 Modulus of Deformation

Following correlations are suggested for determining modulus of deformation of rock masses.

Modulus reduction factor - Figure 6.2 gives a correlation between rock mass rating RMR and modulus reduction factor MRF, which is defined as a ratio of deformation modulus of a rock mass to the elastic modulus of the rock material obtain from core. Thus, deformation modulus of a rock mass can be determined as a product of the modulus reduction factor corresponding to a given rock mass rating (Figure 6.2) and the elastic modulus of the rock material (E_r) from the following equation (Singh, 1979),

$$E_d = E_r \cdot \text{MRF} \tag{6.1a}$$

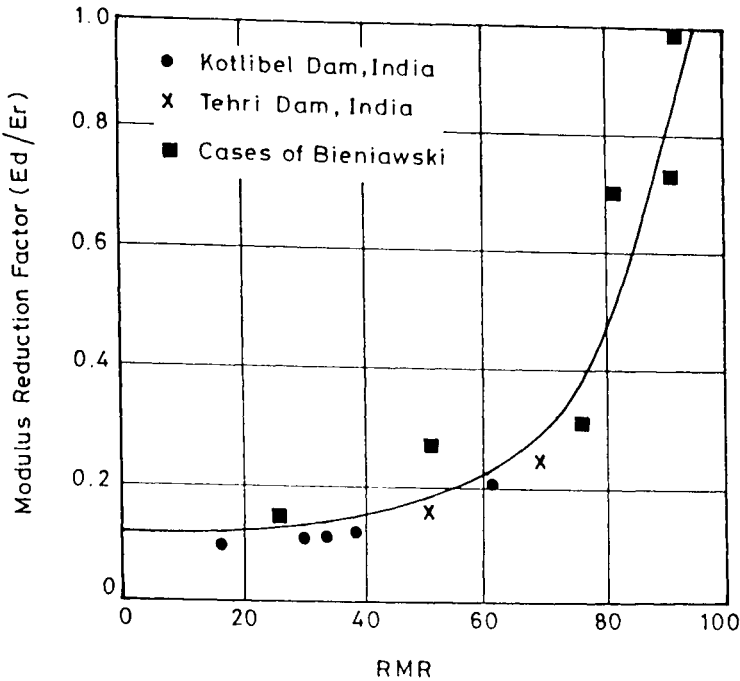

Figure 6.2: Relationship between rock mass rating (RMR) and modulus reduction factor (Singh, 1979)

Nicholson and Bieniawski (1990) have developed an empirical expression for modulus reduction factor (MRF), Eqn. 6.1b. This factor is calculated in order to derive modulus of deformation for a rock mass using its RMR and Young's modulus or modulus of elasticity,

$$\text{MRF} = \frac{E_d}{E_r} = 0.0028 \text{RMR}^2 + 0.9 \cdot e^{(\text{RMR}/22.82)} \tag{6.1b}$$

Mitri et al. (1994) used the following equation to derive the modulus of deformation of rock masses:

$$\text{MRF} = \frac{E_d}{E_r} = 0.5 \cdot [1 - \cos(\pi \cdot \text{RMR}/100)] \quad (6.1c)$$

There is an approximate correlation between modulus of deformation and rock mass rating suggested by Bieniawski (1978) for hard rock masses ($q_c > 100$ MPa).

$$E_d = 2 \text{ RMR} - 100, \quad \text{GPa (applicable for RMR} > 50) \quad (6.2)$$

Serafim and Pereira (1983) suggested the following correlation

$$E_d = 10^{(\text{RMR}-10) \cdot 40}, \quad \text{GPa (applicable for RMR} < 50 \text{ also)} \quad (6.3a)$$

These correlations are shown in Figure 6.3. Here q_c means average uniaxial crushing strength of the intact rock material in MPa.

Hoek and Brown (1997) suggested a correction in Eqn. 6.3a (also see Chapter 25),

$$E_d = \frac{\sqrt{q_c}}{10} 10^{(\text{RMR}-10) \cdot 40} \text{ GPa, } q_c \leq 100 \text{ MPa} \quad (6.3b)$$

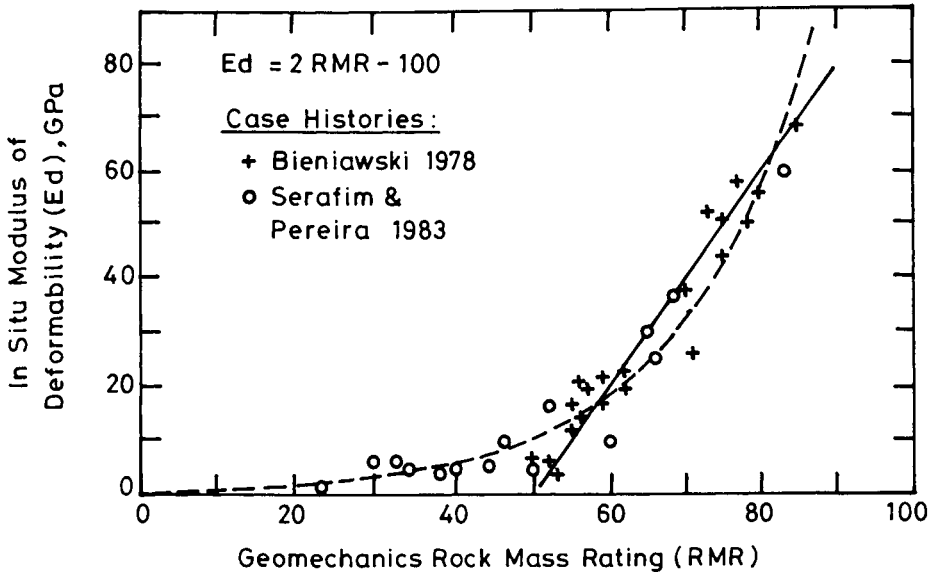

Figure 6.3: Correlation between modulus of deformation of rock masses and RMR (Bieniawski, 1984)

Rock mass rating (RMR)

The modulus of deformation of a dry and weak rock mass ($q_c < 100$ MPa) around underground openings located at depths exceeding 50m is dependent upon confining pressure due to overburden and may be determined by the following correlation (Verman, 1993)

$$E_d = 0.3 H^\alpha \cdot 10^{(RMR-20) / 38}, \quad \text{GPa} \quad (6.4)$$

where,

- α = 0.16 to 0.30 (higher for poor rocks), and
- H = depth of location under consideration below ground surface in metres.
- ≥ 50m

The modulus of deformation of poor rock masses with water sensitive minerals decreases significantly after saturation and with passage of time after excavation. For design of dam foundations, it is recommended that uniaxial jacking tests should be conducted very carefully soon after the excavation of drifts, particularly for poor rock masses in saturated condition.

6.4.4 Allowable Bearing Pressure

Allowable bearing pressure is also related to RMR and may be estimated from Table 19.2 in Chapter 19.

6.4.5 Shear Strength of Rock Masses

Table 15.1 summarises the non-linear shear strength equations for various rock mass ratings, degree of saturation and rock types. The recommended criteria is based on 43 block shear tests by Mehrotra (1992). It has been realised that for highly jointed rock masses, the shear strength (τ) will not be governed by the strength of the rock material as suggested by Hoek and Brown (1980). The results show that saturation does affect shear strength of rock mass significantly.

For hard and massive rock masses ($RMR > 60$), their shear strength is governed by the first row of Table 15.1 and is proportional to their UCS. It follows that block shear tests on saturated rock blocks should be conducted for design of concrete dams and stability of abutments.

6.4.6 Estimation of Support Pressure

In 1983, Unal, on the basis of his studies in coal mines, proposed the following correlation for estimation of support pressure using RMR for openings with flat roof,

$$p_v = \left[\frac{100 - RMR}{100} \right] \cdot \gamma \cdot B \quad (6.5)$$

where,

- p_v = support pressure,
- γ = rock density, and
- B = tunnel width.

Goel and Jethwa (1991) have evaluated Eqn. 6.5 for application to rock tunnels with arched roof by comparing the measured support pressures with estimates from Eqn. 6.5. The comparison shows that Eqn. 6.5 is not applicable to rock tunnels. They found that the estimated support pressures were unsafe for all sizes of tunnels under squeezing ground conditions. Further, the estimates for non-squeezing ground conditions were unsafe for small tunnels (dia. upto 6m) and oversafe for large tunnels (dia > 9m) which implies that the size effect is over-emphasized for arched openings. This observation is logical since bending moments in a flat roof increase geometrically with the opening unlike in an arched roof.

Subsequently, using the measured support pressure values from 30 instrumented Indian tunnels, Goel and Jethwa (1991) have proposed Eqn. 6.6 for estimating the short-term support pressure for underground openings in both squeezing and non-squeezing ground conditions in the case of tunnelling by conventional blasting method using steel rib supports:

$$p_v = \frac{0.75 \cdot B^{0.1} \cdot H^{0.5} - RMR}{2 RMR}, \text{ MPa} \quad (6.6)$$

where,

- B = span of opening in metres,
- H = overburden or tunnel depth in metres (>50m), and
- p_v = short-term roof support pressure in MPa.

Bieniawski (1989) provided guidelines for selection of tunnel supports (Table 6.11). This is applicable to tunnels excavated with conventional drilling and blasting method. These guidelines depend upon the factors like depth below surface (to take care of overburden pressure or the insitu stress), tunnel size and shape and method of excavation. The support measures in Table 6.11 are the permanent and not the temporary or primary supports.

6.5 Inter-relation Between RMR and Q

An inter-relation was proposed between the RMR and the Q (Bieniawski, 1976) based on 111 case histories. The correlation is

$$RMR = 9 \ln Q + 44 \quad (6.7)$$

The correlation in Eqn. 6.7 is quite popular despite a low reliability. A more realistic approach for inter-relation between RMR and Q is proposed by Goel et al. (1996) as presented in Chapter 9.

6.6 Precautions

It must be ensured that double accounting for a parameter should not be done in the analysis of rock structures and estimating rating of a rock mass. For example, if pore water pressure is

Rock mass rating (RMR)

TABLE 6.11
GUIDELINES FOR EXCAVATION AND SUPPORT OF ROCK TUNNELS IN ACCORDANCE
WITH THE ROCK MASS RATING SYSTEM (BIENIAWSKI, 1989)

| Rock Mass Class | Excavation | Supports | | |
|------------------------------|--|--|---|---|
| | | Rock bolts (20mm dia fully Grouted) | Shotcrete | Steel sets |
| Very good rock RMR=81-100 | Full face. 3 m advance | Generally, no support required except for occasional spot bolting | | |
| Good rock RMR = 61-80 | Full face. 1.0 - 1.5m advance. Complete support 20m from face | Locally. bolts in crown 3m long, spaced 2.5m. with occasional wire mesh | 50mm in crown where required | None |
| Fair rock RMR = 41-60 | Heading and bench. 1.5 - 3m advance in heading. Commence support after each blast. Complete support 10m from face | Systematic bolts 4m long spaced 1.5 - 2m in crown and walls with wire mesh in crown | 50-100 mm in crown and 30mm in sides | None |
| Poor rock RMR = 21-40 | Top heading and bench. 1.0-1.5 m advance in top heading. Install support concurrently with excavation 10m from face | Systematic bolts 4-5 m long, spaced 1 - 1.5 m in crown and wall with wire mesh | 100-150 mm in crown and 100 mm in sides | Light to medium ribs spaced 1.5 m where required |
| Very poor rock RMR <20 | Multiple drifts 0.5 - 1.5 m advance in top heading. Install support concurrently with excavation. Shotcrete as soon as possible after blasting | Systematic bolts 5 -6 m long spaced 1-1.5 m in crown and walls with wire mesh. Bolt invert | 150-200 mm in crown 150mm in sides and 50mm on face | Medium to heavy ribs spaced 0.75m with steel lagging and forepoling if required. Close invert |

being considered in the analysis of rock structures, it should not be accounted for in RMR. Similarly, if orientation of joint sets is considered in stability analysis of rock slopes, the same should not be accounted for in RMR.

It is cautioned that the RMR system is found to be unreliable in very poor rock masses. Care should therefore be exercise to apply the RMR system in such rock mass.

Rigorous approaches of designs based on various parameters could lead to uncertain results because of uncertainties in obtaining correct values of input parameters at a given site of tunnelling. Rock mass classifications which do not involve uncertain parameters follow the philosophy of reducing uncertainties.

In tunnelling, it is also important to assess the tunnelling conditions on which excavation method, support pressure and type of support will depend significantly. The next chapter deals with the prediction of tunnelling conditions.

References

- BIS Codes: Guidelines for Classification System on Rock Mass. Part I - for Predicting Engineering Properties (RMR Method). *Bureau of Indian Standards*, New Delhi, India.
- Bieniawski, Z.T.(1973). Engineering Classification of Jointed Rock Masses. *The Civil Engineer in South Africa*, **15**, pp. 335-344.
- Bieniawski, Z.T.(1976). Rock Mass Classifications in Rock Engineering. *Proc. of the Sym. on Exploration for Rock Engineering*, Johannesburg, pp. 97-106.
- Bieniawski, Z. T. (1978). Determining Rock Mass Deformability. Experience from Case Histories. *Int. Jr. Rock Mech. and Min. Sci. & Geomech. Abstr.*, Pergamon, **15**, pp. 237-247.
- Bieniawski, Z. T. (1979). The Geomechanics Classification in Rock Engineering Applications. Reprinted from: *Proc. 4th Cong. of the Int. Society for Rock Mech./ Comptes-rendus/ Berichte-Montreux, Suisse*, 2-8 Sept. 1979. 1979. 2208 pp., 3 vols., Hfl. 1390/-, US\$695.00/£463. A. A. Balkema, P.O. Box 1675, Rotterdam, Netherlands.
- Bieniawski, Z. T. (1984). *Rock Mechanics Design in Mining and Tunnelling*, A. A. Balkema, Rotterdam, pp. 97-133.
- Bieniawski, Z.T.(1989). *Engineering Rock Mass Classifications*, John Wiley & Sons, p. 251.
- Goel, R.K. and Jethwa, J.L. (1991). Prediction of Support Pressure using RMR Classification. *Proc. Indian Geotech. Conf.*, Surat, India, pp. 203-205.
- Goel R. K., Jethwa, J. L. and Paithankar, A.G. (1996). Correlation Between Barton's Q and Bieniawski's RMR - A New Approach. *Int. Jr. Rock Mech. and Min. Sci. & Geomech. Abstr.*, Pergamon, **Vol. 33, No. 2**, pp. 179-181
- Hoek, E. and Brown, E.T (1982). *Underground Excavations in Rocks*, Institution of Mining and Metallurgy, London, p.527.
- Hoek, E. and Brown, E.T. (1997). Practical Estimates of Rock Mass Strength. *Int. Jr. Rock Mech. and Min. Sci. and Geomech. Abstr.*, Pergamon, **Vol. 34, No. 8**, pp. 1165-1186.
- ISRM (1978). Description of Discontinuities in a Rock Mass. *Int. Jr. Rock Mech. and Min. Sci. & Geomech. Abstr.*, Pergamon, **15**, pp. 319-368.
- Kaiser, P. K., MacKay, C. and Gale, A.D. (1986). Evaluation of Rock Classifications at B.C. Rail Tumbler Ridge Tunnels, *Rock Mechanics & Rock Engineering*, **19**, pp. 205-234.
- Lauffer, H. (1988). Zur Gebirgsklassifizierung bei Frasnortrieben. *Felsbau*, **6(3)**, pp. 137-149.
- Mehrotra, V. K. (1992). Estimation of Engineering Properties of Rock Mass, *Ph. D. Thesis, University of Roorkee*, Roorkee, India, p. 267.
- Mitri, H. S., Edrissi, R. and Henning, J. (1994). Finite Element Modelling of Cable Bolted Stopes in Hard Rock Underground Mines. *Presented at the SME Annual Meeting*, Albuquerque, pp. 14-17.
- Nicholson, G. A. and Bieniawski, Z. T. (1990). A Non-Linear Deformation Modulus Based on Rock Mass Classification, *Int. J. Min. & Geol. Engg.*, **(8)**, pp. 181-202.
- Serafim, J. L. and Pereira, J. P. (1983). Considerations of the Geomechanics Classification of Bieniawski. *Int. Symp. Eng. Geol. Underground Constr.*, LNEC, Lisbon, **Vol. 1**, pp. II.33 - II.42.
- Singh, Bhawani. (1979). Geological and Geophysical Investigation in Rocks for Engineering Projects. *Int. Symp. In situ Testing of Soils & Performance of Structures*, **Vol. 1**, India, pp. 486-492.
- Unal, E. (1983). Design Guidelines and Roof Control Standards for Coal Mine Roofs. *Ph. D. Thesis, Pennsylvania State University*, University Park, p. 355.
- Verman, M. K. (1993). Rock Mass-Tunnel Support Interaction Analysis. *Ph. D. Thesis, University of Roorkee*, Roorkee, India.

CHAPTER - 7

PREDICTION OF GROUND CONDITIONS FOR TUNNELLING

"The most incomprehensible fact about nature is that it is comprehensible"
Albert Einstein

7.1 Introduction

The knowledge of ground condition plays an important role in selection of excavation method and designing a support system for underground openings. The ground condition could be stable / elastic (and or non-squeezing) or falling / squeezing depending upon the insitu stress and the rock mass strength. A weak over-stressed rock mass would experience squeezing ground condition, whereas a hard and massive over-stressed rock mass may experience rock burst condition. On the other hand, when the rock mass is not over-stressed, the ground condition is termed as stable or elastic.

Tunnelling in elastic and the competent ground condition can again face two situations - one where no supports are required, i.e., a self-supporting condition and the second where supports are required for stability; let us call non-squeezing condition. The squeezing ground condition has been divided into three classes on the basis of tunnel closures by Singh et al. (1995) as mild, moderate and high squeezing ground conditions (Table 5.5).

The world wide experience is that tunnelling through the squeezing ground condition is a very slow and problematic process because the rock mass around the opening loses its inherent strength under the influence of insitu stresses. This may result in mobilization of high support pressure and tunnel closures. Tunnelling under the non-squeezing ground condition, on the other hand, is comparatively safe and easy because the inherent strength of the rock mass is maintained. Therefore, the first important step is to assess whether a tunnel would experience a squeezing ground condition or a non-squeezing ground condition. This decision controls the selection of the excavation method and the support system. For example, a large tunnel which could possibly be excavated full face with light supports, under the non-squeezing ground condition may have to be excavated by heading and bench method with a flexible support system under the squeezing ground condition.

Non-squeezing ground conditions are common in most of the projects. The squeezing conditions are common in the Lower Himalayas in India, Alps and other parts of the world where the rock masses are weak, highly jointed, faulted, folded and tectonically disturbed and the overburden is high.

7.2 The Tunnelling Conditions

Various ground conditions encountered during tunnelling have been summarized in Table 7.1. Table 7.2 suggests the method of excavation, the type of supports and precautions for various ground conditions.

International Society for Rock Mechanics (ISRM) commission on Squeezing Rocks in Tunnels has published *Definitions of Squeezing* which are quoted here (Barla, 1995).

"Squeezing of rock is the time dependent large deformation, which occurs around a tunnel and other underground openings, and is essentially associated with creep caused by exceeding shear strength. Deformation may terminate during construction or continue over a long time period".

TABLE 7.1
CLASSIFICATION OF GROUND CONDITIONS FOR TUNNELLING

| S.No. | Ground Classification | Sub-Class | Rock Behaviour |
|-------|---------------------------|---|--|
| 1. | Competent Self-supporting | ----- | Massive rock mass requiring no support for tunnel stability |
| 2. | Incompetent Non-Squeezing | ----- | Jointed rock mass requiring supports for tunnel stability |
| 2. | Ravelling | ----- | Chunks or flakes of rock mass begin to drop out of the arch or walls after the rock mass is excavated |
| 3. | Squeezing | Mild squeezing ($u_a/a = 1-3\%$) Moderate squeezing ($u_a/a = 3-5\%$) High squeezing ($u_a/a > 5\%$) | Rock mass squeezes plastically into the tunnel and the phenomena is time dependent; rate of squeezing depends upon the degree of overstress; may occur at shallow depths in weak rock masses like shales, clay, etc.; hard rock masses under high cover may experience slabbing popping rock burst |
| 4. | Swelling | | Rock mass absorbs water, increases in volume and expands slowly into the tunnel, e.g. montmorillonite clay |
| 5. | Running | | Granular material becomes unstable within steep shear zones |
| 6. | Flowing | | A mixture of soil like material and water flows into the tunnel. The material can flow from invert as well as from the face crown and wall and can flow for large distances completely filling the tunnel in some cases |
| 7. | Rock Burst | | A violent failure in hard (brittle) & massive rock masses of Class II type (Fig. 3.2), when subjected to high stress |

Notations: u_a = radial tunnel closure; a = tunnel radius; u_a/a = normalised tunnel closure in percentage

Prediction of ground conditions for tunnelling

TABLE 7.2
METHOD OF EXCAVATION, TYPE OF SUPPORTS AND PRECAUTIONS TO BE ADOPTED
FOR DIFFERENT GROUND CONDITIONS

| S.No | Ground Condition | Excavation Method | Type of Support | Precautions |
|------|-----------------------------|---|---|--|
| 1 | Self-Supporting / Competent | TBM or Full face drill and controlled blast | No support or spot bolting with a thin layer of shotcrete to prevent widening of joints | Look out for localised wedge/shear zone Past experience discourages use of TBM if geological conditions change frequently |
| 2 | Non-squeezing / Incompetent | Full face drill and controlled blast by boomers | Flexible support, shotcrete and pre-tensioned rock bolt supports of required capacity. Steel fibre reinforced shotcrete (SFRS) may or may not be required | First layer of shotcrete should be applied after some delay but within the stand-up time to release the strain energy of rock mass |
| 3 | Ravelling | Heading and bench; drill and blast manually | Steel support with struts ; pre-tensioned rock bolts with steel fibre reinforced shotcrete (SFRS) | Expect heavy loads including side pressure |
| 4 | Mild Squeezing | Heading and bench; drill and blast | Full column grouted rock anchors and SFRS. Floor to be shotcreted to complete a support ring | Install support after each blast. circular shape is ideal; side pressure is expected; do not have a long heading which delays completion of support ring |
| 5 | Moderate Squeezing | Heading and bench; drill and blast | Flexible support, full column grouted highly ductile rock anchors and SFRS. Floor bolting to avoid floor heaving & to develop a reinforced rock frame. In case of steel ribs, these should be installed and embedded in shotcrete to withstand high support pressure | Install support after each blast; increase the tunnel diameter to absorb desirable closure; circular shape is ideal; side pressure is expected; instrumentation is essential |
| 6 | High Squeezing | Heading and bench in small tunnels and multiple drift method in large tunnels; use forepoling if stand-up time is low | Very flexible support; full column grouted highly ductile rock anchors and slotted SFRS; yielding steel ribs with struts when shotcrete fails repeatedly, steel ribs may be used to supplement shotcrete to withstand high support pressure; close ring by erecting invert support; encase steel ribs in shotcrete, floor bolting to avoid floor heaving; sometimes steel ribs with loose backfill are also used to release the strain energy in a controlled manner (tunnel closure more than 4 per cent shall not be permitted) | Increase the tunnel diameter to absorb desirable closure; provide invert support as early as possible to mobilise full support capacity, long - term instrumentation is essential; circular shape is ideal |
| 7 | Swelling | Full face or heading and bench; drill and blast | Full column grouted rock anchors with SFRS shall be used around the tunnel, increase 30 % thickness of shotcrete due to weak bond of the shotcrete with rock mass; erect invert strut. The first layer of shotcrete is sprayed immediately to prevent ingress of moisture into rock mass | Increase the tunnel diameter to absorb the expected closure; prevent exposure of swelling minerals to moisture, monitor tunnel closure |
| 8 | Running and Flowing | Multiple drift with forepoles; grouting of the ground is essential; shield tunnelling may be used in soil conditions | Full column grouted rock anchors and SFRS; concrete lining upto face, steel liner in exceptional cases with shield tunnelling | Progress is very slow. Trained crew should to be deployed |
| 9 | Rock Burst | Full face drill and blast | Fibre reinforced shotcrete with full column resin anchors immediately after excavation | Micro-seismic monitoring is essential |

This definition is complemented by the following additional statements:

- * Squeezing can occur in both rock and soil as long as the particular combination of induced stresses and material properties pushes some zones around the tunnel beyond the limiting shear stress at which creep starts.
- * The magnitude of the tunnel convergence associated with squeezing, the rate of deformation, and the extent of the yielding zone around the tunnel depend on the geological conditions, the insitu stresses relative to rock mass strength, the ground water flow and pore pressure, and the rock mass properties.
- * Squeezing of rock masses can occur as squeezing of intact rock, as squeezing of infilled rock discontinuities and / or along bedding and foliation surfaces, joints and faults.
- * Squeezing is synonymous of over-stressing and does not comprise deformations caused by loosening as might occur at the roof or at the walls of tunnels in jointed rock masses. Rock bursting phenomena do not belong to squeezing.
- * Time dependent displacements around tunnels of similar magnitudes as in squeezing ground conditions, may also occur in rocks susceptible to swelling. While swelling always implies volume increase, squeezing does not, except for rocks exhibiting a dilatant behaviour. However, it is recognized that in some cases squeezing may be associated with swelling.
- * Squeezing is closely related to the excavation and support techniques and sequence adopted in tunnelling. If the support installation is delayed, the rock mass moves into the tunnel and a stress re-distribution takes place around it. Conversely, if the rock deformations are constrained, squeezing will lead to long-term load build-up of rock support.

A comparison between squeezing and swelling phenomena by Jethwa and Dhar (1996) is given in Table 7.3. Figure 7.1 shows how radial displacements vary with time significantly within the broken zone. The radial displacement, however, tend to converge at the interface boundary of the elastic and the broken zones. Figure 7.2 shows that a compaction zone is formed within this broken zone so that the rate of tunnel wall closure is arrested.

Various approaches for estimating the ground conditions for tunnelling on the basis of Q and modified Q , i.e., rock mass number N are dealt with in the following paragraphs (Chapters 8 and 9 describe Q and N respectively in details).

7.3 Empirical Approach

7.3.1 Singh et al. (1992) Criteria

Singh et al.(1992) have suggested an empirical approach based on 39 case histories by collecting data on Barton et al. (1974) rock mass quality Q and overburden H . These cases have been plotted and a clear cut demarcation line AB has been obtained to differentiate

Prediction of ground conditions for tunnelling

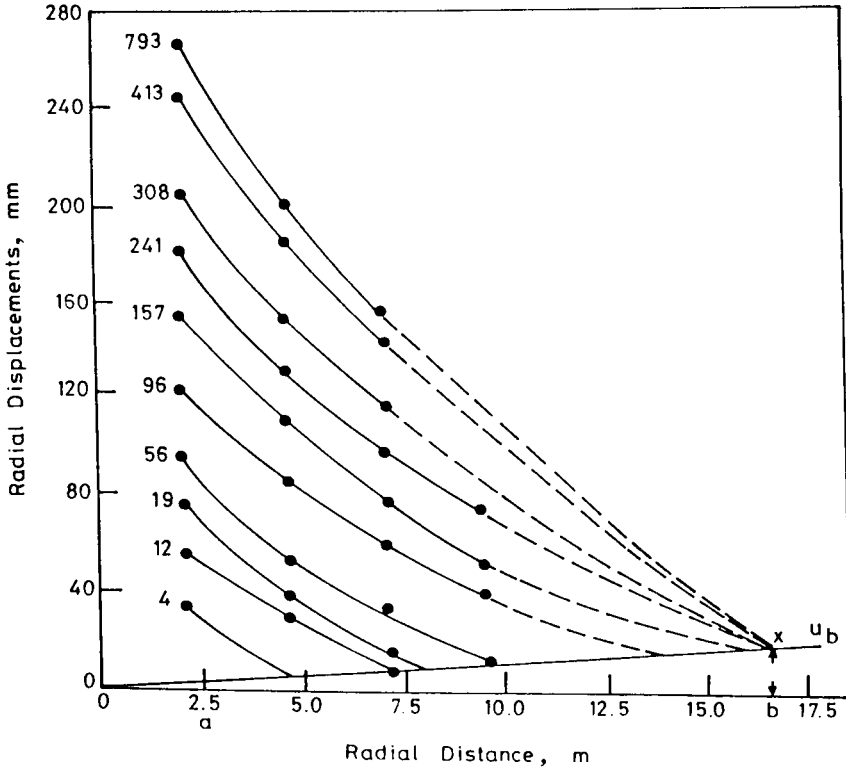

Figure 7.1: Variation of radial displacement with radial distance within slates/phyllites of Giri Tunnel, India (Jethwa, 1981)

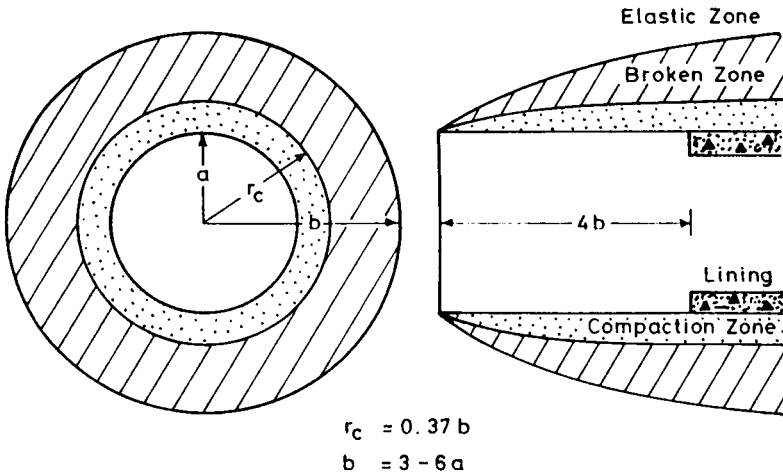

Figure 7.2: Compaction zone within broken zone in the squeezing ground condition (Jethwa, 1981)

TABLE 7.3
COMPARISON BETWEEN SQUEEZING AND SWELLING PHENOMENA
(JETHWA AND DHAR, 1996)

| Parameter | Squeezing | Swelling |
|-------------------|---|---|
| 1. Cause | Small volumetric expansion of weak and soft ground upon stress-induced shear failure Compaction zone can form within broken zone | Volumetric expansion due to ingress of moisture in ground containing highly swelling minerals |
| 2. Closure | | |
| * Rate of closure | (i) very high initial rate, several centimeters per day for the first 1 - 2 weeks of excavation (ii) Reduces with time | (i) High initial rate for first 1 - 2 weeks till moisture penetrates deep into the ground (ii) Decreases with time as moisture penetrates into the ground deeply with difficulty |
| * Period | (iii) May continue for years in exceptional case | (iii) May continue for years if the moist ground is scooped out to expose fresh ground |
| 3. Extent | The affected zone can be several tunnel diameters thick | The affected zone is several metres thick. Post-construction saturation may increase swelling zone significantly |

the squeezing cases from non- squeezing cases as shown in Figure 7.3. The equation of line AB is

$$H = 350 Q^{1/3} \quad \text{metres} \quad (7.1)$$

It implies that an squeezing ground condition would be encountered if

$$H >> 350 Q^{1/3} \quad \text{metres} \quad (7.2)$$

and a non-squeezing ground condition would be encountered if

$$H << 350 Q^{1/3} \quad \text{metres} \quad (7.3)$$

It is suggested that efforts should be made, in future, to account for the ratio of horizontal to vertical insitu stresses.

Figure 7.3: Criteria for predicting ground conditions (Singh et al., 1992)

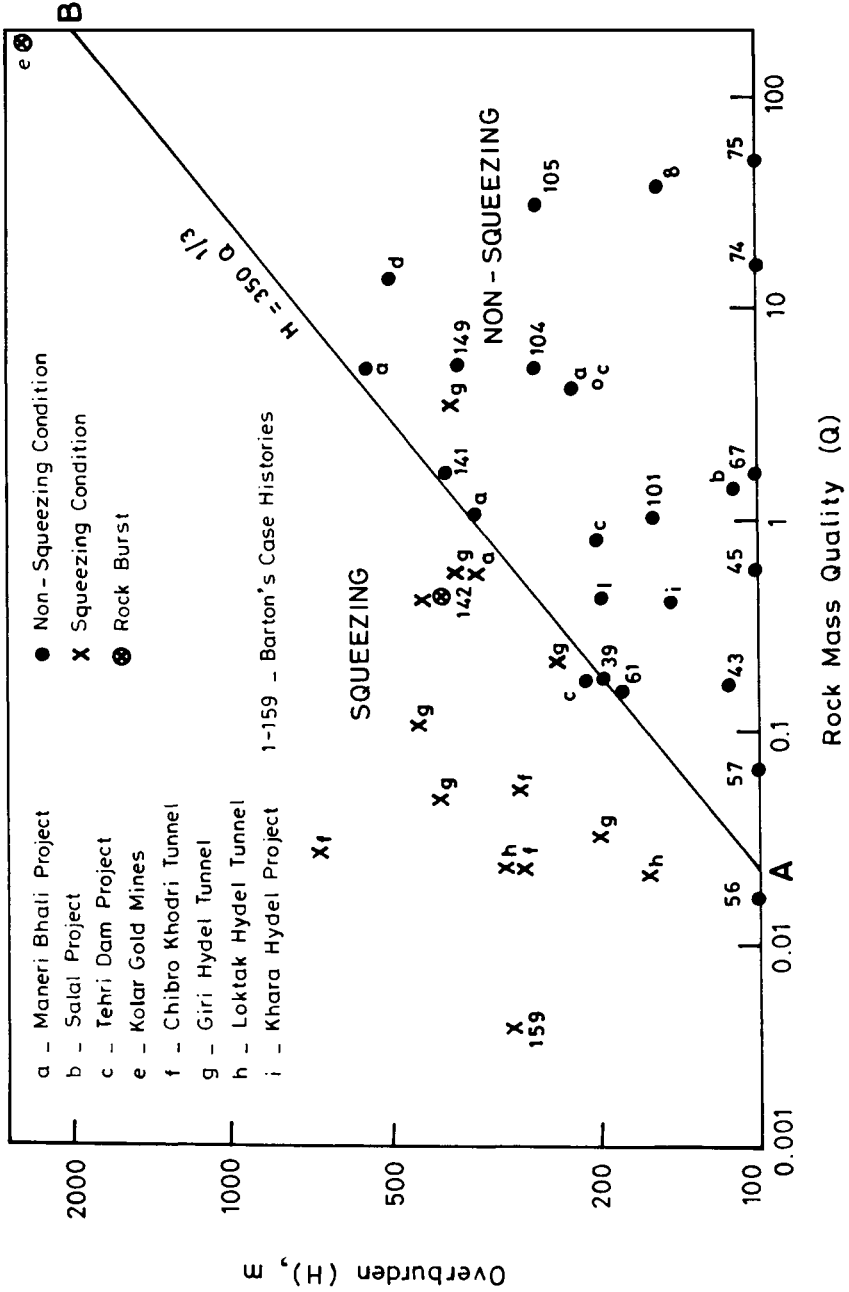

7.3.2 Criteria of Goel et al. (1995) Using Rock Mass Number N

Prediction of non-squeezing and squeezing ground conditions

To avoid the uncertainty in obtaining appropriate SRF ratings in rock mass quality Q of Barton et al. (1974), Goel et al. (1995) have suggested rock mass number N, defined as follows, for proposing the criteria of estimating ground conditions for tunnelling.

$$N = [Q]_{SRF = 1} \tag{7.4}$$

Other parameters considered are the tunnel depth H in metres to account for stress condition SRF indirectly, and tunnel width B to take care of the strength reduction of the rock mass. The values of three parameters - the rock mass number N, the tunnel depth H and the tunnel diameter or width B were collected from 99 tunnel sections covering a wide variety of ground conditions varying from highly jointed and fractured rock masses to massive rock masses. Source of these cases and the number of test- sections in different ground conditions are given in Table 7.4.

All the 99 data points were plotted on a log-log graph (Figure 7.4) between rock mass number N and $H.B^{0.1}$. In Figure 7.4, a clear line AB demarcating the squeezing and the non-squeezing cases is obtained. The equation of this line is

$$H = (275 N^{0.33}) B^{-0.1} \text{ metres} \tag{7.5}$$

where,

- H = tunnel depth or overburden in metres, and
- B = tunnel span or diameter in metres.

The points lying above the line AB (Eqn. 7.5) represent squeezing ground conditions, whereas those below this line represent the non-squeezing ground condition. This can be explained as follows.

TABLE 7.4
SOURCE OF DATA AND NUMBER OF TUNNEL SECTIONS IN DIFFERENT GROUND CONDITIONS USED FOR DEVELOPING EQN. 7.5 (GOEL, 1994)

| Ground Condition | Sub-class | No. of cases from | | |
|---------------------------------|------------------------|-------------------|-----|-----|
| | | India | NGI | UK |
| Competent (69) | Self-supporting (25) | 13 | 9 | 3 |
| | Non-squeezing (44) | 15 | 28 | 1 |
| Squeezing ground condition (29) | Mild squeezing (14) | 14 | Nil | Nil |
| | Moderate squeezing (6) | 5 | 1 | Nil |
| | High squeezing (9) | 8 | 1 | Nil |
| Rock Burst (1) | -- | 1 | | |

Prediction of ground conditions for tunnelling

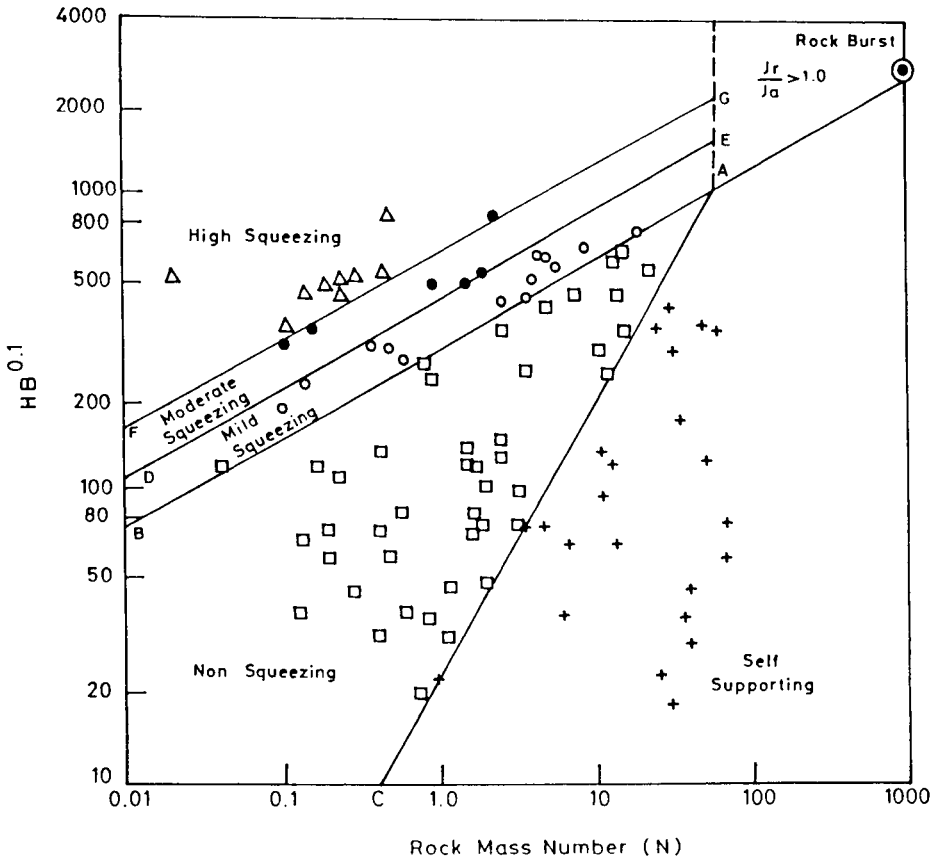

Figure 7.4: Plot between rock mass number N and $HB^{0.1}$ for predicting ground conditions (Goel, 1994)

for a squeezing ground condition

$$H \gg (275 N^{0.33}) \cdot B^{-0.1} \text{ metres} \tag{7.6}$$

and

for a non-squeezing ground condition

$$H \ll (275 N^{0.33}) \cdot B^{-0.1} \text{ metres} \tag{7.7}$$

Use of Eqn. 7.5 has been explained with the help of the following example:

Worked Example :

In a hydroelectric project in India a tunnel was driven through metabasics having rock mass number N as 20, tunnel depth H as 635m and the tunnel diameter B as 5.8m.

Using Eqn. 7.5, the calculated value of H comes out to be 620m. However, the actual depth is 635m. This satisfies the squeezing ground condition represented by inequality expression 7.6. In order to avoid the squeezing ground condition, the designers could either re-align the tunnel to reduce the cover or make it pass through a rock mass having a higher N value.

This (Eqn.7.5) also explains why the observations in a drift cannot represent the ground condition in the main tunnel because a drift would normally not experience depth as great as the main tunnel.

Prediction of self-supporting and non-squeezing ground conditions

As presented in Chapter 6, Bieniawski (1973) has neglected the effect of insitu stress/tunnel depth H while obtaining the span of unsupported or self-supporting tunnel using RMR. Barton et al. (1974) have proposed Eqn.8.11 for the unsupported span but they have not given adequate weightage to tunnel depth in SRF (Chapter 8), due to paucity of squeezing case history in their data bank.

Goel et al. (1995b) have developed an additional criterion to estimate the self-supporting tunnelling condition. In Figure 7.4, a demarcation line CA has been obtained to separate the cases representing self-supporting condition from the non-squeezing condition. The equation of this line is obtained as follows:

$$H = 23.4 N^{0.88} B_s^{-0.1} \quad \text{metres} \quad (7.8)$$

where,

B_s = unsupported span or span of self-supporting tunnel in meters.

Equation 7.8 suggests that for self-supporting tunnel condition

$$H \ll 23.4 N^{0.88} B_s^{-0.1} \quad \text{metres} \quad (7.9)$$

$$B_s = 2 Q^{0.4} \quad \text{metres (after Barton et al., 1974)} \quad (7.10)$$

Prediction of degree of squeezing

Degree of squeezing and its effect on tunnelling

It was realized that the degree of squeezing can very well be represented by tunnel closure on the lines of Singh et al. (1995) as follows.

Prediction of ground conditions for tunnelling

- (i) Mild squeezing - closure 1-3 per cent of tunnel diameter,
- (ii) Moderate squeezing - closure 3-5 per cent of tunnel diameter, and
- (iii) High squeezing - closure > 5 per cent of tunnel diameter.

On the basis of the above limits of closures, it has been noted that out of 29 squeezing cases, 14 cases denote mild squeezing, 6 cases represent moderate squeezing and 9 cases pertain to high squeezing ground conditions (Table 7.4).

It may be added here that, tangential strain ϵ_θ is equal to the ratio of tunnel closure and diameter. If it exceeds the failure strain ϵ_f of the rock mass, squeezing will occur. Moreover, mild squeezing may not begin even if closure is 1% and less than ϵ_f in most cases.

Considering the above limits of closure, it has become possible to draw two more demarcation lines DE and FG in the squeezing zone in Figure 7.4. The equation of the line DE separating cases of mild from moderate squeezing ground conditions is obtained as:

a. mild and moderate squeezing

$$H = (450 N^{0.33}) \cdot B^{-0.1} \quad \text{metres} \quad (7.11)$$

Similarly, the equation of the line FG separating the moderate and the high squeezing conditions is obtained as:

b. moderate and high squeezing

$$H = (630 N^{0.33}) \cdot B^{-0.1} \quad \text{metres} \quad (7.12)$$

TABLE 7.5
PREDICTION OF GROUND CONDITION USING N (GOEL, 1994)

| S. No. | Ground Conditions | Correlations for Predicting Ground Condition |
|--------|--------------------|--|
| 1. | Self-supporting | $H < 23.4 N^{0.88} \cdot B^{-0.1}$ & $1000 B^{-0.1}$ and $B < 2 Q^{0.4}$ m |
| 2. | Non-squeezing | $23.4 N^{0.88} \cdot B^{-0.1} < H < 275 N^{0.33} \cdot B^{-0.1}$ |
| 3. | Mild squeezing | $275 N^{0.33} \cdot B^{-0.1} < H < 450 N^{0.33} \cdot B^{-0.1}$ and $J_r/J_a < 0.5$ |
| 4. | Moderate squeezing | $450 N^{0.33} \cdot B^{-0.1} < H < 630 N^{0.33} \cdot B^{-0.1}$ and $J_r/J_a < 0.5$ |
| 5. | High squeezing | $H > 630 N^{0.33} \cdot B^{-0.1}$ and $J_r/J_a < 0.25$ |

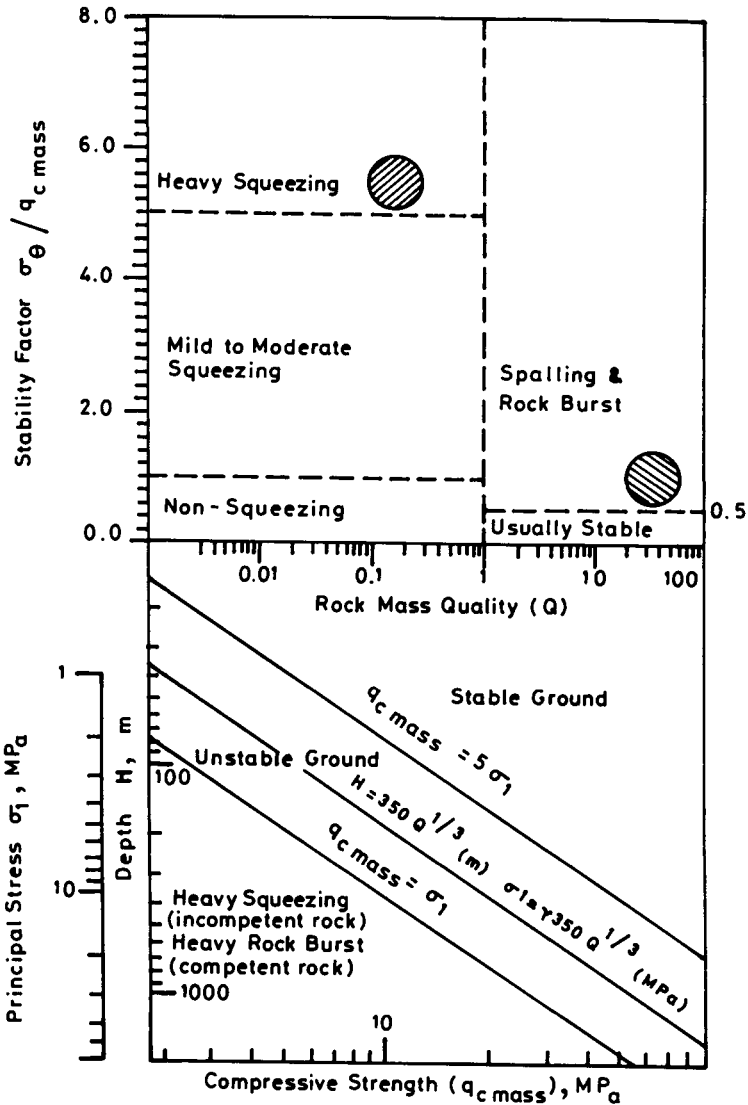

Figure 7.5: Monogram for prediction of tunnel stability (Bhasin, 1996)

All these equations for predicting ground conditions have been summarized in Table 7.5. Infact, it may be added here that squeezing ground condition has not been encountered in tunnels where J_r / J_a was found to be more than 0.5.

7.3.3 Criteria of Bhasin and Grimstad (1996)

Using the results of Eqn. 7.1, Bhasin and Grimstad (1996) developed a monogram (Figure 7.5) between rock mass strength, insitu stress and rock behaviour in tunnels with rock mass quality Q for estimating the ground conditions.

7.4 Theoretical / Analytical Approach

Theoretically, the squeezing conditions around a tunnel opening are encountered if,

$$\sigma_{\theta} > \text{strength} = q_{c\text{mass}} + P_o A/2 \quad (7.13)$$

where σ_{θ} is the tangential stress and $q_{c\text{mass}}$ is the uniaxial compressive strength of the rock mass, P_o is insitu stress along tunnel axis and A is rock parameter proportional to friction (Chapter 13). Practically, Eqn. 7.13 can be written as follows for a circular tunnel under hydrostatic stress field.

$$2 P > q_{c\text{mass}} + P \cdot A/2 \quad (7.14)$$

where P is the magnitude of the overburden pressure. It may be noted that squeezing may not occur in hard rocks with high value of parameter 'A'.

Use of Eqn. 7.14 for predicting the squeezing ground condition poses practical difficulties as the measurement of the insitu stress and determination of the insitu compressive strength of a rock mass are both time consuming and expensive.

ISRM classifies squeezing rock/ground condition as follows:

| <i>Degree of Squeezing</i> | $\sigma_{\theta}/q_{c\text{mass}}$ (ISRM) | $q_{c\text{mass}} / (\gamma \cdot H)$ (Barla, 1995) |
|----------------------------|--|--|
| No squeezing | < 1.0 | > 1.0 |
| Mild squeezing | 1.0 - 2.0 | 0.4 - 1.0 |
| Moderate squeezing | 2.0 - 4.0 | 0.2 - 0.4 |
| High squeezing | > 4.0 | < 0.2 |

The above suggested approach may be used reliably depending upon the values of σ_{θ} and $q_{c\text{mass}}$.

7.5 Effect of Thickness of Weak Band on Squeezing Ground Condition

Limited experience along 29 km long tunnel of Nathpa-Jhakri project, H. P., India suggests that squeezing does not take place if thickness of the band of a weak rock mass is less than $2.Q^{0.4}$ metres approximately. However, more project data is needed for a better correlation.

In Chapter 8, the Q-system is presented.

References

- Barla, G. (1995). Squeezing Rocks in Tunnels, *ISRM News Journal*, **Vol. 2, No. 3 & 4**, pp. 44 - 49.
- Barton, N., Lien, R., and Lunde, J. (1974). Engineering Classification of Rock Masses for the Design of Tunnel Support, *Rock Mechanics*, Springer-Verlag, **Vol. 6**, pp. 189-236.
- Bhasin, R. and Grimstad, Eystein. (1996). The Use of Stress-Strength Relationships in the Assessment of Tunnel Stability, *Proc. Recent Advances in Tunnelling Technology*, CSMRS, New Delhi, India, pp. 183-196.
- Bieniawski, Z. T. (1973). Engineering Classification of Jointed Rock Masses, *Trans. S. Afr. Instn. Civil Engrs.*, **Vol. 15**, pp. 335-342.
- Goel, R. K. (1994). Correlations for Predicting Support Pressures and Closures in Tunnels, *Ph. D. Thesis, Nagpur University*, Nagpur, India, p. 308.
- Goel, R. K., Jethwa, J. L. and Paithankar, A. G. (1995). Indian Experiences with Q and RMR Systems, *Jr. Tunnelling & Underground Space Technology*, Pergamon, **Vol. 10, No.1**, pp. 97-109.
- Goel, R. K., Jethwa, J. L. and Paithankar, A.G. (1995b). An Empirical Approach for Predicting Ground Condition for Tunnelling and its Practical Benefits, *Proc. 35th U.S. Sym. Rock Mech.*, Univ. of Nevada, Reno, USA, pp. 431-35.
- Heuer, Ronald. E. (1974). Important Ground Parameters in Soft Ground Tunnelling, Proc. Conf. Subsurface Exploration for Underground Excavation and Heavy Construction, ASCE, in Chapter 5 *Tunnel Engineering Handbook* - Ed. by John, O. Bickel and T. R. Kuessel; 1982.
- ISRM - Referred the Definitions of Squeezing received from ISRM.
- Jethwa, J. L., Singh, B., Singh, Bhawani, and Mithal, R.S. (1980). Influence of Geology on Tunnelling Conditions and Deformational Behaviour of Supports in the Faulted Zones - A Case History of Chhibro-Khodri Tunnel in India, *Engineering Geology*, Elsevier, **Vol. 16, No. 3/4**, pp. 291-318.
- Jethwa, J. L. and Dhar, B. B. (1996). Tunnelling under Squeezing Ground Condition, *Proc. Recent Advances in Tunnelling Technology*, New Delhi, pp. 209-214.
- Singh, Bhawani, Jethwa, J. L., Dube, A. K. and Singh, B. (1992). Correlation between Observed Support Pressure and Rock Mass Quality, *Jr. Tunnelling & Underground Space Technology*, Pergamon, **Vol. 7, No. 1**, pp. 59-74.
- Singh, Bhawani, Jethwa, J. L. and Dube, A. K. (1995). A Classification System for Support Pressure in Tunnels and Caverns, *Jr. Rock Mech. & Tunnelling Technology*, India, **Vol. 1, No., 1**, January, pp. 13-24.

Prediction of ground conditions for tunnelling

Singh, Bhawani, Goel, R. K., Jethwa, J.L. and Dube , A. K. (1997). Support Pressure Assessment in Arched Underground Openings through Poor Rock Masses, *Engineering Geology*, Elsevier, **Vol. 48**, pp. 59-81.

CHAPTER - 8

ROCK MASS QUALITY (Q) - SYSTEM

"Genius is 99 percent perspiration and 1 percent inspiration"
Bernard Shaw

8.1 The Q-System

Barton, Lien and Lunde (1974) at the Norwegian Geotechnical Institute (NGI) originally proposed the Q-system of rock mass classification on the basis of about 200 case histories of tunnels and caverns. They have defined the rock mass quality Q as follows:

$$Q = \left[\text{RQD}/J_n \right] \left[J_r/J_a \right] \left[J_w/\text{SRF} \right] \quad (8.1)$$

where,

- RQD = Deere's Rock Quality Designation ≥ 10 ,
- J_n = Joint set number,
- J_r = Joint roughness number for critically oriented joint set,
- J_a = Joint alteration number for critically oriented joint set,
- J_w = Joint water reduction factor, and
- SRF = Stress reduction factor.

For various rock conditions, the ratings (numerical value) to these six parameters are assigned. The six parameters given in Eqn. 8.1 are defined as below.

8.1.1 Rock Quality Designation (RQD)

RQD is discussed in Chapter 4. The RQD value in percentage is the rating of RQD for the Q-system. In case of a poor rock mass where RQD is less than 10 percent, a minimum value of 10 should be used to evaluate Q (see Table 8.1).

8.1.2 Joint Set Number (J_n)

The parameter J_n , representing the number of joint sets, is often affected by foliations, schistosity, slaty cleavages or beddings, etc. If strongly developed, these parallel discontinuities should be counted as a complete joint set. If there are few joints visible or only occasional breaks in rock core due to these features, then one should count them as "a random joint set" while evaluating J_n from Table 8.2. Rating of J_n is approximately equal to square of the number of joint sets.

8.1.3 Joint Roughness Number and Joint Alteration Number (J_r and J_a)

The parameters J_r and J_a , given in Tables 8.3 and 8.4 respectively, represent roughness and degree of alteration of joint walls or filling materials. The parameters J_r and J_a should be obtained for the weakest critical joint-set or clay-filled discontinuity in a given zone. If the joint set or the discontinuity with the minimum value of (J_r / J_a) is favourably oriented for stability, then a second less favourably oriented joint set or discontinuity may be of greater significance, and its value of (J_r / J_a) should be used when evaluating Q from Eqn. 8.1. For the effect of the joint sets Table 6.7 may be referred.

8.1.4 Joint Water Reduction Factor (J_w)

The parameter J_w (Table 8.5) is a measure of water pressure, which has an adverse effect on the shear strength of joints. This is due to reduction in the effective normal stress across joints. Water in addition may cause softening and possible wash-out in the case of clay-filled joints.

8.1.5 Stress Reduction Factor (SRF)

The parameter SRF (Table 8.6) is a measure of - (i) loosening pressure in the case of an excavation through shear zones and clay bearing rock masses, (ii) rock stress q_c / σ_1 in a competent rock mass where q_c is uniaxial compressive strength of rock material and σ_1 is the major principal stress before excavation, and (iii) squeezing or swelling pressures in incompetent rock masses. SRF can also be regarded as a total stress parameter.

Ratings of all the six parameters are given in Tables 8.1 to 8.6. The ratings of these parameters obtained for a given rock mass are substituted in Eqn. 8.1 to get rock mass quality Q.

TABLE 8.1
ROCK QUALITY DESIGNATION RQD (BARTON ET AL., 1974)

| Condition | RQD |
|--------------|----------|
| A. Very Poor | 0 - 25 |
| B. Poor | 25 - 50 |
| C. Fair | 50 - 75 |
| D. Good | 75 - 90 |
| E. Excellent | 90 - 100 |

Note: (i) Where RQD is reported or measured as ≤ 10 (including 0), a nominal value of 10 is used to evaluate Q
(ii) RQD intervals of 5, i.e., 100, 95, 90 etc. are sufficiently accurate

TABLE 8.2
JOINT SET NUMBER J_n (BARTON ET AL., 1974)

| Condition | J_n |
|---|-----------|
| A. Massive, none or few joints | 0.5 - 1.0 |
| B. One joint set | 2 |
| C. One joint set plus random | 3 |
| D. Two joint sets | 4 |
| E. Two joint sets plus random | 6 |
| F. Three joint sets | 9 |
| G. Three joint sets plus random | 12 |
| H. Four or more joint sets, random, heavily jointed, "sugar cube", etc. | 15 |
| I. Crushed rock, earth like | 20 |
| <u>Note:</u> (i) For intersections use $(3.0 \cdot J_n)$ | |
| (ii) For portals use $(2.0 \cdot J_n)$ | |

TABLE 8.3
JOINT ROUGHNESS NUMBER J_r (BARTON ET AL., 1974)

| Condition | J_r |
|--|-------|
| <i>(a) Rock wall contact and</i> | |
| <i>(b) Rock wall contact before 10cm shear</i> | |
| A. Discontinuous joint | 4 |
| B. Rough or irregular, undulating | 3 |
| C. Smooth, undulating | 2.0 |
| D. Slickensided, undulating | 1.5 |
| E. Rough or irregular, planar | 1.5 |
| F. Smooth, planar | 1.0 |
| G. Slickensided, planar | 0.5 |
| <i>(c) No rock wall contact when sheared</i> | |
| H. Zone containing clay minerals thick enough to prevent rock wall contact | 1.0 |
| I. Sandy, gravelly, or crushed zone thick enough to prevent rock wall contact | 1.0 |
| <u>Note:</u> (i) Add 1.0 if the mean spacing of the relevant joint set is greater than 3m | |
| (ii) $J_r = 0.5$ can be used for planar, slickensided joints having lineation, provided the lineations are favourably oriented | |
| (iii) Descriptions B to G above refer to small scale and intermediate scale features, in that order | |

Rock mass quality (Q) - system

TABLE 8.4
JOINT ALTERATION NUMBER J_a (BARTON ET AL., 1974)

| Condition | ϕ_r (degree) | J_a |
|--|----------------------|-------|
| <i>(a) Rock wall contact</i> | | |
| A. Tightly healed, hard, non-softening, impermeable filling, i.e., quartz or epidote | | 0.75 |
| B. Unaltered joint walls, surface staining only | 25-35 | 1.0 |
| C. Slightly altered joint walls. Non-softening mineral coatings, sandy particles, clay-free disintegrated rock, etc. | 25-30 | 2.0 |
| D. Silty or sandy clay coatings, small clay fraction (non-softening) | 20-25 | 3.0 |
| E. Softening or low-friction clay mineral coatings, i.e., kaolinite, mica. Also chlorite, talc, gypsum, and graphite, etc., and small quantities of swelling clays (discontinuous coatings, 1-2 mm or less in thickness) | 8-16 | 4.0 |
| <i>(b) Rock wall contact before 10 cm shear</i> | | |
| F. Sandy particles, clay-free disintegrated rock, etc. | 25-30 | 4.0 |
| G. Strongly over-consolidated, non-softening clay mineral fillings (continuous, <5mm in thickness) | 16-24 | 6.0 |
| H. Medium or low over-consolidation, softening, clay mineral fillings (continuous, <5mm in thickness) | 12-16 | 8.0 |
| J. Swelling clay fillings, i.e., montmorillonite (continuous, <5 mm in thickness). Value of J_a depends on percentage of swelling clay-sized particles, and access to water, etc. | 6-12 | 8-12 |
| <i>(c) No rock wall contact when sheared</i> | | |
| K. Zones or bands of disintegrated or crushed rock and clay (see G, H, J for description of clay condition) | 6-24 | 8-12 |
| L. Zones or bands of silty or sandy clay, small clay fraction (non-softening) | | 5 |
| M. Thick, continuous zones or bands of clay (see G, H, J for description of clay condition) | 6 - 24 | 13-20 |
| <u>Note:</u> (i) Values of ϕ_r are intended as an approximate guide to the mineralogical properties of the alteration products, if present. | | |

TABLE 8.5
JOINT WATER REDUCTION FACTOR J_w (BARTON ET AL., 1974)

| Condition | App. Water pressure, MPa | J_w |
|--|---|----------|
| A. Dry excavations or minor inflow, i.e., 5 lt./min locally | <0.1 | 1 |
| B. Medium inflow or pressure occasional out-wash of joint fillings | 0.1-0.25 | 0.66 |
| C. Large inflow or high pressure in competent rock with unfilled joints | 0.25-1.0 | 0.5 |
| D. Large inflow or high pressure, considerable out-wash of joint fillings | 0.25-1.0 | 0.33 |
| E. Exceptionally high inflow or water pressure at blasting, decaying with time | >1.0 | 0.2-0.1 |
| F. Exceptionally high inflow or water pressure continuing without noticeable decay | >1.0 | 0.1-0.05 |
| Note: (i) | Factors C to F are crude estimates. Increase J_w if drainage measures are installed | |
| (ii) | Special problems caused by ice formation are not considered | |

TABLE 8.6
STRESS REDUCTION FACTOR SRF (BARTON ET AL., 1974 AND GRIMSTAD AND BARTON, 1993)

| Condition | SRF |
|---|------|
| (a) <i>Weakness zones intersecting excavation, which may cause loosening of rock mass when tunnel is excavated</i> | |
| A. Multiple occurrences of weakness zones containing clay or chemically disintegrated rock, very loose surrounding rock (any depth) | 10.0 |
| B. Single-weakness zones containing clay or chemically disintegrated rock (depth of excavation $\leq 50\text{m}$) | 5.0 |
| C. Single-weakness zones containing clay or chemically disintegrated rock (depth of excavation $> 50\text{m}$) | 2.5 |
| D. Multiple-shear zones in competent rock (clay-free), loose surrounding rock (any depth) | 7.5 |
| E. Single-shear zones in competent rock (clay-free) (depth of excavation $\leq 50\text{m}$) | 5.0 |

Rock mass quality (Q) - system

TABLE 8.6 (Continued)

| | | | | | |
|--|--|----------------|----------------|-----------|-----------|
| F. | Single-shear zones in competent rock (clay-free) (depth of excavation >50m) | | | | 2.5 |
| G. | Loose open joints, heavily jointed or "sugar cube", etc. (any depth) | | | | 5.0 |
| <i>(b) Competent rock, rock stress problems</i> | | | | | |
| | | q_c/σ_1 | q_t/σ_1 | SRF (old) | SRF (New) |
| H. | Low stress, near surface open joints | >200 | <0.01 | 2.5 | 2.5 |
| J. | Medium stress, favourable stress condition | 200-10 | 0.01-0.3 | 1 | 1.0 |
| K. | High stress, very tight structure (usually favourable to stability, may be unfavourable to wall stability) | 10-5 | 0.3-0.4 | 0.5-2 | 0.5-2.0 |
| L. | Moderate slabbing after >1 hr in massive rock | 5-3 | 0.5-0.65 | 5-9 | 5-50 |
| M. | Slabbing and rock burst after a few minutes in massive rock | 3-2 | 0.65-1.0 | 9-15 | 50-200 |
| N. | Heavy rock burst (strain- burst) and immediate deformations in massive rock | <2 | >1 | 15-20 | 200-400 |
| <i>(c) Squeezing rock; plastic flow of incompetent rock under the influence of high rock pressures</i> | | | | | |
| O. | Mild squeezing rock pressure | | | | 5-10 |
| P. | Heavy squeezing rock pressure | | | | 10-20 |
| <i>(d) Swelling rock; chemical swelling activity depending on presence of water</i> | | | | | |
| Q. | Mild swelling rock pressure | | | | 5-10 |
| R. | Heavy swelling rock pressure | | | | 10-15 |
| <u>Note:</u> | (i) Reduce these SRF values by 25-50% if the relevant shear zones only influence but do not intersect the excavation | | | | |
| | (ii) For strongly anisotropic stress field (if measured): when $5 \leq \sigma_1/\sigma_3 \leq 10$, reduce q_c and q_t to $0.8 q_c$ and $0.8 q_t$; when $\sigma_1/\sigma_3 > 10$, reduce q_c and q_t to $0.6 q_c$ and $0.6 q_t$ (where q_c is unconfined compressive strength, q_t is tensile strength (point load), σ_1 and σ_3 are major and minor principal stress) | | | | |
| | (iii) Few case records available where depth of crown below surface is less than span width. Suggest SRF increase from 2.5 to 5 for such cases (see H) | | | | |
| | (iv) For getting the rating of SRF in case of squeezing ground condition, the degree of squeezing can be obtained using Table 7.5, Chapter 7 | | | | |

TABLE 8.7
ESTIMATION OF ANGLE OF INTERNAL FRICTION FROM THE PARAMETERS
 J_r AND J_a (BARTON ET AL., 1974)

| Description | J_r | $\tan^{-1}(J_r / J_a)$ | | | | |
|---------------------------------------|-------|------------------------|------|------|------|------|
| | | $J_a = 0.75$ | 1.0 | 2.0 | 3.0 | 4.0 |
| (a) Rock wall contact | | $J_a = 0.75$ | 1.0 | 2.0 | 3.0 | 4.0 |
| A. Discontinuous joints | 4.0 | 79° | 76° | 63° | 53° | 45° |
| B. Rough, undulating | 3.0 | 70° | 72° | 56° | 45° | 37° |
| C. Smooth, undulating | 2.0 | 69° | 63° | 45° | 34° | 27° |
| D. Slickensided, undulating | 1.5 | 63° | 56° | 37° | 27° | 21° |
| E. Rough, planar | 1.5 | 63° | 56° | 37° | 27° | 21° |
| F. Slickensided, planar | 0.5 | 34° | 27° | 14° | 9.5° | 7.1° |
| (b) Rock wall contact when sheared | J_r | $J_a = 4.0$ | 6 | 8 | 12 | |
| A. Discontinuous joints | 4.0 | 45° | 34° | 27° | 18° | |
| B. Rough, undulating | 3.0 | 37° | 27° | 21° | 14° | |
| C. Smooth, undulating | 2.0 | 27° | 18° | 14° | 9.5° | |
| D. Slickensided, undulating | 1.5 | 21° | 14° | 11° | 7.1° | |
| E. Rough, planar | 1.5 | 2.1° | 14° | 11° | 7.1° | |
| F. Slickensided, planar | 0.5 | 7° | 4.7° | 3.6° | 2.4° | |
| (c) No rock wall contact when sheared | J_r | $J_a = 6$ | 8 | 12 | | |
| Disintegrated or crushed rock or clay | 1.0 | 9.5° | 7.1° | 4.7° | | |
| Bands of silty or sandy clay | J_r | $J_a = 5$ | | | | |
| | 1.0 | 11° | | | | |
| | J_r | $J_a = 10$ | 13 | 20 | | |
| Thick continuous bands of clay | 1.0 | 5.7° | 4.4° | 2.9° | | |

As seen from Eqn. 8.1, the rock mass quality (Q) may be considered a function of only three parameters which are approximate measures of :

- a. Block size (RQD / J_n) : It represents overall structure of rock mass
- b. Inter block shear strength (J_r / J_a) : It has been found that $\tan^{-1}(J_r / J_a)$ is a fair approximation to the actual peak sliding angle of friction along the clay coated joints (Table 8.7)
- c. Active stress (J_w / SRF) : It is an empirical factor describing the active stress

The first quotient (RQD / J_n) represents the rock mass structure and is a measure of block size or the size of the wedge formed by the presence of different joint sets. In a given rock mass, the rating of parameter J_n could increase with the tunnel size in certain situations where

additional joint sets are encountered. Hence it is not advisable to use Q-value obtained from a small drift to estimate the support pressure for a large tunnel or a cavern. It would be more appropriate to obtain J_n from drill core observations or a borehole camera.

The second quotient (J_r / J_a) represents the roughness and frictional characteristics of joint walls or filling materials. It should be noted that value of J_r / J_a is collected for the critical joint set, i.e., the joint set which is most unfavourable for stability of a key rock block.

The third quotient (J_w / SRF) is an empirical factor describing "active stress condition". The stress reduction factor SRF, is a measure of: (i) loosening pressure in the case of an excavation through shear zones and clay bearing rocks, (ii) rock stress in competent rocks and (iii) squeezing pressure in plastic incompetent rocks; and can be regarded as a total stress parameter. The water reduction factor J_w is a measure of water pressure, which has an adverse effect on the shear strength of joints due to reduction in effective normal stress. Water, in addition, causes softening and possible outwash in the case of clay filled joints. In the hydroelectric projects where rock masses get charged with water after commissioning of projects, J_w should be reduced accordingly on the basis of judgement, while using Q for estimating the final support requirements.

8.2 The Joint Orientation and the Q-system

Commenting on the joint orientation, Barton et al. (1974) stated that it was not found to be an important parameter as expected. Part of the reason for this may be that the orientation of many types of excavation can be, and normally are, adjusted to avoid the maximum effect of unfavourably oriented major joints. Barton et al. (1974) also stated that the parameters J_n , J_r and J_a appear to play a more important role than the joint orientation, because the number of joint sets determines the degree of freedom for block movement (if any), and the frictional and dilatational characteristics (J_r) can vary more than the down-dip gravitational component of unfavourably oriented joints. If joint orientation had been included, the classification system would be less general, and its essential simplicity lost. Table 6.9 also suggests that the joint orientation is least important in tunnels than in foundations and slopes.

8.3 Updating of the Q-system

Updating of the 1974 Q - system has taken place on several occasions during the last few years, and is now based on 1,050 case records where the installed rock support has been correlated to the observed Q -values. The original parameters of the Q-system have not been changed, but some of the ratings for the stress reduction factor SRF have been altered by Grimstad and Barton (1993). The new ratings of SRF for competent rocks are also shown in Table 8.6. This was done because a hard massive rock under high stress requires far more support than those recommended by the Q-value with SRF (old) ratings. In the original 1974 Q-system, this problem was addressed in a supplementary note instructing how to support spalling or rock burst zones with closely spaced end-anchored rock bolts and triangular steel

plates. Recent experience from tunnels under high stresses in hard rocks suggests less bolting, but extensive use of steel fibre reinforced shotcrete (SFRS), an unknown product when the Q-system was first developed in 1974. The up-dating of the Q-system has shown that in the most extreme case of high stress and hard massive (unjointed) rock, the maximum SRF value has to be increased from 20 to 400 in order to give a Q-value which correlates with the modern rock supports shown in Figure 8.4.

Authors' experience suggests that overburden height H should be considered in addition to SRF (old) in Table 8.6 for obtaining the ratings of squeezing ground conditions.

8.4 Collection of Field Data

The length of core or rock exposures to be used for evaluating the first four parameters (RQD , J_n , J_r , and J_a) would depend on the uniformity of the rock mass. If there is little variation, a core or wall length of 5-10m should be sufficient. However, in a few meters wide closely jointed shear zone with alternate sound rock, it will be necessary to evaluate these parameters separately if it is considered that the closely jointed shear zones are wide enough to justify special treatment (i.e. additional shotcrete) compared to only systematic bolting in the remainder of the excavation. If, on the other hand, the shear zones are less than 1/2 metres and occur frequently, then an overall reduced value of Q for the entire tunnel reach may be most appropriate since increased support is likely to be applied uniformly along the entire length of such variable zones. In such cases a core or wall length of 10-50 m may be needed to obtain an overall picture of the reduced rock mass quality (Chapter 2).

Notes

1. Values of the rock mass quality Q be obtained separately for the roof, the floor and the two walls, particularly when the geological description of the rock mass is not uniform around the periphery of an underground opening.
2. In case of power tunnels, it is suggested that the value of J_w for calculation of ultimate support pressures should be reduced assuming that seepage water pressure in Table 8.5 is equal to the internal water pressure after commissioning the hydroelectric projects.

8.4.1 Suggestions for Beginners

Beginners may find difficulty in selecting a single rating for a particular parameter. They may opt for a range of rating or two ratings or values for tension free judgement. Subsequently, a geometrical mean should be obtained from the minimum and the maximum values for obtaining a representative value of the parameter. This will not only reduce the bias but would also generate confidence among the users.

It is proposed that for the purpose of eliminating the bias of an individual's mind, the rating for different parameters should be given a range in preference to a single value.

To overcome the problem of selecting a representative rating of various parameters, NGI has proposed a geotechnical chart (Figure 8.1). The main body of the geotechnical chart consists of rectangular graduated areas for making numerous individual observations of joints and jointing characteristics, in the form of a histogram. They proposed that efforts should be made to estimate approximate percentages of the various qualities of each observed parameter, i.e., 10% poorest, 60% most typical, 30% best or maximum value, since the weighted average from all the histograms masks the extreme values. For example: the values of Q parameters collected at a location are shown in the following Table 8.8.

TABLE 8.8
WEIGHTED AVERAGE METHOD OF OBTAINING Q VALUE (BARTON, 1993)

| Parameter of Q | Poorest Value (10 %) | Most Typical Value (60 %) | Maximum Value (30 %) | Weighted Average |
|----------------|----------------------|---------------------------|----------------------|------------------|
| RQD | 25 | 65 | 85 | 67 |
| J_n | 12 | 9 | - | 9.42 |
| J_r | 1.5 | 3 | 4 | 2.05 |
| J_a | 4 | 2 | 1 | 1.9 |
| J_w | 0.66 | 1 | 1 | 0.966 |
| SRF | 7.5 | 5 | 2.5 | 4.5 |

Using the weighted average value of each parameter, one can obtain a more realistic Q from Eqn. 8.1. The weighted average value has been obtained using the percentage weightage mentioned above and as shown for RQD below.

A weighted average for RQD in above Table 8.8 is obtained as

$$(1 \times 25 + 6 \times 65 + 3 \times 85) / 10 = 67$$

Similarly, weighted averages can be obtained for other parameters like Joint wall Compressive Strength (JCS), Joint wall Roughness Coefficient (JCS), etc. as proposed by NGI.

8.5 Classification of the Rock Mass

The rock mass quality Q is a very sensitive index and its value varies from 0.001 to 1000. Use of the Q - system is specifically recommended for tunnels and caverns with arched roof. On the basis of the Q-value, the rock masses have been classified into nine categories (Table 8.9).

8.6 Estimation of Support Pressure

8.6.1 Using Approach of Barton et al. (1974)

Barton et al. (1974, 1975) plotted support capacities of 200 underground openings against the rock mass quality (Q) as shown in Figure 8.2. They found the following empirical correlation for ultimate support pressure:

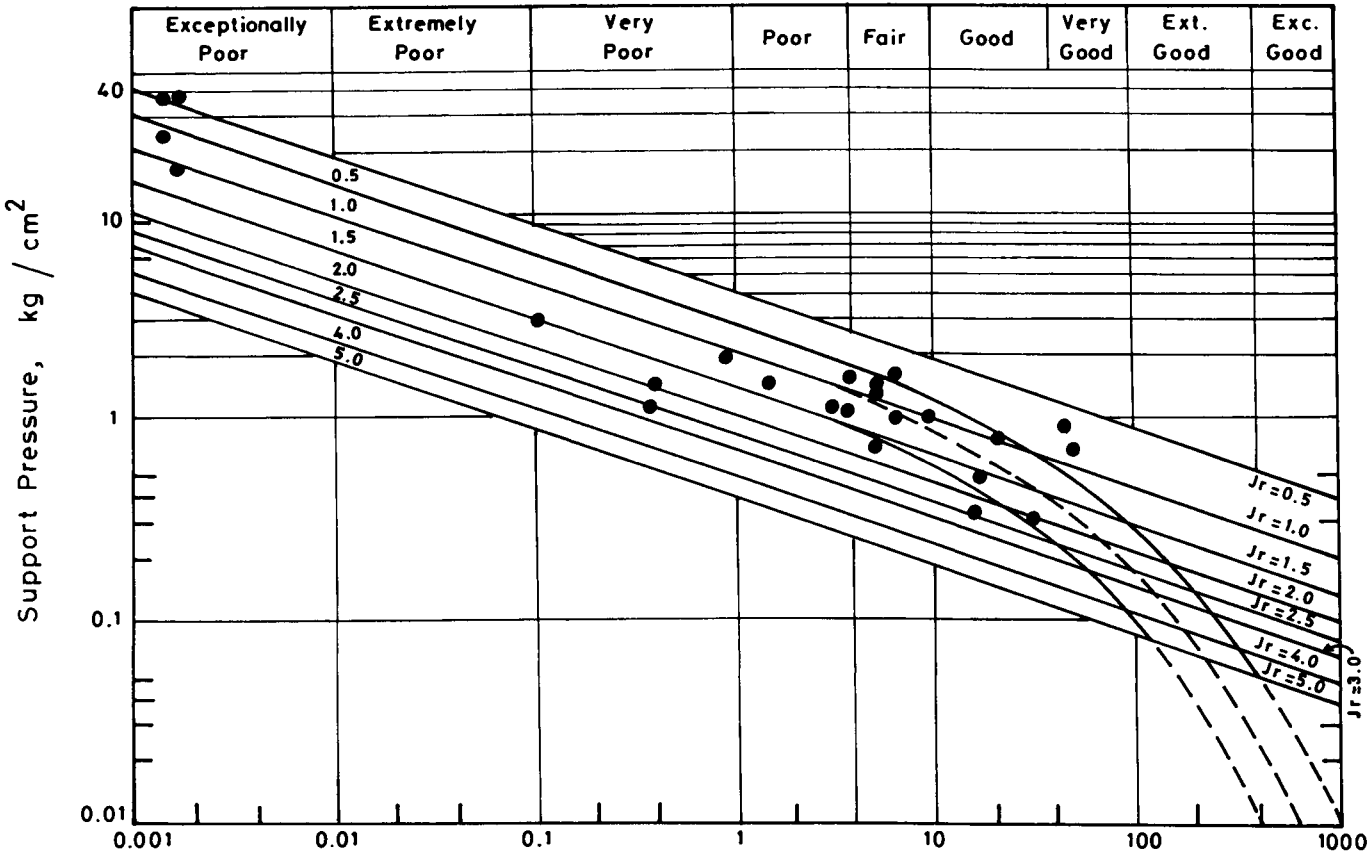

Figure 8.2: Correlation between support pressure and rock mass quality Q (Barton et al., 1974)

$$\text{Rock Mass Quality, } Q = \left(\frac{RQD}{J_n} \right) \times \left(\frac{J_r}{J_a} \right) \times \left(\frac{J_w}{SRF} \right)$$

TABLE 8.9
CLASSIFICATION OF ROCK MASS BASED ON Q- VALUES

| Q | Group | Classification |
|-----------------|-------|--------------------|
| 010.000-0040.00 | 1 | Good |
| 040.000-0100.00 | | Very good |
| 100.000-0400.00 | | Extremely good |
| 400.000-1000.00 | | Exceptionally good |
| 000.100-0001.00 | 2 | Very poor |
| 001.000-0004.00 | | Poor |
| 004.000-0010.00 | | Fair |
| 000.001-0000.01 | 3 | Exceptionally poor |
| 000.010-0000.10 | | Extremely poor |

$$p_v = (0.2/J_r) Q^{-1.3} \quad (8.2)$$

$$p_h = (0.2/J_r) Q_w^{-1.3} \quad (8.3)$$

where,

- p_v = ultimate roof support pressure in MPa,
- p_h = ultimate wall support pressure in MPa, and
- Q_w = wall factor.

It may be noted that dilatant joints or J_r values play a dominant role in the stability of underground openings. Consequently, support capacities may be independent of the opening size as believed by Terzaghi (1946).

The wall factor (Q_w) is obtained after multiplying Q by a factor which depends on the magnitude of Q as given below :

| Range of Q | Wall Factor Q_w |
|------------|-------------------|
| > 10 | 5.0 Q |
| 0.1 - 10 | 2.5 Q |
| < 0.1 | 1.0 Q |

Barton et al. (1974) further suggested that if the number of joint sets is less than three, Eqns. 8.2 and 8.3 are expressed as Eqns. 8.4a and 8.4b, respectively.

$$p_v = \frac{0.2 \cdot J_n^{1.2}}{3 \cdot J_r} \cdot Q^{-1.3} \quad (8.4a)$$

$$p_h = \frac{0.2 \cdot J_n^{1.2}}{3 \cdot J_l} \cdot Q_w^{-1.3} \quad (8.4b)$$

Rock mass quality (Q) - system

They felt that the short-term support pressure can be obtained after substituting $5Q$ in place of Q in Eqn 8.2. Thus, the ultimate support pressure is obtained as 1.7 times the short-term support pressure.

Bhasin and Grimstad (1996) suggested the following correlation for predicting support pressure in tunnels through poor rock masses (say $Q < 4$):

$$p_v = \frac{40 B}{J_r} \cdot Q^{-1.3} \quad \text{kPa} \quad (8.5)$$

where B is diameter or span of the tunnel in metres.

Equation 8.5 shows that the support pressure increases with tunnel size B in poor rock masses.

8.6.2 Correlation by Singh et al. (1992)

It may be mentioned that Q referred to in the above correlations is actually the post - excavation quality of a rock mass, because, in tunnels the geology of the rock mass is usually studied after blasting and on the spot decision is taken on support density.

a. Short-term support pressure

Vertical or roof support pressure

The observed roof support pressure is related to the short-term rock mass quality (Q_i) for 30 instrumented tunnels by the following empirical correlation

$$p_v = \frac{0.2}{J_r} \cdot Q_i^{1/3} \cdot f \cdot f' \cdot f'' \quad \text{MPa} \quad (8.6)$$

$$f = 1 + (H - 320) / 800 \geq 1 \quad (8.7)$$

where,

- Q_i = $5Q$ = short-term rock mass quality,
- p_v = short-term roof support pressure in MPa,
- f = correction factor for overburden (Figure 8.3),
- f' = correction factor for tunnel closure (Table 8.10) obtained from Figure 8.4,
= 1 in non- squeezing,
- f'' = correction factor for the time after excavation (Eqn. 8.9), and
- H = overburden above crown or tunnel depth below ground level in metres.

While developing Eqn. 8.6, the correction factors have been applied in steps. Firstly, the correction factor for tunnel depth has been applied, afterwards the correction for tunnel closure and finally the correction for time after support erection (Singh et al., 1992).

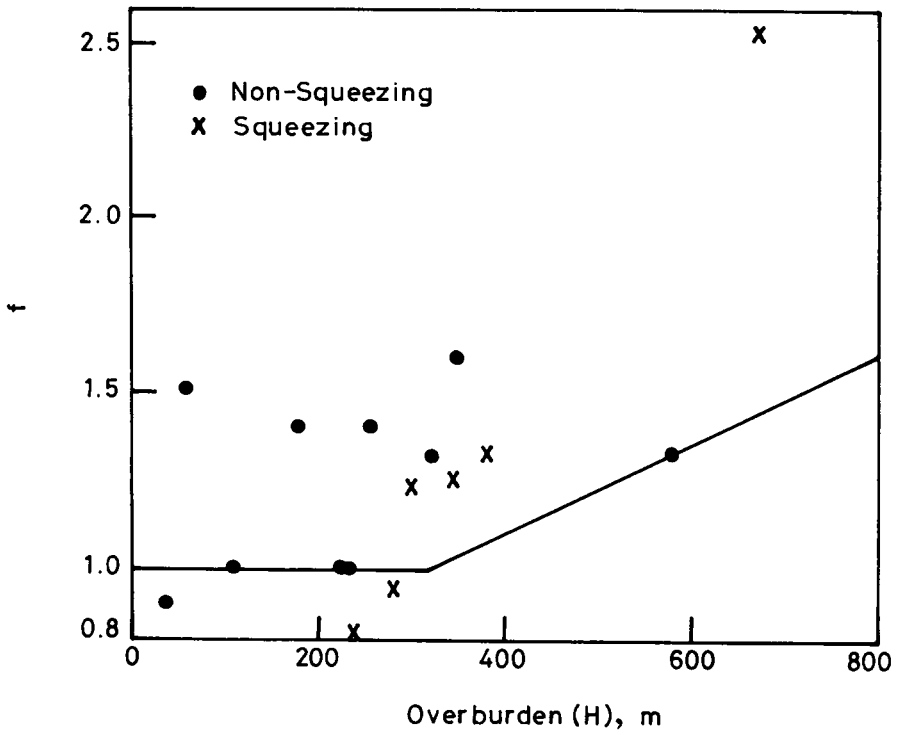

Figure 8.3: Correction factor f' for tunnel depth or overburden (Singh et al., 1992)

Values of correction factors for tunnel closure (f') can be obtained from Table 8.10 on the basis of design value of tunnel closure. Table 8.10 has been derived from Figures 8.4a and 8.4b between normalised tunnel closure (u_d/a) and the correction factor for tunnel closure f' defined in Eqn. 8.6. It may be noted that Figures 8.4a and 8.4b represent normalised observed ground response (reaction) curves for tunnel roof and walls respectively in squeezing ground.

The correction factor f'' for time was found as

$$f'' = \log(9.5 t^{0.25}) \quad (8.9)$$

where t is time in months after support installation.

Incorporating the above three correction factors, Singh et al. (1992) proposed the following correlation for ultimate tunnel support pressure p_{ult} :

$$p_{ult} = \frac{0.2}{J_r} \cdot Q_i^{-1.3} \cdot f \cdot f' \cdot f'' \text{ MPa} \quad (8.10)$$

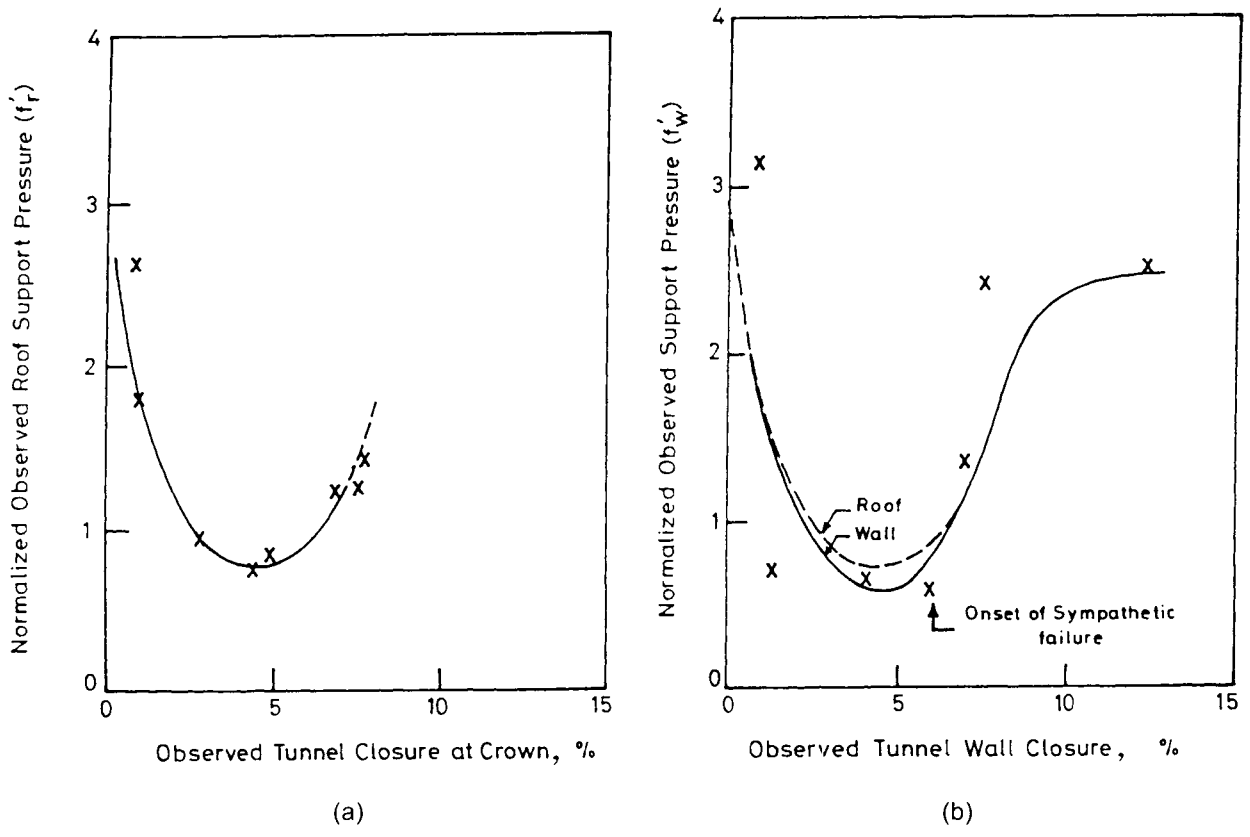

Figure 8.4 : Correction factor for (a) roof closure and (b) wall closure under squeezing ground condition (Singh et al., 1992)

TABLE 8.10
CORRECTION FACTOR f' FOR TUNNEL CLOSURE (SINGH ET AL., 1992)

| S.No. | Rock Condition | Support System | Tunnel Closure (u_a/a), % | Correction factor, f' |
|-------|--------------------------------------|--------------------|-------------------------------|-------------------------|
| 1. | Non-squeezing ($H < 350 Q^{0.33}$) | - | <1 | 1.1 |
| 2. | Squeezing ($H > 350 Q^{0.33}$) | Very stiff | <2% | >1.8 |
| 3. | -do- | Stiff | 2 - 4% | 0.85 |
| 4. | -do- | Flexible | 4 - 6% | 0.70 |
| 5. | -do- | Very flexible | 6 - 8% | 1.15 |
| 6. | -do- | Extremely flexible | > 8% | 1.8 |

Note:

1. Tunnel closure depends significantly on method of excavation. In highly squeezing ground conditions, heading and benching method may lead to tunnel closure > 8%.
2. Tunnel closures more than 4% of tunnel span should not be allowed, otherwise support pressures are likely to build-up rapidly due to failure rock arch. In such cases, additional rock anchors should be installed immediately to arrest the tunnel closure within a limiting value.
3. Steel ribs with struts may not absorb more than 2% tunnel closure. Thus, slotted SFRS is suggested as an immediate support at the face to be supplemented with steel arches behind the face in situations where excessive closures are encountered.

Singh et al. (1992) have also studied the effect of tunnel size (2m - 22m) on support pressures. They inferred no significant effect of size on observed support pressure.

Horizontal or wall support pressure

For estimating wall support pressure. Eqn. 8.10 may be used with short-term wall rock mass quality Q_{wi} in place of Q_i .

The short-term wall rock quality Q_{wi} for short-term wall support pressure is obtained after multiplying Q_i by a factor which depends on the magnitude of Q as given below:

- (i) For $Q > 10$; $Q_{wi} = 5.0 Q_i = 25 Q$,
- (ii) For $0.1 < Q < 10$; $Q_{wi} = 2.5 Q_i = 12.5 Q$, and
- (iii) For $Q < 0.1$; $Q_{wi} = 1.0 Q_i = 5 Q$

Rock mass quality (Q) - system

The observed short-term wall support pressure is insignificant generally in non-squeezing rock conditions. It is, therefore, recommended that these may be neglected in the case of tunnels in rock masses of good quality of group 1 in Table 8.9 ($Q > 10$).

Note: Although the wall support pressure would be negligible in non-squeezing ground conditions, high wall support is common in poor grounds or squeezing ground conditions. Therefore, invert struts with steel ribs be used when the estimated wall support pressure requires the use of wall support in exceptionally poor rock conditions and highly squeezing ground conditions. NATM or NTM are better choice otherwise.

b. Ultimate support pressure

Long-term monitoring at Chhibro cavern of Yamuna hydroelectric Project in India has enabled the researchers to study the support pressure trend with time and with saturation. The study on the basis of 10 years monitoring has shown that the ultimate support pressure for water charged rock masses with erodible joint fillings may raise upto 6 times the short-term support pressure (Mitra, 1990). The monitoring also suggested that for tunnels located near faults / thrusts (with plastic gouge) in seismic areas, the ultimate support pressure might be about 25 per cent more due to accumulated strains in the rock mass along the fault.

On extrapolating the support pressure values for 100 years, a study of Singh et al. (1992) has shown that the ultimate support pressure would be about 1.75 times the short-term support pressure under non-squeezing ground conditions, whereas in squeezing ground condition, Jethwa (1981) has estimated that the ultimate support pressure would be 2 to 3 times the short-term support pressure.

8.6.3 Evaluation of the Approach of Barton et al. & Singh et al.

Support pressures estimated from Eqns. 8.4a and 8.4b for various test- sections have been compared with the measured values. The estimates are reasonable (correlation coefficient $r = 0.81$) for tunnel sections through non-squeezing ground conditions. In squeezing ground conditions, the estimated support pressures never exceeded 0.7 MPa, whereas the measured values were as high as 1.2 MPa for larger tunnels. Therefore, it is thought that the Q-system may be unsafe for larger tunnels (diameter > 9 m) under highly squeezing ground conditions (Goel et al., 1995).

The estimated support pressures from Eqn. 8.10 are also compared with the measured values for non-squeezing and squeezing ground conditions. It has been found out that the correlation of Singh et al. (1992) provides reasonable estimates of support pressures.

Limitations of the Q-system

Kaiser et al. (1986) opined that SRF is probably the most contentious parameter. He concluded that it may be appropriate to neglect the SRF during rock mass classification and to

assess the detrimental effects of high stresses separately. However, he has not given any alternate approach to assess high stress effect. Keeping this problem in mind, Goel et al. (1995) have proposed rock mass number N, i.e., stress-free Q and incorporated stress-effect in the form of tunnel depth H to suggest a new set of empirical correlations for estimating support pressures. This aspect has been discussed in Chapter 9.

8.7 Unsupported Span

Barton et al. (1974) proposed the following equation for estimating equivalent dimension (D_e') of a self supporting or an unsupported tunnel

$$D_e' = 2.0 (Q^{0.4}) \quad \text{metres} \quad (8.11)$$

if $H < 350 Q^{1/3}$ metres

where,

D_e' = equivalent dimension
 = $\frac{\text{span, diameter or height in metres}}{\text{ESR}}$,

Q = rock mass quality and
 ESR = excavation support ratio.

TABLE 8.11
 VALUES OF EXCAVATION SUPPORT RATIO ESR (BARTON ET AL., 1974)

| S. No. | Type of Excavation | ESR |
|--------|--|----------------|
| 1 | Temporary mine openings, etc. | 3 - 5 ? |
| 2 | Vertical shafts: (i) circular section (ii) rectangular / square section | 2.5 ? 2.0 ? |
| 3 | Permanent mine openings, water tunnels for hydro power (excluding high pressure penstocks), pilot tunnels, drifts and headings for large excavations, etc. | 1.6 |
| 4 | Storage rooms, water treatment plants, minor road and railway tunnels, surge chambers, access tunnels, etc. | 1.3 |
| 5 | Oil storage caverns, power stations, major road and railway tunnels, civil defence chambers, portals, intersections, etc. | 1.0 |
| 6 | Underground nuclear power stations, railway stations, sports and public facilities, factories, etc. | 0.8 ? |

Rock mass quality (Q) - system

In equivalent dimension, the span or diameter is used for analysing the roof support, and the height of wall in case of wall support.

Excavation support ratio (ESR) appropriate to a variety of underground excavations is listed below (Table 8.11).

General requirements for permanently unsupported openings are,

(a) $J_n < 9, J_r > 1.0, J_a < 1.0, J_w = 1.0, \text{SRF} < 2.5$

Further, conditional requirements for permanently unsupported openings are given below.

- (b) If $\text{RQD} < 40$, need $J_n < 2$
- (c) If $J_n = 9$, need $J_r > 1.5$ and $\text{RQD} > 90$
- (d) If $J_r = 1.0$, need $J_w < 4$
- (e) If $\text{SRF} > 1$, need $J_r > 1.5$
- (f) If span > 10 m, need $J_n < 9$
- (g) If span > 20 m, need $J_n < 4$ and $\text{SRF} < 1$

8.8 Design of Supports

The Q value is related to tunnel support requirements with the equivalent dimensions of the excavation. The relationship between Q and the equivalent dimension of an excavation determines the appropriate support measures as depicted in Figure 8.5. Barton et al. (1974) have identified 38 support categories (Figure 8.5) and specified permanent supports for these categories. The bolt length l , which is not specified in the support details, can be determined in terms of excavation width B in metres using Eqn. 8.12 proposed by Barton et al. (1974).

$$l = 2 + (0.15 B / \text{ESR}) , \quad \text{m} \quad (8.12)$$

Since the early 1980s, wet mix steel fibre reinforced shotcrete (SFERS) together with rock bolts have been the main components of a permanent rock support in underground openings in Norway. Based on the experience, Grimstad and Barton (1993) suggested a different support design chart using the steel fibre reinforced shotcrete (SFERS) as shown in Figure 8.6. This chart is recommended for tunnelling in poor rock conditions.

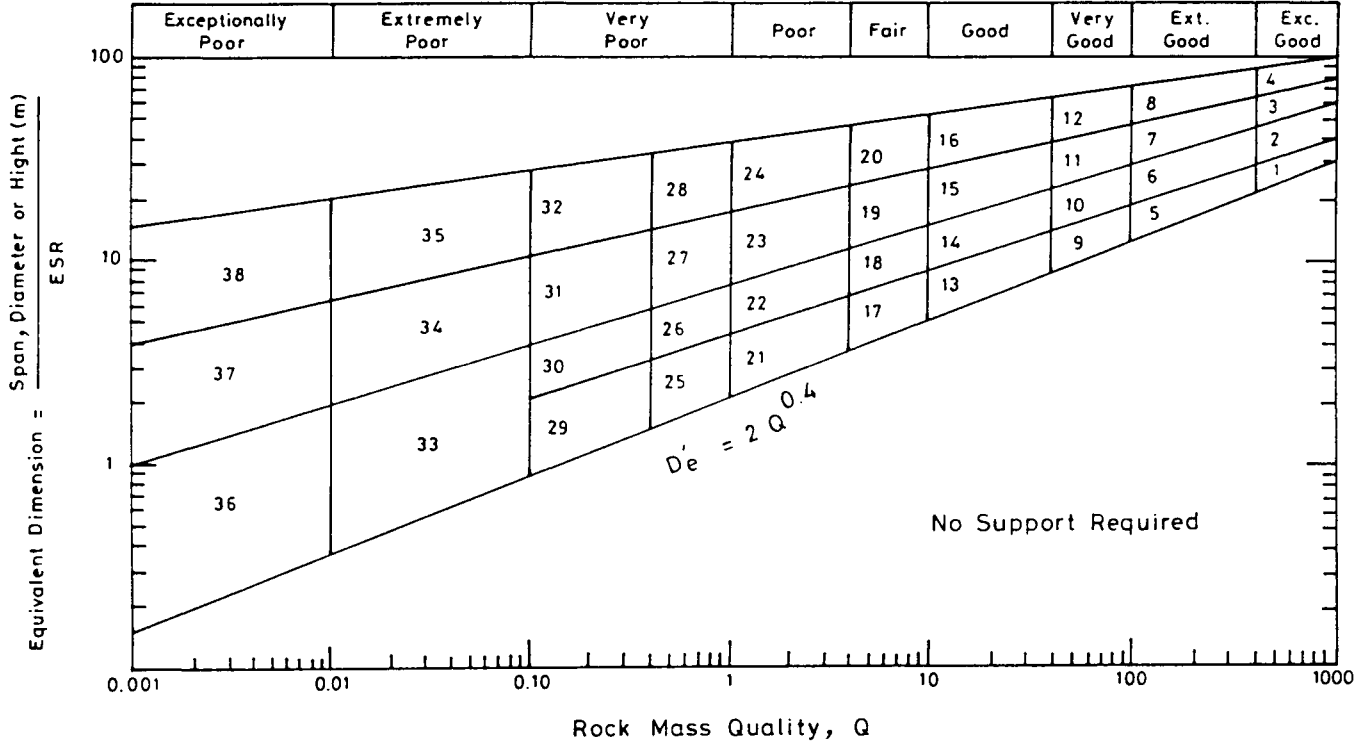

Figure 8.5 : Tunnel support chart showing 38 support categories (Barton et al., 1974)

Rock Mass Classification: A Practical Approach in Civil Engineering

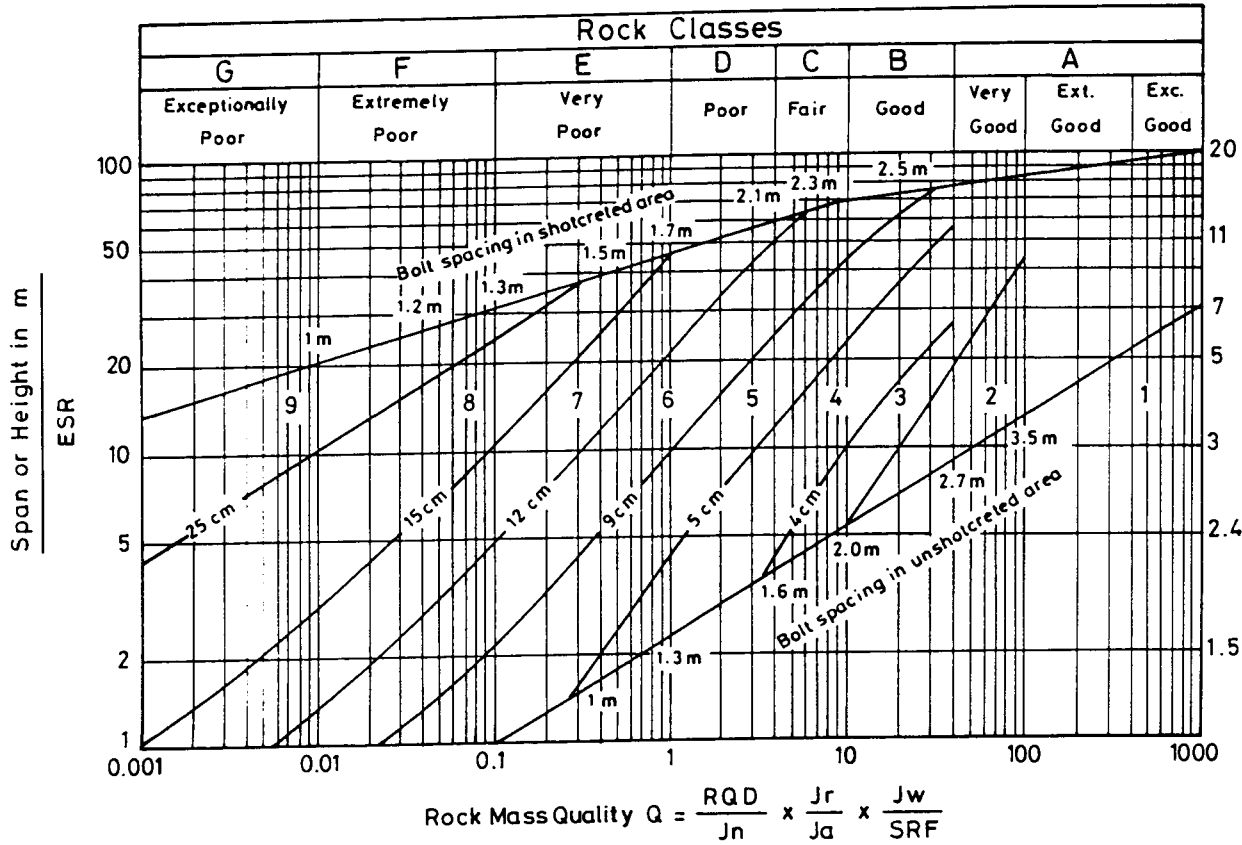

Figure 8.6 : Chart for the design of steel fibre reinforced shotcrete (SFRS) support (Grimstad and Barton, 1993)

Bolt Length in m for ESR = 1

8.9 New Austrian Tunnelling Method (NATM)

The name New Austrian Tunnelling Method (NATM) is a misnomer as it is not a method of tunnelling but a strategy for tunnelling which does have a considerable uniformity and sequence.

The NATM is based on the philosophy of "*Build as you go*" approach with the following caution.

*"Not too stiff, Nor too flexible
Not too early, Nor too late"*

The NATM accomplishes tunnel stabilization by controlled stress release. The surrounding rock is thereby transformed from a complex load system to a self-supporting structure together with the installed support elements, provided that the detrimental loosening, resulting in a substantial loss of strength, is avoided. The self stabilisation by controlled stress release is achieved by the introduction of the so called "Semi-Rigid Lining", i.e., systematic rock bolting with the application of a shotcrete lining. On one side, this offers a certain degree of immediate support, and the flexibility to allow stress release through radial deformation on the other hand. The development of shear stresses in shotcrete lining in arched roof is thus reduced to a minimum.

- (a) NATM is based on the principle that utmost advantage of the capacity of the rock mass should be taken to support itself by carefully controlling the forces in the re-distribution process which takes place in the surrounding rock mass when a cavity is made. This is also called "tunnelling with rock support". The main feature is that the rock mass in the immediate vicinity of the tunnel excavation is made to act as a load bearing member, together with the supporting system. The outer rock mass ring is activated by means of systematic rock bolting together with shotcrete. The main carrying member of the NATM is not only the shotcrete but also the systematically anchored rock arch.
- (b) The installation of systematic rock bolting with shotcrete lining allows limited deformations but prevents loosening of the rock mass. In the initial stage it requires very small forces to prevent rock mass from moving in, but once movement has started, large forces are required. Therefore, NATM advocates installation of supports within stand-up time to prevent movements. Where deformation rates are large, slotted shotcrete lining, i.e., shotcrete sprayed in longitudinal sections separated by expansion joints helps the problem. It is also added that in non-squeezing ground conditions, the stresses in the shotcrete may be reduced significantly if the spray of the shotcrete is slightly delayed. The delay, however, should be within the stand-up time. But a safe practice is spraying a sealing shotcrete layer.
- (c) In static consideration a tunnel should be treated as a thick wall tube, consisting of a bearing ring of rock arch and supporting lining. Since a tube can act as a tube only if it is closed, the closing of the ring becomes of paramount importance, specially where

Rock mass quality (Q) - system

the foundation rock is not capable of withstanding high support pressure in squeezing ground condition (see Table 7.2 serial number 6).

- (d) Due to stress - redistributions when a cavity is being excavated, a full face heading is considered most favourable. Drivage in different stages complicates the stress-redistribution phenomenon and destroys the rock mass. In cases where full face tunnelling is not possible, as in Chhibro-Khodri Tunnel and many more tunnels of India due to very little stand-up time and the associated chances of rock falls and cavities, engineers had to change to heading and benching method and struggled to achieve the targeted drivage rates in the absence of the beneficial effect of the shotcrete support.
- (e) The question arises how to use the capacity of a rock to support itself. This is accomplished by providing an initial shotcrete layer followed by systematic rock bolting, spraying additional shotcrete and using steel rib, if necessary. As in the case of the Loktak Tunnel, NATM without steel arches in high squeezing grounds would have required several layers of shotcrete which could not be accommodated without compromising with the available finished bore. The spacing of steel arches is adjusted to suite the squeezing ground condition. The behaviour of the protective support and the surrounding rock during the stress re-distribution process has to be monitored and controlled, if necessary, by different measurements.
- (f) Shotcrete in a water charged rock mass should be applied in small patches leaving gaps for effective drainage.

Thus, the basic principles of NATM are summarized as

- i. Mobilisation rock mass strength,
- ii. Shotcrete protection to preserve the load-carrying capacity of the rock mass,
- iii. Monitoring the deformation of the excavated rock mass,
- iv. Providing flexible but active supports, and
- v. Closing of invert to form a load-bearing support ring to control deformation of the rock mass,

The New Austrian Tunnelling Method (NATM) appears most suitable for soft ground which can be machine or manually excavated, where jointing and overbreak are not dominant, where a smooth profile can often be formed by smooth blasting and where a complete load bearing ring can (and often should) be established. Monitoring plays a significant role in deciding the timing and the extent of secondary support.

Despite the comments by an experienced NATM pioneer that "it is not usually necessary to provide support in hard rocks", Norwegian tunnels require more than 50,000 m³ of fibre reinforced shotcrete and more than 100,000 rock bolts each year (An article in World Tunnelling, June 1992). Two major tunnelling nations, Norway and Austria, have in fact long traditions in using shotcrete and rock bolts for tunnel supports, yet there are significant differences in philosophy and areas of application for NATM and NMT (Norwegian Method of Tunnelling).

TABLE 8.12
ESSENTIAL FEATURES OF NMT (WORLD TUNNELLING, 1992)

| S.No. | Features |
|-------|--|
| 1. | Areas of usual application |
| | jointed rock, harder end of scale ($q_c = 3$ to 300 MPa) Clay bearing zones, stress slabbing ($Q - 0.001$ to 10) |
| 2. | Usual methods of excavation |
| | Drill and blast hard rock, TBM, hand excavation in clay zones |
| 3. | Temporary support and permanent support may be any of the following |
| | CCA, S(fr)+RRS+B, B+S(fr), B+S, B, S(fr), S, sb, (NONE) * temporary support forms part of permanent support * mesh reinforcement not used * dry process shotcrete not used * steel sets or lattice girder not used, RRS used in clay zones * contractor chooses temporary support * owner/consultant chooses permanent support * final concrete lining are less frequently used, i.e., B+S(fr) is usually the final support |
| 4. | Rock mass characterisation for |
| | * predicting rock mass quality |
| | * predicting support needs |
| | * updating of both during tunnelling (monitoring in critical cases only) |
| 5. | The NMT gives low costs and |
| | * rapid advance rates in drill and blast tunnels |
| | * improved safety |
| | * improved environment |

NOTATIONS: CCA = cast concrete arches; S(fr) = steel fibre reinforced shotcrete; RRS = reinforced steel ribs in shotcrete; B = systematic bolting; S = conventional shotcrete; sb = spot bolting; NONE = no support needed

8.10 Norwegian Method of Tunnelling (NMT)

NMT appears most suitable for good rock masses even where jointing and overbreak are dominant, and where drill and blasting method or hard rock TBM's are the most usual methods of excavation. Bolting is the dominant form of rock support since it mobilise the strength of the surrounding rock mass in the best possible way. Potentially unstable rock masses with clay-filled joints and discontinuities would increasingly need shotcrete and steel fibre reinforced shotcrete SFRS [S(fr)] to supplement systematic bolting (B). It is understood in NMT that [B+S(fr)] are the two most versatile tunnel support methods, yet devised and used extensively, because they can be applied to any profile as temporary or as a permanent

support, just by changing thickness and bolt spacing. A thick load bearing ring (reinforced rib in shotcrete = RRS) can be formed as needed, and matches an uneven profile better than lattice girders or steel sets. These support requirements based on the Q - system are shown in Figure 8.6. The essential features of the NMT are summarised in Table 8.12 (World Tunnelling, 1992).

8.11 Other Applications of the Q - System

8.11.1 Modulus of Deformation of Rock Mass

Hoek and Brown (1980) suggested the use of both the Q-system and the RMR system in a joint assessment of deformation modulus, using Eqn. 6.2 and Eq. 6.7. This procedure has been followed by Barton (1993) in Figure 8.7 with one important addition. The filled circles are RMR-values related to mean values of deformation modulus, while the open squares are Q-values related to the range of modulus values.

Modulus of deformation varies considerably and a range from $10 \log Q$ to $40 \log Q$ should be expected. It is more in the horizontal direction than in the vertical direction. However, a mean value of deformation modulus can be obtained by using the following relation for $Q > 1$ (Barton et al., 1980).

$$E_{\text{mean}} = 25 \log Q \quad \text{GPa} \quad (8.13)$$

This relation gives good agreement with measured deformations when used in numerical analysis (Barton et al., 1992).

Analysis of data collected from 35 instrumented tunnels CMRI, has given the following correlation for modulus of deformation (E_d) of weak and nearly dry rock masses with coefficient of correlation as 0.85 (Singh, 1997).

$$E_d = H^{0.2} \cdot Q^{0.36} \quad \text{GPa} \quad (8.14)$$

where H is overburden above tunnel in metres $> 50\text{m}$.

It is thus seen that the deformation modulus of weak rock masses is pressure dependent. This correlation is suggested for static analysis of underground openings and concret dams. Further, the test data of 30 uniaxial jacking tests suggested the following correlation for elastic modulus E_e during unloading cycle (Singh, 1997).

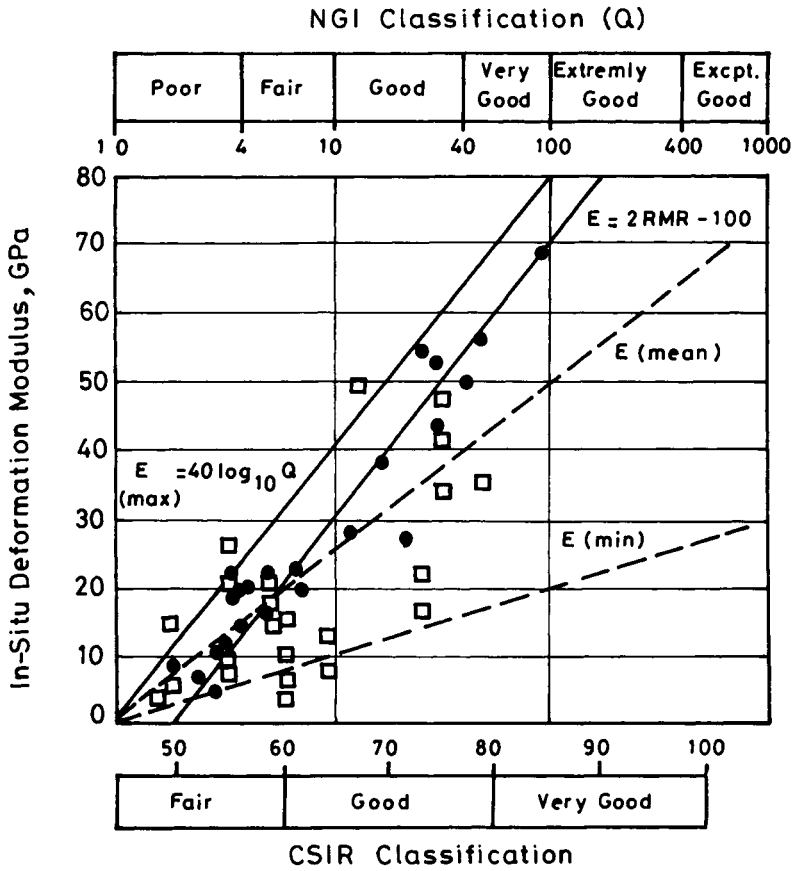

Figure 8.7: Estimation of rock mass deformation modulus from two classification methods (Barton, 1993)

$$E_c = 1.5 Q^{0.6} E_r^{0.14} \text{ GPa} \quad (8.15)$$

where,

E_r = modulus of elasticity of rock material in GPa.

Equation 8.15 is valid for both dry and saturated rock masses. It is suggested for dynamic analysis of concrete dams subjected to impulsive seismic loads due to high intensity earthquake at a nearby epicentre (active fault).

Rock mass quality (Q) - system

8.11.2 Anisotropy of Rock

Jointed rock masses have very low shear moduli due to very low shear stiffness of joints. The shear modulus of a jointed rock mass has been back analysed by Singh (1973) as follows.

$$G \approx E_d / 10 \quad \text{GPa} \quad (8.16)$$

The axis of anisotropy are naturally along the weakest joint or a bedding plane. Low shear modulus changes stress distribution drastically in the foundations as shown in Figure 19.1. Kumar (1988) studied its effect on lined tunnels and found it to be significant.

8.11.3 Q vs P-Wave Velocity

A correlation between seismic P - wave velocity and rock mass quality Q has been proposed by Barton, 1991 on the basis of around 2,000 measurements for a rough estimation of Q ahead of the tunnel face using seismic P-wave velocity,

$$Q = 10^{[(V_p - 3500)/1000]} \quad (8.17)$$

where V_p is P-wave velocity in metres per second.

For good and fair quality of granites and gneisses, an even better fit is obtained using the relation $Q = (V_p - 3600)/50$ (Barton, 1991). Table 8.13 gives the approximate values of these parameters.

TABLE 8.13
APPROXIMATE CORRELATION BETWEEN Q AND P-WAVE
VELOCITY (WORLD TUNNELLING, 1992)

| | | | | | | | |
|---------------|-------|------|------|------|------|------|------|
| V_p (m/sec) | 500 | 1500 | 2500 | 3500 | 4500 | 5500 | 6500 |
| Q | 0.001 | 0.01 | 0.1 | 1 | 10 | 100 | 1000 |

The advantage of this correlation is that cross hole seismic tomography may be used in more direct and accurate manner for specifying expected rock qualities and potential rock support needs in tender documents.

References

Barton, N. (1991). Geotechnical Design, *World Tunnelling*, Nov. 1991, pp. 410-416.

- Barton, N. (1993). Application of Q-System and Index Tests to Estimate Shear Strength and Deformability of Rock Masses, *Workshop on Norwegian Method of Tunnelling*, New Delhi, India, pp. 66-84.
- Barton, N., Lien, R., and Lunde, J. (1974). Engineering Classification of Rock Masses for the Design of Tunnel Support, *Rock Mechanics*, Springer-Verlag, **Vol. 6**, pp. 189-236.
- Barton, N., Lien, R., and Lunde, J. (1975). Estimation of Support Requirements for Underground Excavations, *XVIIth Sym. on Rock Mechanics*, University of Minnesota, Minneapolis, USA, pp. 163-177.
- Barton, N., Loset, F., Lien, R. and Lunde, J. (1980). Application of Q-system in Design Decisions Concerning Dimensions and Appropriate Support for Underground Installations, *Subsurface Space*, Pergamon, pp. 553 - 561.
- Barton, N., By, T.L., Chryssanthakis, P., Tunbridge, L., Kristiansen, J., Loset, F., Bhasin, R.K., westerdahl, H. and Vik, G. (1992). Comparison of Prediction and Performance for a 62m Span Sports Hall in Jointed Gneiss, *4th Int. Rock Mechanics and Rock Engineering Conf.*, Torino, Italy, Ed. G. Barla, pp. 17.1-17.15.
- Bhasin, R. and Grimstad, E. (1996). The Use of Stress-Strength Relationships in the Assessment of Tunnel Stability, *Proc. Conf. on Recent Advances on Tunnelling Technology*, New Delhi, **Vol. 1**, pp. 183-196.
- Dhawan, A.K. and Joshi, A.B. (1982). The Basic Approach to New Austrian Tunnelling Method, *Symposium on Tunnelling, 52nd Board Session*, CBIP, **Publication No. 159, Vol. I**, New Delhi, pp. 1 -34.
- Goel, R.K., Jethwa, J. L. and Paithankar, A. G. (1995). Indian Experiences with Q and RMR Systems, *Tunnelling & Underground Space Technology*, Elsevier Science, **Vol. 10, No.1**, pp. 97-109.
- Grimstad, E. and Barton, N. (1993). Updating of the Q-system for NMT, *Int. Symposium on Sprayed Concrete - Modern use of wet mix sprayed concrete for underground support*, Fagernes, (Editors Kompen, Opsahl and Berg. Norwegian Concrete Association, Oslo).
- Hoek, E. and Brown, E.T. (1980). *Underground Excavations in Rock*, Institution of Mining & Metallurgy, London.
- Kaiser, P.K., Mackay, C. and Gale, A. D. (1986). Evaluation of Rock Classification at B. C. Rail Tumbler Ridge Tunnels, *Rock Mechanics and Rock Engineering*, Springer-Verlag, **19**, pp. 205-234.
- Kumar, Prabhat. (1988). Development and Application of Infinite Elements for Analysis of Openings in Rock Mass, *Ph.D. Thesis, University of Roorkee*, India, p.192.
- Malhotra, R. K., Tyagi, G. D. and Sharma, Kultar. S. (1982). NATM for Tunnel Boring at Loktak H.E. Project, *Symp. on Tunnelling, 52nd Board Session*, CBIP, **Publication No. 159, Vol. I**, New Delhi, pp. 1 -34.
- Mitra, S. (1991). Studies on Long-term Behaviour of Underground Powerhouse Cavities in Soft Rocks, *Ph. D. Thesis, University of Roorkee*, India.
- Singh, Bhawani. (1973). Continuum Characterization of Jointed Rock Mass, Part II Significance of Low Shear Modulus, *Int. Jr. Rock Mech. and Min. Sci. & Geomec. Abstr.*, Pergamon, **Vol. 10**, pp. 337-349.
- Singh, Bhawani, Jethwa, J.L., Dube, A.K. and Singh, B. (1992). Correlation Between Observed Support Pressure and Rock Mass Quality, *Int. Jr.l Tunnelling & Underground Space Technology*, Pergamon, **Vol. 7, No. 1**, pp. 59-74.

Rock mass quality (Q) - system

- Singh, Suneel. (1997). Time Dependent Deformation Modulus of Rocks in Tunnels, *M.E. Thesis, Dept. of Civil Engineering, University of Roorkee, India*, p. 65.
- World Tunnelling. (1992). Focus on Norway "Norwegian Method of Tunnelling", June Issue in *Proc. Workshop on Norwegian Method of Tunnelling*, September, New Delhi, India.

CHAPTER - 9

ROCK MASS NUMBER

"My attention is now entirely concentrated on Rock Mechanics, where my experience in applied soil mechanics can render useful services. I am more and more amazed about the blind optimism with which the younger generation invades this field, without paying any attention to the inevitable uncertainties in the data on which their theoretical reasoning is based and without making serious attempts to evaluate the resulting errors"

Annual Summary in Terzaghi's Diary

9.1 Introduction

One of the reasons why rock mass classifications has become popular over the years, is that these are easy to use and at the same time provide vital information about the stability etc. Despite their usefulness, one cannot deny the uncertainty in getting correct ratings of a few parameters. How to manage these uncertainties? With this objective, two rock mass indices - rock mass number N and rock condition rating RCR have been adopted. These indices are the modified versions of the two most popular classification systems, N from the Q-system of Barton et al. (1974) and RCR from the RMR-system of Bieniawski (1973).

Rock Mass Number, denoted by N, is stress-free rock mass quality Q. Stress - effect has been considered indirectly in form of overburden height H. Thus, N can be defined by the following equation.

$$N = [RQD/J_n] [J_r/J_a] [J_w] \quad (9.1)$$

This is needed because of the problems and uncertainties in obtaining the correct rating of Barton's SRF parameter (Kaiser et al., 1986 & Goel et al., 1995a).

Rock condition Rating is defined as RMR without ratings for the crushing strength of the intact rock material and the adjustment of joint orientation. This is explained below,

$$RCR = RMR - (\text{Rating for crushing strength} + \text{Adjustment of Joint Orientation}) \quad (9.2)$$

RCR, therefore, is free from the crushing strength which is a parameter some times difficult to obtain at the site. Moreover, parameter wise, N and RCR have become equivalent and can be used for the purpose of inter-relation.

9.2 Inter-relation Between Q and RMR

Inter-relations between the two most widely used classification indices, the rock mass rating RMR of Bieniawski (1973) and the rock mass quality Q of Barton et al. (1974), have been proposed by many researchers. Bieniawski (1989) used 117 case histories involving 68 Scandinavian, 28 South African and 21 other documented case histories from the United States covering the entire range of Q and RMR to propose the following correlation (also presented in Chapter 6).

$$\text{RMR} = 9 \ln Q + 44 \quad (9.3)$$

Based on case histories from New Zealand, Rutledge and Preston (1978) proposed a different correlation as

$$\text{RMR} = 5.9 \ln Q + 43 \quad (9.4)$$

Moreno (1980), Cameron - Clarke and Budavari (1981) and Abad et al. (1984) have also proposed different correlations between Q and RMR as presented in Eqns. 9.5, 9.6 and 9.7 respectively.

$$\text{RMR} = 5.4 \ln Q + 55.2 \quad (9.5)$$

$$\text{RMR} = 5 \ln Q + 60.8 \quad (9.6)$$

$$\text{RMR} = 10.5 \ln Q + 41.8 \quad (9.7)$$

Evaluation of all the correlations, given in Eqns. 9.3 through 9.7, on the basis of 115 case histories including 77 reported by Bieniawski (1984), 4 from Kielder Experimental tunnel reported by Hoek and Brown (1980) and 34 collected from India, has indicated that the correlation coefficients of these approaches are not very reliable with the correlation of Rutledge and Preston (1978) providing the highest correlation coefficient of 0.81 followed by Bieniawski (1984), Abad et al. (1984), Moreno (1980) and Cameron-Clarke and Budavari (1981) in decreasing order as shown in Figure 9.1 and Table 9.1. These correlations, therefore, do not have high reliability for an inter-relation between Q and RMR.

TABLE 9.1
EVALUATION OF VARIOUS CORRELATIONS BETWEEN RMR AND Q
(GOEL ET AL., 1995b)

| Lines in Figure 9.1 | Approach | Correlation Coefficient |
|---------------------|----------------------------------|-------------------------|
| A | Bieniawski (1984) | 0.77 |
| B | Rutledge & Preston (1978) | 0.81 |
| C | Moreno (1980) | 0.55 |
| D | Cameron-Clarke & Budavari (1981) | High Scatter |
| E | Abad et al. (1984) | 0.66 |

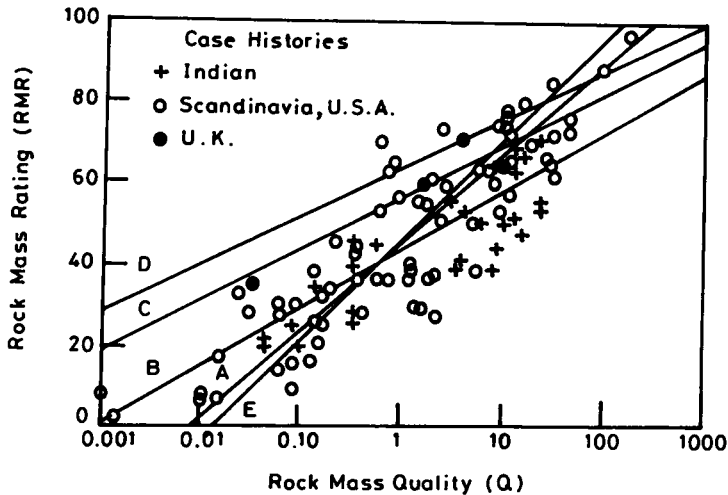

Figure 9.1: Correlations between RMR and Q (Goel et al., 1995b)

9.2.1 The New Approach

Attempts to correlate Q and RMR in Eqns. 9.3 through 9.7 ignore the fact that the two systems are not truly equivalent. It seems, therefore, that a good correlation can be developed if N and RCR are considered.

Rock condition rating RCR and rock mass number N from 63 cases were used to obtain a new inter-relation. The 63 cases consisted of 36 from India, 4 from Kielder experimental tunnel (reported by Hoek & Brown, 1980) and 23 NGI cases from Bieniawski (1984). Details about the six parameters for Q and information about joint orientation vis-a-vis tunnel axis in respect of these 23 NGI cases were picked up directly from Barton et al. (1974). Estimates of uniaxial crushing strength q_c of rock material were made from rock descriptions given by Barton et al. (1974) using strength data for comparable rock types from Lama and Vutukuri (1978). Using the ratings for joint orientation and q_c , so obtained, and RMR from Bieniawski (1984), it was possible to estimate values of RCR. Thus, the values of N and RCR for the 63 case histories were plotted in Figure 9.2 and the following correlation is obtained:

$$RCR = 8 \ln N + 30 \quad (9.8)$$

Equation 9.8 has a correlation coefficient of 0.92.

The following example explains how Eqn. 9.8 could be used to obtain RMR from Q and vice-versa.

Rock mass number

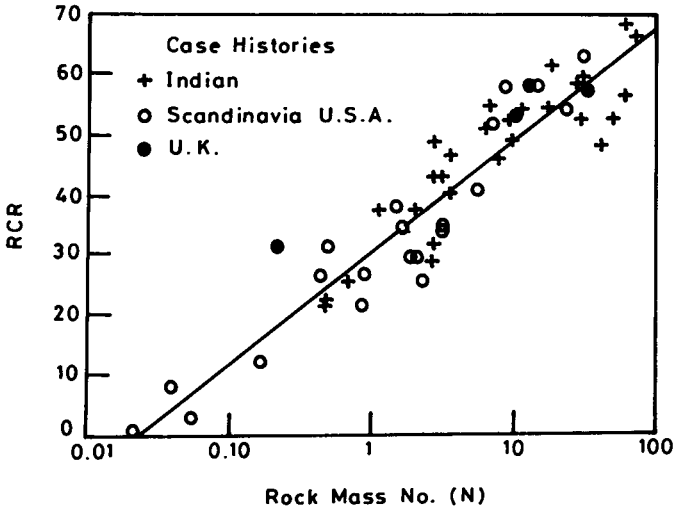

Figure 9.2: Correlation between RCR and N (Goel et al., 1995b)

Example: In Table 9.2 the values of the parameters of RMR and Q collected in the field are given

TABLE 9.2

| RMR - SYSTEM | | Q - SYSTEM | |
|-------------------------|-----------|------------------|--------------|
| Parameters for RMR | Rating | Parameters for Q | Rating |
| RQD (80 %) | 17 | RQD | 80 |
| Joint spacing | 10 | J_n | 9 |
| Joint condition | 20 | J_r | 3 |
| | | J_a | 1 |
| Ground water | 10 | J_w | 1 |
| RCR = | 57 | N = | 26.66 |
| Crushing strength q_c | +4 | SRF | 2.5 |
| Joint orientation | (-)12 | -- | -- |
| RMR = | 49 | Q = | 10.6 |

(a) RMR from Q

$N = (RQD J_r J_w) / (J_n J_a) = 26.66$ as shown in Table 9.2

Corresponding to $N = 26.66$, $RCR = 56.26$ (Eqn. 9.8)

$RMR = RCR + (\text{ratings for } q_c \text{ and joint orientation})$ - as per Eqn. 9.2

$RMR = 56.26 + [4 + (-) 12]$

RMR = 48.26 (It is comparable to RMR 49 obtained from direct estimation as shown in Table 9.2)

(b) Q from RMR

RCR = RMR - (ratings for q_c and joint orientation) as per Eqn. 9.2

$$\text{RCR} = 49 - (4 - 12)$$

$$\text{RCR} = 57$$

Corresponding to RCR = 57, N = 29.22 (Eqn. 9.8)

$$Q = (N / \text{SRF}) = 29.22 / 2.5$$

Q = 11.68 (almost equal to the field estimated value, Table 9.2)

The slight difference in directly estimated values of Q and RMR and those obtained by the proposed inter-relation are due to the inherent scatter in Eqn. 9.8.

9.3 Prediction of Ground Conditions

All the correlations for predicting ground conditions have been discussed in Chapter 7.

9.4 Prediction of Support Pressure

These correlations are based on measured support pressures and other related parameters from several Indian tunnels having steel rib support. Detailed field studies have been carried out for eight tunnelling projects located in the Himalaya and the peninsular India.

Two sets of empirical correlations for estimating support pressure for tunnel sections under non-squeezing and squeezing ground conditions have been developed using N and the measured values of support pressures, the tunnel depth H, the tunnel radius a and the expected tunnel closure u_a from 25 tunnel sections (Goel et al., 1995a). The correlations are as follows:

Non-squeezing ground condition

$$p_v(\text{el}) = \left[\frac{0.12 H^{0.1} \cdot a^{0.1}}{N^{0.33}} \right] - 0.038, \quad \text{MPa} \quad (9.9)$$

Squeezing ground condition

$$p_v(\text{sq}) = \left[\frac{f(N)}{30} \right] \cdot 10 \left[\frac{H^{0.6} \cdot a^{0.1}}{50 \cdot N^{0.33}} \right], \quad \text{MPa} \quad (9.10)$$

Rock mass number

TABLE 9.3
CORRECTION FACTOR FOR TUNNEL CLOSURE IN EQN. 9.10 (GOEL ET AL., 1995a)

| S.No. | Degree of Squeezing | Normalized Tunnel Closure % | f(N) |
|-------|---|-----------------------------|------|
| 1. | Very mild squeezing ($270 N^{0.33} \cdot B^{-0.1} < H < 360 N^{0.33} \cdot B^{-0.1}$) | 1 - 2 | 1.5 |
| 2. | Mild squeezing ($360 N^{0.33} \cdot B^{-0.1} < H < 450 N^{0.33} \cdot B^{-0.1}$) | 2 - 3 | 1.2 |
| 3. | Mild to moderate squeezing ($450 N^{0.33} \cdot B^{-0.1} < H < 540 N^{0.33} \cdot B^{-0.1}$) | 3 - 4 | 1.0 |
| 4. | Moderate squeezing ($540 N^{0.33} \cdot B^{-0.1} < H < 630 N^{0.33} \cdot B^{-0.1}$) | 4 - 5 | 0.8 |
| 5. | High squeezing ($630 N^{0.33} \cdot B^{-0.1} < H < 800 N^{0.33} \cdot B^{-0.1}$) | 5 - 7 | 1.1 |
| 6. | Very high squeezing ($800 N^{0.33} \cdot B^{-0.1} < H$) | >7 | 1.7 |

Notations: N = rock mass number; H = tunnel depth in metres; B = tunnel width in metres (refer Chapter 7, Table 7.4)

Note: Tunnel closure depends significantly on the method of excavation. In highly squeezing ground condition, heading and benching method of excavation may lead to tunnel closure > 8%.

where,

$p_r(e)$ = short-term roof support pressure in non- squeezing ground condition in MPa,

$p_r(sq)$ = short-term roof support pressure in squeezing ground condition in MPa,

f(N) = correction factor for tunnel closure obtained from Table 9.3, and

H & B = tunnel depth & tunnel width in metres respectively.

The above correlations have been evaluated using measured support pressures and the correlation coefficient of 0.96 and 0.95 is obtained for Eqns. 9.9 and 9.10 respectively (Goel et al., 1995a). It is also found that even for larger tunnels in squeezing ground conditions the estimated support pressures (Eqn. 9.10) are matching with the measured values.

Equations 9.9 and 9.10 have been used to develop nomograms shown in Figures 9.3 and 9.4, respectively to estimate support pressure in tunnels. Figure 9.4 is in two parts; part (a) is used to get p' and using this value of p' , subsequently, in part (b) the support pressure p_r in squeezing ground condition is obtained after applying the correction for tunnel closure. These nomograms can be used as follows to obtain the support pressure.

- (i) Mark the point on the lines of tunnel depth H and tunnel radius a for the given values of H and a (Figures 9.3 and 9.4a),

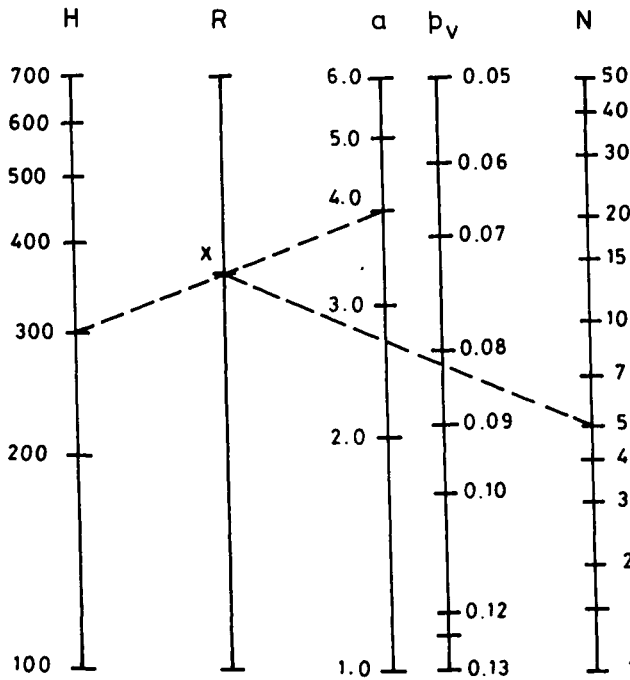

Figure 9.3: Nomogram of Eqn. 9.9 for obtaining rock support pressure in MPa in non-squeezing ground conditions

- (ii) Join these two points by a straight line. This line will intersect the reference line R of the nomogram at a point say point 'X' (see Figures 9.3 and 9.4a),
- (iii) Mark the point on the line of rock mass number N for its given value. Join this point with point X by a straight line and extend this line so as to intersect line p_v and p' in Figures 9.3 and 9.4a respectively. The p_v value, thus obtained from Figure 9.3, would be the estimated support pressure in non-squeezing ground conditions.
- (iv) For obtaining the support pressure in squeezing ground conditions, as mentioned above, the p' value obtained from Figure 9.4a is used with the known value of correction factor for tunnel closure $f(N)$ in Figure 9.4b. Mark the p' and $f(N)$ values on their respective lines in Figure 9.4b. Join these two points by a straight line and extend this line to intersect the p_v line. This would be the estimated support pressure in squeezing ground conditions.

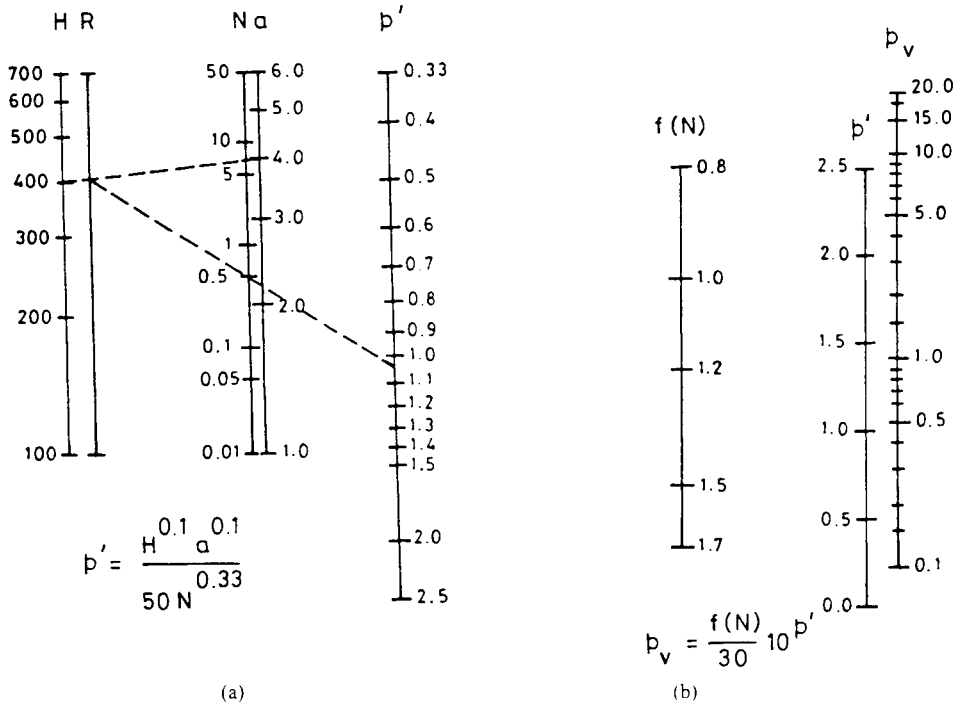

Figure 9.4: Nomogram of Eqn. 9.10 in two parts (a) for obtaining p' , i.e., support pressure without correction for tunnel closure $f(N)$ and (b) to obtain roof support pressure p_v using p' and $f(N)$

9.5 Effect of Tunnel Size on Support Pressure

Prediction of support pressures in tunnels and the effect of tunnel size on support pressure are the two important problems of tunnel mechanics which attracted the attention of many researchers. The matter presented here on the effect of tunnel size on support pressure has been taken from Goel et al. (1996).

Various empirical approaches of predicting support pressures have been developed in the recent past. Some researchers demonstrated that the support pressure is independent of tunnel size (Daemen, 1975; Jethwa, 1981; Barton et al., 1974; Singh et al., 1992), whereas other advocated that the support pressure is directly dependent on tunnel size (Terzaghi, 1946; Deere et al., 1969; Wickham et al., 1972; Unal, 1983). A review on the effect of tunnel size on support pressure with a concept proposed by Goel (1994) is presented for highlighting the effect of tunnel size on support pressure.

9.5.1 Review of Existing Approaches

Empirical approaches of estimating support pressure have been presented in Table 9.4 to study the effect of tunnel size on support pressure. A discussion is presented below.

TABLE 9.4
IMPORTANT EMPIRICAL APPROACHES AND THEIR RECOMMENDATIONS (GOEL ET AL., 1996)

| Approach | Results Based on | Recommendations |
|--|--|--|
| Terzaghi (1946) | a. experiments in sands b. rectangular openings with flat roof c. qualitative approach | support pressure increases with the opening size |
| Deere et al. (1969) | a. based on Terzaghi's theory and classification on the basis of RQD | support pressure increases with the opening size |
| Wickham et al.(1972) RSR - system | a. arched roof b. hard rocks c. quantitative approach | support pressure increases with the opening size |
| Barton et al. (1974) Q - system | a. hard rocks b. arched roof c. quantitative approach | support pressure is independent of the opening size |
| Unal (1983) using RMR of Bieniawski (1973) | a. coal mines b. rectangular openings with flat roof c. quantitative approach | support pressure increases with the opening size |
| Singh et al. (1992) | a. arched roof (tunnel /cavern) b. both hard and weak rocks c. quantitative approach | Support pressure is observed to be independent of the opening size (2 - 22m) |

a. Influence of shape of the opening

Some empirical approaches listed in Table 9.4 have been developed for flat roof and some for arched roof. In case of an underground opening with flat roof, the support pressure is generally found to vary with the width or size of the opening, whereas in arched roof the support pressure is found to be independent of tunnel size (Table 9.4). RSR - system of Wickham et al. (1972) is an exception in this regard, probably because the system, being conservative, was not backed by actual field measurements for caverns. The mechanics suggests that the normal forces will be more in case of a rectangular opening with flat roof by virtue of the detached rock block in the tension zone which is free to fall.

b. Influence of rock mass type

The support pressure is directly proportional to the size of the tunnel opening in the case of weak or poor rock masses, whereas in good rock masses the situation is reverse (Table 9.4). Hence, it can be inferred that the applicability of an approach developed for weak or poor rock masses has a doubtful application in good rock masses.

Rock mass number

Goel et al. (1995a) have evaluated the approaches of Barton et al. (1974) and Singh et al. (1992) using the measured tunnel support pressures from 25 tunnel sections. They found that the approach of Barton et al. is unsafe in squeezing ground conditions and the reliability of the approaches of Singh et al. (1992) and that of Barton et al. depend upon the rating of Barton's Stress Reduction Factor (SRF). It has also been found out that the approach of Singh et al. is unsafe for larger tunnels in squeezing ground conditions.

9.5.2 New Concept on Effect of Tunnel Size on Support Pressure

Equations 9.9 and 9.10 have been used to study the effect of tunnel size on support pressure which is summarised in Table 9.5.

TABLE 9.5
EFFECT OF TUNNEL SIZE ON SUPPORT PRESSURE (GOEL ET AL., 1996)

| S. No. | Type of Rock Mass | Increase in Support Pressure Due to Increase in Tunnel Span or Dia. from 3m to 12m |
|---|---|--|
| A. TUNNELS WITH ARCHED ROOF | | |
| 1. | Non-squeezing ground conditions | Up to 20 percent only |
| 2. | Poor rock masses / squeezing ground conditions ($N = 0.5$ to 10) | 20 - 60 percent |
| 3. | Soft-plastic clays, running ground, flowing ground, clay-filled moist fault gouges, slickensided shear zones ($N = 0.1$ to 0.5) | 100 percent |
| B. TUNNELS WITH FLAT ROOF (irrespective of ground conditions) | | up to 100 percent |

It is cautioned that the support pressure is likely to increase significantly with the tunnel size for tunnel sections excavated through the following situations:

- (i) slickensided zone,
- (ii) thick fault gouge,
- (iii) weak clay and shales,
- (iv) soft plastic clays,
- (v) crushed brecciated and sheared rock masses,
- (vi) clay filled joints, and
- (vii) extremely delayed support in poor rock masses.

9.6 Correlations for Estimating Tunnel Closure

Behaviour of concrete, gravel and tunnel muck backfills, commonly used with steel arch supports, has been studied. Stiffness of these backfills has been estimated using measured

support pressures and tunnel closures. These results have been used finally to obtain effective support stiffness of the combined support system of steel rib and backfill (Goel, 1994).

On the basis of measured tunnel closures from 60 tunnel sections, correlations have been developed for predicting tunnel closures in non- squeezing and squeezing ground conditions (Goel, 1994). The correlations are given below:

Non-squeezing ground condition

$$\frac{u_a}{a} = \frac{H^{0.6}}{28. N^{0.4} . K^{0.35}} \quad \% \quad (9.11)$$

Squeezing ground condition

$$\frac{u_a}{a} = \frac{H^{0.8}}{10. N^{0.3} . K^{0.6}} \quad \% \quad (9.12)$$

where,

u_a/a = normalised tunnel closure in per cent.

K = effective support stiffness in MPa, and

H & a = tunnel depth & tunnel radius (half of tunnel width) in metres respectively.

These correlations can also be used to obtain desirable effective support stiffness so that the normalised tunnel closure is contained within 4 to 5 percent.

9.7 Effect of Tunnel Depth on Support Pressure and Closure in Tunnels

It is known that the insitu stresses are influenced by the depth below the ground surface. It is also learned from the theory that the support pressure and the closure for tunnels are influenced by the insitu stresses. Therefore, it is recognized that the depth of tunnel or the overburden is an important parameter while planning and designing the tunnels. The tunnel depth or the overburden effect on support pressure and closure in tunnel have been studied using Eqns. 9.9 to 9.12 under both squeezing and non-squeezing ground conditions which is summarized below.

- (i) The tunnel depth has a significant effect on support pressure and tunnel closure in squeezing ground conditions. It has practically no effect under non-squeezing ground conditions, however.
- (ii) The tunnel depth effect is higher on the support pressure than the tunnel closure.

Rock mass number

- (iii) The depth effect on support pressure increases with deterioration in rock mass quality probably because the confinement decreases and the degree of freedom for the movement of rock blocks increases.
- (iv) This study would be of help to planners and designers to take decisions on realigning a tunnel through a better tunnelling media or a lesser depth or both in order to reduce the anticipated support pressure and closure in tunnels.

9.8 Approach for Obtaining Ground Reaction Curve (GRC)

According to Daemen (1975), ground reaction curve is quite useful for designing the supports specially for tunnels through squeezing ground conditions. An easy to use empirical approach for obtaining the ground reaction curve has been developed using Eqns. 9.10 and 9.12 for tunnels in squeezing ground conditions. The approach has been explained with the help of an example.

Example:

For the example, the tunnel depth H and the rock mass number N have been assumed as 500m and 1 respectively and the tunnel radius 'a' as 5m. The radial displacement of the tunnel is u_a for a given support pressure $p_v(\text{sq})$.

GRC Using Eqn. 9.10

In Equation 9.10, as described earlier, $f(N)$ is the correction factor for tunnel closure. For different values of permitted normalized tunnel closure (u_a/a), different values of $f(N)$ are proposed in Table 9.3. Using Table 9.3 and Eqn. 9.10, the support pressures [$p_v(\text{sq})$] have been estimated for the assumed boundary conditions and for various values of u_a/a (column 1) as shown in Table 9.6. Subsequently, using value of p_v (column 3) and u_a/a (column 1) from Table 9.6, GRC has been plotted for u_a/a up to 5 per cent (Figure 9.5).

GRC Using Eqn. 9.12

For obtaining GRC from Eqn. 9.12, the following equation of support stiffness would also be used.

$$K = [p_v / (u_a/a)] \quad (9.13)$$

It is important to mention that u_a/a value for estimating K from Eqn. 9.13 should be a dimensionless quantity and not in percentage. It means that instead of 1 per cent, the u_a/a value would be 0.01 in Eqn. 9.13.

Using the values of u_a/a (dimensionless corresponding to percentage value) and $p_v(sq)$ from columns 1 and 3 respectively of Table 9.6 in Eqn. 9.13, K values (column. 4, Table 9.6) have been obtained.

TABLE 9.6
SHOWING CALCULATIONS FOR CONSTRUCTING GRC USING EQNS. 9.10 AND 9.12

| Assumed u_a/a (%) | Correction Factor (f) | $p_v(sq)$ from Eq. 9.10 (MPa) | K from Eq. 9.13 using col. 1 & 3 (MPa) | u_a/a from Eq.9.12 for K at col. 3 (%) | f for u_a/a at col. 5 | $p_v(sq)$ from Eq. 9.10 (MPa) | p_v from Eq. 9.13 using col. 4 & 5 (MPa) |
|---------------------|-----------------------|-------------------------------|--|--|-------------------------|-------------------------------|--|
| (1) | (2) | (3) | (4) | (5) | (6) | (7) | (8) |
| 0.5 | 2.7 | 0.86 | 172 | 0.59 | 2.6 | 0.82 | 1.03 |
| 1 | 2.2 | 0.7 | 70 | 1.04 | 2.2 | 0.69 | 0.73 |
| 2 | 1.5 | 0.475 | 23.75 | 2.05 | 1.4 | 0.44 | 0.48 |
| 3 | 1.2 | 0.38 | 12.66 | 3.02 | 1.15 | 0.36 | 0.38 |
| 4 | 1.0 | 0.317 | 7.9 | 4.02 | 1 | 0.31 | 0.32 |
| 5 | 0.8 | 0.25 | 5.06 | 5.37 | 0.85 | 0.27 | 0.27 |

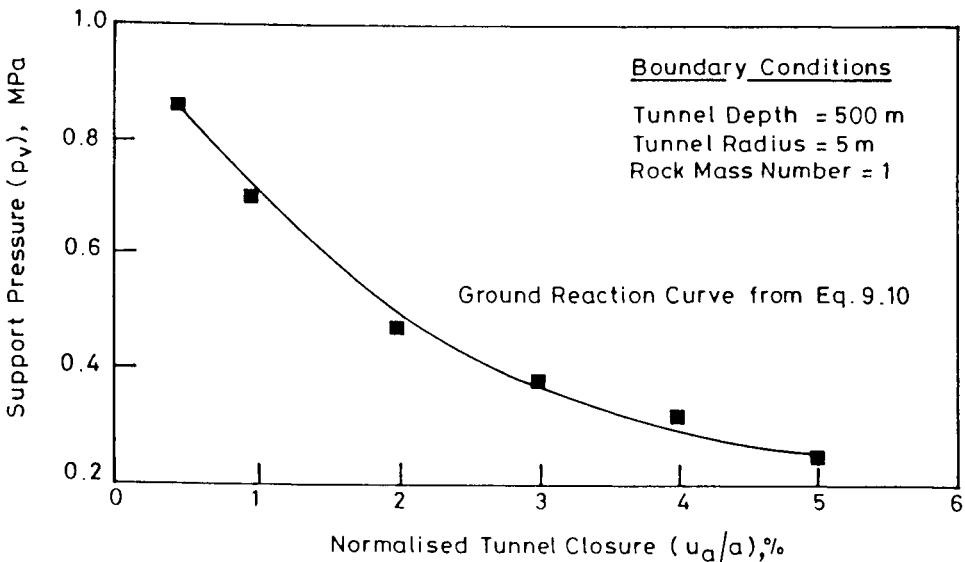

Figure 9.5 : Ground reaction curve obtained from Eqn. 9.10

Using this K value in Eqn. 9.14, normalized tunnel closure (u_a/a) is calculated for given boundary conditions ($H = 500m$ and $N = 1$) and tabulated in column 5, Table 9.6. This value of normalized tunnel closure, subsequently, is used to obtain support pressure from Eqn. 9.10 (Column 7, Table 9.6) or from Eqn. 9.13 (Column 8, Table 9.6). Three sets of values of support pressures and normalized closures are available for plotting three ground reaction

Rock mass number

curves. One set of data is given in Columns 1 and 3 (Figure 9.5), second set is from columns 5 and 7, whereas the third set is represented by columns 5 and 8.

It is interesting to see that though the two equations (Eqns 9.10 and 9.12) have been developed using different data and case histories, the ground reaction curves obtained from these two equations (Columns 1 & 3 and Columns 5 & 7) are practically identical.

It may be highlighted here that the approach is simple, reliable and user friendly because the values of the input parameters can be easily obtained in the field.

9.9 Coefficient of Volumetric Expansion of Failed Rock Mass

The ground response (reaction) curve depends upon the strength parameters of rock mass and also the coefficient of volumetric expansion of rock mass (k) in the broken zone. Jethwa (1981) estimated values of k as listed in Table 9.7. It may be noted that higher degree of squeezing was associated with higher k values.

TABLE 9.7
COEFFICIENT OF VOLUMETRIC EXPANSION OF FAILED ROCK MASS (k) WITHIN
BROKEN ZONE (JETHWA, 1981)

| S.No. | Rock Type | k |
|-------|-------------------------|-------|
| 1. | Phyllites | 0.003 |
| 2. | Claystones / Siltstones | 0.01 |
| 3. | Black clays | 0.01 |
| 4. | Crushed sandstones | 0.004 |
| 5. | Crushed shales | 0.005 |
| 6. | Metabasics (Goel, 1994) | 0.006 |

References

- Abad, J., Caleda, B., Chacon, E., Gutierrez, V. and Hidlgo, E. (1984). Application of Geomechanical Classification to Predict the Convergence of Coal Mine Galleries and to Design their Supports, *5th Int. Congress on Rock Mech.*, Melbourne, (E), pp. 15-19.
- Barton, N., Lien, R. and Lunde, J. (1974). Analysis of Rock Mass Quality and Support Practice in Tunnelling, and a Guide for Estimating Support Requirements. **NGI Internal Report No. 54206**, June.
- Barton, N., Lien, R. and Lunde, J. (1974). Engineering Classification of Rock Masses for the Designs of Tunnel Supports. *Rock Mechanics*, Springer-Verlag, **6**, 189-236.
- Bieniawski, Z. T. (1973). Engineering Classification of Jointed Rock Masses. *Trans. S. African Instn. Civil Engrs.*, **Vol. 15**, pp. 335-342.
- Bieniawski, Z. T. (1989). *Engineering Rock Mass Classifications*, John Wiley, Rotterdam, 251p.

- Cameron-Clarke, I. S. and Budavari, S. (1981). Correlation of Rock Mass Classification Parameters Obtained from Borecore and Insitu Observations, *Engineering Geology*, Elsevier Science, **Vol. 17**, pp. 19-53.
- Daemen, J. J. K. (1975). Tunnel Support Loading Caused by Rock Failure, *Ph. D. Thesis, University of Minnesota*, Minneapolis, U.S.A.
- Deere, D. U., Peck, R. B., Monsees, J. E. and Schmidt, B. (1969). Design of Tunnel Liners and Support System, *U.S. Department of Transportation, Highway Research Record No. 339*, Washington D.C.
- Goel, R. K. (1994). Correlations for Predicting Support Pressures and Closures in Tunnels, *Ph.D. Thesis, Nagpur University*, India, p. 308.
- Goel, R. K., Jethwa, J. L. and Paithankar, A.G. (1995a). Indian Experiences with Q and RMR Systems, *Jr. Tunnelling and Underground Space technology*, Pergamon, **Vol. 10, No. 1**, pp. 97-109.
- Goel, R. K., Jethwa, J. L. and Paithankar, A. G. (1995b). Correlation Between Barton's Q and Bieniawski's RMR - A New Approach, Technical Note, *Int. Jr. Rock Mech. Min. Sci. & Geomech. Abstr.*, Pergamon, **Vol. 33, No. 2**, pp. 179 -181.
- Goel, R. K., Jethwa, J. L. and Dhar, B. B. (1996). Effect of Tunnel Size on Support Pressure, Tech. Note, *Int. Jr. Rock Mech. Min. Sci. & Geomech. Abstr.*, Pergamon, **Vol. 33, No. 7**, pp. 749-755.
- Hoek, E. and Brown, E.T. (1980). *Underground Excavations in Rock*, Institution of Mining and Metallurgy, London.
- Jethwa, J. L. (1981). Evaluation of Rock Pressure Under Squeezing Rock Conditions for Tunnels in Himalayas, *Ph. D. Thesis, University of Roorkee*, India.
- Kaiser, P. K., Mackay, C. and Gale, A. D. (1986). Evaluation of Rock Classifications at B. C. Rail Tumbler Ridge Tunnels, *Rock Mechanics & Rock Engineering*, Springer-Verlag, **19**, pp. 205-234.
- Lama, R. D. and Vutukuri, V. S. (1978). *Handbook on Mechanical Properties of Rocks*, Trans Tech Publications, **Vol. 2**, 481p.
- Moreno Tallon, E. (1980). Application de Las Clasificaciones Geomechanicas a Los Tuneles de Parjares, II Cursode Sostenimientos Activosen Galeriasy Tunnels. Madrid: Foundation Gomez - Parto [referred in Kaiser et al. (1986)].
- Rutledge, J. C. and Preston, R. L. (1978). Experience with Engineering Classifications of Rock, *Proc. Int. Tunnelling Sym.*, Tokyo, pp. A3.1 -A3.7.
- Sheorey, P. R. (1993). Experiences with the Applications of Modern Rock Classification in Coal Mine Roadways, *Comprehensive Rock Engineering*, Editors J. A. Hudson et al., Pergamon, **Vol. II**.
- Singh, Bhawani, Jethwa, J. L., Dube, A.K. and Singh, B. (1992). Correlation Between Observed Support Pressure and Rock Mass Quality, *Jr. Tunnelling and Underground Space Technology*, Pergamon, **Vol. 7**, pp. 59-75.
- Singh, Bhawani, Goel, R. K., Jethwa, J. L. and Dube, A.K. (1997). Support Pressure Assessment in Arched Underground Openings through Poor Rock Masses, *Engineering Geology*, Elsevier Science, **48**, pp. 59-81.
- Terzaghi, K. (1946). *Rock Defects and Load on Tunnel Supports, Introduction to Rock Tunnelling with Steel Supports*, R. V. Proctor and T. C. White, Youngstown, Ohio, USA. Commercial Shearing and Stamping (1946).
- Unal, E. (1983). Design Guidelines and Roof Control Standards for Coal Mine Roofs, *Ph. D. Thesis, Pennsylvania State University* [reference Bieniawski (1989)].

Rock mass number

Wickham, G.E., Tiedmann, H. R. and Skinner, E. H. (1972). Support Determination Based on Geologic Predictions, *Proc. Rapid Excavation Tunnelling Conference*, pp. 43-64, AIME, New York.

ROCK MASS INDEX

10.1 Introduction

There is no single parameter which can fully designate the properties of jointed rock masses. Various parameters have different significance and only in an integrated form they can describe a rock mass satisfactorily.

Palmstrom (1995) has proposed a Rock Mass Index RMI to characterise rock mass strength as a construction material. The presence of various defects (discontinuities) in a rock mass that tend to reduce the inherent strength of the rock mass index (RMI) is expressed as

$$\text{RMI} = q_c \cdot J_p \quad (10.1)$$

where,

- q_c = the uniaxial compressive strength of the intact rock material in MPa,
- J_p = the jointing parameter composed of mainly four jointing characteristics, namely block volume or density of joints, joint roughness, joint alteration and joint size. It is a reduction coefficient representing the effect of the joints in a rock mass. The value of J_p varies from almost 0 for crushed rock masses to 1 for intact rocks = s^n Hoek and Brown's criterion, and
- RMI = rock mass index denoting uniaxial compressive strength of the rock mass in MPa.

10.2 Selection of Parameters used in RMI

For jointed rock masses, Hoek et al. (1992) are of the opinion that the strength characteristics are controlled by the block shape and size as well as their surface characteristics determined by the intersecting joints. They recommend that these parameters are selected to represent the average condition of the rock mass. Similar ideas have been proposed earlier by Tsoutrelis et al. (1990), and Matula and Holzer (1978).

This does not mean, that the properties of the intact rock material should be disregarded in rock mass characterisation. After all, if joints are widely spaced or if an intact rock is weak, the properties of the intact rock may strongly influence the gross behaviour of the rock mass. The rock material is also important if the joints are discontinuous. In addition, the rock description will inform the reader on the geology and the type of material at the site, although rock properties in many cases are downgraded by joints. It should be borne in mind that the properties of rocks have a profound influence on the formation and development of joints. Petrological data can make an important contribution towards the prediction of mechanical

performance, provided that one looks beyond the rock names at the observations on which they are based (Franklin, 1970). It is therefore, important to retain the names for the different rock types, for these in themselves give relative indications of their inherent properties (Piteau, 1970).

These considerations and study of more than 15 different classification systems have been used by Palmstrom (1995) in the selection of the following input parameters to RMI :

- (i) the size of the blocks delineated by joints - measured as block volume, V_b ;
- (ii) the strength of the block material - measured as uniaxial compressive strength, q_c ;
- (iii) the shear strength of the block faces - characterized by factors for the joint characteristics, j_R and j_A (Tables 10.1 and 10.3); and
- (iv) the size and termination of the joints - given as their length and continuity factor, j_L (Table 10.2).

10.3 Calibration of RMI from Known Rock Mass Strength Data

It is practically impossible to carry out triaxial or shear tests on rock masses at a scale which is of the same size as that of underground excavations (Hoek and Brown, 1988). As the rock mass index, RMI, is meant to express the compressive strength of a rock mass, a calibration of the same is necessary.

The uniaxial compressive strength of intact rock, q_c is defined and can be determined within a reasonable accuracy. The jointing parameter (J_p), however, is a combined parameter made up of

- the block volume, V_b , which can be found from field measurements, and
- the joint condition factor, j_C , which is the result of three independent joint parameters (roughness, alteration and size).

Results from large scale tests and field measurements of rock mass strength have been used to determine how V_b and j_C can be combined to express the jointing parameter, J_p . The calibration has been performed using known test results of the uniaxial compressive strength and the inherent parameters of the rock mass. The values for V_b and j_C have been plotted in Figure 10.1 and the lines representing j_C have been drawn. These lines are expressed as

$$J_p = 0.2 (j_C)^{0.5} \cdot (V_b)^D \quad (10.2)$$

where V_b is given in m^3 , and $D = 0.37 \cdot j_C^{-0.2}$.

Joint condition factor j_C is correlated with j_R , j_A and j_L as follows:

$$j_C = j_L (j_R/j_A) \quad (10.3)$$

Various parameters of R_{Mi} and their combination in Rock Mass Index R_{Mi} are shown in Figure 10.2, whereas the ratings of joint roughness j_R, joint size and termination j_L and joint alteration j_A are given in Tables 10.1, 10.2 and 10.3 respectively. Joint roughness j_R together with joint alteration j_A define the friction angle as in the Q-system of Barton et al. (1974). The classification of R_{Mi} is presented in Table 10.4.

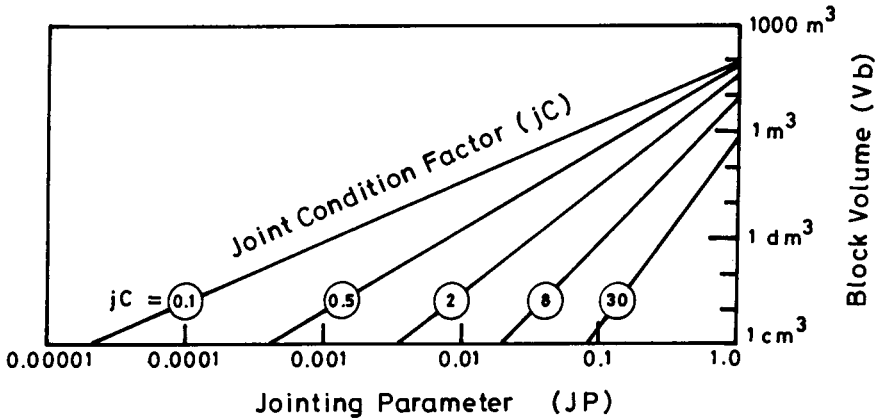

Figure 10.1 : The graphical combination of block volume (V_b), joint condition factor (j_C) and jointing parameter (J_p)

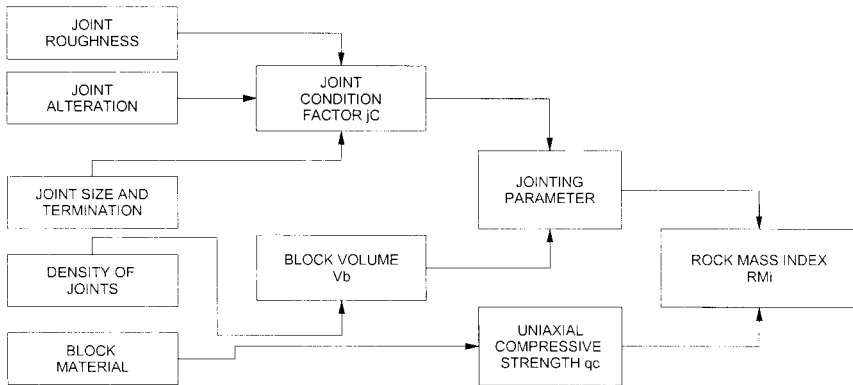

Figure 10.2 : The combination of the parameters used in R_{Mi} (Palmstrom, 1996)

Most commonly, j_C and J_p are given as

$$j_C = 0.2 V_b^{0.37} \text{ and } J_p = 0.28 V_b^{0.32}$$

For j_C = 1.75 the jointing parameter can simply be expressed as

Rock mass index

$$J_p = 0.25 (Vb)^{0.33}$$

and for $jC = 1$ the jointing parameter is expressed as

$$J_p = 0.2 Vb^{0.37} \text{ (Eqn. 10.2)}$$

10.4 Scale Effect

Significant scale effects are generally involved when a sample size is enlarged from laboratory size to field size. From the calibration described above, RMi is related to large samples where the scale effect has been included in J_p . The joint size factor (jL) is also a scale variable. For massive rock masses, however, where the jointing parameter $J_p \approx 1$, the scale effect for the uniaxial compressive strength (q_c) must be accounted for, as q_c is related to 50 mm sample size. Barton (1990) suggests from data presented by Hoek and Brown (1980) and Wagner (1987) that the actual compressive strength for large field samples with diameter (d , measured in mm.) may be determined using the following equation (Figure 10.3).

$$q_c = q_{c0} (50/d)^{0.2} = q_{c0} (0.05/Db)^{0.2} = q_{c0} \cdot f \quad (10.4)$$

where q_{c0} is the uniaxial compressive strength for 50mm sample size.

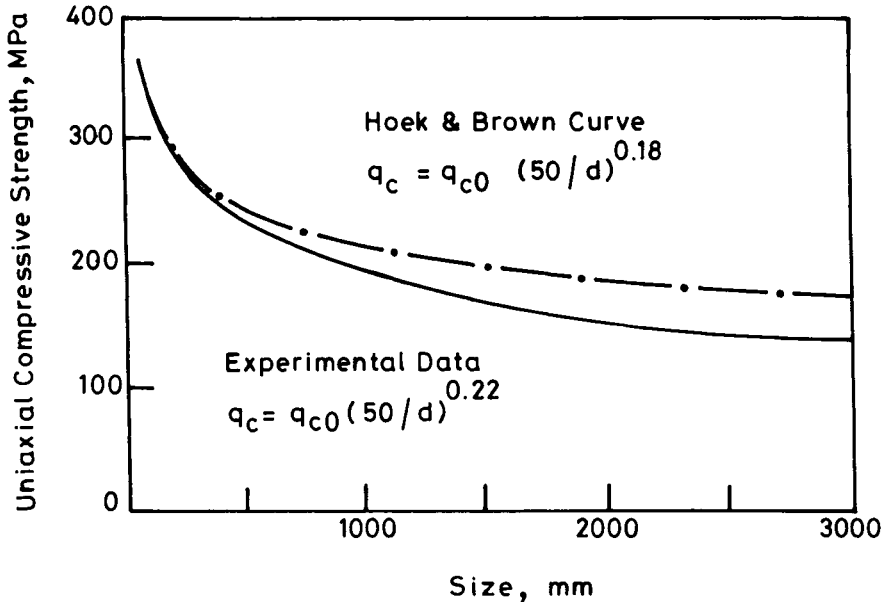

Figure 10.3 : Empirical equations for scale effect of uniaxial compressive strength (from Barton, 1990 based on data from Hoek and Brown, 1980 and Wagner, 1987)

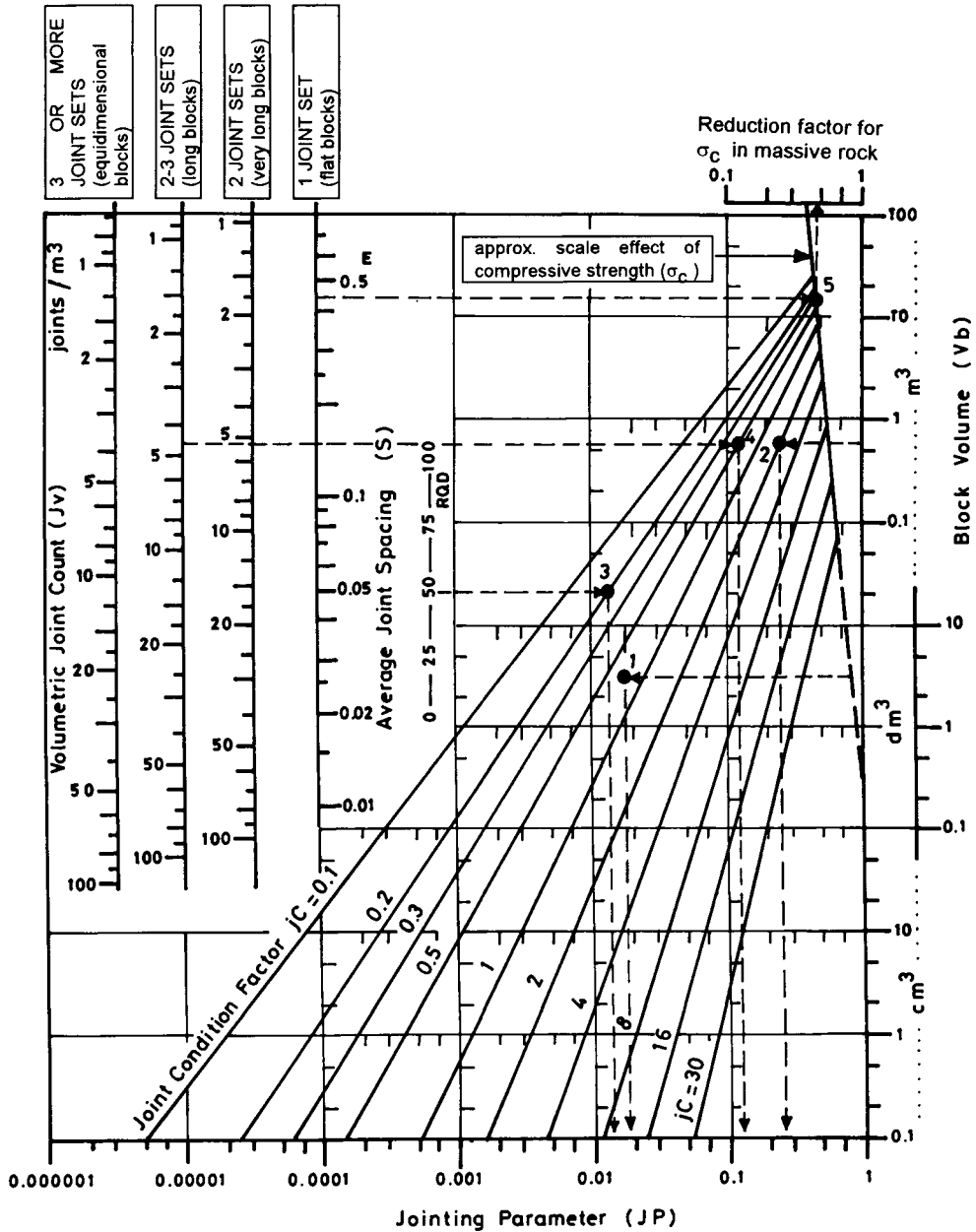

Figure 10.4: The jointing parameter J_p found from the joint condition factor jC and various measurements of jointing intensity (V_b , J_v , RQD) (Palmstrom, 1996)

Rock mass index

Equation 10.4 is valid for sample diameter up to some metres. and may, therefore, be applied for massive rock masses. $f = (0.05/Db)^{0.2}$ is the scale factor for compressive strength. The approximate block diameter in Eqn. 10.4 may be found from $Db = (Vb)^{0.33}$, or, where a pronounced joint set occurs, simply by applying the spacing of this set.

Figure 10.4 shows the same diagram as Figure 10.1 where other measurements than block volume can also be applied to determine jC . These are shown in the upper left part in the diagram. Here, the volumetric joint count (J_v) for various joint sets (and/or block shapes) can be used instead of the block volume. Also, RQD can be used, but its inability to characterise massive rock and highly jointed rock masses leads to reduced value of J_p .

TABLE 10.1
THE JOINT ROUGHNESS jR FOUND FROM SMOOTHNESS AND WAVINESS (PALMSTROM, 1996)

| Small Scale Smoothness* of Joint Surface | Large Scale Waviness of Joint Plane | | | | |
|--|-------------------------------------|---------------------|---------------------|---------|--------------|
| | Planar | Slightly undulating | Strongly undulating | Stepped | Interlocking |
| Very rough | 3 | 4 | 6 | 7.5 | 9 |
| Rough | 2 | 3 | 4 | 5 | 6 |
| Slightly rough | 1.5 | 2 | 3 | 4 | 4.5 |
| Smooth | 1 | 1.5 | 2 | 2.5 | 3 |
| Polished | 0.75 | 1 | 1.5 | 2 | 2.5 |
| Slickensided** | 0.6-1.5 | 1-2 | 1.5-3 | 2-4 | 2.5-5 |
| For irregular joints a rating of $jR = 5$ is suggested | | | | | |

* for filled joints: $jR = 1$; ** for slickensided joints the value of R depends on the presence and outlook of the striations; the highest value is used for marked striations

TABLE 10.2
THE JOINT LENGTH AND CONTINUITY FACTOR jL (PALMSTROM, 1996)

| Joint Length (m) | Term | Type | jL | |
|------------------|-----------------|------------------------------|-------------------|------------------------|
| | | | Continuous joints | Discontinuous joints** |
| < 0.5 | Very short | Bedding/foliation parting | 3 | 6 |
| 0.1 - 1.0 | Short/small | Joint | 2 | 4 |
| 1 - 10 | Medium | Joint | 1 | 2 |
| 10 - 30 | Long/large | Joint | 0.75 | 1.5 |
| > 30 | Very long/large | Filled joint seam* or shear* | 0.5 | 1 |

* often a singularity, and should in these cases be treated separately
 ** Discontinuous joints end in massive rock mass

TABLE 10.3
CHARACTERISATION AND RATING OF THE JOINT ALTERATION FACTOR j_A (PALMSTROM, 1996)

| Term | Description | j_A | |
|--|--|--|--|
| A. Contact between rock wall surfaces | | | |
| <i>Clean joints</i> Healed or welded joints | Softening, impermeable filling (quartz, epidote, etc.) | 0.75 | |
| Fresh rock walls | No coating or filling on joint surface, except of staining | 1 | |
| <i>Alteration of joint wall</i> i. 1 grade more altered | The joint surface exhibits one class higher alteration than the rock | 2 | |
| ii. 2 grade more altered | The joint surface shows two classes higher alteration than the rock | 4 | |
| <i>Coating or thin filling</i> Sand, silt, calcite, etc. | Coating of friction materials without clay | 3 | |
| Clay, chlorite, talc, etc. | Coating of softening and cohesive minerals | 4 | |
| B. Filled joints with partly or no contact between the rock wall surfaces | | | |
| Type of Filling Material | Description | Partly Wall Contact (thin filling <5mm*) | No Wall Contact (thick filling or gouge) |
| Sand, silt, calcite, etc. | Filling of friction material without clay | 4 | 8 |
| Compacted clay materials | "Hard" filling of softening and cohesive materials | 6 | 10 |
| Soft clay materials | Medium to low over-consolidation of filling | 8 | 12 |
| Swelling clay materials | Filling material exhibits clear swelling properties | 8-12 | 12-20 |

* Based on joint thickness division in the RMR system (Bieniawski, 1973)

TABLE 10.4
CLASSIFICATION OF RM_i (PALMSTROM, 1996)

| TERM | | RM_i VALUE |
|----------------|-------------------------------|--------------|
| for RM_i | Related to Rock Mass Strength | |
| Extremely low | Extremely weak | <0.001 |
| Very low | Very weak | 0.001-0.01 |
| Low | Weak | 0.01-0.1 |
| Moderate | Medium | 0.1-1.0 |
| High | Strong | 1.0-10.0 |
| Very high | Very strong | 10-100 |
| Extremely high | Extremely strong | >100 |

10.5 Examples (Palmstrom, 1995)

Example 1

The block volume has been measured as $V_b = 0.003 \text{ m}^3$. From the following condition and using Tables 10.1-10.3, the value of joint condition factor is worked out as $j_C = 0.75$.

* rough joint surfaces and small undulations of the joint wall which gives $j_R = 3$ and

* clay-coated joints, i.e. $j_A = 4$; and 3-10m long, continuous joints gives $j_L = 1$.

On applying the values for V_b and j_C in Figure 10.4, a value of $J_p = 0.02^{**}$ is found. With a compressive strength of the rock $q_c = 150 \text{ MPa}$, the value of $RM_i = 3$ (strong rock).

(** using Eqn. 10.2, a value of $J_p = 0.018$ is found)

Example 2

The block volume $V_b = 0.63 \text{ m}^3$. The joint condition factor $j_C = 2$ is determined from Tables 10.1-10.3 based on:

* smooth joint surfaces and planar joint walls which gives $j_R=4$;

* fresh joints, $j_A=1$; and 1-3 m long discontinuous joints, i.e., $j_L = 3$.

From Figure 10.4 the value $J_p = 0.25^{**}$ is found. With a compressive strength $q_c = 50 \text{ MPa}$, the value of $RM_i = 12.5$ (very strong rock).

(** $J_p = 0.24$ is found using Eqn. 10.2)

Example 3

Values of $RQD = 50$ and $j_C = 0.2$ give $J_p = 0.015$ as shown in Figure 10.4.

Example 4

Two joint sets spaced 0.3 m and 1m and some random joints have been measured. The volumetric joint count $J_v = (1/0.3)+(1/1)+0.5^{**} = 4.5$

With a joint condition factor $j_C = 0.5$, the jointing parameter $J_p = 0.12$ (using the columns for 2 - 3 joint sets in Figure 10.4)

(** assumed influence from the random joints)

Example 5

Jointing characteristics: one joint set with spacing $S = 0.45\text{m}$ and $j_C = 8$.

For the massive rock; the value of J_p is determined from the reduction factor for compressive strength $f = 0.45$. For a rock with $q_c = 130 \text{ MPa}$ the value of $RM_i = 59.6$ (very strong rock mass).

10.6 Applications of R_{Mi}

Figure 10.5 shows the main areas of R_{Mi} application together with the influence of its parameters in different fields. The R_{Mi} values cannot be used directly in classification systems as many of them are composed of systems of their own. Some of the input parameters in R_{Mi} are sometimes similar to those used in the classifications and may then be applied more or less directly.

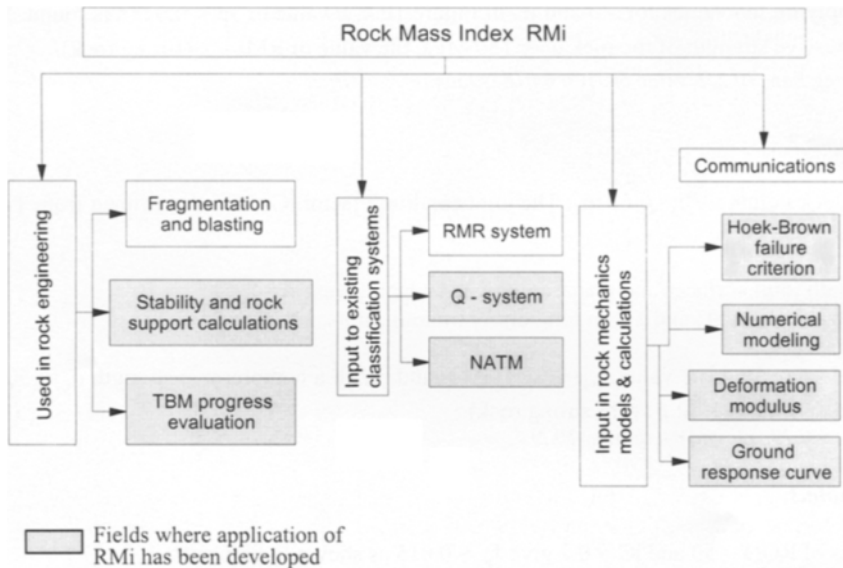

Figure 10.5 : Main applications of R_{Mi} in rock mechanics and rock engineering (Palmstrom, 1996)

The jointing parameter (J_p) in R_{Mi} is similar to the constant $s (= J_p^2)$ in the Hoek-Brown failure criterion for rock masses. R_{Mi} may, therefore, contribute in the future improvements of this criterion. The rock mass strength characteristics found from R_{Mi} can also be applied for numerical characterization in the NATM as well as for input to prepare ground response (reaction) curves (Table 10. 5).

Palmstrom (1995) claims that the application of R_{Mi} in rock support involves a more systematized collection and application of the input data. R_{Mi} also makes use of a clearer definition of the different types of ground. It probably covers a wider range of ground conditions and includes more variables than the two main classification systems, the RMR and the Q-system.

Rock mass index

TABLE 10.5
SUGGESTED NUMERICAL DIVISION OF GROUND ACCORDING TO NATM

| S.No. | NATM Class | Rock Mass / Ground Properties Represented by J_p | Competency Factor ($C_g = RMi / \sigma_\theta$) |
|-------|--------------------|--|---|
| 1. | Stable | Massive ground ($J_p > 0.5$) | >2 |
| 2. | Slightly ravelling | $0.2 < J_p < 0.6$ | >1 |
| 3. | Ravelling | $0.05 < J_p < 0.2$ | >1 |
| 4. | Strongly ravelling | $J_p < 0.05$ | 0.7-2.0 |
| 5. | Squeezing | Continuous ground | 0.35-0.7 |
| 6. | Strongly squeezing | Continuous ground | <0.35 |

σ_θ = maximum tangential stress along tunnel periphery

10.7 Benefits of Using RMI

As claimed by Palmstrom (1996), some of the benefits of using the RMI system in rock mechanics and rock engineering are:

- * RMI will enhance the accuracy of the input data required in rock engineering by its systematic approach of rock mass characterizations.
- * RMI can easily be used for rough estimates when limited information of the ground conditions is available, for example in early stages of a feasibility design of a project where rough estimates are sufficient.
- * RMI is well suited for comparisons and exchange of knowledge between different locations, as well as in general communication.
- * RMI offers a stepwise system suitable for engineering judgement.
- * It is easier and more accurate to find the values of s ($=J_p^2$ or J_p^{1-n}) using the RMI system than the methods outlined by Hoek and Brown (1980) which incorporate use of the RMR or the Q-system.
- * The RMI system covers a wide spectrum of rock mass variations and therefore has possibilities for wider applications than other rock mass classification and characterization systems.
- * The use of parameters in RMI can improve inputs in other rock mass classification systems and in NATM.

10.8 Limitations of RMI

As RMI is restricted to express only the compressive strength of rock masses, it has been possible to arrive at a simple expression, contrary to, for example, the general failure criterion

for jointed rock masses developed by Hoek and Brown (1980) and Hoek et al. (1992). Because simplicity has been preferred in the structure and in the selection of parameters in R_{Mi}; it is clear that such an index may result in inaccuracy and limitations, the most important of which are connected to:

* *The Range and Types of Rock Masses Covered by R_{Mi}*

Both the intact rock material as well as the joints exhibit great directional variations in composition and structure which results in an enormous range in compositions and properties for a rock mass. It is, therefore, not possible to characterize all these combinations in one, single number. However, it should be added that R_{Mi} probably may characterize a wider range of materials than most other classification systems.

* *The Accuracy in the Expression of R_{Mi}*

The value of the jointing parameter (J_p) is calibrated from a few large scale compression tests. Both the evaluation of the various factors (j_R , j_A and V_b) in J_p and the size of the samples tested - which in some of the cases did not contain enough blocks for being representative for a continuous rock mass - have resulted in that certain errors are connected to the expression developed for the J_p . In addition, the test results used were partly from dry, partly from wet samples, which further may have reduced the accuracy of the data. The value of R_{Mi} can, therefore, be approximate. In some cases, however, the errors in the various parameters may partly neutralize each other.

* *The Effect of Combining Parameters that Vary in Range*

The input parameters to R_{Mi} express generally a certain range of variation related to changes in the actual representative volume of a rock mass. Combination of these variables in R_{Mi} (and any other classification system) may cause errors.

It follows from the foregoing discussion that R_{Mi} in many cases will be inaccurate in characterizing the strength of such a complex assemblage of different materials and defects that a rock mass is composed of. For these reasons, R_{Mi} is regarded as a relative expression of the rock mass strength.

References

- Barton, N., Lien, R. and Lunde, J. (1974). Engineering Classification of Rock Masses for the Design of Rock Support, *Rock Mechanics*, Springer-Verlag, Vol. 6, 1974, pp. 189-236.
- Barton, N. (1990). Scale Effects or Sampling Bias? *Int. Workshop on Scale Effects in Rock Masses*, Balkema, Rotterdam, pp. 31-55. Reprinted from Pinto da Cunha, A. (ed), *Scale Effects in Roc Masses - Proceedings of the first international workshop*, Loen, 7-8.6.1990. 1990. 532 pp., Hfl. 210/US\$105.00/£70. A. A. Balkema, P.O.Box 1675, Rotterdam, Netherlands.

Rock mass index

- Bieniawski, Z. T. (1973). Engineering Classification of Jointed Rock Masses. *Trans. S. African Instn. Civil Engrs.*, **Vol. 15, No. 12**, pp. 335-344.
- Franklin, J. A., Broch, E. and Walton, G. (1970). Logging the Mechanical Character of Rock, *Trans. Inst. Min. Metall.*, **A 80**, A1-A9
- Hoek, E. and Brown, E. T. (1980). *Underground Excavations in Rock*, Institution of Mining and Metallurgy, London, 527 pp.
- Hoek, E. and Brown, E. T. (1988). The Hoek-Brown Failure Criterion - A 1988 Update, *15th Canadian Rock Mechanics Sym.*, pp. 31-38
- Hoek, E., Wood, D. and Shah, S. (1992). A Modified Hoek-Brown Failure Criterion for Jointed Rock Masses, *Int. Conf. Eurock '92*, London, pp. 209-214.
- Matula, M. and Holzer, R. (1978). Engineering Topology of Rock Masses, *Proc. of Felsmekanik Kolloquium, Grundlagen und Anwendung der Felsmekanik*, Karlsruhe, pp. 107-121.
- Palmstrom, A. (1995). Characterising the Strength of Rock Masses for Use in Design of Underground Structures, *Conf. Design and Construction of Underground Structures*, New Delhi, pp. 43-52.
- Palmstrom, A. (1996). RMI - A System for Characterizing Rock Mass Strength for Use in Rock Engineering, *Jr. Rock Mech. and Tunnelling Technology*, India, **Vol. 1, No.2**, pp. 69-108.
- Piteau, D. R. (1970). Geological Factors Significant to the Stability of Slopes Cut in Rock, *Proc. Symp. on Planning Open Pit Mines*, Johannesburg, pp. 33-53.
- Tsoutrelis, C.E., Exadatylos, G. E. and Kapanis, A.P. (1990). Study of the Rock Mass Discontinuity System Using Photoanalysis. *Proc. Symp. on Mechanics of Jointed and Faulted Rock*, pp. 103-112.
- Wagner, H. (1987). Design and Support of Underground Excavations in Highly Stressed Rock, *Proc. 6th ISRM Congr.*, **Vol. 3**, Montreal.

CHAPTER - 11

RATE OF TUNNELLING

"Most human beings experience a certain amount of fear when confronted with change. The level varies from moderate dislike to intense hatred. One of the few things stronger than fear of change is love of money. Structure the change so that it provides a potential for profit and the change will happen".

At some point in time the urgings of pundits, the theories of scientists and the calculations of engineers has to be translated into something that the miner can use to drive tunnel better, faster and cheaper. We shall call this change"

Excerpts of the report prepared by Baker, Robert, F. et al.

11.1 Introduction

Excavation of tunnels are affected by many uncertainties. The probable time of completion of tunnelling projects has been grossly underestimated in many cases. This is because proper evaluation of the factors that affect the rate of tunnel excavation is not made. The factors which affect tunnel excavation may be enumerated as -

- (i) variation in ground/job conditions and geological problems encountered,
- (ii) quality of management and managerial problems, and
- (iii) various types of breakdown or hold ups.

The first of these is very important because for different types of ground conditions, the rate of tunnel driving is different. For example, the tunnelling rate is lower in poor ground conditions. Moreover, depending upon the ground conditions, different methods of excavation are adopted for optimum advance per round so that the excavated rock could be supported within the bridge action period or the stand-up time. Frequent changes in ground conditions seriously affects the tunnelling rate because not only the support but also the excavation method needs to be changed. This is perhaps a major reason why use of TBMs has not picked up for tunnelling in the Himalayas where ground conditions change frequently.

The second factor affects the rate of tunnelling differently for different management conditions even in the same type of ground condition. The past experience has been that poor management condition affected tunnelling rate more adversely than poor rock mass condition.

The third factor pertains to the break downs or hold ups during various operations in tunnelling cycle. These hold ups cause delays which are random in nature.

Based on the data collected from many projects, Chauhan (1982) proposed a classification for realistic assessment of rate of tunnelling presented in the following paragraphs.

11.2 Classification of Ground/Job Conditions for Rate of Tunnelling

The rate of tunnelling is seriously affected by the ground conditions. The factors, under the ground condition, affecting the rate of tunnelling are:

- (i) Geology, such as, type of rock, RQD, joint system, dip and strike of strata, presence of major fault or thrust zones and their frequencies and type, and rock mass properties
- (ii) Method of excavation including blast pattern and drilling arrangement,
- (iii) Type of support system and its capacity
- (iv) Inflow of water,
- (v) Presence of inflammable gases,
- (vi) Size and shape of tunnel,
- (vii) Construction adits whether horizontal or inclined, their grade size and length, and
- (viii) High temperature in very deep tunnels ($H > 1000\text{m}$).

On the basis of the above factors affecting the rate of tunnelling, the ground conditions are classified into three categories - good, fair and poor (Table 11.1). It means that for the good ground conditions the rate of tunnelling will be higher and for the poor ground conditions the rate of tunnelling will be lower. The job / ground conditions in Table 11.1 are presented in order of their weightage to rate of tunnelling.

11.3 Classification of Management Conditions for Rate of Tunnelling

The rate of tunnelling may vary in the same ground condition depending upon management quality. The factors affecting management conditions are -

- (i) Overall job planning, including selection of equipment and decision making process,
- (ii) Training of personnel,
- (iii) Equipment availability including parts and preventive maintenance,
- (iv) Operating supervision,
- (v) Incentives to workmen,
- (vi) Co-ordination,
- (vii) Punctuality of staff,
- (viii) Environmental conditions, and
- (ix) Rapport and communication at all levels.

These factors affect the rate of tunnelling both individually and collectively. Each factor is assigned a weighted rating (Table 11.2). The maximum rating possible in each subgroup has also been assigned in Table 11.2 that represents ideal conditions. At a particular site the rating of all the factors is added to obtain a collective classification rating for management condition. Using this rating, the management condition has been classified into good, fair and poor as shown in Table 11.3.

It may be noted that the rate of tunnelling can be easily improved by improving the management condition which is manageable unlike the ground conditions which cannot be changed. So, it is necessary to pay atleast equal, if not more, attention to the management

Rock Mass Classification: A Practical Approach in Civil Engineering

condition than to the ground condition. Hence, there is an urgent need for management consultancy for improving tunnelling rate.

TABLE 11.1
CLASSIFICATION OF GROUND / JOB CONDITION (CHAUHAN, 1982)

| S. No. | Parameter | Job Conditions | | |
|--------|---|---|---|---|
| | | Good | Fair | Poor |
| 1. | Geologic structure | Hard, intact, massive stratified or schistose, moderately jointed, blocky and seamy | Very blocky and seamy squeezing at moderate depth | Completely crushed, swelling and squeezing at great depth |
| 2 (a). | Point load strength index | >2 MPa | 1 - 2 MPa | Index cannot be determined but is usually less than 1 MPa |
| (b) | Uniaxial compressive strength | >44 MPa | 22 - 44 MPa | <22 MPa |
| 3. | Contact zones | Fair to good or poor to good rocks | Good to fair or poor to fair rocks | Good to poor or fair to poor rocks |
| 4. | Rock quality designation (RQD) | 60 - 100 % | 25 - 60 % | <25 % |
| 5.(a) | Joint formation | Moderately jointed to massive | Closely jointed | Very closely jointed |
| (b) | Joint spacing | >0.2 m | 0.05 - 0.2 m | <0.05 m |
| 6.(a) | Joint orientation | Very favourable, favourable and fair | Unfavourable | Very unfavourable |
| (b) | Strike of tunnel axis & dip w.r.t. tunnel driving | (i) Perpendicular 20 to 90° along dip 45 to 90° against dip | (i) Perpendicular 20 to 45° against dip | (i) Parallel 45 to 90° |
| | | (ii) Parallel 20 to 45° | (ii) Irrespective of strike 0 to 20° | -- |
| 7. | Inflammable gases | Not present | Not present | May be present |
| 8. | Water inflow | None to slight | Moderate | Heavy |
| 9. | Normal drilling depth/round | >2.5 m | 1.2 m - 2.5 m | <1.2 m |
| 10. | Bridge action period | >36 hrs | 8 - 36 hrs | <8 hrs |

Note: The geologist's predictions based on investigation data and laboratory and site tests include information on parameters at S. Nos. 1 to 6. This information is considered adequate for classifying the job conditions.

Rate of tunnelling

TABLE 11.2
RATINGS FOR MANAGEMENT FACTORS (CHAUHAN, 1982)

| S. No | Sub-Group | Item | Maximum Rating for | | Remarks for Improvement in Management Condition |
|-------|---|--|--------------------|-----------|--|
| | | | Item | Sub-group | |
| 1 | 2 | 3 | 4 | 5 | 6 |
| 1. | Overall job planning | i) Selection of construction plant and equipment including estimation of optimal size and number of machines required for achieving ideal progress | 7 | 26 | Horizontal adits sloping at the rate of 7% towards portal to be preferred to inclined adits or vertical shafts |
| | | ii) Adoption of correct drilling pattern and use of proper electric delays | 6 | | |
| | | iii) Estimation and deployment of requisite number of workmen and supervisors for ideal progress | 5 | | |
| | | iv) Judicious selection of construction method, adits, location of portals, etc. | 4 | | |
| | | v) Use of twin rail track | 2 | | |
| | | vi) Timely shifting of California switch at the heading | 2 | | |
| 2. | Training of personnel | i) Skill of drilling crew in the correct holding, alignment and thrust application on drilling machines | 4 | 15 | Proper control of drilling and blasting will ensure high percentage of advance from the given drilling depth and also good fragmentation of rock which facilitates mucking operation |
| | | ii) Skill of muck loader operator | 4 | | |
| | | iii) Skill of crew in support erection | 3 | | A skilled crew should not take more than 12 hr for erection of one set of steel rib support |
| | | iv) Skill of blastman | 2 | | |
| | | v) Skill of other crews | 2 | | |
| 3. | Equipment availability and preventive maintenance | Time lost in tunnelling cycle due to breakdowns of equipment including derailments, etc. | | 15 | |
| | | i) upto 1 hr. | 12-15 | | |
| | | ii) 1-2 hrs. | 9-11 | | |
| | | iii) 2-3 hrs. | 6-8 | | |
| | iv) > 3 hrs. | 0-5 | | | |

TABLE 11.2 (Continued)

| | | | | | | |
|----|-----------------------|--|---|--|--|---|
| 4. | Operation supervision | i) Supervision of drilling and blasting (effectiveness depends on location, depth and inclination of drill holes, proper tamping and use of blasting delays) | 7 | 15 | <p>Improper drilling may result in producing:</p> <ul style="list-style-type: none"> i) unequal depth of holes which results in lesser advance per metre of drilling depth, and ii) Wrong alignment of hole which may lead to : <ul style="list-style-type: none"> a) overbreak due to wrong inclination of periphery holes, and b) secondary blasting due to wrong inclination of other than periphery holes <p>Improper tamping of blast hole charge and wrong use of blasting delays result in improper blasting effects</p> | |
| | | ii) Supervision of muck loading / hauling system | 3 | | | <p>Especially in rail haulage system in which rapid feeding of mine cars to loading machine at the heading is essential for increasing productivity of loader</p> |
| | | iii) Supervision of rib erection, blocking and packing | 3 | | | |
| | | iv) Other items of supervision such as scaling, layout, etc. | 2 | | | |
| 5. | Incentive to workmen | i) Progress bonus | 5 | <p>Define the datum monthly progress as that value which delineates good and fair management conditions for a particular job conditions. Introduce bonus slabs for every additional 5 m progress and distribute the total monthly bonus thus earned amongst the workmen on the basis of their importance, skill and number of days worked during the month. The amount for each slab should be so fixed that these are progressive and each worker should get about 50% of his monthly salary as progress bonus. if ideal monthly progress is achieved</p> | | |

Rate of tunnelling

TABLE 11.2 (Continued)

| | | | | | |
|----|--|---|-----|---|--|
| | | ii) Incentive bonus | 2 | 9 | This should be given for certain difficult and hazardous manual operations like rib erection - shear zone treatment, etc. |
| | | iii) Performance bonus | 1 | | This should be given to the entire tunnel crew equally if the quarterly progress target is achieved |
| | | iv) Achievement bonus | 1 | | It is to be given for completion of whole project on schedule. It should be given to the whole construction crew and may be equal to one year's interest on capital cost |
| 6. | Co-ordination | i) Co-ordination of activities of various crews inside the tunnel | 5 | 9 | |
| | | ii) Use of CPM for overall perspective and control of the whole job | 4 | | |
| 7. | Environmental conditions and house keeping | Proper lighting, dewatering, ventilation, provision of safety wear to workmen and general job cleanliness | 4 | 4 | |
| 8. | Punctuality of staff | i) Prompt shift change-over at the heading | 4 | 4 | |
| | | ii) Loss of upto 1/3 hr. in shift change-over | 3 | | |
| | | iii) Loss of more than 1/3 hr. in shift change-over | 0-2 | | |
| 9. | Rapport and communication | Good rapport and communication at all levels of working including top management and government level including human relations | 3 | 3 | Team spirit is the key to success in underground construction |

TABLE 11.3
RATING FOR DIFFERENT MANAGEMENT CONDITIONS
(CHAUHAN, 1982)

| S. No. | Management Condition | Rating |
|--------|----------------------|----------|
| 1. | Good | 80 - 100 |
| 2. | Fair | 51 - 79 |
| 3. | Poor | ≤50 |

TABLE 11.4
GROUND AND MANAGEMENT FACTORS
(CHAUHAN, 1982)

| Ground Conditions | Management Conditions | | |
|-------------------|-----------------------|------|------|
| | Good | Fair | Poor |
| Good | 0.78 | 0.60 | 0.44 |
| Fair | 0.53 | 0.32 | 0.18 |
| Poor | 0.30 | 0.21 | 0.13 |

11.4 Combined Effect of Ground and Management Conditions on Rate of Tunnelling

A combined classification system for ground conditions and management conditions has been developed by Chauhan (1982). Each of the three ground conditions has been divided into three management conditions and thus nine categories have been obtained considering both ground and management conditions. The field data of 6 tunnelling projects in the Indian Himalayas have been divided into these nine categories for studying the combined effect. Each category has three performance parameters which are-

- (i) Actual working time (AWT),
- (ii) Break down time (BDT), and
- (iii) Advance per round (APR).

A matrix of job and management factors has been developed from the data for evaluating tunnel advance rate as given in Table 11.4.

Ground and management factors in the matrix are defined as a ratio of actual monthly progress to achievable monthly progress under corresponding set of ground and management conditions. Knowing the achievable production for a tunnelling project, these factors could hopefully yield values of expected production under different management conditions on the project.

Thus, in squeezing ground conditions, the rate of tunnelling would be only 13 percent of the theoretical rate for poor management condition. Past experience suggests that management tends to relax in good tunnelling conditions and becomes alert and active in poor rock conditions. Young engineers love challenging works. There should be no hesitation in throwing challenges to young engineers. Otherwise these young engineers may loose interest in routine management.

Further studies are needed to update Table 11.2 to 11.4 for modern tunnelling technology. Trends are expected to be similar.

Management of World Bank funded projects is an ideal example. They appoint international experts on Rock Mechanics on their hydroelectric projects. In major state funded projects,

international experts on Rock Mechanics should be appointed on the Board of Consultants as in the past. The international experts help achieve self-reliance.

References

- Barton, N., Lien, R. and Lunde, J. (1974). Engineering Classification of Rock Masses for the Design of Tunnel Supports, *Rock Mech.*, Springer-Verlag, **Vol. 6, No. 4**, pp. 189-236.
- Bieniawski, Z. T. (1973). Engineering Classification of Jointed Rock Masses, *Trans. S. Afr. Inst. Civil Engrs.*, **Vol.15**, pp. 335-342.
- Bieniawski, Z. T. (1974). Geomechanics Classification of Rock Masses and its Application in Tunnelling, *Proc. 3rd Int. Cong. Rock Mech.*, ISRM, Denver, VIIA, pp. 27-32.
- Chauhan, R. L. (1982). A Simulation Study of Tunnel Excavation, *Ph. D. Thesis, University of Roorkee, India*.
- Deere, D. U. (1964). Technical Description of Rock Cores for Engineering Purpose, *Rock Mech. and Engg. Geology*, Vol. 1, No.1, pp. 17-22.
- Deere, D. U. and Miller, R. P. (1966). Engineering Classification and Index Properties for Intact Rock, *Technical Report No. AFNL-TR-116*, AIR Force Weapons Laboratory, Kirtland AFB, New Mexico.
- Lauffer, H. (1958). Gebirgsklassifizierung Fur den Stollenbau, *Geologie and Bauwesen*, **Vol. 24, No. 1**, pp. 46-51.
- Terzaghi, K. (1946). *Rock Defects and Load on Tunnel Supports - Introduction to Rock Tunnelling with Steel Supports*, Ed. Proctor, R. V. and White T. L., Commercial Shearing and Stamping Co., Youngstown, Ohio, USA, pp. 278.

CHAPTER - 12

SUPPORT SYSTEM IN CAVERNS

"I believe that the engineer needs primarily the fundamentals of mathematical analysis and sound methods of approximation"

Th. Von Karman

12.1 Support Pressure

Large underground openings are called caverns. Caverns are generally sited in good rock masses where the rocks are massive, dry and the ground condition would be either the self-supporting or the non-squeezing.

It has been experienced that for assessment of roof and wall support pressures the approaches discussed in Chapter 8 are reliable and can be adopted. The approach of Goel et al. (1995) in Chapter 9, has been developed for tunnels with diameter up to 12 m and therefore, its applicability for caverns with diameter more than 12 m is yet to be evaluated. Modified Terzaghi's theory of Singh et al. (1995), as discussed in chapter 5, may also be used confidently for estimating the roof support pressures.

The 3D finite element analysis of power house cavern of Sardar Sarovar Hydroelectric Project, India suggests that wall support pressures are very small than the roof support pressures as the stiffness of wall shotcrete is very low than that of roof shotcrete. The value of p_{wall} away from the shear zone is about 0.07 to 0.11 p_{roof} , whereas in the area of 2 m wide shear zone p_{wall} is about 0.20 to 0.50 p_{roof} . The predicted support pressures in roof away from the shear zone and near the shear zone are approximately equal to the empirical ultimate support pressures for surrounding rock mass quality and mean value of rock mass quality respectively (Samadhiya, 1998) as discussed in Art. 2.2 of Chapter 2.

Roof support requirements (including bolt length and their spacing) can be estimated from the empirical approaches of Cording et al. (1971), U. S. Corps of Engineers (1980), Hoek and Brown (1980), Barton et al. (1980) and Barton (1998). These approaches are based on the thumb rules and do not take care of the rock mass type and the support pressure for designing the bolt length. It is pertinent to note that none of these approaches except Barton's method and modified Terzaghi's theory of Singh et al. (1995) provide a criterion for estimating the support pressure for caverns also.

The philosophy of rock reinforcement is to stitch rock wedges together and restrain them from sliding down both from the roof and the walls. Experience has shown that the empirical approaches based on rock mass classifications provide realistic bolt lengths, in cases of weak zones, when compared with the results of the numerical analysis. In view of this, Singh et al. (1995) have presented the following approach of designing anchors / rock bolts for cavern

walls in non-squeezing ground conditions. Park et al. (1997) used this design concept for four food storage caverns in Korea. The simple software package, TM, based on this approach may be used for design of support systems for walls and roof. It has been used successfully at Ganwi mini hydel project in H.P., India. Program TM can also be used for tunnels in both non-squeezing and squeezing ground conditions.

12.2 Wall Support in Caverns

It may be noted that the reinforced rock wall column ($L > 15\text{m}$) has a tendency to buckle under tangential stress (Bazant et al., 1993) due to the possibility of vertical crack propagation behind the reinforced rock wall (Figure 12.1). The length of anchors / rock bolts should therefore be adequate to prevent buckling of rock wall column and hence the vertical crack propagation. Thus, equating the buckling strength of the reinforced rock column (assuming both ends are fixed) and the average vertical (tangential) stress on the haunches along the bolt length, one obtains

$$\frac{l'_w}{L} > \left[\frac{F_{\text{wall}} \times 12 \sigma_\theta}{4 \times \pi^2 E_d} \right]^{1/2} \quad (12.1)$$

$$l_w = l'_w + \frac{\text{FAL}}{2} + \frac{s_{\text{bolt}}}{4} - s_{\text{rock}} + d \quad (12.2)$$

where,

σ_θ = effective average tangential stress on haunches,

\approx 1.5 x overburden pressure,

l_w = length of bolts/anchors in wall,

l'_w = effective thickness of reinforced rock column ($l_w \geq l'_w$),

d = depth of damage of rock mass due to blasting (1-3m),

E_d = modulus of deformation of reinforced rock mass which may be taken to be approximately equal to modulus of deformation of natural rock mass

$$= 0.3 H^\alpha 10^{(\text{RMR}-20)/38} \text{ GPa (Verman, 1993)} \quad (12.3)$$

$$= H^{0.2} \cdot Q^{0.36} \text{ GPa for } Q < 10 \text{ (Singh et al., 1998)} \quad (12.4)$$

α = 0.16 to 0.30 (more for weak rocks),

F_{wall} = mobilization factor for buckling,

$$F_{\text{wall}} = 3.25 p_{\text{wall}}^{0.10} \text{ (for pretensioned bolts),} \quad (12.5)$$

$$= 9.5 p_{\text{wall}}^{-0.35} \text{ (for anchors),} \quad (12.6)$$

FAL = fixed anchor length of anchor to give pull out capacity p_{bolt} higher for poor rocks,

s_{bolt} = spacing of bolts/anchors,

= square root of area of rock mass supported by one bolt, and

s_{rock} = average spacing of joints in rock mass.

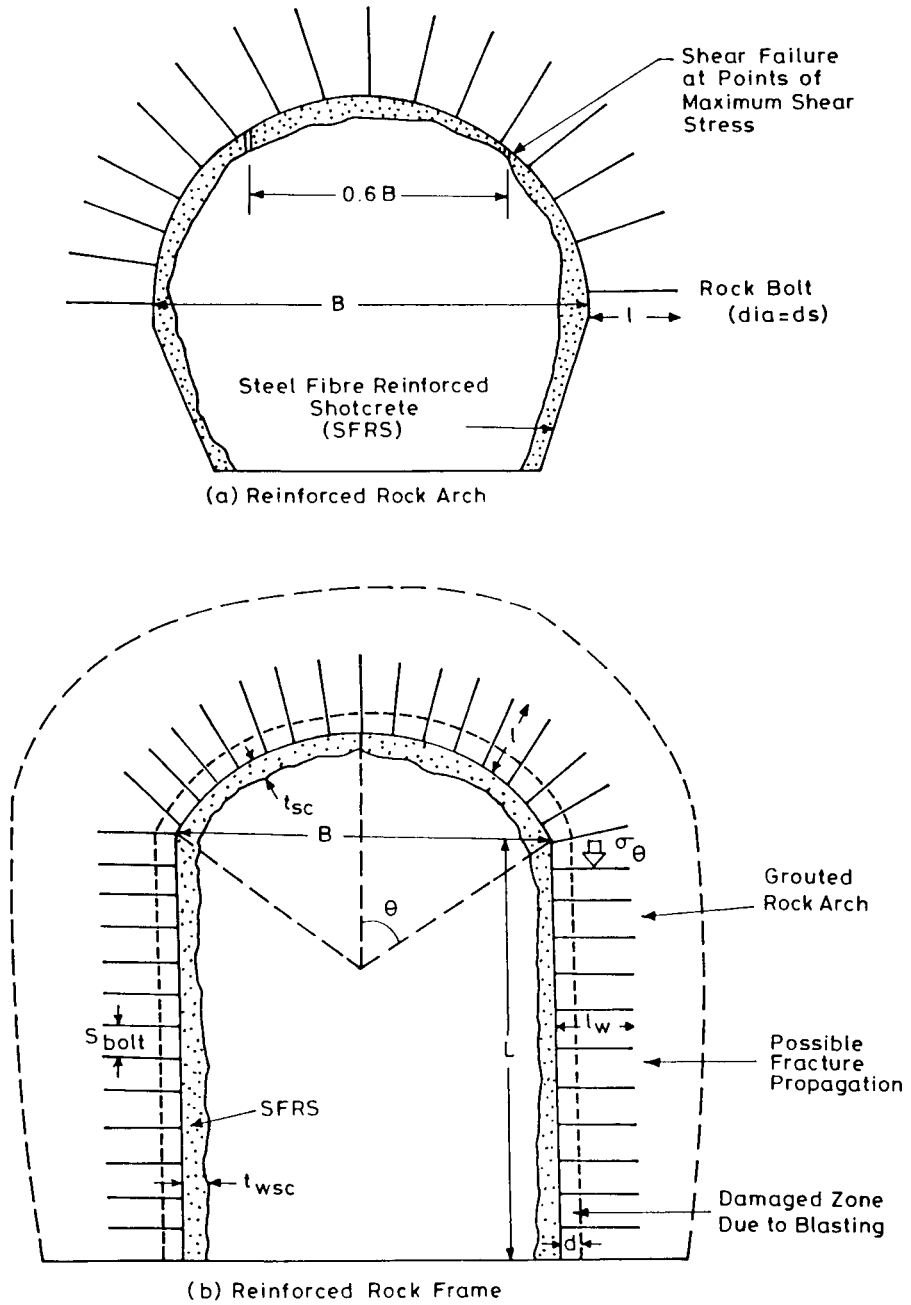

Figure 12.1: Design of support system for underground openings

Singh, Fairhurst and Christiano (1973), with the help of a computer model, showed that the ratio of the moment of inertia of bolted layers to that of unbolted layers increases with both decrease in thickness and the modulus of deformation of rock layers. The experiments of Fairhurst and Singh (1974) also confirmed this prediction for ductile layers. The mobilizing factor for anchors (Eqn. 12.6) simulates this tendency empirically as F_{wall} decreases with decrease in rock mass quality and p_{wall} . In other words, rock anchors are more effective than pre-tensioned bolts in poor rock masses, as strains in both the rock mass and the anchors are higher in poor rocks.

Further, it is recommended that the same length of bolts should be used in the roof as used in the walls, since the tangential force from the roof - arch will also be transmitted to the rock wall column.

Thus, stability of reinforced haunches is ensured automatically because of the presence of a critically oriented joint. If steel ribs have been used to support the roof, additional reinforcement of haunches is required. (Failure of haunches due to heavy thrust of the steel ribs has been observed in caverns and larger tunnels in poor rock conditions). Furthermore the thickness of shotcrete should be checked for shearing failure as follows:

$$u_w + p_{wall} \leq \frac{2 q_{sc} \cdot t_{wsc}}{L \cdot F_{wsc}} \quad (12.7)$$

where,

- p_{wall} = ultimate wall support pressure (t/m^2),
 - = 0.28 p_{roof} near major shear zones,
 - = 0.09 p_{roof} in caverns,
- u_w = average seepage pressure in wall (t/m^2),
 - = 0 in case of grouted rock column,
- t_{wsc} = thickness of shotcrete or steel fibre reinforced shotcrete (SFRS) in wall
- F_{wsc} = mobilization factor for shotcrete in wall,
 - $\cong 0.60 \pm 0.05$
- q_{sc} = shear strength of shotcrete = $300 t/m^2$,
 - = shear strength of SFRS = $550 t/m^2$.

In the above equation, the support capacity of wall rock bolts is not accounted for, as they are preventing the buckling of the wall columns of the rock mass. If longer bolts are provided in the walls, lesser thickness of shotcrete may be recommended on the basis of past experience. Further, research is needed to improve Eqn. 12.7 which is conservative.

12.3 Roof Support in Caverns

The recommended angle θ between the vertical and the spring point (Figure 12.1b) is given by,

$$\sin\theta = \frac{1.3}{B^{0.16}} \quad (12.8)$$

where B is the width of the roof arch in metres.

The ultimate roof support capacity is given by a semi-empirical theory (Singh et al., 1995) for both tunnels and caverns,

$$P_{ult} + u = P_{sc} + P_{bolt} \quad (12.9)$$

where,

$$\begin{aligned} P_{ult} &= \text{ultimate support pressure from Eqn. 8.10 } (f' = 1) \text{ in } t/m^2, \\ u &= \text{seepage pressure roof rock after commissioning of the hydroelectric} \\ &= \text{project in } t/m^2, \\ &= 0 \text{ in nearly dry rock mass, and} \\ P_{sc} &= \text{support capacity of shotcrete/SFRS in } t/m^2, \\ &= \frac{2 t_{sc} \cdot q_{sc}}{F_{sc} \cdot B} \end{aligned} \quad (12.10)$$

$$\begin{aligned} F_{sc} &= 0.6 \pm 0.05 \text{ (higher for caverns)} \\ F_{sc} \cdot B &= \text{horizontal distance between vertical planes of maximum shear stress in} \\ &= \text{the shotcrete in the roof,} \end{aligned}$$

$$P_{bolt} = \frac{2 \cdot l' \cdot q_{cmrb} \cdot \sin\theta}{F_s \cdot B} \quad (12.11)$$

$$\begin{aligned} q_{cmrb} &= \text{uniaxial compressive strength of reinforced rock mass in } t/m^2, \\ &= \left[\frac{P_{bolt}}{2 s_{bolt}} - u \right] \cdot \frac{1 + \sin\phi_j}{1 - \sin\phi_j} > 0 \end{aligned} \quad (12.12)$$

$$\begin{aligned} P_{bolt} &= \text{capacity of each rock anchor / bolt tension in } t/m^2, \\ s_{bolt} &= \text{spacing of rock bolts / anchors in metre,} \\ l' &= 1 + \frac{FAL}{2} + \frac{s_{bolt}}{4} - s_{rock} \end{aligned} \quad (12.13)$$

$$\begin{aligned} \tan\phi_j &= \frac{J_r}{J_a} < 1.5 \\ &= J_{rm}/J_{am} \text{ near shear zones} \end{aligned} \quad (12.14)$$

$$\begin{aligned} F_s &= \text{mobilization factor for rock bolts,} \\ &= 3.25 P_{ult}^{0.10} \text{ for pretension bolts,} \\ &= 9.5 P_{ult}^{-0.35} \text{ for rock anchors and full-column grouted rock bolts,} \\ J_{rm} &= \text{mean joint roughness number near shear zone (Art. 2.2), and} \\ J_{am} &= \text{mean joint alteration number near shear zone (Art. 2.2).} \end{aligned}$$

These mobilization factors have been back-analysed from tables of support system of Barton et al. (1974) and the chart for SFRS (Figure 8.8). Later, Thakur (1995) confirmed the above design criteria from 120 case histories. Alternatively, Figure 8.8 may be used for selection of steel fibre reinforced shotcrete support system in the feasibility design.

At the detailed design stage, UDEC & 3DEC software packages are recommended for a rational design of support system and finding out of the best sequence of excavation to restrain progressive failure of rock mass. It may be noted that the maximum tensile stress occurs at junctions of openings. Tensile stresses also exist in the roof and the walls. Hence the need for proper study to ensure that the rock mass is adequately reinforced to take care of critical tensile stresses.

12.4 Stress Distribution in Caverns

Stress distribution should be studied carefully. The 2D stress analysis of deep cavern of Tehri Dam Project, India shows that the stress concentration factor ($\sigma_0/\gamma \cdot H$) at haunch is about 2.5 initially and decreases to about 1.5 when the cavern is excavated down below the haunches to the bottom of the cavern. The 3D stress analysis of shallow cavern of Sardar Sarovar Project, India shows that final stress concentration factor at haunch is about 1.1 only (Samadhiya, 1998). In both the cases the extent of distressed zone goes beyond $2L$ as the low shear stiffness of joints does not allow high shear stresses in the rock mass. The 3D distribution of shear stresses in the shotcrete at Sardar Sarovar Project suggests that the horizontal distance between vertical planes of maximum shear stresses is $B \cdot F_{sc}$, where F_{sc} is about 0.60 ± 0.05 (Singh et al., 1995).

12.5 Opening of Discontinuities in Roof Due to Tensile Stress

In Himalayan region, thin bands of weak rocks are found within good rock masses. Sometimes these thin bands are just above the roof. Separation between a stronger rock mass above and the weak bands below it takes place where tensile stress is more than the tensile strength (q_{ij}) of the weak band. As such, longer rock bolts are needed soon after excavation to stop this separation and for stabilize the roof. Thus, tensile strength q_{ij} need to be estimated for the minimum value of Q in the band and the adjoining rock mass (Chapter 13 and Eqn. 13.17).

12.6 Rock Reinforcement Near Intersections

In mine roadways, Tincelin (1970) recommended 25 per cent increase in the length of rock bolts near intersections. In the case of caverns, the length of rock bolts for both, wall of the cavern and an intersecting tunnel, may be increased by about 35 per cent in the vicinity of intersections with the tunnels, so as the rock mass in tension is reinforced effectively.

12.7 Radial Displacements

On the basis of a large number of case histories, Barton (1998) found the following approximate correlations for absolute radial displacement δ in the crown of roof and centre of wall away from shear zone/weak zones (for $B/Q = 0.5$ to 250),

$$\delta_v = \frac{B}{100 Q} \sqrt{\frac{\sigma_v}{q_c}} \quad (12.15)$$

$$\delta_h = \frac{H_t}{100 Q} \sqrt{\frac{\sigma_h}{q_c}} \quad (12.16)$$

where,

- δ_v, δ_h = radial displacement in roof and wall respectively,
- σ_v, σ_h = insitu vertical stress and horizontal stress normal to the wall of cavern respectively,
- B = span of the cavern,
- H_t = total height of the cavern,
- Q = average rock mass quality, and
- q_c = uniaxial compressive strength of rock material.

12.8 Precautions

- (i) For tunnels, $\theta = 90^\circ$
- (ii) The directional rock bolts should be designed for tackling loads due to wheels of crane on the haunches.
- (iii) Support must be installed within stand-up time (Figure 6.1).

While adopting the empirical approaches, it must be ensured that the ratings for the joint sets, joint spacing, RQD, etc. should be scaled down for the caverns, if initially ratings are obtained from the drifts, because there are chances of missing a few joint sets and weak intrusions in a drift. The rock mass quality should be down-graded in the area of a shear zone and a weak zone (Art. 2.2, Chapter 2). A mean value of deformation modulus E_m should be substituted for E_d in Eqn. 12.1 for estimating the length of wall anchors. Similarly, a mean value of rock mass quality Q_m and joint roughness number J_{rm} should be used in Eqn. 8.10 for assessment of the ultimate support pressure.

Stresses in the shotcrete lining and the rock anchors may be reduced significantly by delaying subsequent layers of shotcrete, except initial layers, but not later than the stand-up time.

Instrumentation for the measurements of stress and deformation in the roof and the walls of a cavern or for that matter in tunnels is a must to ensure the safe support system. Instrumentation would also provide feed back for improvements in the designs of such future projects. Location of instrumentation should be judiciously selected depending upon the weak zones, the rock mass quality, and intersection of openings.

References

- Barton, N. (1998). Quantitative Description of Rock Masses for the Design of NMT Reinforcement, *Int. Conf. on Hydropower Development in Himalayas*, Shimla, pp. 379-400.
- Barton, N., Loset, F., Lien, R. and Lune, J. (1980). Application of Q-system in Design Decisions Concerning Dimensions and Appropriate Support for Underground Installation, *Subsurface Space*, Pergamon, pp. 553 - 561.
- Bazant, Z. P., Lin, F. B. and Lippman, H. (1973). Fracture Energy Release and Size Effect on Borehole Breakout, *Int. J. Numerical and Analytical Methods in Geomech.*, John Wiley, **Vol. 17**, pp. 1-14.
- Cording, E. J., Hendron, A. J. and Deere, D. U. (1971). Rock Engineering for Underground Caverns, *Symposium on Underground Chambers*, ASCE, Phoenix, Arizona, pp. 567-600.
- Fairhurst, C. and Singh, B. (1974). Roof Bolting in Horizontally Laminated Mine Roof, *Engineering and Mining Jour.*, pp. 80-90.
- Goel, R. K., Jethwa, J. L. and Paithankar, A. G. (1995). Indian Experiences with Q and RMR systems, *Jr. Tunnelling and Underground Space Technology*, Pergamon, **Vol. 10, No. 1**, pp. 97-109.
- Hock, E. and Brown, E. T. (1980). *Underground Excavations in Rock*, Institution of Mining and Metallurgy, London.
- Park, E. S., Kim, H. Y. and Lee, H. K. (1997). A Study on the Design of the Shallow Large Rock Cavern in the Gonjiam Underground Storage Terminal, *Proc. 1st Asian Rock Mechanics Symposium on Environmental & Strategy Concerns in Underground Construction*, Seoul, pp. 345-351.
- Samadhiya, N. K. (1998). Influence of Shear Zone on Stability of Cavern, *Ph. D. Thesis, Dept. of Civil Engineering, University of Roorkee*, p. 334.
- Singh, Bhawani., Fairhurst, C. and Christiano, P. P. (1973). Computer Simulation of Laminated Roof Reinforced with Grouted Bolt. *Proc. of IGS Sym. on Rock Mech. and Tunnelling Problems*, Kurukshetra, India, pp. 41-47.
- Singh, Bhawani., Goel, R. K., Mehrotra, V. K., Garg, S. K. and Allu, M. R. (1998). Effect of Intermediate Principal Stress on Strength of Anisotropic Rock Mass, *Jr. Tunnelling and Underground Space Technology*, Pergamon, **Vol. 13**, No.1, pp. 71-79.
- Singh, Bhawani., Jethwa, J. L. and Dube, A. K. (1995). Modified Terzaghi's Rock Load Concept for Tunnels, *Jr. Rock Mech. & Tunnelling Technology*, **Vol. 1, No. 1**, India.
- Singh, Bhawani., Viladkar, M. N., Samadhiya, N. K. and Sandeep (1995). A Semi-empirical Method of the Design of Support Systems in Underground Openings. *Jr. Tunnelling and Underground Space Technology*, Pergamon, **Vol. 3**, pp. 375-383.
- Thakur, B. (1995). Semi-empirical Method for Design of Supports in Underground Excavations, *M. E. Thesis, University of Roorkee*, India, p. 126.
- Verman, Manoj (1993). Rock Mass-Tunnel Support Interaction Analysis, *Ph. D. Thesis, University of Roorkee*, India.
- Tincelin, E. (1970). Roof Bolting Recommendations, Parley of Cooperation and Industrial Promotion for Exploration and Exploitation of Mineral Deposits and Mineral Processing, Sydney.

CHAPTER - 13

STRENGTH ENHANCEMENT OF ROCK MASS IN TUNNELS

"The behaviour of macroscopic systems is generally described by non-linear laws. The non-linear laws may explain irreversible phenomena like instabilities, dualism, unevolving societies, cycles of growth and decay of societies. The linear laws are only linear approximation of the non-linear laws at a point in time and space"

Ilya Prigogine, Nobel Laureate

13.1 Causes of Strength Enhancement

Instrumentation and monitoring of underground openings in complex geological environment is the key to success. Careful back analysis of the data observed in the initial stages of excavation provides valuable knowledge of the constants of the selected constitutive model which may then be used in the forward analysis to predict performance of the support system. Experience of back analysis of data from many project sites has shown that there is a significant enhancement of rock mass strength around tunnels. Rock masses surrounding the tunnel perform much better than theoretical expectations, except near thick and plastic shear zones, faults, thrusts, intra-thrust zones and in water charged rock masses.

Rock masses have shown constrained dilatancy in tunnels. Failure, therefore, does not occur along rough joints due to interlocking. Further, tightly packed rock blocks are not free to rotate unlike soil grains. The strength of a rock mass in tunnels thus tends to be equal to the strength of a rock material (Pande, 1997).

It has been seen that empirical rock mass failure criteria are trusted more than the theoretical criteria. Sheorey (1997) evaluated them critically. However, designers like the linear approximation for practical applications.

13.2 Effect of Intermediate Principal Stress on Tangential Stress at Failure in Tunnels

The intermediate principal stress (σ_2) along the tunnel axis may be of the order of half the tangential stress (σ_1) in some deep tunnels (Figure 13.1). According to Wang and Kemeny (1995), σ_2 has a strong effect on σ_1 at failure even if σ_3 is equal to zero. Their polyaxial laboratory tests on hollow cylinders led to the following strength criterion:

$$\frac{\sigma_1}{q_c} = 1 + A[e^{\sigma_3/\sigma_2}], \left[\frac{\sigma_2}{q_c}\right]^{1-f} \cdot e^{(\sigma_3/\sigma_2)} \quad (13.1)$$

Strength enhancement of rock mass in tunnels

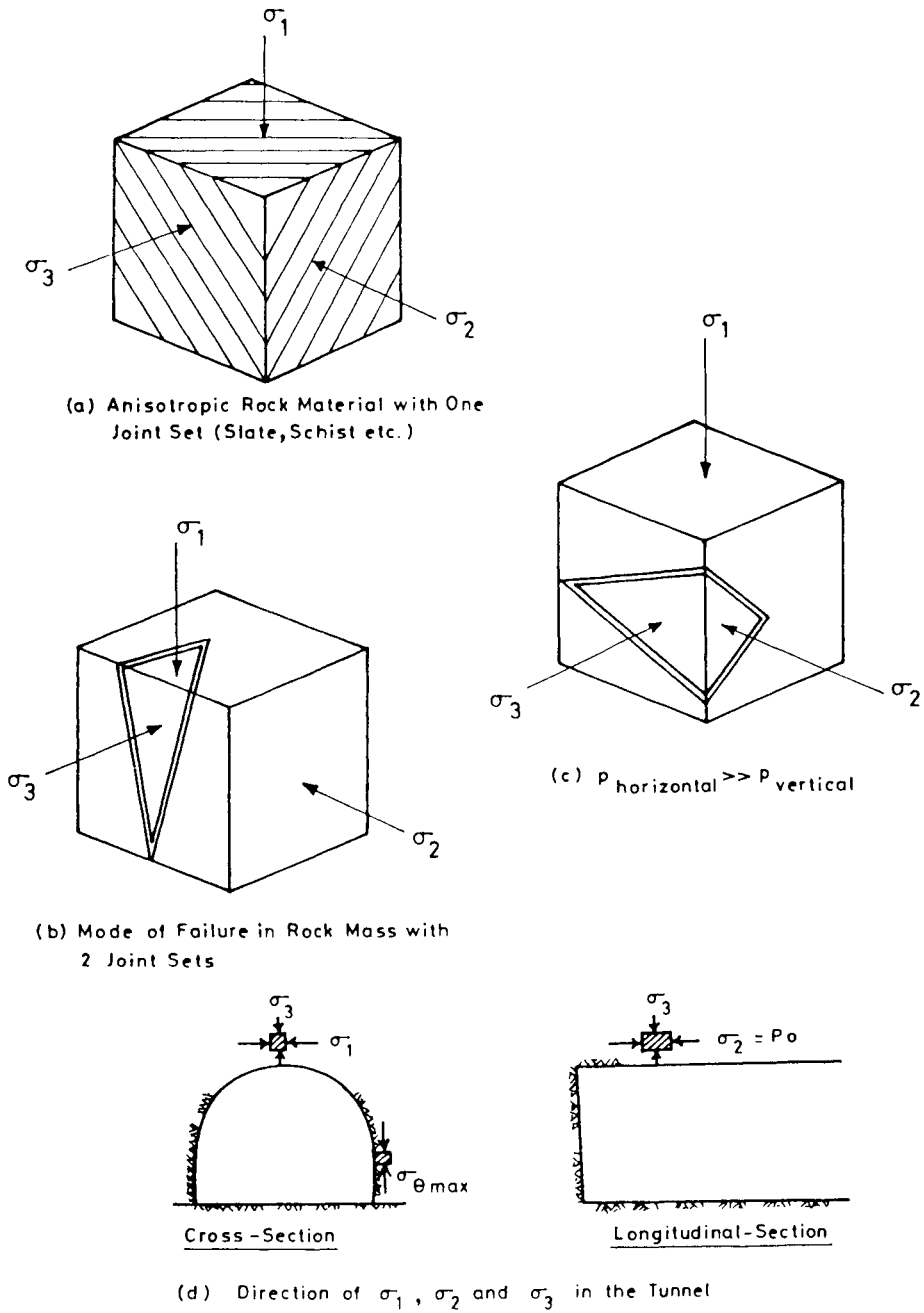

Figure 13.1

$$\therefore \sigma_1 \approx q_c + (A + f) \cdot (\sigma_3 + \sigma_2) \quad \text{for } \sigma_3 \ll \sigma_2$$

where,

- f = material constant (0.10 - 0.20),
- A = material constant (0.75 - 2.00), and
- q_c = average uniaxial compressive strength of rock material ($\sigma_2 = \sigma_3 = 0$) for various orientations of planes of weakness

In the case of unsupported tunnels, $\sigma_3 = 0$ on its periphery. So, Eqn. 13.1 simplifies to,

$$\frac{\sigma_1}{q_c} = 1 + A \left[\frac{\sigma_2}{q_c} \right]^{(1+f)} \quad (13.2)$$

It may be inferred from Eqn. 13.2 that σ_2 will enhance σ_1 at failure by 75-200 per cent when $\sigma_2 \approx q_c$. In fact, strength enhancement may be much more as propagation of fracture will be behind the excavated face (Bazant et al., 1993). Murrell (1963) suggested 100 percent increase in σ_1 at failure when $\sigma_2 = 0.5 \sigma_1$ and $\sigma_3 = 0$. Thus, the effective confining pressure appears to be an average of σ_2 and σ_3 and not just equal to σ_3 in the anisotropic rocks and weak rock masses.

Hoek (1994) suggested the following modified criterion for estimating the strength of jointed rock masses at high confining stresses (say around $\sigma_3 > 0.10 q_c$),

$$\sigma_1 = \sigma_3 + q_c \left[m \left(\frac{\sigma_3}{q_c} \right) + s \right]^n \quad (13.3)$$

where,

- σ_1 & σ_3 = maximum and minimum effective principal stresses respectively,
- m = Hoek-Brown rock mass constant,
- s & n = rock mass constants,
- s = 1 for rock material,
- n = 0.5
- = 0.65 - (GSI/200) \leq 0.60 for GSI < 25,
- q_c = UCS of the intact rock core of standard NX size,
- GSI = geological strength index \approx RMR - 5 for RMR > 23 (Chapter 25),
- (m/m_r) = s^{1/3} for GSI > 25, and
- m_r = Hoek - Brown rock material constant.

Hoek and Brown (1980) criterion (Eqn. 13.3) is applicable to rock slopes and open cast mines with weathered and saturated rock mass. They have suggested values of m and s as given by Eqns. 25.7 and 25.8 respectively in Chapter 25. Hoek and Brown criterion may be improved

as a polyaxial criterion after replacing σ_3 (within bracket in Eqn. 13.3) by effective confining pressure $(\sigma_2 + \sigma_3)/2$ as mentioned above for weak and jointed rock masses (Hoek, 1998).

Further, the limitations should be kept in mind that most of the strength criteria are not valid at low confining stresses and tensile stresses, as modes of failure are different. Hoek's criterion is applicable for high confining stresses only where a single mode of failure by faulting takes place. Hence, the quest for a better model to represent jointed rock masses.

13.3 Uniaxial Compressive Strength of Rock Mass

Equation 13.3 defines that uniaxial compressive strength of a rock mass is given by

$$q_{\text{cmass}} = q_c s^n \quad (13.5)$$

Past experience shows that Eqn. 13.5 underestimates mobilized rock mass strength in tunnels. For making use of Eqn. 13.3 in tunnels, value of constant s be obtained from Eqns. 13.5 and 13.8 as follows.

$$s = [(7 \gamma Q^{1/3})/q_c]^{1/n} \quad (13.6)$$

Ramamurthy (1993) and his co-workers (Roy, 1993) have conducted extensive triaxial tests on dry models of jointed rock mass using plaster of Paris ($q_c = 9.46$ MPa). They varied joint frequency, inclination of joints and thickness of joint fillings, etc. and simulated a wide variety of rock mass conditions. Their extensive test data suggests the following approximate correlation for all the rock masses,

$$q_{\text{cmass}}/q_c = [E_{\text{mass}}/E_r]^{0.7} \quad (13.7)$$

where,

- q_{cmass} = uniaxial compressive strength (UCS) of model of jointed rock mass,
- q_c = UCS of model material (plaster of Paris),
- = UCS of insitu block of rock material after size correction as per Eqn. 10.4,
- E_{mass} = average deformation modulus of jointed rock mass model ($\sigma_3 = 0$), and
- E_r = average deformation modulus of model material ($\sigma_3 = 0$).

The power in Eqn. 13.7 varies from 0.5 to 1.0. Griffith's theory of failure suggests that the power is 0.5, whereas Sakurai (1994) is of the opinion that the above power is about 1.0 for jointed rock masses. Further research at Indian Institute of Technology (IIT), Delhi suggests that power in Eqn. 13.7 is in the range of 0.61 and 0.74. As such it appears that the power of 0.7 in Eqn. 13.7 is realistic. Equation 13.7 may be used reliably to estimate uniaxial compressive strength of a rock mass (q_{cmass}) from the values of E_{mass} obtained from uniaxial jacking tests.

Considerable strength enhancement of the rock mass in tunnels has been observed by Singh et al. (1997). Therefore, on the basis analysis of data collected from 60 tunnels, they recommended that the mobilized crushing strength of the rock mass is -

$$q_{c\text{mass}} = 7 \gamma Q^{1/3} \quad \text{MPa} \quad (\text{for } Q < 10, 100 > q_c > 2\text{MPa}, \quad (13.8)$$

$$J_w = 1 \text{ and } J_r / J_a < 0.5)$$

$$q_{c\text{mass}} = [(5.5 \gamma N^{1.3}) / B^{0.1}] \quad \text{MPa} \quad (13.9)$$

where,

- γ = unit weight of rock mass (gm/cc),
- N = rock mass number, i.e., stress free Barton's Q (Chapter 9), and
- B = tunnel span or diameter in metres.

Grimstad and Bhasin (1996) have modified Eqn. 13.8 as Eqn. 13.10 which has been found suitable for good and massive hard rock masses (Singh et al., 1997).

$$q_{c\text{mass}} = 7 \gamma f_c \cdot Q^{1/3} \quad \text{MPa} \quad (\text{for } Q > 10 \text{ and } q_c > 100 \text{ MPa}) \quad (13.10)$$

where,

- f_c = correction factor = $q_c / 100$
- = 1 for $q_c < 100$ MPa

A couple of metal mining case histories in India suggest that Eqns. 13.7 and 13.8 are applicable to hard rock mines also.

On the basis of block shear tests, Singh et al. (1997) have proposed the following correlation for estimating the UCS of the rock mass for use in rock slopes in hilly areas.

$$q_{c\text{mass}} = 0.38 \gamma \cdot Q^{1.3} \quad \text{MPa} \quad (13.11)$$

Equation 13.11 suggests that the UCS would be low on slopes. This is probably because joint orientation becomes a very important factor in the case of slopes due to unconstrained dilatancy and low intermediate principal stress unlike tunnels. Further, failure takes place along joints near slopes. In slopes of deep open cast mines, joints may be tight and of smaller length. The UCS of such a rock mass may be much higher and may be found from Hoek's criterion (Eqn. 13.5) for analysis of the deep seated rotational slides.

The strength parameters Eqns. 13.7 and 13.8 are intended only for a 2D stress analysis of underground openings. The strength criterion for 3D analysis is presented now.

13.4 Reason for Strength Enhancement in Tunnels and A Suggested New Failure Theory

Consider a cube of rock mass with two or more joint sets as shown in Figure 13.1. If high intermediate principal stress is applied on the two opposite faces of the cube, then the chances of wedge failure are more than the chances of planar failure as found in the triaxial tests. The shear stress along the line of intersection of joint planes will be proportional to $\sigma_1 - \sigma_3$ because σ_3 will try to reduce shear stress. The normal stress on both the joint planes will be proportional to $(\sigma_2 + \sigma_3)/2$. Hence the criterion for peak failure at low confining stresses may be as follows:

$$\sigma_1 - \sigma_3 = q_{c\text{mass}} + A [(\sigma_2 + \sigma_3) / 2], \quad (13.12)$$

$$q_{c\text{mass}} = q_c \left[\frac{E_d}{E_r} \right]^{0.70} \cdot \left[\frac{d}{S_{\text{rock}}} \right]^{0.20},$$

$$\Delta = \frac{\phi_p - \phi_r}{2}$$

where,

- $q_{c\text{mass}}$ = average uniaxial compressive strength of rock mass for various orientation of principal stresses,
- $\sigma_1, \sigma_2, \sigma_3$ = final effective principal stresses which are equal to insitu stress plus induced stress minus seepage pressure,
- A = average constants for various orientation of principal stress, (value of A varies from 0.6 to 6.0),
 = $2 \cdot \sin \phi_p / (1 - \sin \phi_p)$,
- ϕ_p = peak angle if internal friction of rock mass,
 $\cong \tan^{-1} (J_r / J_a)$ at a low confining stress,
 < peak angle of internal friction of rock material.
 = $14^\circ - 57^\circ$
- S_{rock} = spacing of joints,
- q_c = average UCS of rock material for core of diameter d (for schistose rock also),
- Δ = peak angle of dilatation of rock mass at failure,
- ϕ_r = residual angle of internal friction of rock mass,
- E_d = modulus of deformation of rock mass ($\sigma_3 = 0$), and
- E_r = modulus of deformation of the rock material ($\sigma_3 = 0$).

The peak angle of dilatation is approximately equal to $(\phi_p - \phi_r)/2$ for rock joints (Barton and Brandis, 1990) at low σ_3 . This correlation may be assumed for jointed rock masses also.

The proposed strength criterion reduces to Mohr-Coulomb criterion for triaxial conditions.

The significant rock strength enhancement in underground openings is due to σ_2 or insitu stress along tunnels and caverns which pre-stresses rock wedges and prevents their failure both in the roof and the walls. However, σ_3 is released due to stress free excavation boundaries (Figure 13.1d). In the rock slopes σ_2 and σ_3 are nearly equal and negligible. Therefore, there is an insignificant or no enhancement of the strength. As such, block shear tests on a rock mass gives realistic results for rock slopes and dam abutments only; because $\sigma_2 = 0$ in this test. Thus, Eqn. 13.12 may give a general criterion of jointed rock masses for underground openings, rock slopes and foundations.

Another cause of strength enhancement is higher uniaxial compressive strength of rock mass (q_{cmass}) due to higher E_{mass} because of constrained dilatancy and restrained fracture propagation near excavation face only in the underground structures. In rock slopes, E_{mass} is found to be much less due to complete stress release and low confining pressure on account of σ_2 and σ_3 ; and long length of weathered filled-up joints. So, q_{cmass} will also be low near rock slopes.

Through careful back analysis, both the model and its constants should be deduced. Thus, A , E_{mass} and q_{cmass} should be estimated from the feedback of instrumentation data at the beginning of construction stage. With these values, forward analysis should be attempted carefully as mentioned earlier. At present, a non-linear back analysis may be difficult.

The proposed strength criterion is different from Mohr's strength theory which works well for soils and isotropic materials. There is a basic difference in the structure of soil and rock masses. Soils generally have no pre-existing planes of weaknesses and so planar failure can occur on a typical plane with dip direction towards σ_3 . However, rocks have pre-existing planes of weaknesses like joints and bedding planes, etc. As such, failure occurs mostly along these planes of weaknesses. In the triaxial tests on rock masses, planar failure takes place along the weakest joint plane. In polyaxial stress field, a wedge type of failure may be the dominant mode of failure, if $\sigma_2 \gg \sigma_3$. Therefore, Mohr's theory needs to be modified for anisotropic and jointed rock masses.

The new strength criterion is proved by extensive polyaxial tests on anisotropic tuff (Wang and Kemeny, 1995). It is interesting to note that the constant A is the same for biaxial, triaxial and polyaxial tests (Singh et al., 1998).

Further, the effective insitu stresses on ground level in mountainous areas appear to follow Eqn. 13.12 ($q_{\text{cmass}} = 3 \text{ MPa}$, $A = 2.5$) which indicates a state of failure near ground due to the tectonic stresses.

13.4.1 Failure of Laminated Rock Mass

The laminated rock mass is generally found in the roof of underground coal mines and in the bottom of open cast coal mines. The thin rock layers may buckle under high horizontal insitu

stresses first and then they may rupture progressively by violent brittle failure. Therefore, the assumption of shear failure along joints is not valid here. As such, the proposed hypothesis of effective confining stress $[(\sigma_2 + \sigma_3)/ 2]$ may not be applicable in the unreinforced and laminated rock masses.

The suggested hypothesis appears applicable approximately for the rock masses with three or more joint sets.

13.5 Criterion for Squeezing of Rock Masses

Equation 13.12 suggests the following criterion for squeezing ($\sigma_1 = \sigma_\theta$, $\sigma_3 = 0$, $\sigma_2 = P_0$ along tunnel axis in Figure 13.1d),

$$\sigma_\theta > q_{c\text{mass}} + \frac{A \cdot P_0}{2} \quad (13.13)$$

Palmstrom (1995) has observed that $\sigma_\theta/q_{c\text{mass}}$ or σ_θ/RM_i may be much higher than 1 (Table 10.5), i.e., 1.5 to 3 for squeezing. Thus, his experience tend to confirm the proposed criterion (Eqn. 13.13) which shows that squeezing may occur when the constant A is small. There is now need for insitu triaxial test data for further proof.

Experience from eleven tunnels in the Himalaya has shown that squeezing ground conditions are generally encountered where the peak angle of internal friction ϕ_p is less than 30° , J_r / J_a is less than 0.5 and overburden is higher than $350 Q^{1.3}$ m in which Q is Barton's rock mass quality. The predicted support pressures using Eqn. 13.12 are in better agreement with observed support pressure in the roof and wall than those by Mohr's theory (Chaturvedi, 1998).

13.6 Tensile Strength Across Discontinuous Joints

The length of joints is generally less than say 5 m in tunnels in young rock masses except for bedding planes. Discontinuous joints thus have tensile strength. Mehrotra (1996) has conducted 44 shear block tests on both nearly dry and saturated rock masses. He also obtained non-linear strength envelopes for various rock conditions. These strength envelopes were extrapolated carefully in tensile stress region so that it is tangential to the Mohr's circle for uniaxial tensile strength as shown in Figure 13.2. It was noted that the non-linear strength envelopes for both nearly dry and saturated rock masses converged to nearly the same uniaxial tensile strength across discontinuous joints (q_{ij}) within the blocks of rock masses. It is related to Barton's rock mass quality (Figure 13.3) as follows:

$$q_{ij} = 0.029 \gamma Q^{0.31} \quad \text{MPa} \quad (13.14)$$

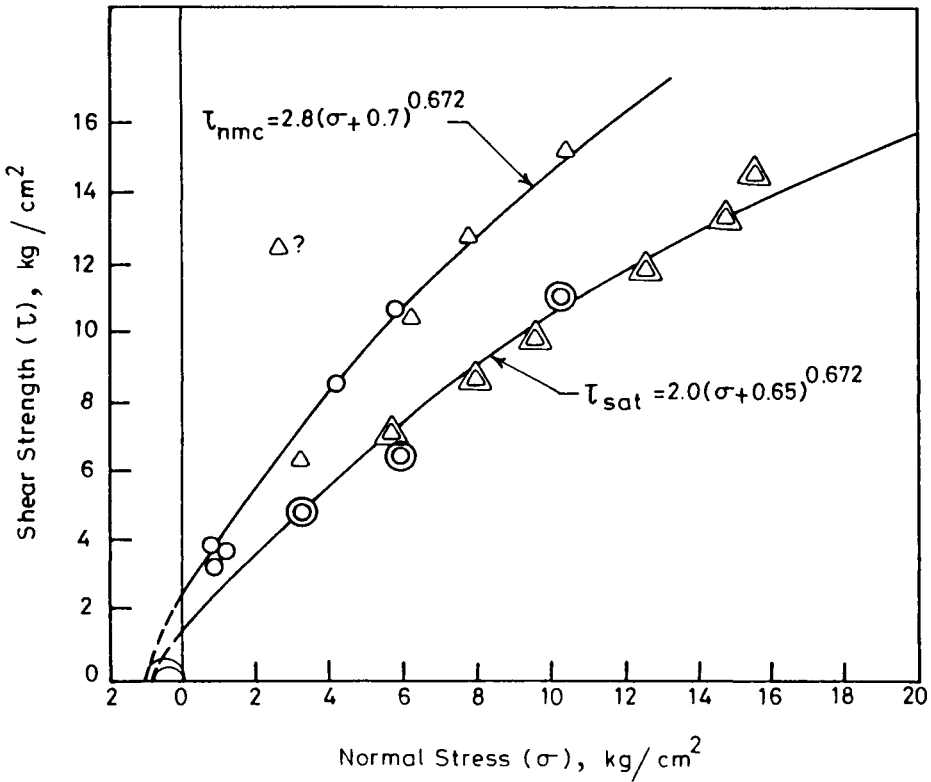

Figure 13.2: Estimation of tensile strength of rock mass from Mohr's envelope (Mehrotra, 1993)

The tensile strength across discontinuous joints is not zero as generally assumed, but it is found to be of significant values specially in hard rocks.

The tensile stress in tunnel roof of span B will be of the order of γB in the vertical direction. Equating this with q_{ij} , the span of self-supporting tunnels obtained from Eq. 13.14 would be $2.9 Q^{0.31}$ m. Barton et al. (1974) found the self-supporting span to be $2 Q^{0.4}$ m. This comparison is very encouraging. Thus, it is understood that the wedge analysis considering q_{ij} and insitu stress along tunnel axis may give more accurate value of the self-supporting tunnel span.

13.7 Dynamic Strength of Rock Mass

It appears logical to assume that dynamic strain at failure should be of the same order as the static strain at failure for a given confining stress. Dynamic strain at failure should be

Strength enhancement of rock mass in tunnels

proportional to modulus of elasticity of rock mass (E_e) and static strain at failure should be proportional to E_{mass} . Therefore, a following correlation for dynamic strength enhancement is proposed.

$$q_{c\text{dyn}}/q_{c\text{mass}} = (E_e/E_{\text{mass}})^{0.7} \tag{13.15}$$

where,

$q_{c\text{dyn}}$ = dynamic strength of rock mass.

In seismic analysis, dynamic strength enhancement may be quite high, particularly for a weathered rock mass, as the instantaneous modulus of elasticity will be much higher than the long-term rock mass modulus (E_{mass}).

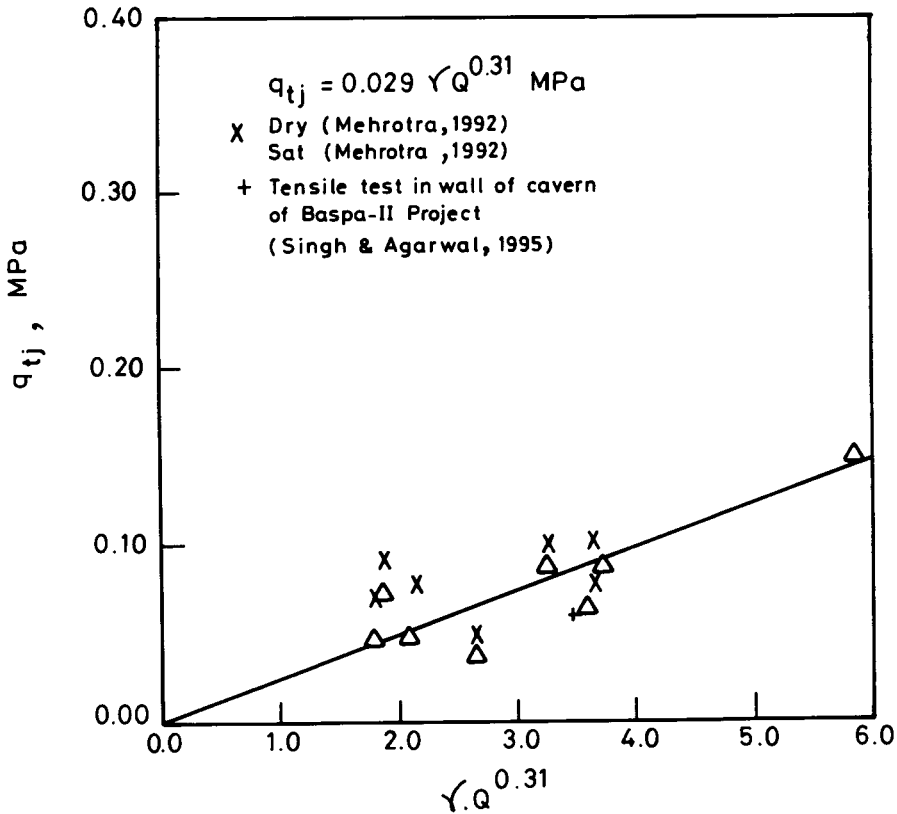

Figure 13.3: Plot between q_{tj} and $\gamma \cdot Q^{0.31}$

Extensive research is urgently needed to obtain more realistic correlations for dynamic strength enhancement.

13.8 Residual Strength Parameters

Mohr's theory will be applicable to residual failure as a rock mass would be reduced to non-dilatant soil-like condition. The mobilized residual cohesion c_r is approximately equal to 0.1 MPa and is not negligible unless tunnel closure is more than 5.5% of its diameter. The mobilized residual angle of internal friction ϕ_r is about 10° less than the peak angle of internal friction ϕ_p but more than 14° .

References

- Barton, N. and Brandis, S. (1990). Review of Predictive Capabilities of JRC-JCS Model in Engineering Practice, Reprinted from: Barton, N. R. & O. Stephansson (eds), *Rock Joints Proc. of a regional conference of the International Society for Rock Mechanics*, Leon, 4-6.6.1990. 1990. 820 pp., Hfl. 280/-, US\$140.00/£93. A. A. Balkema, P.O. Box 1675, Rotterdam, Netherlands.
- Balkema, Rotterdam, pp. 603 - 610.
- Barton, N., Lien, R. and Lunde, J. (1974). Engineering Classification of Rock Masses for the Design of Tunnel Support, *Rock Mechanics*, Springer-Verlag, **Vol. 6**, pp. 189-236.
- Bazant, Z. P., Lin, F.B. and Lippmann, H. (1993). Fracture Energy Release and Size Effect in Borehole Breakout, *Int. J. Num. & Analytical Methods in Geomech.*, John Wiley, **Vol. 17**, pp. 1-14.
- Bieniawski, Z. T. (1976). Rock Mass Classification in Rock Engineering, *In Exploration for Rock Engineering. Proc. of the Symp.* (ed. Z. T. Bieniawski), **1**, Cape Town, pp. 97-106.
- Chaturvedi, A. (1998). Strength of Anisotropic Rock Masses, M. E. Thesis, Department of Civil Engineering, University of Roorkee, India, p.82.
- Goel, R. K. (1994). Correlations for Predicting Support Pressures and Closures in Tunnels *Ph.D. Thesis, Visvesvaraya Regional College of Engineering*, Nagpur, India, p.347.
- Goel, R. K., Jethwa, J. L. and Paithankar, A. G. (1996). Correlation Between Barton's Q and Bieniawski's RMR - A New Approach, *Technical Note Int. Jr. of Rock Mech. and Min. Sci. & Geomech. Abstr.*, Pergamon, **Vol. 33, No. 2**, pp. 179-181.
- Grimstad, E. and Bhasin, R. (1996). Stress Strength Relationships and Stability in Hard Rock, *Proc. Conf. on Recent Advances in Tunnelling Technology*, New Delhi, India, **Vol. 1**, pp. 3 - 8.
- Hoek, E. and Brown, E. T. (1980). *Underground Excavations in Rock*, Institution of Mining and Metallurgy, London, England, Revised Edition.
- Hoek, E. (1994). Strength of Rock and Rock Masses, *ISRM News Journal*, **No. 2**, pp.4-16.
- Hoek, E. (1998). Personal Discussions with Prof. Bhawani Singh on April 4, 1998 at Tehri Hydro Development Corporation Ltd., Rishikesh, India.
- Lecture Notes of *Workshop on Behaviour of Concrete Under Multiaxial States of Stress*, Organised by Central Board of Irrigation & Power and Central Soils & Material Research Station, New Delhi, 1987, pp. 1.1 to 5.75.

- Mehrotra, V. K. (1993). Estimation of Engineering Parameters of Rock Mass, *Ph. D. Thesis. University of Roorkee*, Roorkee, India, p.267.
- Mehrotra, V. K. (1996). Failure Envelopes for Jointed Rocks in Lesser Himalaya, *Jr. Rock Mech. and Tunnelling Technology*, Indian Society of Rock Mechanics and Tunnelling Technology, **Vol.2, No.1**, pp.59-74.
- Murrell, S. A. K. (1963). A Criterion for Brittle Fracture of Rocks and Concrete under Triaxial Stress and the Effect of Pore Pressure on the Criteria, *Vth Sym. on Rock Mech.. University of Minnesota, ed. Fairhurst, C., Oxford, Pergamon*, pp. 563-577.
- Pande, G. N. (1997). SQCC Lecture on Application of the Homogenisation Techniques in Soil Mechanics and Structure, Sept. 26, *University of Roorkee*, Roorkee, India.
- Ramamurthy, T. (1993). Strength and Modulus Responses of Anisotropic Rocks. *Comprehensive Rock Engineering*, Pergamon, **Vol. 1, Chapter 13**, pp.313-329.
- Roy, Nagendra. (1993). Engineering Behaviour of Rock Masses Through Study of Jointed Models, *Ph. D. Thesis, Civil Engineering Department, I.I.T., New Delhi*, p.365.
- Sakurai, S. (1993). Back Analysis in Rock Engineering, *ISRM News Journal*, **Vol.2, No.2**, pp.4 -16.
- Sheorey, P. R. (1997). *Empirical Rock Failure Criterion*, Published Jointly by Oxford & IBH Publishing Co. and A.A. Balkema, p. 176.
- Singh, Bhawani, Viladkar, M. N., Samadhiya, N. K. and Mehrotra, V. K. (1997). Rock Mass Strength Parameters Mobilized in Tunnels, *Jr. Tunnelling and Underground Space Technology*, Pergamon, **Vol.12**, No.1, pp. 47-54.
- Singh, Bhawani, Goel, R. K., Mehrotra, V. K., Garg, S. K. and Allu, M. R. (1998). Effect of Intermediate Principal Stress on Strength of Anisotropic Rock Mass, *Jr. Tunnelling & Underground Space Technology*, Pergamon, **Vol. 13**, No. 1, pp. 71-79.
- Verman, Manoj. (1993). Rock Mass - Tunnel Support Interaction Analysis. *Ph. D. Thesis. University of Roorkee*, Roorkee, India, p.267.
- Wang, R. and Kemeny J. M. (1995). A New Empirical Failure Criterion Under Polyaxial Compressive Stresses, Reprinted from: Daemen, Jaak J.K. & Richard A. Schultz (eds), *Rock Mechanics: Proc. 35th U. S. Symposium-Lake Tahoe, 4-7 June 1995*. 1995, 950 pp., Hfl. 220/-, US\$110.00/£73. A. A. Balkema, P.O. Box 1675, Rotterdam, Netherlands.

CHAPTER - 14

STRENGTH OF DISCONTINUITIES

"Failure is success if we learn from it"

Malcom S. Forbes

14.1 Introduction

Rock mass is a heterogeneous, anisotropic and discontinuous mass. When civil engineering structures like dams are founded on rock, they transmit normal and shear stresses on rock mass discontinuities. Failure may be initiated by sliding along a joint plane near or along the foundation or along the abutments of dam. For a realistic assessment of the stability of structure, estimation of the shear resistance of a rock mass along any desired plane of potential shear or along the weakest discontinuity becomes essential. The strength of discontinuities depends upon the alteration of joints or the discontinuities, the roughness, the thickness of infillings or the gouge material, the moisture content, etc.

The mechanical difference between contacting and non-contacting joint walls will usually result in widely different shear strengths and deformation characteristics. In the case of unfilled joints, the roughness and compressive strength of the joint walls are important, while in the case of filled joints the physical and mineralogical properties of the gouge material separating the joint walls are of primary concern.

To quantify the effect of these on the strength of discontinuities, various researchers have proposed different parameters and correlations for obtaining strength parameters. Barton et al. (1974), probably for the first time, have considered joint roughness (J_r) and joint alteration (J_a) in their Q-system to take care of the strength of clay coated discontinuities in the rock mass classification. Later, Barton and Choubey (1977) defined two parameters - joint wall roughness coefficient JRC and joint wall compressive strength JCS and proposed an empirical correlation for friction of rock joints without fillings which can be used both for extrapolating and predicting shear strength data accurately.

14.2 Joint Wall Roughness Coefficient (JRC)

The wall roughness of a joint or discontinuity is a potentially very important component of its shear strength, especially in the case of undisplaced and interlocked features (e.g. unfilled joints). The importance of wall roughness declines as aperture filling thickness, or the degree of any previous displacement increases.

Strength of discontinuities

JRC₀ (JRC at laboratory scale) can be obtained by visual matching of actual roughness profiles with the set of standard profiles proposed by Barton and Choubey (1977). As such, the joint roughness coefficients are suggested for ten types of roughness profiles of joints (Figure 14.1). The core sample will be intersected by joints at angles varying from 0 to 90° to the axis. Joint samples will therefore vary in some cases from a metre or more in length (depending upon the core length) to 100mm (core diameter). Most samples are expected to be in the range of 100 to 300 mm in length.

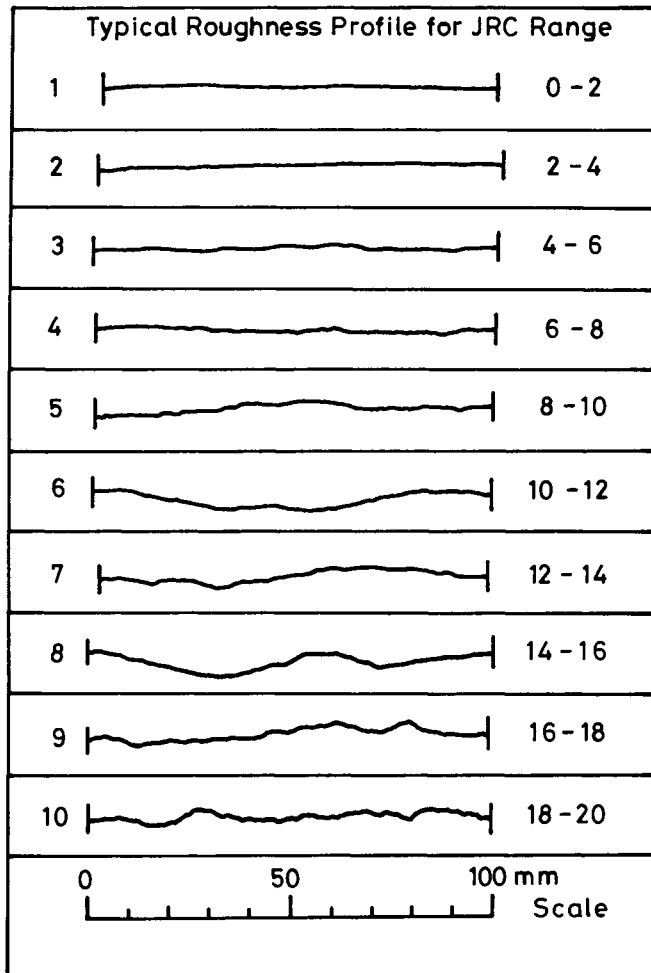

Figure 14.1: Standard profiles for visual estimation of JRC (Barton and Choubey, 1977)

The recommended approximate sampling frequency for the above profile matching procedure is 100 samples per joint set per 1000m of core. The two most adverse prominent sets should be selected which must include the adverse joint set selected for J_r and J_a characterization.

Roughness amplitude per length, i.e., a/L measurements will be made in the field for estimating JRC_n (JRC at large scale). The maximum amplitude of roughness (in mm) should be usually estimated or measured on profiles of at least two lengths along the joint plane, for example 100mm length and 1m length.

It has been observed that the JRC_n can also be obtained from JRC_o using the following equation

$$JRC_n = JRC_o (L_n / L_o)^{-0.02 JRC_o} \quad (14.1)$$

where L_o is the laboratory scale length, i.e., 100mm and L_n represents the larger scale length.

Using chart of Barton (1982) presented in Figure 14.2 is easier for evaluating JRC_n according to the amplitude of asperities and the length of joint profile studied in the field.

14.2.1 Relationship Between J_r and JRC Roughness Descriptions

The description of roughness given in the Q-system by the parameter J_r (see Table 8.3), and the JRC are related. Figure 14.3 has been prepared by Barton (1993) for the benefit of users of these rock mass descriptions. The ISRM (1978) suggested methods for visual description of joint roughness profiles have been combined with profiles given by Barton et al. (1980) and with Equation 14.1, to produce some examples of the quantitative description of joint roughness that these parameters provide.

The roughness profiles shown in Figure 14.3 are assumed to be atleast 1m in length. The column of J_r values would be used in Q-system, while the JRC values for 20cm and 100cm block size could be used to generate appropriate shear stress displacement and dilation - displacement curves.

14.3 Joint Wall Compressive Strength (JCS)

The joint wall compressive strength (JCS) of a joint or discontinuity is a potentially very important component of its shear strength, especially in case of undisplaced and interlocked discontinuities, e.g., unfilled joints (Barton and Choubey, 1977). As in the case of JRC, the wall strength JCS decreases as aperture or filling thickness or the degree of any previous displacement increases. JCS, therefore, need not be evaluated for thickly (>10mm) filled joints.

In the field, JCS is measured by performing Schmidt Hammer (L-type) tests on the two most prominent joint surfaces where it is smooth and averaging the highest 10 rebound values.

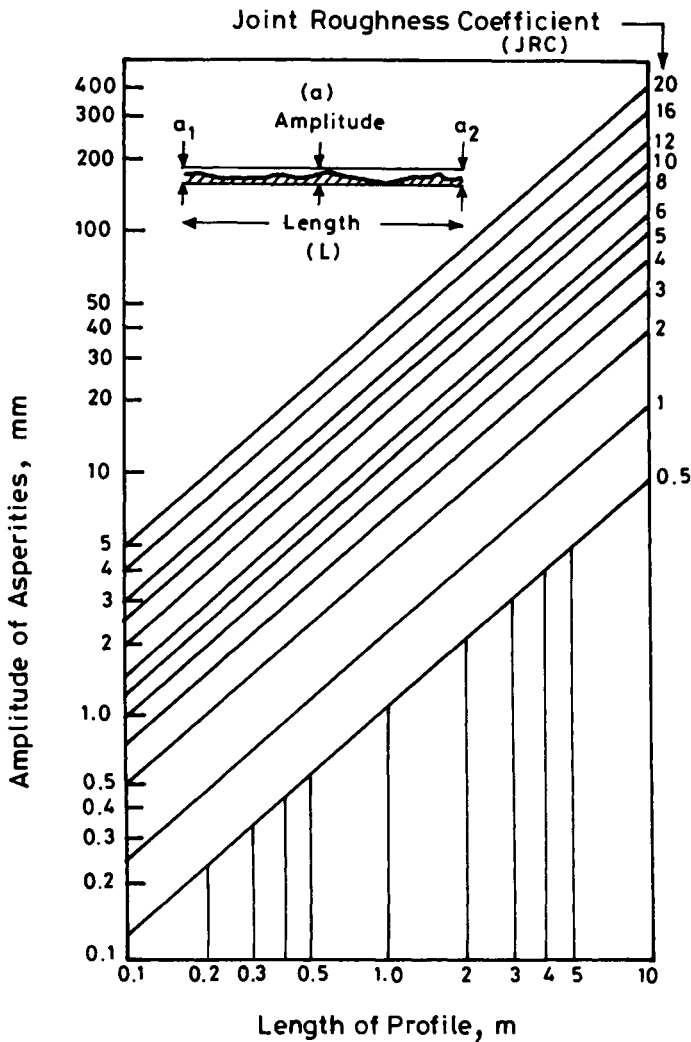

Figure 14.2: Assessment of JRC from amplitude of asperities and length of joint profile (Barton, 1982)

JRC_0 , the small scale value of wall strength relative to a nominal joint length (L_0) of 100mm, may be obtained from the Schmidt hammer rebound value (r) as follows or by using Figure 14.4.







| Relation Between J_r and JRC_n Subscripts Refer to Block Size (cm) | | J_r | JRC_{20} | JRC_{100} |
|---|---|-------|------------|-------------|
| I | Rough  | 4 | 20 | 11 |
| II | Smooth  | 3 | 14 | 9 |
| III | Slickensided  | 2 | 11 | 8 |
| Stepped | | | | |
| IV | Rough  | 3 | 14 | 9 |
| V | Smooth  | 2 | 11 | 8 |
| VI | Slickensided  | 1.5 | 7 | 6 |
| Undulating | | | | |
| VII | Rough  | 1.5 | 2.5 | 2.3 |
| VIII | Smooth  | 1.0 | 1.5 | 0.9 |
| IX | Slickensided  | 0.5 | 0.5 | 0.6 |
| Planar | | | | |

Figure 14.3: Suggested methods for the quantitative description of different classes of joints using J_r and JRC . Subscript refer to block size in cms.

$$JCS_o = 10^{(0.0008 r \gamma + 1.01)} \text{ MPa} \quad (14.2)$$

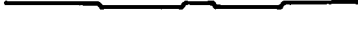
where,

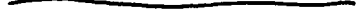
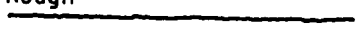
r = rebound number, and

γ = dry density of rocks.

In case Schmidt hammer is not used vertically downward, the rebound values need correction as given in Table 14.1.

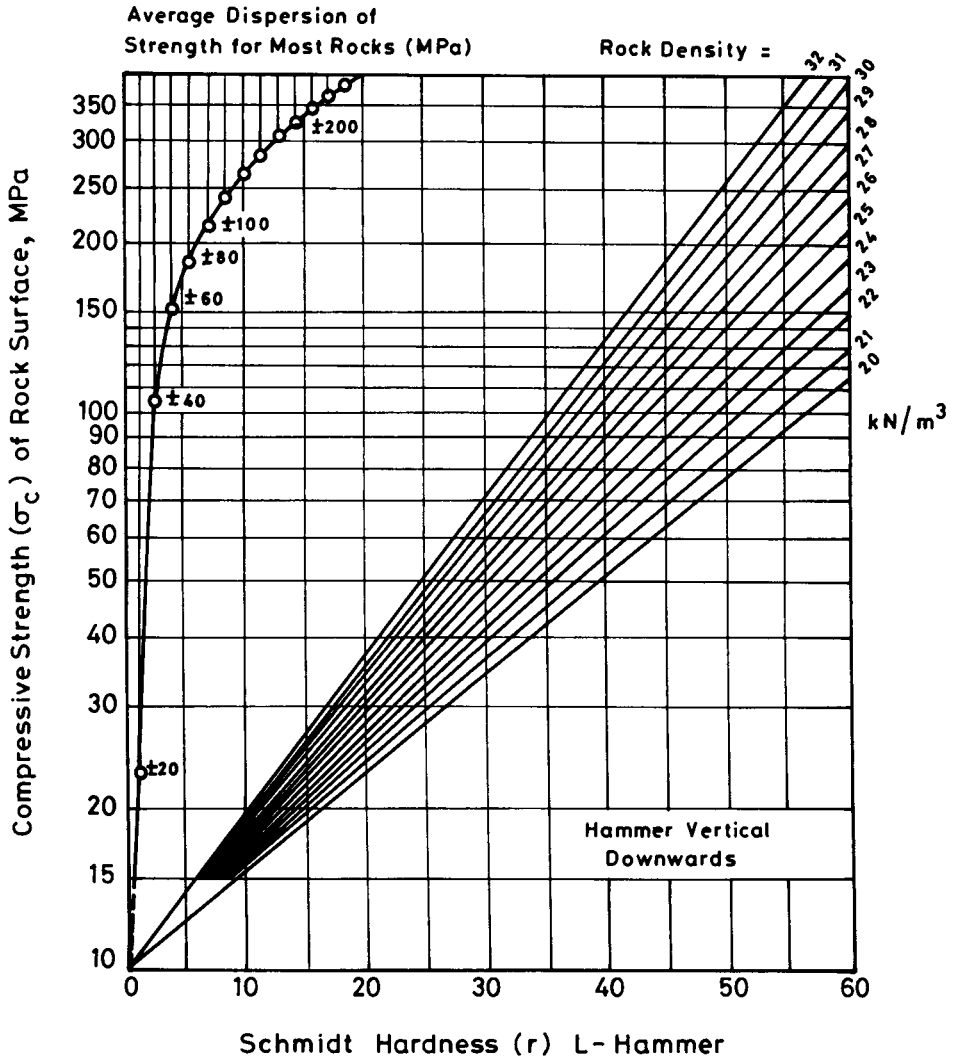

Figure 14.4: Correlation chart for Schmidt hammer, rock density, compressive strength and rebound number on smooth surfaces (Miller, 1965)

The joint wall compressive strength may be equal to uniaxial compressive strength of rock material for unweathered joints, otherwise it should be estimated indirectly from Schmidt hammer index test. It is experienced that Schmidt hammer is found to give entirely wrong results on rough joints. Therefore, it is advisable not to use Schmidt hammer rebound for JCS in case of rough joints. Lump tests on saturated small lumps of asperities will give better UCS or JCS₀.

TABLE 14.1
CORRECTIONS FOR THE ORIENTATION OF SCHMIDT HAMMER
(BARTON & CHOUBEY, 1977)

| Rebound | Downward | | Upward | | Horizontal |
|---------|----------------------|----------------------|----------------------|----------------------|--------------------|
| | $\alpha = -90^\circ$ | $\alpha = -45^\circ$ | $\alpha = +90^\circ$ | $\alpha = +45^\circ$ | |
| r | $\alpha = -90^\circ$ | $\alpha = -45^\circ$ | $\alpha = +90^\circ$ | $\alpha = +45^\circ$ | $\alpha = 0^\circ$ |
| 10 | 0 | -0.8 | - | - | -3.2 |
| 20 | 0 | -0.9 | -8.8 | -6.9 | -3.4 |
| 30 | 0 | -0.8 | -7.8 | -6.2 | -3.1 |
| 40 | 0 | -0.7 | -6.6 | -5.3 | -2.7 |
| 50 | 0 | -0.6 | -5.3 | -4.3 | -2.2 |
| 60 | 0 | -0.4 | -4.0 | -3.3 | -1.7 |

For larger blocks or joint lengths (L_n), the value of JCS reduces to JCS_n , where the two are related by the following empirical equation:

$$JCS_n = JCS_0 (L_n / L_0)^{-0.03 JRC_0} \quad , \text{ MPa} \quad (14.3)$$

where JCS_n is the joint wall compressive strength at a larger scale.

14.4 Joint Matching Coefficient (JMC)

Zhao (1997) suggested a new parameter, joint matching coefficient (JMC), in addition to JRC and JCS for obtaining shear strength of joints. JMC can be obtained by observing the approximate percentage area in contact between the upper and the lower walls of a joint. Thus, JMC has a value between 0 and 1.0. A JMC value of 1.0 represents a perfectly matched joint, i.e., with 100 per cent surface contact. On the other hand, a JMC value close to 0 (zero) indicates a totally mismatched joint with no or minimum surface contact.

14.5 Angle of Internal Friction

Residual friction angle ϕ_r of a joint is a very important component of its total shear strength, whether the joint is rock-to-rock interlocked or clay filled. The importance of ϕ_r increases as the clay coating or filling thickness increases, of course upto a certain limit (Chapter 23).

An experienced field observer may make a preliminary estimate of ϕ_r . The value for quartz rich rocks and many igneous rocks have ϕ_r between 28° and 32° . Whereas, mica-rich rock masses and rocks having considerable effect of weathering have somewhat lower values of ϕ_r than mentioned above.

Strength of discontinuities

In the Barton - Bandis joint model, it is proposed to add angle of primary roughness for obtaining the field value of peak friction angle for a natural joint (ϕ_j) without fillings,

$$\phi_j = \phi_r + i + JRC \log_{10}(JCS/\sigma) < 70^\circ ; \text{ for } \sigma / JCS < 0.3 \quad (14.4)$$

where JRC accounts for secondary roughness in laboratory tests, 'i' represents angle of primary roughness (undulations) of natural joint surface and is generally $\leq 6^\circ$, and σ is the effective normal stress across joint.

The expression $[JRC \log_{10}(JCS/\sigma)]$ in the above equation represents approximately the dilation angle of a joint. It may be noted that at high pressures ($\sigma = JCS$), no dilatation will take place as all asperities will get sheared.

It may be noted here that the value of ϕ_r is important as roughness (JRC) and wall strength (JCS) reduce through weathering.

Residual frictional angle ϕ_r can also be estimated by the equation:

$$\phi_r = (\phi_b - 20^\circ) + 20 (r/R) \quad (14.5)$$

where ϕ_b is the basic frictional angle obtained by sliding or tilt tests on dry, planar (but not polished) or cored surface of the rock (Barton and Choubey, 1977), R is the Schmidt rebound on fresh, dry unweathered smooth surfaces of the rock and r is the rebound on the smooth natural, perhaps weathered and water-saturated joints.

According to Jaeger and Cook (1969), enhancement in the dynamic angle of sliding friction ϕ_r of smooth rock joints may be about 2° only.

For clay-coated joints, the sliding angle of friction (ϕ_j) is found to be,

$$\phi_j = \tan^{-1}(J_r/J_a) \geq 14^\circ \quad (14.6)$$

14.6 Shear Strength of Joints

Barton and Choubey (1977) have proposed the following non-linear correlation for shear strength of natural joints which is found surprisingly accurate.

$$\tau = \sigma \cdot \tan [\phi_r + JRC_n \log_{10}(JCS_n/\sigma)] \quad (14.7)$$

where τ is the shear strength of joints, JRC_n may be obtained easily from Figure 14.2, JCS_n from Eqn. 14.3 and rest of the parameters are defined above.

The effect of mismatching of joint surface on its shear strength has been proposed by Zhao (1997) in his JRC-JCS shear strength model (Eqn. 14.8),

$$\tau = \sigma \cdot \tan [\phi_r + JMC \cdot JRC_n \log_{10} (JCS_n / \sigma)] \quad (14.8)$$

The minimum value of JMC in the above equation should be taken as 0.3.

The shear stiffness of joint is defined as the ratio between shear strength τ in Eqn. 14.7 above and the peak slip. The latter may be taken equal to $(S/500) \cdot (JRC/S)^{0.33}$ where 'S' is equal to the length of a joint or simply the spacing of joints. The normal stiffness of a joint may be 10 to 30 times its shear stiffness. This is the reason why the shear modulus of jointed rock masses is considered to be very low as compared to that for an isotropic elastic medium (Singh, 1973).

For joints filled with gouge, the following correlation of shear strength is used for low normal stresses (Barton and Brandis, 1990);

$$\tau = \sigma \cdot (J_r / J_a) \quad (14.9)$$

In the case of highly jointed rock masses, failure takes place along the shear band (kink band) and not along the critical discontinuity. Thus, value of JCS in a rock mass is suggested to be its uniaxial compressive strength $q_{c\text{mass}}$. More attention should be given to strength of discontinuity in the jointed rock masses.

References

- Barton, N. (1982). Shear Strength Investigations for Surface Mining, Ch. 7, *3rd Int. Conf. on Surface Mining*, Vancouver, **SME 1982**, pp. 171-196.
- Barton, N. (1993). Predicting the Behaviour of Underground Openings in Rock, Proc. *Workshop on Norwegian Method of Tunnelling, CSMRS-NGI Institutional Co-operation Programme*, September, New Delhi, India, pp. 85-105.
- Barton, N. and Brandis, S. (1990). Review of Predictive Capabilities of JRC-JCS Model in Engineering Practice, Reprinted from: Barton, N. R. & O. Stephansson (eds), *Rock Joints* Proc. of a regional conference of the International Society for Rock Mechanics, Leon, 4-6.6.1990. 820 pp., Hfl. 280/-, USS140.00/£93. A. A. Balkema, P.O. Box 1675, Rotterdam, Netherlands.
- Barton, N. and Choubey, V. D. (1977). The Shear Strength of Rock Joints in Theory and Practice, *Rock Mech.*, Springer-Verlag, **No. 1/2**, pp. 1-54. Also NGI-Publ. 119, 1978.
- Barton, N., Lien, R. and Lunde, J. (1974). Engineering Classification of Rock Masses for the Design of Tunnel Support, *Rock Mechanics*, Springer-Verlag, **Vol. 6, No. 4**, pp. 189-236.
- Barton, N., Loset, F., Lien, R. and Lunde, J. (1980). Application of Q-system in Design Decisions Concerning Dimensions and Appropriate Support for Underground

Strength of discontinuities

- Installations, Int. Conf. on Sub-surface Space, *Rock Store*, Stockholm, Sub-Surface Space, **Vol. 2**, pp.553-561.
- ISRM (1978), Suggested Methods for the Quantitative Description of Discontinuities in Rock Masses, (Co-ordinator Barton, N.), *Int. Jr. Rock Mech. and Min. Sci. & Geomech. Abstr.*, Pergamon, **Vol. 15**, pp. 319-368.
- Jaeger, J. C. and Cook, N. G. W. (1969). *Fundamentals of Rock mechanics*, Mathew and Co. Ltd., Art. 3.4
- Miller, R. P. (1965). Engineering Classification and Index Properties for Intact Rock. *Ph. D. Thesis, University of Illinois*, USA, pp. 1-282.
- Singh, Bhawani. (1973). Continuum Characterization of Jointed Rock Mass: Part II - Significance of Low Shear Modulus, *Int. Jr. of Rock Mech. and Min. Sci. & Geomech. Abstr.*, Pergamon, **Vol. 10**, pp. 337-349.
- Tse, R. and Cruden, D.M. (1979). Estimating Joint Roughness Coefficients, *Int. Jr. Rock Mech. and Min. Sci. & Geomech. Abstr.*, Pergamon, **Vol. 16**, pp. 303-307.
- Zhao, J. (1997). Joint Surface Matching and Shear Strength, Part B : JRC-JMC Shear Strength Criterion, *Int. Jr. Rock Mech. and Min. Sci. & Geomech. Abstr.*, Pergamon, **Vol. 34, No. 2**, pp. 179-185.

SHEAR STRENGTH OF ROCK MASSES IN SLOPES

"Failure does not take place homogeneously in a material, but failure occurs by strain localization along shear bands, tension cracks in soils, rocks, concrete, masonry and necking in ductile material"

Prof. G. N. Pandey, 1997

15.1 Mohr-Coulomb Strength Parameters

Stability analysis of a rock slope requires assessment of shear strength parameters, i.e., cohesion c and angle of internal friction ϕ of the rock mass. Estimates of these parameters are usually not based on extensive field tests. Mehrotra (1993) has carried out extensive block shear tests to study the shear strength parameters of the rock masses.

The following inferences may be drawn from the study of Mehrotra (1993):

- (i) RMR system may be used to estimate the shear strength parameters c and ϕ of the weathered and saturated rock masses. It was observed that the cohesion c and the angle of internal friction ϕ increase with the increase in RMR as in Table 6.10 and Figure 15.1.
- (ii) The effect of saturation on shear strength parameters has been found to be significant. For poor saturated (wet) rock masses, a maximum reduction of 70 per cent has been observed in cohesion c while the reduction in angle of internal friction ϕ is of the order of 35 per cent when compared to those for dry rock masses.
- (iii) Figure 15.1 shows that there is a non-linear variation of the angle of internal friction with RMR for dry rock masses. The study also shows that ϕ values of Bieniawski (1989) are somewhat conservative.

15.2 Non-Linear Failure Envelopes for Rock Masses

Dilatancy in a rock mass is unconstrained near slopes as normal stress on joints is fixed by weight of the wedge. So, the failure of a rock mass occurs partially along joints and partially in non-jointed portions, i.e., solid rocks. But in massive rocks, it may occur entirely in solid rocks. Therefore, the failure of a rock mass lies within the area bounded by the failure envelope for a solid rock and that of a joint. The mode of failure thus depends on the quality and the type of the rock mass under investigation.

Shear strength of rock masses in slopes

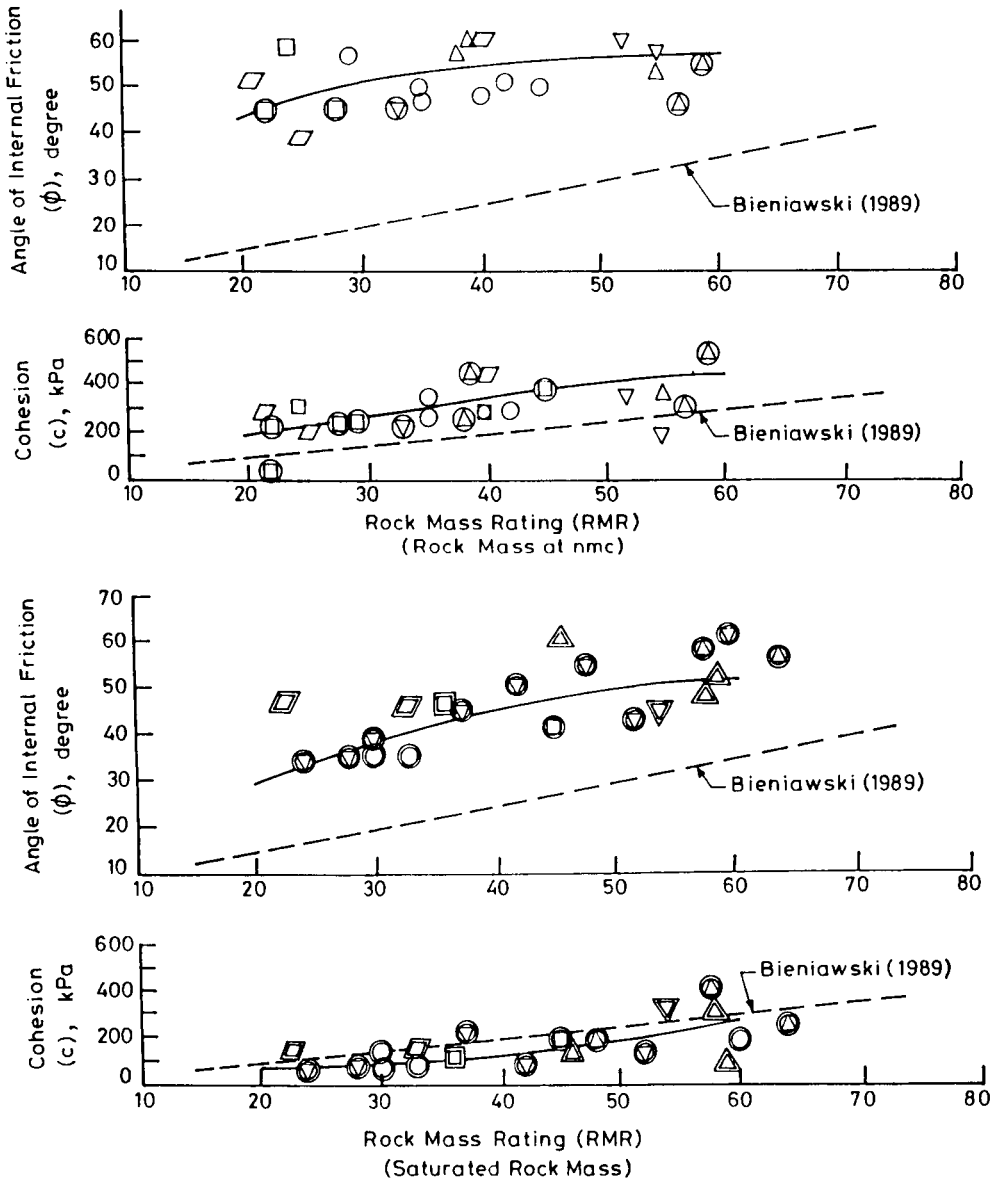

Figure 15.1: Relationship between rock mass rating RMR and shear strength parameters, cohesion c and angle of internal friction ϕ (Mehrotra, 1993)[nmc: natural moisture content]

In case of poor rock masses, the magnitude of normal stress σ influences the shear strength significantly. A straight line envelope is therefore not a proper fit for such data and is likely to lead to over-estimation of angle of internal friction ϕ at higher normal stresses.

The failure envelopes for the rock masses generally show a non-linear trend. A straight line criterion may be valid only when loads are small ($\sigma \ll q_c$) which is generally not the case in civil engineering (hydroelectric) projects where the intensity of stresses is comparatively high. The failure envelopes based on generalized empirical power law may be expressed as follows (Hoek and Brown, 1980):

$$\tau = (\sigma + T)^B \quad (15.1)$$

where,

τ = tensile strength of rock mass,
A, B & T = rock mass constants.

For known values of power factor B, constants A and T have been worked out from a series of block shear test data. Consequently, empirical equations for the rock masses, both at natural moisture content and at saturation, have been calculated for defining failure envelopes. The values of the power factor B have been assumed to be the same as in the equations proposed by Hoek and Brown (1980) for heavily jointed rock masses.

Mehrotra (1993) has plotted the Mohr envelopes for four different categories of rock masses namely - (i) limestones, (ii) slates, xenoliths, phyllites, (iii) metabasics, traps and (iv) sandstones and quartzites. One such typical plot is shown in Figure 15.2 and another in Figure 13.2. The constants A and T have been estimated using the results obtained from the insitu block shear tests carried out on the Lesser Himalayan rocks. Recommended non-linear strength envelopes (Table 15.1) may be used only for preliminary designs of dam abutments and rock slopes. There is scope of refinement if the present data are supplemented with insitu triaxial test data. For RMR > 60, shear strength will be governed by strength of rock material because failure plane will partly pass through solid rock.

Results of the study of Mehrotra (1993) for poor and fair rock masses are presented below.

Poor Rock Masses (RMR = 23 to 37)

- (i) It is possible to estimate the approximate shear strengths from the data obtained from insitu block shear tests.
- (ii) Shear strength of the rock mass is stress-dependent. The cohesion of the rock mass varies from 0.13 MPa to 0.16 MPa for saturated and about 0.22 MPa for naturally moist rock masses.
- (iii) Beyond the normal stress σ value of 2 MPa, there is no significant change in the values of $\tan \phi$. It is observed that the angle of internal friction ϕ of rock mass is asymptotic at 20°.

Shear strength of rock masses in slopes

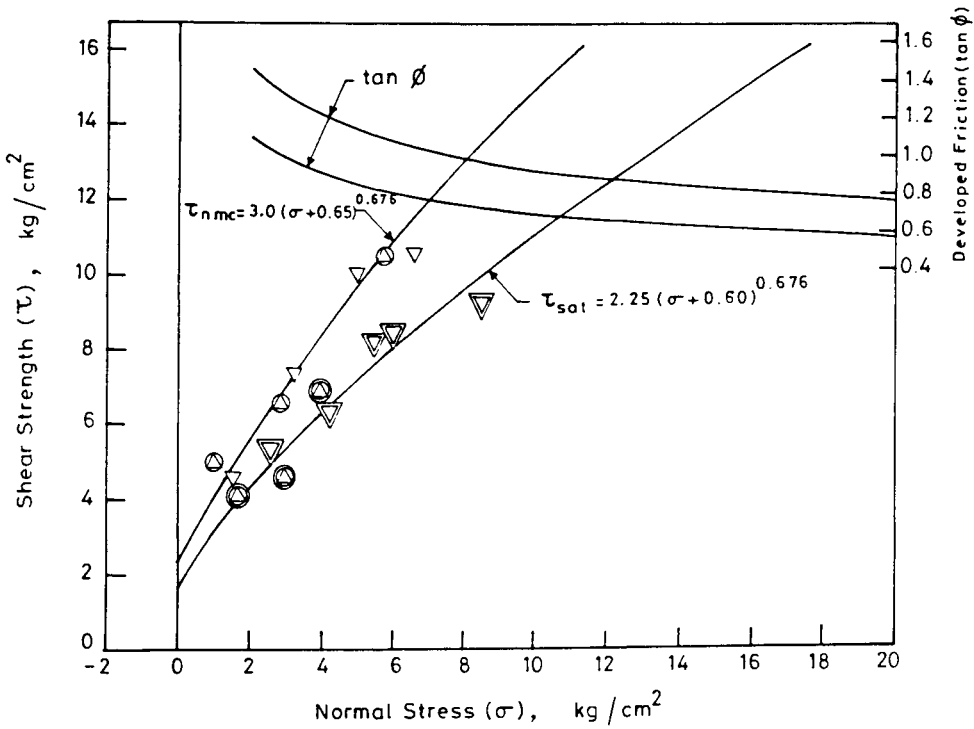

Figure 15.2: Failure envelopes for jointed trap and metabasic rocks at natural moisture content (nmc) and under saturated conditions

- (iv) The effect of saturation on the shear strength is found to be significant. When saturated, the reduction in the shear strength is about 30 per cent at the normal stress (σ) of 2 MPa.

Bieniawski (1989) has suggested that ϕ may decrease to zero if RMR reduces to zero. This is not borne out by field experience. Even sand has much higher angle of internal friction. Limited direct shear tests by University of Roorkee, India suggest that ϕ is above 15° for very poor rock masses (RMR = 0 - 20).

Fair Rock Masses (RMR = 41 to 58)

- (i) It is possible to estimate approximate shear strength from insitu block shear test data.
- (ii) Shear strength of a rock mass is stress dependent. At natural moisture content the cohesion intercept of the rock mass is about 0.3 MPa. At saturation, the cohesion intercept varies from 0.23 to 0.24 MPa.

- (iii) Beyond a normal stress (σ) value of 2 MPa, there is no significant change in the values of $\tan \phi$. It is observed that the angle of internal friction of a rock mass is asymptotic at 27° .
- (iv) The effect of saturation on the shear strength is found to be significant. When saturated, the reduction in the shear strength is about 25 per cent at the normal stress (σ) of 2 MPa.

15.3 Strength of Rock Masses in Slopes

As discussed in Chapter 13, it has been highlighted by Singh et al. (1997) that

- (i) E_{mass} and q_{cmass} are significantly higher in deep tunnels than those near the ground surface and rock slopes for the same value of rock mass quality except near faults and thrusts.
- (ii) The Hoek and Brown (1992) criterion is applicable to rock slopes and open-cast mines with weathered and saturated rock masses. Block shear tests suggest q_{cmass} to be $0.38 \gamma Q^{1/3}$ MPa ($Q < 10$), as joint orientation becomes a very important factor due to unconstrained dilatancy and negligible intermediate principal stress unlike in tunnels. So, block shear tests are recommended only for slopes and not for supported deep underground openings.
- (iii) The angle of internal friction of rock masses with mineral coated joint walls may be assumed as $\tan^{-1}(J_r/J_a)$ approximately.
- (iv) In case of rock slopes both σ_2 and σ_3 are negligible. Therefore, there is insignificant or no strength enhancement in case of slopes. As such, block shear tests on rock masses give realistic results for rock slopes and dam abutments only; because σ_2 is zero in these tests. Thus, Eqn. 13.12 may give a general failure criterion of jointed rock masses for underground openings, rock slopes and foundations (Singh et al., 1998).
- (v) In rock slopes, E_{mass} is found to be much lower due to complete relaxation of insitu stress, low confining pressures σ_2 and σ_3 , excessive weathering and longer length of joints. For the same Q , therefore, q_{cmass} will also be low near rock slopes.

15.4 Back Analysis of Distressed Slopes

The most reliable method of estimating strength parameters along discontinuities or of rock masses is by appropriate back analysis of distressed rock slopes. Software package BASP, BASC and BAST have been developed at University of Roorkee to back calculate strength parameters for planar, circular and debris slides respectively.

Shear strength of rock masses in slopes

The experience of careful back analysis of rock slopes also supports Bieniawski's values of strength parameters.

References

- Hoek, E. and Brown E. T. (1980). *Underground Excavations in Rock*, Institution of Mining & Metallurgy, London, Revised Edition.
- Hoek, E. (1994). Strength of Rock and Rock Masses, *ISRM News Journal*, **Vol. 2**, pp. 4-16.
- Hoek, E., Wood, D. and Shah, S. (1992). A Modified Hoek-Brown Failure Criterion for Jointed Rock Masses, ISRM Symposium, *Eurock '92 on Rock Characterization*, ed. J. A. Hudson, Thomas Telford, London.
- Mehrotra, V. K. (1993). Estimation of Engineering Parameters of Rock Mass, *Ph. D Thesis*, University of Roorkee, Roorkee, India, 267 p.
- Singh, Bhawani, Goel, R. K., Mehrotra, V. K., Garg, S. K. and Allu, M. R. (1998). Effect of Intermediate Principal Stress on Strength of Anisotropic Rock Mass, *Jr. Tunnelling and Underground Space Technology*, Pergamon, **Vol. 13**, No. 1, pp. 71-79.

CHAPTER - 16

TYPES OF ROCK SLOPE FAILURES

"Real difficulties can be overcome, it is only the imaginary ones that are unconquerable"

Somerset Mougham

16.1 Introduction

The classification of rock slope is based on the mode of failure. In a majority of cases, the slope failures in rock masses are governed by joints and occur across surfaces formed by one or several joints. Some common mode of failures are described below which are frequently found in the field.

16.2 Planar (Translational) Failure

Planar (Translational) failure takes place along prevalent and/or continuous joints dipping towards the slope, with strike nearly parallel ($\pm 15^\circ$) to slope face (Figure 16.1b). Stability condition occurs if

- (i) critical joint dip is less than the slope angle, and
- (ii) mobilized joint shear strength is not enough to assure stability.

Generally, a planar failure depends on joint continuity.

16.3 3D Wedge Failure

Wedge failure occurs along two joints of different sets when these two discontinuities strike obliquely across the slope face and their line of intersection day-lights in the slope face. Figure 16.1c (Hoek & Bray, 1981). The wedge failure depends on joints' attitude and conditions and is more frequent than planar failure. The factor of safety of a rock wedge to slide increases significantly with the decreasing wedge angle for any given dip of the intersection of its two joint planes (Hoek and Bray, 1981).

16.4 Circular (Rotational) Failure

It occurs along a surface which only partially develops along joints, but mainly crosses them. These failure can only happen in heavily jointed rock masses with a very small block size

Types of rock slope failures

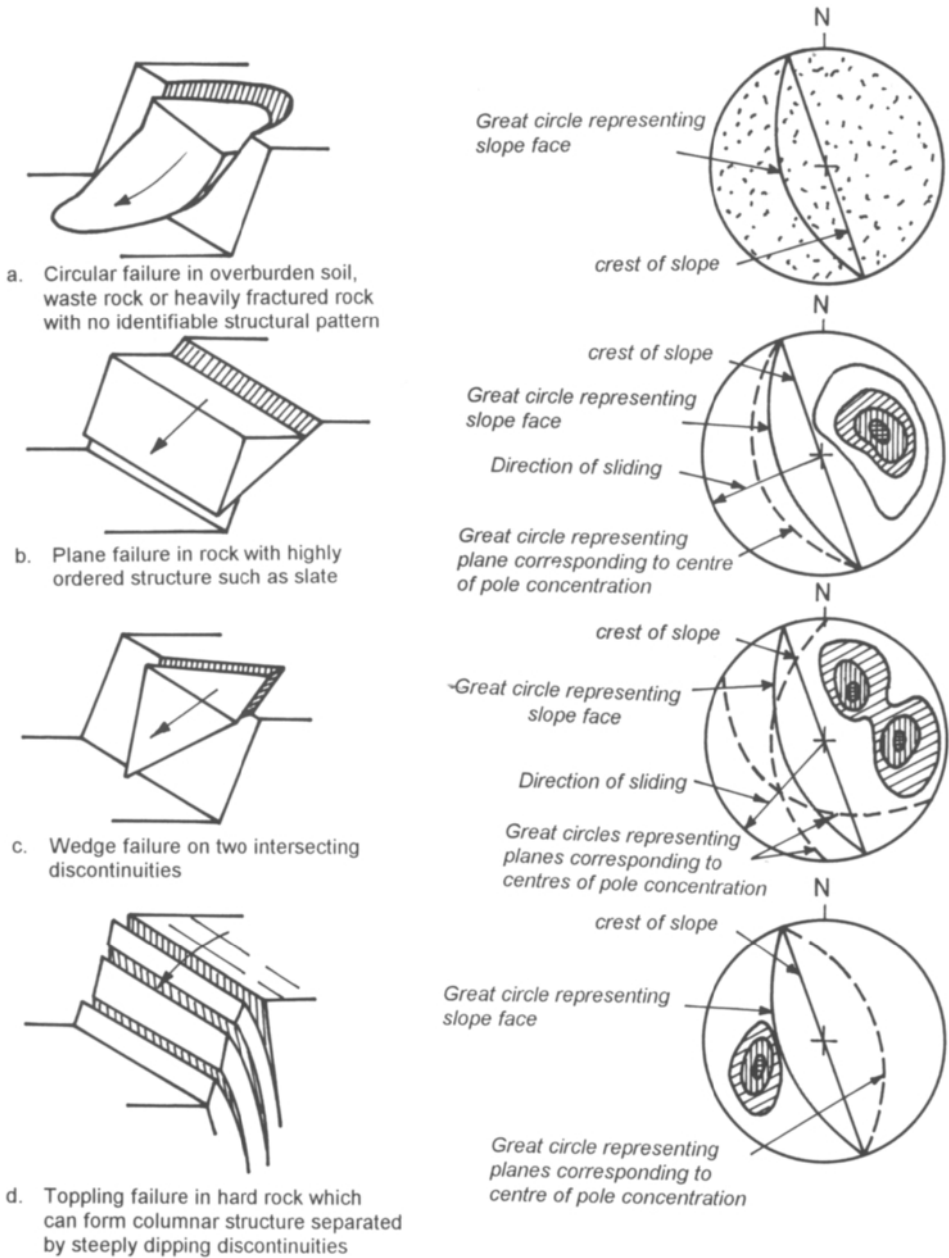

Figure 16.1: Main types of slope failure and stereo plots of structural conditions likely to give rise to these failures (Hoek & Bray, 1981)

and/or very weak or heavily weathered rock (Figure 16.1a). It is essential that all the joints are oriented favourably so that planar and wedge failures are not possible.

The failure modes which have been discussed so far involved the movement of a mass of material upon a failure surface. An analysis of failure or a calculation of the factor of safety for these slopes requires that the shear strength of the failure surface, defined by c and ϕ , be known. There are a few types of slope failures which cannot be analyzed even if the strength of material is known, because failure does not involve simple sliding. These cases are discussed below.

16.5 Toppling Failure (Topples)

Toppling failure with its stereo plot are shown in Figure 16.1d. This mode of rock slope failure is explained as follows.

Consider a block of rock resting on an inclined plane as shown in Figure 16.2a. Here the dimensions of the block are defined by height ' h ' and base length ' b ' and it is assumed that the force resisting the downward movement of the block is friction only, i.e., cohesion is almost zero.

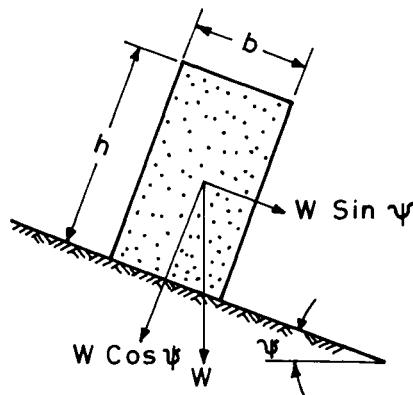

Figure 16.2a: Geometry of block on inclined plane

When the vector representing weight of the block ' W ' falls within the base ' b ', sliding of the block will occur if the inclination of the plane ψ is greater than the angle of friction ϕ . However, when the block is tall and slender ($h > b$), the weight vector W can fall outside the base b and, when this happens, the block will topple, i.e., it will rotate about its lowest contact edge (Hoek and Bray, 1981).

The conditions for sliding and/or toppling for a rock block are defined in Figure 16.2b. The four regions in this diagram are defined as follows :

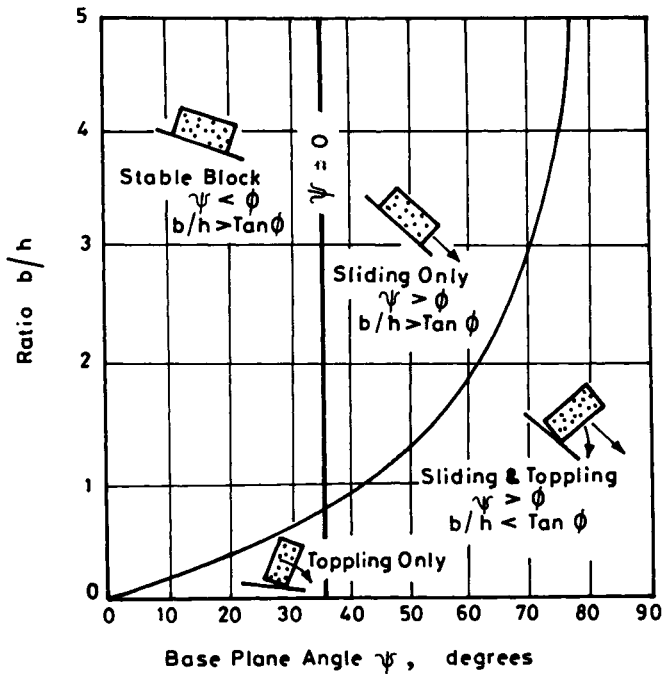

Figure 16.2b: Conditions for sliding and toppling of a block on an inclined plane (Hoek and Bray, 1981)

- Region 1 : $\psi < \phi$ and $b/h > \tan \psi$, the block is stable and will neither slide nor topple
- Region 2 : $\psi > \phi$ and $b/h > \tan \psi$, the block will slide but will not topple
- Region 3 : $\psi < \phi$ and $b/h < \tan \psi$, the block will topple but will not slide
- Region 4 : $\psi > \phi$ and $b/h < \tan \psi$, the block can slide and topple simultaneously

Wedge toppling occurs along a rock wedge where a third joint set intersects the wedge towards the hill side. The process of toppling is slow.

16.6 Ravelling Slopes (Falls)

Accumulation of screens or small pieces of rock which have detached from the rock mass at the base of steep slopes and the cyclic expansion and contraction associated with freezing and thawing of water in cracks and fissures in the rock mass are the principal reasons of slope ravelling. A gradual deterioration of materials which cement the individual rock blocks together may also play a part in this type of slope failure.

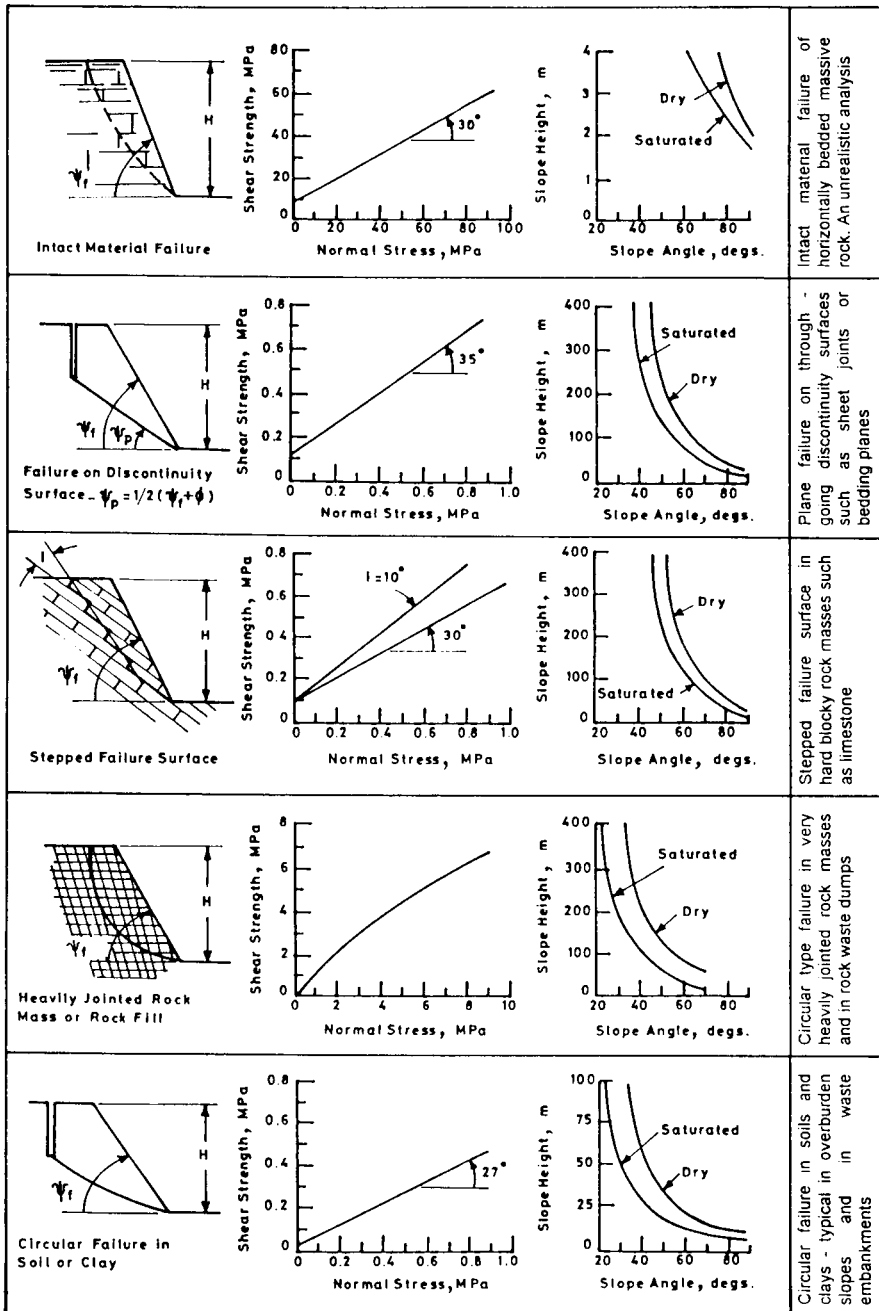

Figure 16.3: Slope angle versus height relationships for different materials (Hock & Bray, 1981)

Types of rock slope failures

Weathering or the deterioration of certain types of rock on exposure, will also give rise to the loosening of a rock mass and the gradual accumulation of materials on the surface which falls at the base of the slope.

It is important that the slope designer should recognize the influence of weathering on the nature of the materials with which he is concerned.

16.7 Effect of Height and Ground Water Conditions on Safe Slope Angle

Figure 16.3 illustrates significant effect of slope height on stable slope angle for various modes of failure. The ground water condition also reduces the factor of safety. University of Roorkee has developed software packages SASP, SASW/WEDGE, SARC and SAST for the analysis of planar, 3D wedge, circular and debris slides respectively (Singh and Anbalagan, 1997)

A few deep seated landslides such as planar and rotational are more catastrophic than millions of surficial landslides along reservoir rims of dams. In the landslide hazard zonation, therefore, potential deep seated landslides should be identified.

16.8 Landslide Classification System

The basic types of landslides/rockslides are summarized in Table 16.1. The landslide are defined as follows:

TABLE 16.1
LANDSLIDE CLASSIFICATION SYSTEM (INDIAN STANDARD CODE)

| Type of Movement | Type of Material | | | Recommended Control Measures |
|------------------|--------------------|----------------------|-------------|---|
| | Soils | | Bedrock | |
| | Predominantly Fine | Predominantly Coarse | | |
| Falls | Earth Fall | Debris Fall | Rock Fall | Geotextile nailed on slope/spot bolting |
| Topples | Earth Topple | Debris Topple | Rock Topple | Breast walls/soil nailing |

TABLE 16.1 (Continued)

| | | | | | |
|-----------------|---------------|--|--------------------|------------------|--|
| Slides | Rotational | Earth Slump | Debris Slump | Rock Slump | Alteration of slope profile and earth & rock fill buttress |
| | Translational | Earth Block Slide | Debris Block Slide | Rock Block Slide | Reinforced earth or rock reinforcement in rock slope |
| | | Earth Slide | Debris Slide | Rock Slide | Biotechnical measures |
| Lateral Spreads | | Earth Spread | Debris Spread | Rock Spread | Check dams along gully |
| Flows | | Earth Flow | Debris Flow | Rock Flow | Series of check dams |
| | | (Soil Creep) | | (Deep Creep) | Rows of deep piles |
| Complex | | Combination of two or more principal types of movement | | | Combined system |

- Debris slide - It is sliding of debris or talus on rock slopes due to a temporary ground water table just after long rains.
- Debris flow - It is liquid flow of mixture of debris, clay and water along gully during rains or cloud burst.
- Earth flow / Mud flow - It is liquid flow of mixture of soil, clay and water along a gully

The landslide control measures may be selected from the last column of Table 16.1.

References

Hoek, E. and Bray, J.W. (1981). *Rock Slope Engineering*, Revised Third Edition, The Institution of Mining and Metallurgy, London, pp. 358.

Indian Standard Code on Landslide Control Guidelines, *Bureau of Indian Standards*, New Delhi, 1998, In Print.

Singh, Bhawani and Anbalagan, R. (1997). Evaluation of Stability of Dam and Reservoir Slopes - Mechanics of Landslide, Seismic Behaviour of Ground and Geotechnical Structures, Proc. Discussion Special Technical Session on Earthquake Geotechnical Engineering, *XIV Int. Conf. on Soil Mech. and Foundation Engg.*, Hamburg, pp. 323-339.

CHAPTER 17

SLOPE MASS RATING (SMR)

17.1 The Slope Mass Rating (SMR)

For evaluating the stability of rock slopes, Romana (1985) proposed a classification system called Slope Mass Rating (SMR) system. Slope mass rating (SMR) is obtained from Bieniawski's Rock Mass Rating (RMR) by subtracting adjustment factors of the joint-slope relationship and adding a factor depending on method of excavation,

$$\text{SMR} = \text{RMR}_{\text{basic}} - (F_1 \cdot F_2 \cdot F_3) + F_4 \quad (17.1)$$

where $\text{RMR}_{\text{basic}}$ is evaluated according to Bieniawski (1979, 1989) by adding the ratings of five parameters (Tables 6.1 to 6.5) as described in Chapter 6. The F_1 , F_2 , and F_3 are adjustment factors related to joint orientation with respect to slope orientation and F_4 is the correction factor for method of excavation. These are defined below:

F_1 depends upon parallelism between joints and slope face strikes. It ranges from 0.15 to 1.0. It is 0.15 in cases when the angle between the critical joint plane and the slope face is more than 30° and the failure probability is very low, whereas it is 1.0 when both are near parallel.

The value of F_1 was initially established empirically, but subsequently it was found to match approximately the following relationship:

$$F_1 = (1 - \sin A)^2 \quad (17.2)$$

where A denotes the angle between the strikes of the slope face and that of the joints ($\alpha_s - \alpha_j$).

F_2 refers to joint dip angle (β_j) in the planar failure mode. Its values also vary from 0.15 to 1.0. It is 0.15 when the dip of the critical joint is less than 20° and 1.0 for joints with dip greater than 45° . For the toppling mode of failure, F_2 remains equal to 1.0.

$$F_2 = \tan \beta_j \quad (17.3)$$

F_3 refers to the relationship between the slope face and joint dips.

In planar failure, F_3 refers to a probability of joints "day lighting" in the slope face. Conditions are called fair when the slope face and the joints are parallel. Where the slope dips 10° more than the joints, the condition is termed very unfavourable. For the toppling failure, unfavourable conditions depend upon the sum of dips of joints and the slope $\beta_j + \beta_s$.

Values of adjustment factors F_1 , F_2 , and F_3 for different joint orientations are given in Table 17.1.

TABLE 17.1
VALUES OF ADJUSTMENT FACTORS FOR DIFFERENT JOINT ORIENTATIONS
(ROMANA, 1985)

| Case of Slope Failure | | Very Favourable | Favourable | Fair | Unfavourable | Very Unfavourable |
|-----------------------|---|-----------------|-------------------|-----------------|-------------------|-------------------|
| P T W | $ \alpha_j - \alpha_s $ $ \alpha_j - \alpha_s - 180^\circ $ $ \alpha_i - \alpha_s $ | $>30^\circ$ | $30 - 20^\circ$ | $20 - 10^\circ$ | $10 - 5^\circ$ | $<5^\circ$ |
| P/W/T | F₁ | 0.15 | 0.40 | 0.70 | 0.85 | 1.00 |
| P W | $ \beta_j $ $ \beta_i $ | $<20^\circ$ | $20 - 30^\circ$ | $30 - 35^\circ$ | $35 - 45^\circ$ | $>45^\circ$ |
| P/W | F₂ | 0.15 | 0.40 | 0.70 | 0.85 | 1.00 |
| T | F₂ | 1.0 | 1.0 | 1.0 | 1.0 | 1.0 |
| P W | $ \beta_j - \beta_s $ $ \beta_i - \beta_s $ | $>10^\circ$ | $10 - 0^\circ$ | 0° | $0 - (-10^\circ)$ | $< -10^\circ$ |
| T | $ \beta_j + \beta_s $ | $<110^\circ$ | $110 - 120^\circ$ | $>120^\circ$ | -- | -- |
| P/W/T | F₃ | 0 | -6 | -25 | -50 | -60 |

NOTATIONS: P - planar failure; T - toppling failure; W - wedge failure; α_s - slope strike; α_j - joint strike; α_i - plunge direction of line of intersection; β_s - slope dip and β_j - joint dip (see Figure 17.1); β_i - plunge of line of intersection

F_4 pertains to the adjustment for the method of excavation. It includes the natural slope, or the cut slope excavated by pre-splitting, smooth blasting, normal blasting, poor blasting and mechanical excavation (see Table 17.2 for adjustment rating F_4 for different excavation methods).

Natural slopes, are more stable, because of long time erosion and built in protection mechanism (vegetation, crust dessication), $F_4 = +15$.

Normal blasting applied with sound methods does not change slope stability conditions and therefore $F_4 = 0$.

Slope mass rating (SMR)

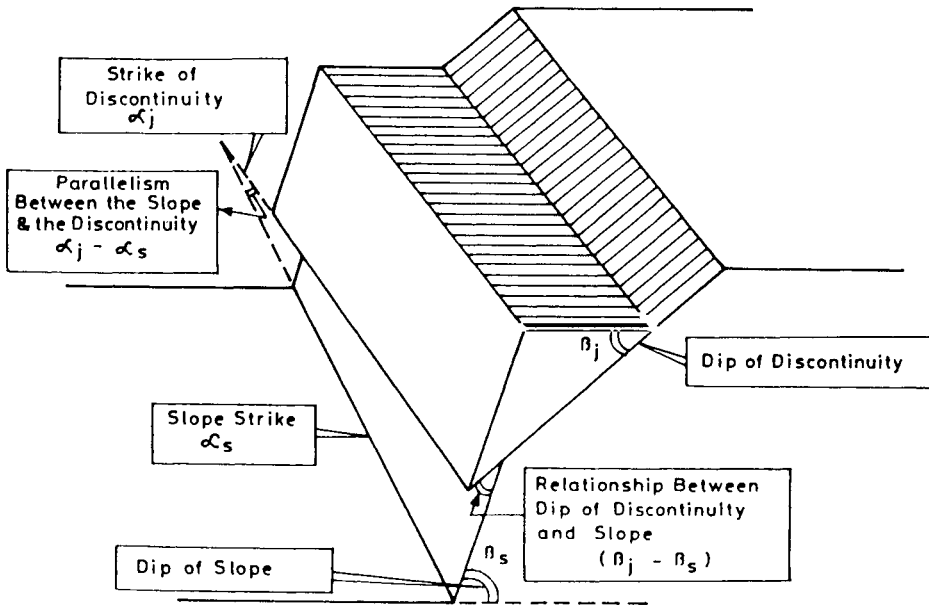

Figure 17.1: Planar failure

TABLE 17.2
VALUES OF ADJUSTMENT FACTOR F_4 FOR METHOD OF
EXCAVATION (ROMANA, 1985)

| Method of Excavation | F_4 Value |
|--|-------------|
| Natural slope | +15 |
| Pre-splitting | +10 |
| Smooth blasting | +8 |
| Normal blasting or Mechanical excavation | 0 |
| Poor blasting | -8 |

Deficient blasting or poor blasting damages the slope stability, therefore $F_4 = -8.0$.

Mechanical excavation of slopes, usually by ripping, can be done only in soft and or very fractured rock, and is often combined with some preliminary blasting. The plane of slope is difficult to finish. The method neither increases nor decreases slope stability, therefore $F_4 = 0$.

The minimum and maximum values of SMR from Eqn. 17.1 are 0 and 100 respectively. It is needless to mention here that the slope stability problem is not found in areas where the discontinuities are steeper than the slope. Therefore, this condition is not considered in the empirical approach.

Romana (1985) used planar and toppling failures for his analysis. The wedge failures have been considered as a special case of plane failures and analysed in forms of individual planes and the minimum value of SMR is taken for assessing the rock slopes. Experience shows that dip β_i and dip direction α_i of the intersection of these planes should be taken as β_j and α_j respectively, i.e., $\beta_j = \beta_i$ and $\alpha_j = \alpha_i$ where wedge failure is likely to occur (Figure 17.2).

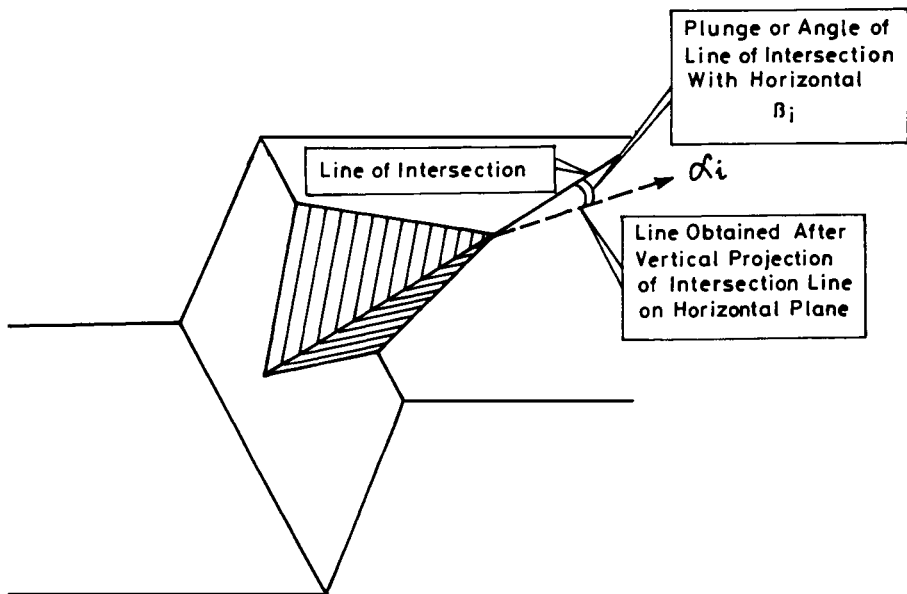

Figure 17.2: Wide angle wedge failure

Effect of weathering on the slope stability cannot be assessed with rock mass classification as it is a temporary process which depends mostly on the mineralogical conditions of rock, and the climate. In certain rock masses, e.g., some marls, clays and shales, the slopes are stable when excavated but fail sometime afterwards (usually one to two years later). In such conditions, it is suggested that the classification should be applied twice: initially for fresh and afterwards for weathered conditions.

Water conditions govern the stability of many slopes which are stable in summer and fail in winter because of heavy raining or freezing. The worst possible water conditions must be assumed for analysis.

Slope mass rating (SMR)

17.2 Slope Stability Classes

According to the SMR values, Romana (1985) defined five stability classes. These are described in Table 17.3.

TABLE 17.3
VARIOUS STABILITY CLASSES AS PER SMR VALUES (ROMANA, 1985)

| Class No. | V | IV | III | II | I |
|------------------------|-------------------------------------|----------------------|---|--------------------|-------------------|
| SMR Value | 0 - 20 | 21 - 40 | 41 - 60 | 61 - 80 | 81 - 100 |
| Rock Mass Description | Very bad | Bad | Normal | Good | Very good |
| Stability | Completely unstable | Unstable | Partially stable | Stable | Completely stable |
| Failures | Big planar or soil like or circular | Planar or big wedges | Planar along some joint and many wedges | Some block failure | No failure |
| Probability of Failure | 0.9 | 0.6 | 0.4 | 0.2 | 0 |

It is inferred from Table 17.3 that the slopes with SMR value below 20 may fail very quickly. No slope has been registered with SMR value below 10 because such slopes would not be physically existing.

The stability of slope also depends upon length of joints along slope. Table 17.3 is found to over-estimate SMR where length of joint along slope is less than 5 percent of the affected height of the landslide. SMR is also not found to be applicable to opencast mines because heavy blasting creates new fractures in the rock slope and depth of cut slope is also large.

Slope mass rating is being used successfully for landslide zonation in rocky and hilly areas. Detailed studies should be carried out where SMR is less than 40 and life and property is in danger and slopes should be stabilized accordingly. Otherwise, a safe cut slope angle should be determined to raise SMR to 60.

17.3 Support Measures

Many remedial measures can be taken to support a slope. Both detailed study and good engineering sense are necessary to stabilize a slope. Classification systems can only try to point the normal techniques for each different class of support as given in Table 17.4.

TABLE 17.4
SUGGESTED SUPPORTS FOR VARIOUS SMR CLASSES

| SMR Classes | SMR Values | Suggested Supports |
|-------------|------------|--|
| Ia | 91-100 | None |
| Ib | 81-90 | None, scaling is required |
| IIa | 71-80 | (None, toe ditch or fence), spot bolting |
| IIb | 61-70 | (Toe ditch or fence nets), spot or systematic bolting |
| IIIa | 51-60 | (Toe ditch and/or nets), spot or systematic bolting, spot shotcrete |
| IIIb | 41-50 | (Toe ditch and/or nets), systematic bolting/anchors, systematic shotcrete, toe wall and/or dental concrete |
| IVa | 31-40 | Anchors, systematic shotcrete, toe wall and/or concrete (or re-excavation), drainage |
| IVb | 21-30 | Systematic reinforced shotcrete, toe wall and/or concrete, re-excavation, deep drainage |
| Va | 11-20 | Gravity or anchored wall, re-excavation |

(Less popular support measures are given in brackets in Table 17.4)

In a broader sense, the SMR range for each group of support measures are the following :

| | |
|------------|------------------------------|
| SMR 65-100 | None, Scaling |
| SMR 30-75 | Bolting, Anchoring |
| SMR 20-60 | Shotcrete, Concrete |
| SMR 10-30 | Wall erection, Re-excavation |

As pointed out by Romana (1985), wedge failure has not been discussed in his SMR classification separately. To overcome this problem, Anbalagan et al. (1992) has modified SMR to make it applicable for wedge mode of failure also. This modification is presented in the following paragraphs.

17.4 Modified SMR Approach

Though the SMR accounts for planar and toppling failures in rock slopes, in the case of wedge failure it takes into consideration different planes forming the wedges and analysing the different planes individually. The unstable wedge is a result of combined effect of the intersection of various joints (Figure 17.2). Anbalagan, Sharma and Raghuvanshi (1992) considered plane and wedge failures as different cases and presented a modified SMR approach for slope stability analysis.

In the modified SMR approach, the same method is applicable for planar failures and the strike and the dip of the plane are used for the analysis. But in the case of wedge failures, the plunge and the direction of line of intersection of the unstable wedge are used. Thin wedges with low angle are likely to be stable and should not be considered. In Table 17.1, adjustment

Slope mass rating (SMR)

ratings for F_1 , F_2 , and F_3 are also given in the case of wedge failure as suggested by Anbalagan et al. (1992).

For example: Consider two joint sets having dips of 45° and 35° and dip directions of 66° and 325° respectively. The inclination of slope is $N10^\circ/50^\circ$. The plunge and trend of line of intersection of these two joints forming wedge are 28° and 4° respectively (Figure 17.3).

TABLE 17.5
CALCULATIONS FOR ADJUSTMENT FACTORS F_1 , F_2 AND F_3

| A. Details of Geological Discontinuities | | | | | |
|---|---|-----------------|------------|-------|--|
| | | Dip Direction | Dip | | |
| Joint J_1 | | N 60° | 45° | | |
| Joint J_2 | | N 325° | 35° | | |
| Slope | | N 10° | 50° | | |
| B. Details of Line of Intersection of J_1 and J_2 | | | | | |
| Trend = | 4° | See Figure 17.3 | | | |
| Plunge = | 28° | | | | |
| C. Adjustment Factor F_1 , F_2 , and F_3 for Different Conditions | | | | | |
| No. | Condition | F_1 | F_2 | F_3 | Adjustment Factor ($F_1 \cdot F_2 \cdot F_3$) |
| 1. | Considering joint J_1 and slope | 0.15 | 0.85 | -50 | -6.4 |
| 2. | Considering joint J_2 and slope | 0.15 | 0.70 | -60 | -6.3 |
| 3. | Considering the plunge and trend of line of intersection of J_1 and J_2 and the slope (modified SMR approach) | 0.85 | 0.40 | -60 | -20.4 |

According to SMR approach, SMR value for the above two joint sets are worked out separately and the critical value of SMR is adopted for classification purpose. According to this approach, adjustment factor (F_1 , F_2 , F_3) for the first joint set and the slope works out as -6.4 (Table 17.5). Similarly, considering the second joint set and slope, the adjustment factor works out as -6.3 (Table 17.5). Now, if we consider the plunge and the trend of the wedge formed by the two joint sets and the slope, the adjustment factor works out as -20.4. This clearly shows that the SMR calculated for the third case is more critical than the first and the second cases. Therefore, it is more logical and realistic to use the plunge and the trend of line of intersection for potential wedge failure.

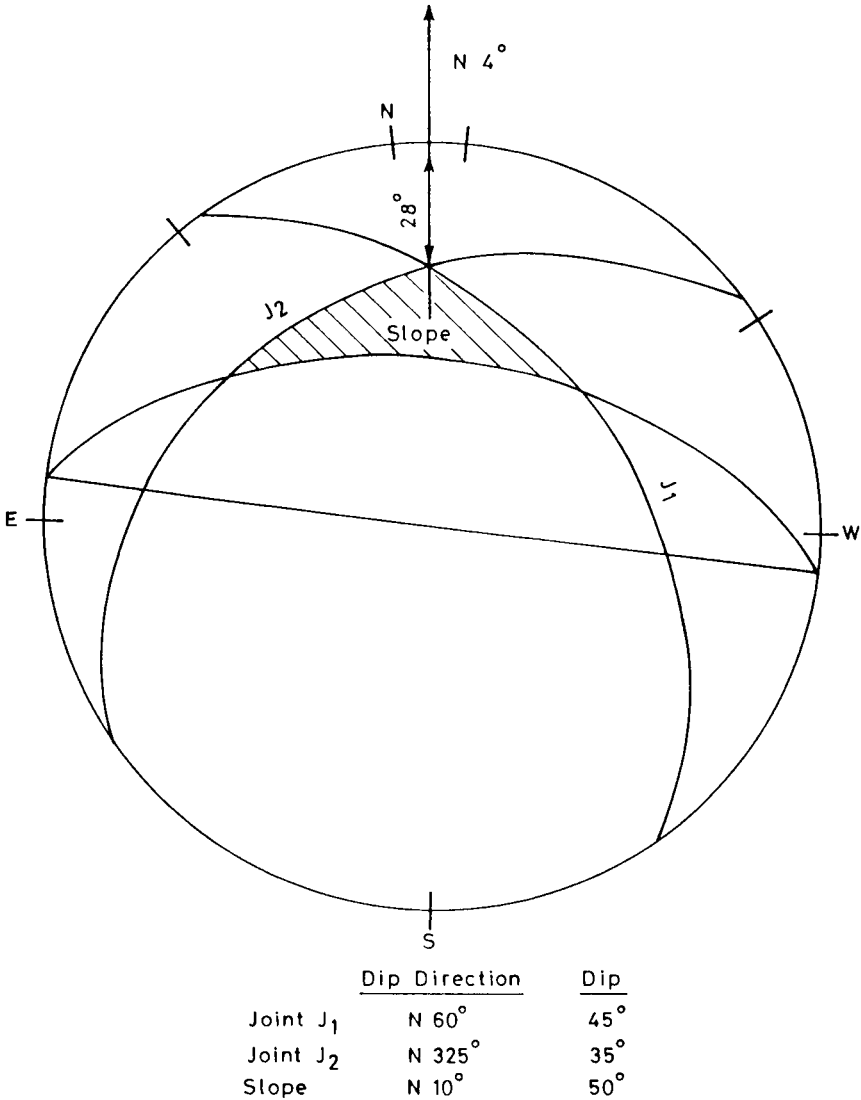

Figure 17.3: Usage of stereo plot for identifying the wedge

17.5 Case Study of Stability Analysis Using Modified SMR Approach

Anbalagan, Sharma and Raghuvanshi (1992) have analysed 20 different slopes using modified SMR approach along the Lakshmanjhula-Shivpuri road in the lesser Himalayas of Distt. Garhwal, U. P., India.

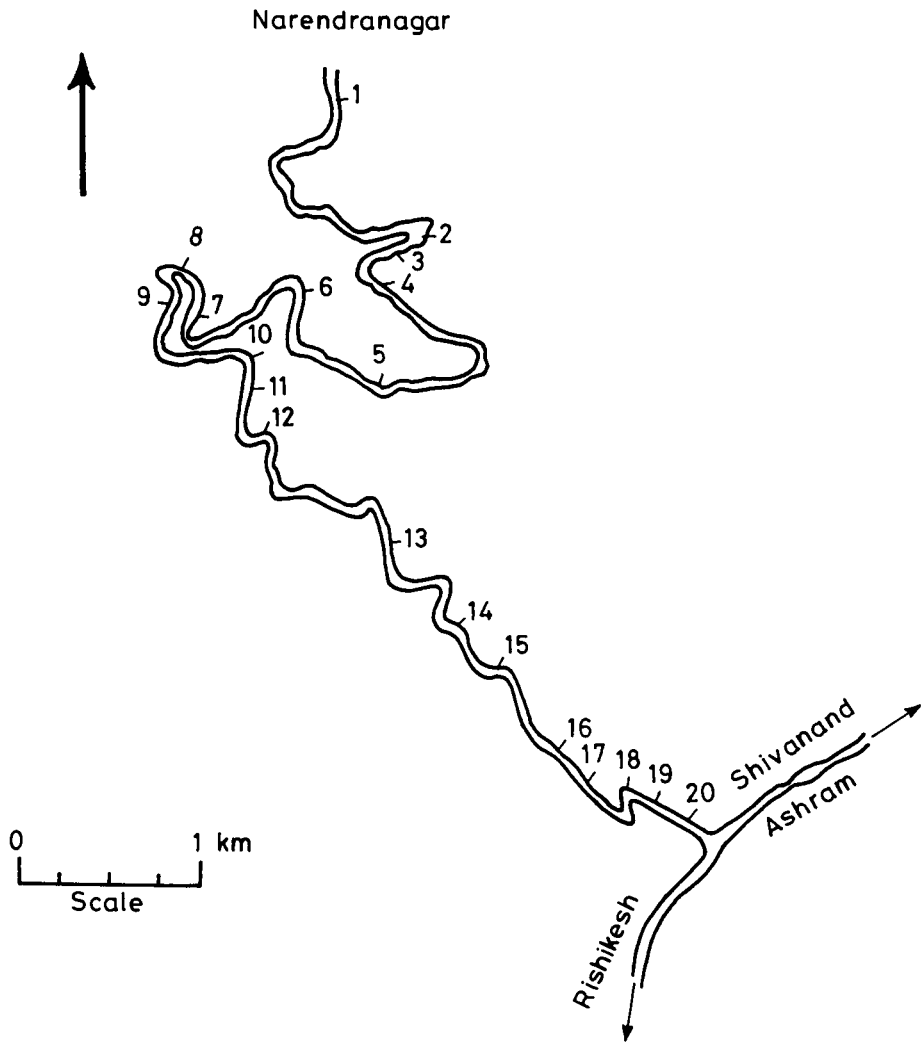

Figure 17.4: Location map of slope stability study

17.5.1 Geology

The Lakshmanjhula-Shivpuri road section area forms the northern part of Garhwal syncline. The road section has encountered Infra-Krol formation. Krol 'A', Krol 'B', Krol 'C+D' formations, lower Tal formation, upper Tal formation and Blaini formation. The rocks are folded in the form of a syncline called Narendra Nagar syncline. The axis of the syncline is

aligned in NE - SW direction so that the sequence of Blaini and Tal formations from Lakshmanjhula are repeated again to the north of the syncline axis.

The Infra Krol formation mainly consists of dark grey shales while Krol A consists of shaly limestones and Krol B includes red shales. The Krol C+D comprises gypsiferous limestones. The lower Tal formation consists of shales, whereas the upper Tal comprises of quartzites. The rocks of Blaini formation exposed near Shivpuri include laminated shales.

17.5.2 Rock Slope Analysis

Twenty rock slopes along the road were chosen such that they cover different rock types (Figure 17.4). The RMR_{basic} for different rock types were estimated (Table 17.6). The graphical analysis is performed for the joints to deduce the mode of failure. In this method, the poles of discontinuities were plotted on an equal area stereonet and contours were drawn to get the maxima of pole concentrations. The probable failure patterns were determined by studying the orientation of various joints and the intersection and comparing the same with the slope. The graphical analysis of individual slope has been shown in Figures 17.5a and 17.5b. The result of SMR approach has been given in Table 17.7.

It may be noted that the modified approach for wide angle wedge failure appears to be valid as SMR predictions matched with the observed failure modes. However, for identifying potentially unstable wedges, one should use the judgement.

TABLE 17.6
ROCK MASS RATING (RMR) FOR VARIOUS ROCK TYPES OF LAKSHMANJHULA-
SHIVPURI AREA (ANBALAGAN ET AL., 1992)

| Rock Type | Uniaxial Compressive Strength | RQD from J_y | Joint Spacing | Joint Condition | Ground Water Condition | RMR_{basic} |
|---------------------------|-------------------------------|----------------|---------------|-----------------|------------------------|---------------|
| Infra Krol shales | 7 | 13 | 8 | 22 | 15 | 65 |
| Krol 'A' shaly limestones | 12 | 13 | 8 | 22 | 15 | 70 |
| Krol 'B' shales | 12 | 13 | 8 | 22 | 15 | 70 |
| Krol 'C + D' limestones | 12 | 13 | 8 | 22 | 15 | 70 |
| Lower Tal shales | 7 | 13 | 8 | 22 | 15 | 65 |
| Upper Tal quartzites | 12 | 17 | 10 | 22 | 15 | 76 |
| Blaini shales | 7 | 13 | 8 | 22 | 15 | 65 |

Slope mass rating (SMR)

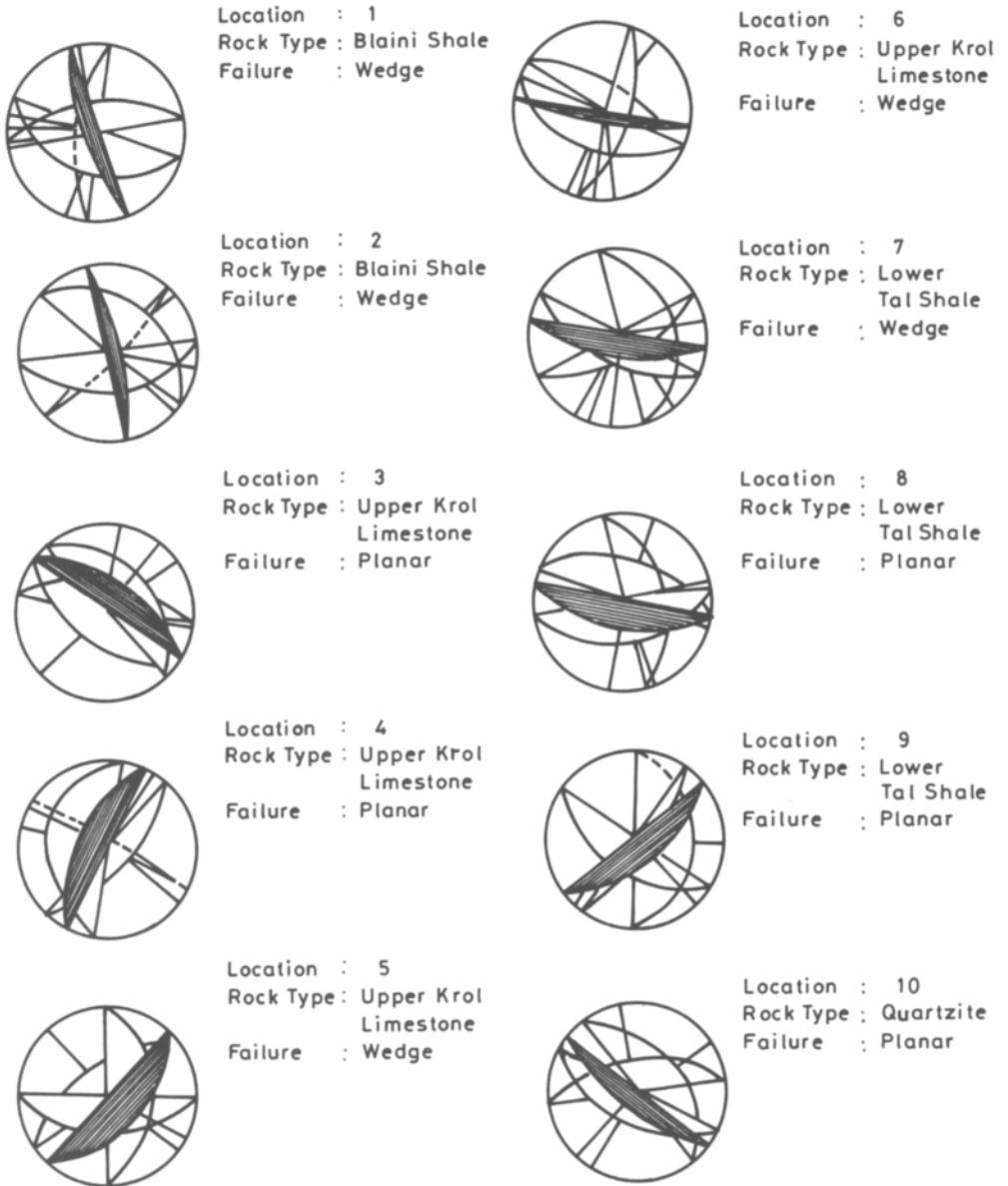

Figure 17.5a: Stability analysis of wedge/planar failure (Anbalagan et al., 1992)

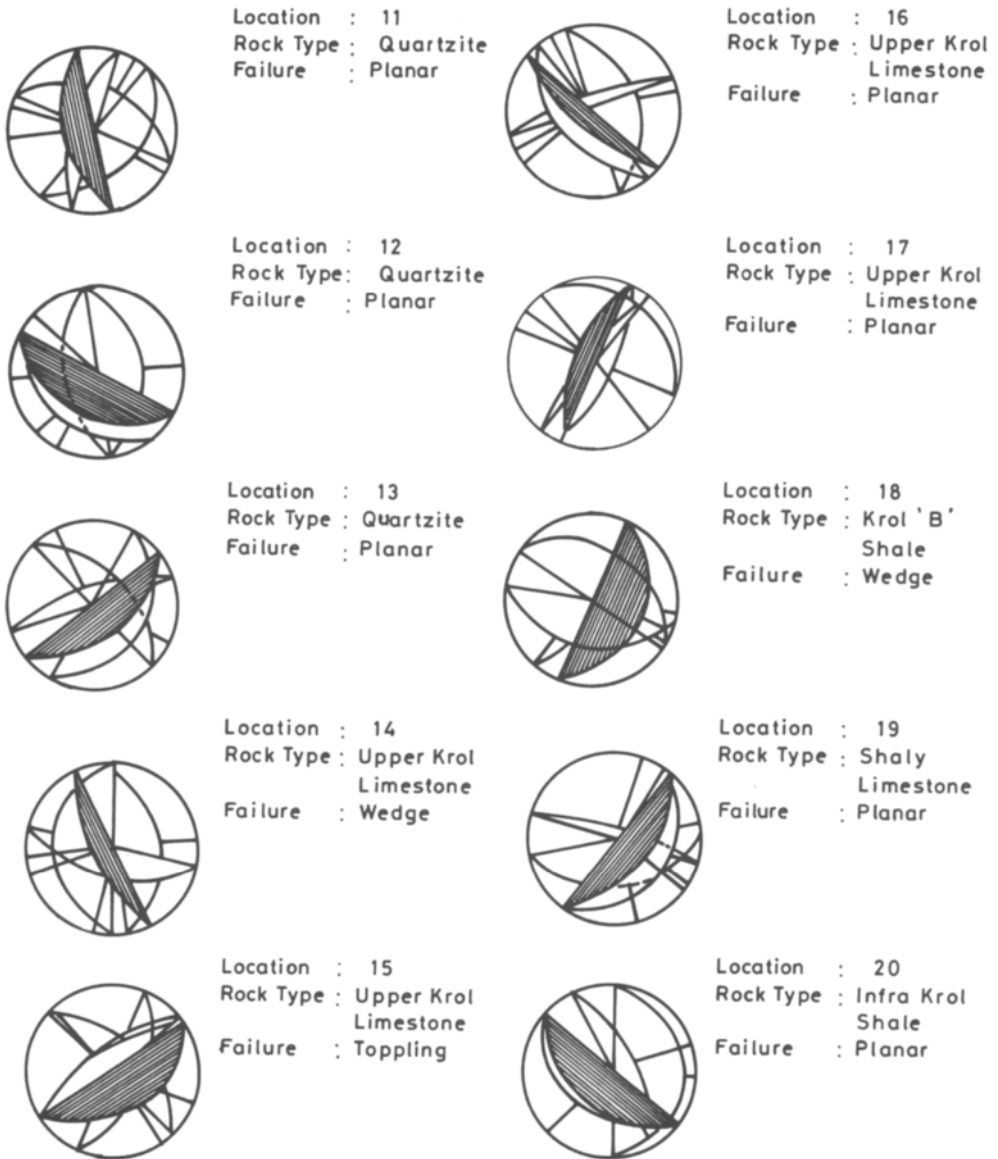

Figure 17.5b: Stability analysis of wedge/planar failure (Anbalagan et al., 1992)

Slope mass rating (SMR)

TABLE 17.7
SLOPE STABILITY ANALYSIS ALONG LAKSHMANJHULA-SHIVPURI AREA
(ANBALAGAN ET AL., 1992)

| Location No. (Figure 17.4) | SMR Value | Class No. | Slope Description | Stability | Observed Failure |
|----------------------------|-----------|-----------|-------------------|---------------------|-----------------------------|
| 1. | 44.2 | III | Normal | Partially stable | Wedge failure |
| 2. | 47.8 | III | Normal | Partially stable | Wedge failure |
| 3. | 36.3 | IV | Bad | Unstable | Planar failure |
| 4. | 32.4 | IV | Bad | Unstable | Planar failure |
| 5. | 18.0 | V | Very bad | Completely unstable | Big wedge failure |
| 6. | 24.0 | IV | Bad | Unstable | Planar or big wedge failure |
| 7. | 26.0 | IV | Bad | Unstable | Wedge failure |
| 8. | 40.6 | III | Normal | Partially stable | Planar failure |
| 9. | 56.8 | III | Normal | Partially stable | Planar failure |
| 10. | 30.0 | IV | Bad | Unstable | Planar failure |
| 11. | 69.6 | II | Good | Stable | Some block failure |
| 12. | 55.2 | III | Normal | Partially stable | Planar failure |
| 13. | 51.6 | III | Normal | Partially stable | Planar failure |
| 14. | 36.6 | IV | Bad | Unstable | Wedge failure |
| 15. | 60.9 | II | Good | Stable | Some block failure |
| 16. | 24.0 | IV | Bad | Unstable | Planar failure |
| 17. | 61.8 | II | Good | Stable | Some block failure |
| 18. | 57.0 | III | Normal | Partially stable | Wedge failure |
| 19. | 22.65 | IV | Bad | Unstable | Planar failure |
| 20. | 18.5 | V | Very Bad | Completely unstable | Big planar failure |

References

- Anbalagan, R., Sharma, Sanjeev and Raghuvanshi, T. K. (1992). Rock Mass Stability Evaluation Using Modified SMR Approach, *Proc. 6th Nat. Sym. on Rock Mech.* Bangalore, India. pp.258-268.
- Bieniawski, Z. T. (1979). The Geomechanics Classification in Rock Engineering Applications, Reprinted from: *Proc. 4th Cong. of the Int. Society for Rock Mech./ Comptes-rendus/ Berichte-Montreux, Suisse*, 2-8 Sept. 1979. 2208 pp., 3 vols., Hfl. 1390/-, US\$695.00/£463. A. A. Balkema, P.O. Box 1675, Rotterdam, Netherlands.
- Bieniawski, Z. T. (1989). *Engineering Rock Mass Classifications*. John Wiley, p. 251.
- Romana, M. (1985). New Adjustment Ratings for Application of Bieniawski Classification to Slopes, *Int. Sym. on the Role of Rock Mechanics*, Zacatecas, pp.49-53.

LANDSLIDE HAZARD ZONATION

"Landslide is a mountain cancer. It is cheaper to cure than to endure it"

18.1 Introduction

Landslide hazard zonation (LHZ) map is an important tool for designers, field engineers and geologists, to classify the land surface into zones of varying degree of hazards based on the estimated significance of causative factors which influence the stability (Anbalagan, 1992). The landslide hazard zonation map, in short called LHZ map, is a rapid technique of hazard assessment of the land surface (Gupta and Anbalagan, 1995). It is useful for the following purposes:

- (i) The LHZ maps help the planners and field engineers to identify the hazard prone areas and therefore enable one to choose favourable locations for site development schemes. In case the site cannot be changed and it is hazardous, the zonation before construction helps to adopt proper precautionary measures to tackle the hazard problems.
- (ii) These maps identify and delineate the hazardous area of instability for adopting proper remedial measures to check further environmental degradation of the area.
- (iii) Geotechnical monitoring of structures on the hills should be done specially in the hazardous areas by preparing contour map of displacement rates. Landslide control measures and construction controls may be identified accordingly for safety of buildings on the hilly areas.
- (iv) Tunnels should be realigned to avoid regions of deep-seated major landslides to eliminate risks of high displacement rate. The tunnel portals should be relocated in the stable rock slope. The outlet of the tail race tunnel of a hydroelectric project should be much above flood level in the deep gorges which are prone to landslide.

Based on the scale of LHZ maps, these are classified into three categories.

- (i) Mega - Regional - Scale of 1:50,000 or more
- (ii) Macro - Zonation and Risk Zonation - 1:25,000 to 1:50,000
- (iii) Micro - Zonation - Scale of 1:2,000 to 1:10,000

Methodology of preparing the LHZ map is described in the following paragraphs with an example to show the method of applying LHZ mapping technique in the field for demarcating the landslides prone areas.

18.2 Landslide Hazard Zonation Maps - The Methodology

18.2.1 Factors

The technique of landslide hazard zonation has been developed by Anbalagan (1992). Many researchers have developed various methods of landslide zonation but they are not based on causative factors. The main merit of Anbalagan's method is that it considers causative factors in a simple way. His method has become very popular in India, Italy, Nepal and other countries. The technique in broader sense, classifies the area into five zones on the basis of the following six major causative factors.

- (i) Lithology - To consider the rock and land type
- (ii) Structure - Relationship of structural discontinuities with slopes
- (iii) Slope Morphometry
- (iv) Relative Relief - Height of slope
- (v) Land Use and Land Cover
- (vi) Ground Water Condition

These factors have been called as Landslide Hazard Evaluation Factors (LHEF). Ratings of all the Landslide Hazard Evaluation Factors (LHEF) are given in Table 18.1, whereas the maximum assigned rating to each LHEF is given in Table 18.2. The basis of assigning ratings in Table 18.1 is discussed parameter wise below.

Lithology

The erodibility or the response of rocks to the processes of weathering and erosion should be the main criterion in awarding the ratings for lithology. The rock types such as unweathered quartzites, limestones and granites are generally hard and massive and more resistant to weathering, and therefore form steep slopes. Whereas, ferruginous sedimentary rocks are more vulnerable to weathering and erosion. The phyllites and schists are generally more weathered close to the surface. Accordingly, higher rating, i.e., LHEF ratings should be awarded (Table 18.1).

In case of soil-like materials, the genesis and age are the main considerations in awarding the ratings. The older alluvium is generally well compacted and has high strength whereas slide debris is generally loose and has low shearing resistance.

Structure

This includes primary and secondary rock discontinuities, such as bedding planes, foliations, faults and thrusts. The discontinuities in relation to slope direction has greater influence on the slope stability. The following three types of relations are important:

- (i) The extent of parallelism between the directions of discontinuity or the line of intersection of two discontinuities and the slope.

TABLE 18.1
 LANDSLIDE HAZARD EVALUATION FACTOR (LHEF) RATING SCHEME
 (GUPTA AND ANBALAGAN, 1995)

| S. No. | Contributory Factor | Category | Rating | Remarks |
|--------|--|--|-------------------|---|
| 1. | Lithology (a) <i>Rock Type</i> | <i>Type - I</i> - Quartzite & Limestone - Granite & Gabbro - Gneiss | 0.2 0.3 0.4 | <p><i>Correction factor for weathering:</i></p> <p>(a) Highly weathered - rock discolored joints open with weathering products, rock fabric altered to a large extent; correction factor C_1</p> <p>(b) Moderately weathered - rock discolored with fresh rock patches, weathering more around joint planes but rock intact in nature; correction factor C_2</p> <p>(c) Slightly weathered - rock slightly discolored along joint planes, which may be moderately tight to open, intact rock; correction factor C_3</p> <p>The correction factor for weathering should be multiple with the fresh rock rating to get the corrected rating</p> <p><i>For rock type I</i> $C_1 = 4, C_2 = 3, C_3 = 2$</p> <p><i>For rock type II</i> $C_1 = 1.5, C_2 = 1.25, C_3 = 1.0$</p> |
| | | <i>Type - II</i> - Well cemented ferruginous sedimentary rocks, dominantly sandstone with minor beds of claystone | 1.0 | |
| | | - Poorly cemented ferruginous sediment-ary rocks, dominantly sandstone with minor clay shale beds | 1.3 | |
| | | <i>Type - III</i> - Slate & phyllite | 1.2 | |
| | | - Schist | 1.3 | |
| | | - Shale with interbedded clayey & nonclayey rocks | 1.8 | |
| | | - Highly weathered shale, phyllite & schist | 2.0 | |
| | (b) <i>Soil Type</i> | - Older well compacted fluvial fill material (alluvial) | 0.8 | |
| | | - Clayey soil with naturally formed surface (alluvial) | 1.0 | |
| | | - Sandy soil with naturally formed surface (alluvial) | 1.4 | |
| | | - Debris comprising mostly rock pieces mixed with clayey / sandy soil (colluvial) | | |
| | | I. older well compacted | 1.2 | |
| | | II. younger loose material | 2.0 | |

TABLE 18.1 (Continued)

| | | | | |
|----|--|---|--|--|
| 2. | <p>Structure</p> <p>(a) <i>Parallelism between the slope & discontinuity*</i></p> <p>PLANAR ($\alpha_j - \alpha_s$)</p> <p>WEDGE ($\alpha_j - \alpha_s$)</p> <p>(b) <i>Relationship of dip of discontinuity and inclination</i></p> <p>PLANAR ($\beta_j - \beta_s$)</p> <p>WEDGE ($\beta_j - \beta_s$)</p> <p>(c) <i>Dip of discontinuity:</i></p> <p>PLANAR (β_j)</p> <p>WEDGE (β_j)</p> | <p>I. > 30°</p> <p>II. 21 - 30°</p> <p>III. 11 - 20°</p> <p>IV. 6 - 10°</p> <p>V. < 5°</p> <p>I. > 10°</p> <p>II. 0 - 10°</p> <p>III. 0°</p> <p>IV. 0 - (-10°)</p> <p>V. < - 10°</p> <p>I. < 15°</p> <p>II. 16 - 25°</p> <p>III. 26 - 35°</p> <p>IV. 36 - 45°</p> <p>V. > 45°</p> | <p>0.2</p> <p>0.25</p> <p>0.3</p> <p>0.4</p> <p>0.5</p> <p>0.3</p> <p>0.5</p> <p>0.7</p> <p>0.8</p> <p>1.0</p> <p>0.2</p> <p>0.25</p> <p>0.3</p> <p>0.4</p> <p>0.5</p> | <p>α_j = dip direction of joint</p> <p>α_i = direction of line of intersection of two discontinuities</p> <p>α_s = direction of slope inclination</p> <p>β_j = dip of joint</p> <p>β_i = plunge of line of intersection</p> <p>β_s = inclination of slope</p> <p><u>Category:</u></p> <p>I = very favourable</p> <p>II = favourable</p> <p>III = fair</p> <p>IV = unfavourable</p> <p>V = very unfavourable</p> |
| 3. | <p>Slope Morphometry</p> <p>- Escarpment/cliff</p> <p>- Steep slope</p> <p>- Moderately steep slope</p> <p>- Gentle slope</p> <p>- Very gentle slope</p> | <p>> 45°</p> <p>36 - 45°</p> <p>26 - 35°</p> <p>16 - 25°</p> <p>< 15°</p> | <p>2.0</p> <p>1.7</p> <p>1.2</p> <p>0.8</p> <p>0.5</p> | |
| 4. | <p>Relative Relief</p> <p>Low</p> <p>Medium</p> <p>High</p> | <p>< 100 m</p> <p>101 - 300 m</p> <p>> 300 m</p> | <p>0.3</p> <p>0.6</p> <p>1.0</p> | |
| 5. | <p>Land Use and Land Cover</p> <p>-Agriculture land / populated flat land</p> <p>-Thickly vegetated area</p> <p>-Moderately vegetated</p> <p>-Sparsely vegetated with lesser ground cover</p> <p>-Barren land</p> <p>-Depth of soil cover</p> | <p>< 5m</p> <p>6 - 10m</p> <p>11 - 15m</p> <p>16 - 20m</p> <p>> 20m</p> | <p>0.65</p> <p>0.90</p> <p>1.2</p> <p>1.2</p> <p>2.0</p> <p>0.65</p> <p>0.85</p> <p>1.3</p> <p>2.0</p> <p>1.2</p> | |

TABLE 18.1 (Continued)

| | | | | | |
|----|-------------------------|--------------|----------|-----|--|
| 6. | Ground Condition | Water | Flowing | 1.0 | |
| | | | Dripping | 0.8 | |
| | | | Wet | 0.5 | |
| | | | Damp | 0.2 | |
| | | | Dry | 0.0 | |

* Discontinuity refers to the planar discontinuity or the line of intersection of two planar discontinuities, whichever is important concerning instabilities

Note: In regions of low seismicity (1, 2, and 3 zones), the maximum rating for relative relief may be reduced to 0.5 times and that of hydrogeological conditions be increased to 1.5 times (Table 18.1). For high seismicity (4 and 5 zones), no corrections are required.

TABLE 18.2

PROPOSED MAXIMUM LHEF RATING FOR DIFFERENT CONTRIBUTORY FACTORS FOR LHZ MAPPING (GUPTA AND ANBALAGAN, 1995)

| Contributory Factor | Maximum LHEF Rating |
|--|---------------------|
| Lithology | 2 |
| Structure - relationship of structural discontinuities with slopes | 2 |
| Slope Morphometry | 2 |
| Relative Relief | 1 |
| Land use and Land Cover | 2 |
| Ground Water Condition | 1 |
| Total | 10 |

- (ii) Steepness of the dip of discontinuity or plunge of the line of intersection of two discontinuities.
- (iii) The difference in the dip of discontinuity or plunge of the line of intersection of two discontinuities of the slope.

The above three relations are same as that of F_1 , F_2 and F_3 of Romana (1985) and discussed in Chapter 17. Various sub-classes of the above conditions are also more or less similar to Romana (1985).

It may be noted that the inferred depth, in case of soil, should be considered for awarding the ratings.

Landslide hazard zonation

Slope morphometry

Slope Morphometry defines the slope categories on the basis of frequency of occurrence of particular slope angle. Five categories representing the slopes of escarpment/cliff, steep slope, moderately steep slope, gentle slope and very gentle slope are used in preparing slope morphometry maps. On regional basis, for initial study, the angle can be obtained from topo sheets.

Relative relief

Relative relief map represents the local relief of maximum height between the ridge top and the valley floor within an individual facet. Three categories of slopes of relative relief namely low, medium and high should be used for hazard evaluation purposes.

A facet is a part of hill slope which has more or less similar characters of slope showing consistent slope direction and inclination.

Land use and land cover

The nature of land cover is an indirect indication of hill slope stability. Forest cover, for instance, protects slopes from the effects of weathering and erosion. A well developed and spread root system increases the shearing resistance of the slope material. The barren and sparsely vegetated areas show faster erosion and greater instability. Based on the vegetation cover and its intensity, therefore, ratings for this parameter have been awarded. (Review of literature shows that extra cohesion due to root reinforcement is seldom more than 5 T/m^2). Thus, continuous vegetation and grass cover on entire hill slope is not fully responsible in landslide control because of root reinforcement but drastic decrease in the infiltration rate of rain water through thin humus layer on account of grass cover is more beneficial.

It may be noted that, in case of thickly populated areas, smaller facets of rock slopes may be taken into consideration.

Ground water conditions

Since the ground water in hilly terrain is generally channelised along structural discontinuities of rocks, it does not have uniform flow pattern. The observational evaluation of the ground water on hill slopes is not possible over large areas. Therefore, for quick appraisal, surface indications of water such as damp, wet, dripping and flowing are used for rating purposes. It is suggested that studies should be carried out soon after the monsoon season.

Other factors

A 100m to 200m wide strip on either side of major faults and thrusts and intra-thrust zones may be awarded an extra rating of 1.0 to consider higher landslide susceptibility depending upon intensity of fracturing.

18.2.2 Landslide Hazard Zonation

Ratings of all the parameters are added to obtain total estimated hazard rating (TEHR). Various zones of landslide hazard have subsequently been classified on the basis of TEHR as given in Table 18.3.

TABLE 18.3
CLASSIFICATION OF LANDSLIDE HAZARD ZONATION LHZ (GUPTA AND ANBALAGAN, 1995)

| Zone | Value of TEHR | Description of LHZ | Practical Significance |
|------|---------------|------------------------|---|
| I | < 3.5 | Very Low Hazard (VLH) | Safe for development schemes |
| II | 3.5-5.0 | Low Hazard (LH) | |
| III | 5.1-6.0 | Moderate Hazard (MH) | Local vulnerable zones of instabilities |
| IV | 6.1 - 7.5 | High Hazard (HH) | Unsafe for development schemes |
| V | > 7.5 | Very High Hazard (VHH) | |

18.2.3 Presentation of LHZ Maps

The results should be presented in the form of maps. The terrain evaluation maps are prepared in the first stage showing the nature of facet-wise distribution of parameters. The terrain evaluation maps are superimposed and TEHR is estimated for individual facets. Subsequently, LHZ maps are prepared based on facet wise distribution of TEHR values. For this exercise two types of studies are performed - (i) Desk or laboratory study and (ii) Field study. The general procedures of LHZ mapping techniques have been outlined in the form of a flow chart (Figure 18.1).

A case history has been presented to clarify the LHZ methodology and to develop confidence among users.

18.3 A Case History (Gupta and Anbalagan, 1995)

The present investigation covers Tehri-Pratapnagar area falling between Latitude (30°22' 15"-30°30'5") and Longitude (78°25' - 78°30'), (Figure 18.2).

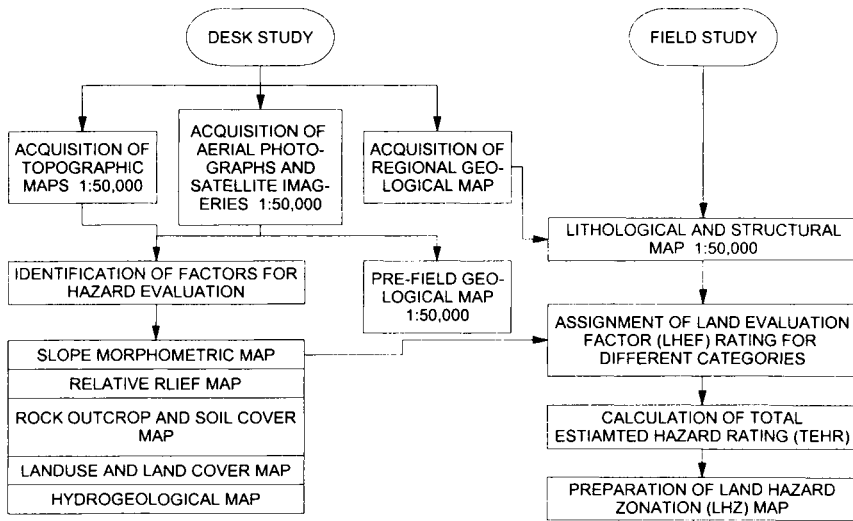

Figure 18.1: Procedure for macro-regional landslide hazard zonation (LHZ) mapping

18.3.1 Geology of the Area

The study area lies in Tehri District of Uttar Pradesh in India. The rock masses of the area belong to Damtha, Tejam and Jaunsar Groups. The stratigraphic sequence of the area and its vicinity is as follows (Valdiya, 1980).

| Nagthat - Berinag Formation | | |
|-----------------------------|---|---------------|
| Chandpur formation | - | Jaunsar group |
| Deoban formation | - | Tejam group |
| Rautgara formation | - | Damtha group |

The area has been mapped on 1:50,000 scale for studying the lithology and structure. The rocks exposed in the area include phyllites of Chandpur formation interbedded with sublitharenites of Rautgara formation, dolomitic limestone of Deoban formation and quartzites of Nagthat - Berinag formation. The phyllites are grey and olive green interbedded with metasiltstones and quartzitic phyllites. The Rautgara formation comprises purple, pink and white coloured, medium grained quartzites interbedded with medium grained grey and dark green sublitharenites and slates as well as metavolcanics. The Deoban formation consists of dense, fine grained dolomites of white and light pink colours with minor phyllitic

intercalations. They occupy topographically higher ridges. The Nagthat-Berinag formation includes purple, white and green coloured quartzites interbedded with greenish and grey slates as well as grey phyllites.

The Chandpur Formation is delimited towards north by a well defined thrust called North Almora thrust trending roughly northwest- southeast and dipping southwest. Moreover the Deoban and the Nagthat - Berinag Formations have a thrust contact, the thrust trending parallel to North Almora thrust and dipping northeast. The thrust is called Pratapnagar thrust. The rocks are badly crushed in the thrust zones.

18.3.2 Landslide Hazard Zonation Mapping

The LHZ map of this area has been prepared on 1:50,000 scale using LHEF rating scheme for which a facet map of the area has been prepared (Figure 18.3). A facet is a part of hill slope which has more or less similar characters of slope, showing consistent slope direction and inclination. The thematic maps of the area, namely lithological map (Figure 18.4), structural map (Figure 18.5), slope morphometry map (Figure 18.6), land use and land cover map (Figure 18.7), relative relief map (Figure 18.8), ground water condition map (Figure 18.9) have been prepared using the detailed LHEF rating scheme (Table 18.2).

18.3.3 Lithology (Figure 18.4)

Lithology is one of the major causative factors for slope instability. The major rock types observed in the area include phyllites, quartzites and dolomitic limestones. In addition, fluvial terrace materials are present in abundance to the right of river Bhagirathi all along its course.

Phyllites are exposed on either bank close to Bhagirathi river. Though older terrace materials are present at lower levels, thick eluvial and colluvial soil cover are present at places in the upper levels on the right bank. On the left bank, the phyllites are generally weathered close to the surface and support thin soil cover. At places, the thickness of soil cover is increasing up to 5m.

The North Almora thrust separates the Chandpur phyllites on the South from the quartzites of the Rautgara formation. The Rautgara quartzites interbedded with minor slates and metavolcanics are pink, purple and white coloured, well jointed and medium grained. The rocks and soil types in the area have the following distribution : phyllites - 44.17%, quartzites - 27.41%, marl/limestones- 12.48%, metabasics 0.25%, river terrace material 6.11%, phyllites with thin eluvial soil cover 6.16% and quartzites with thin soil cover 3.41% of the study area.

18.3.4 Structure (Figure 18.5)

Major structural features seen in the area are North Almora thrust and Pratapnagar thrust which form part of the Berinag thrust. The structures used for land slide hazard zonation mapping include beddings, joints and foliations. The dispositions of the structures have been plotted in a stereonet for individual facets. The inter-relation of the structural discontinuity with slope is studied carefully to award ratings.

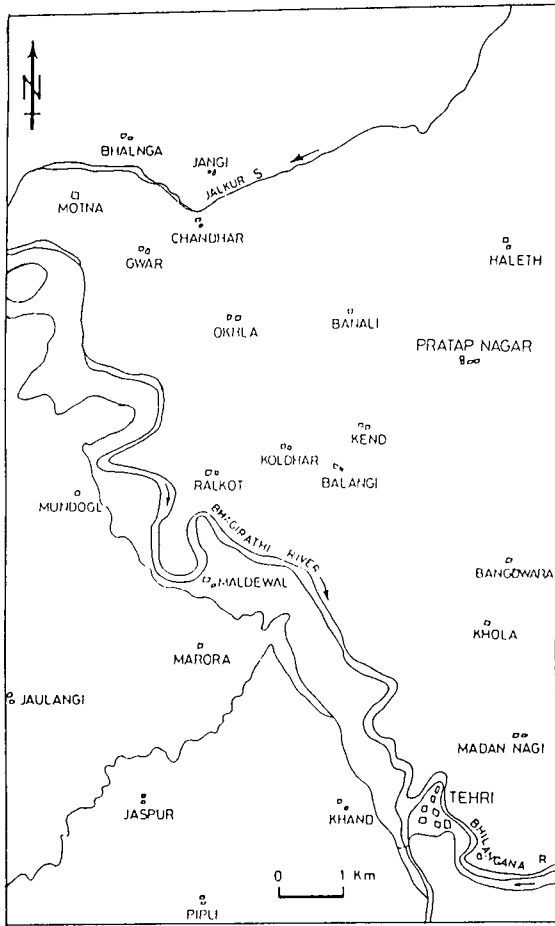

Figure 18.2: Location map of the study area

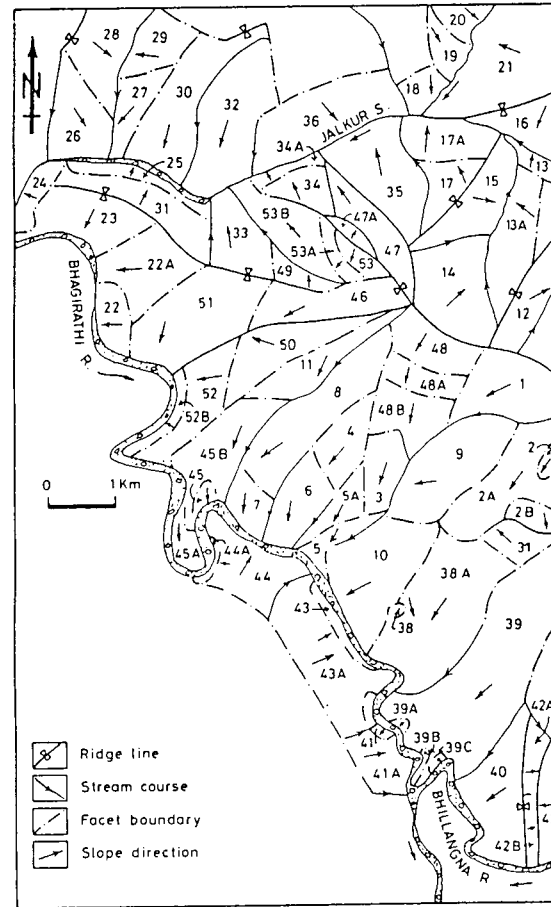

Figure 18.3: Facet map of the study area

Landslide hazard zonation

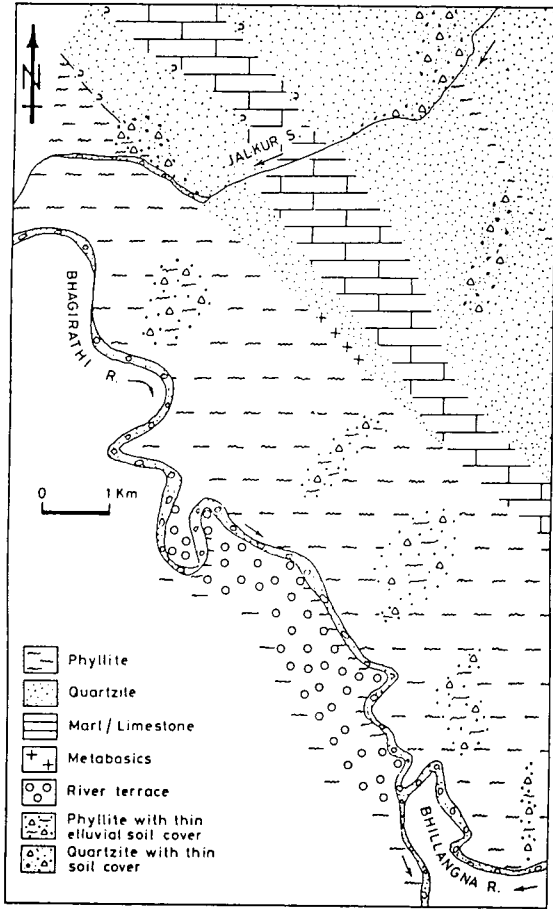

Figure 18.4: Lithological map

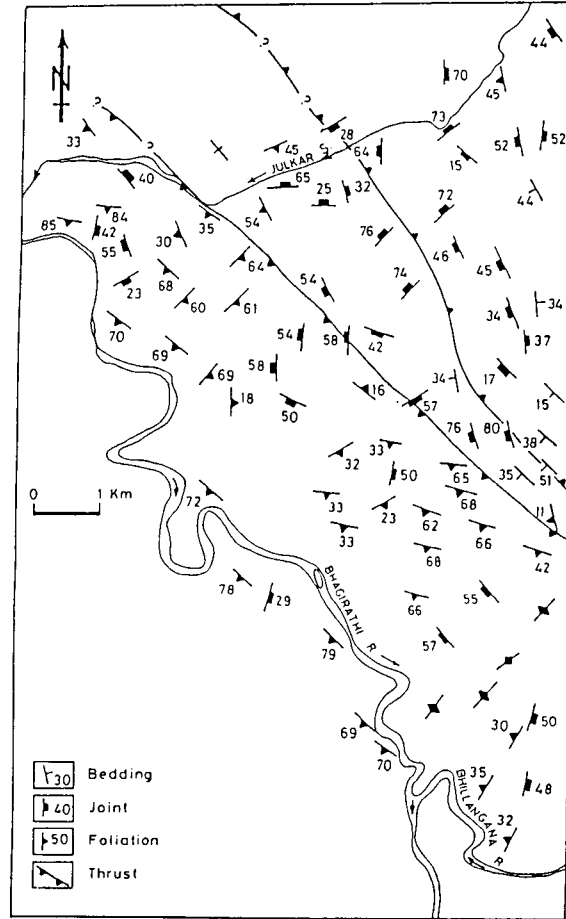

Figure 18.5: Structural map

18.3.5 Slope Morphometry (Figure 18.6)

A slope morphometry map represents the zones of different slopes, which have specific range of inclination. The area of study has a good distribution of slope categories. The area to the west of Bhagirathi river, mainly occupied by terrace deposits, falls in the category of very gentle slope. Gentle slopes are mainly confined to the agricultural fields. It has a good distribution throughout the area of study. Moderately steep slopes mainly occur in the central and eastern part of the area. Steep slopes mainly occur in the central and the eastern parts of the area. Very steep slopes occur in the northern part of the study area adjoining the Jalkur stream.

In fact, Jalkur stream flows through a tight, narrow, V-shaped gorge in this reach. Very steep slopes/escarpments occur in small patches, mainly close to the water courses possibly because of toe erosion. The area has the following distribution - 6.14%, 31.92%, 42.32%, 11.37% and 8.27% of very gentle slope, gentle slope, moderately steep slope, steep slope and very steep slope/escarpment respectively.

18.3.6 Land Use & Land Cover (Figure 18.7)

Vegetation cover generally smoothens the action of climatic agents and protects the slope from weathering and erosion. The nature of land cover may indirectly indicate the stability of hill slopes. Agriculture lands/populated flat lands are extensively present in the central, southeastern, southern and parts of northeastern areas. Thickly vegetated forest areas are seen in Pratapnagar - Bangdwara area. Moderately vegetated areas are mainly present in small patches to the west of thickly vegetated areas. Sparsely vegetated and barren lands are mainly confined to quartzitic and dolomitic limestone terrains where steep to very steep slopes are present. These types of slopes are seen along the Bhagirathi valley adjoining the river courses generally on steep slopes. The five categories of land use and land cover namely agricultural lands/populated flat lands, thickly vegetated forest area, moderately vegetated area, sparsely vegetated area and barren land have the distribution of 65.44%, 5.94%, 1.73%, 3.78% and 23.10% respectively in the study area.

18.3.7 Relative Relief (Figure 18.8)

Relative relief is the maximum height between the ridge top and the valley floor within an individual facet. The three categories of relative relief, namely high relief, medium relief and low relief, occupy 75.53%, 15.96% and 8.74% of the study area respectively.

18.3.8 Ground Water Condition (Figure 18.9)

The surface manifestation of ground water, such as wet, damp and dry have been observed in the study area. The area dominantly shows dry condition in about 54.86% of the area, damp condition in about 40.96% of the area and 4.8% of the study area is covered by wet ground water condition. Dry condition is mainly observed in the northern part and well distributed in rest of the study area. Damp and wet conditions are present in a number of facets in the southern, eastern and central part of the study area.



Figure 18.6: Slope morphometry

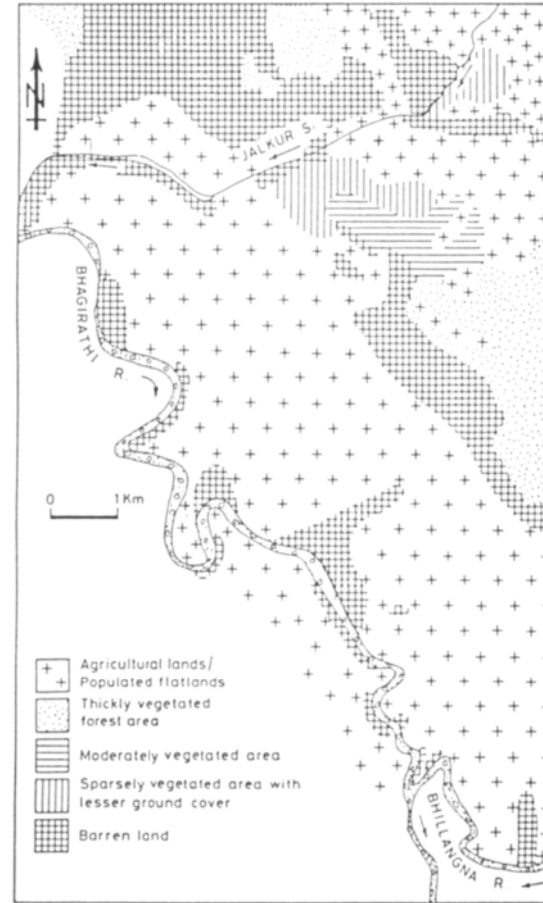

Figure 18.7: Land use and land cover map



Figure 18.8: Relative relief map

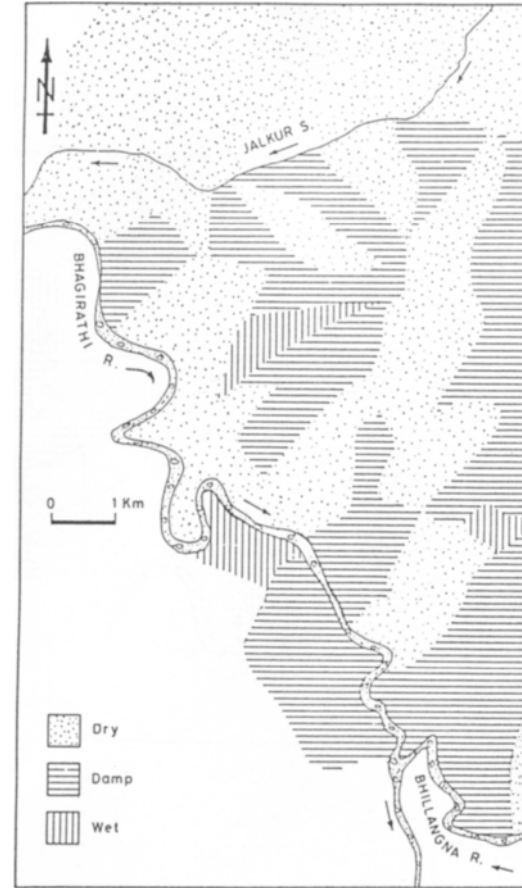

Figure 18.9: Groundwater condition map

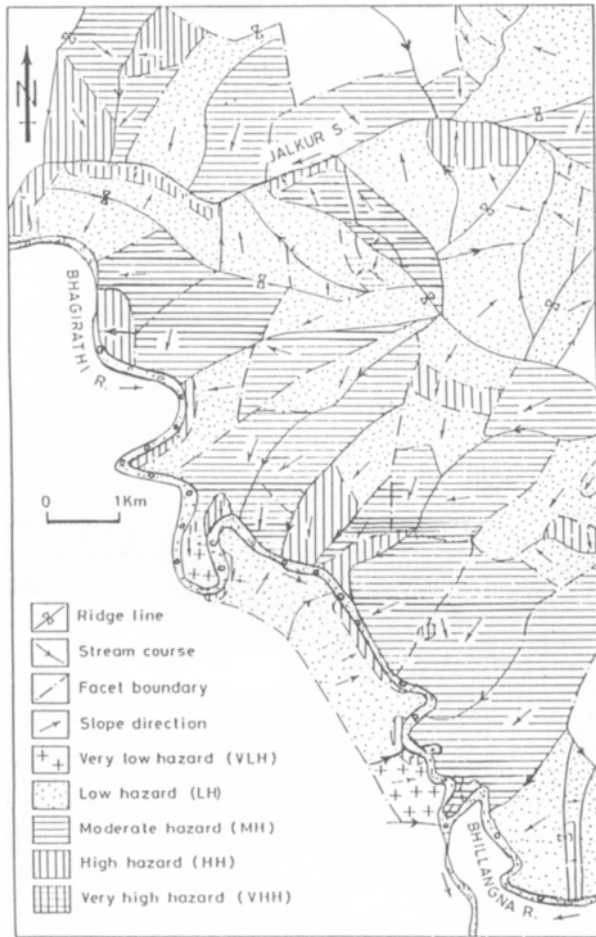

Figure 18.10: Landslide hazard zonation map (Gupta and Anbalagan, 1995)

18.3.9 Landslide Hazard Zonation (Figure 18.10)

The sum of all causative factors within an individual facet gives the total estimated hazard rating (TEHR) for a facet. The TEHR indicates the net probability of instability within an individual facet. Based on the TEHR value, facets are divided into different categories of hazard zones (Anbalagan, 1992).

The five categories of hazards, namely, very low hazard (VLH), low hazard (LH), moderate hazard (MH), high hazard (HH) and very high hazard (VHH) are found to be present in the study area. The areas showing VLH and LH constitute about 2.33% and 43.27% of the study area respectively. They are well distributed within the area. MH zones are mostly present in the immediate vicinities to the east of the Bhagirathi river. HH and VHH zones occur as small patches, mostly close to be the water courses. They represent areas of greater instability where detailed investigations should be carried out.

Some difficulty was experienced in zonation at the boundary lines. The visual inspection matched with Figure 18.10 for more than 85 percent area. As such, Anbalagan's technique may be adopted in all mountainous terrains with minor adjustments in his ratings. For rocky hill areas, SMR should be preferred.

18.4 Proposition for Tea Gardens

Tea gardens are recommended in medium and high hazard zones because of suitable soil and climatic conditions in this area. The tea gardens will reduce infiltration of rain water into the debris significantly and thereby stabilize landslide prone areas. Tea gardens will also provide job opportunities to local people and remove their poverty.

References

- Anbalagan, R. (1992). Terrain Evaluation and Landslide Hazard Zonation for Environmental Regeneration and Land Use Planning in Mountainous Terrain, *Int. Sym. on Landslides*, Christ church, New Zealand, pp. 861-868.
- Anbalagan, R. (1992). Landslide Hazard Evaluation and Zonation Mapping in Mountainous Terrain, *Engineering Geology*, Elsevier Science, **32**, pp. 269-277.
- Gupta, P. and Anbalagan, R. (1995). Landslide Hazard Zonation, Mapping of Tehri-Pratapnagar Area, Garhwal Himalayas, *J. Rock Mech. and Tunnelling Technology*, India, **Vol. 1, No. 1**, pp. 41-58,
- Valdiya, K. S. (1980). *Geology of Kumaon Lesser Himalaya*, Wadia Institute of Himalayan Geology, Dehradun, India, p. 291.

CHAPTER - 19

ALLOWABLE BEARING PRESSURE FOR BUILDING FOUNDATIONS

19.1 Introduction

Foundation on weak and highly undulating rock surfaces may pose serious problems. Rocks can be more heterogeneous than soil. The problem of differential settlement may therefore be serious in heterogeneous sub-surface rocks. The design of a foundation depends upon the subsurface strata and its bearing capacity. Where the foundation rests on rocks, the bearing pressure can be obtained from the available classification tables as described in this chapter. If a site is covered partly by rocks and partly by talus deposits or soil, care should be taken to account for the heterogeneity in deformability of soil and rocks. In such a case, it is generally suggested that plate load tests be conducted on talus or soil and bearing pressure be recommended considering 12mm settlement criterion, as is for rock masses.

19.2 Classification for Net Safe Bearing Pressure

Pressure acting on a rock bed due to building foundation should not be more than the safe bearing capacity of rock foundation system taking into account the effect of eccentricity. The effect of interference of different foundations should also be taken into account.

Universally applicable values of safe bearing pressure for rocks cannot be given at present. Many factors influence the safe bearing pressure which is frequently controlled by settlement criterion. Nevertheless, it is often useful to estimate the safe bearing pressure for preliminary design on the basis of the classification approach, although such values should be checked or treated with caution for final design.

Orientation of joints plays a dominant role in stress distribution below strip footings due to low shear modulus as shown in Figure 19.1 (Singh, 1973). Bearing capacity of rocks will be drastically low for near vertical joints with strike parallel to the footing length as pressure bulb extends deep into the strata. Shear zones and clay seams, if present below foundation level, need to be treated to improve bearing capacity and reduce differential settlement as discussed in Chapter 2.

A rock mass classification for assessing net safe bearing pressure is presented in Table 19.1 (Peck, Hansen and Thorburn, 1974).

The net safe bearing pressure and the allowable bearing pressure are the two terms which may be used in the same sense. But, the net safe bearing pressure here means the ultimate safe bearing pressure, whereas the allowable bearing pressure means the bearing pressure being

considered for the designs, i.e., allowable bearing pressure after taking into account the factor of safety.

19.3 Allowable Bearing Pressure

19.3.1 Using Rock Mass Rating RMR

Bieniawski's rock mass rating (Chapter 6) may also be used to obtain net allowable bearing pressure as per Table 19.2 (Singh, 1991 & Mehrotra, 1992). The guideline given in the Table

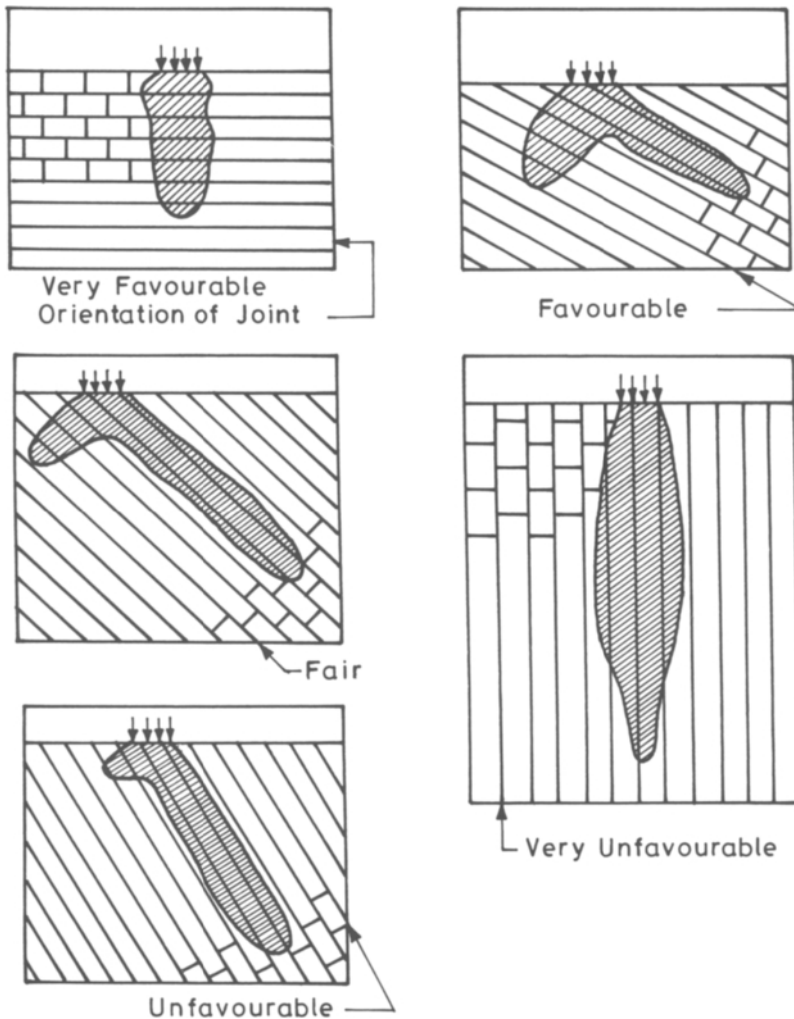

Figure 19.1: Theoretical pressure bulbs (10% intensity) below strip load on a medium of rock mass having low shear modulus (IS Code & Singh, 1973)

19.2 has been developed on the basis of plate load tests at about 60 sites and calculating the allowable bearing pressure for 6m wide raft foundation with settlement of 12mm. Figure 19.2 shows the observed trend between allowable bearing pressure and RMR (Mehrotra, 1992) which is similar to the curve from plate tests data of University of Roorkee (Singh, 1991).

TABLE 19.1
NET SAFE BEARING PRESSURE q_{ns} FOR VARIOUS ROCK TYPES (IN PECK ET AL., 1974)

| S. No. | Rock Type / Material | Safe Bearing Pressure q_{ns} (t/m^2) |
|--------|---|--|
| 1. | Massive crystalline bedrock including granite, diorite, gneiss, trap rock, hard limestone, and dolomite | 1000 |
| 2. | Foliated rocks such as schist or slate in sound condition | 400 |
| 3. | Bedded limestone in sound condition | 400 |
| 4. | Sedimentary rock, including hard shales and sandstones | 250 |
| 5. | Soft or broken bed rock (excluding shale) and soft limestone | 100 |
| 6. | Soft shales | 30 |

TABLE 19.2
NET ALLOWABLE BEARING PRESSURE q_a BASED ON RMR (MEHROTRA, 1992)

| Class No. | I | II | III | IV | V |
|---------------------|-----------|---------|---------|--------|-----------|
| Description of Rock | Very good | Good | Fair | Poor | Very poor |
| RMR | 100-81 | 80-61 | 60-41 | 40-21 | 20-0 |
| q_a (t/m^2) | 600-440 | 440-280 | 280-135 | 135-45 | 45-30 |

- Note:* 1. The RMR for Table 19.2 should be obtained below the foundation at depth equal to the width of the foundation, provided RMR does not change with depth. If the upper part of the rock, within a depth of about one fourth of foundation width, is of lower quality the value of this part should be used or the inferior rock should be replaced with concrete. Since the values in Table 19.2 are based on limiting the settlement, they should not be increased if the foundation is embedded into rock
2. During earthquake loading, the above values of allowable bearing pressure may be increased by 50 percent in view of rheological behaviour of rock masses.

19.3.2 Classification for Bearing Pressure

Another classification of rock masses for allowable bearing pressure is given in Table 19.3.

Allowable bearing pressure for building foundations

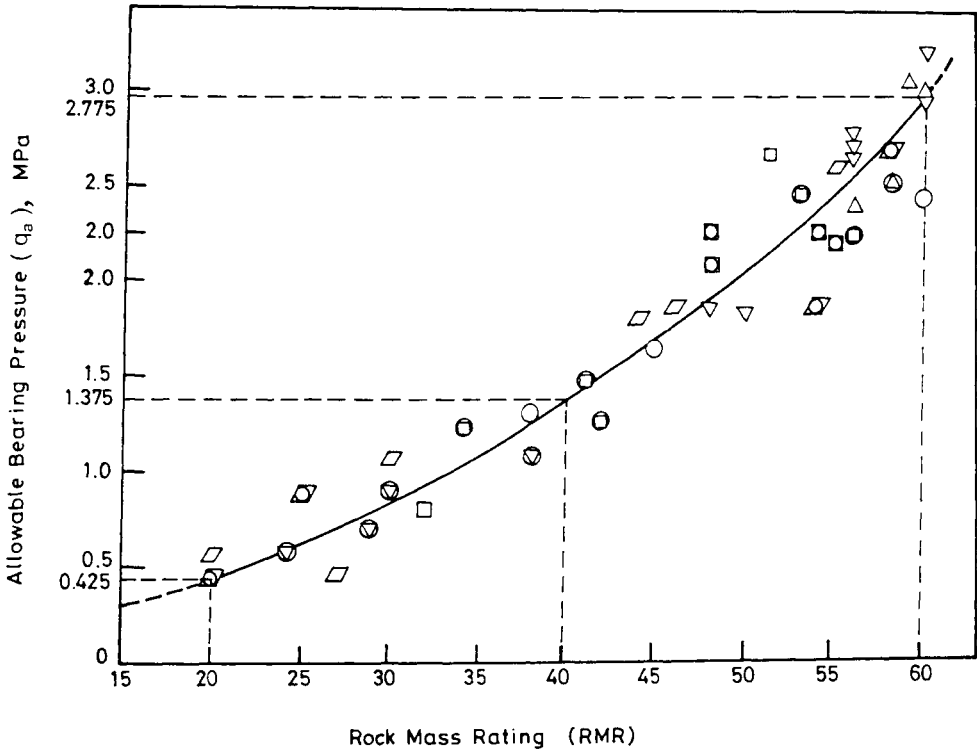

Figure 19.2: Allowable bearing pressure on the basis of rock mass rating and natural moisture content (nmc = 0.60 -6.50%) (Mehrotra, 1993)

There is also a correlation between RQD and allowable bearing pressure, but this correlation is conservative compared to the values in Table 19.3.

Canadian practice for socketed piles and shallow foundations (Gill, 1980) gives the following simple formula for safe bearing pressure.

$$q_a = q_c \cdot N_j \cdot N_d \tag{19.1}$$

where,

- q_a = allowable safe bearing pressure,
- q_c = average laboratory uniaxial compressive strength,
- N_j = empirical coefficient depending on the spacing of discontinuities (see Table 19.4)
- =
$$\frac{3 + (s/B)}{10 \cdot \sqrt{1 + (300 \cdot \delta / s)}} \tag{19.2}$$

Rock Mass Classification: A Practical Approach in Civil Engineering

$$\begin{aligned}
 s &= \text{spacing of joints in cm,} \\
 B &= \text{footing width in cm,} \\
 \delta &= \text{opening of joints in cm,} \\
 N_d &= 0.8 + 0.2 h/D < 2, \\
 &\geq 1.0 \\
 &= 1.0 \text{ for shallow foundations of buildings,} \\
 h &= \text{depth of socket in rock, and} \\
 D &= \text{diameter of socket.}
 \end{aligned}
 \tag{19.3}$$

TABLE 19.3
ALLOWABLE PRESSURE q_a OF VARIOUS ROCK TYPES UNDER DIFFERENT WEATHERING
CONDITIONS (KRAHENBUHL AND WAGNER, 1983)

| Rock Type | Highly Weathered Structure Unfavourable for Stability* | Fairly Weathered Structure Favourable for Stability | Highly Weathered Structure Favourable for Stability | Fairly Weathered Structure Favourable for Stability | Unweathered Rock Structure Unfavourable for Stability | Unweathered Rock Structure Favourable for Stability |
|--|--|---|---|---|---|---|
| Marls, marls interbedded with sandstone | 15 | 30 | 35 | 50 | 60 | 110 |
| Calc-schist, Calc-schist interbedded with quartzites | 15 | 30 | 45 | 65 | 100 | 200 |
| Slates, phyllites, schists interbedded with hard sandstones and or quartzite or gneiss | 20 | 35 | 60 | 75 | 90 | 130 |
| Limestone, dolomites and marbles | 50 | 80 | 90 | 130 | 150 | 200 |
| Sandstone | 40 to 60 (massive) | 90 | 120 | 150 | 170 | 220 |
| Calcareous conglomerates (massive) | 60 | 100 | 120 | 200 | 200 | 330 |
| Quartzite (massive) | 50 to 70 | 150 | 120 | 180 | 200 | 330 |
| Gneiss (massive) | 30 to 60 | 150 | 120 | 180 | 200 | 330 |
| Granite and Leucocratic plutonic rocks | 20 | 250 | > 330 | -- | -- | -- |

* This column indicates sites with highly weathered rock and unfavourable geological structures, subjected to instability

TABLE 19.4
VALUE OF N_j

| Spacing of Discontinuities, cm | N_j |
|--------------------------------|-------|
| 300 | 0.4 |
| 100 - 300 | 0.25 |
| 30 - 100 | 0.1 |

Equation 19.1 may also be applied to shallow foundations considering $N_d = 1$. It may be noted however that the above correlation does not account for orientation of joints.

The results of plate load tests show that the settlement consideration of 12 mm gives generally lower allowable bearing pressure than the strength consideration (Eqn. 19.1). It is safer, therefore, to use settlement considerations in heterogeneous rocks.

It is a debatable issue that what correction should be applied if a rock mass is submerged. It is suggested that the bearing pressure be reduced by 25-50 percent depending upon the clay content of the gouge and its thickness. Correction must also be applied if the dip of the joints is unfavourable, i.e., steeply inclined joints in flat ground and joints dipping towards valley in case of slopes.

It is, therefore, recommended that plate load tests should be conducted on poor rocks where allowable bearing pressure is likely to be less than 100 t/m^2 . It is a fact that a rock mass is more heterogeneous compared to soil. Therefore, a large number of observation pits should be made - say at a rate of at least 3 per important structure. The tests should be conducted in the pit representing the poorest rock qualities. Needless to mention that the allowable bearing pressure is frequently found to decrease with the number of observation pits and tests.

19.4 Coefficient of Elastic Uniform Compression for Machine Foundations

The coefficient of uniform compression C_u is defined as the ratio between pressure and corresponding settlement of block foundation. Typical values of coefficient of elastic uniform compression C_u for machine foundations on a rock mass are listed in Table 19.5 (Ranjan et al., 1982). The coefficient of uniform shear is generally taken as $C_u / 2$. It may be noted that C_u is less than 10 kg/cm^3 in very poor rocks.

Elastic modulus of rock mass E_c (Eqn. 8.15 in Chapter 8, $\text{SRF} = 2.5$) may be used for calculating C_u . Cyclic plate load tests is more reliable for this purpose.

TABLE 19.5
COEFFICIENT OF ELASTIC UNIFORM COMPRESSION C_u FOR ROCK MASSES

| S. No. | Rock Type | Allowable Bearing Pressure (t/m^2) | C_u ($kg/cm^2/cm$) |
|--------|------------------------------|--|------------------------|
| 1. | Weathered granites | - | 17 |
| 2. | Massive limestones | 160 | 25 |
| 3. | Flaky limestones | 75 | 12 |
| 4. | Shaly limestones | 50 | 7 |
| 5. | Soft shales | 45 | 7 |
| 6. | Saturated soft shales | 33 | 1.5 |
| 7. | Saturated non-plastic shales | 27 | 2.6 |

References

Gill, S. A. (1980). Design and Construction of Rock Caissons, *Int. Conf. Structural Foundations on Rock*, Sydney, pp. 241- 252.

Krahenbuhl, J. K. and Wagner, A. (1983). Survey Design and Construction of Trail Suspension Bridges for Remote Area, **Vol. 8**, pp. 325.

Peck, R. B., Hausen, W. E. and Thornburn, T.H. (1974). *Foundation Engineering*, John Wiley, Second Edition, **Chapter 22**, p.512.

Ranjan, G., Agarwal, K. B., Singh, Bhawani and Saran, S. (1982). Testing of Rock Parameters in Foundation Design, *IVth Congress of International Association of Eng. Geology*, New Delhi, **Vol. III**, pp. 273-287.

Singh, Bhawani. (1973). Continuum Characterization of Jointed Rock Mass Part II - Significance of Low Shear Modulus, *Int. Jr. Rock Mech. and Min. Sci. & Geomech. Abstr.*, Pergamon, **Vol. 10**, pp. 337-349.

Singh, Bhawani. (1991). Application of Rock Classification Methods for Underground Construction in River Valley Projects, *Proc. Workshop on Rock Mech. Problems of Tunnels, Mine Roadways and Caverns*, Ooty, pp. IV-1 - IV-41.

IS:12070 (1987). Indian Standard Code of Practice for Design and Construction of Shallow Foundations on Rocks, Publication of *Bureau of Indian Standards*, New Delhi, India.

CHAPTER - 20

METHOD OF EXCAVATION

"Blasting for underground construction purposes is a cutting tool, not a bombing operation" - Svanholm et al. (1977)

20.1 Excavation Techniques

Excavation of rock or soil is an important aspect of a civil engineering project. The excavation techniques or the methods of excavation in rocks differ those in soil. Similarly, these change with the purpose.

Broadly, methods of excavation can be classified according to the purpose of excavation, i.e., whether the excavation is for foundations, slopes or underground openings. Method of excavation in a broader sense can be divided into three types, viz,

- a. Digging,
- b. Ripping, and
- c. Blasting.

A classification was proposed by Franklin et al. (1972) to classify the method of excavation on the basis of the rock material strength (Figures 20.1a & 20.1b). Figure 20.1a shows a plot between the point strength of rocks and the fracture spacing, whereas Figure 20.1b is drawn between point strength and rock quality. Using these figures, one can select a method of excavation for a particular rock, e.g., a rock of medium strength and medium fracture spacing is classified as medium rock (Figure 20.1a) and therefore should be excavated by ripping (Figure 20.1b). There is too much confusion on soil-rock boundary line. ISO defines a geological material having UCS less than 0.6 MPa as soil.

This classification would be useful in estimating the cost of excavation which should be paid to a contractor who may not prefer to change the method of excavation according to rock condition.

20.2 Assessing the Rippability

Assessing the rippability is also an important aspect of excavation. Even stronger rocks such as limestones and sandstones, when closely jointed or bedded, are removed by heavy rippers, at least down to the limit of weathering and surficial stress relief.

Sedimentary rocks are usually easily ripped. Rippability of metamorphic rocks, such as gneisses, quartzites, schists and slates depends on their degree of lamination and mica content. Igneous rocks are often not possible to rip, unless very thinly laminated as in some volcanic lava flows.

Ripping is comparatively easier in open excavations. In confined areas or in a narrow trench, however, the same rock often requires blasting due to confinement effect and difficulties in using a ripper in confined space.

20.3 Rock Mass Classification According to Ease of Ripping

Based on the combined effects of the following five parameters, a rippability index classification (RIC) has been developed by Singh et al. (1987) as presented in Table 20.1.

- a. Uniaxial tensile strength of rock material, determined by Brazilian Disc test or derived from point load index values,

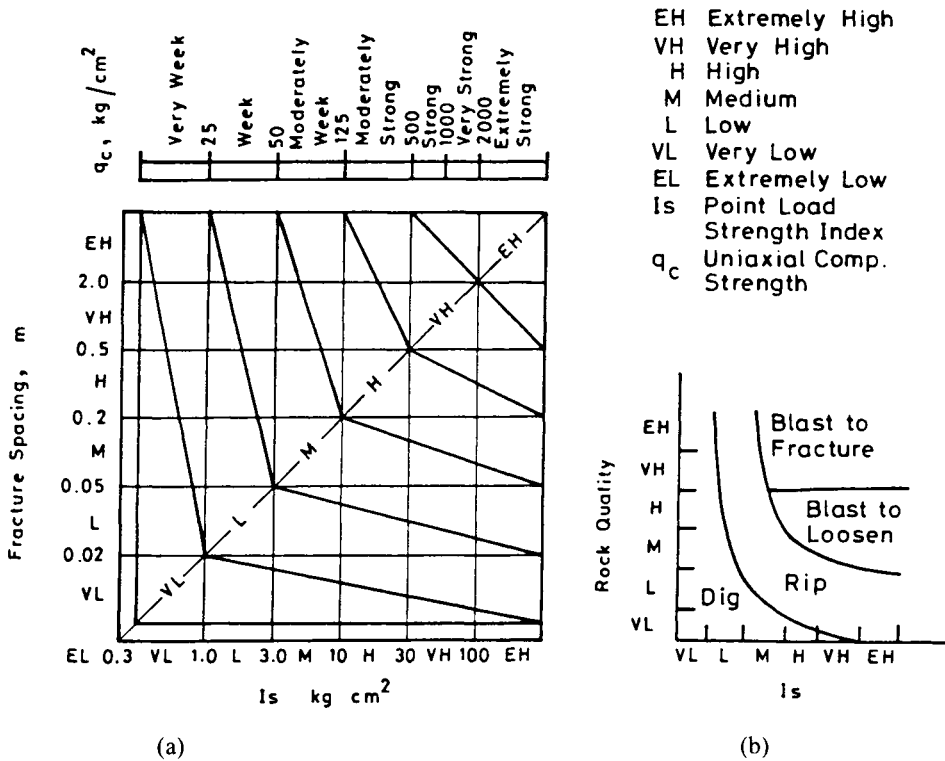

Figure 20.1: Rock mass classification for excavation (Franklin et al., 1971)

Method of excavation

- b. Degree of weathering, determined by visual observations.
- c. Seismic wave velocity, determined by surface or cross-hole seismic surveys; the velocity may be as high as 6 km/s for a strong, dense and unweathered rock mass or as low as 300 m/s for a loose unsaturated soil,
- d. Abrasiveness of rock material, the abrasiveness index classification based on the Cerchar index value and the examination of physical and mineralogical properties of rock is given by Singh et al. (1986), and
- e. Spacing of discontinuities, measured by the scanline survey.

The rippability index classification (RIC) is the result of broad examination of existing rippability classifications and experience gained on a number of open-cast sites in UK and Turkey (Singh et al., 1987). The rippability index is the algebraic sum of the values of the weighted parameters given in Table 20.1. The index, subsequently, has been used to indicate the quality of rock mass with respect to its rippability.

TABLE 20.1
CLASSIFICATION OF ROCK MASS ACCORDING TO RIPPABILITY INDEX (SINGH ET AL., 1987)

| Parameter | Class 1 | Class 2 | Class 3 | Class 4 | Class 5 |
|---------------------------------|----------------|----------------|----------------|-----------------|----------------|
| Uniaxial Tensile Strength (MPa) | < 2 | 2 - 6 | 6 - 10 | 10 - 15 | >15 |
| Rating | 0 - 3 | 3 - 7 | 7 - 11 | 11 - 14 | 14 - 17 |
| Weathering | completely | highly | moderately | slightly | Unweathered |
| Rating | 0 - 2 | 2 - 6 | 6 - 10 | 10 - 14 | 14 - 18 |
| Sound Vel. (m/s) | 400 - 1100 | 1100-1600 | 1600-1900 | 1900-2500 | > 2500 |
| Rating | 0 - 6 | 6 - 10 | 10 - 14 | 14 - 18 | 18 - 25 |
| Abrasiveness | very low | low | moderately | highly | extremely |
| Rating | 0 - 5 | 5 - 9 | 9 - 13 | 13 - 18 | 18 - 22 |
| Discontinuity Spacing (m) | < 0.06 | 0.06 - 0.3 | 0.3 - 1 | 1 - 2 | > 2 |
| Rating | 0 - 7 | 7 - 15 | 15 - 22 | 22 - 28 | 28 - 33 |
| Total rating | < 30 | 30 - 50 | 50 - 70 | 70 - 90 | > 90 |
| Ripping Assessment | easy | moderate | difficult | marginal | blast |
| Recommended Dozer | light duty | medium duty | heavy duty | very heavy duty | |

Abdullatif and Cruden (1983) compared three other systems - the Franklin (1974), the Norwegian Q and South African RMR systems, all based on block size and rock strength. They conducted excavation trials with rock mass quality measurements in limestone, sandstone, shale and some igneous rocks at 23 sites in U.K. and found that the RMR system (Chapter 6) gave the best predictions. They offered following guidelines for selecting method of excavation (Table 20.2).

TABLE 20.2
SELECTION OF METHOD OF EXCAVATION BASED ON RMR

| RMR Value | Excavation Method |
|-----------|-------------------|
| < 30 | Digging |
| 31 - 60 | Ripping |
| 61 - 100 | Blasting |

20.4 Empirical Methods in Blasting

The study of Ibarra at the Aguamilpa hydropower tunnels in Mexico presented by Franklin (1993) showed application of empirical methods for optimization of blast designs. Based on 92 measured tunnel sections, overbreak was shown to correlate with rock mass quality Q . As expected, overbreaks were found to be inversely proportional to the rock mass quality (Figure 20.2a).

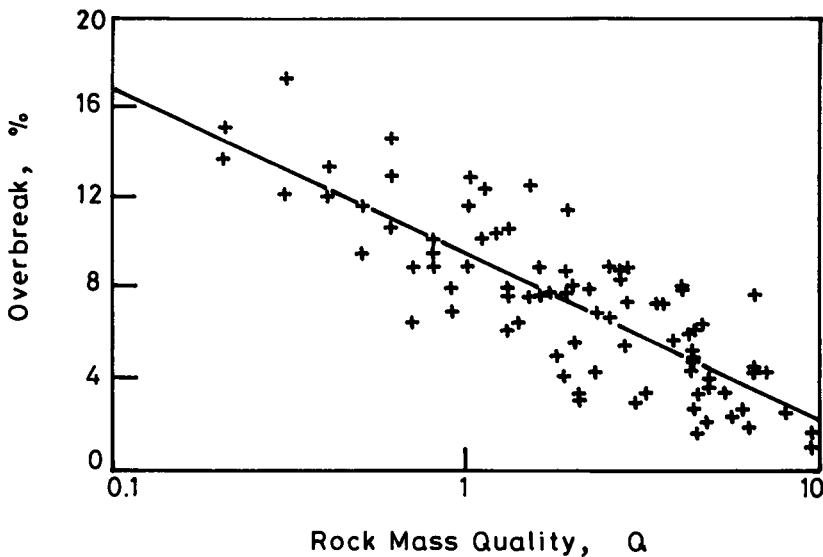

Figure 20.2a : Overbreak as a function of rock mass quality Q (Franklin, 1993)

In addition, Ibarra found that for any given rock quality Q , the overbreak increases in proportion to the perimeter powder factor, defined as the weight of explosives in the perimeter blastholes divided by the volume of rock removed (perimeter length x drillhole depth x burden). Using the results of Figure 20.2b, the optimum perimeter powder factor can be determined for the given quality of a rock mass.

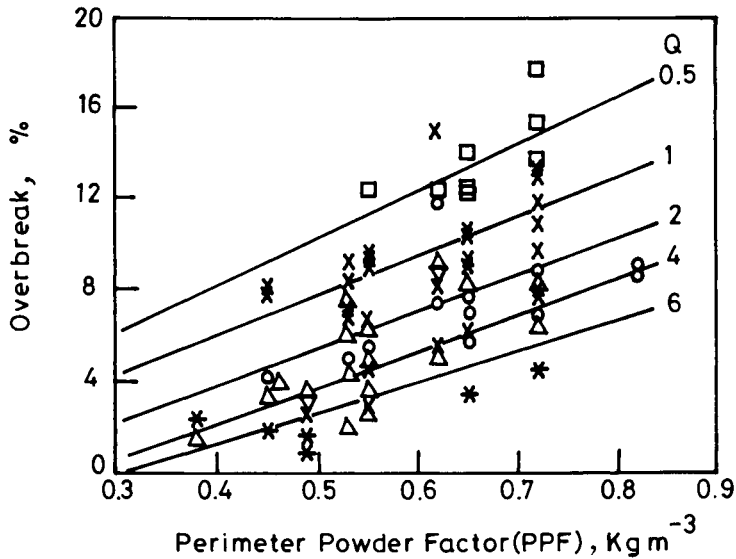

Figure 20.2b : Overbreak as a function of perimeter powder factor (Franklin, 1993)

Chakraborty, Jethwa and Dhar (1997) have found the following trend between average powder factor p_f (weight of explosive divided by volume of broken rock) and weighted average of rock mass quality Q in tunnels within massive Basalts;

$$p_f = 1.02 + 0.0005 Q \text{ kg/m}^3 \quad (20.1)$$

The coefficient of correlation is 0.82. Chakraborty et al. (1997) have also inferred that p_f increases directly with UCS (q_c). They have used these correlations to suggest tunnel rock blasting index (TBI) for reliable prediction of powder factor. Further research may give specific classification for rock blasting in tunnels.

References

- Abdullatif, O. M. and Cruden, D. M. (1983). The Relationship between Rock Mass Quality and Ease of Excavation, *Bull. Int. Assoc. Eng. Geology*, Vol. 28, pp. 183-187.
- Chakraborty, A. K., Jethwa, J. L. and Dhar, B. B. (1997). Predicting Powder Factor in Mixed - Face Condition: Development of a Correlation Based on Investigations in a Tunnel through Basaltic Flows, *Engineering Geology*, Elsevier Science, 47, pp. 31-41.
- Franklin, J. A. (1974). Rock Quality in Relation to the Quarrying and Performance of Rock Construction Materials, *Proc. 2nd Int. Cong., Int. Assoc. Eng. Geol.* (Sao Paulo Brazil, 1974), Paper IV - PC-2, pp.11.

Rock Mass Classification: A Practical Approach in Civil Engineering

- Franklin, J. A. (1993). Empirical Design and Rock Mass Characterisation, *Comprehensive Rock Engineering*, Pergamon, Edited by Hudson, J. A., **Vol. 2**, pp. 795-806.
- Franklin, J. A., Broch, E. and Walton, G. (1972). Logging the Mechanical Character of Rock, *Trans. Inst. Mining Metallurgy*, **A80**, A1-A9 and Discussion A81, A34, A51.
- ISO Standard on Geotechniques in Civil Engineering - Identification and Description of Rock (Draft), *ISO/DIS 14689*, 1997, p.18.
- Kirsten, H. A. D. (1982). A Classification System for Excavation in Natural Material, *Siviele Ingenieur in Suid Afrika*, pp. 293-308.
- Singh, R.N., Denby, B. and Egretli, I. (1987). Development of a New Rippability Index for Coal Measures Excavations, *Proc. 28th US Sym. on Rock Mech.*, Tucson, pp. 935-943. Reprinted from: Farmer, Ian W., J.J.K. daeman, C.S. Desai, C.E. Glass & S.P. Neuman (eds), *Rock Mechanics: Proceedings of the 28th US Symposium*, Tucson, Arizona, 29 June - 1 July 1987. 1987. 1264 pp., Hfl.260/US\$130.00/£87. A.A. Balkema, P.O. Box 1675, Rotterdam, Netherlands.
- Singh, R. N., Denby, B., Egretli, I., and Pathan, A. G. (1986). Assessment of Ground Rippability in Open Cast Mining Operations, Nottingham University, *Mining Department Magazine*, 38: 21-34.
- Smith, H. J., Hardy, J. S. (1986). Estimating Rippability by Rock Mass Classification, *Proc. 27th U.S. Rock Mech. Sym.*, University of Albana, pp. 443-448.
- Svanholm B. O., Persson P. A. and Larsson B. (1977). Smooth Blasting for Reliable Underground Openings, *Proc. 1st Int. Sym. on Storage in Excavated Rock Caverns*, Stockholm, **Vol.3**, pp.37 - 43.

CHAPTER - 21

ROCK DRILLABILITY

21.1 Drillability and Affecting Parameters

The Rock drillability or speed of drilling for blasthole and rock bolting needs to be estimated to assess the cycle time of tunnelling for given set up of tunnelling machines. Construction time for pack grouting and consolidation grouting also depends on the same.

The term Rock drillability means the ease of drilling a hole in the rock mass. Studies have shown that the drillability of rock and thereby the penetration rate of a drill are affected by -

- (i) rock hardness,
- (ii) rock texture and density,
- (iii) rock fracture pattern and
- (iv) general structure of the formation/rock mass.

The above parameters do not account for the drilling equipment characteristics. Each of the above properties affecting the drillability are considered separately. An experienced driller can tell how a rock will drill. The important thing to know is how fast it will drill. Considering these four properties, rock drillability may be classed in to five conditions: fast, fast average, average, slow average and slow. Various properties can be determined as follows.

21.1.1 Hardness

Hardness of a mineral may be obtained by Mohs Scale of Hardness shown in Table 21.1. The number against each mineral in Table 21.1 indicates the hardness of the representative mineral. A higher number means that it is harder than the next lower number. Minerals with a higher number can scratch any one with the same or the lower number. Rocks may contain more than one mineral, so tests should be made at several places on a piece of rock in order to determine the average hardness. Mohs hardness kits for testing minerals can be used in the field also.

TABLE 21.1
MOHS HARDNESS SCALE (NAST, 1955)

| | | | |
|----|----------|-----|----------|
| 1. | Talc | 6. | Feldspar |
| 2. | Gypsum | 7. | Quartz |
| 3. | Calcite | 8. | Topaz |
| 4. | Fluorite | 9. | Corundum |
| 5. | Apatite | 10. | Diamond |

21.1.2 Texture

Texture may be determined by visual inspection of the grain structure of the rock and then classified for the drilling condition as shown in Table 21.2 (Wilbur, 1982).

TABLE 21.2
TEXTURE (WILBUR, 1982)

| Drilling Condition | Type of Rock and Texture |
|--------------------|--|
| Fast | Porous (cellular or filled with cavities) |
| Fast average | Fragmental (fragments, loose or semi-consolidated) |
| Average | Granitoid (grains large enough to be readily recognized - average grained granite) |
| Slow average | Porphyritic (large crystals in fine - grained granite) |
| Slow | Dense (grain structure too small to identify with naked eye) |

21.1.3 Fracture

Fracture in case of drillability refers to how a rock breaks apart when struck by a blow with a hammer. Five drilling conditions are correlated with type of rock and fracture pattern in Table 21.3.

TABLE 21.3
FRACTURE (WILBUR, 1982)

| Drilling Condition | Type of Rock and Fracture Pattern |
|--------------------|---|
| Fast | Crumbles into small pieces when struck lightly |
| Fast average | Brittle (rock breaks with ease when struck lightly) |
| Average | Sectile (when slices can be shaved or split off and crumbles when hammered) |
| Slow average | Tough (rock resists breaking when struck with heavy blow) |
| Slow | Mallable (rock that tends to latten under blow of hammer) |

21.1.4 Formation

Formation describes the condition of rock mass structure. Various formations facilitating the five drilling conditions are shown in Table 21.4. It can be seen that a high drilling rate is possible in massive rocks whereas slow drilling is obtained in blocky and seamy rock masses.

The rock chart in Figure 21.1 shows drilling characteristics for the five drilling conditions (Nast, 1955).













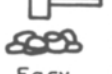

| Rock Characteristic | Classification of Drilling Conditions | | | | |
|---|--|--|--|--|---|
| | Fast | Fast Average | Average | Slow Average | Slow |
| Hardness The Scale Soft to Hard | 1-2 | 3-4 | 5-6 | 7 | 8-9 |
| Texture | Porous | Fragmental | Granitoid | Porphyritic | Dense |
| The Quality Poor to Good |  |  |  |  | |
| Fracture | Crumbly | Brittle | Sectile | Tough | Malleable |
| The Break  |  Crumbles |  Easy |  Splits |  Hard |  Flattens |
| Formation | Massive | Sheets | Laminated | Seamy | Blocky |
| The Lay  |  |  |  |  |  |

Figure 21.1: Rock drilling characteristics (Nast, 1955)

21.2 Classification for Drilling Condition

When the characteristics of a rock fall into different conditions, which is usually the case, it is necessary to compute final drilling conditions. This may be done by using the point system chart shown in Table 21.5. The chart may be used as explained below.

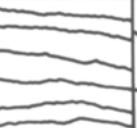
For obtaining the information on the drillability of a particular rock mass, the points for each characteristics are added to get total points (Table 21.5). In extreme cases of drilling conditions, a judgment should be made cautiously. If three characteristics are fast and one (say formation) is slow, the three fast ones would be revised to average, or to a total of 10 (3+3+3+1) points, correcting a fast condition to an average condition. On the other hand, if three characteristics are slow and one (again say formation) is fast, the fast one would be revised to an average, or the three slow ones would be revised to a slow-average.

TABLE 21.4
FORMATION (WILBUR, 1982)

| Drilling Condition | Type of Rock with Respect to Formation |
|--------------------|---|
| Fast | Massive (solid or dense practically no seams) |
| Fast average | Sheets (layers or beds 4 to 8 feet (1.2 to 2.4m) thick with thin horizontal seams) |
| Average | Laminated (thin layers 1 to 3 feet (0.3 to 0.9m) thick with horizontal seams with little or no earth) |
| Slow average | Seamy (many open seams in horizontal and vertical positions) |
| Slow | Blocky (wide open seams in all directions and filled with earth or shattered or fissured) |

TABLE 21.5
DRILLING CONDITION POINT SYSTEM CHART (NAST, 1955)

| Nature of Rock | Fast | Fast Average | Average | Slow Average | Slow |
|----------------|------|--------------|---------|--------------|------|
| Hardness | 8 | 4 | 3 | 2 | 1 |
| Texture | 8 | 4 | 3 | 2 | 1 |
| Fracture | 8 | 4 | 3 | 2 | 1 |
| Formation | 8 | 4 | 3 | 2 | 1 |
| Total | 32 | 16 | 12 | 8 | 4 |

Drillability, in other words, may be measured by the drilling speed (cm per minute) at which a drill bit penetrates in the rock mass. A drillability factor has been determined for all drilling conditions from performance study of rock drilling jobs both on field and in the laboratory (Table 21.6). The drillability factor of each condition has subsequently been correlated with the drilling speed (Table 21.6). Therefore, Table 21.6 can be used to know the drilling speed, once the drilling condition is known.

Rock drillability

TABLE 21.6
DRILLABILITY VERSUS DRILLING SPEED (NAST, 1955)

| Drilling Condition | Fast | Fast Average | Average | Slow Average | Slow |
|----------------------------|------|--------------|---------|--------------|------|
| Drillability Factor | 2.67 | 1.33 | 1.0 | 0.67 | 0.33 |
| Drilling Speed (cm/minute) | 50 | 25 | 18 | 12 | 6 |

TABLE 21.7
TYPICAL VALUES OF DIAMOND POINTER REBOUND FOR A FEW
ROCK TYPES (BATEMAN, 1967)

| Minerals | | Igneous Rocks | |
|-------------------|--------|-------------------|---------|
| Gypsum | 12 | Basalt | 90 |
| Calcite | 45 | Diorite | 90 |
| Feldspar | 90 | Rhyolite | 100 |
| Quartz | 115 | Granite | 100-110 |
| Sedimentary Rocks | | Metamorphic Rocks | |
| Shale | 30-50 | Marble | 40-50 |
| Limestone | 40-60 | Slate | 50-60 |
| Sandstone | 50-60 | Schist | 60-65 |
| Taconite | 90-115 | Quartzite | 100-115 |

21.3 Other Approaches

Scleroscope Hardness Reading as used by Joy Manufacturing Company in its laboratory, gives more definitive results in determining drillability of rocks (Bateman, 1967). In this method, a small diamond pointed hammer is dropped from a height of 25cm through a thin glass tube to strike rock samples and the height of rebound is measured. The harder the sample, the higher would be the rebound of diamond pointer hammer. The typical observations of rebound height for a few rock types are shown in Table 21.7. Soft rocks are crushed to powder by the hammer, while the hard rocks are partly shattered, with most of the energy being returned in the rebound. This action is analogous to the percussion drill and the information can provide useful information on the drillability of rock masses.

References

Bateman, W. M. (1967). *Rock Analysis*, Joy/Air Power, Joy Manufacturing Company, March-April in *Tunnel Engineering Handbook*, Ed. Bickel, Jon, O. and Kuesel, T. R.

Rock Mass Classification: A Practical Approach in Civil Engineering

- Bickel, Jon, O. and Kuesel, T. R. (1982). *Tunnel Engineering Handbook*, A Publication of Van Nostrand Reinhold Company, p.670.
- Nast, Paul. H. (1955). *Drillers Handbook on Rock*, Davey Compressor Company, Kent Ohio.
In *Tunnel Engineering Handbook*, Ed. Bickel, Jon, O. and Kuesel, T. R.
- Wilbur, Lyman, D. (1982). Rock Tunnels, **Chapter 7** in *Tunnel Engineering Handbook*, Edited by Bickel and Kuesel as referred above, pp. 123-207.

CHAPTER - 22

PERMEABILITY AND GROUTABILITY

22.1 Permeability

Permeability is defined as a property of porous material that permits passage or seepage of fluids, such as water and or gas, through its interconnecting voids.

The resistance to flow depends upon the type of the rock, the geometry of the voids in rock (size and shape of the voids) and the surface tension of water (temperature and viscosity effects). The coefficient of permeability, thus, is a function of rock type, pore size, entrapped air in the pores, rock temperature and viscosity of water.

Because of rock defects, viz., irregularity in the amount of fissures and voids and their distribution, permeability of rocks is non-linear and non-uniform. Non-uniform permeability in rocks may also be caused by contraction and expansion of rock fissures. Therefore, the concept of regular ground water table is not applicable in complex geological conditions.

22.2 Permeability of Various Rock Types

Anisotropic conditions in rocks do permit to establish a permeability chart as in the case of soils. However, Table 22.1 is given for guidance.

TABLE 22.1
APPROXIMATE COEFFICIENT OF PERMEABILITY OF ROCKS AT 15°C AND
POROSITY η (JUMIKIS, 1983)

| In-situ Rock | Coefficient of Permeability k, cm/sec | Porosity η |
|--------------------------|--|-----------------|
| <i>Igneous Rocks</i> | | |
| Basalt | 10^{-4} to 10^{-5} | 1 to 3 |
| Diabase | 10^{-5} to 10^{-7} | 0.1 to 0.5 |
| Gabbro | 10^{-5} to 10^{-7} | 0.1 to 0.5 |
| Granite | 10^{-3} to 10^{-5} | 1 to 4 |
| <i>Sedimentary Rocks</i> | | |
| Dolomite | $4.6 \cdot 10^{-9}$ to $1.2 \cdot 10^{-8}$ | -- |
| Limestone | 10^{-2} to 10^{-4} | 5 to 15 |
| Sandstone | 10^{-2} to 10^{-4} | 4 to 2 |
| Slate | 10^{-3} to 10^{-4} | 5 to 2 |

TABLE 22.1 (Continued)

| <i>Metamorphic Rocks</i> | | |
|--------------------------|----------------------------------|------------|
| Gneiss | 10^{-3} to 10^{-4} | -- |
| Marble | 10^{-4} to 10^{-5} | 2 to 4 |
| Quartzite | 10^{-5} to 10^{-7} | 0.2 to 0.6 |
| Schist | 10^{-4} to $3.0 \cdot 10^{-4}$ | -- |
| Slate | 10^{-4} to 10^{-7} | 0.1 to 1 |

Knill (1969) had conducted extensive field studies at 89 concrete dam sites in U.K. Figure 22.1 shows his correlation between velocity ratio and permeability measured by conventional packer tests. Velocity ratio is defined as a ratio between field velocity measured from seismic survey and velocity through rock core measured in the laboratory. It is essential that both the measurements are performed on saturated rocks. It may be noted that insitu permeability increases by ten thousand times with decrease in velocity ratio from 1.0 to 0.5 due to fractures.

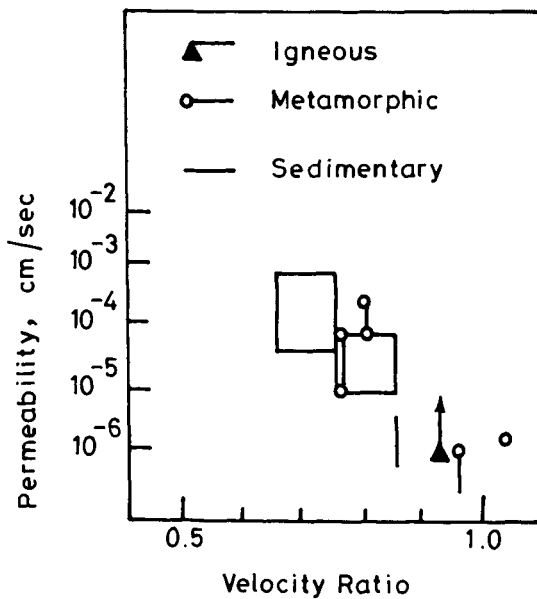

Figure 22.1: Correlation between insitu permeability and velocity ratio (Knill, 1969)

22.3 Permeability for Classifying Rock Masses

Houlsby (1977) has suggested a classification of rock masses according to their permeabilities as per following Table 22.2.

Permeability and groutability

TABLE 22.2
CLASSIFICATION OF ROCK MASSES ON THE BASIS OF LUGEON VALUES
(HOULSBY, 1977)

| Lugeon Value | Strong, massive rock with continuous jointing | Weak, heavily jointed rock |
|--------------|---|--|
| 0 | completely tight | completely tight |
| 1 | sometimes open joints upto about 1mm | sometimes open to hair crack size of 0.3mm |
| 3.5 | occasionally open to 2.5mm | occasionally open to 1.2mm |
| 20 | often open to 1.2mm | often open to 1.2mm |
| 50 | often open to 2.5mm | often open to 2.5mm |
| 100 | often open to 6.2mm | often open to 6.2mm |

Note: Joint measurements are in mm ; 1 lugeon = $1.3 \cdot 10^{-5}$ cm/sec. Local variation in permeability is probable due to locally open fractures

22.4 Permeability vs Grouting

Houlsby (1982) presented a very useful key note paper on cement grouting in dams. When is grouting warranted? This question has been answered well in Figure 22.2. If permeability is less than 1 lugeon, no grouting is required as the rock is likely to be tightly jointed and of good quality. If permeability is more than 10 lugeons, grouting is required for most types of dams. A permeability of 100 lugeons is encountered in a heavily jointed rock mass with relatively open joints (Table 22.2).

22.5 Determination of Permeability

The permeability of in-situ soils and rocks are usually determined by means of pumping test and or the water pressure test also called as the lugeon test.

22.5.1 Lugeon Test

Lugeon method or water pressure test is done in a drillhole. The test does not give permeability coefficient k . The test does, however, give a quantitative comparison of the insitu permeabilities. The lugeon test is generally performed for establishing a criterion for grouting of rock masses.

The approach developed by Professor Maurice Lugeon (1933), is based on the lugeon unit. The lugeon unit is obtained from water injection and absorption test in-situ. One lugeon unit corresponds to 1 liter of water absorption at the rate of 1 litre/minute from a one metre test length of a borehole when the water in the borehole remains at a pressure of 1MPa over a period of 10 minutes. Accordingly, a rock mass absorbing less than one lugeon unit of water is considered to be reasonably water tight, and so no grouting is needed.

WHEN IS GROUTING WARRANTED
 WHEN HAS ENOUGH GROUTING BEEN DONE
 WHEN PERMEABILITIES ARE THOSE SHOWN BELOW OR TIGHTER

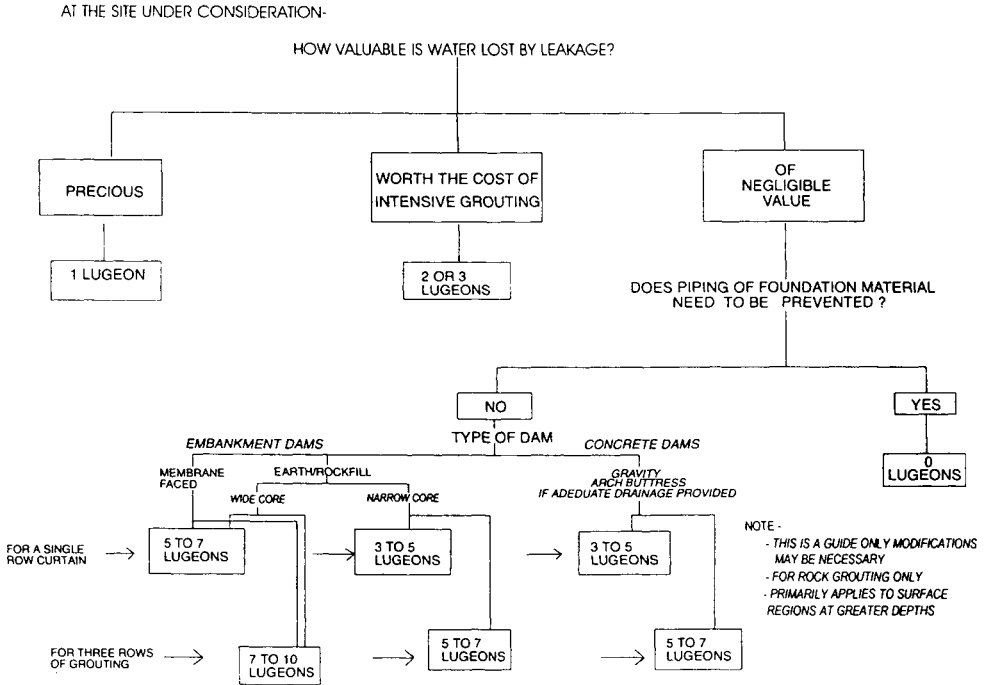

Figure 22.2: Guide for deciding when grouting is needed, and if so, to what intensity (Houlsby, 1982)

22.6 Grouting

“If in doubt, do not scream and shout, grout and grout throughout”

Grouting is a process of injecting a slurry of cement or other suitable material under pressure into a rock formation through a borehole to mend fissures and cracks. In most of the cases the purpose of the grouting is-

- to strengthen the ground or rock mass,
- to make the rock mass water tight, or
- both at the same time.

Permeability and groutability

If the rock mass has poor strength, grouting is aimed at improving its mechanical strength thereby allowing:

- * easier and safer excavation works,
- * construction through zones that are difficult to penetrate by traditional methods (e.g., cohesionless or flowing ground, thick shear zones, fault zones, etc.), and
- * passage through zones where environmental conditions are difficult.

Grouting for water proofing, on the other hand, is used to form curtains (below dams and around water conductor systems), capable of reducing the underground flow of water etc. It also provides acceptable tunnelling conditions, both for the work and the environment in :

- * rocks that are of good structure, however fissured, fractured, or strongly permeated with water,
- * highly permeable grounds that prove unstable.

Pre-grouting can be done from ground surface from an adjacent or pre-existing work, or directly from a gallery under construction. Consolidation grouting generally has a water proofing effect. Both types of grouting are often used below ground water level in underground works.

Grouting increases the modulus of deformation of rock masses. It cuts down the amount of discharge of seepage water, and with a judiciously installed drainage system, grouting may also contribute to reduce uplift pressure on hydraulic structures. All these improvements in rock properties improve the stability of rock structure system.

22.6.1 Grout Types

There are mainly following kinds of grouts:

- (i) Suspension grouts,
- (ii) Liquid or solution grouts, and
- (iii) Special grouts.

Suspension grouts

Suspension grouts are a combination of one or more inert products like cement, fly - ash, clays etc. suspended in a liquid, i.e., water. Depending on the dry matter content, suspension grouts can be classified as either stable or unstable.

Unstable suspensions are a mixture of pure cement with water. This mixture is homogenized by an agitation process. A sedimentation of suspended particles occurs rapidly when agitation stops.

Stable suspensions are generally obtained by using the following methods:

- * increasing the total dry matter content.

- * incorporating a mineral or colloidal component, often from the bentonite family, and
- * incorporating sodium silicate in cement and clay/cement suspensions.

The apparent stability depends on the dosage of various components and on the agitation process. The stability is relative because sedimentation occurs more or less rapidly when agitation ceases.

Liquid grouts

Liquid grouts consist of chemical products, in a solution or emulsion form, and their reagents. The most frequently used products are sodium silicate and certain resins. Hydrocarbon emulsions can also be used in specific cases.

Special grouts

Special grouts have one or more special features. These are quick setting grouts, cellular type grouts (expanding or swelling grout and expanded or aerated grout), and grouts with improved special property.

Quick-setting grouts

Setting times for these grouts have been modified. In some cases the setting time may be reduced to a few seconds. The products used for quick setting grouts include:

- * Pure cement based grout - Among additives, most commonly used are accelerators such as calcium chloride and sodium silicate. Portland cements and aluminous cement mixes are also used.
- * Bentonite/cement grout - The most commonly used accelerator is sodium silicate.

Expanding or swelling cellular type grout

The volume of this type of grout increases after the grout is placed. Swelling of the grout is obtained through formation of gas inside the grout itself. Expansion is generally more than 100 per cent. These grouts are used for filling large solution cavities in soluble rocks like limestones.

The cells are most often obtained by the formation of hydrogen, caused by the action of lime element in cement on aluminum powder incorporated in the grout at mixing time. Immediate stability of the grout can be improved by adding small quantities of sodium silicate. The quantity of aluminum powder in the grout may be upto 2 kg/m^3 . At many projects, rock anchors are being installed using cement grout but without aluminium powder. Consequently, cement grout shrinks after setting and the pull-out capacity of anchors decreases to miserably low values. There is thus a need for quality control of grout materials used in ground/rock anchors.

Permeability and groutability

Expanded or aerated cellular type grouts

The volume of these grouts is increased before use by introducing a certain volume of air. Air is added by introducing a wetting agent when the grout is mixed. This operation can be made easier by blowing air into the grout during preparation. The objective with aerated grout is to increase the grout volume by forming bubbles. The volume generally increases by 30-50 per cent before the grout is injected. These types of grouts are used to fill cavities so that a compacting effect occurs in a closed space.

Grouts with improved special properties

Grout with improved penetrability - The objective in this case is to obtain a grout capable of penetrating voids smaller than those usually filled, and also to reach even farther, if necessary. Various methods are used to increase cement grout penetrability:

- (a) By decreasing viscosity and shearing strength using additives with a fluidifying action in the constant presence of dry matter. The additives are used to deflocculate bunches of grains that form in the usual grouts. These products can be derived from natural organic products, e.g. sodium bicarbonate in certain cases.
- (b) By increasing resistance to filtering effects using activators that reduce grout filtration. This is obtained by dispersion of grout grains (or peptizing agents) or through the action of water retaining polymers on inter-granular water.
- (c) By decreasing the dimensions of the grains suspended in grouts. This is a costly alternative which involves regrinding of material.

Grouts with improved mechanical strength - The objective of this type of grout is to obtain an increased final strength of grouts, either by applying a treatment that does not modify certain other characteristics, such as dry matter content or viscosity, or by using additives that are cheaper than the constructive products of the original grout.

Grout with an improved resistance to washing-out - These types of grouts are used in order to avoid any washing out processes when the grouts are applied in largely open spaces filled with water, and particularly when flowing water is present. This is achieved:

- (a) By using hardened grouts which are almost instantaneous and in some cases halting the washing out process. Controlling the hardening time also permits penetrability to be controlled.
- (b) By improving resistance through the use of flocculating, coagulating or thickening types of organic additives. These additives improve the resistance to washing-out tendencies. These also increase viscosity and cohesion which, in turn, tend to modify grout rheology as well as the behaviour at the grout-water separation surface.

Details on grouts can be obtained from a ITA Special Report: *Grouting of Underground Works, 1991*.

22.6.2 Grouting Parameters

Three main parameters must be taken into account to control grout injection process.

- (i) the grout volume V per pass,
- (ii) the injection pressure P , and
- (iii) the rate of injection output Q .

These parameters are determined by a set of injection points and relate to one injection phase. The following fourth parameter has to be checked:

- (iv) the time of injection t for one pass, where $t = V/Q$ average, which must be in accordance with the setting time.

The volume V depends upon the volumetric ratio, defined as grout volume/volume of treated ground, which integrates the porosity of the ground, the filling coefficient of voids for the phase under consideration and the geometry of treatment given by spacing between holes and length of the injection pass.

The speed Q must be limited so that the injection pressure P remains lower than the ground fracturing pressure which depends on insitu stresses. Therefore, an experimental approach with regard to P and Q parameters is recommended in order to assure that the treatment is accomplished correctly.

Figure 22.3 shows a correlation between grout-take, field velocity and velocity ratio for grout curtains. This is as per grouting practice in terms of a pound of cement or cement plus filler per square foot of cut off. Knill (1969) pointed out that correlations for other countries will differ and data may be too scattered. Nevertheless, the advantage of classifying rock masses is brought out clearly.

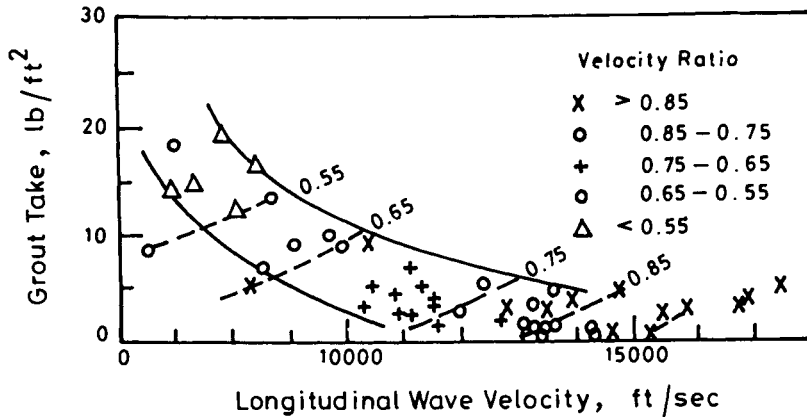

Figure 22.3: Correlation between grout take, longitudinal wave velocity and velocity ratio (Knill, 1969)

Permeability and groutability

For consolidation grouting, limited available data suggests the following correlation (Figure 22.3).

$$\% \text{ voids infilling} = (0.04) \cdot \text{grout take} \quad (22.1)$$

The grout take depends upon field wave velocity. If a rock mass is not fully saturated, some allowances must be made for recording velocity on the lower side. On the contrary, velocities may be observed to be on the higher side in the area of tectonic stresses. Other factors affecting the velocity are anisotropy, joint system and presence of wave guide, if any. Hence, the limitation of the classification system based solely upon the velocity ratio. Further, field studies are needed to update trends observed by Knill (1969).

The effectiveness of consolidation grouting may be checked by observing improvements in RQD and field velocity after grouting. For example, if velocity ratio is raised to a value more than 0.85 and field velocity becomes more than 13000 ft./sec (4300 m/sec), the grouting operation may be regarded successful.

22.6.3 Effectiveness of Grouting

Effectiveness of grouting may be checked in a better way by measuring the permeability in new drill-holes. If the permeability of a rock mass at shallow depths has been reduced considerably to the extent as shown in Figure 22.2, no further grouting is required.

Regarding grout pressure, the well known rule of thumb of 1psi per foot is usually a good compromise for a rock mass of poor quality. Figure 22.4 gives the current trend.

Shortcomings of grouting is "working blind", because there is little control on where the grout is moving. Therefore, complete filling of all rock voids is not possible to ensure.

On the basis of the characteristics of the time-pressure diagrams plotted during the process of grout injection (Figures 22.5a to 22.5c), Jahde (1937) suggested an approach to identify whether grouting is successful or not.

Figure 22.5a shows that pressure increases slowly and uniformly until the pump capacity, or the allowable injection pressure is attained. This may be interpreted as successful injection.

Figure 22.5b indicates that the pressure drops after an initial increase. This may mean that the grout has "broken out". For example, a clay gauge, filling a crack that might have ended in the free atmosphere, has been expelled out of the crack. Accordingly, it can be inferred that the injection is successful.

Figure 22.5c conveys the idea that after an initial increase in pressure, the pressure drops, and again increase slowly. This may be interpreted that after the occurrence as in Figure 22.5b, the crack, or seam, or a joint did subsequently close and that the injection is successful.

The effectiveness of grouting operation is usually verified by making check borings in the grouted zone and examining rock cores extracted from these boreholes.

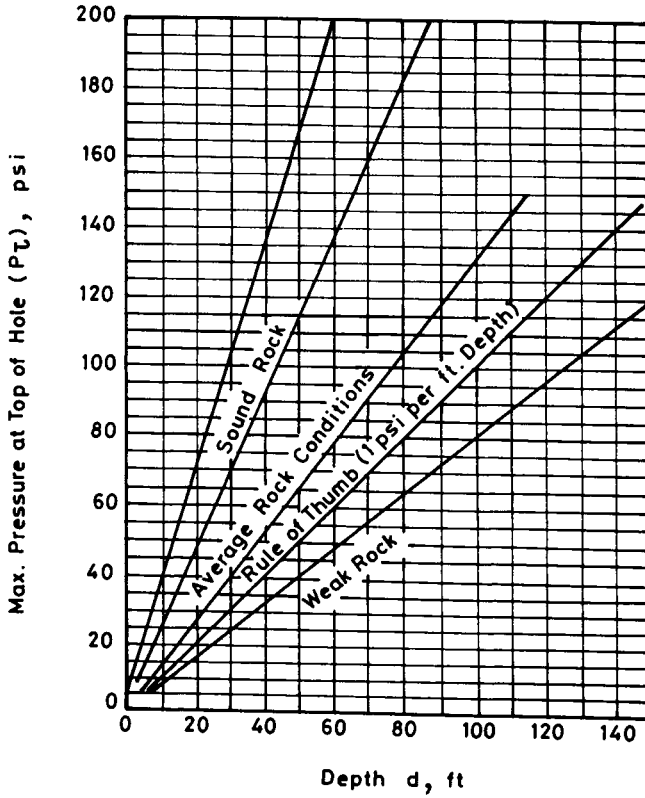

Figure 22.4: Recommended maximum grout pressures

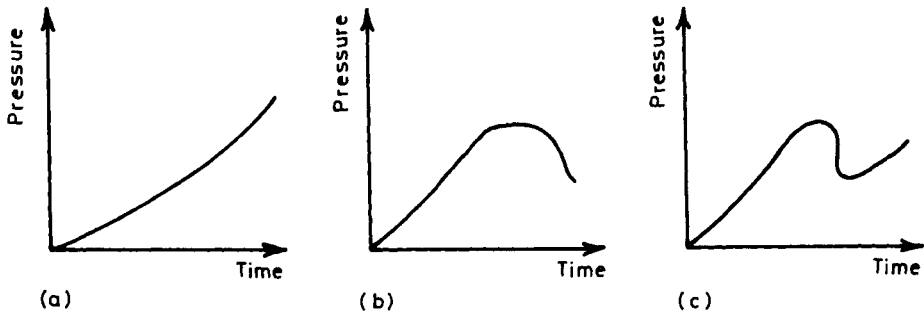

Figure 22.5: Plots to check the success of grouting (Jahde, 1937)

22.6.4 Heaving of Foundation upon Grouting

Grouting is injurious to a rock mass if it heaves due to an injecting pressure which are more than the overburden pressure. Heaving should be monitored to control the injecting pressure. A practical approach is to undertake grouting in different stage, the first stage at a low pressure and subsequent stages at stepped up pressure, reaching the final pressure at the end. Grouting of dam abutments may destabilize rock slopes and cause landslide because effective normal pressure across plane of sliding is reduced. Thus grouting should be done very carefully and under cautious supervision. This aspect could be critical when joints open on the slope.

References

- Houlsby, A. C. (1977). Engineering of Grout Curtains to Standards. *ASCE* , **Vol. 103**, GT 9, pp. 53-70.
- Houlsby, A. C. (1982). Cement Grouting for Dams, Key note paper. *ASCE Symp. Grouting in Geotechnical Engineering*, ed. by W.H. Baker, New Orleans, pp. 1-33.
- ITA Special Report . (1991). Grouting Underground Works: Recommendations on Grouting for Underground Works, Association Francaise des Travaux Souterrain, ITA, *Jr. Tunnelling and Underground Space Technology*, Pergamon, **Vol. 6, No. 4**, pp. 383-461.
- Jahde, H. (1937). Die Abdichtung des Untergrundes beim Tals perrenbau, Beton und Eisen, No. 12, p.193 (in *Rock Mechanics* by Jumikis, A. R., 1983)
- Jumikis, A. R. (1983). Rock Mechanics. IInd edition, *Trans Tech Publications*, p. 613.
- Knill, J. L. (1969). The Application of Seismic Methods in the Prediction of Grout Take in Rock, *Proc. Conf. on Insitu Investigations in Soils and Rocks*, London, pp. 93-99.
- Lugeon, M. (1933). Barrages et Geology Methods des Recherches, *Terrassement et Impermeabilization Lausanne: Librairie de l'universite' F. Rouge et cie, S. A.*, p. 87.

GOUGE MATERIAL

23.1 Gouge

Gouge is a finely graded material occurring between the walls of a fault, a joint, a discontinuity, etc. as a result of grinding action of rock joint walls. In other words, gouge is a filling material such as silt, clay, rock flour and other kind of geological debris in joints, cracks, fissures, faults and other discontinuities in rocks.

The study of gouge material is important from the point of stability of underground openings, slopes and foundations.

Brekke and Howard (1972) (Hoek and Brown, 1980) have presented seven groups of discontinuity infillings or gouges which have significant influence upon the engineering behaviour of rock masses.

- (i) Joints, seams and sometimes even minor faults may be healed through precipitation from solutions of quartz or calcite. In this instance, the discontinuity may be "welded" together. Such discontinuities may, however, have broken up again, forming new surfaces. Also, it should be emphasized that quartz and calcite may be present in a discontinuity not always healing it.
- (ii) Clean discontinuities, i.e., without fillings or coatings. Many of the rough joints or partings will have a favourable character. Close to the surface, however, it is imperative not to confuse clean discontinuities with "empty" discontinuities from where filling material has been leached and washed away due to surface weathering.
- (iii) Calcite fillings may dissolve due to seepage during the lifetime of an underground opening, particularly when they are porous or flaky. Their contribution to the strength of the rock mass will then, of course, disappear. This is a long-term stability (and sometimes fluid flow) problem that can easily be overlooked during design and construction. Gypsum fillings may behave the same way.
- (iv) Coatings or fillings of chlorite, talc and graphite make very slippery (i.e., low strength) joints, seams or faults particularly when wet due to the loss of cohesion.
- (v) Inactive clay material in seams and faults naturally represents a very weak material that may squeeze or wash out.
- (vi) Swelling clay gouge may cause serious problems through free swell and consequent loss of strength, or through considerable swelling pressure when confined by a tunnel lining.

Gouge material

- (vii) Material that has been altered to a more cohesionless material (sand-like) may run or flow into a tunnel immediately after excavation.

23.2 Influence of Gouge Material

Brekke and Howard (1972) have summarized the consequences of encountering filled discontinuities during tunnel excavation as shown in Table 23.1.

TABLE 23.1
INFLUENCE OF DISCONTINUITY INFILLING UPON THE BEHAVIOUR OF TUNNELS
(BREKKE & HOWARD, 1972)

| Dominant Material in Gouge | Potential Behaviour of Gouge Material | |
|--|---|--|
| | Near Face of Tunnel | Later |
| Swelling clay | Free swelling, sloughing. Swelling pressure and squeezing pressure on shield | Swelling pressure and squeezing pressure against support or lining, free swell with down-fall or wash - in if lining is inadequate |
| Inactive clay | Slaking and sloughing caused by squeezeing pressure. Heavy squeezing pressure under extreme conditions. | Squeezeing pressure on supports of lining where unprotected, slaking and sloguhing due to environmental changes |
| Chlorite, talc, graphite or serpentine | Ravelling | Heavy loads may develop on tunnel supports due to low strength, particularly when wet |
| Crushed rock fragments; sand-like | Ravelling or running. Stand-up time may be extremely short | Loosening loads on lining, running and ravelling, if unconfined |
| Porous or flaky calcite, gypsum | Favourable conditions | May dissolve, leading to instability of rock mass |

If the gouge consists of montmorillonite clay mineral, variation in its moisture content may bring about catastrophic instability of the rock slope. Any clay gouge in a sloped discontinuity makes the rock mass to slide easily and when such a gouge becomes wet, it promotes sliding of the rock blocks. In either case, the presence of a significant thickness of gouge has a major influence on the stability of a rock mass (Hoek and Bray, 1981). Figure 23.1 shows idealized picture of rough undulating joints (Barton, 1974), which has the following four types of clay fillings.

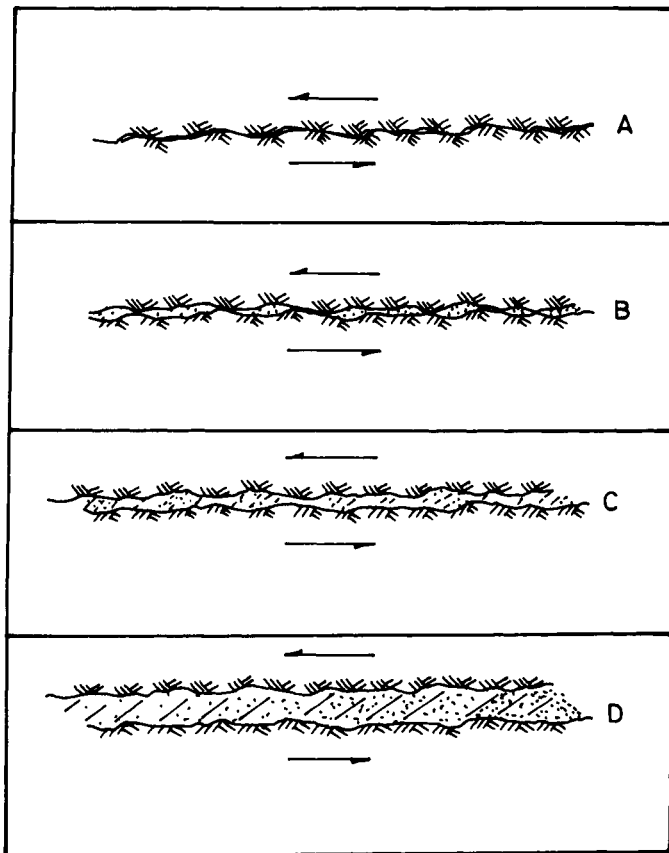

Figure 23.1: Categories of discontinuities according to the filling thickness (Barton, 1974)

- (i) The category A indicates direct rock/rock asperity contact. The shear strength will be little different from the unfilled strength because the rock /rock contact area at peak strength is always small. Dilation due to rock / rock contact will cause negative pore pressures to be developed infilling if shearing rate is fast due to a nearby high intensity earthquake.
- (ii) The category B may develop the same amount of rock / rock asperity contact as in category A, but the required displacement may be larger. Dilation component of peak shear strength is greatly reduced since the peak strength is similar to the residual strength for unfilled joints. There will be less tendency for negative pore pressures due to reduced dilation.

Gouge material

- (iii) The category C does not show an occurrence of rock /rock contact but there will be a build up of stress in the filling where the adjacent rock asperities come close together. If the shearing rate is fast there will be increase in pore pressures in these highly stressed zones and the shear strength will be low. If, on the other hand, the shearing rate is low, consolidation and drainage will occur. The drainage towards the low stress pockets on either side of the consolidation zones, results in marked increase in shear strength as compared to that under fast shearing rate.
- (iv) The category D indicates that when the discontinuity filling has a thickness several times that of the asperity amplitude, the influence of the rock walls will disappear provided the filling is uniformly graded and predominantly clay or silt. The strength behavior will be governed by usual principles of Geotechnical Engineering.

Goodman (1970) demonstrated the importance of joint infillings in a series of tests, in which artificially created saw tooth joint surfaces were coated with crushed mica. The decrease in shear strength with the increase in filling thickness is shown in Figure 23.2 which indicates that once the filling thickness (t) exceeds the amplitude (a) of the surface projections, the strength of the joint is controlled by the strength of the filling material.

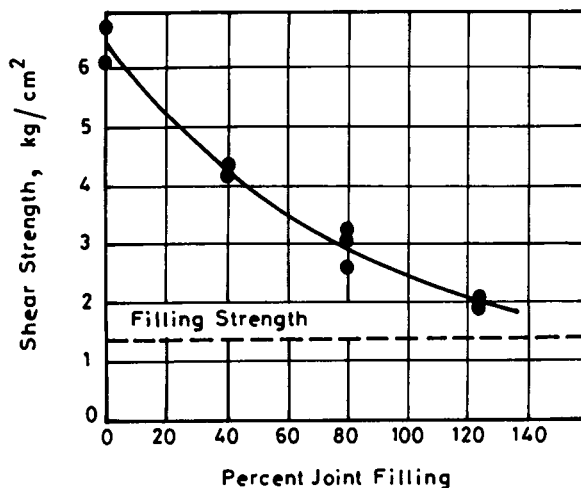

Figure 23.2: Effect of joint filling thickness on shear strength (Goodman, 1970)

Goodman, Heuze and Ohnishi (1972) examined the influence of thickness (t) of the filling material (kaolinite clay) in granite and sandstone joints. They reported that for very small thickness of filling material, there is augmentation of the strength by virtue of the geometry of the rough joint walls. As the thickness increased, the clay filling revealed reduction in strength. At a ratio of thickness and amplitude, (t/a) of 3, the strength was reduced to that of the filling material.

23.3 Shear Strength of Filled Discontinuities (Silty to Clayey Gouge)

Sinha (1993) simulated successfully the filled discontinuity in a slope in triaxial tests on two 38mm ϕ perspex cylinders with inclined saw-tooth joints which were filled with remoulded gouge. The study by Sinha (1993) has brought out the following strength criteria for a thick gouge,

- (i) Deviator stress which controls the shear failure is a better criterion for evaluating shear strength of a joint with a thick gouge ($t/a > 1.25$). Accordingly, following modifications in Eq. 14.5 (Barton, 1974 & 1987) have been made for evaluation of shear strength of a rock joint with a clay gouge and $t/a > 1.25$.

(a) *for undulating joints*

$$\frac{\sigma_1 - \sigma_3}{2} = \sigma_n' \cdot f_t \cdot \tan [\text{JRC} \log_{10} \frac{\sigma_1 - \sigma_3}{\sigma_n'} + \phi_b'] \quad (23.1)$$

(b) *for planar joints*

$$\frac{\sigma_1 - \sigma_3}{2} = \sigma_n' \cdot f_t \tan \phi_b' \quad (23.2)$$

where,

- σ_n' = effective normal stress on joint plane,
- f_t = correction factor due to thickness of gouge (t/a),
 - = $0.98 + 0.96 e^{(-t/a)}$ for undulating joints,
 - = $0.80 + 0.61 e^{(-t)}$ for planar joints,
- t = thickness of gouge in metres,
- JRC = joint roughness coefficient as shown in Chapter 14 (range 0 to 20),
- ϕ_b' = basic frictional angle,
- $(\sigma_1 - \sigma_3)/2$ = maximum shear stress as obtained after conducting triaxial tests on joints filled with gouge, and
- β = angle between joint plane and major principal stress plane ($\beta > \phi_b'$ for failure to occur)

Further, it is observed by Sinha (1993) that at higher thickness of gouge ($t > 20$ mm), σ_n' becomes less than $\sigma_1 - \sigma_3$ resulting in compaction (negative dilation) of the gouge.

- (ii) On the basis of experimental data, a non-linear relationship for the shear modulus of gouge in joints is found to be,

$$\frac{G}{G_0} = 1.46 + 7.13 e^{-(t/a) \tan \beta} \quad \text{undulating joints} \quad (23.3)$$

Gouge material

$$\frac{G}{G_0} = 1.10 + 3.48 e^{-(t/a) \tan \beta} \quad \text{planar joints} \quad (23.4)$$

where,

- G/G_0 = normalized shear modulus,
- G = shear modulus,
- G_0 = shear modulus of gouge of very large thickness ($t \gg a$),
- t/a = thickness-amplitude ratio,
- β = dip angle (angle between joint plane and major principal plane), and
- t = thickness of gouge in mm.

This testing technique has been appreciated by NGI scientists and further studies are in progress on over-consolidated clayey gouge and larger diameter samples (d/t).

It may be mentioned that the dynamic shear modulus will be much higher than the static modulus because dynamic strain is very small.

23.4 Dynamic Strength

Shear zones near slopes may have over-consolidated clayey gouge due to erosion of the overburden. Thus, there may be some cohesive resistance, particularly in joints having over-consolidated clayey gouge. Under seismic loading the dynamic cohesion may increase enormously because of negative pore water pressure ($PI > 5$).

$$c_{\text{dyn}} = c_{\text{consolidated undrained}} \quad (23.5)$$

Further, particles of soil and rock take some time to slip with respect to each other due to inertial forces of particles and lack of time for creep during seismic loading. So, much higher dynamic stress is needed to develop failure strain. Consequently, dynamic strength enhancement in cohesion is likely to be very high along discontinuities filled with over-consolidated clayey gouge ($PI > 5$) under impulsive seismic loading due to a high intensity earthquake with nearby epicentre. Further research is needed on dynamic behaviour of filled discontinuities.

References

- Barton, N. (1974). A Review of the Shear Strength of Filled Discontinuities in Rock. *NGI Publication No. 105*, Oslo, pp. 1 - 48.
- Barton, N. (1987). The Shear Strength of Rock and Rock Joints, *Current Practices in Geotechnical Engineering, Vol. 4*, (Editors Alam Singh and M.L. Ohri, University of Jodhpur, Jodhpur, Associated Publishers IBT & Geo-Environ Academica), pp. 149 - 202.
- Brekke, T. L. and Howard, T. (1972). Stability Problems Caused by Seams and Faults. Proc. *First North American Rapid Excavation and Tunnelling Conference*, AIME, New York, pp. 25-41.

- Goodman, R. E. (1970). Deformability of Joints, Determination of the Insitu Modulus of Deformation of Rock, *Sym. Denver*, Colo, 1969, ASTM, Special **Technical Publication 477**, pp. 174 - 196.
- Goodman, R. E., Heuze, F. E. and Ohnishi, Y. (1972). Research on Strength, Deformability, Water Pressure Relationship for Faults in Direct Shear, *Reprint University of California*, Berkeley, USA.
- Hoek, E. and Bray, J. M. (1974 and 1981). *Rock Slope Engineering*, Institute of Mining and Metallurgy, London, Chapter 5, pp. 83-126 and 150 - 270.
- Hoek, E. and Brown, E. T. (1980). *Underground Excavations in Rock*, Institution of Mining and Metallurgy, Chapter 2, pp. 20-25.
- Sinha, U. N. (1993). Behaviour of Clayey Gouge Material Along Discontinuity Surfaces in Rock Mass, *Ph. D. Thesis, University of Roorkee*, India, p.290.

CHAPTER - 24

ENGINEERING PROPERTIES OF HARD ROCK MASSES

24.1 Hard Rock Masses

Hard rock masses are encountered in a majority of countries and extensive underground excavation work is being carried out through such rocks. It is planned to discuss the engineering properties of hard rock masses in this chapter separately for ready reference.

The properties of hard rock masses are required for designing engineering structures. Hard rock is defined as rock material having UCS of more than 100 MPa. On the other hand, hard rocks are geologically very old and have well developed and highly weathered joints. Therefore, there may be serious problems of rock falls and seepage in tunnels due to such joints, if left unsupported. Experience shows that a hard rock is a misnomer as engineers may believe that it will not pose problems of instability. The deceptive nice appearance created many construction problems in the past in the tunnels of South India, upper Himalaya, Alps and the U.S.A.

24.2 Modulus of Deformation

In the case of rock foundations, knowledge of deformation modulus of rock masses is of prime importance. The geomechanics classification is a useful method for estimating in-situ deformability of rock masses (Bieniawski, 1978). As shown in Figure 6.3, the following correlation is obtained:

$$E_d = 2 \text{ RMR} - 100 \quad \text{GPa} \quad (24.1)$$

where E_d is in-situ modulus of deformation in GPa for $\text{RMR} > 50$, and RMR is discussed in Chapter 6.

24.3 Uniaxial Compressive Strength (UCS)

Grimstad and Bhasin (1995) have proposed the following correlation for mobilized uniaxial crushing strength (UCS) for good and massive rock masses in tunnels:

$$q_{\text{cmass}} = 7 \gamma f_c Q^{1.3} \quad \text{MPa} \quad (24.2a)$$

where $f_c = \frac{q_c}{100}$ for $Q > 10$ and $q_c > 100$ MPa, other wise $f_c = 1$, and γ is unit weight of the rock mass in gm/cc.

Laubscher (1984) found UCS for hard rock masses in mines which is also nearly the same as above UCS (Eqn. 24.2a).

$$q_{\text{mass}} = q_c \cdot \frac{(\text{RMR} - \text{rating for } q_c)}{106} \quad (24.2b)$$

24.4 Uniaxial Tensile Strength (UTS)

Uniaxial tensile strength of a rock mass is obtained by using Eqn. 24.3

$$q_{\text{tmass}} = 0.029 \cdot \gamma \cdot f_c \cdot Q^{0.3} \quad \text{MPa} \quad (24.3)$$

24.5 Strength Criterion

The UCS of massive hard rock mass is approximately the same as that of its rock material. However, small size correction in q_c is needed as shown in Eqn. 10.4. The shear strength of hard rock masses proposed by Hoek and Brown (1980) is proportional to average value of UCS of the rock material q_c (after size correction),

$$\sigma_1 = \sigma_3 + [m \cdot q_c \cdot \sigma_3 + s \cdot q_c^2]^{1/2} \quad (24.4)$$

For massive rock masses, $s = 1$

For tunnels / caverns, $s^{1/2} = \frac{7 \cdot \gamma \cdot q_c Q^{1/3}}{100} = \text{strength reduction factor}$ and

$$\frac{m}{m_r} = s^{1/3}$$

For slopes, rock parameters 'm' and 's' are related to Geological Strength Index (GSI) in Chapter 25, which may be used for slopes, dam abutments and foundations.

In the case of overstressed dry massive hard rocks, sudden failure by rock bursts may take place as in Kolar Gold mines in India and hard rock mines in South Africa. Chances of rock burst will be more if a hard rock is of Class II type (Chapter 3). In weak rock masses, squeezing may take place rather than violent failure.

Reservoir Induced Seismicity (RIS) is more pronounced due to dam reservoirs in hard rocks, e.g. Koyna Hydroelectric Project, India, etc. In weak rock masses, RIS is low due to its high damping characteristics.

24.6 Support Pressure in Non-squeezing/Non-Rock Burst Conditions ($H < 350 Q^{1/3}$)

The ultimate support pressure in underground caverns with overburden H in metres may be found from Eqn. 8.10 which is also produced here as Eqn. 24.5

$$p_{ult} = \frac{0.2}{J_r} \cdot f \cdot Q^{-1.3} \quad , \text{ MPa} \quad (24.5)$$

where $f = 1 + (H - 320)/800 \geq 1$

Tunnels may be self-supporting where its width or diameter B is less than the self-supporting span B_s given by,

$$B_s = 2 \cdot Q^{0.4} \quad \text{metres} \quad (24.6)$$

General requirements for permanently unsupported openings are,

(a) $J_n < 9, J_r > 1.0, J_a < 1.0, J_w = 1.0, \text{SRF} < 2.5$

Further, conditional requirements for permanently unsupported openings are given below.

- (b) If $\text{RQD} < 40$, need $J_n < 2$
- (c) If $J_n = 9$, need $J_r > 1.5$ and $\text{RQD} > 90$
- (d) If $J_r = 1.0$, need $J_w < 4$
- (e) If $\text{SRF} > 1$, need $J_r > 1.5$
- (f) If span > 10 m, need $J_n < 9$
- (g) If span > 20 m, need $J_n < 4$ and $\text{SRF} < 1$

In the geologically old and matured hard rock masses, joints may be highly weathered due to very long period of weathering. Thus, small wedge failures in unsupported tunnels are not uncommon. Further, water charged rock masses may also be encountered, particularly during heavy rainy seasons.

24.7 Half - Tunnels

Half tunnels generally, have been excavated along hill roads passing through steep hills in hard rocks (Figure 24.1). Such tunnels are most common in H.P., India. The top width B_{ht} has been estimated from 11 case records of half - tunnels,

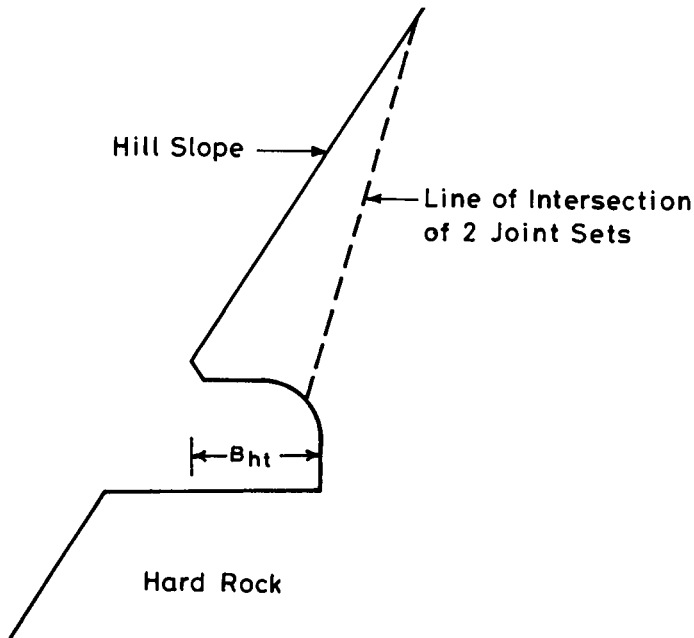

Figure 24.1: Half-tunnel along hill roads in hard rocks

$$B_{ht} = 1.7 Q^{0.4} \quad \text{metres} \quad (24.7)$$

Joints at these sites were discontinuous and the number of joint sets were not more than two with $Q > 18$ (SRF = 2.5). These unsupported half-tunnels have been stable for more than 2 decades. The factors of safety of wedges formed by 2 joint sets and slope were found to be more than 3 against sliding along inclined lines of intersection of joint planes (Figure 24.1). These half-tunnels saved ecological disturbance because near vertical cut-slopes would be very closely and ecologically unsound. The half-tunnels are also tourist attraction and considered engineering marvel.

References

- Bieniawski, Z. T. (1978). Determining Rock Mass Deformability: Experience from Case Histories, *Int. Jr. Rock Mech. and Min. Sci. & Geomech. Abstr.*, Pergamon, **Vol. 15**, pp. 237-247.
- Laubscher, D. H. (1984). Design Aspects and Effectiveness of Support System in Different Mining Conditions, *Trans. Inst. Mining and Metallurgy*, **Vol. 93**, pp. A70-81.

Engineering properties of hard rock masses

- Mehrotra, V. K. (1996). Failure Envelopes for Jointed Rocks in Lesser Himalaya, *Jr. Rock Mech. and Tunnelling Technology*, India, **Vol. 2, No. 1**, pp. 59-74.
- Singh, Bhawani., Viladkar, M. N., Samadhiya, N. K. and Mehrotra, V. K. (1997). Rock Mass Strength Parameters Mobilized in Tunnels, *Jr. Tunnelling and Underground Space Technology*, Pergamon, **Vol. 12, No. 1**, pp. 47-54.

CHAPTER - 25

GEOLOGICAL STRENGTH INDEX (GSI)

"The function of Rock Mechanics Engineers is not to compute accurately but to judge soundly"

Hoek and Londe

25.1 Geological Strength Index (GSI)

Hoek and Brown (1997) introduced recently the Geological Strength Index (GSI), both for hard and weak rock masses. Experienced field engineers and geologists generally show a liking for a simple, fast, yet reliable classification which is based on visual inspection of geological conditions. Past experiences suggest that a classification system should be non-linear for poor rocks as strength deteriorates rapidly with weathering. Further, increased applications of computer modelling has created an urgent need for a classification system tuned specially to computer simulation of rock structures. To meet these needs, Hoek and Brown (1997) devised simple charts for estimating GSI based on the following two correlations:

$$\text{GSI} = \text{RMR} - 5 \quad \text{for GSI} \geq 18 \text{ or } \text{RMR} \geq 23 \quad (25.1)$$

$$= 9 \ln Q' + 44 \quad \text{for } \text{GSI} < 18 \quad (25.2)$$

where,

$$\begin{aligned} Q' &= \text{modified tunnelling quality index} \\ &= [\text{RQD}/J_n] \cdot [J_r/J_a] \end{aligned} \quad (25.3)$$

RMR = Rock Mass Rating according to Bieniawski (1989)

Sometimes, there is difficulty in obtaining RMR in poor rock masses. The Q' may thus be used more often as it is relatively more reliable than RMR, specially in weak rocks.

Hoek and Brown (1997) have recently proposed a chart for GSI (Table 25.1) as experts can classify a rock mass by visual inspection alone. In this classification, there are four main qualitative classifications, adopted from Terzaghi's classification (Table 5.3).

- (i) Blocky
- (ii) Very Blocky
- (iii) Blocky / Folded
- (iv) Crushed

Geological strength index (GSI)

Engineers and geologists are already familiar with it for 50 years. Further, discontinuities are classified into 5 surface conditions which are similar to joint conditions in RMR (Chapter 6).

- (i) Very Good
- (ii) Good
- (iii) Fair
- (iv) Poor
- (v) Very Poor

Now a block in the matrix of 4 x 5 of Table 25.1 is picked up according to actual rock mass classification and discontinuity surface condition. Then corresponding GSI is read. According to Hoek (1998), a range of values of GSI (or RMR) should be estimated in preference to a single value. This practice has a significant impact on design of slopes and excavations in rocks.

For avoiding double accounting, ground water condition and insitu stresses are not considered in GSI as these are accounted for in computer models. Further, GSI assumes that the rock mass is isotropic. Therefore, only cores without weak planes should be tested in triaxial cell to determine q_c and m_r as GSI down-grades strength according to schistosity.

Obviously, an undisturbed rock mass should be inspected for classification. However, heavy blasting creates new fractures. So, Hoek and Brown (1997) have recommended addition of 10 points to the geological strength index for a seriously blast-damaged rock mass to obtain GSI of the undisturbed rock mass.

25.2 Modified Strength Criterion

Hoek (1994) has suggested the following modified strength criterion for a rock mass

$$\sigma_1 = \sigma_3 + q_c \left[m \frac{\sigma_3}{q_c} + s \right]^n \quad (25.4)$$

where,

σ_1 = maximum effective principal stress,

σ_3 = minimum effective principal stress,

q_c = UCS of rock material (intact) for standard NX size core,



m = rock mass constant,

$$S^n = \text{strength reduction factor} = \frac{q_{c\text{mass}}}{q_c}, \quad (25.5)$$

$n = 0.5$ for $GSI \geq 25$, and

$$= 0.65 - \left(\frac{GSI}{200} \right) \leq 0.60 \quad \text{for } GSI < 25 \quad (25.6)$$

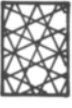
TABLE 25.1
ESTIMATE OF GEOLOGICAL STRENGTH INDEX GSI BASED ON VISUAL INSPECTION OF
GEOLOGICAL CONDITIONS (HOEK AND BROWN, 1997)

| GEOLOGICAL STRENGTH INDEX | | DISCONTINUITY SURFACE CONDITION | | | | |
|---|---|---|--|--|---|--|
| According to geological conditions, pick the appropriate box in this chart. Estimate the average value of the Geological Strength Index GSI from the contours | | VERY GOOD Very rough, unweathered surfaces | GOOD Rough, slightly weathered, iron stained surfaces | FAIR Smooth, moderately weathered or altered surfaces | POOR Slickensided, highly weathered surfaces with compact coatings or fillings containing angular rock fragments | VERY POOR Slickensided, highly weathered surfaces with soft clay coatings or fillings |
| STRUCTURE | | | | | | |
|  | BLOCKY - very well interlocked undisturbed rock mass consisting of cubical blocks formed by three orthogonal discontinuity sets | 80 | 70 | | | |
|  | VERY BLOCKY - interlocked, partially distributed rock mass with multifaceted angular blocks formed by four or more discontinuity sets | | 60 | 50 | | |
|  | BLOCKY/FOLDED - folded and faulted with many intersecting discontinuities forming angular blocks | | | 40 | 30 | |
|  | CRUSHED - poorly interlocked, heavily broken rock mass with a mixture of angular and rounded blocks | | | | 20 | 10 |

Geological strength index (GSI)

Hoek (1994) and Hoek and Brown (1997) have found the following correlation from the back analysis of instrumented openings and slopes,

$$m = m_r \cdot e^{\left(\frac{GSI - 100}{28}\right)} = 0.135 \cdot m_r \cdot (Q')^{1/3} \quad (25.7)$$

$$s = e^{\left(\frac{GSI - 100}{9}\right)} \quad \text{for } GSI > 25 \quad (25.8)$$

$$= 0.002 \cdot Q = J_p^{1/n}$$

$$s = 0 \quad \text{for } GSI < 25$$

where,

m_r = rock material constant to be found from triaxial tests on rock cores, and

J_p = jointing parameter (Palmstrom, 1995) in Chapter 10.

Equations 25.7 and 25.8 may be simplified as follows :

$$\frac{m}{m_r} = s^{1/3} \quad \text{for } GSI > 25 \quad (25.9)$$

Thus, uniaxial compressive strength of a rock mass obtained from Eqn. 25.5 is,

$$q_{c\text{mass}} = q_c \cdot s^n \quad (25.10)$$

and uniaxial tensile strength of a good rock mass ($GSI > 25$, $n = 0.5$) is

$$q_{t\text{mass}} = q_c \cdot (m/s) \quad (25.11)$$

25.3 Mohr-Coulomb Strength Parameters

Mohr-Coulomb's strength criterion for a rock mass is expressed as follows,

$$\sigma_1 - \sigma_3 = q_{c\text{mass}} + A \sigma_3 \quad (25.12)$$

where,

$q_{c\text{mass}}$ = uniaxial compressive strength of the rock mass,

$$= 2c \cos\phi / (1 - \sin\phi)$$

c = cohesion of the rock mass,

A = $2 \sin\phi / (1 - \sin\phi)$,

ϕ = angle of internal friction of the rock mass.

Hoek and Brown (1997) have made extensive calculations on linear approximation of non-linear strength criterion (Eqn. 25.4). It is found that strength parameters c and ϕ depend upon σ_3 . Thus, they have plotted charts for average values of c (Figure 25.1) and ϕ (Figure 25.2) for a quick assessment. It may be noted that c and ϕ decrease non-linearly with GSI unlike RMR (Table 6.10).

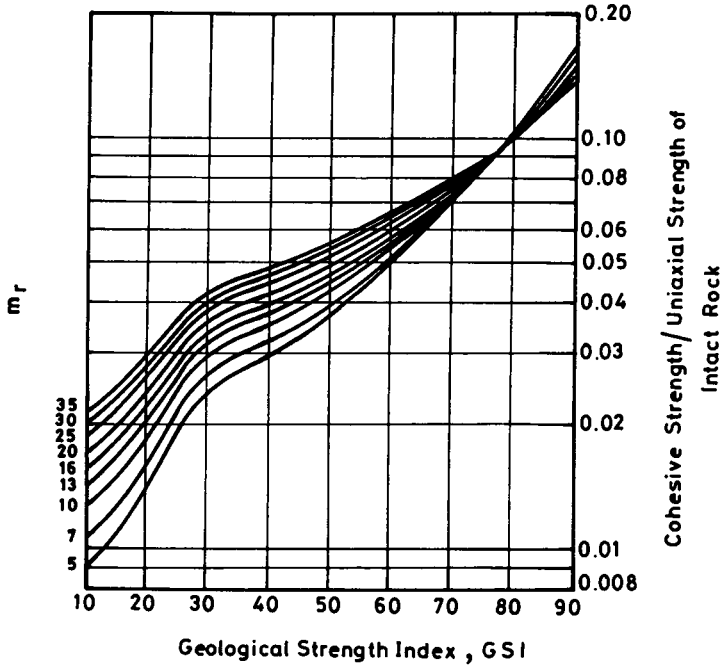

Figure 25.1: Relationship between ratio of cohesive strength to uniaxial compressive strength on intact rock (c/q_c) and GSI for different m_r values (Hoek and Brown, 1997)

The angle of dilatancy of a rock mass after failure is recommended approximately as

$$\begin{aligned}
 \Delta &= (\phi / 4) && \text{for } GSI = 75 \\
 &= (\phi / 8) && \text{for } GSI = 50 \\
 &= 0 && \text{for } GSI \leq 30
 \end{aligned}
 \tag{25.13}$$

The Hoek and Brown's (1997) correlations for 's' are valid for rock slopes and open pit mines only. For tunnels and caverns, there is an enormous strength enhancement (Chapter 13).

Geological strength index (GSI)

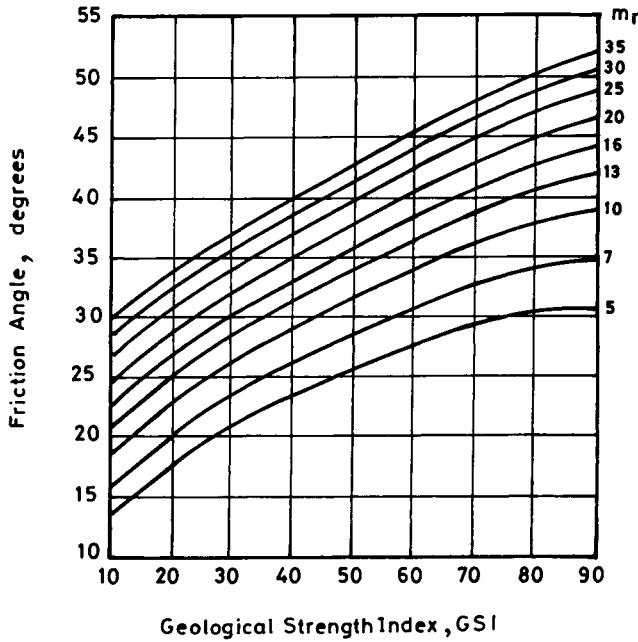

Figure 25.2: Friction angle ϕ for different GSI and m_r values (Hoek and Brown, 1997)

25.4 Modulus of Deformation

The correlation of Serafim and Pereira (1983) has been modified for poor rocks ($q_c < 100$ MPa) after replacing RMR by GSI as follows:

$$E_d = \sqrt{\frac{q_c}{100}} \cdot 10^{(GSI - 10) / 40} \text{ , GPa} \tag{25.14}$$

According to Hoek and Brown (1997), limited field experience tends to validate the correction for strength in weak rock ($q_c < 100$ MPa). However, more field experience is needed for a firm correlation.

25.5 Selection of Rock Parameters for Intact Schistose

In argillaceous or anisotropic rocks (shales, phyllites, schists and gneisses, etc.), the uniaxial compressive strength of rock material q_c depends upon the orientation of the plane of weakness. The geological strength index GSI and RMR take into account the orientation of

joints. To avoid double accounting for joint orientation in both UCS and GSI, it is a common engineering practice to use the upper bound value of q_c and corresponding m_r for rock cores with nearly horizontal planes of weakness for estimating m , s , and E_d for jointed rock masses.

Further, cohesion along joints is needed for wedge analysis or computer modelling. Cohesion along bedding planes or planar continuous joints (longer than 10m) may be negligible. However, cohesion along discontinuous joints (assumed continuous in the wedge analysis) may be the same as cohesion (c) of the rock mass. In fact the cohesion of rock mass is the cohesion of the discontinuous joints. Furthermore, the ratio of c and cohesion of rock material (Figure 25.1) may be of the same order as the area of intact rock bridges per unit area of the discontinuous joints.

TABLE 25.2
RECOMMENDED ENGINEERING PARAMETERS OF ROCK MASS

| S. No. | Rock Mass Parameter | Reference | Recommended Value | Remarks |
|--------|-----------------------------------|---------------------------------------|-----------------------------------|--|
| 1 | n | Eqn. 25.6 | 0.5 | |
| | m | Eqn. 25.7 | 1.1 | |
| | s | Eqn. 25.8 | 6.7×10^{-3} | |
| 2 | c_p | Figure 25.1 | 3.6 MPa | |
| 3 | ϕ_p | -- | 32° | Same as that of rock material |
| 4 | UCS q_{cmass} | $2 c_p \cos\phi_p / (1 - \sin\phi_p)$ | 13 MPa | intercept on σ_1 and σ_3 envelop |
| 5 | UTS q_{tmass} | $0.029 \gamma Q^{0.31}$ | 0.15 MPa | |
| 6 | Angle of dilatancy Δ | $(\phi_p - \phi_r)/2$ | 5° | |
| 7 | ϕ_r | $\phi_p - 10 \geq 14^\circ$ | 22° | |
| 8 | Residual cohesion c_r | Art. 13.8 | 0.1 MPa | |
| 9 | Residual UCS | $2 c_r \cos\phi_r / (1 - \sin\phi_r)$ | 0.3 MPa | |
| 10 | Modulus of deformation E_d | Uniaxial jacking test | 7.5 MPa | Pressure dependency not observed |
| 11 | Poisson's ratio | -- | 0.20 | |
| 12 | Shear modulus | $E_d/10$ | 0.75 MPa | Axis of anisotropy along bedding plane |
| 13 | Suggested model for peak strength | Eqn. 13.12 | $13+2.2(\sigma_1+\sigma_3)/2$ MPa | |
| 14 | Model for residual strength | Mohr's theory | $0.3+1.2 \sigma_3$ MPa | |

25.6 Example

In a major hydroelectric project in dry quartzitic phyllite, the rock mass quality Q is found to be in the range of 6 - 10. The joint roughness number J_r is 1.5 and joint alteration number J_a is 1.0 for critically oriented joints in the underground machine hall. The unit weight of phyllite rock is 2.78 gm/cc. The upper bound strength envelop between σ_1 and σ_3 from triaxial tests gave UCS $q_c = 80$ MPa, $\phi_p = 32^\circ$, $m_r = 5.3$ and $E_r = 116$ MPa when plane of schistosity is either horizontal or vertical. The average UCS for various angle of schistosity is 40 MPa. The GSI is estimated to be about 55 as rock mass is micro-folded and joints are very rough and unweathered. With these values, it is required to suggest the engineering parameters of the rock mass for the machine hall cavity (width 24m and height 47m).

The average rock mass quality is $\sqrt{(6 \times 10)} = 8$ (approx.). Other calculations are presented in Table 25.2 for the undisturbed rock mass. The peak angle of internal friction works out to be 27° from Figure 25.2 and 32° from triaxial tests and 56° from J_r / J_a value. Thus, a value of $\phi_p = 32^\circ$ appears to be realistic. A blast damaged zone of about 2m depth may be assumed in the computer modelling around the cavity with half the values of c_p , $q_{c\text{mass}}$, E_d and G .

It may be emphasized that Table 25.2 suggests parameters for the first iteration only in the computer modelling. The more realistic model and parameters may be back-calculated from the observed displacements of the cavity during upper half-excavation.

References

- Bieniawski, Z.T.(1989). *Engineering Rock Mass Classifications*, John Wiley, p. 251.
- Hoek, E. (1994). Strength of Rock and Rock Masses, *News Journal of ISRM*, **Vol. 2, No.2**, pp. 4-16.
- Hoek, E. (1998). Reliability of Hoek-Brown Estimates of Rock Mass Properties and their Impact on Design, *Int. Jr. Rock Mech. and Min. Sci.*, Pergamon, Technical Note, Under Print.
- Hoek, E. and Brown, E. T. (1997). Practical Estimates of Rock Mass Strength, *Int. Jr. Rock Mech. and Min. Sci.*, Pergamon, **Vol. 34, No. 8**, pp. 1165-1186.
- Palmstrom, A. (1995). Characterising the Strength of Rock Masses for Use in Design of Underground Structures, *Proc. Design and construction of underground structures*, New Delhi, pp. 43-52.
- Serafim, J.L. and Pereira, J. P. (1983). Considerations of the Geomechanics Classification of Bieniawski, *Proc. Int. Symp. Eng. Geol. Underground Construction*, LNEC, Lisbon, **Vol. 1**, pp. 127-140.

EVALUATION OF CRITICAL ROCK PARAMETERS

*“The foundation of all concepts is simple unsophisticated experience.
The personal experience is everything, and logical consistency is not final”*

D.T.Suzuki, Professor of Philosophy, Otani University, Japan

26.1 Introduction

A method of planning is required whereby we have a list of all rock parameters and an understanding of all rock properties and rock mechanics as our fundamental knowledge base. We also need to know precisely what it is we are trying to do: in other words, the method should be objective based. We then need a procedure for identifying the mechanics and rock properties most relevant to our project, within the scope of the objective - and finally we need the ability to select relevant engineering techniques. In this way, we utilize existing knowledge in an optimal way to develop site investigation, design, construction, and monitoring procedures for any project. The Rock Engineering System (RES) will now be presented for selecting site specific critical rock parameters (Hudson, 1992). The sequence of critical rock parameters should be determined and then checked by ratings of various other classifications for confirmation. It may minimize errors of judgements, in this process.

26.2 Critical Parameters

There is some degree of coupling between joints, stress, flow and construction. Thus, this concept of interaction matrix has been developed by Hudson (1992). The parameters in question are placed along the leading diagonal. The twelve leading diagonal terms in case of slopes and underground excavations as considered by Hudson (1992) are given below.

26.2.1 Slopes

Parameters (P_i)

Representing

- | | |
|-----------------------------|--|
| 1. Overall Environment | Geology, climate, seismic risk, etc. |
| 2. Intact Rock Quality | Strong, weak, weathering susceptibility |
| 3. Discontinuity Geometry | Sets, orientations, apertures, roughness |
| 4. Discontinuity Properties | Stiffness, cohesion, friction |
| 5. Rock Mass Properties | Deformability, strength, failure |
| 6. Insitu Rock Stress | Principal stress magnitudes/directions |
| 7. Hydraulic Conditions | Permeability, etc. |
| 8. Slope Orientations, etc. | Dip, dip direction, location |

Evaluation of critical rock parameters

| | |
|---------------------------|-------------------------------------|
| 9. Slope Dimensions | Bench height/width & overall slope |
| 10. Proximate Engineering | Adjacent blasting, etc. |
| 11. Support / Maintenance | Bolts, cables, grouting, etc. |
| 12. Construction | Excavation method, sequencing, etc. |

26.2.2 Underground Excavations

| | |
|----------------------------|--|
| 1. Excavation Dimensions | Excavation size and geometry |
| 2. Rock Support | Rock bolts, concrete liner, etc. |
| 3. Depth of Excavations | Deep or shallow |
| 4. Excavation Methods | Tunnel boring machines, blasting |
| 5. Rock Mass Quality | Poor, fair, good |
| 6. Discontinuity Geometry | Roughness, sets, orientations, distributions, etc. |
| 7. Rock Mass Structure | Intact rock and discontinuities |
| 8. Insitu Rock Stress | Principal stress magnitude and direction |
| 9. Intact Rock Quality | Hard rocks or soft rocks |
| 10. Rock Behavior | Responses of rocks to engineering activities |
| 11. Discontinuity Aperture | Wide or narrow |
| 12. Hydraulic Conditions | Permeabilities, water tables, etc. (after commissioning of hydro projects) |

26.3 Parameter Intensity and Dominance

We know that some parameters will have a greater effect on rock structure system than others and, similarly in turn, the system will have a greater effect on some parameters than others. The approach for quantifying the intensity and dominance of parameters is presented in this section. This is achieved by Hudson (1992) by coding the interaction matrices and studying the interaction intensity and dominance of each parameter.

26.3.1 Generic Matrix Coding

There are five categories into which the mechanism can be classified, ranging from zero to four, corresponding to 'no', 'weak', 'medium', 'strong' and 'critical' interactions respectively. This coding method is viable for any matrix and will serve to demonstrate how the systems approach is developed.

26.3.2 The Cause-Effect Plot

The cause refers to the influence of a parameter on the system and the effect refers to the influence of the system on the parameter. Consider Figure 26.1 which shows the generation of the cause and effect coordinates. The main parameters, P_i , are listed along the leading diagonal with parameter construction as the last box. We intercept the meaning of the rows and the columns of the matrix, as highlighted in Figure 26.1 by the row and the column through P_i . From the construction of the matrix, it is clear that the row passing through P_i represents the influence of P_i on all the other parameters in the system. Conversely, the column through P_i

represents the influence of the other parameters, i.e., the rest of the system on P_i . Once the matrix has been coded approximately, we can find the sum of each row and each column. If now, we think of the influence of P_i on the system, we can term the sum of the row values as the 'cause' and the sum of the column terms as the 'effect', designated as coordinates (C, E). Thus, C represents the way in which P affects the system and E represents the effect that the system has on P. Note that construction itself has (C, E) co-ordinates, representing the post-construction and pre-construction mechanisms respectively.

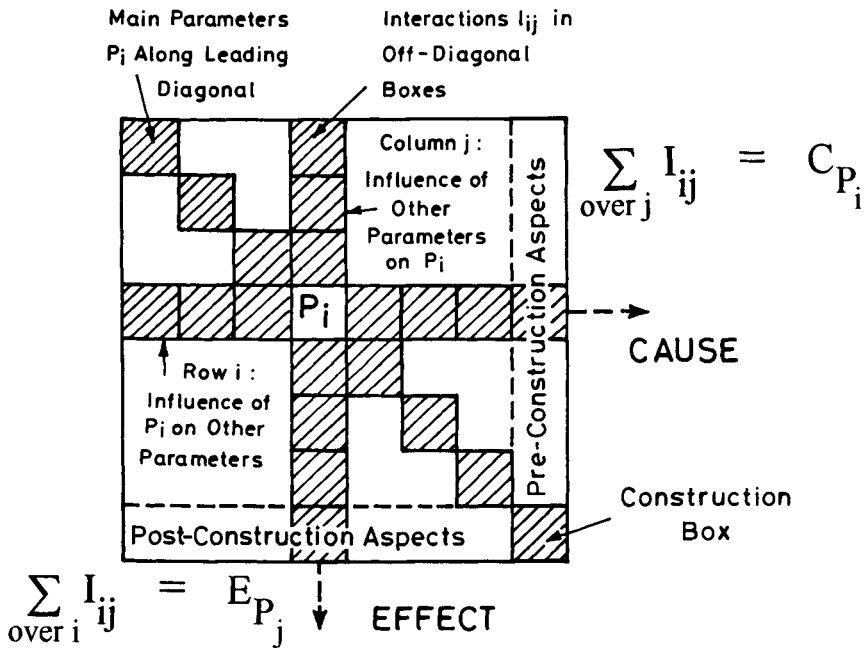

Figure 26.1: Summation of coding values in the row and column through each parameter to establish the cause and effect co-ordinates (Hudson, 1992)

It is important to note that roughly the dual nature of rock parameters is accounted for in this approach. Strength and weakness go together. Poor rock masses are likely to be less brittle, impervious in some cases and have high damping characteristics, unlike hard rocks. It should also be kept in mind that long life of a support system and drainage system is essential in civil engineering projects unlike that in mining projects. In mines interest is mostly in the temporary support system and associated very large deformation rates.

Interpretation of cause-effect plot

The parameter ‘interaction intensity’ and the parameter ‘dominance characteristics’ are shown in Figure 26.2. The two sets of 45° lines in the plot indicate contours of equal value for each of the two characteristics. It is particularly important to note that, whilst the parameter interaction intensity increases from zero to the maximum parameter interaction, the associated maximum possible parameter dominance value rises from zero to a maximum of 50 % parameter interaction intensity and then reduces back to zero at a maximum parameter intensity value. The specific numerical value of the two characteristics are $(C+E)/\sqrt{2}$ and $(C-E)/\sqrt{2}$ as indicated in Figure 26.2.

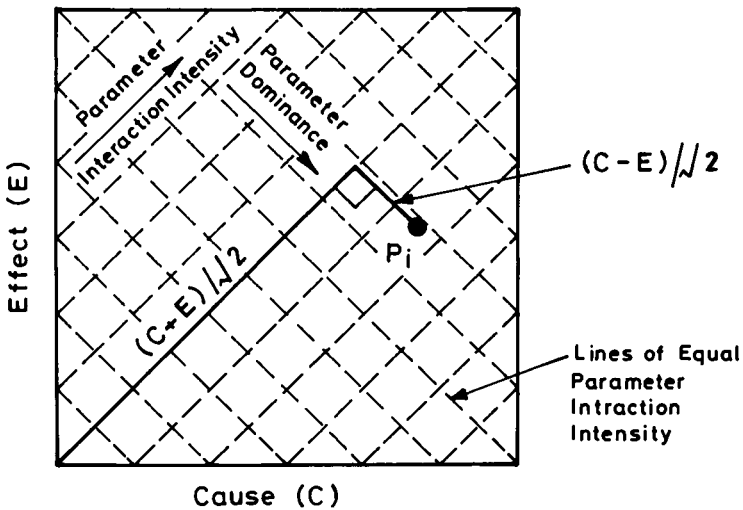

Figure 26.2: Lines of equal parameter interaction intensity and dominance (Hudson, 1992)

26.4 Classification of Rock Mass

There is a need to evolve weightage factors (w_i) for various ‘m’ rock parameters separately for underground openings, slopes, mines and foundations. Hudson (1992) suggested the following rock classification index,

$$\text{Rock Classification Index} = \frac{\sum_{i=1}^m (C_i + E_i) \cdot w_i}{\sum_{i=1}^m (C_i + E_i)} \quad (26.1)$$

where C_i and E_i are cause and effect rating of i^{th} parameter. This rock classification index may be better than RMR or Q which do not take into account the site specific important parameters.

26.5 Example for Studying Parameter Dominance in Underground Excavation for a Coal Mine with Flat Roof

The twelve leading parameters for an underground excavation matrix are enumerated earlier in this chapter. A 12 x 12 matrix keeping these twelve parameters in the leading diagonal has been prepared with numerical coding from 0 to 4 for parameter interaction as shown in Figure 26.3. To explain the coding method here we can highlight some of the extreme values. For example, Box 1, 9 (First row and Ninth column of the matrix in Figure 26.3) is coded as 0. This is the influence of cavern dimensions on intact rock quality. There could be some minor effect in that larger caverns might cause a greater degradation of the intact rock quality but, within the resolution of the coding, we would assign this box a value of 0. On the other hand, Box 2, 10 has been assigned a maximum value of 4, i.e., this is a critical interaction, being the influence of rock support on rock behavior. The whole purpose of rock support is to control the rock behaviour as illustrated in Box 2, 10 and so the coding must be 4.

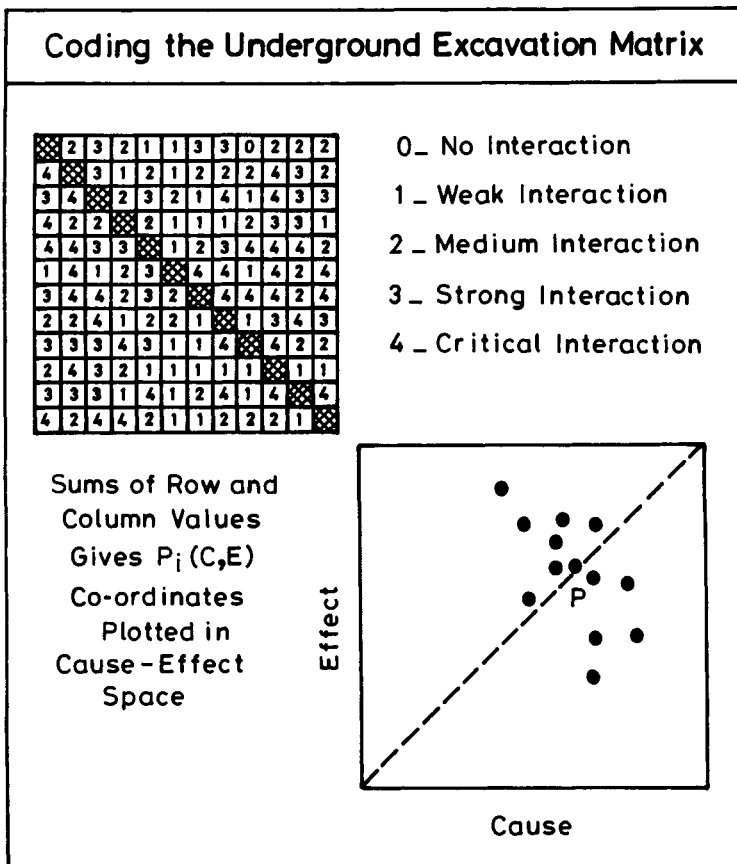

Figure 26.3: Coding values for the generic underground excavations interaction matrix and the associated cause vs effect plot (Hudson, 1992)

Evaluation of critical rock parameters

The associated cause vs effect plot in the lower part of Figure 26.3 shows that the mean interaction intensity is higher and the parameter dominance and subordinancy has been stronger. The cause vs effect plot for underground excavations is clarified in Figure 26.4 with the individual parameter identifiable. In this plot, we find that the most interactive parameter is number 3, i.e. the Depth of Excavation. The least interactive parameter is number 6, the Discontinuity Geometry. The most dominant parameter is number 7, the Rock Mass Structure and the most subordinate (least dominant) parameter is number 10, Rock Material Behaviour, which we would expect because this is conditioned by all the other parameters.

It is emphasized that these are general conclusions about the nature of underground excavations as determined from the generic matrix. If faced with a specific rock type, a specific site and a specific project objective, the generic matrix could be coded accordingly. Naturally this would change the critical parameters.

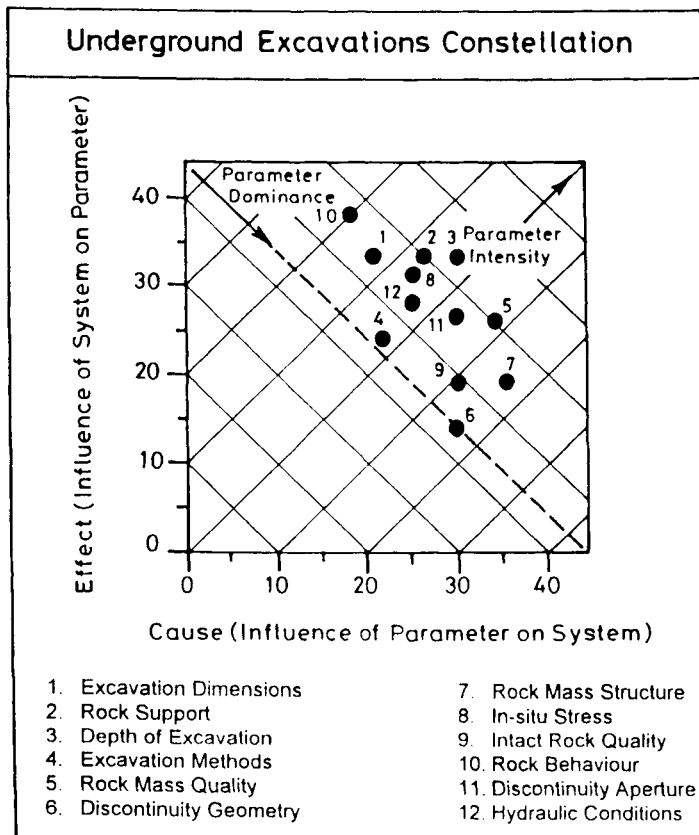

Figure 26.4: Cause vs effect plot for the generic 12x12 underground excavations for the coding values given in Figure 26.3 (Hudson, 1992)

26.6 Relative Importance of Rock Parameters in Major Projects

Hudson and Harrison (1997) have reported histograms of rock parameters for pressure tunnels, large caverns and radioactive waste repositories. The study is based on current practice, recommended practice and over 320 research papers. Tab 26.1 lists their relative importance for the site specific planning, testing and monitoring of projects. Further, there is no need of hoop reinforcement in the concrete lining of water pressure tunnels as PCC may be allowed to crack. The PCC lining has been working since 1980 (Singh et al., 1988) in hydroelectric projects, U.P., India.

TABLE 26.1
RELATIVE IMPORTANCE OF ROCK ENGINEERING PARAMETERS IN ROCK STRUCTURES
(HUDSON AND HARRISON 1997)

| Water Pressure Tunnels in Hydroelectric Projects | Large Underground Caverns | Radioactive Waste Repositories |
|--|-------------------------------|--------------------------------|
| In situ stress | Depth of cavern | In situ stress |
| Discontinuity persistence | Discontinuity orientation | Induced displacement |
| Topographic factors | In situ stress | Thermal aspects |
| Presence of faults/folds | Presence of faults | Discontinuity geometry |
| Location of tunnel | Rock type | Permeability |
| Discontinuity aperture | Discontinuity frequency | Time dependent properties |
| Rock mass geometry | Discontinuity aperture | Elastic modulus |
| Discontinuity fill | Pre-existing water conditions | Compressive strength |
| Tunnel water pressure | Intact rock elastic modulus | Porosity |
| Pre-existing water conditions | Rock mass elastic modulus | Density |

26.7 Application in Entropy Management

Generic Matrix coding can also be used for entropy management of a project. At present effect of unused energy on the entropy is blissfully forgotten. This results in ever increasing entropy or disorderliness, confusion, noise, unhygienic conditions, toxic gases, diseases, etc. Entropy

Evaluation of critical rock parameters

can be decreased effectively by planting a micro-ecosystem around the project, road net work and landslide prone areas, etc. Entropy within a house can be decreased by placing a few pots of indoor plants inside the rooms. Experience the improvement in the living conditions at home and office at no cost.

References

- Hudson, J. A. (1992). *Rock Engineering Systems - Theory and Practice*, Ellis Horwood Limited, U. K, p. 185.
- Hudson, J. A. and Harrison, J. P. (1997). *Engineering Rock Mechanics - An Introduction to the Principles*, Elsevier Science, p. 444.
- Singh, Bhawani, Nayak, G. C., Kumar, R. and Chandra, G. (1988). Design Criteria for Plain Concrete Lining in Power Tunnels, *Jr. Tunnelling & Underground Space Technology*, Pergamon, **Vol. 3, No. 2**, pp. 201-208.

CHAPTER - 27

INSITU STRESSES

“Everything should be made as simple as possible, but not simpler”
Albert Einstein

27.1 Need for Insitu Stress Measurement

The insitu stresses are measured generally by hydro-fracturing method which is economical, faster and simple than other methods. The magnitude and the orientation of insitu stresses may have major influence on planning and design of underground openings in major hydroelectric projects, mining and underground space technology. The orientation of insitu stresses is controlled by major geological structures like fold, faults and intrusions.

27.2 Classification of Geological Conditions and Stress Regimes

Ramsay and Hubber (1988) have shown how type of faults rotates principal insitu stresses (Figure 27.1).

Normal Fault Area (Figure 27.1 a)

These are steeply dipping faults where slip is mostly along dip direction than that along its strike, and the hanging wall is moved downwards. The mechanics of failure suggests that the vertical stress (σ_v) is the major principal stress and the minimum horizontal stress (σ_h) acts along the dip-direction. As such, the order of insitu stresses is given below,

$$\sigma_v > \sigma_H > \sigma_h$$

In a sub-ducting boundary plate, normal faults are found commonly as the downward bending of this plate reduces horizontal stresses along dip direction. However, in the upper boundary plate, thrust faults are seen generally because of the tectonic thrust and thus there is an urgent need for stress analysis of interaction of plate boundaries (Nedoma, 1997).

Thrust Fault Area (Figure 27.1 b)

Thrusts have mild dip with major slip along the dip direction compared to that along its strike, and the hanging wall is moved upwards. The mechanics of brittle failure indicates that the vertical stress in this case should be the minimum principal insitu stress and the horizontal stress along the dip direction is the maximum principal insitu stress. Thus, the order of the insitu stresses in the thrust fault area is as follows:

(a) Normal fault

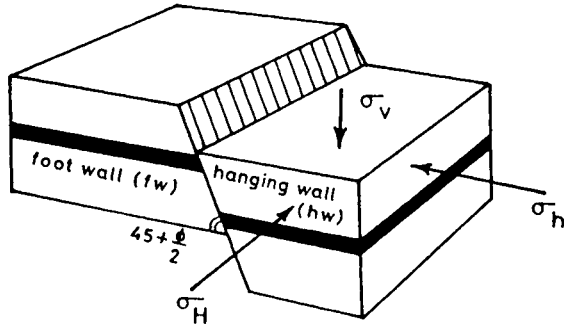

(b) Reverse or thrust fault

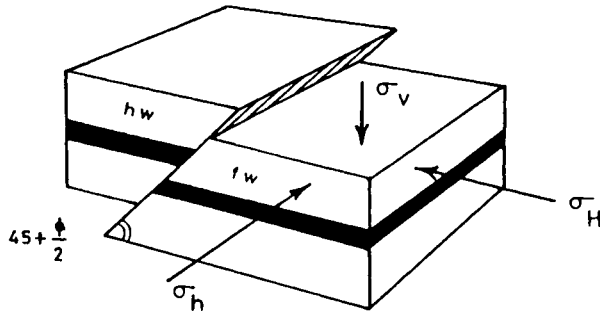

(c) Strike-Slip fault

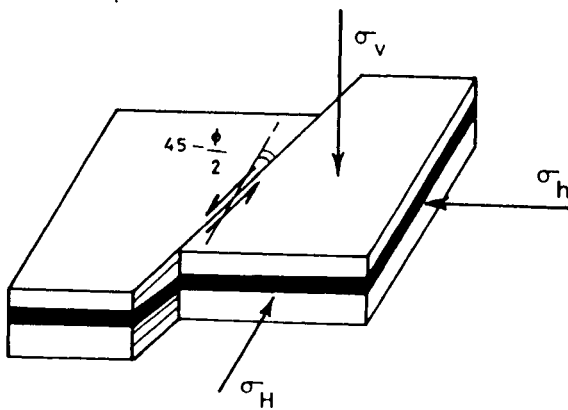

Figure 27.1: Orientation of insitu stresses in various geological conditions (Ramsay and Hubber, 1988)

$$\sigma_H > \sigma_h > \sigma_v$$

It should be noted that the correlations developed in India refer to the geological region of upper boundary plate with frequent thrust and strike-slip faults.

Strike-Slip Fault Area (Figure 27.1 c)

Such faults are steeply oriented and usually vertical. The slip is mostly along the strike than that along the dip direction. In strike - slip fault, the major principal stress and minor principal stress are oriented as shown in Figure 27.1c. Thus, the order of the insitu stresses is given below,

$$\sigma_H > \sigma_v > \sigma_h$$

It may be noted that both magnitude and orientation of horizontal insitu stresses will change with erosion and tectonic movements, specially in hilly regions.

27.3 Variation of Insitu Stresses with Depth

In soils, the insitu horizontal stress is given by the condition of zero lateral strain. Thus, one gets

$$\sigma_{H1} = \sigma_h = v \cdot \sigma_v / (1 - v) \tag{27.1}$$

where v is Poisson's ratio of soil mass.

In the case of rock masses, there are significant horizontal stresses even near ground surface due to the non-uniform cooling of the earth crust. Moreover, the tectonics stresses also affect the insitu stresses significantly. Hoek and Brown (1980) analyzed world - wide data on measured insitu stresses. They found that the vertical stress is approximately equal to the overburden stresses.

The regional stresses vary in a wide range as follows (depth $z < 2000\text{m}$):

$$\sigma_{H1} < 40 + 0.5 \sigma_v \quad \text{MPa} \tag{27.2}$$

$$\sigma_h > 2.7 + 0.5 \sigma_v \quad \text{MPa} \tag{27.3}$$

$$\sigma_v \cong \gamma z \tag{27.4}$$

where γ is unit weight of the rock mass ($\gamma = 2.7 \text{ g/cc}$ or T/m^3) and z is depth of the point under reference below the ground surface.

In situ stresses

According to McCutchin (1982), the tectonic stress component (at ground level) depends upon the modulus of deformation of the rock mass as given below,

$$\sigma_{dv} = 7 \gamma E_d + \sigma_v (0.25 + 0.007 E_d), \quad T/m^2 \quad (27.5)$$

where E_d is modulus of deformation in GPa.

The regional horizontal insitu stresses are relaxed in steep mountainous regions. These stresses are relaxed more with decreasing distance from the slope face. Thus, the gradient of the horizontal stress with depth (or vertical stress) may be more in steeply inclined mountainous terrain compared to that in the plane terrain.

Stephansson (1993) has reported the following trend for insitu horizontal stresses at shallow depth ($z < 1000m$) from hydro-fracturing tests

$$\sigma_H = 2.8 + 1.48 \sigma_v \quad \text{MPa} \quad (27.6)$$

$$\sigma_h = 2.2 + 0.89 \sigma_v \quad \text{MPa} \quad (27.7)$$

$$\sigma_v = \gamma z$$

He also showed that the measured insitu stresses depend significantly on the method of testing.

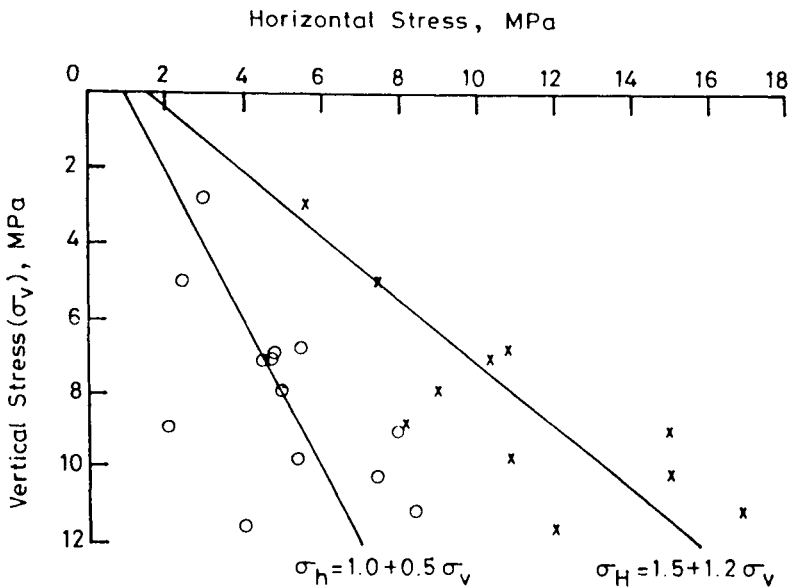

Figure 27.2: Variation of insitu stresses near Himalayan region (Sengupta, 1998)

Sengupta (1998) performed a large number of hydro-fracturing tests within weak rocks in the Himalayan region. Figure 27.2 shows his test data. It is heartening to see a good correlation between σ_{H} and σ_{V} . The correlation between σ_{H} and σ_{V} is not good due perhaps to mountainous terrain. Thus, it is inferred that for $z < 400$ metres,

$$\sigma_{\text{H}} = 1.5 + 1.2 \sigma_{\text{V}} \quad \text{MPa} \quad (27.8)$$

$$\sigma_{\text{h}} = 1.0 + 0.5 \sigma_{\text{V}} \quad \text{MPa} \quad (27.9)$$

It appears that Stephansson's correlations (Eqns. 27.6 and 27.7) predict on a higher side, whereas Sengupta's correlations predicts on the lower side of the actual insitu stresses. Perhaps in steeply inclined mountainous terrain, Sengupta's correlations (Eqns. 27.8 and 27.9) may be applicable in the stress region ($\sigma_{\text{H}} > \sigma_{\text{V}} > \sigma_{\text{h}}$) as the insitu horizontal stresses are likely to be relaxed significantly.

In other stress regimes, separate correlations need to be developed. Needless to mention that in major projects, statistically significant number of hydrofracturing tests should be conducted to know how rotation of insitu stresses is taking place along folds and across faults at a site. This may help in mine planning locally as well as in the design of a support system or selection of support strategy in major underground projects.

"A scientist should also be a good businessman in the future"

References

- Hoek, E. and Brown, E. T. (1980). *Underground Excavations in Rock*, Institution of Mining and Metallurgy, London.
- McCutchin, W. R. (1982). Some Elements of a Theory of Insitu Stresses, *Int. Jr. Rock Mech. and Min. Sci. & Geomech. Abstr.*, Pergamon, **Vol. 19**, pp. 201-203.
- Nedoma, J. (1997). Part I - Geodynamic Analysis of the Himalayas and Part II - Geodynamic Analysis, *Institute of Computer Science, Academy of Sciences of the Czech Republic*, **Technical Report No. 721, September**, p.44.
- Ramsay, G. and Hubber, M. I. (1988). The Techniques of Modern Structural Geology, Vol. 2, Folds and Fractures, *Academic Press*, pp. 564-566.
- Rummel, F., Erdmann, G. M. and Baumgartner, J. (1986). Stress Constraints and Hydrofracturing Stress Data for the Continental Crust, *PAGEOPH*, **Vol. 124, No. 4/5**, pp. 875-895.
- Sengupta, S. (1998). Influence of Geological Structures on Insitu Stresses, *Ph.D. Thesis, Department of Civil Engineering, Indian Institute of Technology, New Delhi*, p. 275.
- Stephansson, O. (1993). Rock Stress in the Fennoscandian Shield, *Comprehensive Rock Engineering*, Pergamon, **Vol. 3, Chap. 17**, pp.445-459.

AUTHOR INDEX

- Abad et al. (1984), 93
Abdullatif and Cruden (1983), 209
Anbalagan (1992), 184
Anbalagan et al. (1992), 176
- Barton (1982), 150
Barton (1987), 234
Barton (1991), 89
Barton (1990), 111
Barton (1993), 150
Barton and Bandis (1990), 155
Barton and Choubey (1977), 148
Barton et al. (1980), 128, 150
Barton et al. (1974), 50, 68
Bateman (1967), 217
Bazant et al. (1993), 129, 138
Bhasin and Grimstad (1996), 59, 75
Bhasin et al. (1995), 5
Bieniawski (1973), 34
Bieniawski (1976), 44, 242
Bieniawski (1978), 42, 237
Bieniawski (1979), 171
Bieniawski (1984), 34
Bickel and Kuesel (1983), 215
Bray (1967), 10
Brekke (1968), 29
Brekke and Howard (1972), 230
- Cameron - Clarke and Budavari (1981), 93
Cecil (1970), 28
Chakraborty, Jethwa and Dhar (1997), 211
Chauhan (1982), 120
Cording and Deere (1972), 23
Cording et al. (1971), 128
- Daemen (1975), 99
Deere (1968), 17
Deere et al. (1969), 11, 99
- Fairhurst and Cook (1966), 15
Fairhurst and Singh (1974), 131
Franklin (1970), 109
Franklin (1974), 209
- Franklin (1993), 210
- Gamble (1971), 15
Gill (1980), 203
Goel (1994), 99
Goel and Jethwa (1991), 44
Goel et al. (1995), 54, 80
Goel et al. (1995a), 92
Goel et al. (1995b), 56, 93
Goel et al. (1996), 99
Goodman (1970), 233
Goodman, Heuze and Ohnishi (1972), 233
Grimstad and Barton (1993), 69, 83
Grimstad and Bhasin (1995), 237
Grimstad and Bhasin (1996), 140
Gupta and Anbalagan (1995), 184
- Hoek (1994), 138, 242
Hoek and Bray (1981), 164
Hoek and Brown (1980), 11, 93, 260
Hoek and Brown (1997), 2, 42, 242
Hoek and Brown (1988), 108
Hoek et al. (1992), 108
Houlsby (1977), 220
Hudson (1992), 2, 250
- ISRM (1978), 34, 150
- Jaeger and Cook (1969), 155
Jethwa (1981), 99
Jethwa and Dhar (1996), 50
John (1971), 12
Jumikis (1983), 219
- Kaiser et al. (1986), 80
Knill (1969), 220
Kumar (1988), 89
- Lama and Vutukuri (1978), 94
Lang (1971), 6
Laubscher (1984), 238
Lauffer (1988), 40
Lugeon (1933), 221

- Matula and Holzer (1978), 108
McCutchin (1982), 261
Mehrotra (1992), 2, 43,201
Mehrotra (1993), 158
Mehrotra (1996), 143
Moreno (1980), 93
Murrell (1963), 138
- Nedoma (1997), 258
Nast (1955), 217
- Palmstrom (1982, 1985, 1986), 19
Palmstrom (1995), 108, 143, 245
Palmstrom (1996), 19
Park et al. (1997), 129
Peck, Hansen and Thorburn (1974), 200
Piteau (1970), 109
- Ramamurthy (1993), 139
Ramsay and Hubber (1988), 258
Ranjan et al. (1982), 205
Romana (1985), 171, 176
Rose (1982), 27
Roy (1993), 139
Rutledge and Preston (1978), 93
- Sakurai (1994), 136
Samadhiya (1998), 128, 133
Sengupta (1998), 262
- Sen and Eissa (1991, 1992), 19
Serafim and Pereira (1983), 42, 247
Singh et al. (1987), 209
Singh et al. (1992), 50, 75
Singh et al. (1995), 31, 128
Singh et al. (1998), 129
Singh (1973), 156, 200
Singh (1991), 201
Singh, Fairhurst and Christiano (1973), 131
Sinha (1989), 26
Sinha (1993), 234
Stephansson (1993), 261
- Terzaghi (1946), 25
Thakur (1995), 133
Tsoutrelis et al. (1990), 108
Unal (1983), 43
- Valdiya (1980), 191
Verman (1993), 43
- Wagner (1987), 111
Wang and Kemeny (1995), 142
Wawersik (1968), 12
Wickham et al. (1972), 99
Wilbur (1982), 214

SUBJECT INDEX

- Active stress, 68
- Allowable bearing pressure, 43,201
- Anchor
 - length, 129
- Angle
 - dilation, 246
 - internal friction, 40, 68, 110, 154
 - peak friction, 154
 - residual friction, 154
- Basic rock mass rating, 36
- Blasting, 210
- Block size, 68
- Caverns, 128
- Cause-effect plot, 251
- Class I and II Rocks, 12
- Classification
 - job condition, 121
 - bearing pressure, 202
 - management condition, 121
 - rock material, 12
 - rock slopes, 164
- Coefficient
 - volumetric expansion, 105
- Cohesion, 40
- Condition of discontinuities, 36
- Correction factor
 - time after excavation, 75
 - tunnel closure, 75, 97
 - tunnel depth, 75
- Deformability, 237
- Drillability, 213
- Drilling
 - condition, 214
 - speed, 216
- Discontinuities
 - opening, 133
- Elastic modulus, 89
- Elastic uniform compression, 205
- Equivalent dimension, 80
- Excavation, 207, 210, 212
- Excavation support ratio (ESR), 80
- Failure criterion, 138
 - new, 141
- Field Data, 70
- Flowing ground condition, 48
- Formation, 215
- Fracture, 214
- Geological strength index (GSI), 242
- Geomechanics classification, 34
- Geotechnical chart, 72
- Gouge, 230
 - material, 230
- Ground conditions, 48
- Ground reaction curve, 103
- Grout, 222
 - liquid, 224
 - pressure, 227
 - special, 224
 - suspension, 223
- Grouting
 - consolidation, 223
 - parameter, 226
- Half-tunnel, 239
- Hard rock mass
 - support pressure, 235
- Hardness, 213
- Homogeneity, 10
- Horizontal stress, 258
- Inhomogeneity, 10
- In situ stresses, 258
- Joint
 - alteration, 109
 - alteration number, 63
 - condition, 109
 - orientation, 69
 - roughness, 109
 - roughness number, 63

- set number, 62
- shear strength, 155
- Joint water reduction factor, 63
- Joint wall
 - compressive strength, 148
 - roughness, 148
- Jointing parameter, 109, 245
- Landslide hazard zonation (LHZ), 184
- Lugeon test, 221
- Lugeon value, 221
- Management, 2
- Modified slope mass rating, 176
- Modulus of Deformation, 41, 247
 - rock mass, 87
- Modulus of elasticity
 - rock mass, 87
 - rock material, 88
- Modulus reduction factor, 41
- Mohr-Coulomb Criteria, 245
- New austrian tunnelling method (NATM), 29, 84
- Nomograms, 97
- Normal Fault, 258
- Norwegian method of tunnelling (NMT), 29, 86
- Orientation of discontinuities, 37
- Parameter
 - dominance, 251
 - intensity, 251
- Permeability, 219
- Philosophy, 2
- Porosity, 219
- Q-system, 62
- Ravelling, 48
- Relative relief, 189
- Rippability, 207
- Rippability classification index, 209
- Ripping, 208
- Rock engineering system (RES), 250
- Rock bolt
 - length, 128, 129
 - spacing, 128
- Rock burst, 48
- Rock condition rating (RCR), 38, 92
- Rock load factor, 25
- Rock mass
 - failure envelope, 158
- Rock mass index (RMI), 108
- Rock mass number (N), 54, 92
- Rock mass quality (Q), 50
- Rock mass rating (RMR), 34
- Rock mass strength
 - dynamic, 144
- Rock mass strength enhancement, 142
- Rock material, 10
- Rock quality designation (RQD), 17, 62
- RQD, 17, 62
- Running condition, 48
- Scale effect, 111
- Self-supporting tunnel, 47, 144, 239
- SFRS, 70
- Shear strength of rock mass, 43
- Shear zone, 5
- Slake durability classification, 16
- Slope mass rating, 171
- Slope Stability Classes, 175
- Spacing of discontinuities, 35
- Squeezing ground condition, 48
- Squeezing rocks, 48
- stand-up time, 39
- Strength envelopes, 143
- Stress reduction factor, 63
- Strike-slip fault, 260
- Support pressure, 27, 43, 72
 - horizontal/wall, 72
 - non-squeezing, 96
 - short-term, 75
 - squeezing, 96
 - ultimate, 72
 - vertical/roof, 72
- Support
 - design, 81
- Support stiffness, 102
- Swelling, 48
- Tensile strength, 143
- Texture, 214

Subject index

Thrust Fault, 258
Tunnel closure, 56
 non-squeezing, 102
 squeezing, 102

Tunnelling conditions, 48

UCS, 237
Uncertainties, 2
Underground openings, 207
Uniaxial compression, 13
Unsupported span, 80
UTS, 238

Vertical stress, 258
Volumetric joint count, 19

Wall factor, 74
Wedge failure, 176
Weightage factor, 253
Weighted joint density, 20