

STEP BY STEP GUIDE BOOK ON

Home Wiring

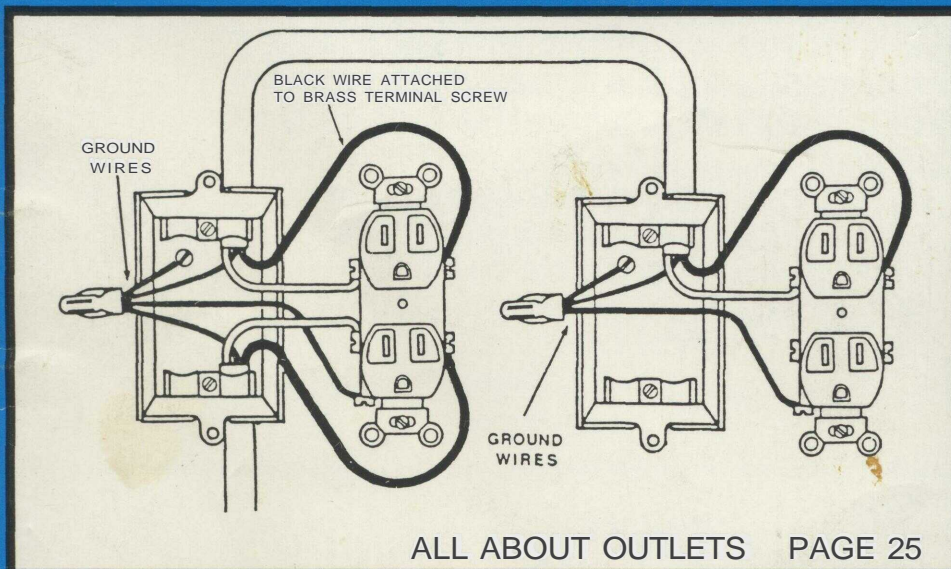

LOADED WITH
SIMPLE, EASY TO
FOLLOW WIRING
DIAGRAMS

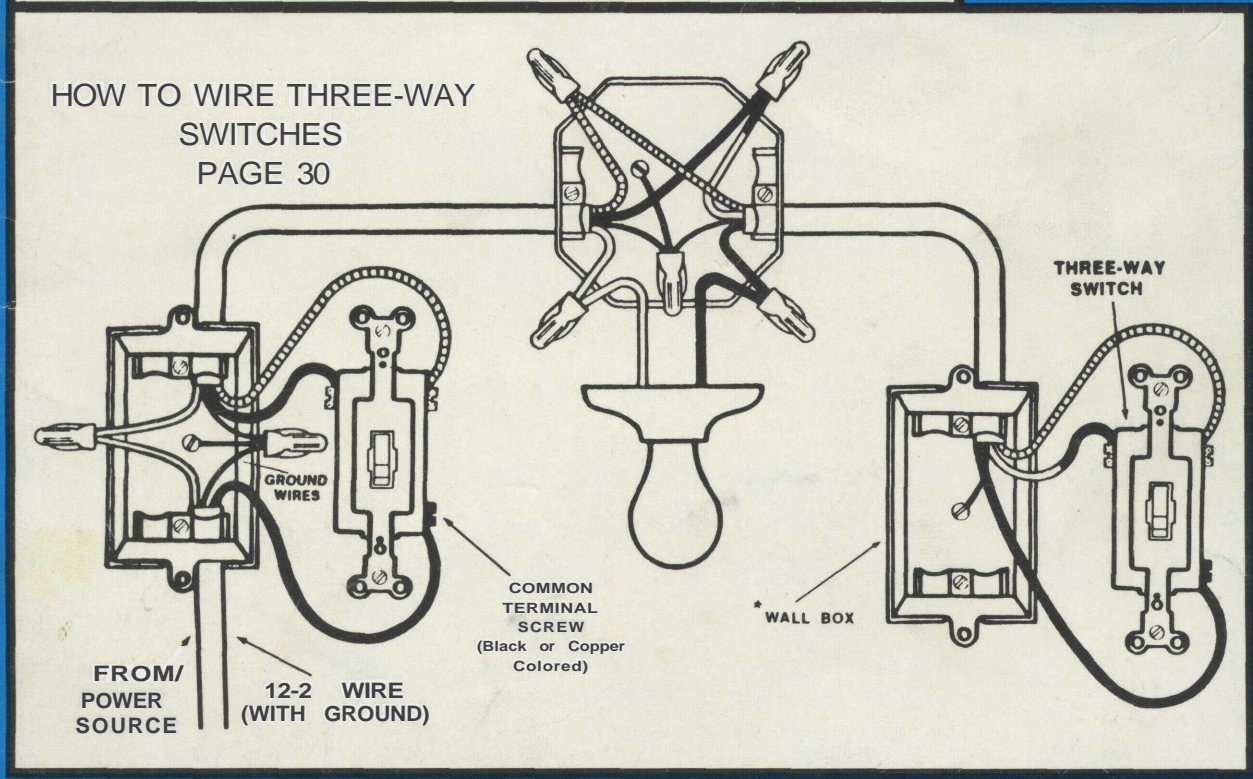

TABLE OF CONTENTS

	PAGE
HOW THE HOME ELECTRICAL SYSTEM WORKS	2, 3, 28
HOW TO TURN OFF MAIN POWER SUPPLY	4
THE THREE WAYS TO GET POWER TO YOUR NEW WIRING JOB	5
HOW THE GROUND WIRE WORKS IN PLASTIC BOXES.....	6, 7
ALL ABOUT ELECTRIC WIRE	8, 9
HOW TO USE WIRENUTS AND SCREW TERMINALS	10
HOW TO INSTALL WIRING IN NEW WALLS AND PETITIONS.....	11
THE MOST COMMON MEASUREMENTS FOR OUTLETS AND SWITCHES .	12
ALL ABOUT THE GROUND WIRE	13
HOW TO WIRE ELECTRIC DRYERS AND RANGES	14,15
WATTS USED BY VARIOUS ELECTRICAL ITEMS.....	16
HOW TO FMD THE CAUSE OF A SHORT CIRCUIT.....	17
HOW TO FIX FLOURESCENT LIGHTS.....	18
HOW TO WIRE BOXES, FIXTURES AND SWITCHES	19
COLOR CODING OF WIRES, AND SCREW TERMINALS	20
ELECTRICAL SYMBOLS ALSO ALL ABOUT SWITCHES	21
HOW TO ADD NEW OUTLETS TO EXISTING ONES.....	22, 23
ALL ABOUT OUTLETS	24 to 29
ALL ABOUT 3 WAY SWITCHES.....	30 to 37
ALL ABOUT SINGLE POLE SWITCHES	38 to 43
ALL ABOUT 4 WAY SWITCHES	44
HOW TO WIRE OUTLET AND LIGHT WITH PULL CHAIN	45
HOW TO WIRE OUTLET - SWITCH AND LIGHT.....	46, 47
ELECTRICAL TERMS.....	48

IMPORTANT

ALL OF THE ILLUSTRATIONS IN THIS BOOK SHOW TYPICAL WIRING METHODS, ACTUAL INSTALLATIONS MUST BE ADAPTED TO INDIVIDUAL REQUIREMENTS, SO FOLLOW NATIONAL, STATE, AND LOCAL ELECTRICAL CODES.

STEP BY STEP GUIDE BOOK CO. HAS MADE EVERY EFFORT TO ENSURE ACCURACY AND RELIABILITY OF THE INFORMATION INSTRUCTIONS, AND DIRECTIONS IN THIS BOOK; HOWEVER, IT IS IN NO WAY TO BE CONSTRUED AS A GUARANTEE.





STEP BY STEP GUIDE BOOK CO. IS NOT LIABLE IN CASE OF MISINTERPRETATIONS OF THE DIRECTIONS, HUMAN ERROR OR TYPOGRAPHICAL MISTAKES.

Copyright © 1982
Revised 1989
Revised 1990
Revised 1994
Step By Step Guide
Book Co.

Author: Ray McReynolds

**IF YOU CANT FIND OUR BOOKS IN YOUR AREA,
CALL US ON OUR TOLL FREE PHONE NUMBER
FOR INFOMATION ON THEM. 1-800-678-1500 OR
WRITE TO:**

**Step-By-Step Guide Book Co.
P.O. Box 70865
Salt Lake City, Utah 84170**

WIRING COLOR GUIDE		
	WHITE WIRE	<i>neutral</i>
	BLACK WIRE	<i>tor</i>
	RED WIRE	<i>hot</i>
	BARE WIRE	<i>ground wire</i>

How the Home Electrical System Works

WIRE NUT GUIDE	
	USE RED WIRE NUTS WHERE WIRE NUTS ARE USED ON THIS PAGE INCLUDING GROUND WIRES

Color coding of wire

- The black wire is **HOT**
- The white wire is **NEUTRAL**

Etch this wiring rule in your memory and keep it there. NEVER CONNECT THE BLACK (HOT) WIRE TO THE WHITE (NEUTRAL) WIRE. (Exception: see page 20)

Connect the black wire to the brass-colored terminal on switches, receptacles, sockets, fuse boxes, and to the black wires on pull chain fixtures. The white (neutral or ground wire—also called the "continuous wire") is grounded at the electric service switch. Connect it to the silver or light-colored terminal of all receptacles, etc., and to the white wire on all lighting fixtures. Again—never hook to the hot wire!

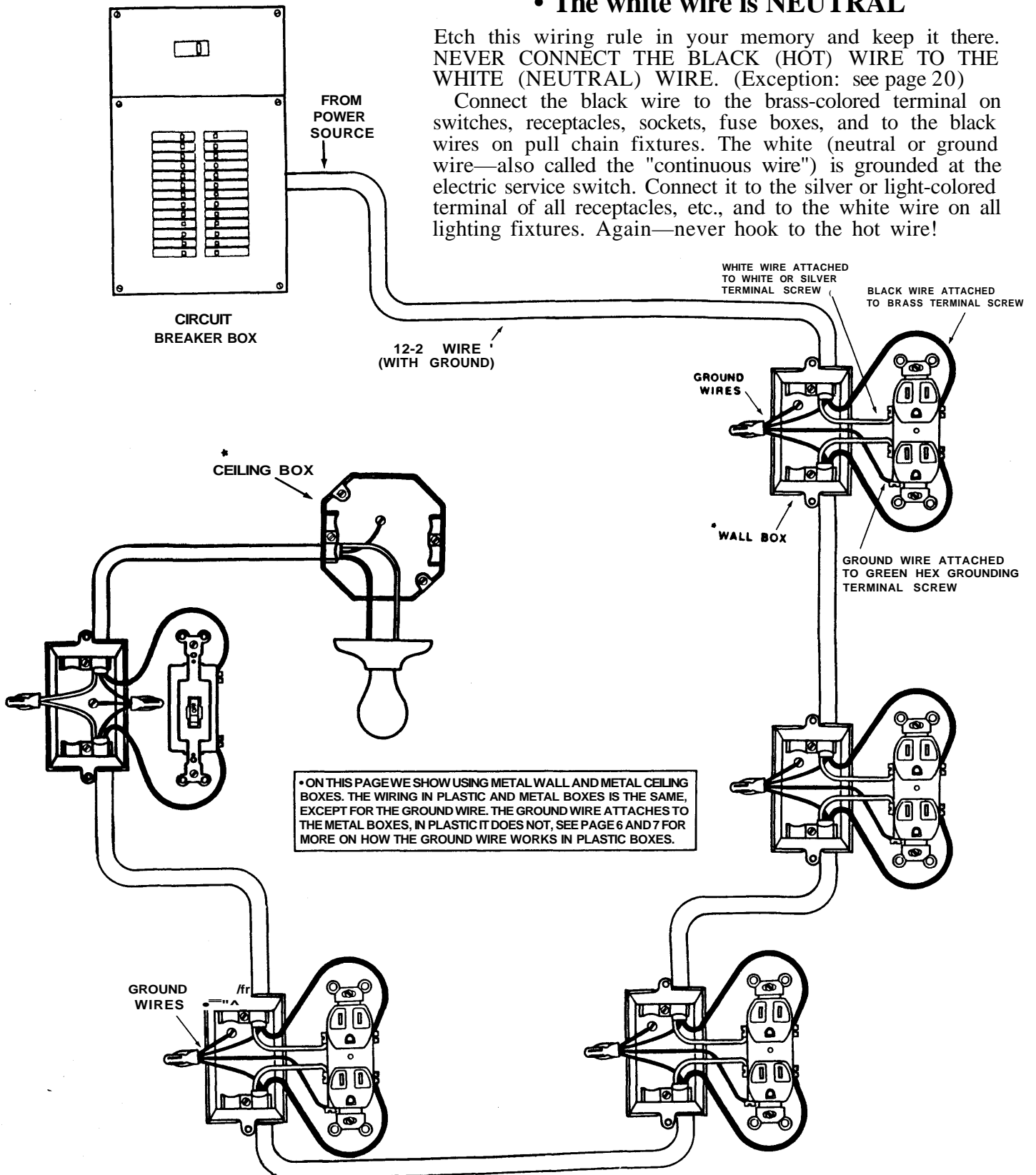

• ON THIS PAGE WE SHOW USING METAL WALL AND METAL CEILING BOXES. THE WIRING IN PLASTIC AND METAL BOXES IS THE SAME, EXCEPT FOR THE GROUND WIRE. THE GROUND WIRE ATTACHES TO THE METAL BOXES, IN PLASTIC IT DOES NOT, SEE PAGE 6 AND 7 FOR MORE ON HOW THE GROUND WIRE WORKS IN PLASTIC BOXES.

WIRE NUT GUIDE	
A MINI NUT	USE RED WIRE NUTS WHERE WIRE NUTS ARE USED ON THIS PAGE INCLUDING GROUND WIRES

WIRING COLOR GUIDE	
	WHITE WIRE NEUTRAL
	BLACK WIRE HOT
	RED WIRE HOT
	BARE WIRE GROUND WIRE

How the Home Electrical System Works

THE PICTURE BELOW SHOWS HOW THE POWER SUPPLY COMES OUT OF THE BREAKER BOX SUPPLYING POWER TO THE OUTLETS AND HOW TO CHANGE DIRECTION OF THE WIRE WITH THE USE OF A JUNCTION BOX.

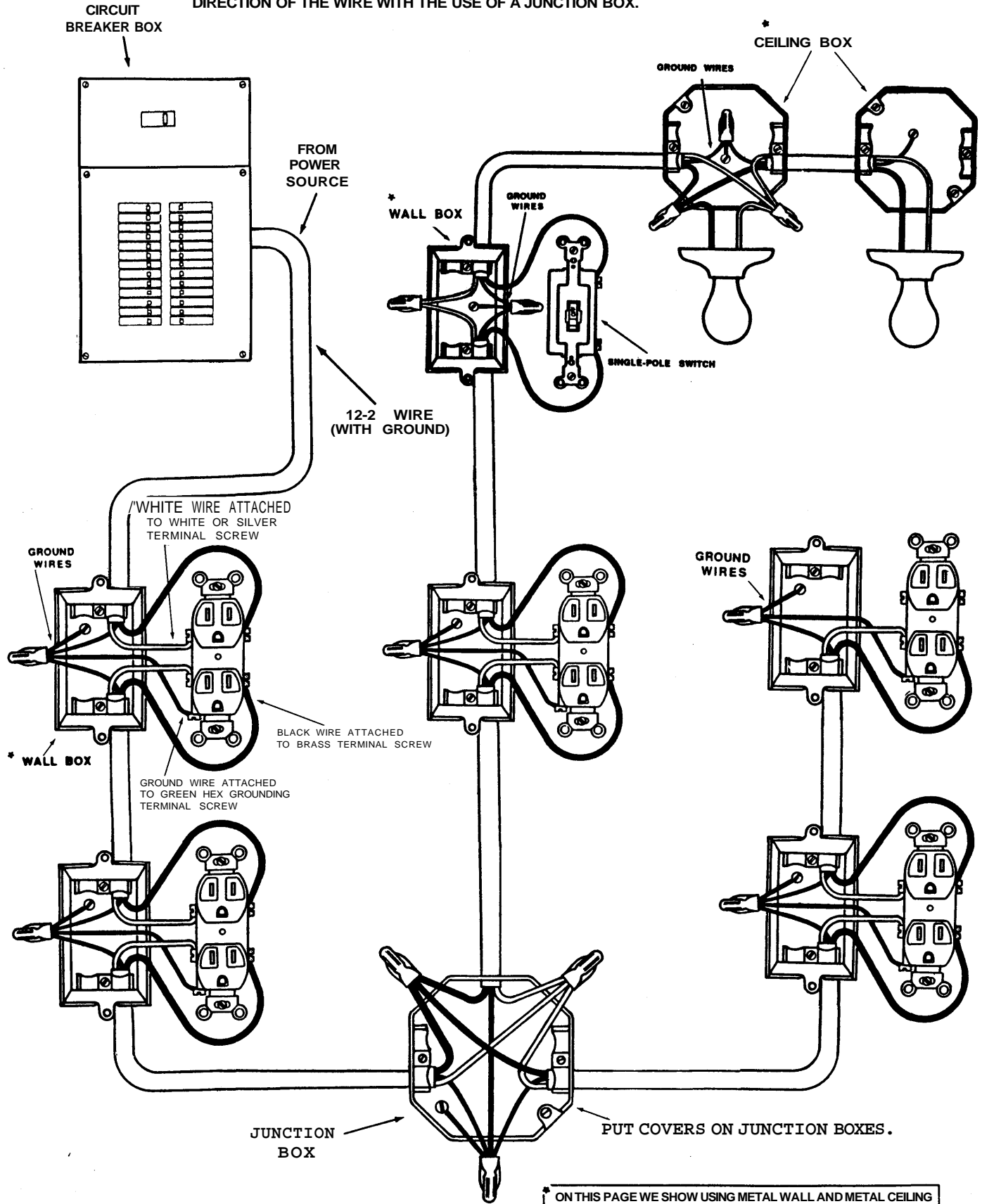

ON THIS PAGE WE SHOW USING METAL WALL AND METAL CEILING BOXES. THE WIRING IN PLASTIC AND METAL BOXES IS THE SAME, EXCEPT FOR THE GROUND WIRE. THE GROUND WIRE ATTACHES TO THE METAL BOXES, IN PLASTIC IT DOES NOT, SEE PAGE 6 AND 7 FOR MORE ON HOW THE GROUND WIRE WORKS IN PLASTIC BOXES.

How to Turn off Main Power Supply

Before starting any work, you must disconnect (or "kill") the circuit you'll be working on at its source in the service panel. If your circuits are protected by fuses, removing the appropriate fuse disconnects the circuit from incoming service. In a service panel equipped with circuit breakers, you can disconnect a circuit by switching its breaker to the OFF position.

To make sure you disconnect the correct circuit, turn on a light that's connected to the circuit before you remove the fuse or turn off the circuit breaker. The light will go out when you've removed the correct fuse or turned off the correct breaker.

If you have any doubt about which fuse or breaker protects which circuit, shut off all current coming into your home at the main disconnect.

While you're at your service panel, spend another moment to prevent a possible disaster. Tape a note on the panel explaining what you're doing so no one will come along and replace the fuse or reset the circuit breaker while you're working on the wiring. Then either carry the fuse with you in your pocket or tape the circuit breaker in its OFF position.

With the electricity turned off, you can work in complete safety. Still, it's a good idea to keep a few additional safety precautions in mind.

Remember that water and electricity don't mix. Never work on wiring, fixtures, switches, or appliances when you're wet or standing on a damp spot. Lay down dry boards to stand on if the floor or ground is wet.

Chart Shows Color Coding of Wires and Terminal Screws		
Color of Wire	Color of Terminal Screw	Hot — Neutral or Grounding Wire
White	Silver or White	Neutral Wire
Black	Brass	Hot Wire
Red	Brass	Hot Wire
Green	Green	Grounding Wire
Bare Wire	Green	Grounding Wire

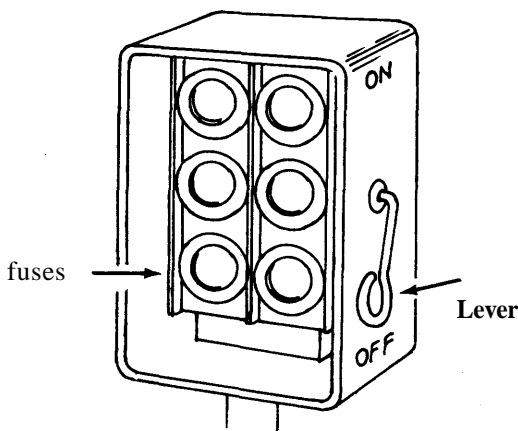
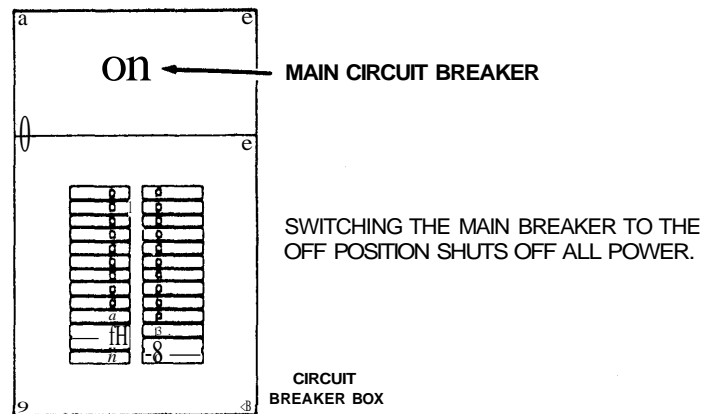

Lever disconnect. An external handle controls contact with two main fuses in the cabinet. When you pull the handle to the OFF position, you shut off the main power supply.

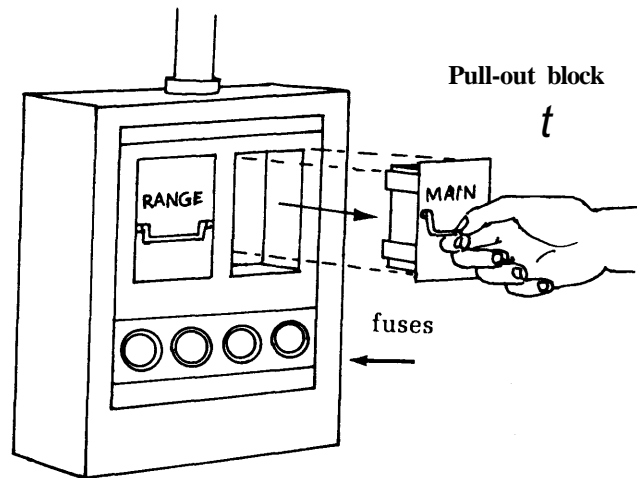

Pull-out block. The main cartridge fuses are mounted on one or two nonmetallic pull-out blocks. By pulling firmly on the hand-grips, you can remove the blocks from the cabinet and disconnect all power.

THE THREE WAYS TO GET POWER TO YOUR NEW WIRING JOB

Important To Your Safety

ALWAYS SHUT OFF POWER TO THE CIRCUIT YOU WILL BE WORKING ON, OR THE ENTIRE HOUSE IF YOU ARE NOT SURE WHICH FUSE OR BREAKER CONTROLS THE CIRCUIT.

NOTE:
YOU MUST NOT EXCEED THE NUMBER OF POLES OR SPACES FOR WHICH THE PANEL BOARD IS APPROVED REGARDLESS OF WHETHER THERE IS ROOM OR SPACE IN THE PANEL

1. FIRST YOU LOCATE THE CIRCUIT BREAKER BOX THAT CONTROLS THE POWER COMING INTO THE HOUSE, SEE IF THERE IS ANY ROOM LEFT FOR THE CIRCUIT BREAKERS YOU NEED. IF THERE IS GET THE MAKE AND MODEL OFF OF IT AND GO TO YOUR LOCAL ELECT. PARTS STORE AND PURCHASE THE BREAKERS YOU NEED. (SEE PICTURE #1)

PICTURE #1

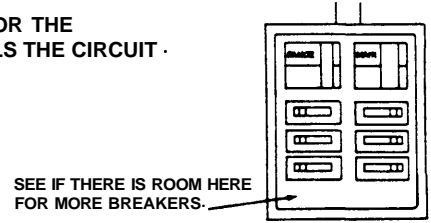

2. SECOND, IF THERE IS NO ROOM LEFT IN CIRCUIT BREAKER BOX, CHECK MAKE AND MODEL AS IN #1 ABOVE AND SEE IF THEY HAVE A NARROWER CIRCUIT BREAKER THAT WILL FIT YOUR PARTICULAR BREAKER BOX. MOST CIRCUIT BREAKERS ARE 1" THICK BUT THEY MAKE SOME BREAKERS 1/2" THICK. TAKE OUT ONE THAT IS 1" THICK AND INSTALL 2 - 1/2" THICK ONES. (SEE PICTURE #2)

PICTURE #2



IF THIS PANEL IS FULL, TRY AND GET NARROW BREAKERS.

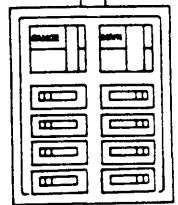

ON NUMBER 3 CHECK WITH YOUR LOCAL ELECTRICAL INSPECTOR TO SEE IF IT IS PERMITTED.

3. THIRD, IF WAYS #1 AND #2 DO NOT WORK FOR YOU, GO TO YOUR LOCAL ELECT. PARTS STORE AND GET A SUB-PANEL THAT WILL WORK WITH THE MULTI BREAKER YOU HAVE - BRAND ETC. GET ONE THAT HAS AS MANY NEW BREAKERS AS YOU NEED FOR YOUR JOB. (SEE PICTURE #3)

PICTURE #3

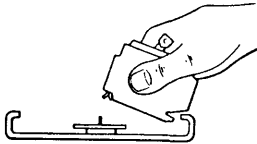

THIS SHOWS A BREAKER BEING ATTACHED TO THE BREAKER BOX.

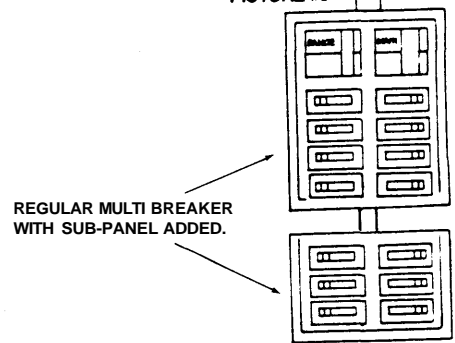

REGULAR MULTI BREAKER WITH SUB-PANEL ADDED.

Important

IF USING #14-2 WIRE WITH GROUND, USE A 15 AMP BREAKER TO PROTECT THE LINE.

IF USING #12-2 WIRE WITH GROUND, USE A 20 AMP BREAKER TO PROTECT THE LINE.

All About Circuit Breakers

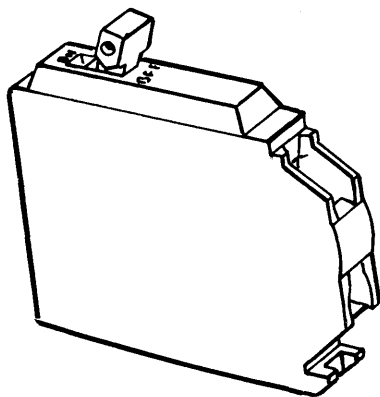

Single Circuit Breaker

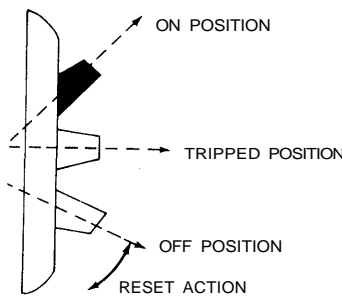

POSITIONS OF THE CIRCUIT BREAKER HANDLE

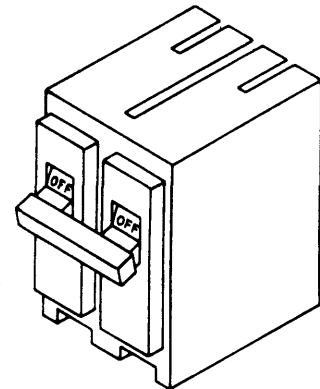

Double Circuit Breaker

More and more circuit breakers are being used in place of fuses. A circuit breaker looks something like a toggle switch, with a handle that lets it be used just like a switch to turn power on and off. Inside each breaker is a fairly simple mechanism which in case of overload trips the breaker and disconnects the load. If a breaker trips because of overload, in most brands you must force the handle beyond the OFF position, then return it to ON, to reset it. On some brands however, the handle merely goes to the OFF position; reset it by returning it to the ON position.

What is to be done when a breaker trips or a fuse blows?
Most people will say: reset the breaker, or install a new fuse. Correct, but first find out why the fuse blew. Fuses are the safety valves of electrical installations.

WIRING COLOR GUIDE	
—	WHITE WIRE <i>neutral</i>
—	BLACK WIRE <i>hot</i>
—	RED WIRE <i>hot</i>
—	RARE WIRE <i>ground wire</i>



How The Ground Wire Works in Plastic Wall Boxes

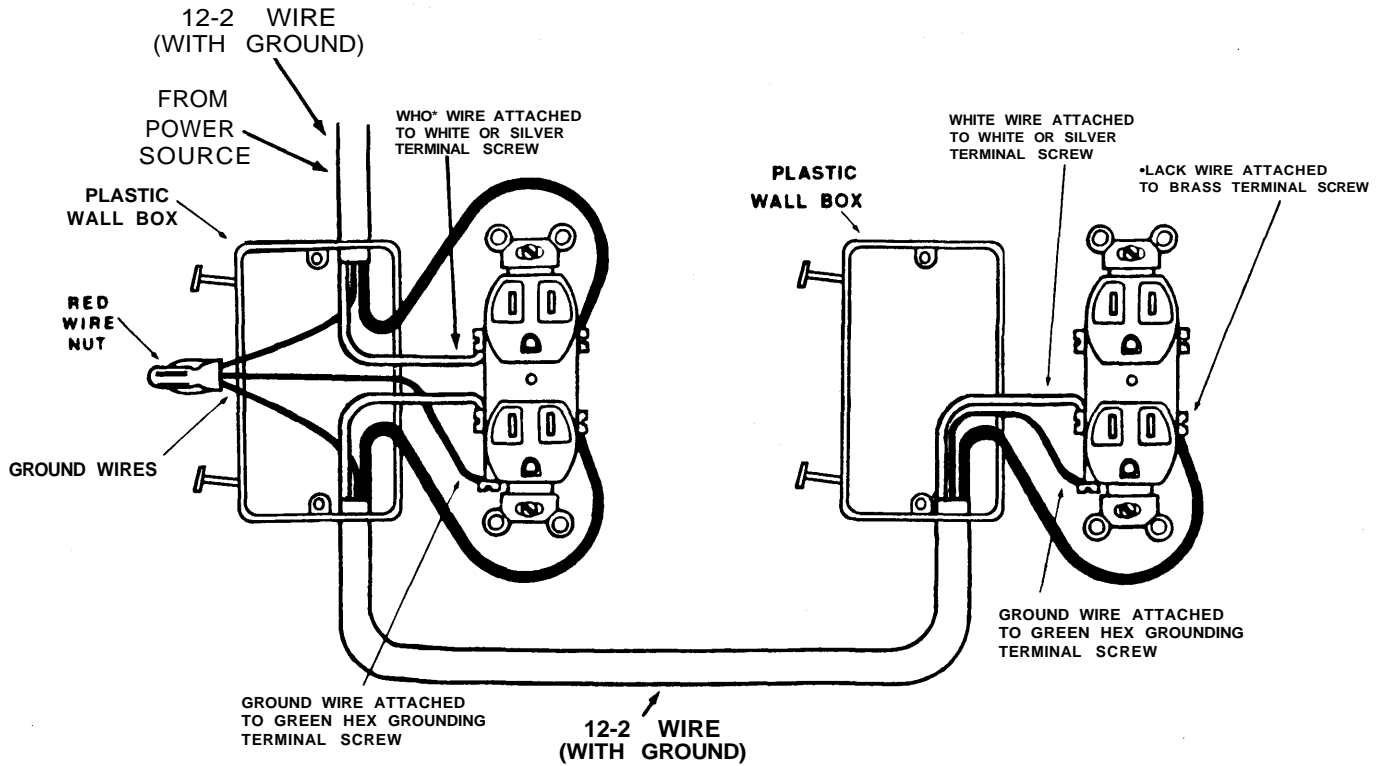

THE WIRING IN PLASTIC AND METAL BOXES IS THE SAME, EXCEPT FOR THE GROUND WIRE. THE GROUND WIRE ATTACHES TO THE METAL BOXES, IN PLASTIC IT DOES NOT

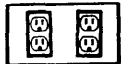

WIRING COLOR GUIDE	
—	WHITE WIRE <i>NEUTRAL</i>
—	BLACK WIRE <i>HOT</i>
—	—
—	—
—	BARE WIRE <i>GROUND WIRE</i>

How to Wire Outlets

WIRING TWO OUTLETS

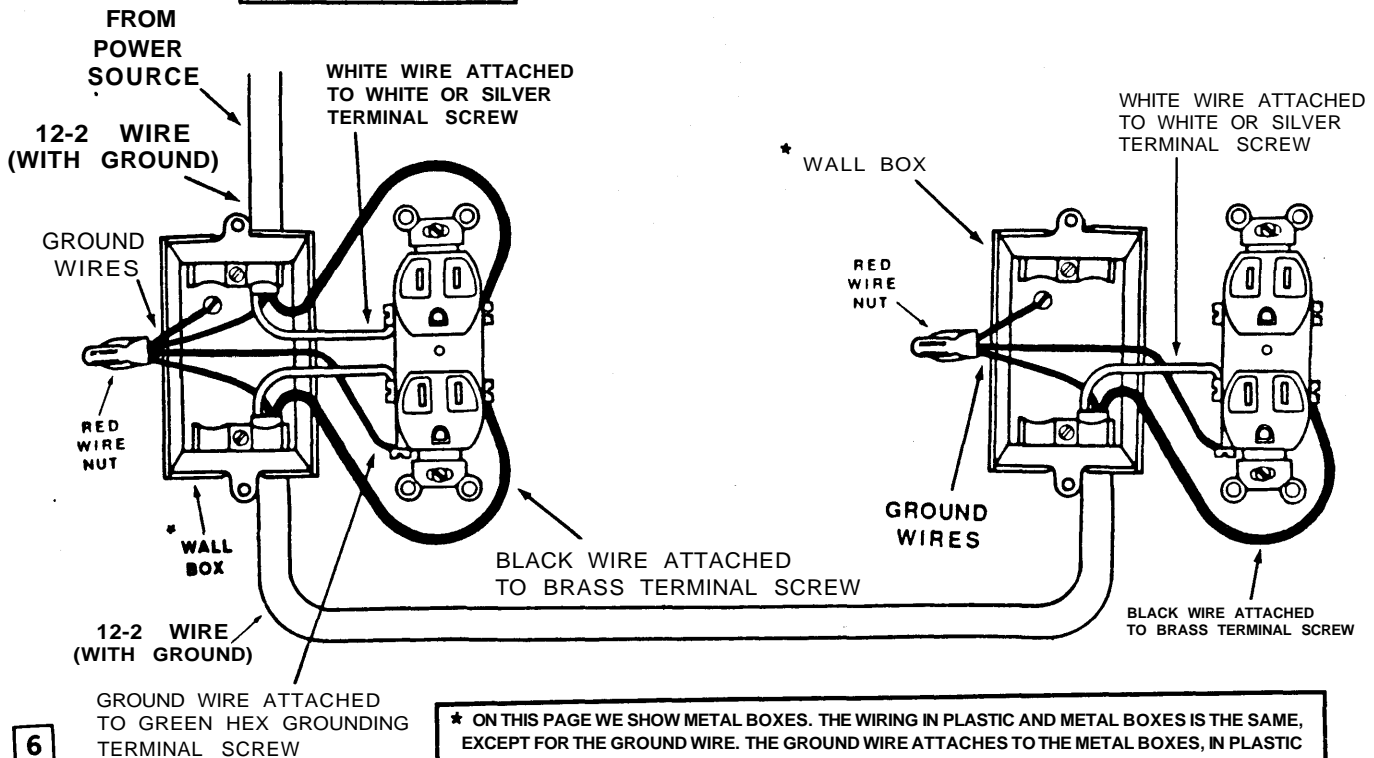

6

* ON THIS PAGE WE SHOW METAL BOXES. THE WIRING IN PLASTIC AND METAL BOXES IS THE SAME, EXCEPT FOR THE GROUND WIRE. THE GROUND WIRE ATTACHES TO THE METAL BOXES, IN PLASTIC IT DOES NOT, SEE PAGE 6 AND 7 FOR MORE ON HOW THE GROUND WIRE WORKS IN PLASTIC BOXES.



WIRING COLOR GUIDE	
	3 WHITE WIRE NEUTRAL
	BLACK WIRE HOT
	RED WIRE HOT
	BARE WIRE GROUNDWIRE

How The Ground Wire Works in Plastic Wall and Ceiling Boxes

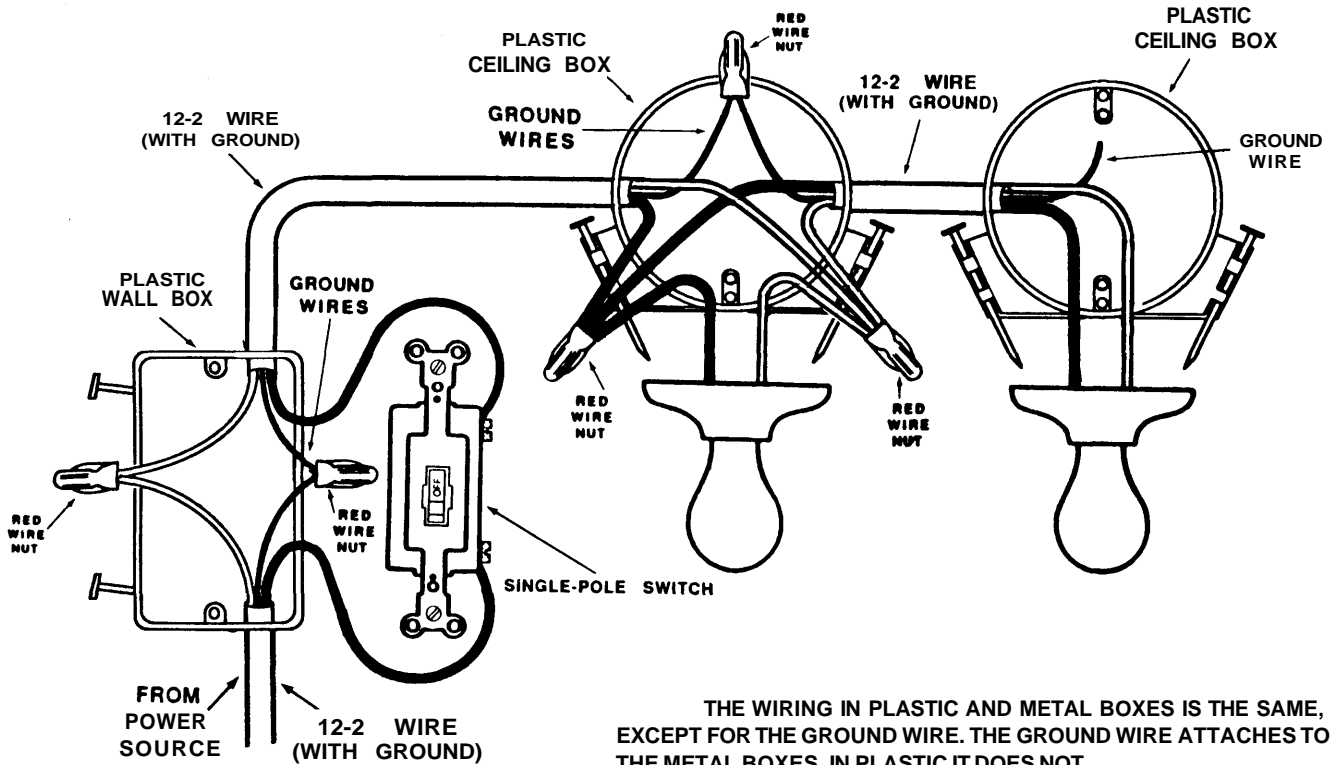

THE WIRING IN PLASTIC AND METAL BOXES IS THE SAME, EXCEPT FOR THE GROUND WIRE. THE GROUND WIRE ATTACHES TO THE METAL BOXES, IN PLASTIC IT DOES NOT

WIRING COLOR GUIDE	
	WHITE WIRE NEUTRAL
	BLACK WIRE HOT
	RED WIRE HOT
	BARE WIRE GROUNDWIRE

How To Wire Single Pole Switch With Switch Controlling Two Lights



WIRE NUT GUIDE	
	USE RED WIRE NUTS WHERE WIRE NUTS ARE USED ON THIS PAGE INCLUDING GROUND WIRES

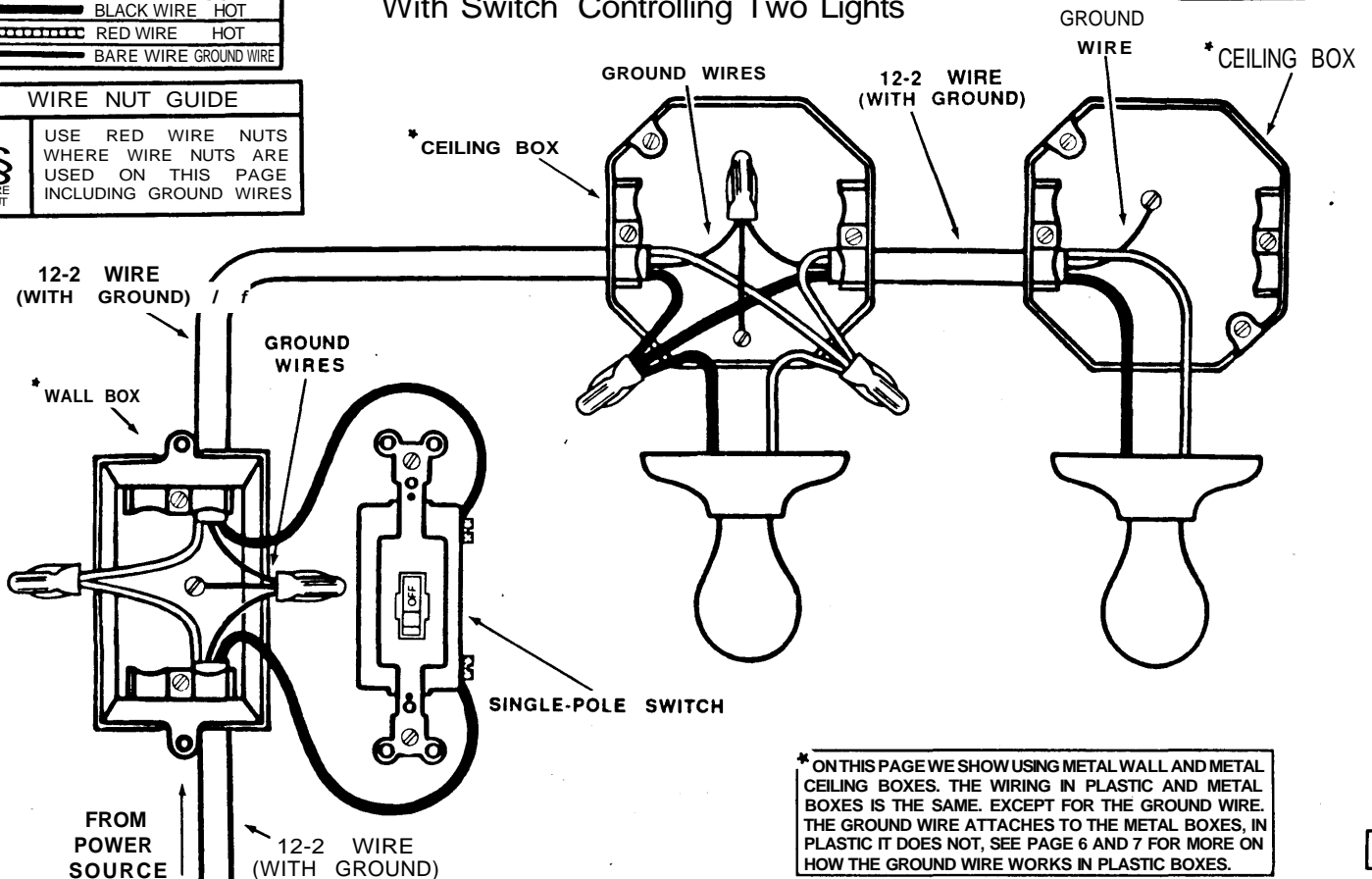

* ON THIS PAGE WE SHOW USING METAL WALL AND METAL CEILING BOXES. THE WIRING IN PLASTIC AND METAL BOXES IS THE SAME. EXCEPT FOR THE GROUND WIRE. THE GROUND WIRE ATTACHES TO THE METAL BOXES, IN PLASTIC IT DOES NOT, SEE PAGE 6 AND 7 FOR MORE ON HOW THE GROUND WIRE WORKS IN PLASTIC BOXES.

All About Electric Wire

CHECK WITH LOCAL CODES ON WIRING SIZES NEEDED FOR YOUR WIRING PROJECT

Chart Shows Copper Wire Size, Amps and Watts		
Wire Size (Actual Size)	Amps (Also Fuse or Circuit Breaker size)	Watts (Based on 120 Volts) at 80% loaded
• NO. 14 wire	15 amps	1800 watts
• NO. 12 wire	20 amps	2400 watts
• NO. 10 wire	30 amps	3600 watts
~ NO. 8 wire	40 amps	4800 watts
~ NO. 6 wire	50 amps	6000 watts

The larger the wire gauge number the smaller the diameter of the wire.

Chart Shows Color Coding of Wires and Terminal Screws		
Color of Wire	Color of Terminal Screw	Hot — Neutral or Grounding Wire
White	Silver or White	Neutral Wire
Black	Brass	Hot Wire
Red	Brass	Hot Wire
Green	Green	Grounding Wire
Bare Wire	Green	Grounding Wire

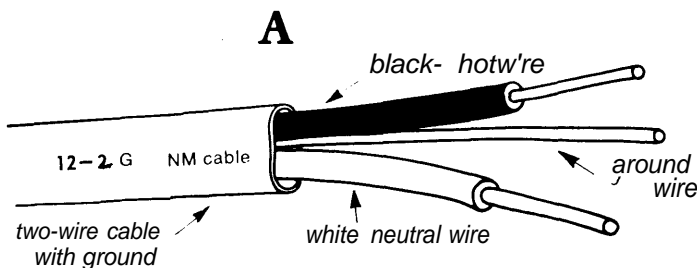

In Example "A" above, the numbers and letters stamped on the electric wire has the following meaning.

The "12" means it is No. 12 wire in size.

The "2" means it has two wires.

The "G" means with ground wire.

The "N-M" means non-metallic

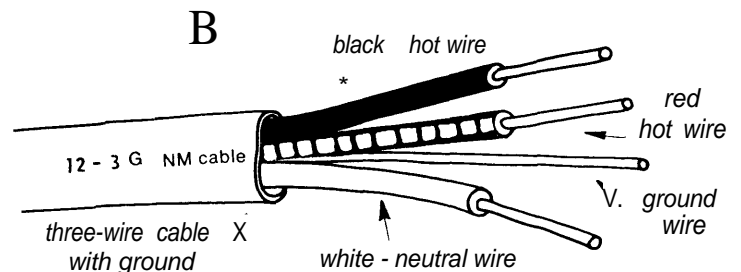

In Example "B" above, it is exactly like Example A except it has three wires instead of the two.

All About Electric Wire

When doing any electrical wiring, you have to use the right size fuses or multi-breakers to protect the electric wire against any overloads or short circuits. Also, wire can handle only so many watts before it becomes overloaded and blows fuses or kicks breakers off. Check below.

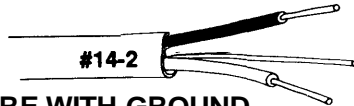

#14-2 WIRE WITH GROUND

When working with No. 14 wire, use a 15 amp fuse or a 15 amp breaker to protect it against overloads or short circuits.

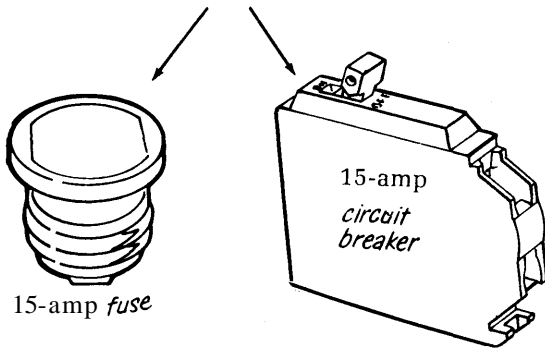

#12-2 WIRE WITH GROUND

When working with No. 12 wire, use a 20 amp fuse or a 20 amp breaker to protect it against overloads or short circuits.

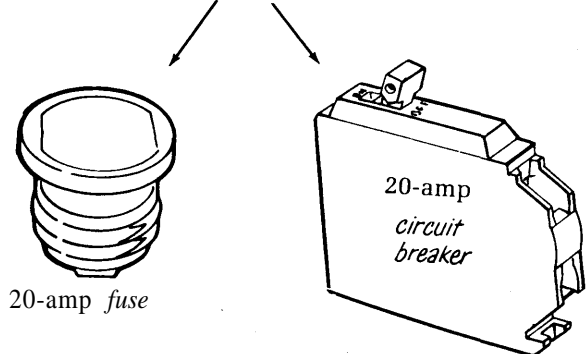

Color coding of wire

- The black wire is **HOT**
- The white wire is **NEUTRAL**

Etch this wiring rule in your memory and keep it there. NEVER CONNECT THE BLACK (HOT) WIRE TO THE WHITE (NEUTRAL) WIRE. (Exception: see page 20)

Connect the black wire to the brass-colored terminal on switches, receptacles, sockets, fuse boxes, and to the black wires on pull chain fixtures. The white (neutral or ground wire—also called the "continuous wire") is grounded at the electric service switch. Connect it to the silver or light-colored terminal of all receptacles, etc., and to the white wire on all lighting fixtures. Again—never hook to the hot wire!

Important

ALWAYS SHUT OFF POWER TO THE CIRCUIT YOU WILL BE WORKING ON, OR THE ENTIRE HOUSE IF YOU ARE NOT SURE WHICH FUSE OR BREAKER CONTROLS THE CIRCUIT. DOUBLE CHECK WITH A TESTING DEVICE TO BE ABSOLUTELY SURE THE CIRCUIT IS DEAD.

How To Use Wirenuts and Screw Terminals

HOW TO PUT ON WIRENUT

WIRE NUTS JOIN WIRE ENDS



Step 1. Strip off about 1 inch of insulation from ends of wires you're going to join. Twist the stripped ends clockwise at least one and one-half turns.



Step 2. Snip $\frac{3}{8}$ to $\frac{1}{2}$ inch off the twisted wires so the ends are even.

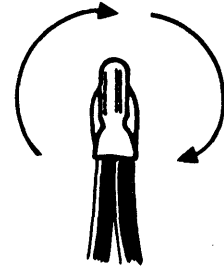

Step 3. Screw the wirenut on clockwise.

HOW TO JOIN WIRE TO SCREW TERMINALS

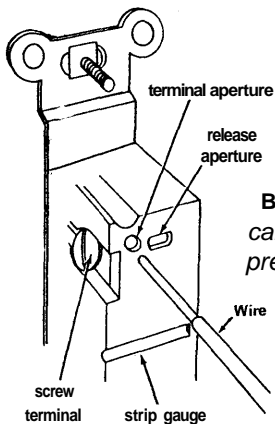

BACKWIRED OUTLETS AND SWITCHES can be loosened from the wires by pressing a screwdriver point into the release aperture.

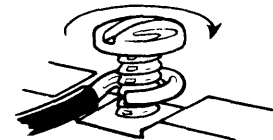

Step 1. Strip $\frac{3}{16}$ inch of insulation off the wire end. Then use a pair of needle nose pliers to form a half loop in the bare wire.

Step 2. Hook the wire clockwise around the screw terminal. As you tighten the screw the loop will close. Always strip wires so no more than $\frac{1}{16}$ inch of bare wire extends out beyond the screw head.



Wrong way

Right way

BACKWIRED OUTLETS AND SWITCHES

HOW TO JOIN SEVERAL WIRES TO SCREW TERMINALS

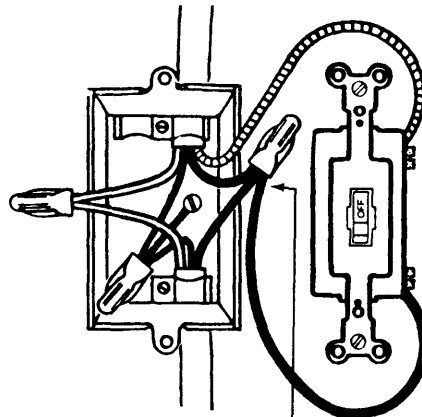

Pigtail splice

The electrical code requires that only one wire may be attached to a screw terminal — the above picture shows the only approved way to do this — it is called a pigtail splice.

How to Install Wiring in New Walls and Partitions

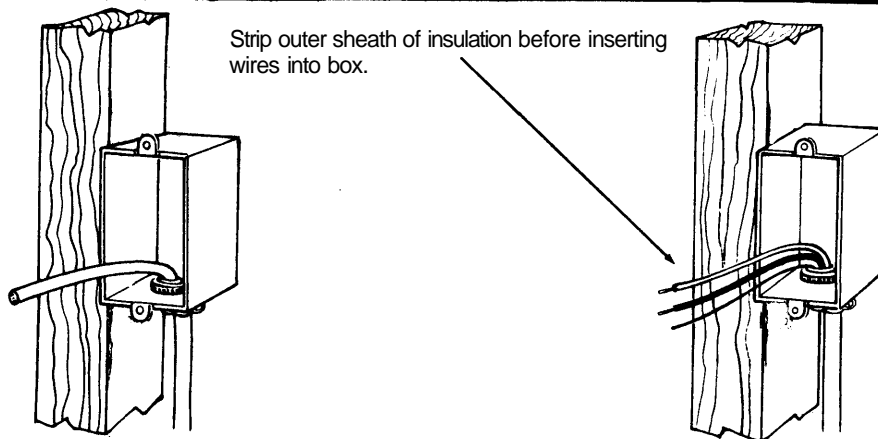
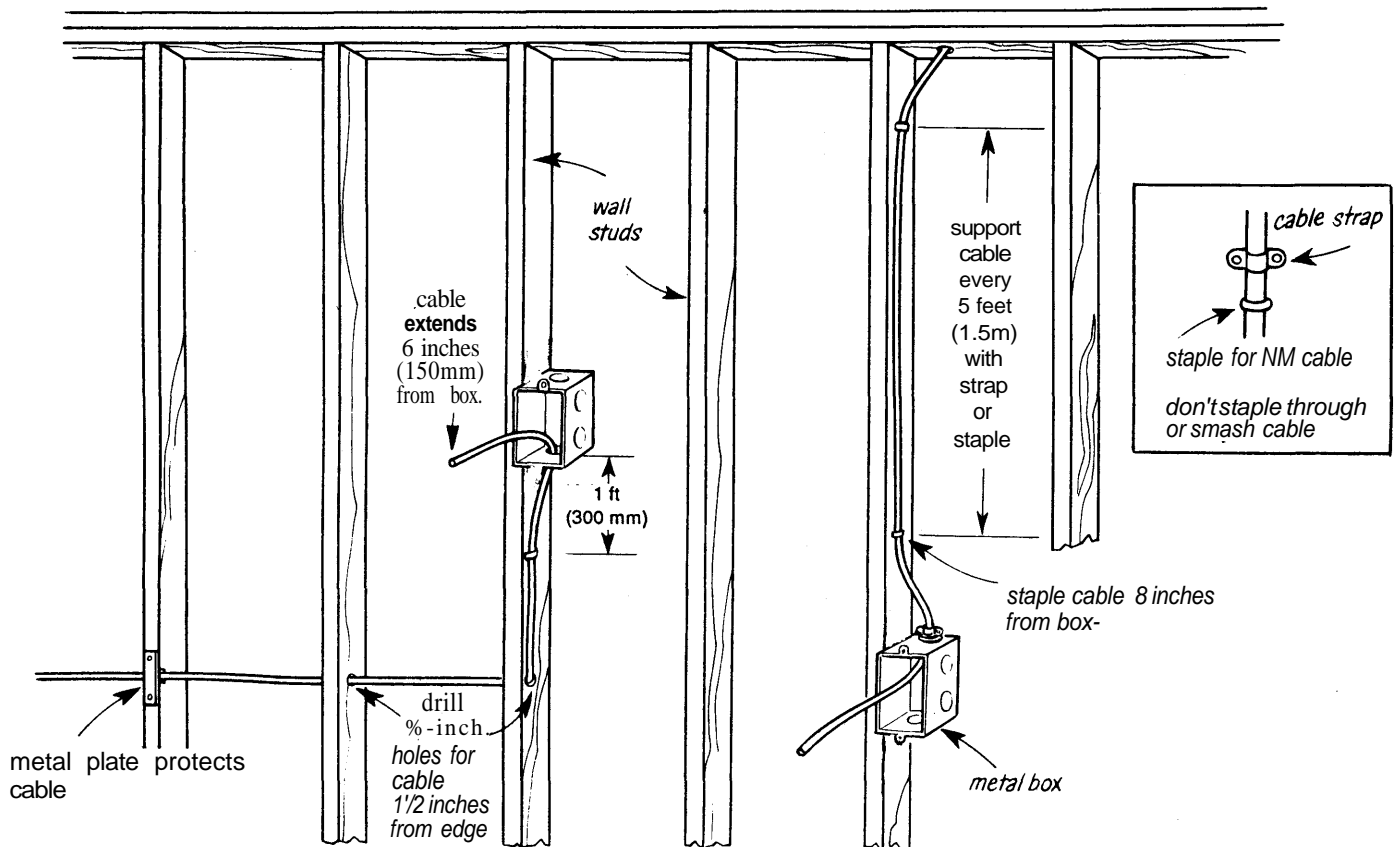

Step 1. Install box. Secure cables to box so that 6 inches of each cable extends from box. (150 mm)

Step 2. Strip outer sheath of insulation to back of box; remove sheath and all separation materials. Strip off $\frac{1}{2}$ to $\frac{3}{4}$ inch insulation from wire ends.

OUTLETS AND SWITCHES

- ALL OUTLETS MUST BE OF THE GROUNDED TYPE.
- Outlets Should Be No More than 12 Ft. Apart.
- Outlets Should Be 12 " High from Floor.
- Switches Should Be 48" High from Floor
- Switches Should Always Be Put on Same Side of Door that the Door Knob Is on.

**CHECK ON LOCAL CODES FOR MORE INFORMATION NEEDED
ON OUTLETS AND SWITCHES FOR YOUR WIRING PROJECT**

The Most Common Measurements for Outlets and Switches

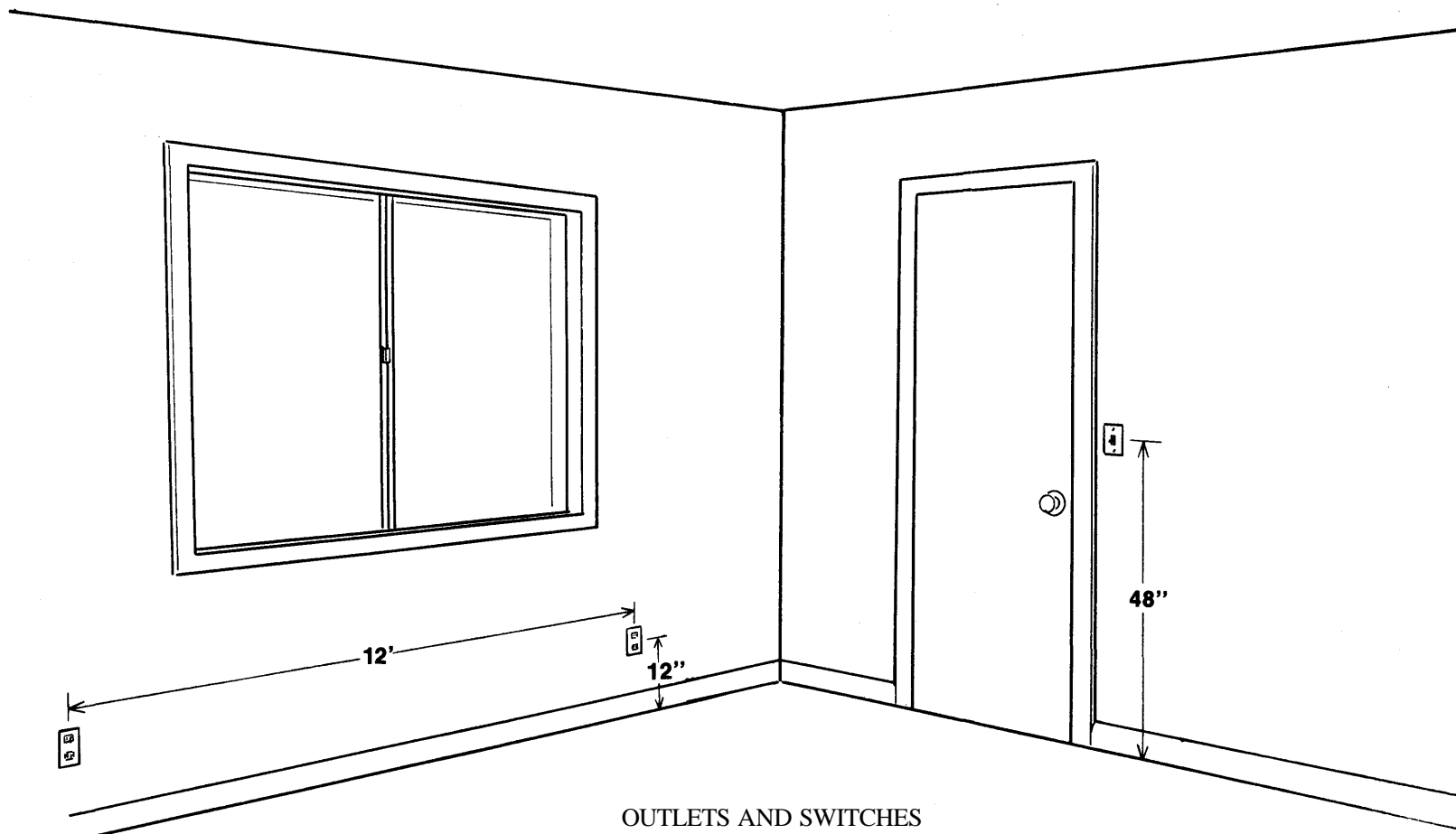

OUTLETS AND SWITCHES

- ALL OUTLETS MUST BE OF THE GROUNDED TYPE.
- Outlets Should Be No More than 12 Ft. Apart.
- Outlets Should Be 12 " High from Floor.
- Switches Should Be 48" High from Floor.
- Switches Should Always Be Put on Same Side of Door that the Door Knob Is on.

**CHECK ON LOCAL CODES FOR MORE INFORMATION NEEDED
ON OUTLETS AND SWITCHES FOR YOUR WIRING PROJECT**

All About The Ground Wire

- USE THE GREEN OR BARE WIRE AS THE GROUND WIRE IN ELECTRICAL WIRING. USE THE GREEN-COLORED TERMINAL SCREW AS THE GROUNDING SCREW IN ANY ELECTRICAL WORK.
- IF YOU ARE USING ELECTRICAL WIRE THAT HAS NO GROUND WIRE IN IT, USE A GROUND WIRE THE SAME SIZE. FOR EXAMPLE, IF YOU ARE USING NUMBER 12 WIRE USE A NUMBER 12 GROUND WIRE.
- USE 10/32" STOVE BOLTS OR MACHINE SCREWS TO ATTACH THE GROUND WIRE TO THE BACK OF WALL BOXES, SWITCH BOXES, CEILING BOXES, AND JUNCTION BOXES.
- THE GROUND WIRE NOT ONLY PROTECTS YOU FROM GETTING SHOCKED, BUT PROTECTS THE ELECTRICAL ITEMS IN YOUR HOUSE FROM GETTING DAMAGED FROM LIGHTNING.

Checking an Outlet's Ground

TEST THE GROUNDING OF A NEWLY INSTALLED OUTLET BY INSERTING ONE PROBE OF THE VOLTAGE TESTER INTO THE SEMICIRCULAR GROUND SLOT AND THE OTHER INTO EACH OF THE ELONGATED SLOTS SUCCESSIVELY. THE TESTER SHOULD LIGHT WHEN THE PROBE IS PLUGGED INTO THE HOT SLOT. (IN A MODERN OUTLET THIS SLOT IS SLIGHTLY SHORTER THAN THE OTHER SLOT.) IF NEITHER SLOT LIGHTS THE TESTER, THE OUTLET IS NOT GROUNDED AND THE WIRING MUST BE CORRECTED.

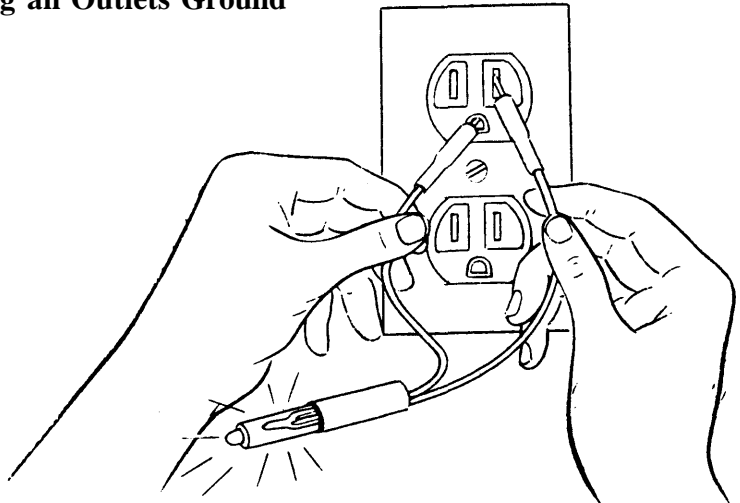

Underwriter's knot..

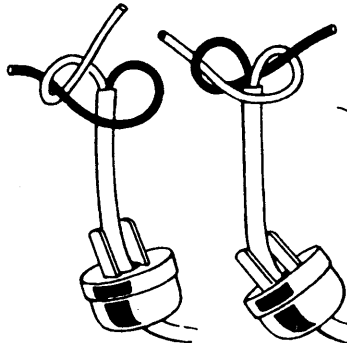

To (reflect cord from strain, lu'N loo) corrs us shown . . .

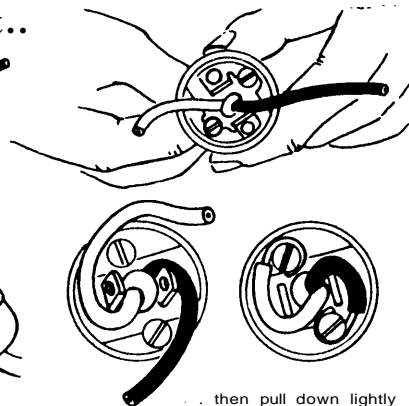

. . . then pull down lightly into recess between prongs

How to Wire Electric Dryers

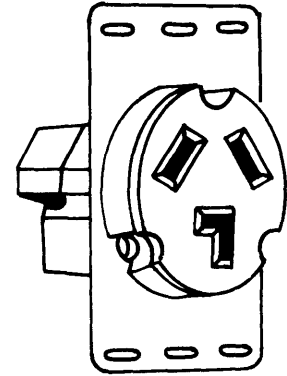
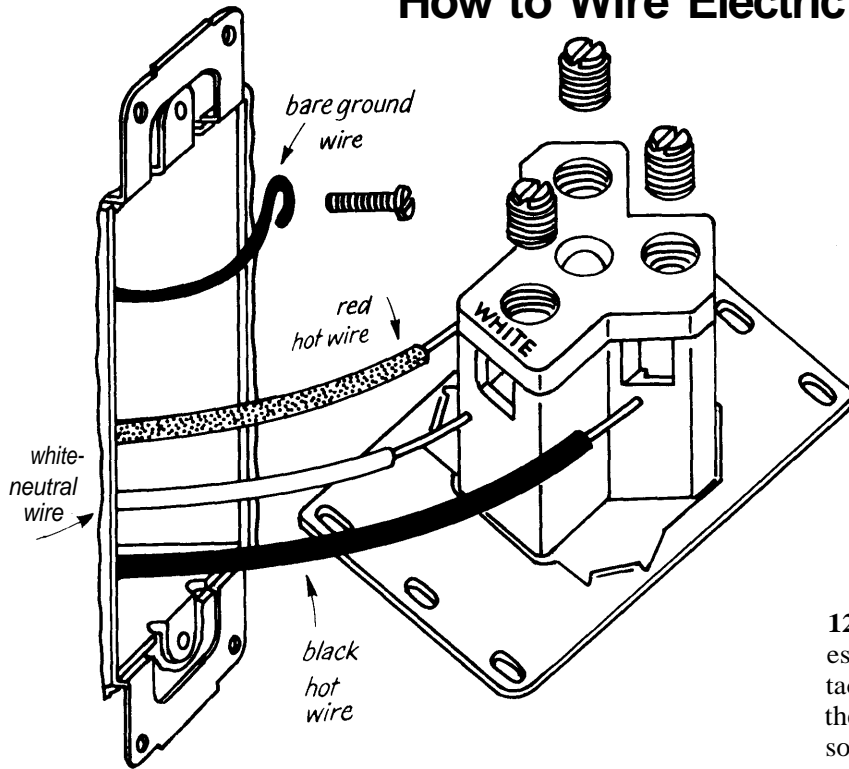

Recessed Dryer Receptacle

120/240-volt, 30-ampere, grounded. Designed especially for clothes driers, this large receptacle supplies 240 volts for the heating coils of the drier and 120 volts for such standard accessories as the timer and the pilot light.

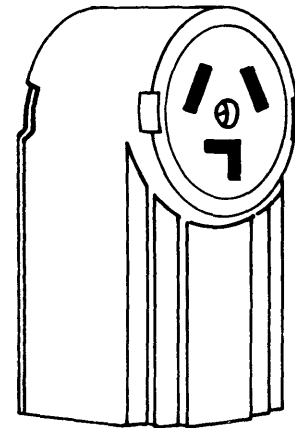
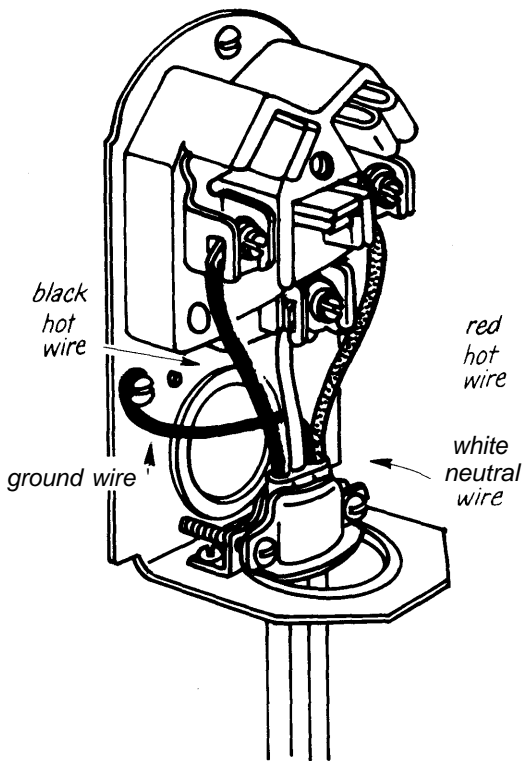

Surface Dryer Receptacle

USE WIRE SIZE 10-3 WITH GROUND FOR ELECTRIC DRYERS.

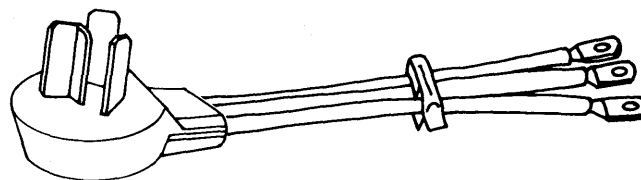

Dryer Cord

How to Wire Electric Range

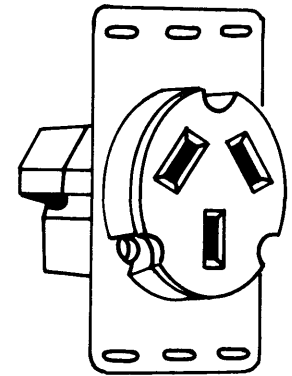
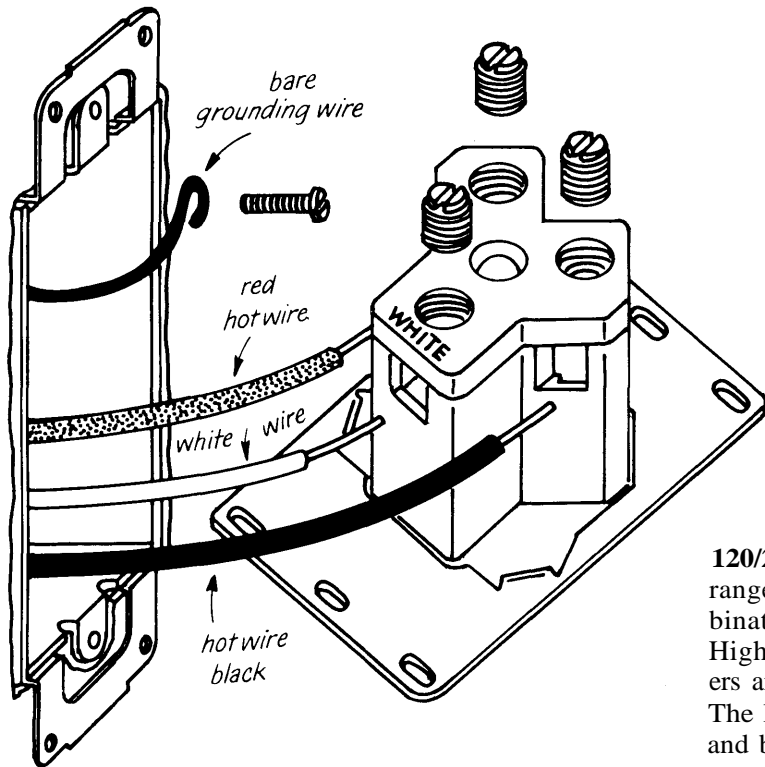

Recessed Range Receptacle

120/240-volt, 50-ampere, grounded. An electric range requires the high amperage and the combination of voltages provided by this receptacle. High-temperature settings of the oven and burners are connected to the 240-volt circuit. The low temperature settings, timer, pilot lights and built-in receptacles operate on 120 volts.

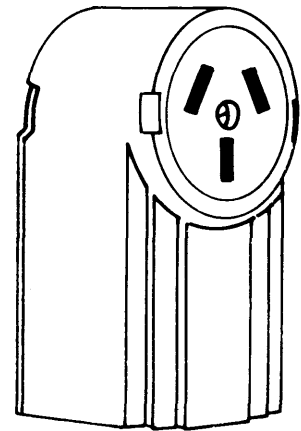
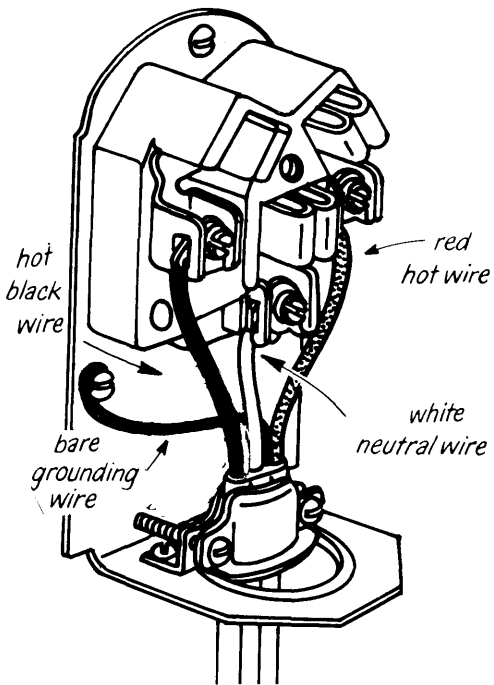



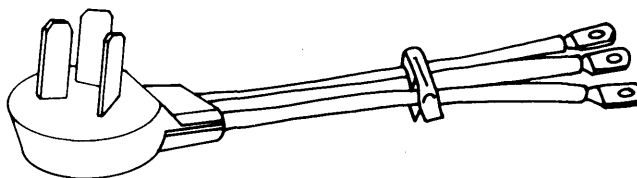

Surface Range Receptacle

USE WIRE SIZE 6-3 WITH GROUND FOR ELECTRIC RANGES.



Range Cord

Watts Used by Different Electrical Items

Approximate Ratings	Approximate Ratings
Air conditioner (central) 5000 (room, 1/3 ton) 800 (room, 3/4 ton) 1300 (room, 1 ton) 1600	Power tools Drill, 1/4 inch..... 150 3/8 inch 250 1/2 inch 350 Grinder 200 Lather..... 300 Lawn Mower 300 Sander, portable 750 Saw, bander 250 bench 300-600 jig 250 radial arm 1500 sabre..... 200 Soldering iron 150
Blender 250-1000 Bottle warmer 400 Broiler 1500 Can opener 150 Clock 2 Coffee maker..... 500-1000 Corn popper 500 Dishwasher 1000-1500 Dryer 4000-8000 Electric blanket 200 Fan (attic) 400 (exhaust for range) 250 (portable) 100 Floor polisher..... 350 Food warmer 500 Freezer, frostless 350-500 standard..... 250-400 Fryer, deep fat 1400 Frying pan, automatic 1100 Furnace, coal 400 gas..... 150 oil..... 750 Garbage disposer 400-900 Grill 1000 Hair Dryer..... 260 Heater (hot water) 2000-5000 (room) 1250 Hot plate (per burner)..... 750 Iron (hand) 1050 (mangle) 1600 Knife sharpner Knife sharpner..... 100 Lamp (heat) 250 (sun)..... 400 Lights (flourescent circlines)..... 22-32 (flourescent tubes) 15-60 (incandescent, per bulb)10 & up (night light)..... 7 Microwave oven 600 Mixer 150	Projector (slide or movie) 350 Radio, console 150 portable..... 50 Range, oven 4000-8000 top 4000-8000 Refrigerator, frostless 300-450 standard..... 250-350 Roaster..... 1350 Rotisserie..... 1400 Sewing machine 75 Shaver 10 Stereo, hi-fi..... 300 Sump pump 300 Television, black and white 250 color..... 300 Toaster..... 1000 Vacuum cleaner 300-800 Waffle iron 900 Washing machine 600
	<div style="display: flex; justify-content: space-around; align-items: flex-start;"> <div style="text-align: center;"> <p>Coffeemaker 600 watts</p>  </div> <div style="text-align: center;"> <p>Television Set 300 watts</p>  </div> </div> <div style="display: flex; justify-content: space-around; align-items: flex-start; margin-top: 20px;"> <div style="text-align: center;"> <p>Automatic Toaster 1100 watts</p>  </div> <div style="text-align: center;"> <p>Table Lamp 100 watts</p>  </div> </div>

How to Find the Cause of a Short Circuit

Most short circuits occur in flexible cords, plugs, or appliances. Look for black smudge marks on faceplates or frayed or charred cords connected to dead circuit. Simply replace damaged cord or plug before installing new fuse or resetting breaker.

If you find no visible signs of trouble, though, you'll have to trace your way through circuit. To do this, turn off all wall switches and unplug every appliance on dead circuit. Then install new fuse or reset tripped breaker.

If fuse blows right away, pull out fuse or make sure circuit breaker is OFF. Remove each faceplate and inspect device and wiring. Look for charred wire insulation, wire shorted against back of metal box, or device literally falling apart. Replace defective switch or receptacle or faulty wiring. Then install new fuse or reset breaker.

If new fuse doesn't blow or breaker doesn't trip right away, turn on each wall switch, one by one, until fuse blows or circuit breaker trips.

When turning on wall switch causes fuse to blow or breaker to trip, short is in fixture outlet controlled by switch or in ON position of switch. With circuit dead, inspect outlet and switch for charred wire insulation and faulty connections. Replace faulty fixture or switch. Then install new fuse or reset breaker.

If turning on wall switches doesn't blow fuse or trip breaker, trouble is in appliance. Plug in and turn on appliances one by one. When fuse blows or breaker trips again, you'll know you've found offending appliance. Then install new fuse or reset breaker.

If circuit went dead as soon as you turned appliance on, appliance or its switch is probably defective and should be replaced or repaired.

If circuit went dead as soon as you plugged appliance in, plug or cord is probably at fault and should be replaced.

Note: If none of the above solves the problem and your fuse or breaker still blows or trips, your wiring is at fault. Call an electrician.

Important

ALWAYS SHUT OFF POWER TO THE CIRCUIT YOU WILL BE WORKING ON, OR THE ENTIRE HOUSE IF YOU ARE NOT SURE WHICH FUSE OR BREAKER CONTROLS THE CIRCUIT. DOUBLE CHECK WITH A TESTING DEVICE TO BE ABSOLUTELY SURE THE CIRCUIT IS DEAD.

Color of Wire	Color of Screw	Hot - Neutral or Grounding Wire
White	Silver or White	Neutral Wire
Black	Brass	Hot Wire
Red	Brass	Hot Wire
Green	Green	Grounding Wire
Bare Wire	Electrical Box Ground	Grounding Wire

How to Fix Fluorescent Light Fixtures

SYMPTOM	CAUSE	CURE
Lamp won't light	Tube burned out (blackened ends)	Replace tube
	Improper installation	Take out and install again
	Fuse blown or circuit breaker	Replace or reset tripped
	Starter burned out	Replace starter
	Dirty tube (rapid-start only)	Remove tube, wash, rinse, dry, and replace
	Tubeholder broken	Replace tubeholder
	Fixture too cold	Raise temperature to at least 50°F
Lamp flickers (Note: New tubes may flicker a short time after installation.)	Oxide film buildup on tube pins	Rotate tube in tubeholders once or twice
	Poor contact with tubeholders	Realign tubeholders; straighten and sand tubeholders if necessary
	Improper installation	Take out and install again
	Tube nearly worn out (blackened ends)	Replace tube
	Oxide buildup on tube pins	Rotate tube in tubeholders once or twice
Ends of tube are discolored (Note: Darkened bands about 2 inches from ends are normal.) If preheat type with new tubes Discolored on one end only	Fixture, too cold	Raise temperature to at least 50°F
	Tube almost worn out	Replace tube
	Defective starter	Replace starter
Ends of tube glow, but center doesn't	Temperamental tube	Remove tube; turn end for end
	Defective ballast	Replace ballast
Lamp fixture hums	Defective starter	Replace starter
	Defective ballast	Replace ballast
	Ballast incorrectly installed	Check wiring on ballast diagram and correct
Lamp fixture hums	Wrong type of ballast	Check wattage and type; replace ballast
	Defective ballast	Replace ballast

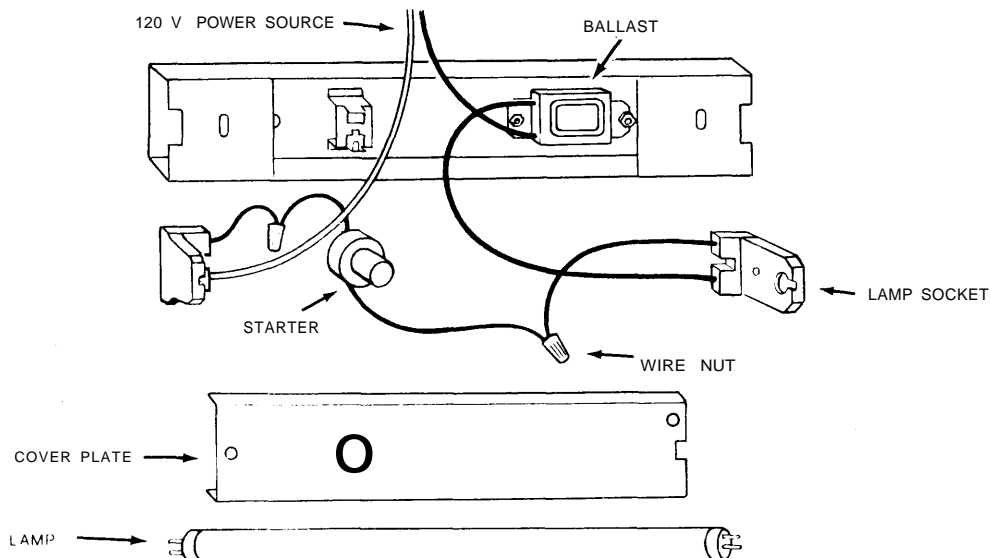

How To Wire into Boxes, Fixtures and Switches

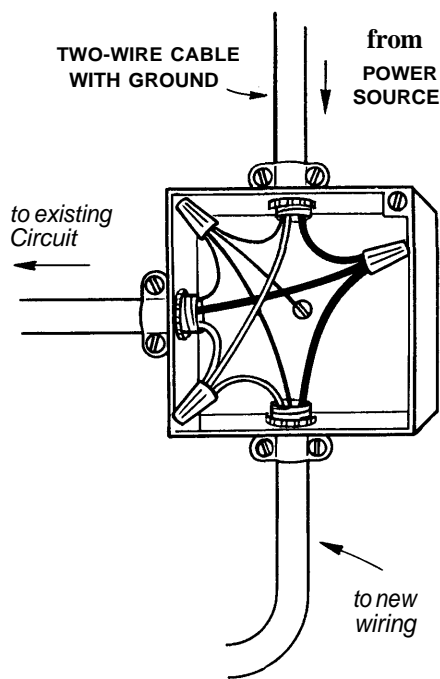

HOW TO WIRE INTO A JUNCTION BOX

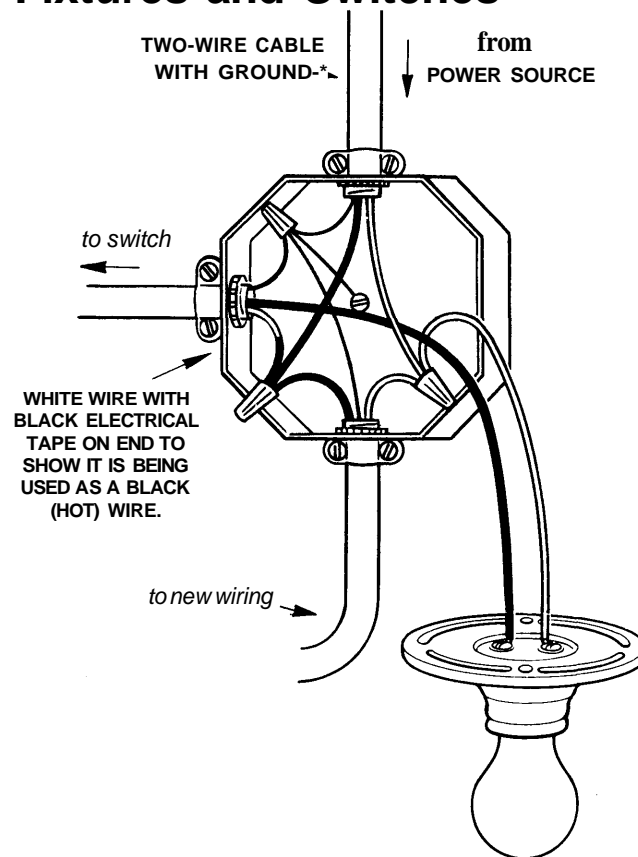

HOW TO WIRE INTO A FIXTURE

Most switches in a home are of the single-pole or three-way types. Single-pole switches have two terminals of the same color and a definite right side up. All switches are wired into hot wires only; with a single-pole switch, it makes no difference which hot wire goes to which terminal.

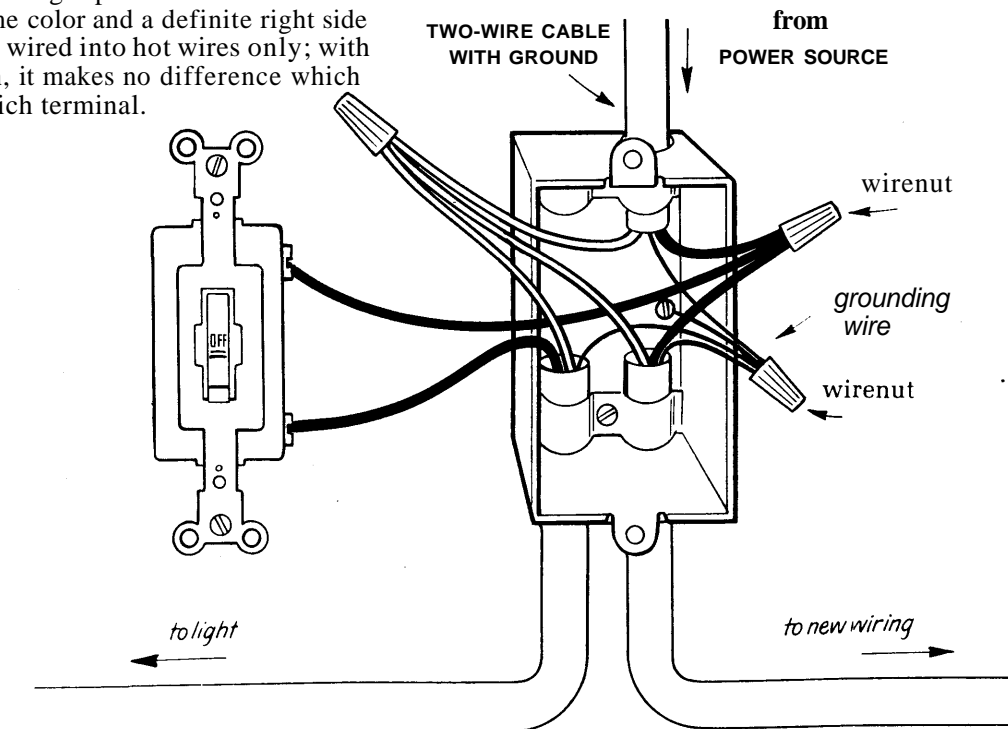

Color Coding of Wires, Screw Terminals, Etc.

**Chart Shows Color Coding of Wires and Terminal Screws
For Switches, Outlets, Light Fixtures**

Color of Wire	Color of Terminal Screw	Hot - Neutral or Grounding Wire
White	Silver or White	Neutral Wire
Black	Brass	Hot Wire
Red	Brass	Hot Wire
Green	Green	Grounding Wire
Bare Wire	Electrical Box Ground	Grounding Wire

COLOR CODING OF WIRE — WITH ONE EXCEPTION

Up to this point we have assumed that a white wire is always a neutral wire. Wires that are black and red are always hot. But one situation offers an exception to this color coding.

The one exception to the rule is if the power source first goes thru the light fixture and then to the switch, you have to use a white wire as a hot black wire.





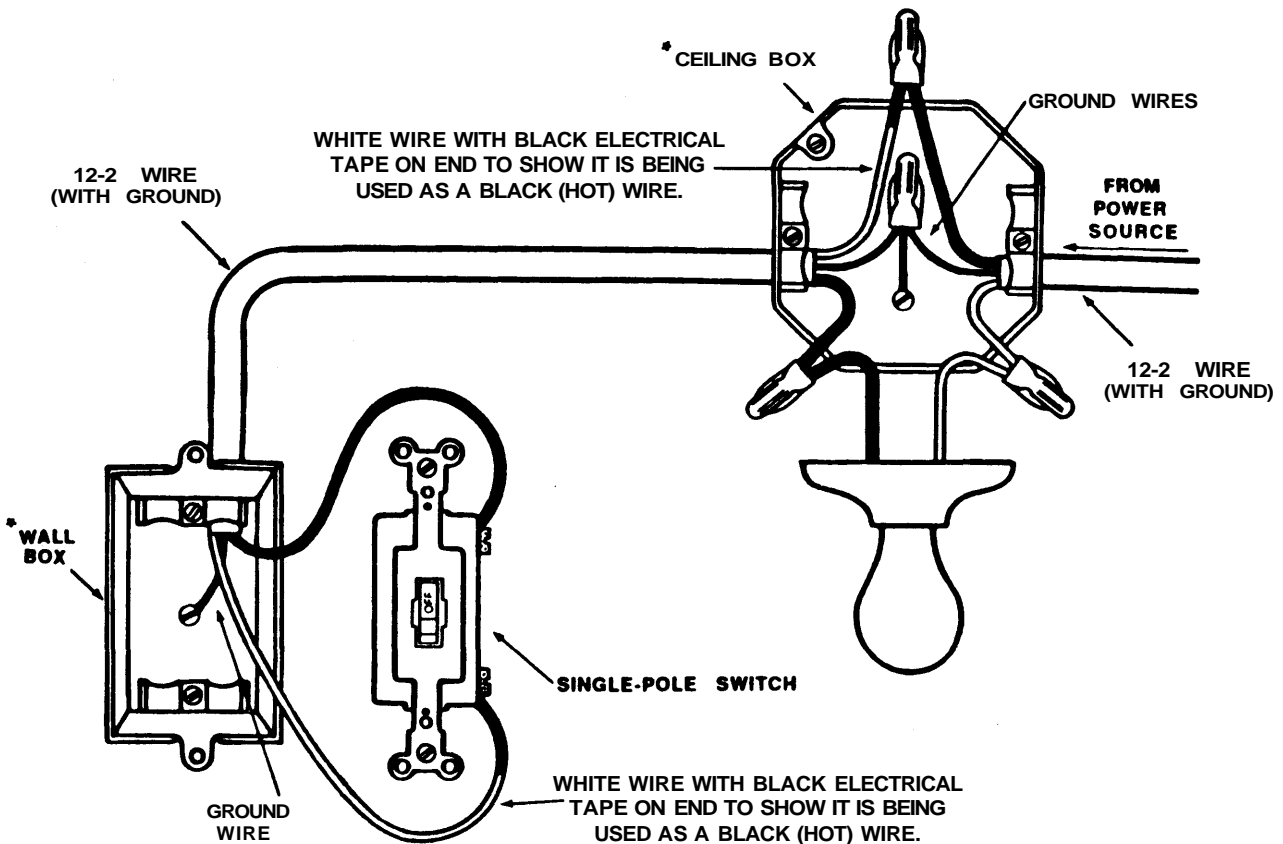

























When using a white wire this special way, paint the wire insulation black (or tape it with black tape) at both ends where it joins a hot terminal or another hot wire. This identifies it as a hot wire. A example of this is shown in the picture below.

The Picture below is called a Switch Loop.



Electrical Symbols and a Wiring Layout

STANDARD ELECTRICAL SYMBOLS

	CEILING OUTLET		CEILING FAN		PUSH BUTTON
	WALL OUTLET		WALL FAN		DOORBELL
	CEILING LIGHTING OUTLET		CEILING JUNCTION BOX		DOOR BUZZER
	DUPLEX CONVENIENCE OUTLET		WALL JUNCTION BOX		RADIO OUTLET
	SWITCH - CONVENIENCE OUTLET		CEILING PULL SWITCH		TELEVISION
	WEATHERPROOF OUTLET		CLOCK OUTLET		SINGLE POLE SWITCH
	ELECTRIC RANGE		THERMOSTAT		DOUBLE-POLE SWITCH
	ELECTRIC DRYER		GENERATOR		THREE-WAY SWITCH
	230-VOLT POLARIZED OUTLET		ELECTRIC MOTOR		FOUR-WAY SWITCH
	SPECIAL PURPOSE OUTLET		NIGHT LIGHT		WEATHERPROOF SWITCH

All About Switches

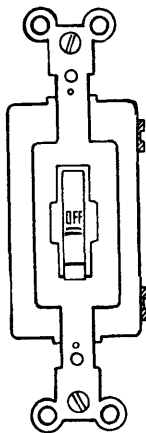

A Single Pole Switch

A single-pole switch controls a light or receptacle from one location. It has two brass-colored terminals and "on" and "off" markings on the handle.

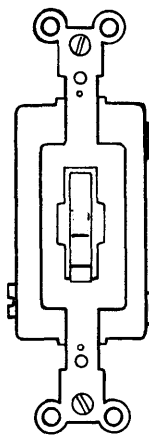

A Three Way Switch

Three-way switches, used in pairs to control a light or receptacle from two locations, have three terminals; one black or copper-colored and two brass or silver-colored. There are no "on" and "off" markings.

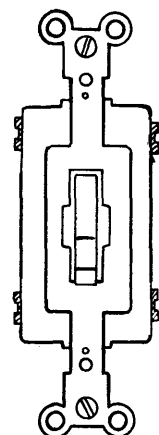

A Four Way Switch

A four-way switch works with three-way switches to control a light or receptacle from three or more locations. It has four brass-colored terminals and no "on" and "off" markings.

- Switches Should Be 48" High from Floor.
- Switches Should Always Be Put on Same Side of Door that the Door Knob Is on.

How to Add New Outlets to Existing Ones

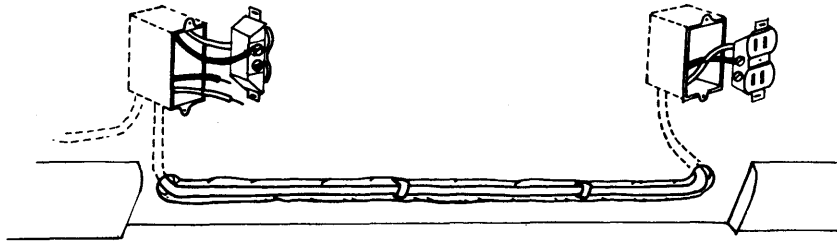

THE PICTURE ABOVE SHOWS HOW TO ADD A NEW OUTLET TO AN EXISTING ONE BY RUNNING THE WIRE BEHIND THE BASEBOARD. USE 12-2 WIRE WITH GROUND, USE GROUNDED OUTLETS, BE SURE YOU DONT OVERLOAD THE CIRCUIT, COVER WIRE WITH A METAL PLATE OR USE METAL CABLE TO PROTECT WIRE. CHECK WITH LOCAL CODE TO SEE IF THIS WIRING ARRANGEMENT IS PERMITTED IN YOUR AREA.

Step 1. Remove molding around door *frame* and as much baseboard as necessary on either side of door.

Step 2. Run cable between jamb and frame, notching spacers wherever necessary.

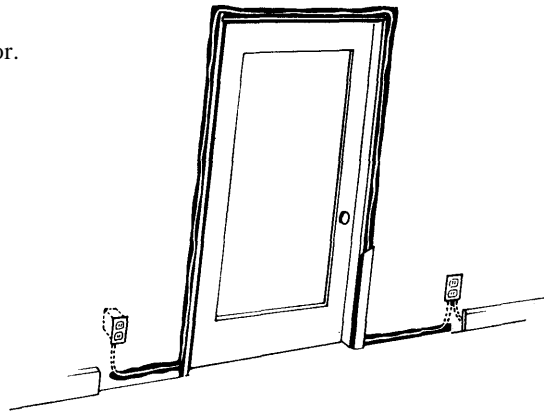

THE PICTURE ABOVE SHOWS HOW TO ADD A NEW OUTLET TO AN EXISTING ONE BY RUNNING THE WIRE BEHIND THE DOOR CASING. USE 12-2 WIRE WITH GROUND, USE GROUNDED OUTLETS, BE SURE YOU DONT OVERLOAD THE CIRCUIT, COVER WIRE WITH A METAL PLATE OR USE METAL CABLE TO PROTECT WIRE. CHECK WITH LOCAL CODE TO SEE IF THIS WIRING ARRANGEMENT IS PERMITTED IN YOUR AREA.

How To Wire Doorbells and Buzzers

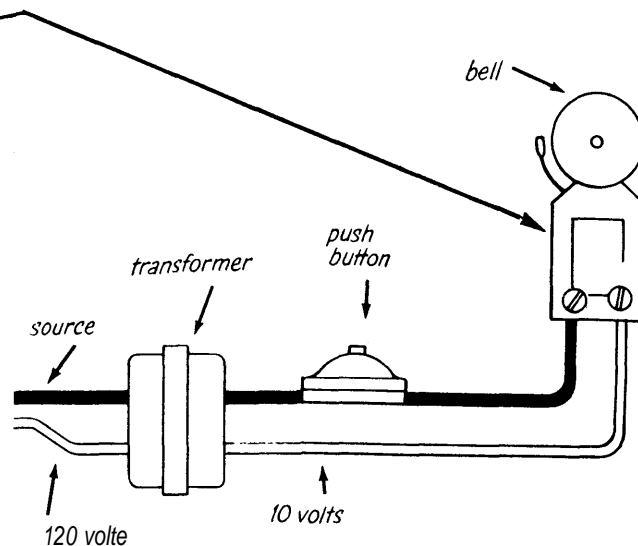
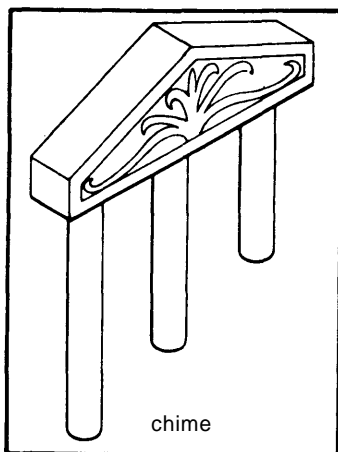

How to Add New Outlets to Existing Ones

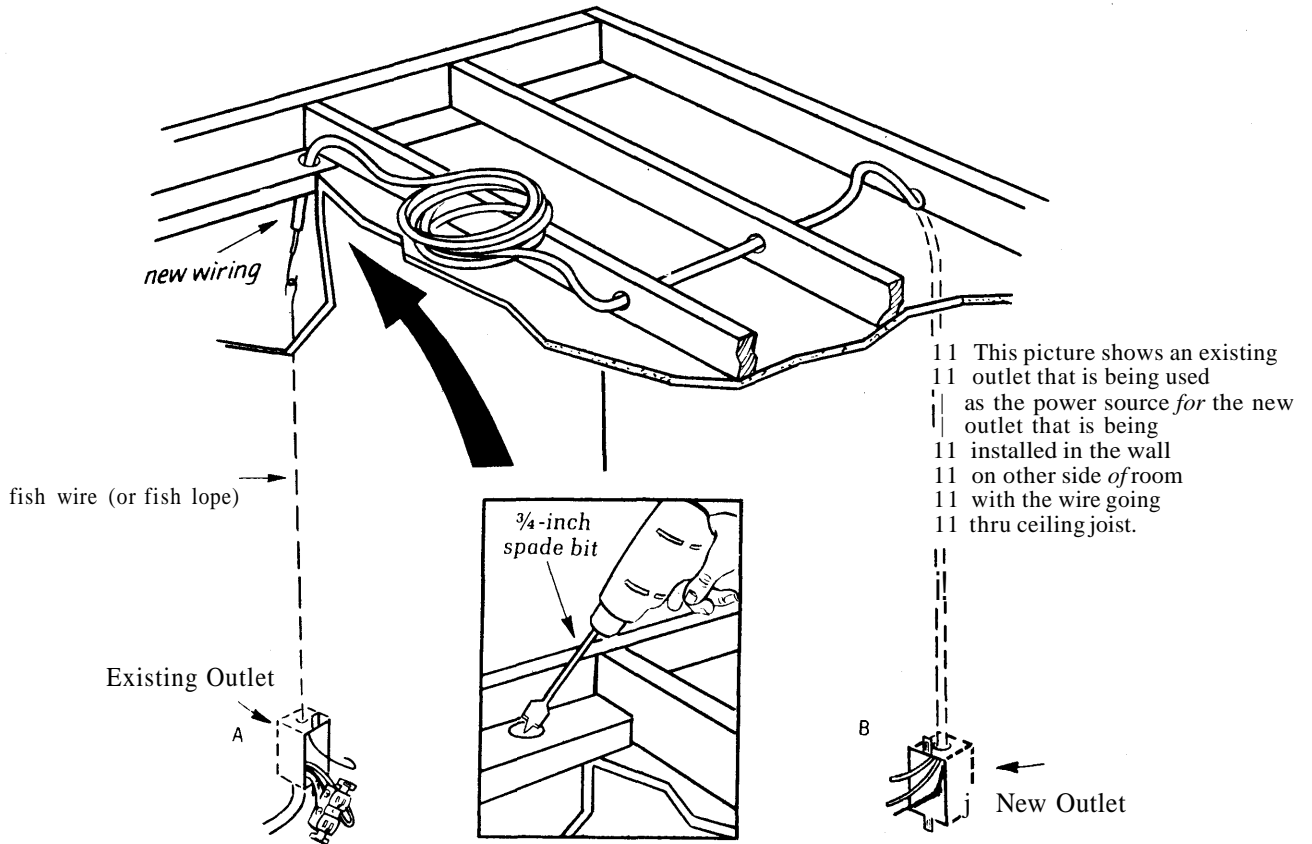

USE 12-2 WIRE WITH GROUND, USE GROUNDED OUTLETS, BE SURE YOU DON'T OVERLOAD THE CIRCUIT. CHECK WITH LOCAL CODE TO SEE IF THIS WIRING ARRANGEMENT IS PERMITTED IN YOUR AREA.

How To Wire Doorbells and Buzzers

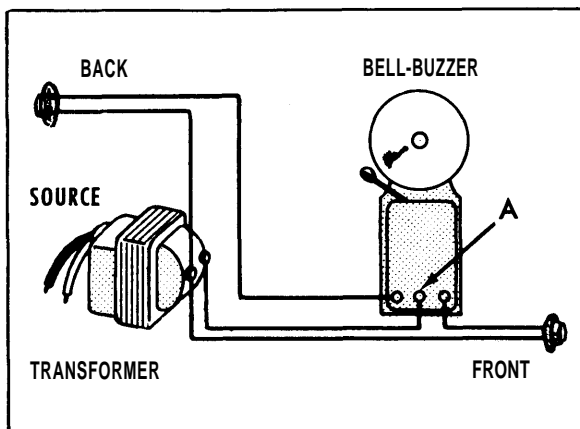

Wiring for a front doorbell and a back-door buzzer.

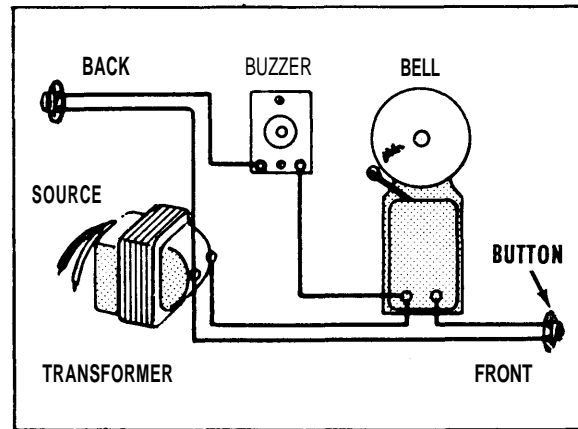

Wiring for a combination bell-buzzer unit.

All About Outlets

A 6/32 threaded screw holds the outlets to the wall box.

These wires going to top part of outlet make both the top and bottom parts of the outlet live. Wire may go in from top or bottom of outlet to do this.

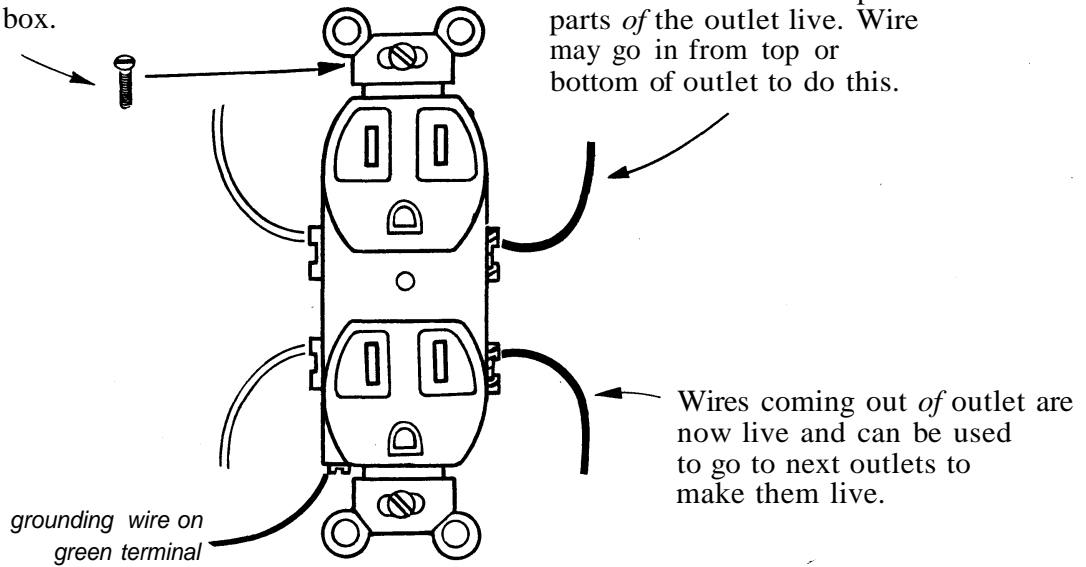

Outlets, also called receptacles, have three different colors of screw terminals. The brass-colored screws are hot terminals and here use the black wire. The white or silver-colored screws are neutral terminals, and here use the white wire. The green screw is the grounding terminal, and here use the bare wire for the grounding wire.

Wiring Layout

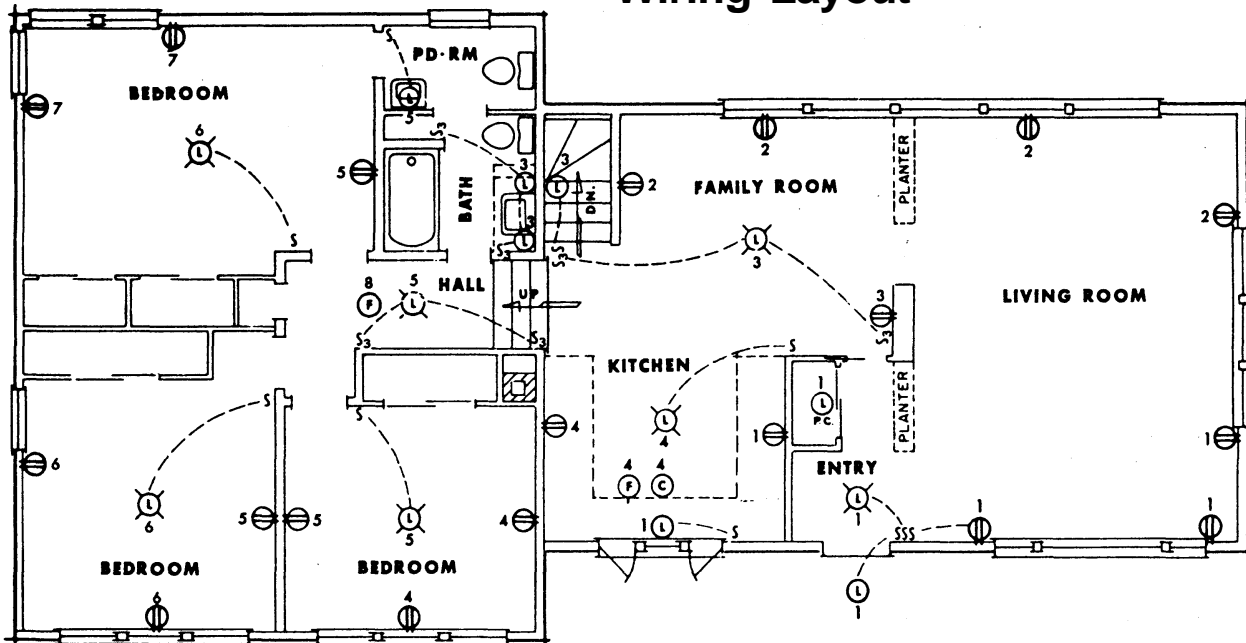



How to Wire Outlets

WIRING ONE OUTLET

WIRING COLOR GUIDE		
	WHITE WIRE	NEUTRAL
	BLACK WIRE	HOT
	RED WIRE	HOT
	BARE WIRE	GROUND WIRE

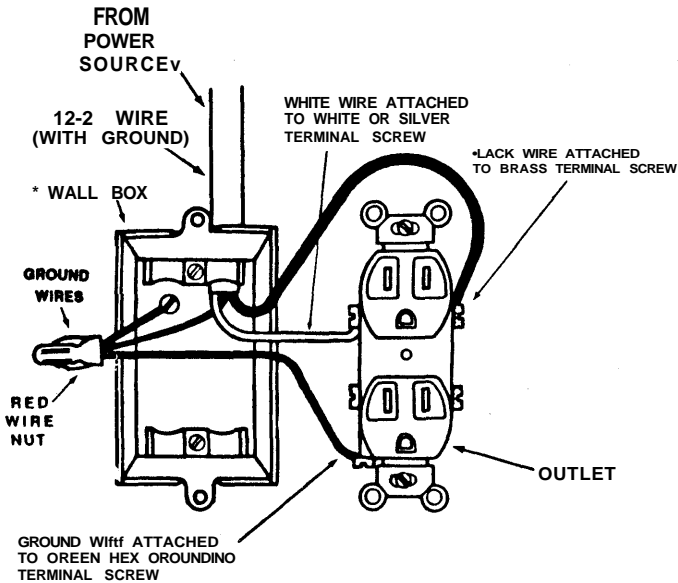

How to Wire Outlets

WIRING TWO OUTLETS

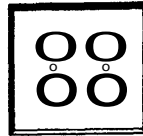

WIRING COLOR GUIDE		
	WHITE WIRE	NEUTRAL
	BLACK WIRE	HOT
	RED WIRE	HOT
	BARE WIRE	GROUND WIRE

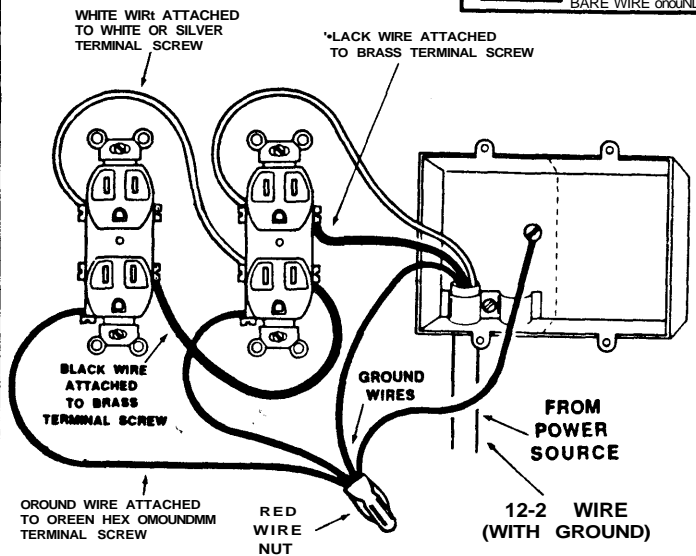

PICTURE ABOVE SHOWS HOW TO PUT TWO OUTLETS IN A DOUBLE BOX

WIRING COLOR GUIDE		
	WHITE WIRE	NEUTRAL
	BLACK WIRE	HOT
	RED WIRE	HOT
	BARE WIRE	GROUND WIRE

How to Wire Outlets

WIRING TWO OUTLETS

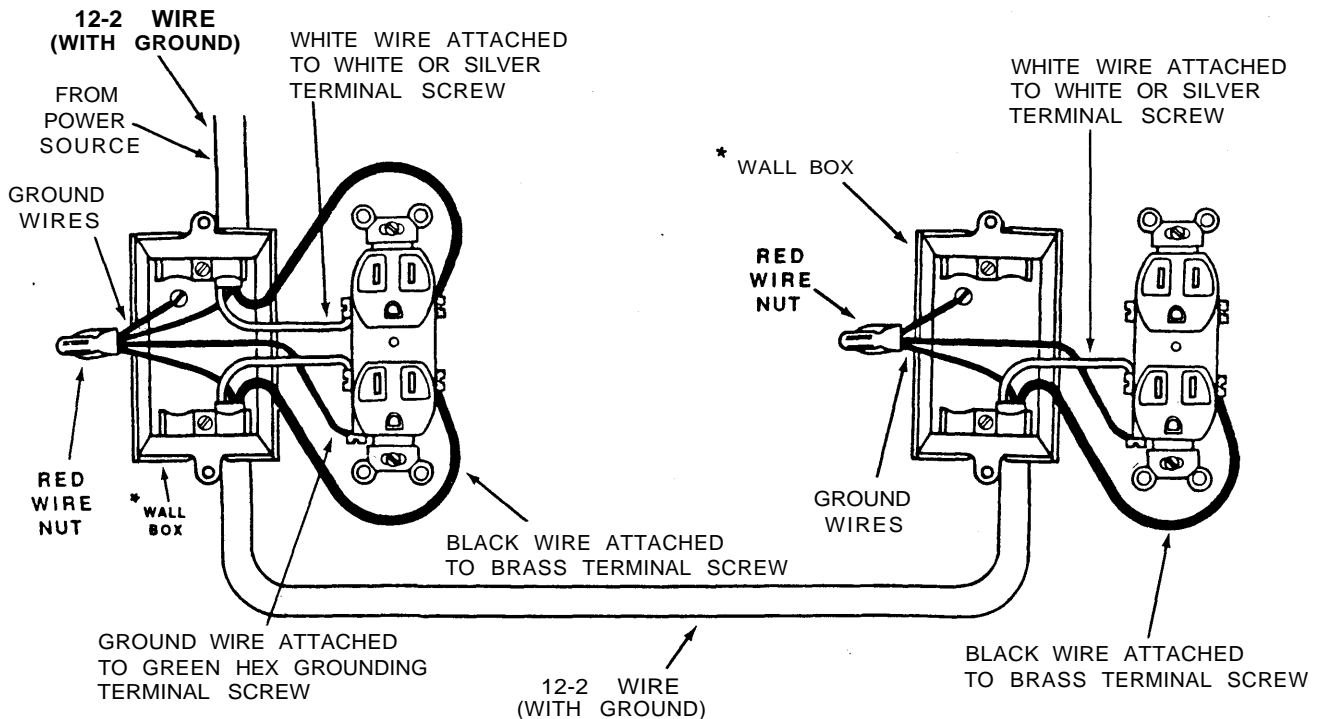
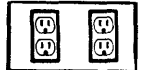

* ON THIS PAGE WE SHOW METAL BOXES. THE WIRING IN PLASTIC AND METAL BOXES IS THE SAME, EXCEPT FOR THE GROUND WIRE. THE GROUND WIRE ATTACHES TO THE METAL BOXES, IN PLASTIC IT DOES NOT, SEE PAGE 6 AND 7 FOR MORE ON HOW THE GROUND WIRE WORKS IN PLASTIC BOXES.

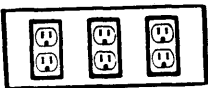

WIRING COLOR GUIDE	
	WHITE WIRE NEUTRAL
	BLACK WIRE HOT
	RED WIRE HOT
	BARE WIRE GROUND WIRE

How to Wire Outlets

WIRING THREE OUTLETS

WIRE NUT GUIDE	
A	USE RED WIRE NUTS WHERE WIRE NUTS ARE USED ON THIS PAGE INCLUDING GROUND WIRES

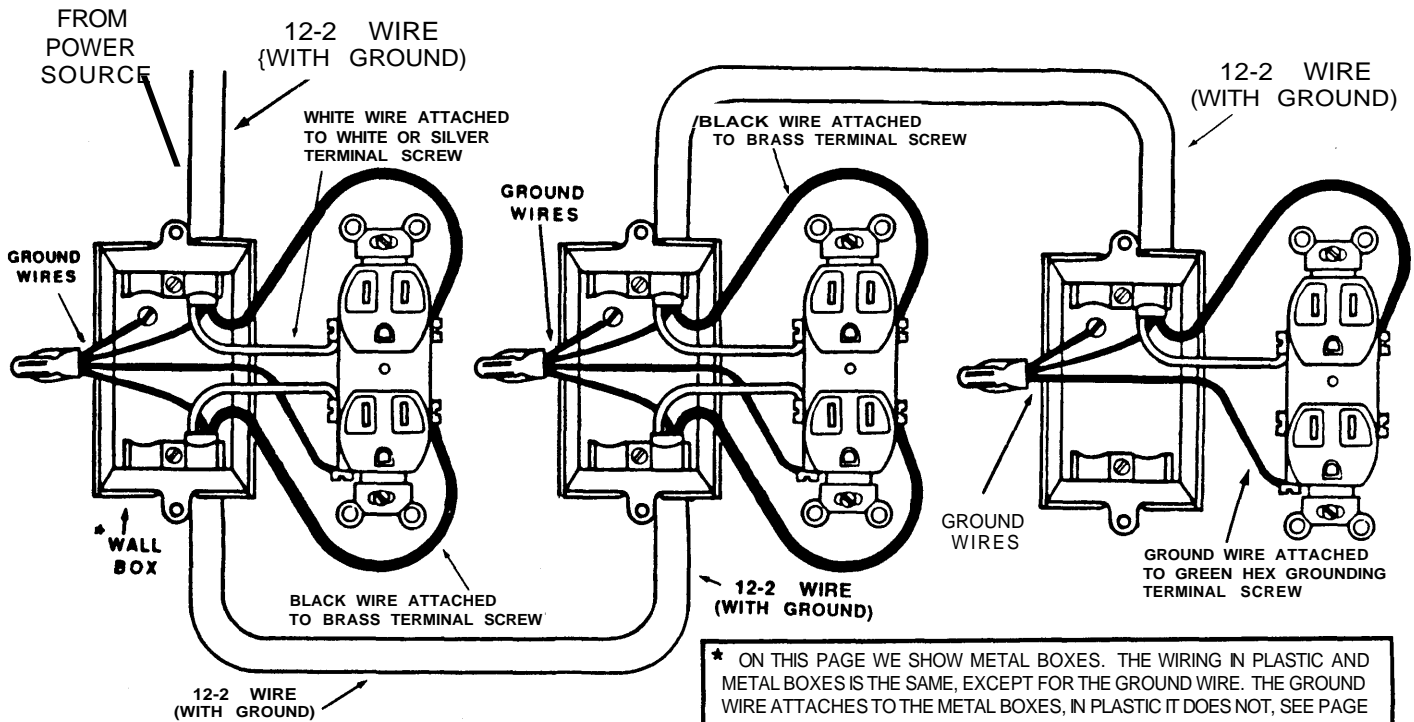

* ON THIS PAGE WE SHOW METAL BOXES. THE WIRING IN PLASTIC AND METAL BOXES IS THE SAME, EXCEPT FOR THE GROUND WIRE. THE GROUND WIRE ATTACHES TO THE METAL BOXES, IN PLASTIC IT DOES NOT, SEE PAGE 6 AND 7 FOR MORE ON HOW THE GROUND WIRE WORKS IN PLASTIC BOXES.

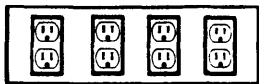

How to Wire Outlets

WIRING FOUR OUTLETS

WIRING COLOR GUIDE	
	WHITE WIRE NEUTRAL
	BLACK WIRE HOT
	RED WIRE HOT
	BARE WIRE GROUND WIRE

WIRE NUT GUIDE	
ft	USE RED WIRE NUTS WHERE WIRE NUTS ARE USED ON THIS PAGE INCLUDING GROUND WIRES

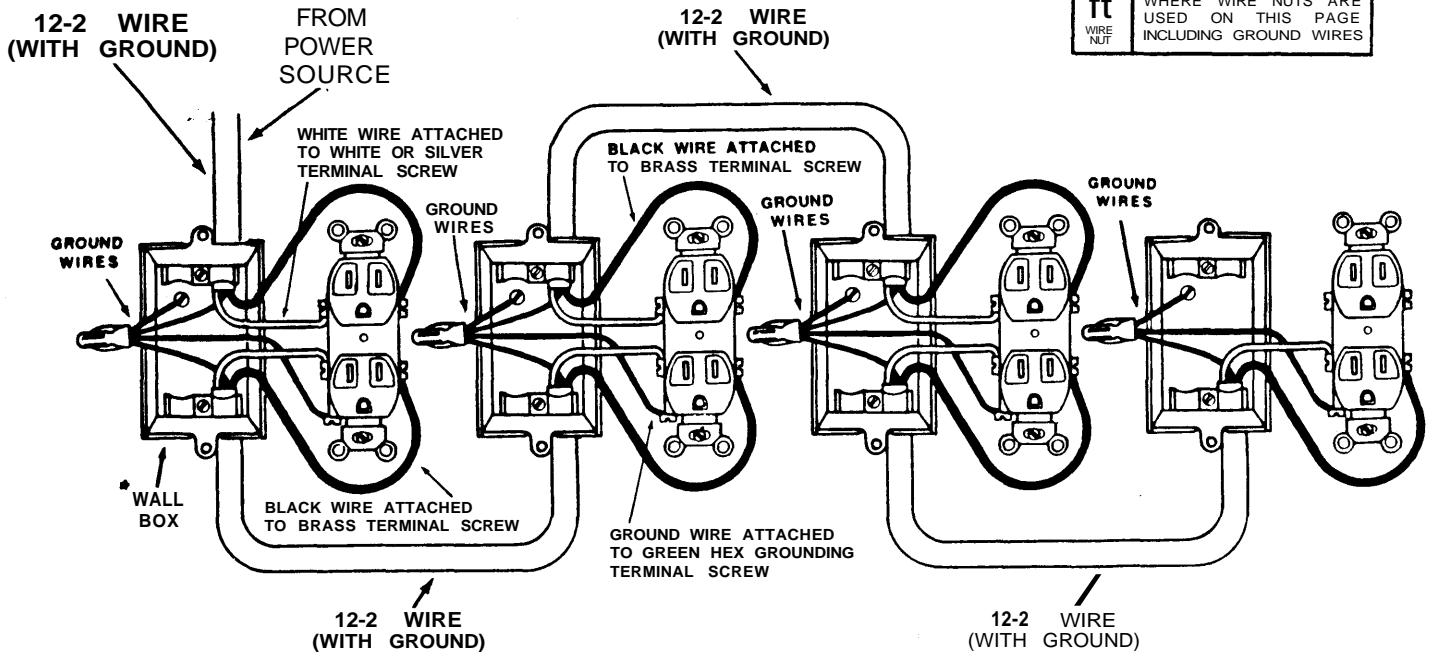

* ON THIS PAGE WE SHOW METAL BOXES. THE WIRING IN PLASTIC AND METAL BOXES IS THE SAME, EXCEPT FOR THE GROUND WIRE. THE GROUND WIRE ATTACHES TO THE METAL BOXES, IN PLASTIC IT DOES NOT, SEE PAGE 6 AND 7 FOR MORE ON HOW THE GROUND WIRE WORKS IN PLASTIC BOXES.



How to wire a split-circuit outlet

WIRING COLOR GUIDE	
	WHITE WIRE NEUTRAL
	BLACK WIRE HOT
	RED WIRE HOT
	BARE WIRE GROUND WIRE

THE SWITCH CONTROLS THE TOP HALF OF THE OUTLET
THE BOTTOM HALF OF OUTLET IS ALWAYS HOT

WIRE NUT GUIDE	
	USE RED WIRE NUTS WHERE WIRE NUTS ARE USED ON THIS PAGE INCLUDING GROUND WIRES

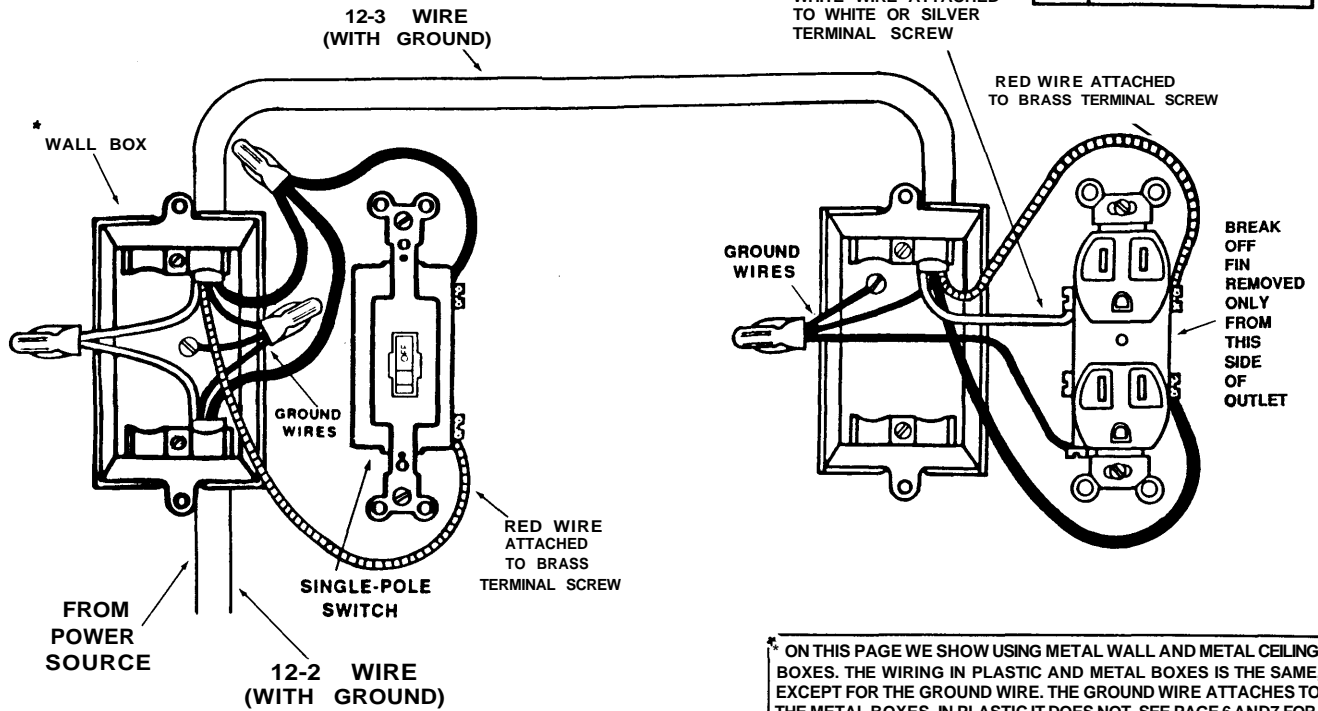

* ON THIS PAGE WE SHOW USING METAL WALL AND METAL CEILING BOXES. THE WIRING IN PLASTIC AND METAL BOXES IS THE SAME, EXCEPT FOR THE GROUND WIRE. THE GROUND WIRE ATTACHES TO THE METAL BOXES, IN PLASTIC IT DOES NOT, SEE PAGE 6 AND 7 FOR MORE ON HOW THE GROUND WIRE WORKS IN PLASTIC BOXES.

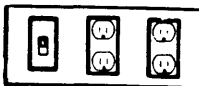

How to wire split-circuit outlets



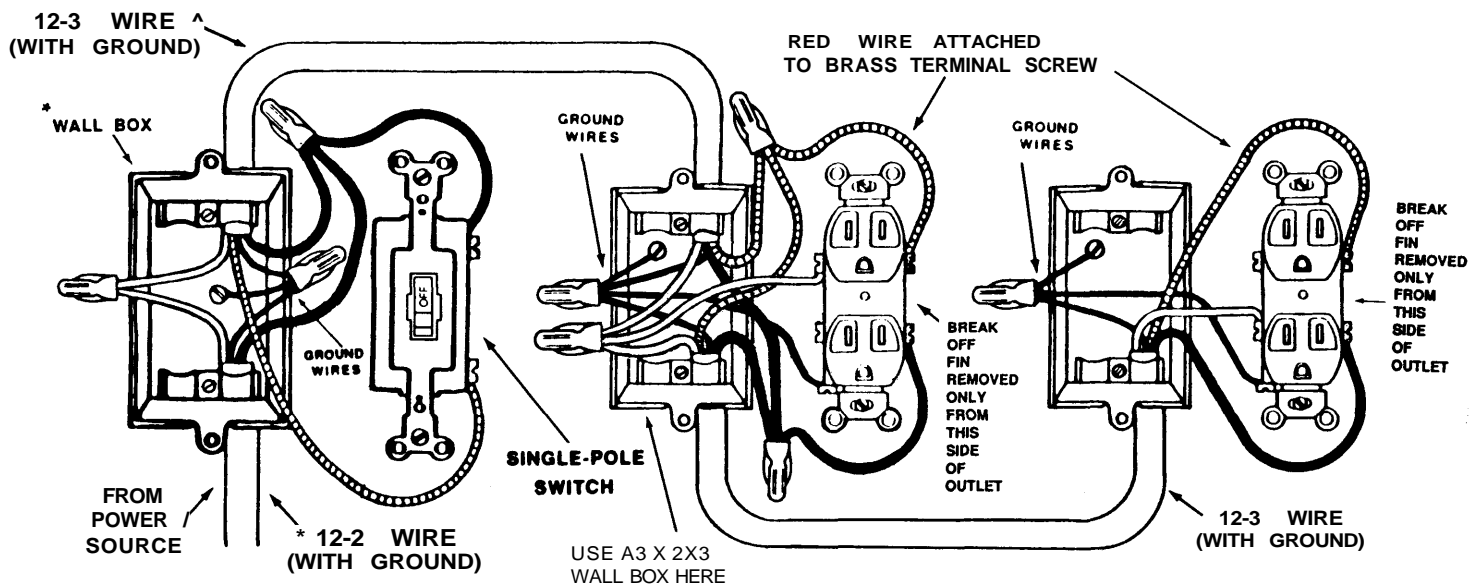

WIRING COLOR GUIDE	
	WHITE WIRE NEUTRAL
	BLACK WIRE HOT
	RED WIRE HOT
	BARE WIRE GROUND WIRE

THE SWITCH CONTROLS THE TOP HALF OF THE OUTLET S
THE BOTTOM HALF OF OUTLETS IS ALWAYS HOT.



* THE WIRING IN PLASTIC AND METAL BOXES IS THE SAME. EXCEPT FOR THE GROUND WIRE, THE GROUND WIRE ATTACHES TO THE METAL BOXES, IN PLASTIC IT CONNECTS TO THE METAL TAB PROVIDED INSIDE THE BOX. SEE PAGE 647 FOR MORE ON HOW THE GROUND WIRE WORKS IN PLASTIC BOXES.

THE PICTURE BELOW SHOWS HOW THE POWER SUPPLY FROM THE BREAKER BOX GOES TO TWO DIFFERENT JUNCTION BOXES, AND GOES IN TWO DIFFERENT DIRECTIONS.

WIRING COLOR GUIDE		
	WHITE WIRE	neutral
	BLACK WIRE	hot
	RED WIRE	hot
	BARE WIRE	ground wire

WIRE NUT GUIDE	
	USE RED WIRE NUTS WHERE WIRE NUTS ARE USED ON THIS PAGE INCLUDING GROUND WIRES
NUT	

* ON THIS PAGE WE SHOW USING METAL WALL AND METAL CEILING BOXES THE WIRING IN PLASTIC AND METAL BOXES IS THE SAME. EXCEPT FOR THE GROUND WIRE. THE GROUND WIRE ATTACHES TO THE METAL BOXES, IN PLASTIC IT DOES NOT, SEE PAGE 6 AND 7 FOR MORE ON HOW THE GROUND WIRE WORKS IN PLASTIC BOXES.

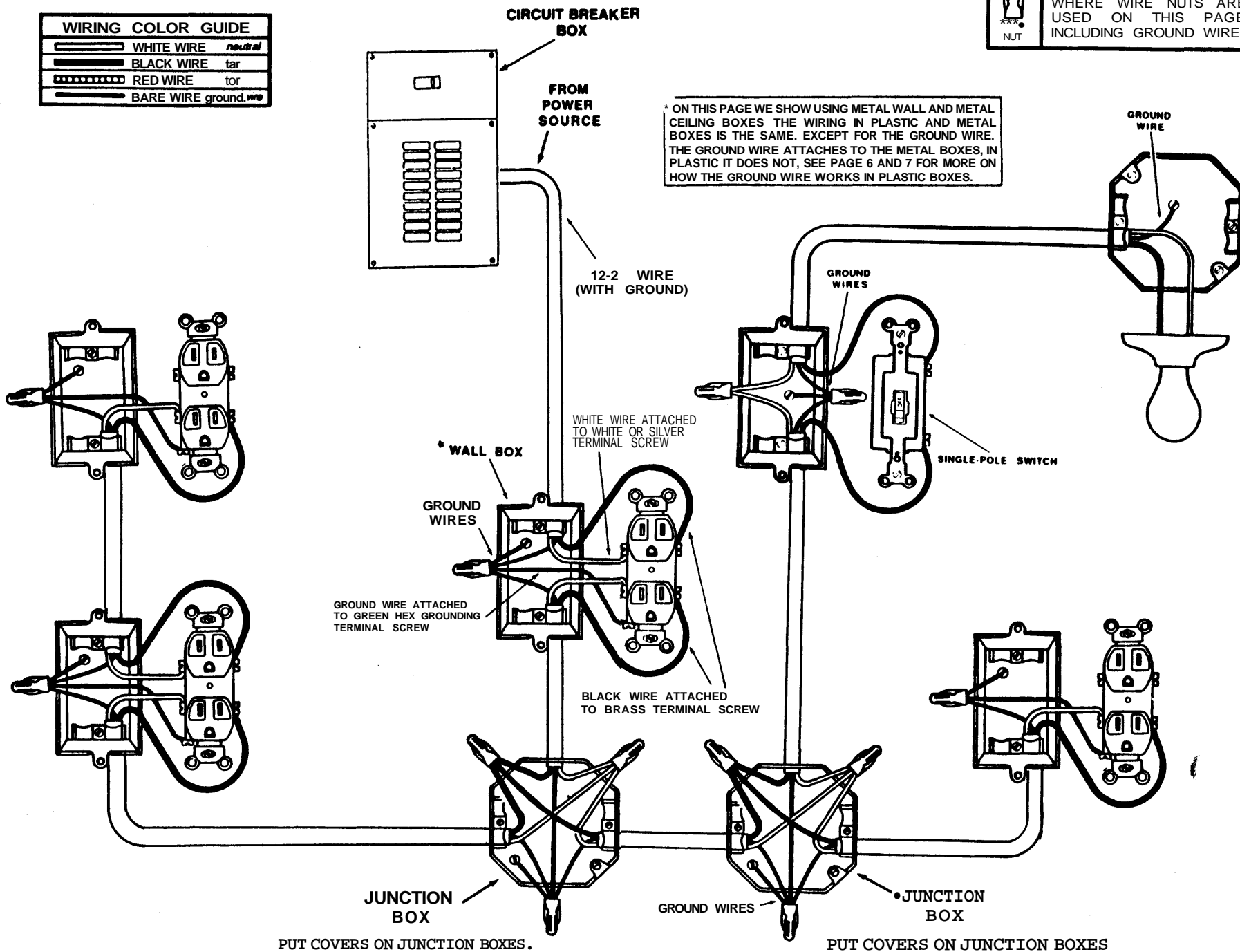

How the Home Electrical System Works

ALL ABOUT GROUND FAULT CIRCUIT INTERRUPTERS (GFCI)

GROUND FAULT PROTECTION IS A MUST WHEREVER ELECTRICITY IS USED NEAR WATER

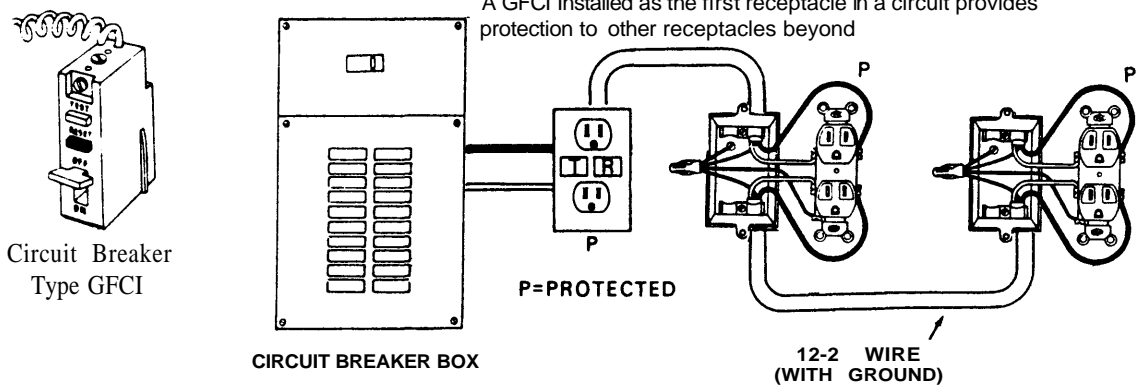

1. THE GFCI'S TURN OFF POWER IN 1/40 OF A SECOND TO PROTECT PEOPLE FROM SHOCK HAZARDS.
2. THE ELECTRICAL CODE REQUIRES GFCI PROTECTION IN AND AROUND THE HOME. CHECK WITH ELECTRICAL INSPECTORS FOR MORE ON THIS.
3. THE MOST USED GFCI'S ARE THE CIRCUIT BREAKER AND THE OUTLET TYPE.

WIRING COLOR GUIDE	
	3 WHITE WIRE NEUTRAL
	BLACK WIRE HOT
	RED WIRE HOT
	BARE WIRE GROUND WIRE

HOW TO CHANGE A SINGLE POLE SWITCH TO A SWITCH AND OUTLET

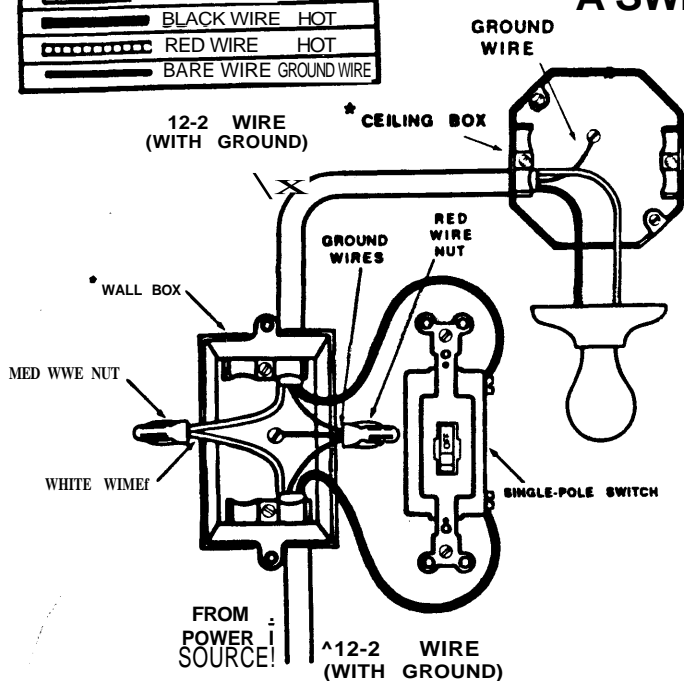

Before

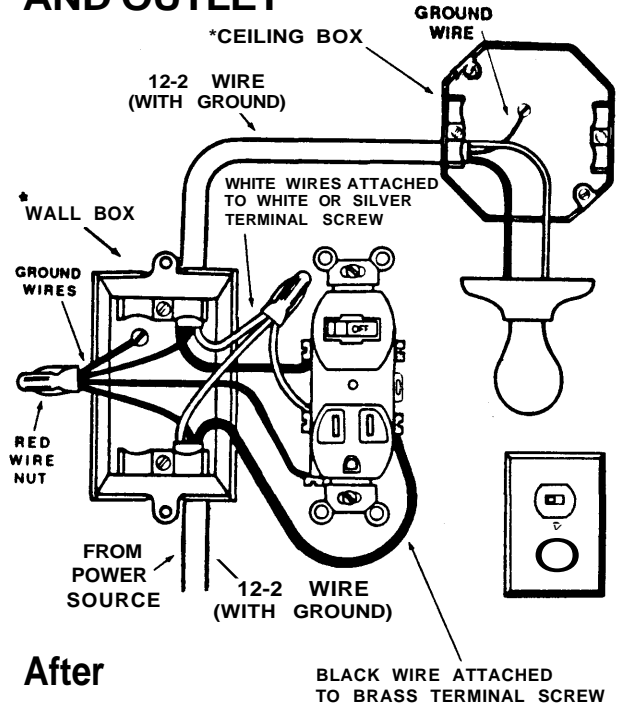

After

COMBINES A SINGLE-POLE SWITCH WITH AN OUTLET THAT IS ALWAYS HOT



WIRING COLOR GUIDE	
	WHITE WIRE <i>neutral</i>
	BLACK WIRE <i>hot</i>
	RED WIRE <i>hot</i>
	BARE WIRE <i>ground wire</i>

How To Wire Three-Way Switches With Switches Controlling One Light

WIRE NUT GUIDE	
	USE RED WIRE NUTS WHERE WIRE NUTS ARE USED ON THIS PAGE INCLUDING GROUND WIRES
	USE WHITE WIRE NUTS WHERE WIRE NUTS ARE USED ON THIS PAGE INCLUDING GROUND WIRES

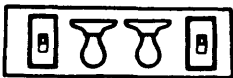
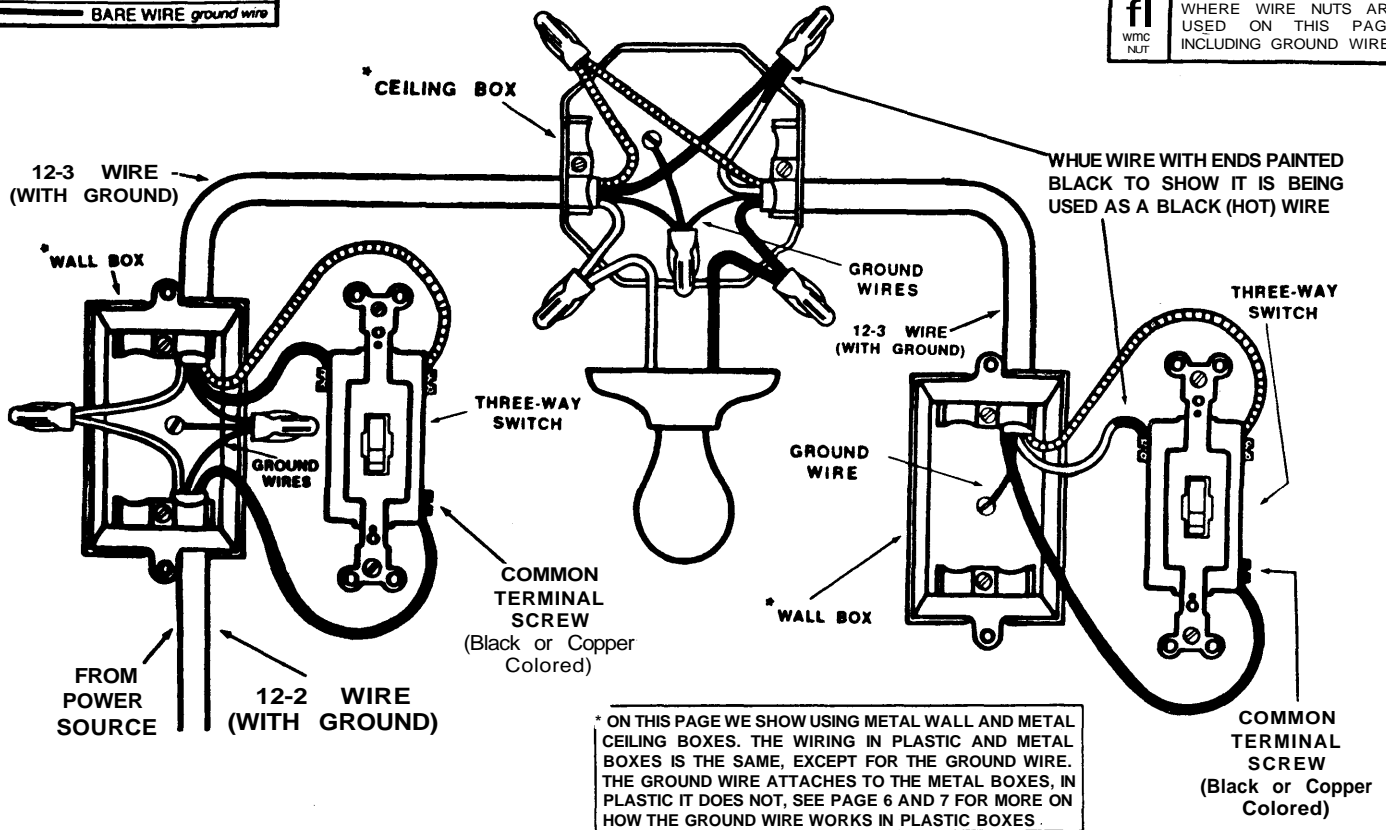

WIRING COLOR GUIDE	
	WHITE WIRE <i>neutral</i>
	BLACK WIRE <i>hot</i>
	RED WIRE <i>hot</i>
	BARE WIRE <i>ground wire</i>

How to Wire Three-Way Switches With Switches Controlling Two Lights

WIRE NUT GUIDE	
	USE RED WIRE NUTS WHERE WIRE NUTS ARE USED ON THIS PAGE INCLUDING GROUND WIRES
	USE WHITE WIRE NUTS WHERE WIRE NUTS ARE USED ON THIS PAGE INCLUDING GROUND WIRES

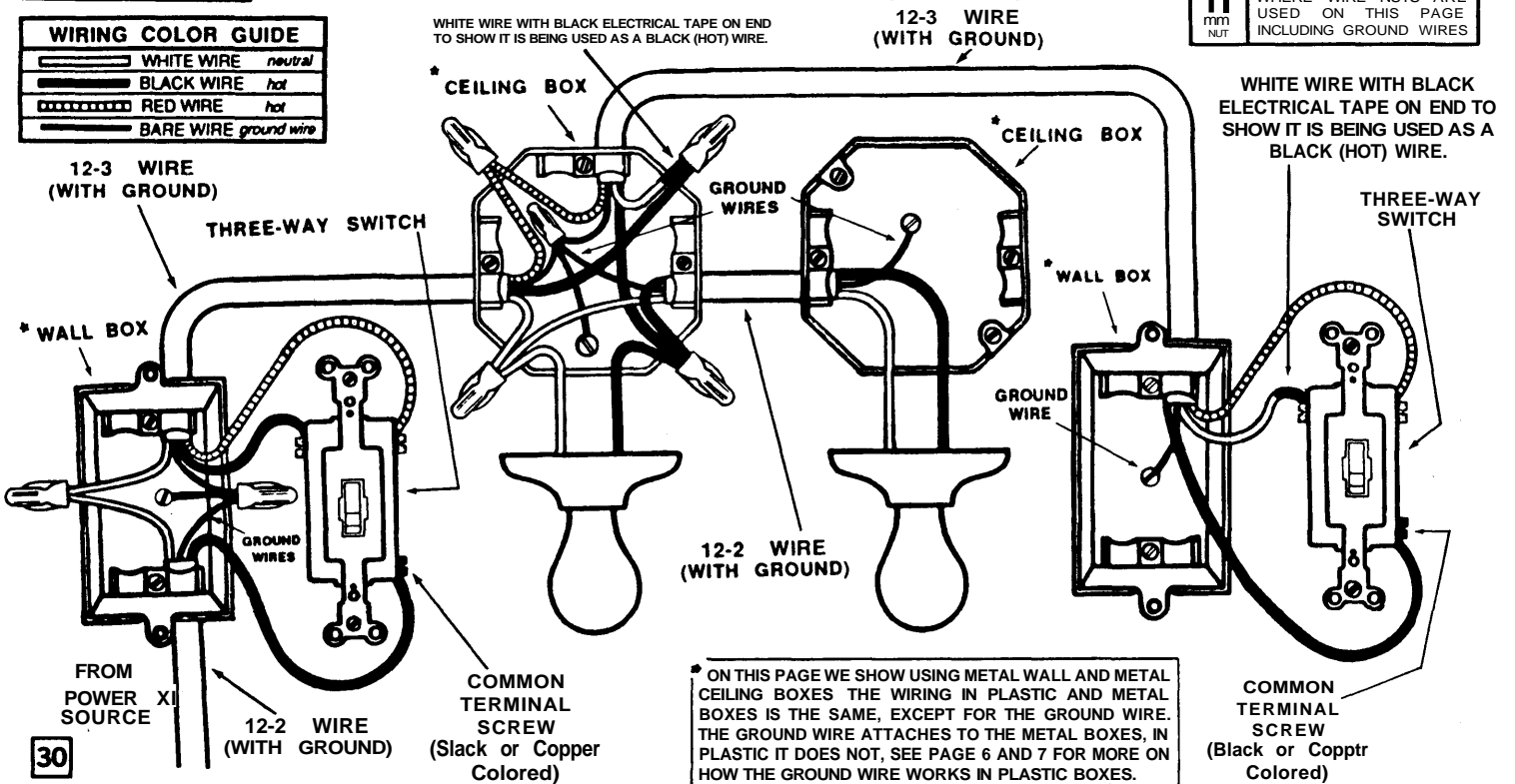

WIRING COLOR GUIDE	
	WHITE WIRE NEUTRAL
	BLACK WIRE HOT
	RED WIRE HOT
	BARE WIRE GROUND WIRE

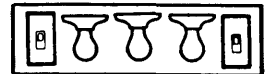

How to Wire Three-Way Switches With Switches Controlling Three Lights

WIRE NUT GUIDE	
	USE RED WIRE NUTS WHERE WIRE NUTS ARE USED ON THIS PAGE INCLUDING GROUND WIRES

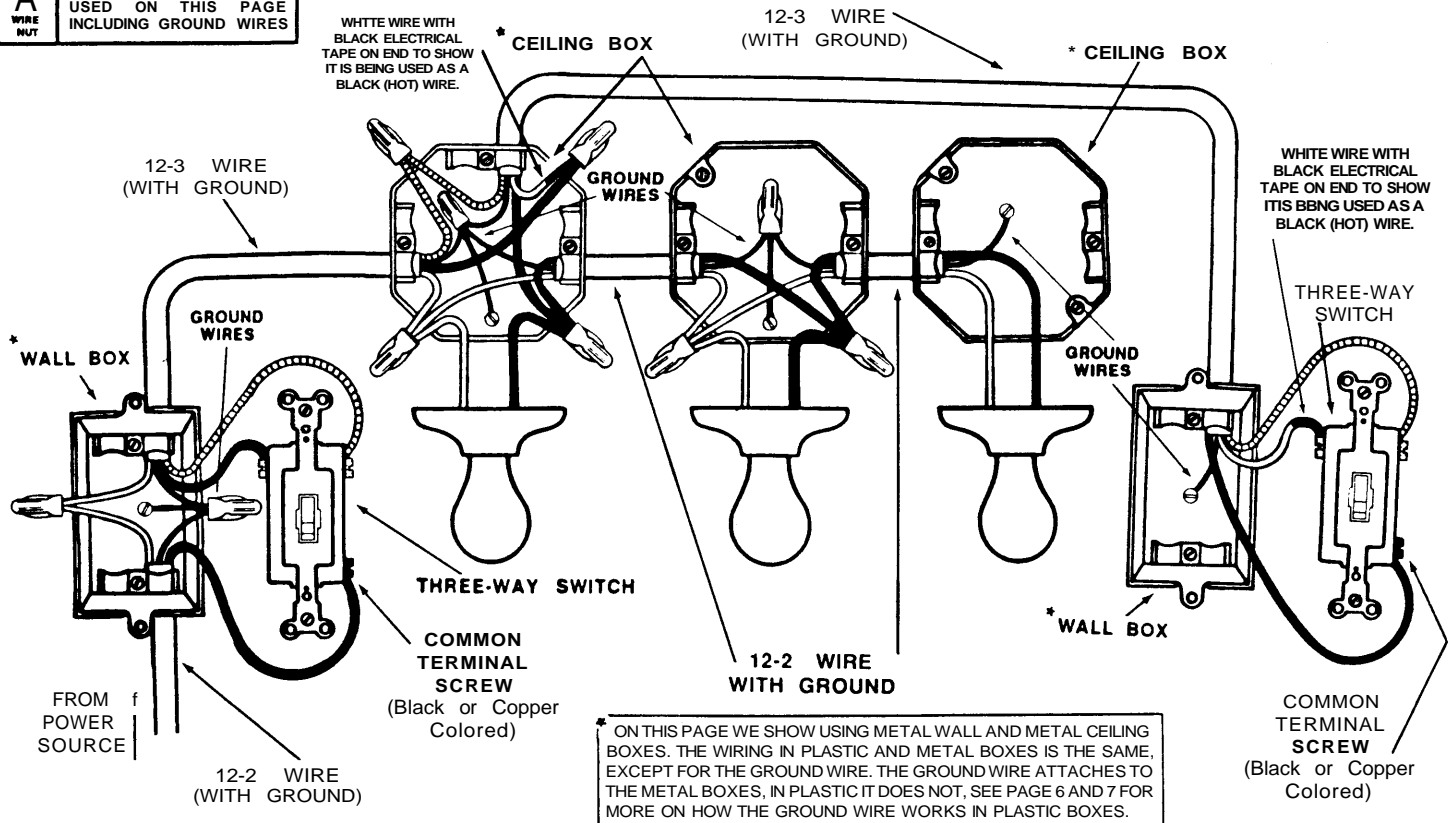

WIRING COLOR GUIDE	
	WHITE WIRE NEUTRAL
	BLACK WIRE HOT
	RED WIRE HOT
	BARE WIRE GROUND WIRE



How to Wire Three-Way Switches With Switches Controlling Four Lights

WIRE NUT GUIDE	
	USE RED WIRE NUTS WHERE WIRE NUTS ARE USED ON THIS PAGE INCLUDING GROUND WIRES

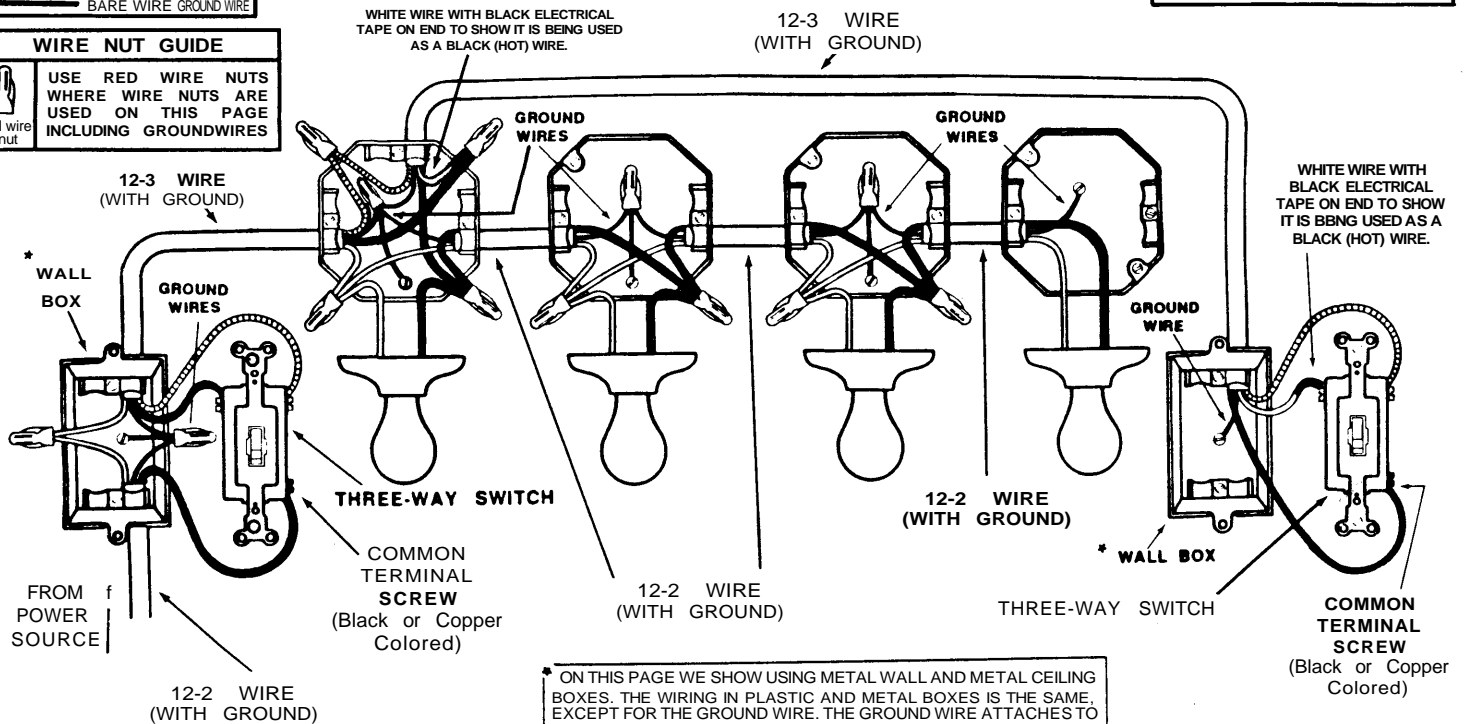



WIRING COLOR GUIDE	
	WHITE WIRE NEUTRAL
	BLACK WIRE HOT
	RED WIRE HOT
	BARE WIRE GROUND WIRE

How To Wire Three-Way Switches With Switches Controlling One Light

WIRE NUT GUIDE	
	USE RED WIRE NUTS WHERE WIRE NUTS ARE USED ON THIS PAGE INCLUDING GROUND WIRES

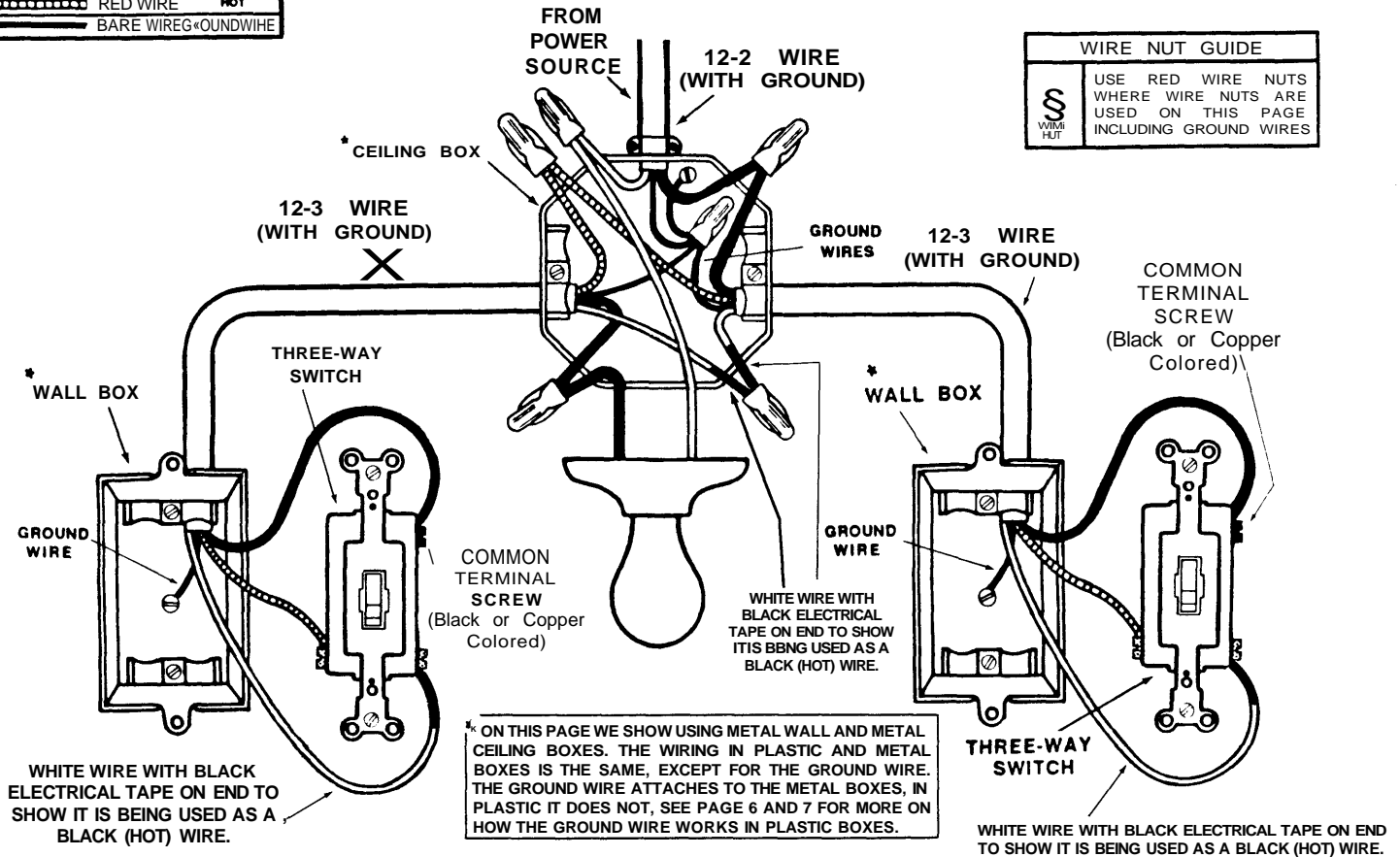

How to Wire Three-Way Switches With Switches Controlling Two Lights

WIRING COLOR GUIDE	
	WHITE WIRE neutral
	BLACK WIRE hot
	RED WIRE hot
	BARE WIRE ground wire

WIRE NUT GUIDE	
	USE RED WIRE NUTS WHERE WIRE NUTS ARE USED ON THIS PAGE INCLUDING GROUNDWIRES

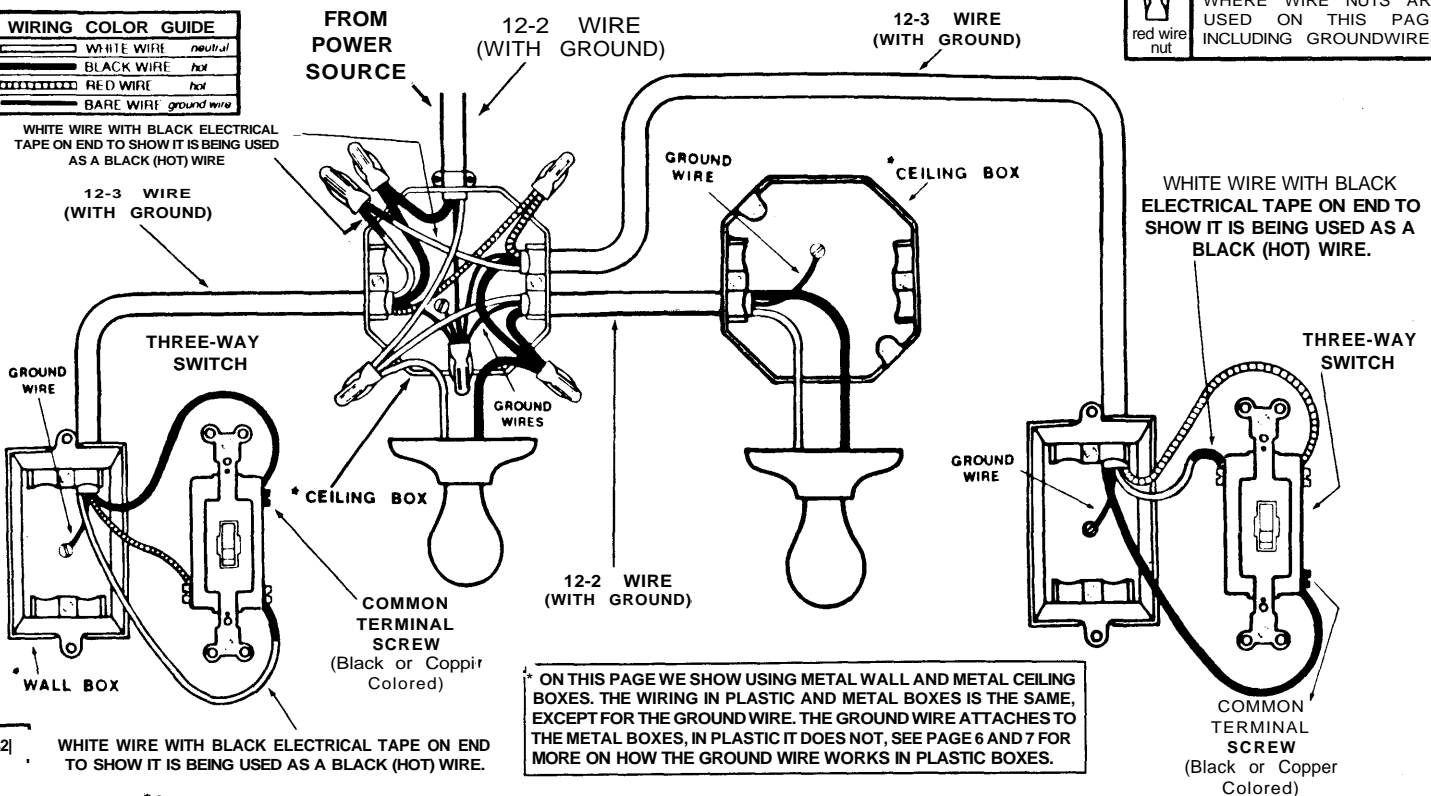



WIRING COLOR GUIDE	
	WHITE WIRE <i>neutral</i>
	BLACK WIRE <i>hot</i>
	RED WIRE <i>hot</i>
	BARE WIRE <i>ground wire</i>

How To Wire Three-Way Switches With Switches Controlling Three Lights

WIRE NUT GUIDE	
	USE RED WIRE NUTS WHERE WIRE NUTS ARE USED ON THIS PAGE INCLUDING GROUND WIRES

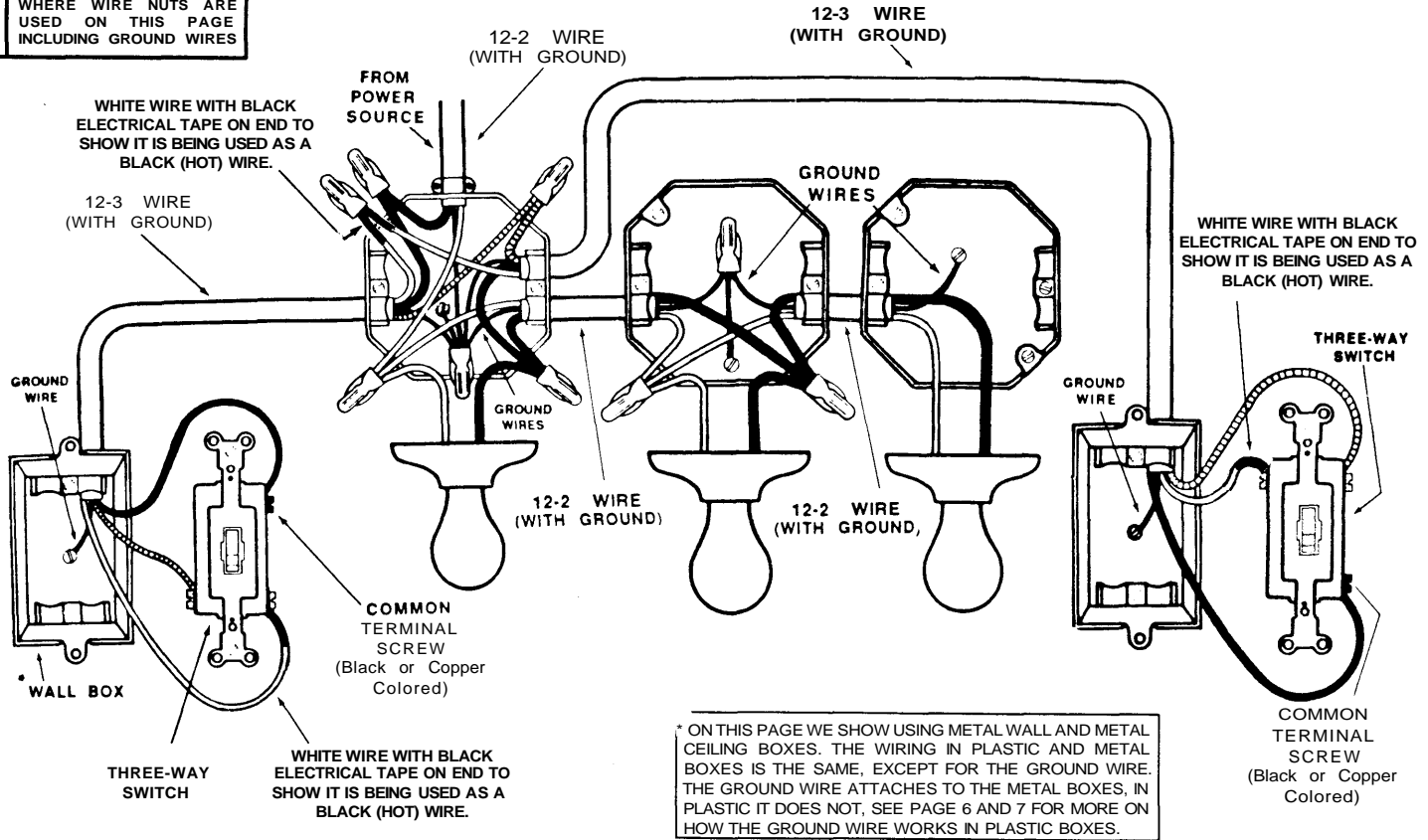

WIRING COLOR GUIDE	
	WHITE WIRE <i>neutral</i>
	BLACK WIRE <i>hot</i>
	RED WIRE <i>hot</i>
	BARE WIRE <i>ground wire</i>

How to Wire Three-Way Switches With Switches Controlling Four Lights



WIRE NUT GUIDE	
	USE RED WIRE NUTS WHERE WIRE NUTS ARE USED ON THIS PAGE INCLUDING GROUND WIRES

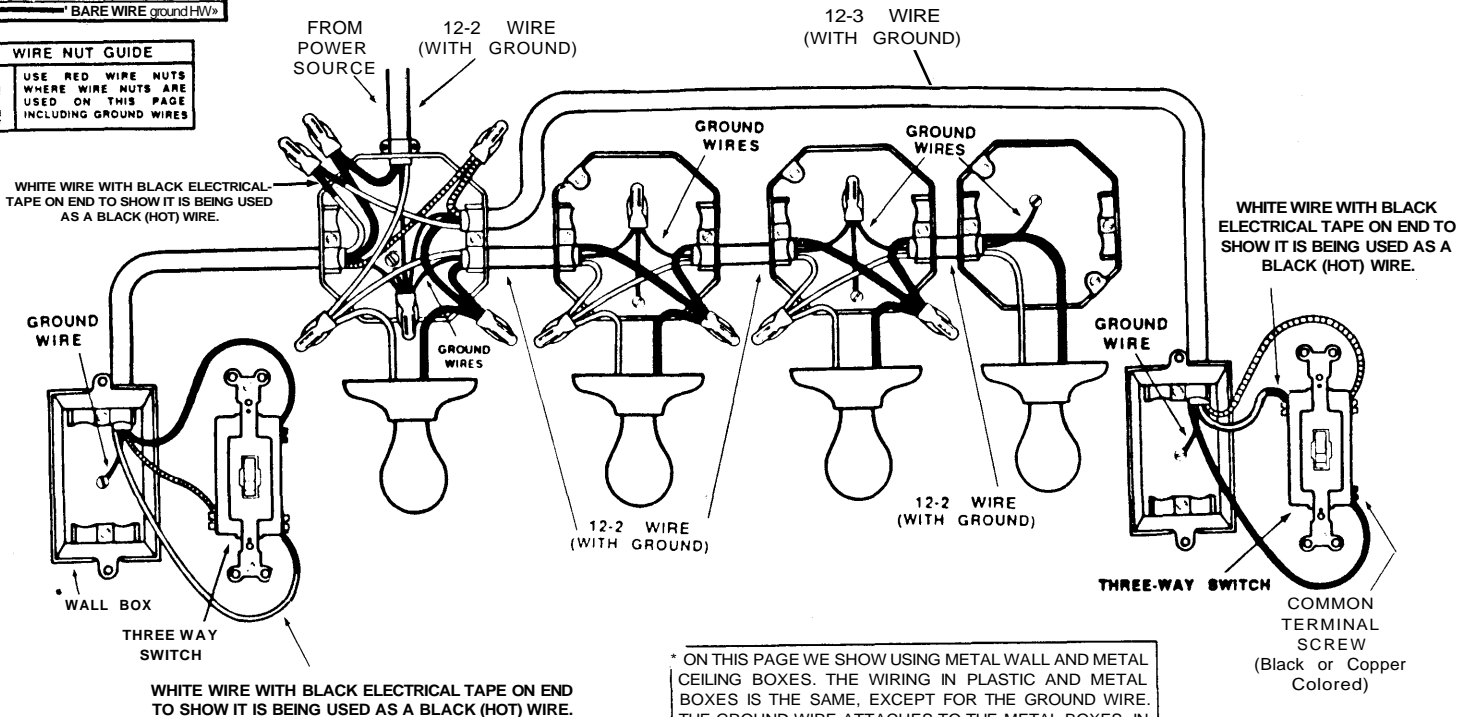



WIRING COLOR GUIDE		
1	WMITFWJRF	neutral
—	BLACK WIRE	hot
—	RED WIRE	hot
—	BARE WIRE	ground wire

How to Wire Three-Way Switches

With Switches Controlling One Light

WIRE NUT GUIDE	
fl red wire nut	USE RED WIRE NUTS WHERE WIRE NUTS ARE USED ON THIS PAGE INCLUDING GROUNDWIRES

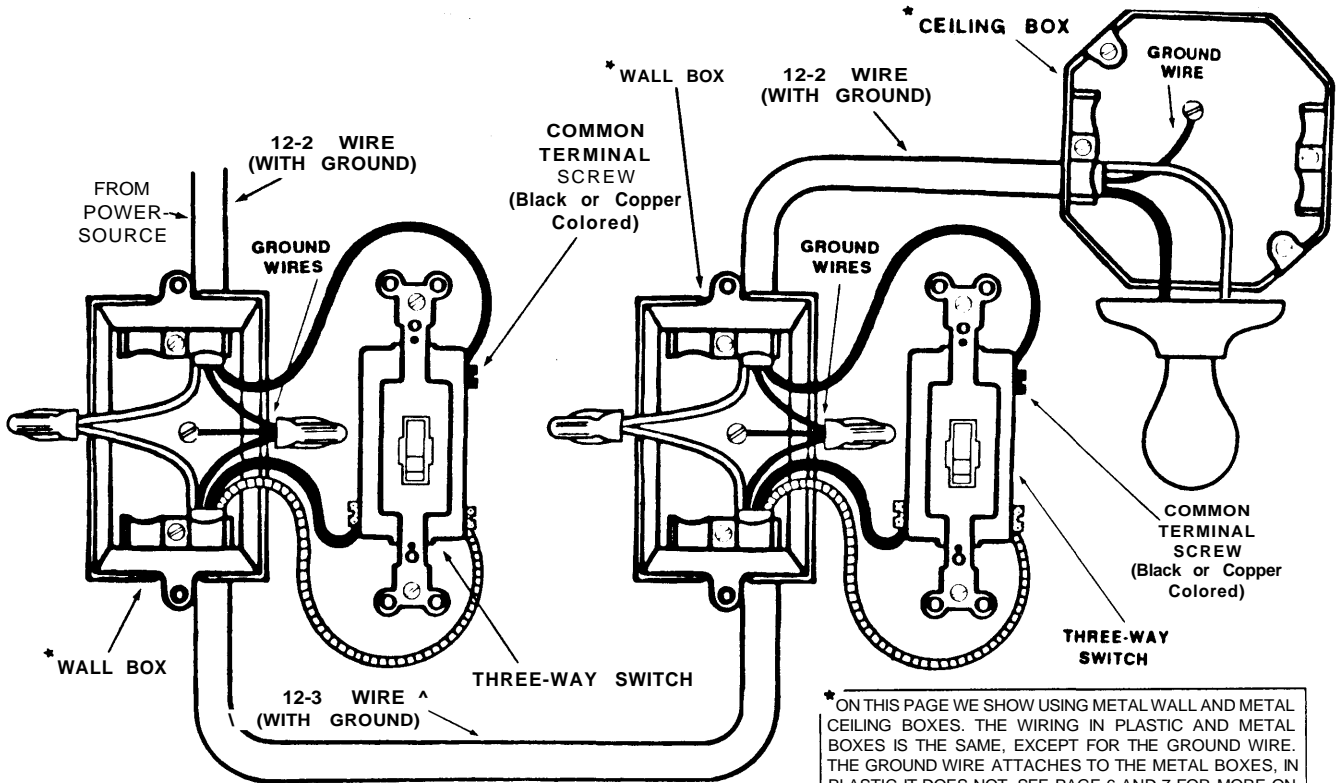

* ON THIS PAGE WE SHOW USING METAL WALL AND METAL CEILING BOXES. THE WIRING IN PLASTIC AND METAL BOXES IS THE SAME, EXCEPT FOR THE GROUND WIRE. THE GROUND WIRE ATTACHES TO THE METAL BOXES, IN PLASTIC IT DOES NOT, SEE PAGE 6 AND 7 FOR MORE ON HOW THE GROUND WIRE WORKS IN PLASTIC BOXES.



WIRING COLOR GUIDE		
—	WHITE WIRE	NEUTRAL
—	BLACK WIRE	HOT
—	RED WIRE	HOT
—	BARE WIRE	GROUND WIRE

WIRE NUT GUIDE	
fl WIRE NUT	USE RED WIRE NUTS WHERE WIRE NUTS ARE USED ON THIS PAGE INCLUDING GROUND WIRES

How To Wire Three-Way Switches

With Switches Controlling Two Lights

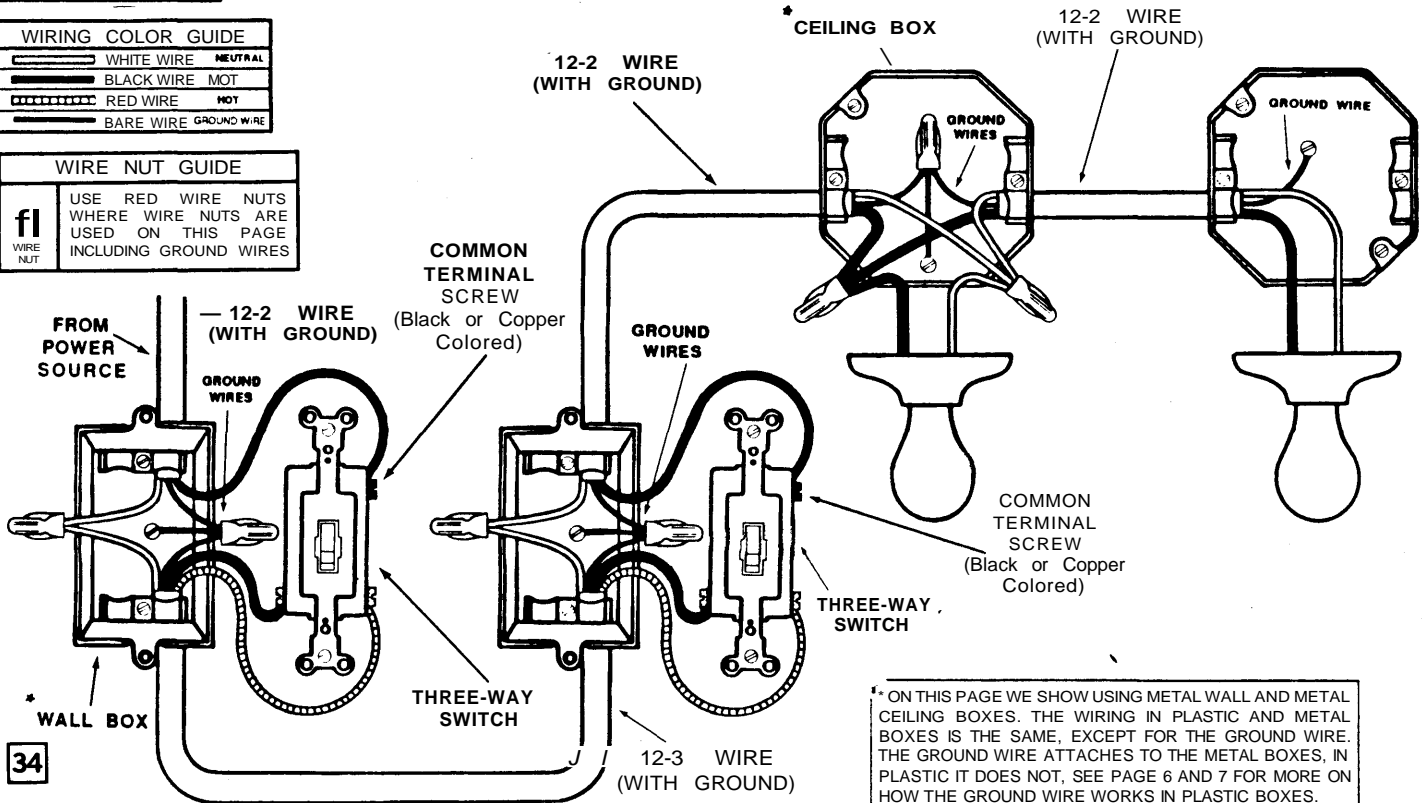

* ON THIS PAGE WE SHOW USING METAL WALL AND METAL CEILING BOXES. THE WIRING IN PLASTIC AND METAL BOXES IS THE SAME, EXCEPT FOR THE GROUND WIRE. THE GROUND WIRE ATTACHES TO THE METAL BOXES, IN PLASTIC IT DOES NOT, SEE PAGE 6 AND 7 FOR MORE ON HOW THE GROUND WIRE WORKS IN PLASTIC BOXES.

WIRING COLOR GUIDE	
	WHITE WIRE <i>neutral</i>
	BLACK WIRE <i>hot</i>
	RED WIRE <i>hot</i>
	BARE WIRE <i>ground</i>

WIRE NUT GUIDE	
	USE RED WIRE NUTS WHERE WIRE NUTS ARE USED ON THIS PAGE INCLUDING GROUNDWIRES

How To Wire Three-Way Switches

With Switches Controlling Three Lights

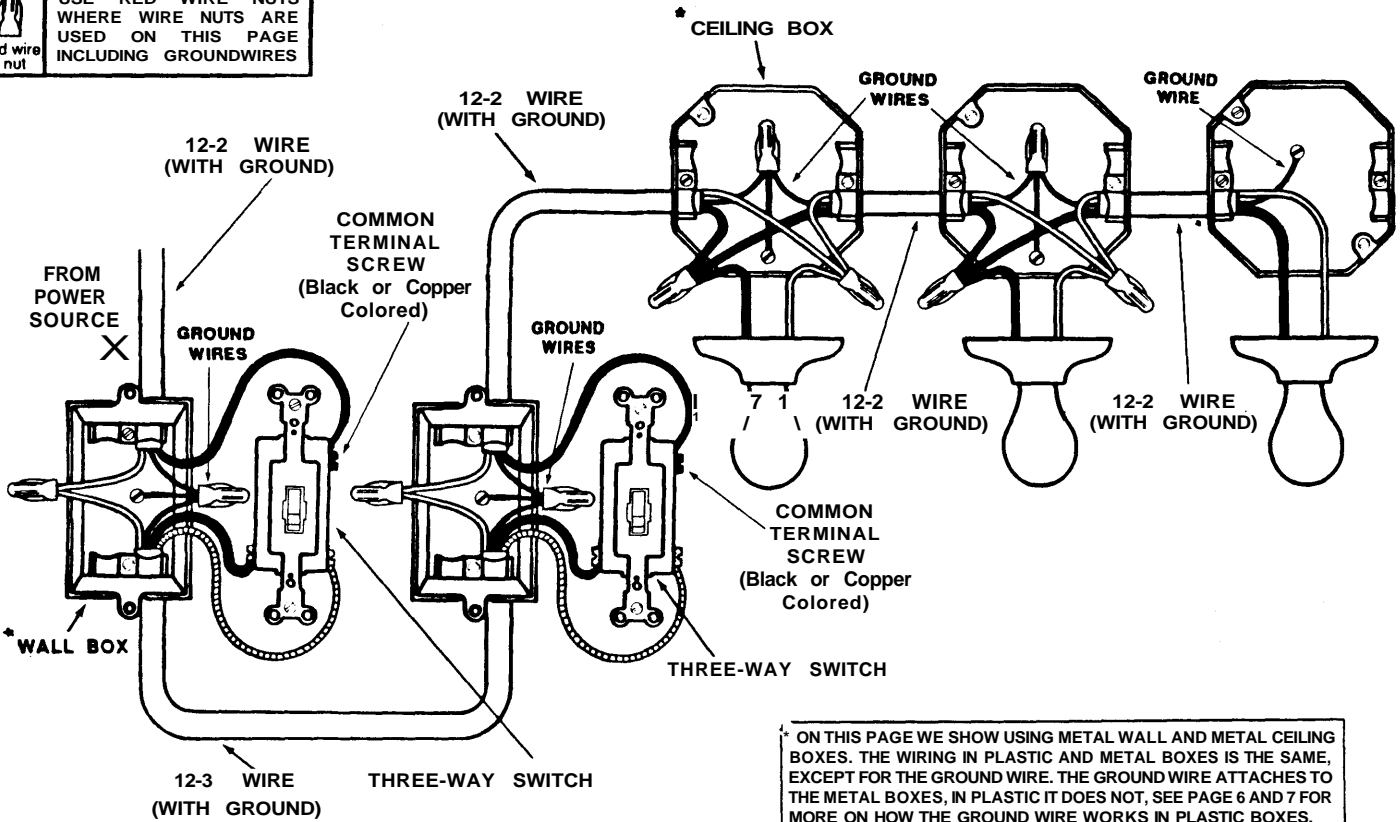

ON THIS PAGE WE SHOW USING METAL WALL AND METAL CEILING BOXES. THE WIRING IN PLASTIC AND METAL BOXES IS THE SAME, EXCEPT FOR THE GROUND WIRE. THE GROUND WIRE ATTACHES TO THE METAL BOXES, IN PLASTIC IT DOES NOT, SEE PAGE 6 AND 7 FOR MORE ON HOW THE GROUND WIRE WORKS IN PLASTIC BOXES.

WIRING COLOR GUIDE	
	WHITE WIRE <i>neutral</i>
	BLACK WIRE <i>hot</i>
	RED WIRE: <i>hot</i>
	BARE WIRE <i>ground</i>

WIRE NUT GUIDE	
4	USE RED WIRE NUTS WHERE WIRE NUTS ARE USED ON THIS PAGE INCLUDING GROUNDWIRES

How to Wire Three-Way Switches

With Switches Controlling Four Lights

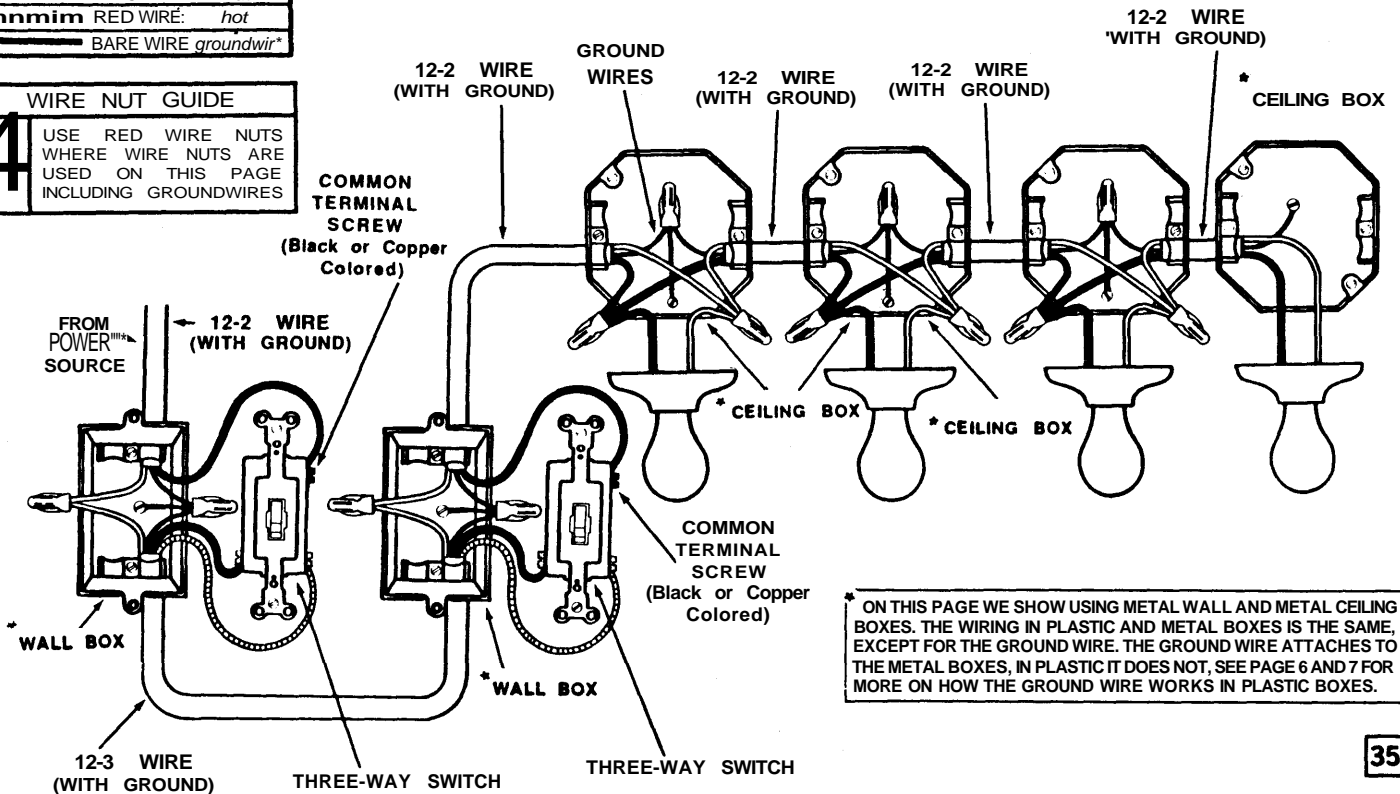
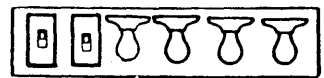

ON THIS PAGE WE SHOW USING METAL WALL AND METAL CEILING BOXES. THE WIRING IN PLASTIC AND METAL BOXES IS THE SAME, EXCEPT FOR THE GROUND WIRE. THE GROUND WIRE ATTACHES TO THE METAL BOXES, IN PLASTIC IT DOES NOT, SEE PAGE 6 AND 7 FOR MORE ON HOW THE GROUND WIRE WORKS IN PLASTIC BOXES.



How To Wire Three-Way Switches

With Switches Controlling One Light

WIRE NUT GUIDE	
a WIRE NUT	USE RED WIRE NUTS WHERE WIRE NUTS ARE USED ON THIS PAGE INCLUDING GROUND WIRES

WIRING COLOR GUIDE	
	WHITE WIRE NEUTRAL
	BLACK WIRE HOT
	RED WIRE HOT
	BARE WIRE GROUND WIRE

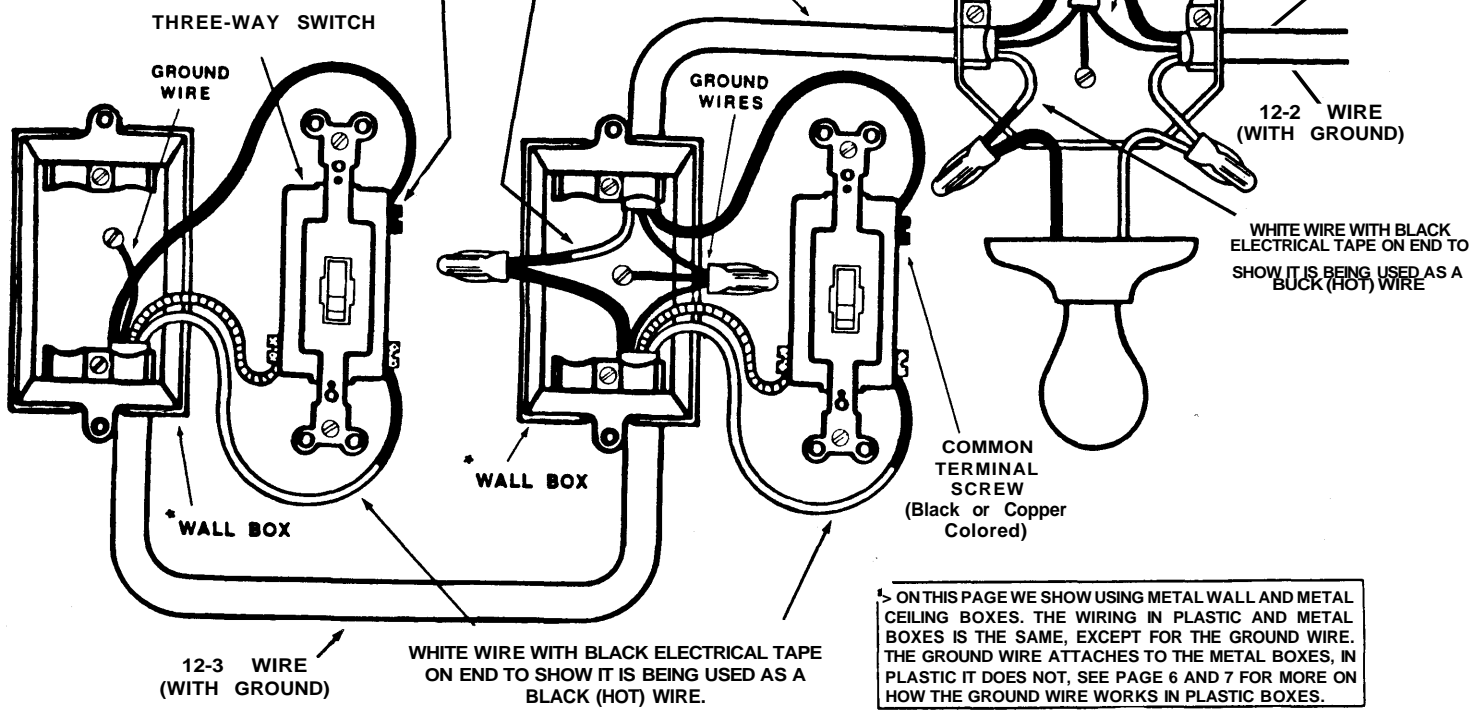

* ON THIS PAGE WE SHOW USING METAL WALL AND METAL CEILING BOXES. THE WIRING IN PLASTIC AND METAL BOXES IS THE SAME, EXCEPT FOR THE GROUND WIRE. THE GROUND WIRE ATTACHES TO THE METAL BOXES, IN PLASTIC IT DOES NOT, SEE PAGE 6 AND 7 FOR MORE ON HOW THE GROUND WIRE WORKS IN PLASTIC BOXES.



How to Wire Three-Way Switches

With Switches Controlling Two Lights

WIRE NUT GUIDE	
A WIRE NUT	USE MED WIRE NUTS WHERE WIRE NUTS ARE USED ON THIS PAGE INCLUDING GROUND WIRES

WIRING COLOR GUIDE	
	WHITE WIRE NEUTRAL
	BLACK WIRE HOT
	RED WIRE HOT
	BARE WIRE GROUND WIRE

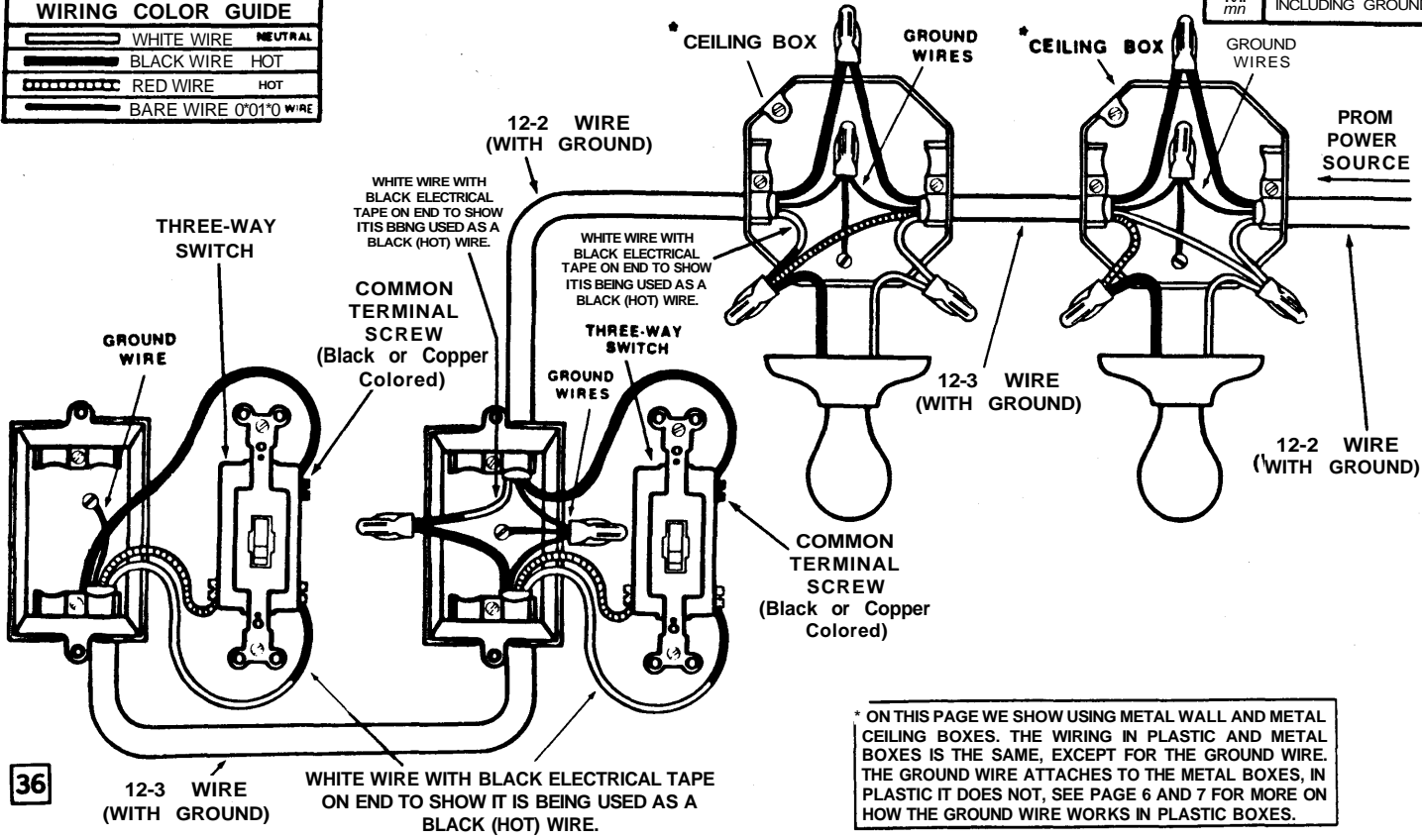

* ON THIS PAGE WE SHOW USING METAL WALL AND METAL CEILING BOXES. THE WIRING IN PLASTIC AND METAL BOXES IS THE SAME, EXCEPT FOR THE GROUND WIRE. THE GROUND WIRE ATTACHES TO THE METAL BOXES, IN PLASTIC IT DOES NOT, SEE PAGE 6 AND 7 FOR MORE ON HOW THE GROUND WIRE WORKS IN PLASTIC BOXES.

WIRING COLOR GUIDE	
	WHITE WIRE NEUTRAL
	BLACK WIRE HOT
	RED WIRE HOT
	BARE WIRE GROUND WIRE

WIRE NUT GUIDE	
	USE MED WIRE NUTS WHERE WIRE NUTS ARE USED ON THIS PAGE INCLUDING GROUND WIRES

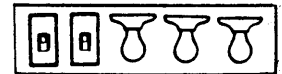

How To Wire Three-Way Switches With Switches Controlling Three Lights

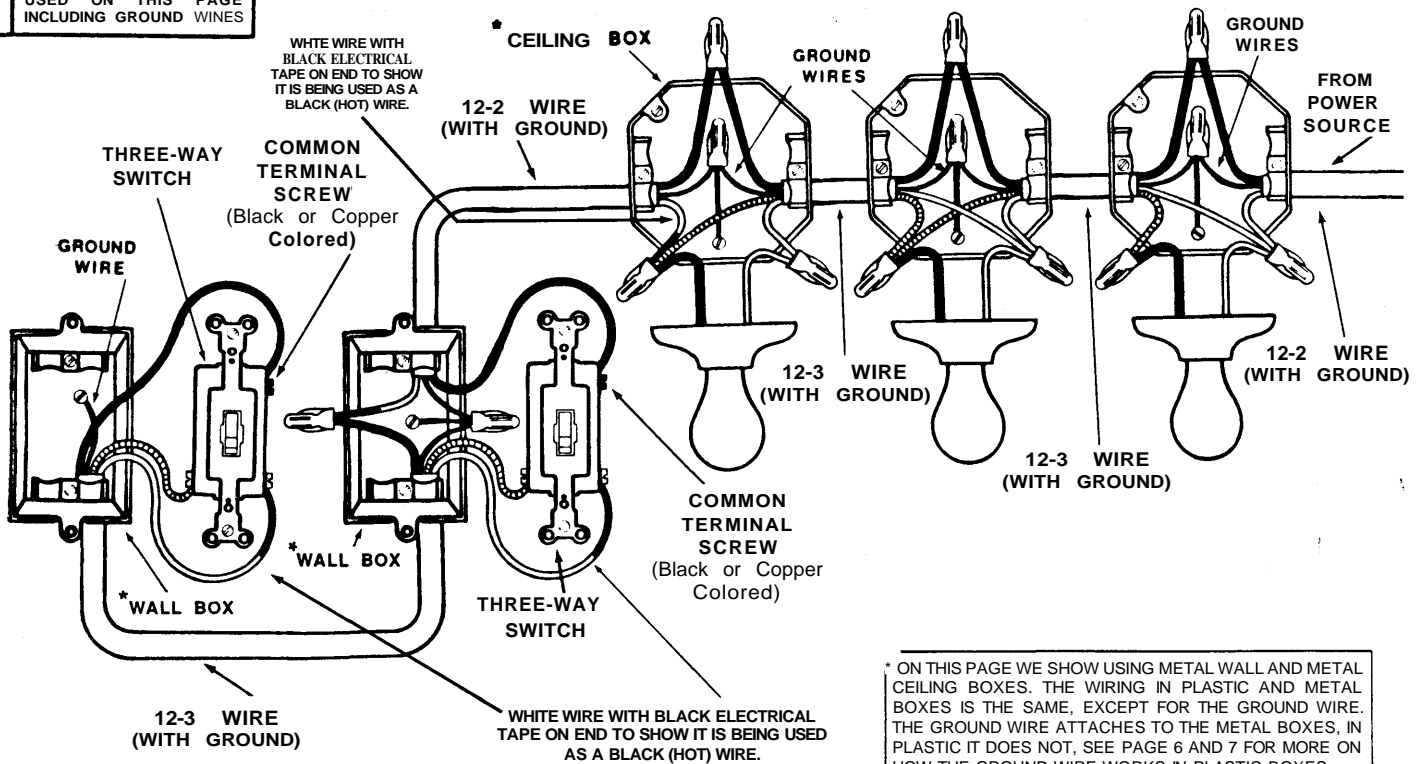

WIRING COLOR GUIDE	
	WHITE WIRE NEUTRAL
	BLACK WIRE HOT
	RED WIRE HOT
	BARE WIRE GROUND WIRE

WIRE NUT GUIDE	
	USE RED WIRE NUTS WHERE WIRE NUTS ARE USED ON THIS PAGE INCLUDING GROUND WIRES

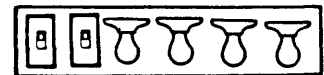

How to Wire Three-Way Switches With Switches Controlling Four Lights

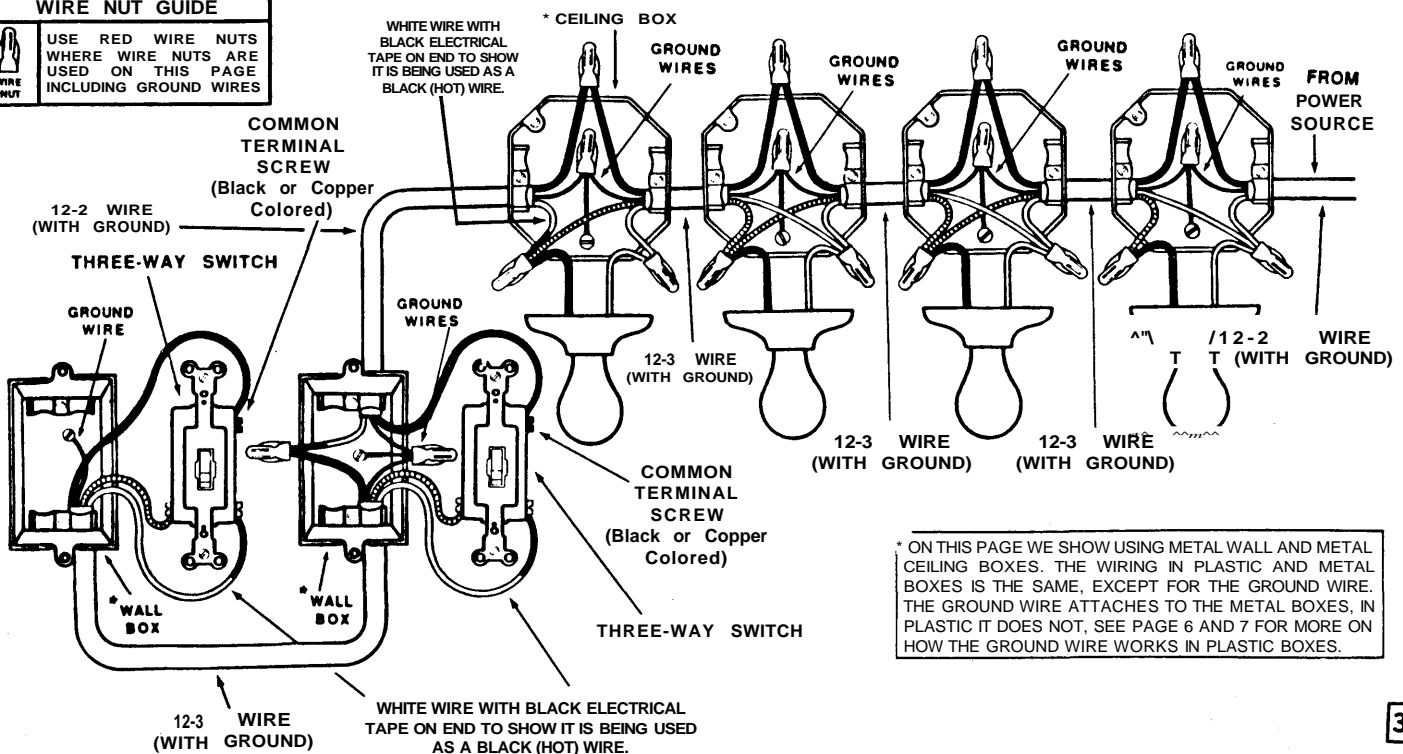



WIRING COLOR GUIDE	
	WHITE WIRE NEUTRAL
	BLACK WIRE HOT
	RED WIRE HOT
	BARE WIRE GROUND WIRE

How to Wire Single Pole Switch With Switch Controlling One Light

WIRE NUT GUIDE	
	USE RED WIRE NUTS WHERE WIRE NUTS ARE USED ON THIS PAGE INCLUDING GROUND WIRES

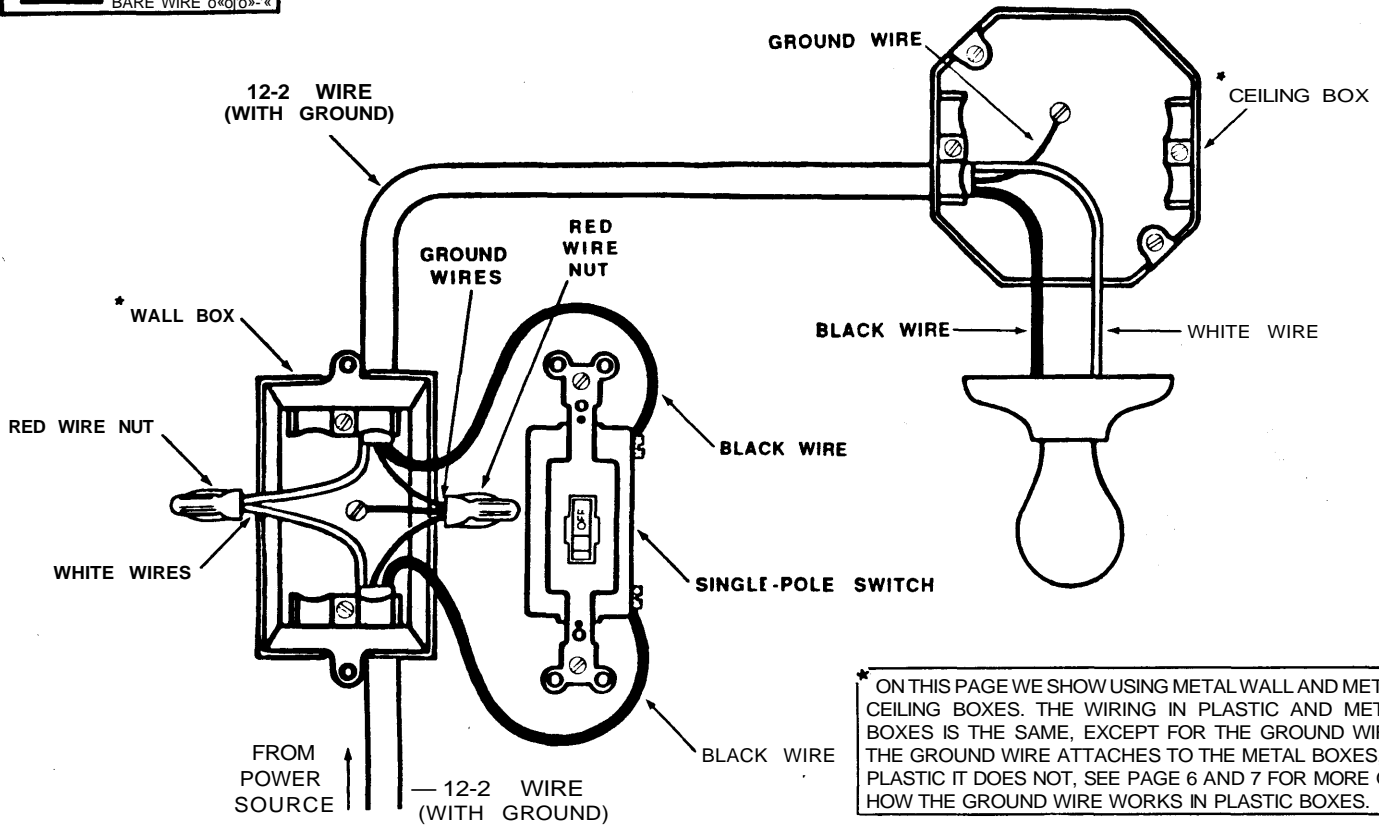

* ON THIS PAGE WE SHOW USING METAL WALL AND METAL CEILING BOXES. THE WIRING IN PLASTIC AND METAL BOXES IS THE SAME, EXCEPT FOR THE GROUND WIRE. THE GROUND WIRE ATTACHES TO THE METAL BOXES, IN PLASTIC IT DOES NOT, SEE PAGE 6 AND 7 FOR MORE ON HOW THE GROUND WIRE WORKS IN PLASTIC BOXES.

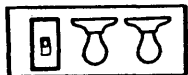

WIRING COLOR GUIDE	
	WHITE WIRE NEUTRAL
	BLACK WIRE HOT
	RED WIRE HOT
	BARE WIRE GROUND WIRE

How To Wire Single Pole Switch With Switch Controlling Two Lights

WIRE NUT GUIDE	
	USE RED WIRE NUTS WHERE WIRE NUTS ARE USED ON THIS PAGE INCLUDING GROUND WIRES

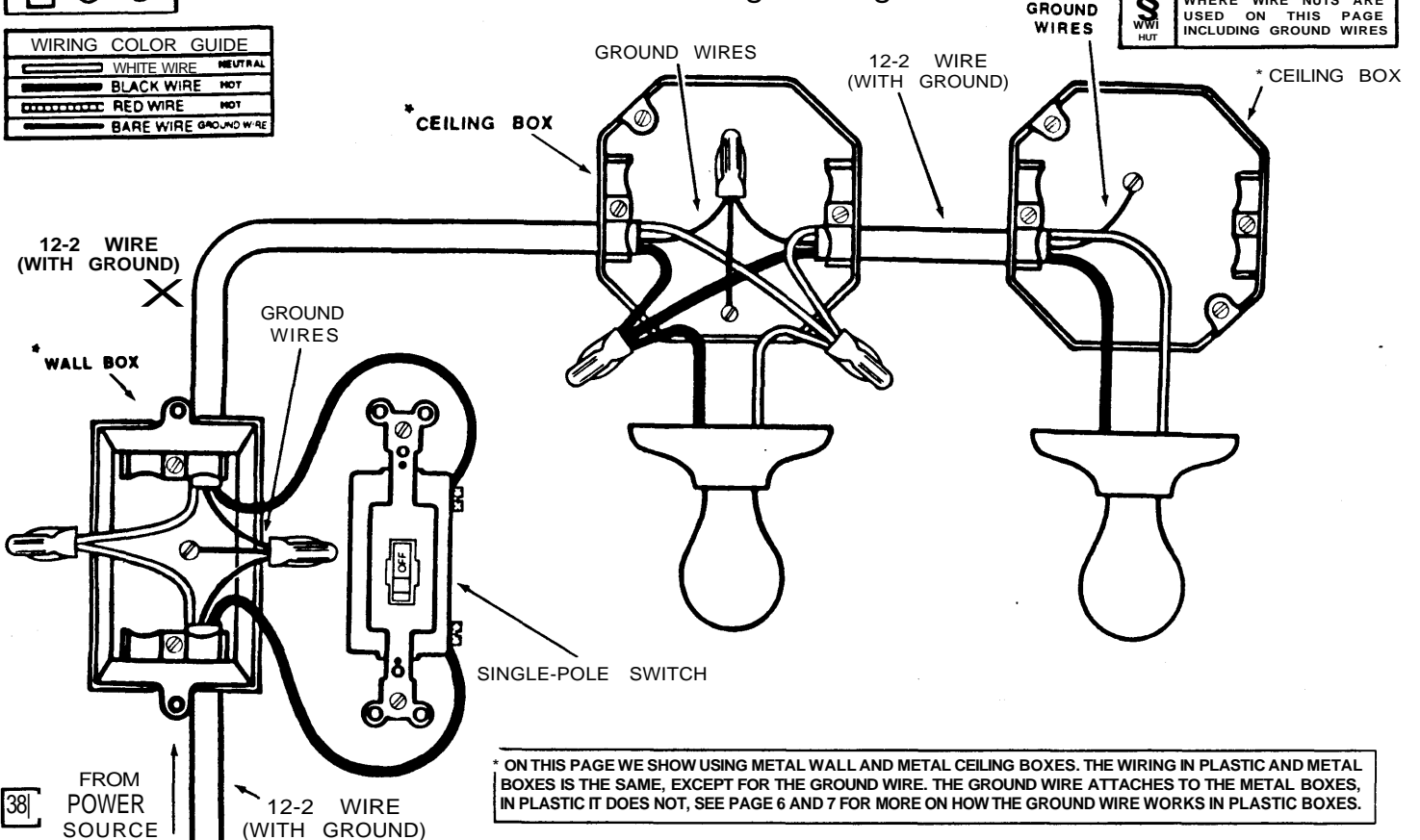

* ON THIS PAGE WE SHOW USING METAL WALL AND METAL CEILING BOXES. THE WIRING IN PLASTIC AND METAL BOXES IS THE SAME, EXCEPT FOR THE GROUND WIRE. THE GROUND WIRE ATTACHES TO THE METAL BOXES, IN PLASTIC IT DOES NOT, SEE PAGE 6 AND 7 FOR MORE ON HOW THE GROUND WIRE WORKS IN PLASTIC BOXES.

WIRING COLOR GUIDE	
	WHITE WIRE NEUTRAL
	BLACK WIRE HOT
	RED WIRE HOT
	BARE WIRE GROUND WIRE

WIRE NUT GUIDE	
	USE RED WIRE NUTS WHERE WIRE NUTS ARE USED ON THIS PAGE INCLUDING GROUND WIRES

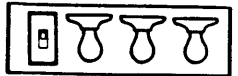

How to Wire Single Pole Switch

With Switch Controlling Three Lights

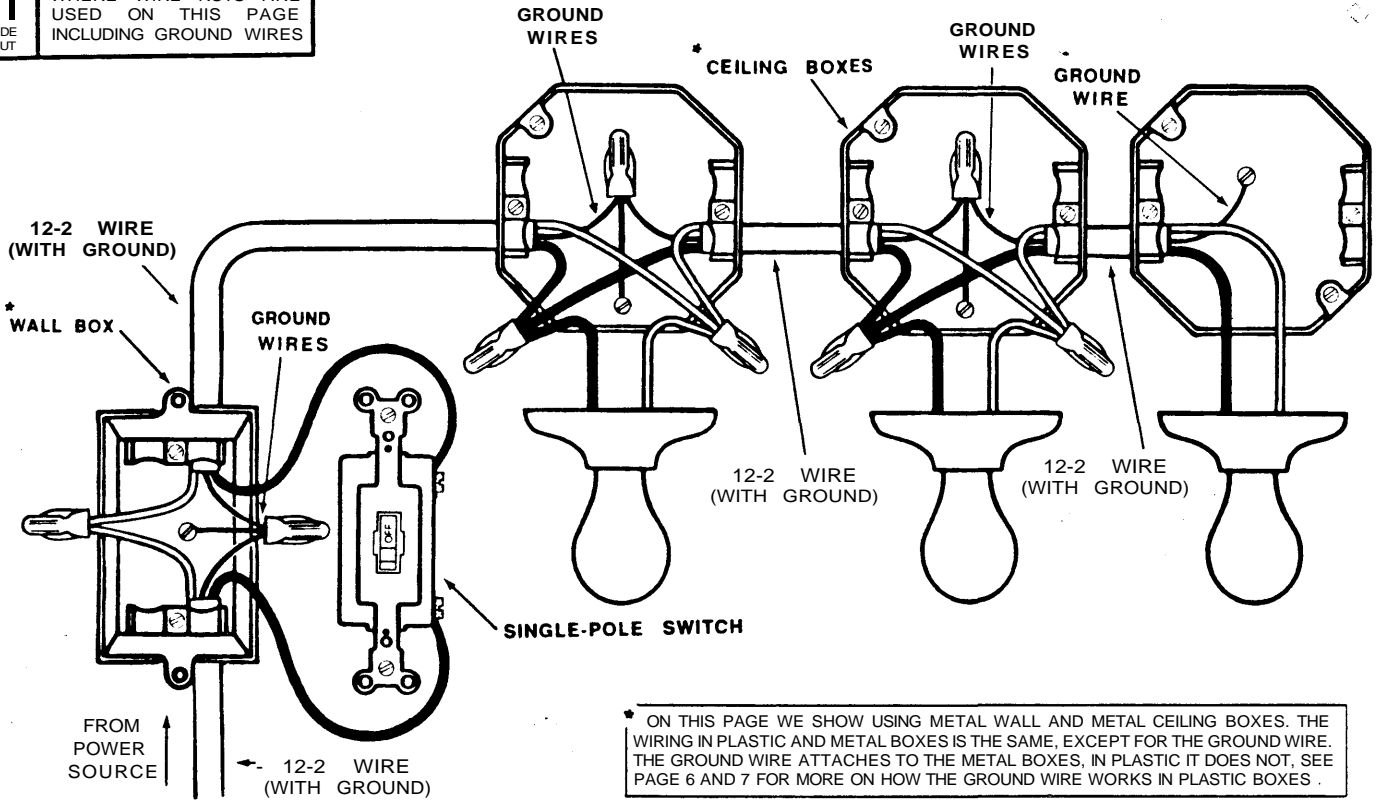

* ON THIS PAGE WE SHOW USING METAL WALL AND METAL CEILING BOXES. THE WIRING IN PLASTIC AND METAL BOXES IS THE SAME, EXCEPT FOR THE GROUND WIRE. THE GROUND WIRE ATTACHES TO THE METAL BOXES, IN PLASTIC IT DOES NOT, SEE PAGE 6 AND 7 FOR MORE ON HOW THE GROUND WIRE WORKS IN PLASTIC BOXES.

WIRING COLOR GUIDE	
	WHITE WIRE NEUTRAL
	BLACK WIRE HOT
	RED WIRE HOT
	BARE WIRE GROUND WIRE

WIRE NUT GUIDE	
	USE RED WIRE NUTS WHERE WIRE NUTS ARE USED ON THIS PAGE INCLUDING GROUND WIRES

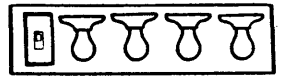

How To Wire Single Pole Switch

With Switch Controlling Four Lights

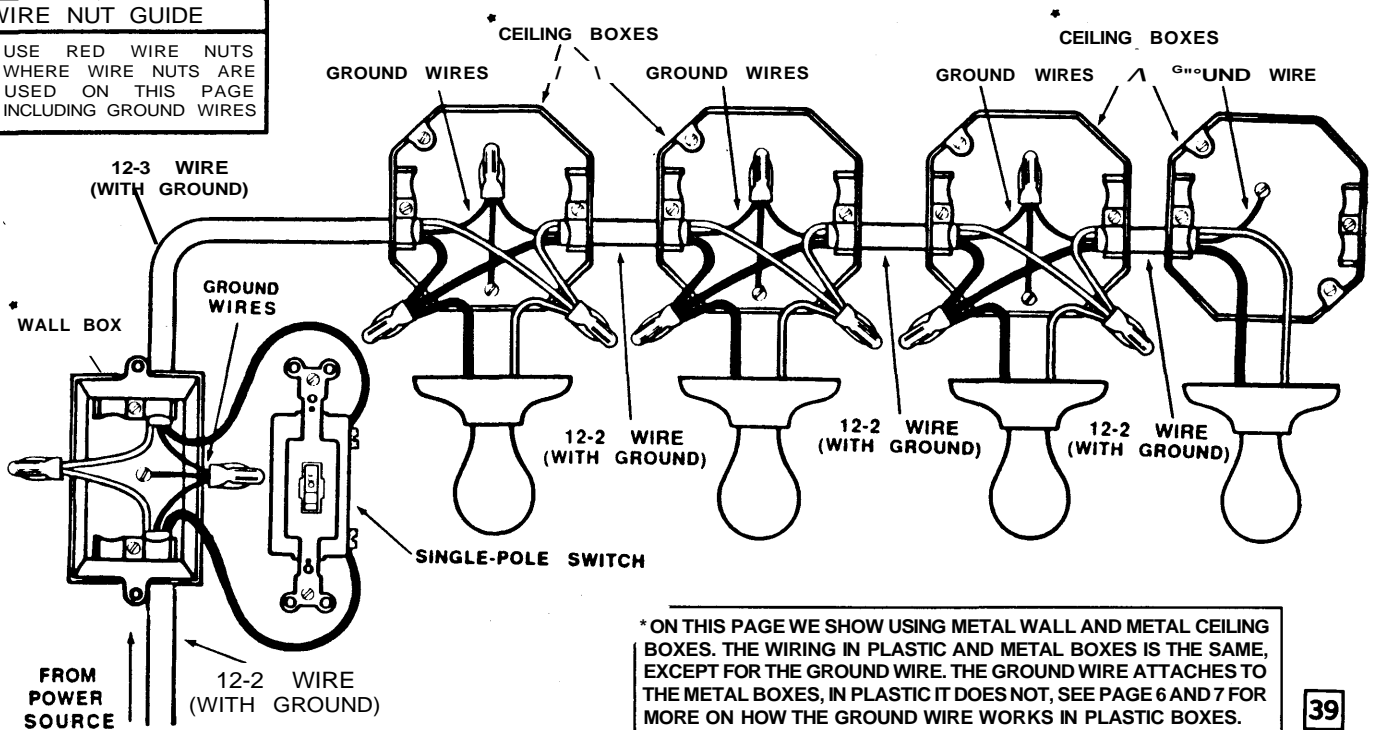

* ON THIS PAGE WE SHOW USING METAL WALL AND METAL CEILING BOXES. THE WIRING IN PLASTIC AND METAL BOXES IS THE SAME, EXCEPT FOR THE GROUND WIRE. THE GROUND WIRE ATTACHES TO THE METAL BOXES, IN PLASTIC IT DOES NOT, SEE PAGE 6 AND 7 FOR MORE ON HOW THE GROUND WIRE WORKS IN PLASTIC BOXES.

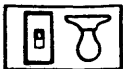

WIRING COLOR GUIDE		
	WHITE WIRE	neutral
	BLACK WIRE	hot
	RED WIRE	hot
	BARE WIRE	ground wire

How to Wire Single Pole Switch

With Switch Controlling One Light

WIRE NUT GUIDE	
	USE RED WIRE NUTS WHERE WIRE NUTS ARE USED ON THIS PAGE INCLUDING GROUND WIRES

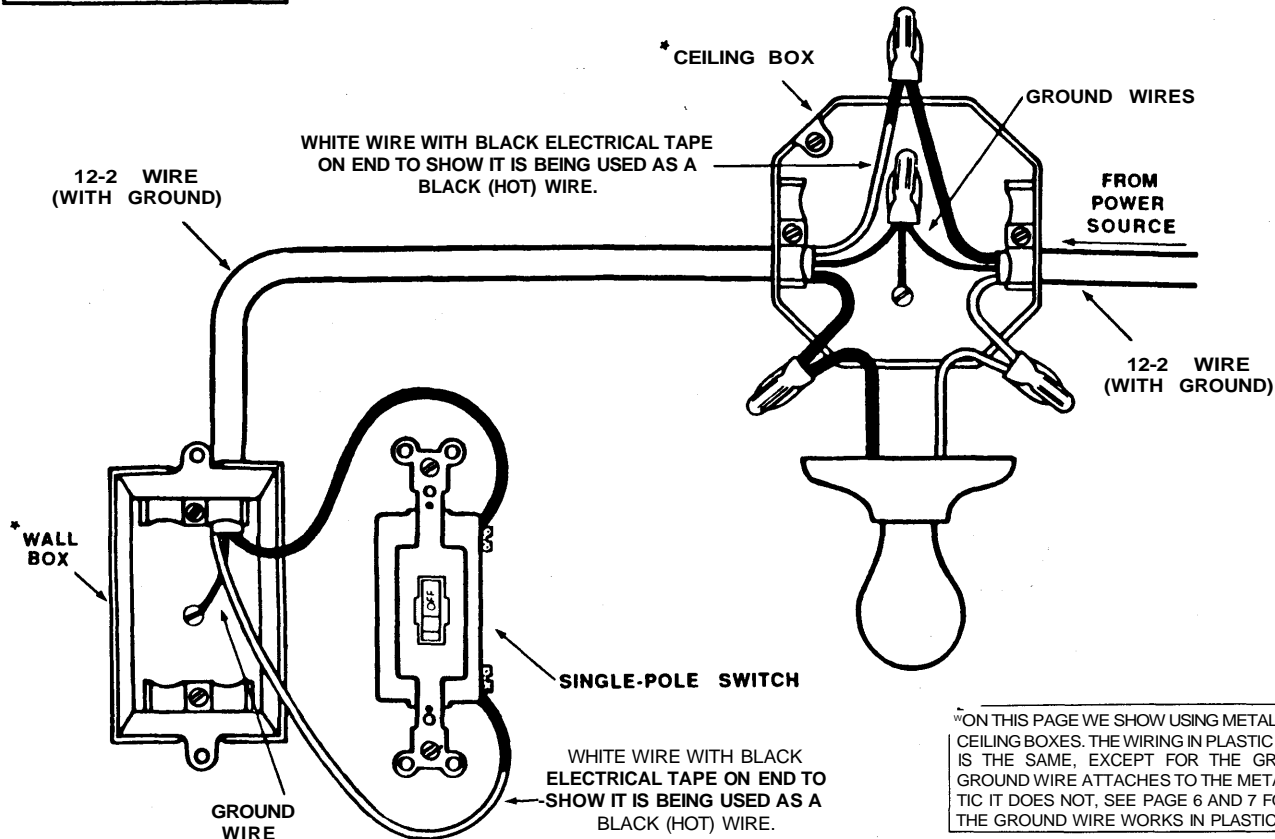

* ON THIS PAGE WE SHOW USING METAL WALL AND METAL CEILING BOXES. THE WIRING IN PLASTIC AND METAL BOXES IS THE SAME, EXCEPT FOR THE GROUND WIRE. THE GROUND WIRE ATTACHES TO THE METAL BOXES, IN PLASTIC IT DOES NOT, SEE PAGE 6 AND 7 FOR MORE ON HOW THE GROUND WIRE WORKS IN PLASTIC BOXES.



WIRING COLOR GUIDE		
	WHITE WIRE	neutral
	BLACK WIRE	hot
	RED WIRE	hot
	BARE WIRE	ground wire

How To Wire Single Pole Switch

With Switch Controlling Two Lights

WIRE NUT GUIDE	
	USE RED WIRE NUTS WHERE WIRE NUTS ARE USED ON THIS PAGE INCLUDING GROUND WIRES

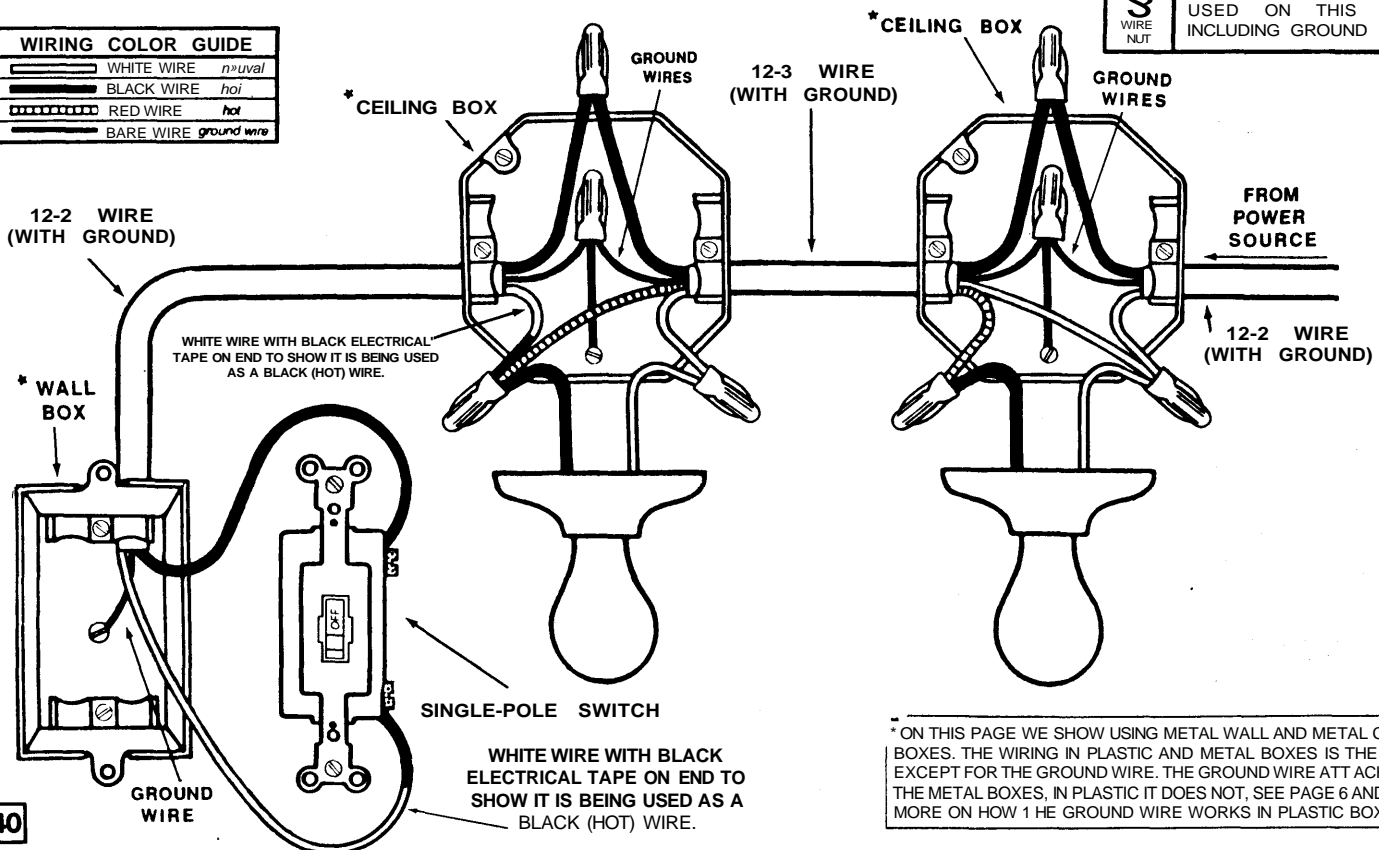

* ON THIS PAGE WE SHOW USING METAL WALL AND METAL CEILING BOXES. THE WIRING IN PLASTIC AND METAL BOXES IS THE SAME, EXCEPT FOR THE GROUND WIRE. THE GROUND WIRE ATTACHES TO THE METAL BOXES, IN PLASTIC IT DOES NOT, SEE PAGE 6 AND 7 FOR MORE ON HOW THE GROUND WIRE WORKS IN PLASTIC BOXES.

WIRING COLOR GUIDE	
	WHITE WIRE, NEUTRAL
	BLACK WIRE, HOT
	RED WIRE, HOT
	BARE WIRE GROUND WIRE

How To Wire Single Pole Switch With Switch Controlling Three Lights

WIRE NUT GUIDE	
	USE RED WIRE NUTS WHERE WIRE NUTS ARE USED ON THIS PAGE INCLUDING GROUND WIRES

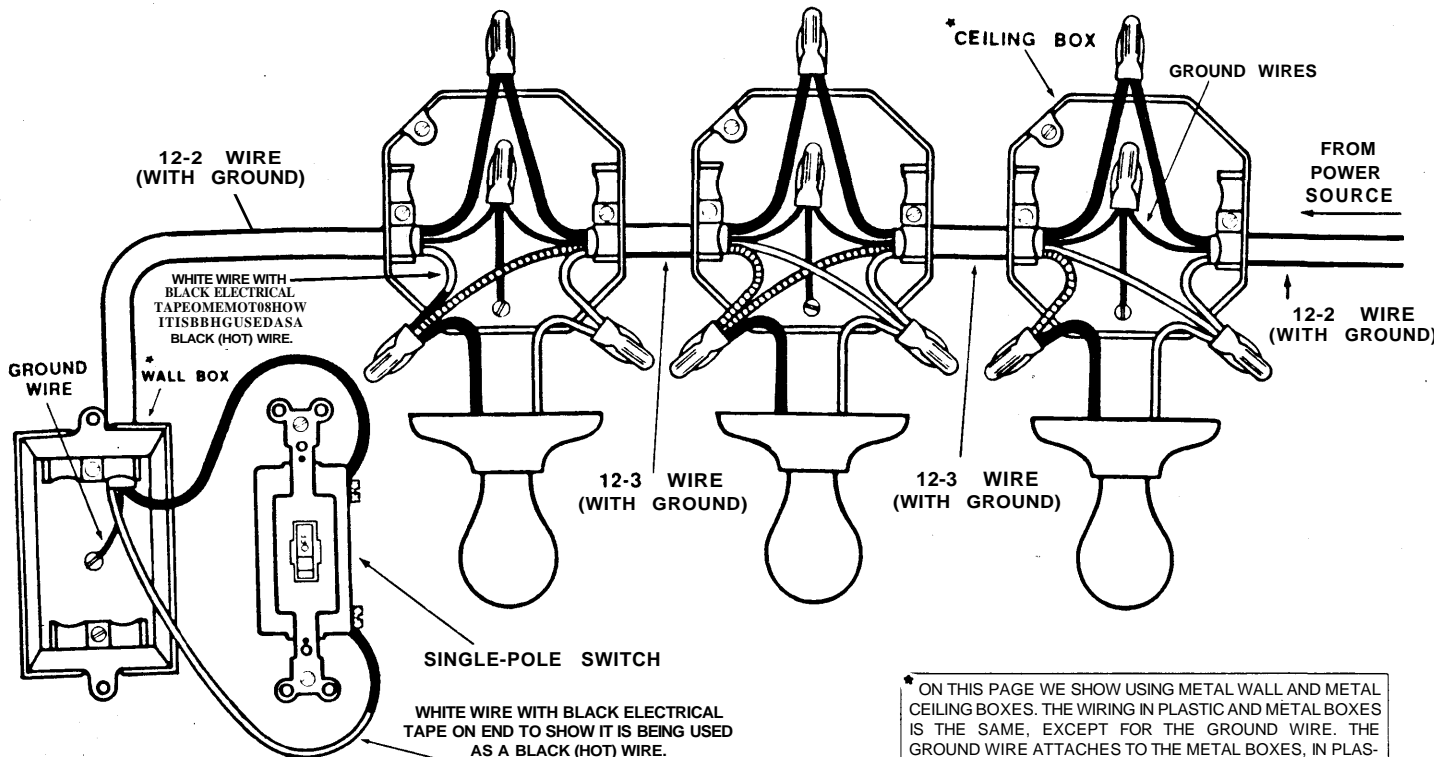

* ON THIS PAGE WE SHOW USING METAL WALL AND METAL CEILING BOXES. THE WIRING IN PLASTIC AND METAL BOXES IS THE SAME, EXCEPT FOR THE GROUND WIRE. THE GROUND WIRE ATTACHES TO THE METAL BOXES, IN PLASTIC IT DOES NOT, SEE PAGE 6 AND 7 FOR MORE ON HOW THE GROUND WIRE WORKS IN PLASTIC BOXES.

WIRING COLOR GUIDE	
	WHITE WIRE, NEUTRAL
	BLACK WIRE, HOT
	RED WIRE, HOT
	BARE WIRE GROUND WIRE

How to Wire Single Pole Switch With Switch Controlling Four Lights

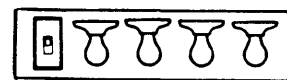

WIRE NUT GUIDE	
	USE RED WIRE NUTS WHERE WIRE NUTS ARE USED ON THIS PAGE INCLUDING GROUND WIRES

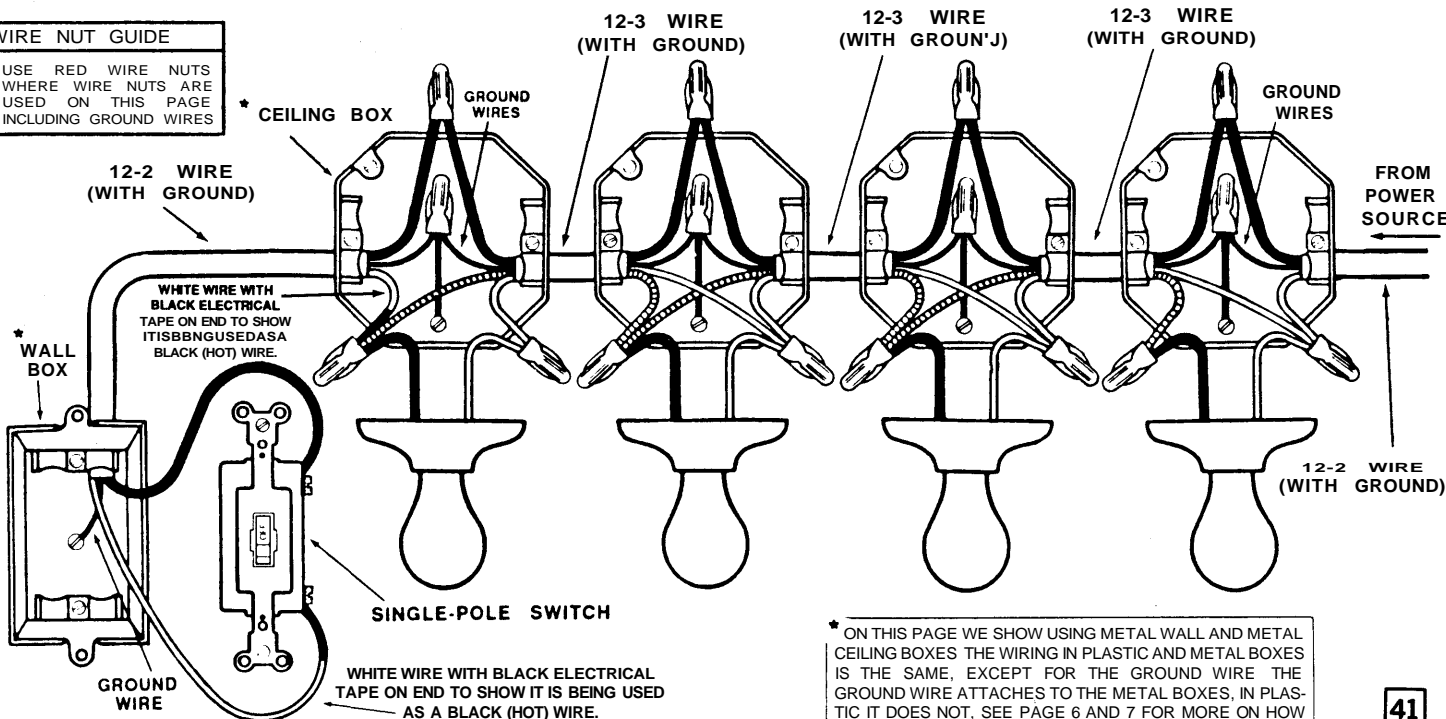

* ON THIS PAGE WE SHOW USING METAL WALL AND METAL CEILING BOXES THE WIRING IN PLASTIC AND METAL BOXES IS THE SAME, EXCEPT FOR THE GROUND WIRE. THE GROUND WIRE ATTACHES TO THE METAL BOXES, IN PLASTIC IT DOES NOT, SEE PAGE 6 AND 7 FOR MORE ON HOW THE GROUND WIRE WORKS IN PLASTIC BOXES.



One Power Source Supplying Two Single Pole Switches With Lights

WIRING COLOR GUIDE	
	WHITE WIRE <i>neutral</i>
	BLACK WIRE <i>hot</i>
	RED WIRE <i>hot</i>
	BARE WIRE <i>ground wire</i>

WIRE NUT GUIDE	
fl. <small>red wire nut</small>	USE RED WIRE NUTS WHERE WIRE NUTS ARE USED ON THIS PAGE INCLUDING GROUNDWIRES

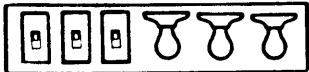
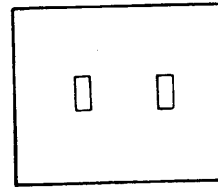
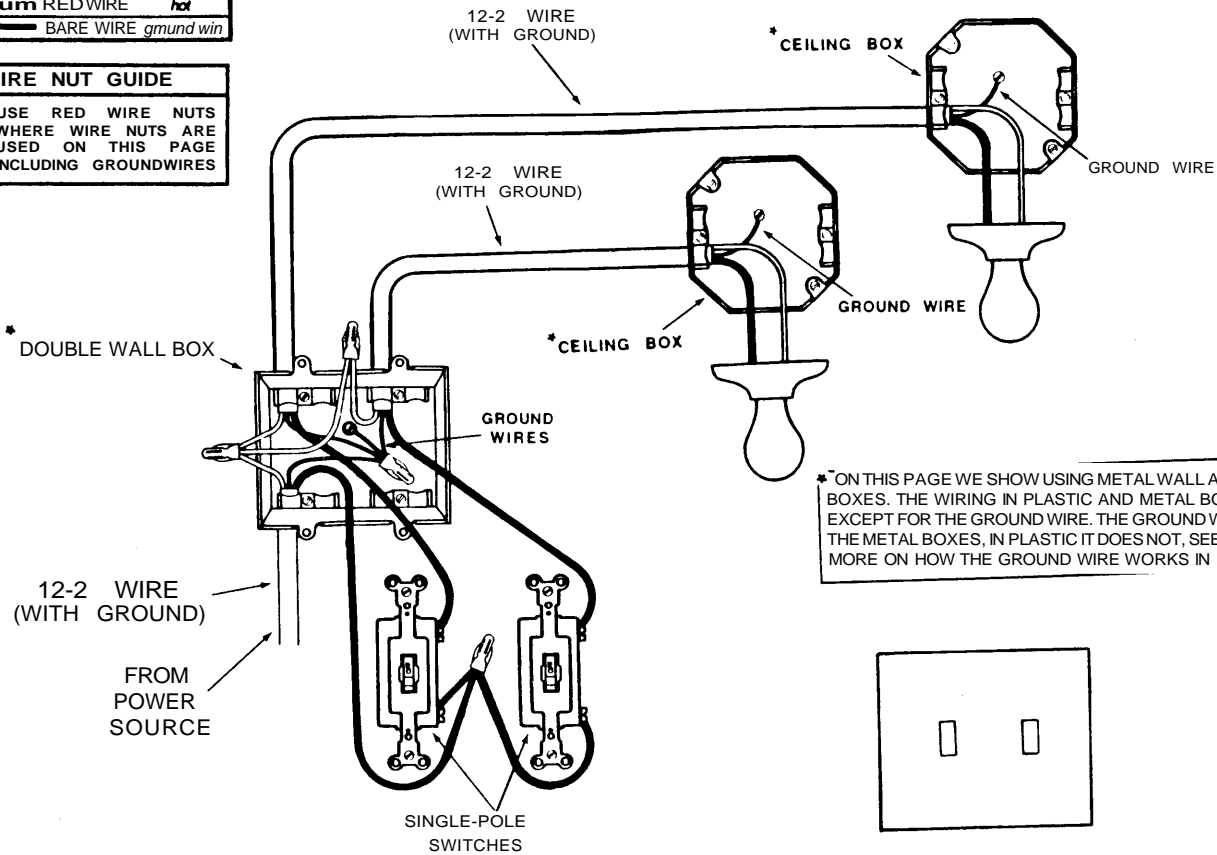

One Power Source Supplying Three Single Pole Switches With Lights

WIRING COLOR GUIDE	
	WHITE WIRE <i>neutral</i>
	BLACK WIRE <i>hot</i>
	RED WIRE <i>hot</i>
	BARE WIRE <i>ground wire</i>

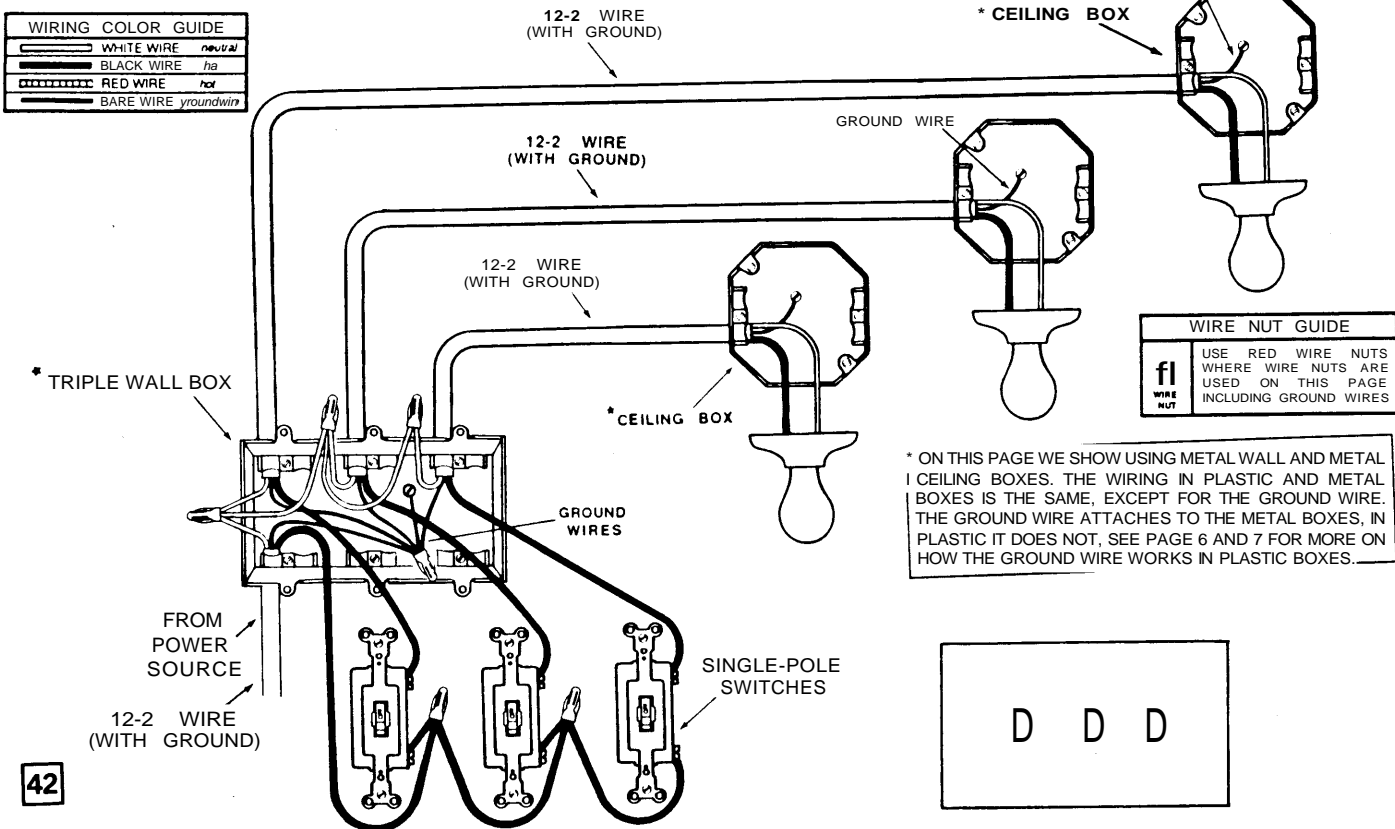

WIRE NUT GUIDE	
fl. <small>red wire nut</small>	USE RED WIRE NUTS WHERE WIRE NUTS ARE USED ON THIS PAGE INCLUDING GROUND WIRES

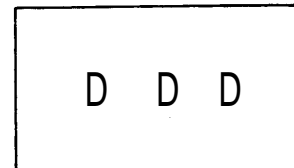

WIRING COLOR GUIDE	
	WHITE WIRE NEUTRAL
	BLACK WIRE HOT
	RED WIRE HOT
	BARE WIRE (GROUND WIRE)

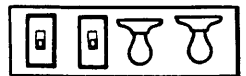

One Power Source Supplying Two Single Pole Switches with Lights

WIRE NUT GUIDE	
	USE RED WIRE NUTS WHERE WIRE NUTS ARE USED ON THIS PAGE INCLUDING GROUND WIRES

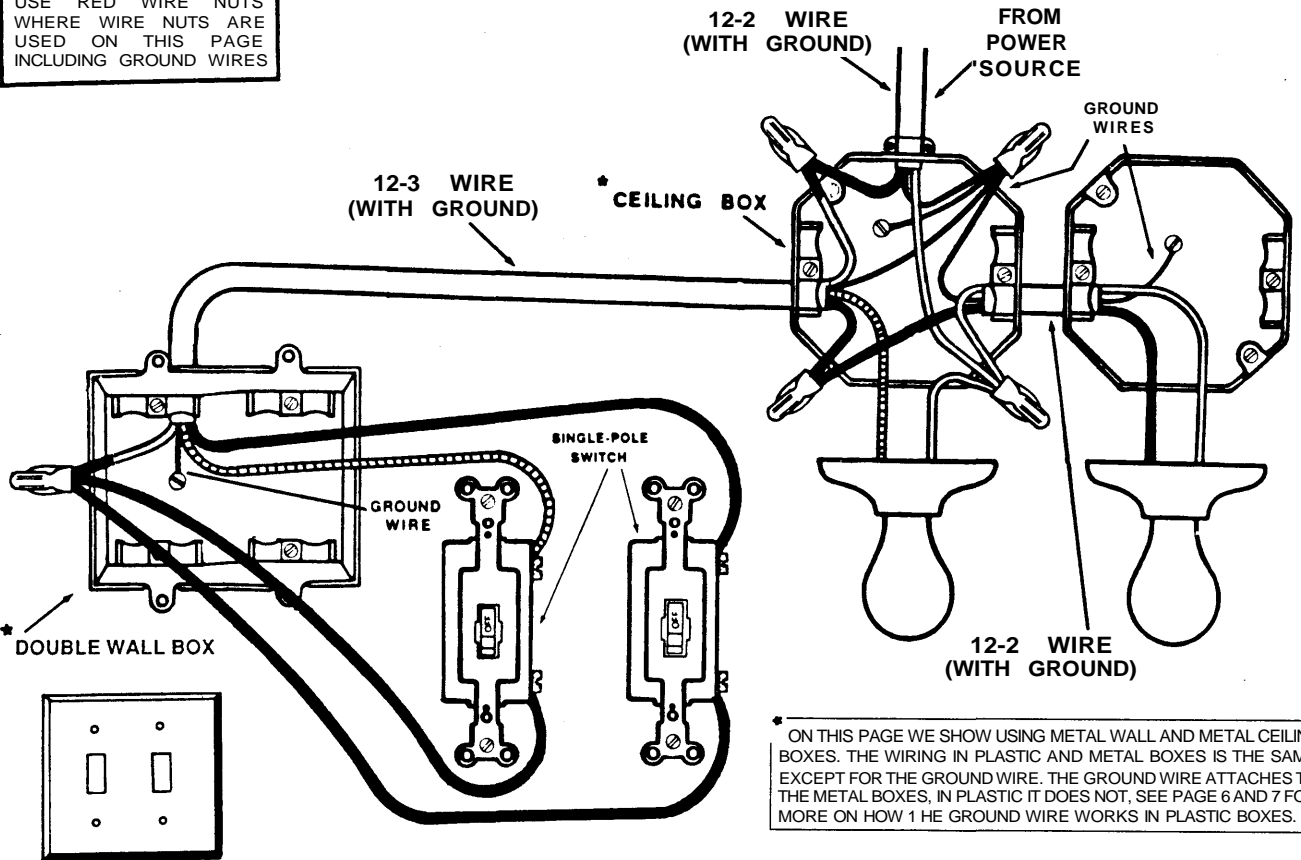

* ON THIS PAGE WE SHOW USING METAL WALL AND METAL CEILING BOXES. THE WIRING IN PLASTIC AND METAL BOXES IS THE SAME, EXCEPT FOR THE GROUND WIRE. THE GROUND WIRE ATTACHES TO THE METAL BOXES, IN PLASTIC IT DOES NOT, SEE PAGE 6 AND 7 FOR MORE ON HOW THE GROUND WIRE WORKS IN PLASTIC BOXES.

WIRING COLOR GUIDE	
	WHITE WIRE NEUTRAL
	BLACK WIRE HOT
	RED WIRE HOT
	BARE WIRE GROUND WIRE

How to Wire a Single Pole Switch With Lights and Outlets



WIRE NUT GUIDE	
	USE RED WIRE NUTS WHERE WIRE NUTS ARE USED ON THIS PAGE INCLUDING GROUND WIRES

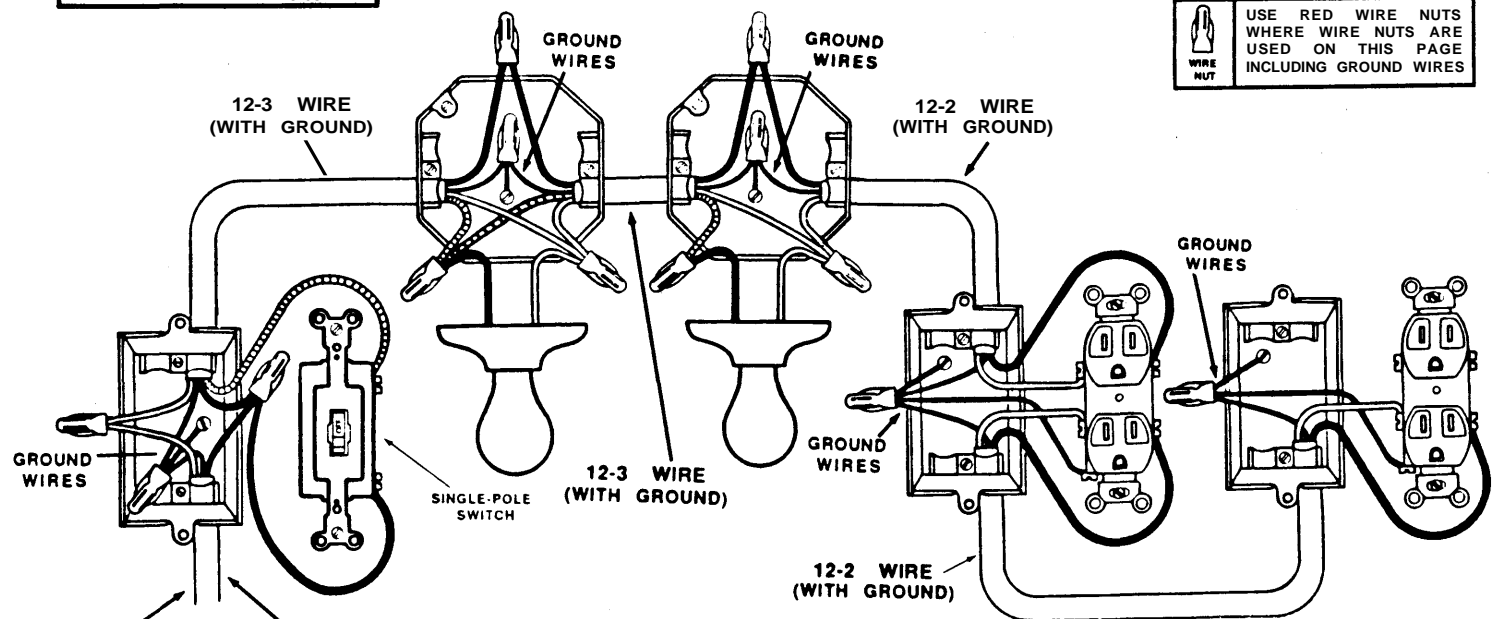

* ON THIS PAGE WE SHOW USING METAL WALL AND METAL CEILING BOXES. THE WIRING IN PLASTIC AND METAL BOXES IS THE SAME, EXCEPT FOR THE GROUND WIRE. THE GROUND WIRE ATTACHES TO THE METAL BOXES, IN PLASTIC IT DOES NOT, SEE PAGE 6 AND 7 FOR MORE ON HOW THE GROUND WIRE WORKS IN PLASTIC BOXES.

All About Four-Way Switches

ON THIS PAGE WE SHOW USING METAL WALL AND METAL CEILING BOXES. THE WIRING IN PLASTIC AND METAL BOXES IS THE SAME, EXCEPT FOR THE GROUND WIRE. THE GROUND WIRE ATTACHES TO THE METAL BOXES, IN PLASTIC IT DOES NOT, SEE PAGE 6 AND 7 FOR MORE ON HOW THE GROUND WIRE WORKS IN PLASTIC BOXES.

WIRING COLOR GUIDE		
	WHITE WIRE	NEUTRAL
	BLACK WIRE	HOT
	RED WIRE	HOT
	BARE WIRE	GROUND WIRE

WIRE NUT GUIDE	
	USE RED WIRE NUTS WHERE WIRE NUTS ARE USED ON THIS PAGE INCLUDING GROUND WIRES

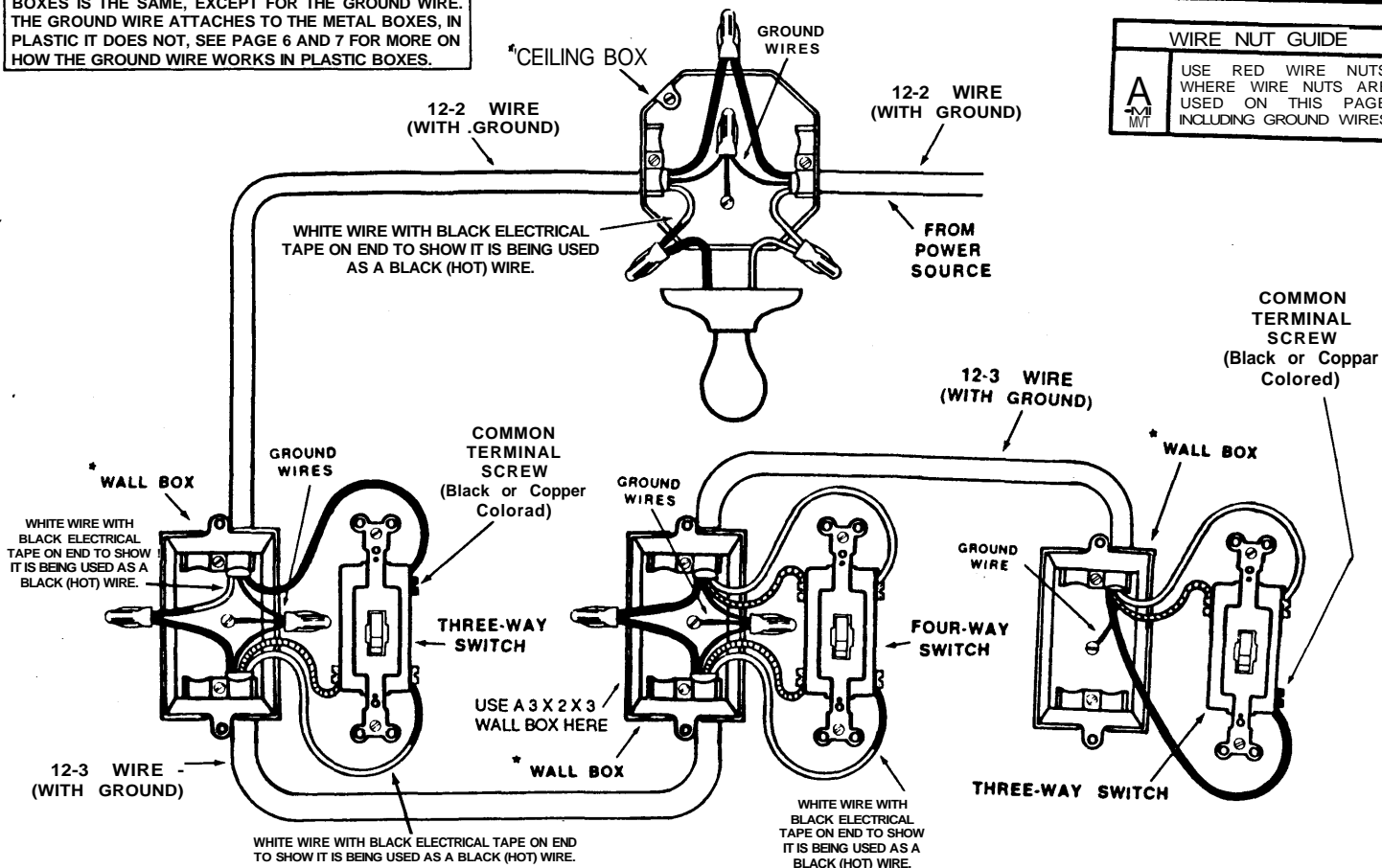

WIRING COLOR GUIDE		
	WHITE WIRE	NEUTRAL
	BLACK WIRE	HOT
	RED WIRE	HOT
	BARE WIRE	GROUND WIRE

How to wire a switch controlled outlet

BLACK WIRE ATTACHED TO BRASS TERMINAL SCREW

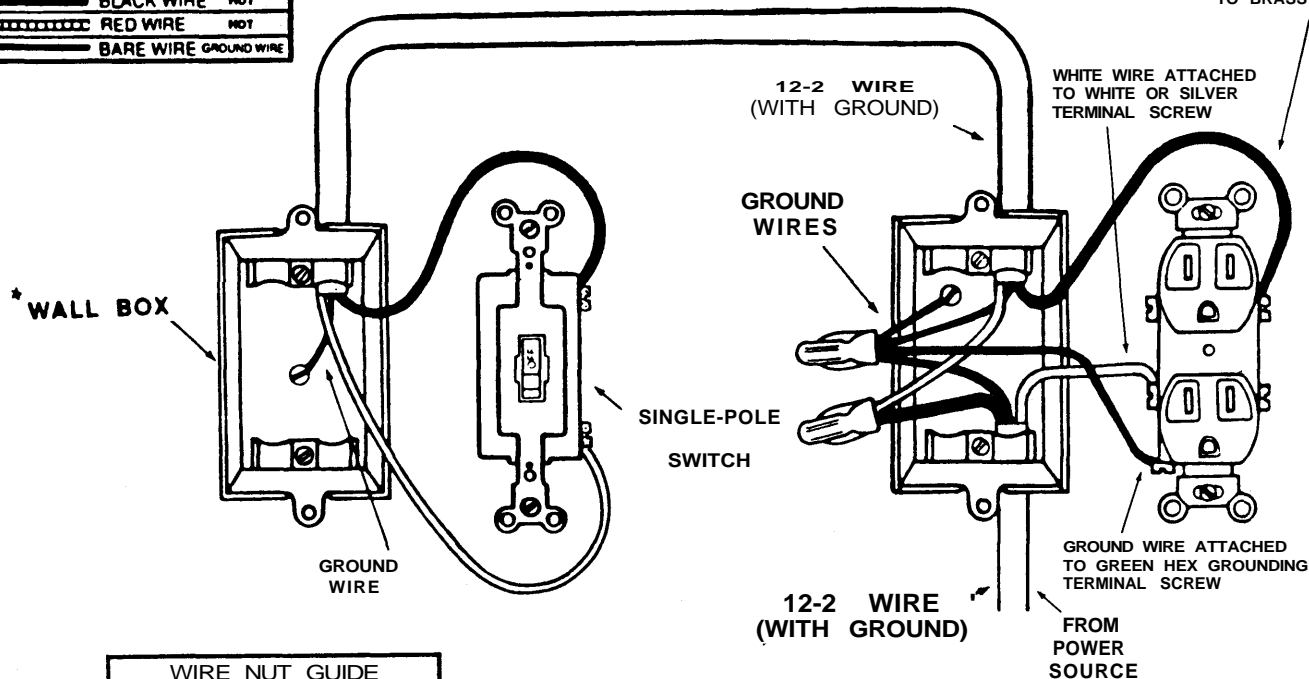

WIRE NUT GUIDE	
	USE RED WIRE NUTS WHERE WIRE NUTS ARE USED ON THIS PAGE INCLUDING GROUNDWIRES

* ON THIS PAGE WE SHOW USING METAL WALL AND METAL CEILING BOXES. THE WIRING IN PLASTIC AND METAL BOXES IS THE SAME, EXCEPT FOR THE GROUND WIRE. THE GROUND WIRE ATTACHES TO THE METAL BOXES, IN PLASTIC IT DOES NOT, SEE PAGE 6 AND 7 FOR MORE ON HOW THE GROUND WIRE WORKS IN PLASTIC BOXES.

How to Wire Outlet and Light with Pull Chain

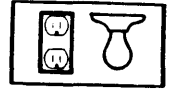

WIRING COLOR GUIDE		
	WHITE WIRE	NEUTRAL
	BLACK WIRE	HOT
	RED WIRE	HOT
	BARE WIRE	GROUND WIRE

WIRE NUT GUIDE
 USE RED WIRE NUTS WHERE WIRE NUTS ARE USED ON THIS PAGE INCLUDING GROUND WIRES

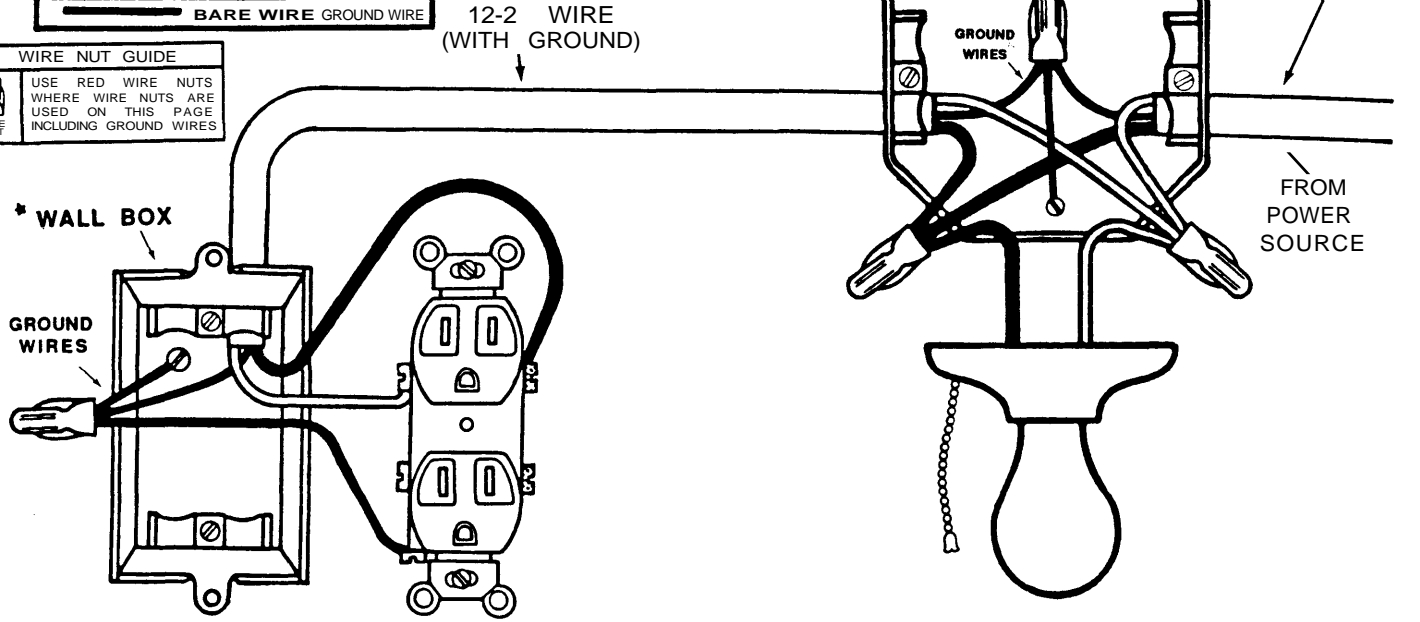

* ON THIS PAGE WE SHOW USING METAL WALL AND METAL CEILING BOXES. THE WIRING IN PLASTIC AND METAL BOXES IS THE SAME, EXCEPT FOR THE GROUND WIRE. THE GROUND WIRE ATTACHES TO THE METAL BOXES, IN PLASTIC IT DOES NOT, SEE PAGE 6 AND 7 FOR MORE ON HOW THE GROUND WIRE WORKS IN PLASTIC BOXES.

How To Wire Outlet and Light With Pull Chain

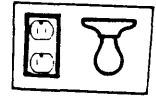

WIRING COLOR GUIDE		
	3 WHITE WIRE	NEUTRAL
	BLACK WIRE	HOT
	RED WIRE	HOT
	BARE WIRE	GROUND WIRE

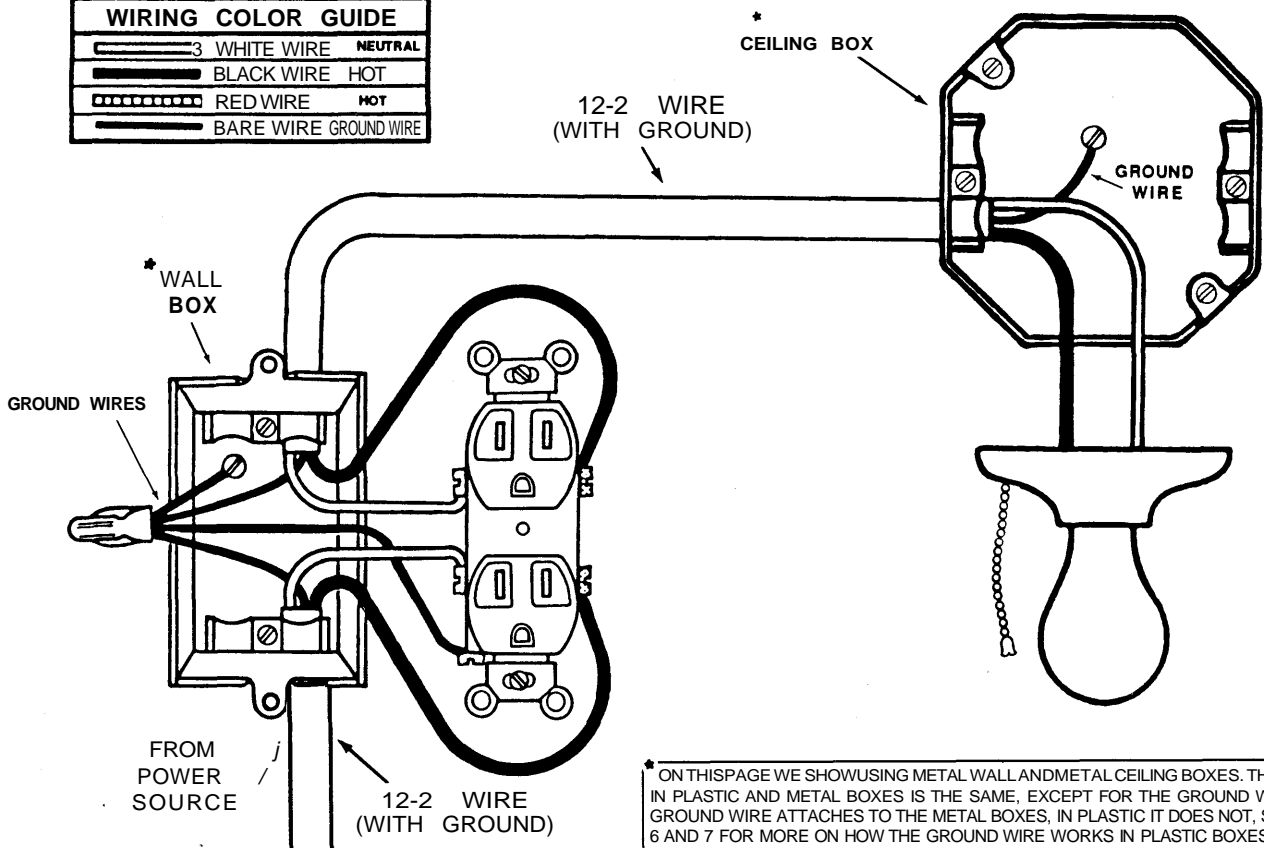

* ON THIS PAGE WE SHOW USING METAL WALL AND METAL CEILING BOXES. THE WIRING IN PLASTIC AND METAL BOXES IS THE SAME, EXCEPT FOR THE GROUND WIRE. THE GROUND WIRE ATTACHES TO THE METAL BOXES, IN PLASTIC IT DOES NOT, SEE PAGE 6 AND 7 FOR MORE ON HOW THE GROUND WIRE WORKS IN PLASTIC BOXES.

WIRING COLOR GUIDE	
	WHITE WIRE <i>neutral</i>
	BLACK WIRE <i>hot</i>
	RED WIRE <i>hot</i>
	BARE WIRE <i>ground wire</i>

WIRE NUT GUIDE	
	USE RED WIRE NUTS WHERE WIRE NUTS ARE USED ON THIS PAGE INCLUDING GROUND WIRES

How To Wire Outlet-Switch and Light

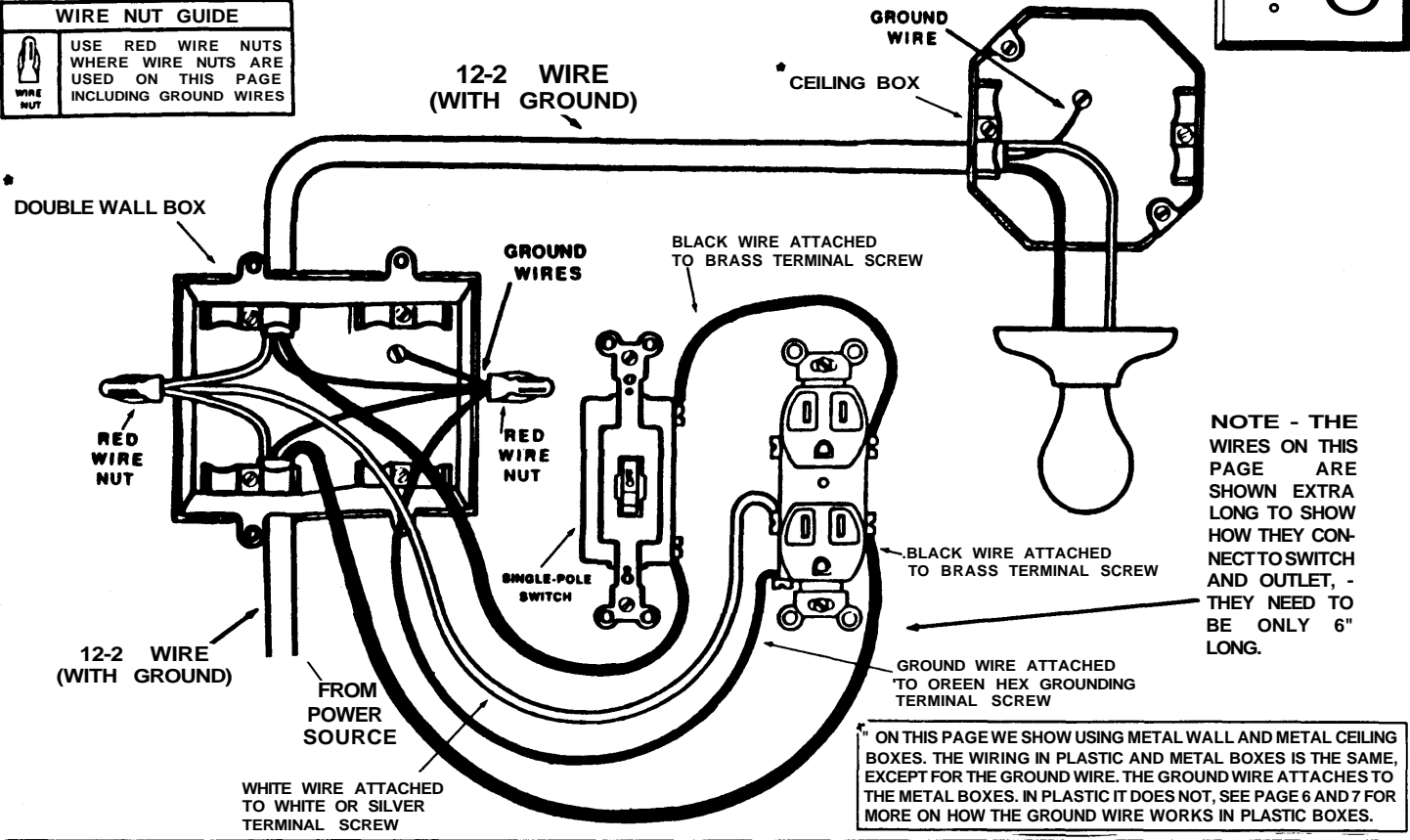
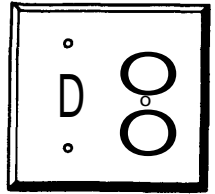

NOTE - THE WIRES ON THIS PAGE ARE SHOWN EXTRA LONG TO SHOW HOW THEY CONNECT TO SWITCH AND OUTLET, - THEY NEED TO BE ONLY 6" LONG.

* ON THIS PAGE WE SHOW USING METAL WALL AND METAL CEILING BOXES. THE WIRING IN PLASTIC AND METAL BOXES IS THE SAME, EXCEPT FOR THE GROUND WIRE. THE GROUND WIRE ATTACHES TO THE METAL BOXES. IN PLASTIC IT DOES NOT, SEE PAGE 6 AND 7 FOR MORE ON HOW THE GROUND WIRE WORKS IN PLASTIC BOXES.



How To Wire Outlet-Switch and Light

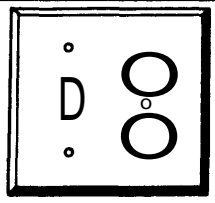

WIRING COLOR GUIDE	
	WHITE WIRE *****
	BLACK WIRE HOT
	RED WIRE NOT
	BARE WIRE GROUND WIRE

WIRE NUT GUIDE	
	USE RED WIRE NUTS WHERE WIRE NUTS ARE USED ON THIS PAGE INCLUDING GROUND WIRES

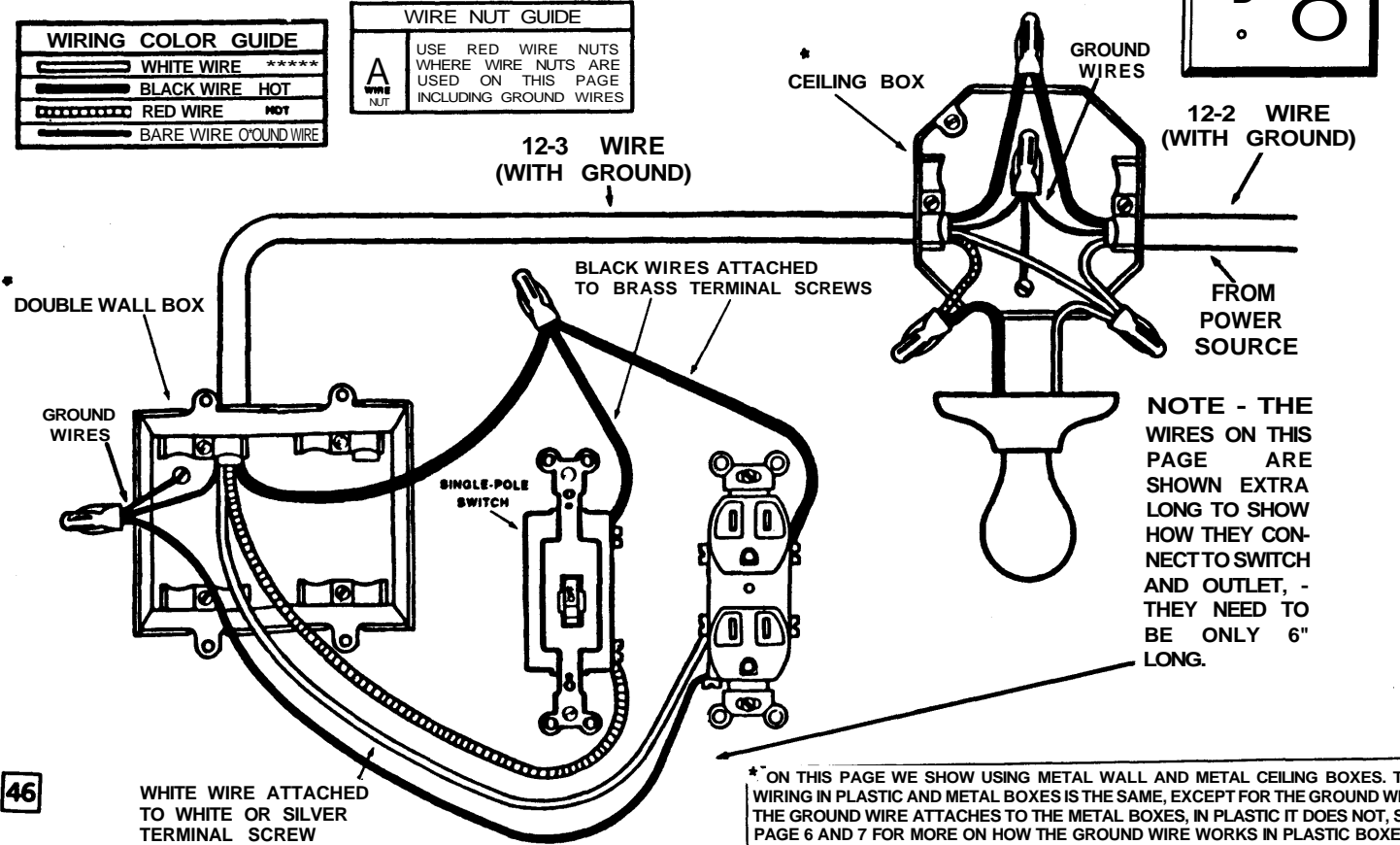





NOTE - THE WIRES ON THIS PAGE ARE SHOWN EXTRA LONG TO SHOW HOW THEY CONNECT TO SWITCH AND OUTLET, - THEY NEED TO BE ONLY 6" LONG.

* ON THIS PAGE WE SHOW USING METAL WALL AND METAL CEILING BOXES. THE WIRING IN PLASTIC AND METAL BOXES IS THE SAME, EXCEPT FOR THE GROUND WIRE. THE GROUND WIRE ATTACHES TO THE METAL BOXES, IN PLASTIC IT DOES NOT, SEE PAGE 6 AND 7 FOR MORE ON HOW THE GROUND WIRE WORKS IN PLASTIC BOXES.



How to Wire a Single Pole Switch, Light, and Outlet

WIRE NUT GUIDE	
	USE RED WIRE NUTS WHERE WIRE NUTS ARE USED ON THIS PAGE INCLUDING GROUNDWIRES

WIRING COLOR GUIDE	
	WHITE WIRE neutral
	BLACK WIRE hot
	RED WIRE hot
	BARE WIRE ground wire

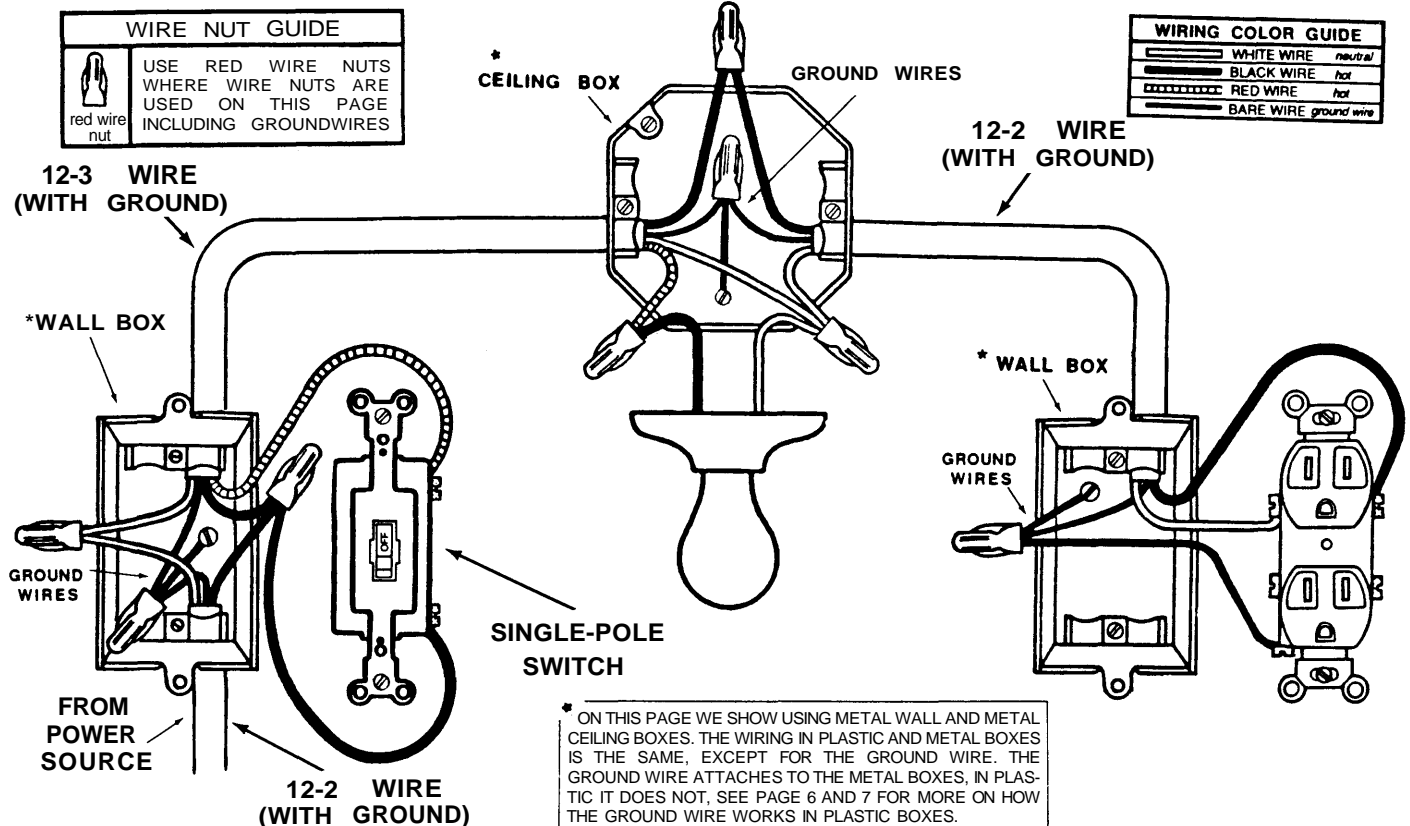





* ON THIS PAGE WE SHOW USING METAL WALL AND METAL CEILING BOXES. THE WIRING IN PLASTIC AND METAL BOXES IS THE SAME, EXCEPT FOR THE GROUND WIRE. THE GROUND WIRE ATTACHES TO THE METAL BOXES, IN PLASTIC IT DOES NOT, SEE PAGE 6 AND 7 FOR MORE ON HOW THE GROUND WIRE WORKS IN PLASTIC BOXES.

How To Wire Outlet-Switch and Light



WIRE NUT GUIDE	
	USE RED WIRE NUTS ON ALL WIRING DIAGRAMS ON THIS PAGE INCLUDING GROUND WIRES

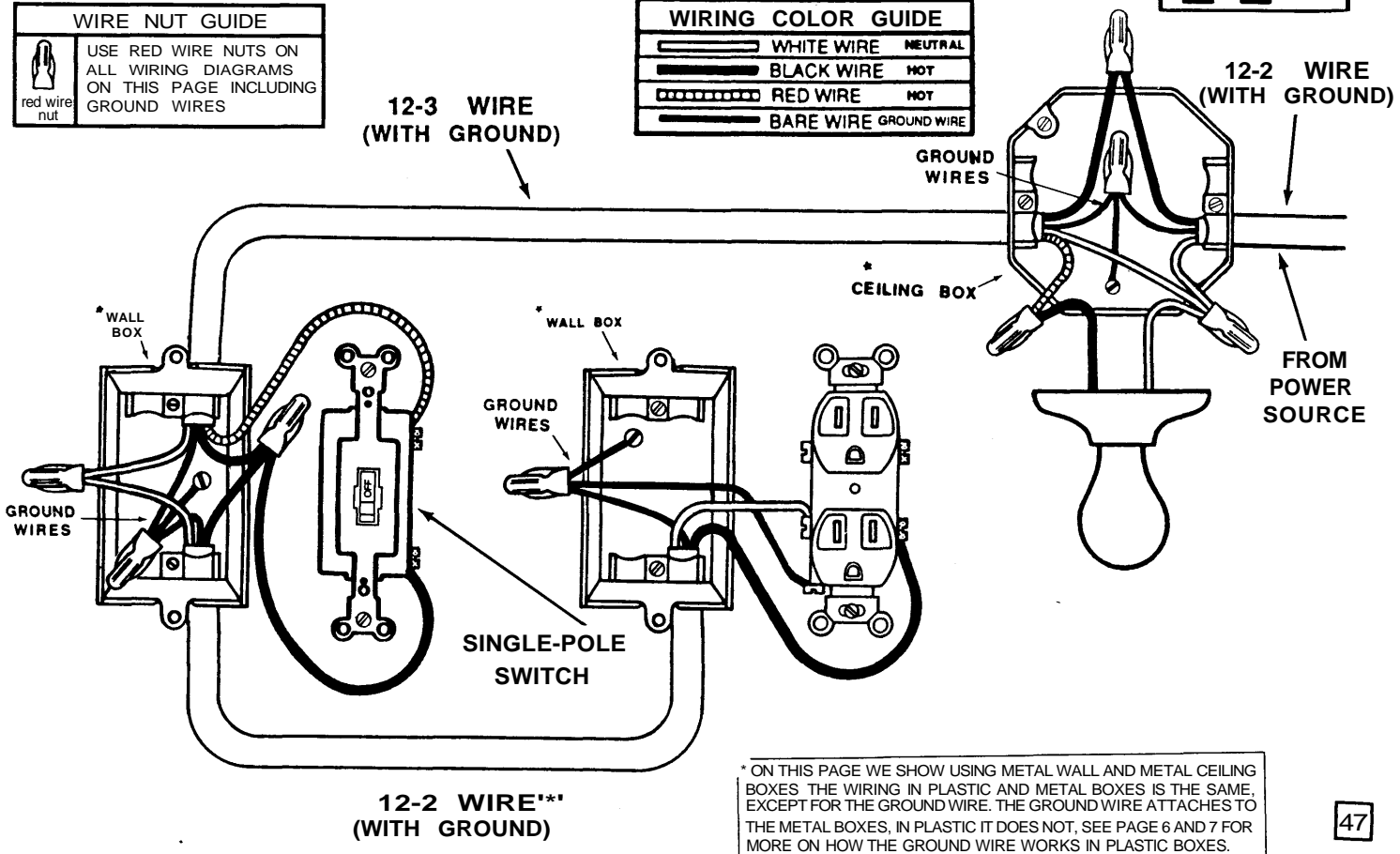

WIRING COLOR GUIDE	
	WHITE WIRE NEUTRAL
	BLACK WIRE HOT
	RED WIRE HOT
	BARE WIRE GROUND WIRE



* ON THIS PAGE WE SHOW USING METAL WALL AND METAL CEILING BOXES. THE WIRING IN PLASTIC AND METAL BOXES IS THE SAME, EXCEPT FOR THE GROUND WIRE. THE GROUND WIRE ATTACHES TO THE METAL BOXES, IN PLASTIC IT DOES NOT, SEE PAGE 6 AND 7 FOR MORE ON HOW THE GROUND WIRE WORKS IN PLASTIC BOXES.

OTHER FINE BOOKS FROM
STEP BY STEP GUIDE BOOK CO.

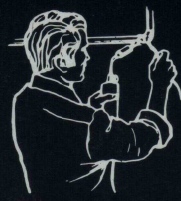
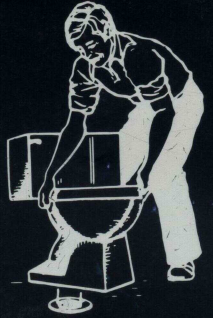
STEP BY STEP
GUIDE BOOK ON
HOME PLUMBING NO. 2



OVER 300
HOW-TO-DO-IT
PICTURES

OUR HOME PLUMBING BOOK
IS 8 1/2" X 11" AND CONTAINS
56 PAGES.

STEP BY STEP
GUIDE BOOK ON
SPRINKLING SYSTEMS NO. 4

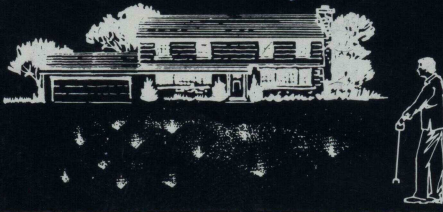
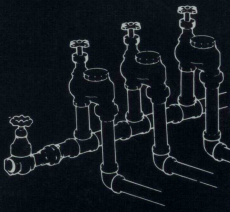

OVER 300
HOW-TO-DO-IT
PICTURES

SIMPLIFIED, COMPLETE INSTALLATION MANUAL

OUR SPRINKLER BOOK
IS 8 1/2" X 11" AND CONTAINS
38 PAGES.



ISBN -O-9619201-0-6