

Rudolf F. Graf • William Sheets

Build Your Own Low-Power Transmitters

Projects for the Electronics Experimenter

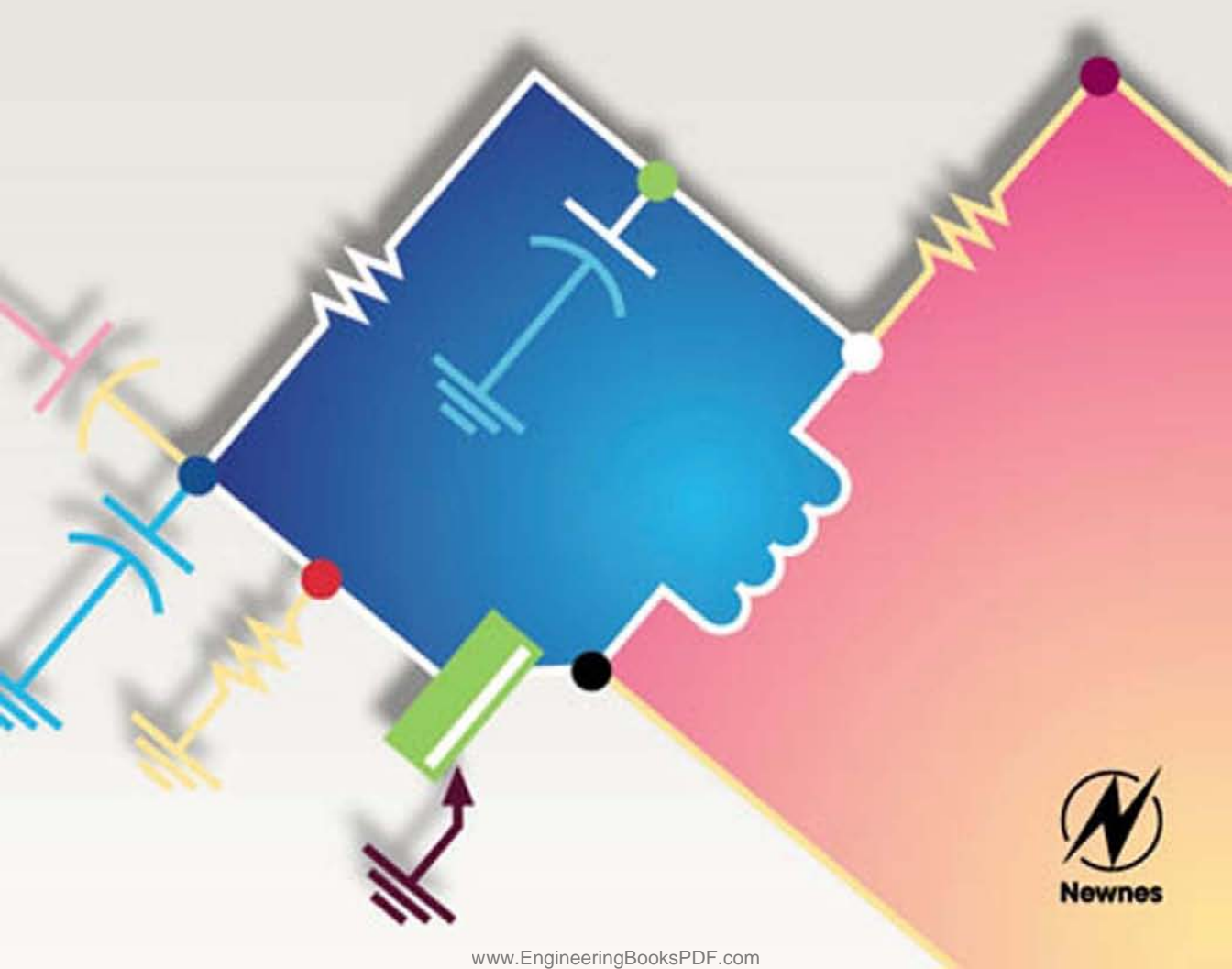

Build Your Own Low-Power Transmitters

Projects for the Electronics Experimenter

This Page Intentionally Left Blank

Build Your Own Low-Power Transmitters

Projects for the Electronics Experimenter

Rudolf F. Graf

William Sheets



Boston Oxford Auckland Johannesburg Melbourne New Delhi

Newnes is an imprint of Butterworth–Heinemann.

Copyright © 2001 Rudolf F. Graf and William Sheets

 A member of the Reed Elsevier group

All rights reserved.

No part of this publication may be reproduced, stored in a retrieval system, or transmitted in any form or by any means, electronic, mechanical, photocopying, recording, or otherwise, without the prior written permission of the publisher.

-  Recognizing the importance of preserving what has been written, Butterworth–Heinemann prints its books on acid-free paper whenever possible.



Butterworth–Heinemann supports the efforts of American Forests and the Global ReLeaf program in its campaign for the betterment of trees, forests, and our environment.

Library of Congress Cataloging-in-Publication Data

Graf, Rudolf F.

Build your own low-power transmitters : projects for the electronics experimenter / Rudolf F. Graf, William Sheets.

p. cm.

ISBN 0-7506-7244-7 (alk. Paper)

1. Radio—Transmitters and transmission—Design and construction—Amateurs' manuals. 2. Low voltage systems—Designs and construction—Amateurs' manuals. I. Sheets, William. II. Title.

TK6561 .G67 2001

621 .384'131—dc21

2001030550

British Library Cataloguing-in-Publication Data

A catalogue record for this book is available from the British Library.

The publisher offers special discounts on bulk orders of this book.

For information, please contact:

Manager of Special Sales

Butterworth–Heinemann

225 Wildwood Avenue

Woburn, MA 01801-2041

Tel: 781-904-2500

Fax: 781-904-2620

For information on all Newnes publications available, contact our World Wide Web home page at: <http://www.newnespress.com>.

10 9 8 7 6 5 4 3 2 1

Printed in the United States of America

*In appreciation of their patience and understanding
during the preparation of the manuscript,
we are pleased to dedicate this book to our wives
Bettina and Cindy.*

This Page Intentionally Left Blank

Contents

Preface xi

- 1. Low-Power Transmitters, General 1**
 - Basic Oscillator 2
 - Master Oscillator–Power Amplifier 4
 - Heterodyne Mixer–Power Amplifier 4
- 2. Basic Building Blocks 9**
 - Oscillators 9
 - Amplifiers 13
 - Multipliers 14
 - Modulators 16
 - Frequency Synthesizer (PLL) Circuits 19
- 3. Simple Low-Power Transmitters for Experimenters 23**
 - Wireless Microphone 23
 - Baby Monitor 25
 - Room “Bug” 26
 - Telephone Line “Bug” 27
 - AM Transmitter 28
- 4. 50 mW VFO-Controlled AM Transmitter for 530-1710 kHz 31**
 - Parts List 34
- 5. PLL Synthesized AM Transmitter for 530-1710 kHz 35**
 - Parts List 49
 - DIP Switch Settings 50
 - Filter Settings 50
 - Programming 51
 - DIP Switch S1 Frequency Settings 51*
 - Calculation of the Binary Code for Frequency 52*
- 6. VFO Controlled FM Monaural Transmitter for 88-108 MHz 55**
- 7. Basic FM Stereo Signal Generation Techniques 61**

- 8. PLL Synthesized FM Stereo Transmitter for 88-108 MHz 69**
 - Circuit Operation 71
 - Construction Procedure 78
 - Test and Setup Procedure 81
 - Packaging Considerations 84
 - Frequency Programming 85
 - Applications 86
 - Operation Outside the United States 88
 - Frequency Programming Chart 88
 - Parts List 91

- 9. Microprocessor-Controlled FM Stereo Transmitter for 88-108 MHz 93**
 - MPX2000 Theory of Operation 93
 - MPX2000 Circuitry 93
 - Construction of the MPX2000 101
 - PC Board Assembly 101*
 - Audio and MPX Generator Checkout 105*
 - Voltage Settings and Display Assembly 106*
 - Microcontroller and Logic 107*
 - PLL and RF Section 107*
 - Final Test and Setup 109*
 - Packaging 110*
 - Antennas 112*
 - Parts List 112

- 10. 20 mW Low-Power TV Transmitter 117**

- 11. 0.5-Watt TV Transmitter for R/C Vehicles 121**
 - Parts List 129

- 12. 2-Watt TV Transmitter for R/C and Amateur TV for 440 MHz 131**
 - General Description 131
 - Circuit Operation 132
 - Construction Procedures 136
 - Tuneup Procedure 139
 - Parts List 144

- 13. 1-Watt TV Transmitters for 902-928 MHz and 1240-1300 MHz 147**
 - General Description 147
 - Circuit Operation 148
 - Construction Procedures 152
 - Tuneup Procedure 155
 - Parts List 160

- 14. Experimental 20 mW 915 MHz PLL FM TV Transmitter 163**

15. Receiving Converters and IF Systems for Low-Power ATV Transmitters	171
Video IF Systems for Use with Downconverters	185
Theory of Operation	188
<i>IF44 and IF66</i>	188
<i>IF70 FM TV</i>	194
Tuneup	206
<i>IF44 and IF66</i>	206
<i>IF70 FM TV</i>	211
Interfacing Considerations	212
16. Low-Power Narrowband FM Audio Transmitters	215
17. Serial Data Transmit-Receive System for Remote Control	223
18. RF Field-Strength Meter for 500 kHz to 3 GHz Transmitter	233
Circuit Operation	236
Test Procedure	240
Packaging	241
Parts List	245
19. Low-Power CW Transmitter for 40 Meters	247
20. Single Sideband Basics	253
21. Basic Single Sideband Generator/Exciter Unit	261
22. 1-Watt CW Transmitter for the 1750-Meter "LOWFER" Band	267
23. Simple CW Identifier	273
Circuit Operation	274
Parts List	279
Appendix	281
Part 15 AM Broadcast Applications	281
Part 15 160–190 KHZ (1750 Meters)	282
FM Dipole for 88–108 MHZ	284
Antennas and Induced Hum in Low-Power Transmitters	286
Antenna Considerations and Range Expectations	286

This Page Intentionally Left Blank

Preface

Build Your Own Low-Power Transmitters was written to fill the need for detailed, project-oriented information pertaining to the design and construction of low-power transmitters. Writing this text involved careful incorporation of details and instruction for the successful completion and operation of 20 low-power audio and video transmitter projects. Hobbyists, technicians, amateur radio operators, and general radio enthusiasts of all skill levels will find this book beneficial; however, the content is designed primarily with the needs of intermediate to advanced radio electronics technicians and experimenters in mind. For successful completion of the projects, some experience is assumed on the part of the experimenter. Project areas covered include RF circuitry and digital techniques. PC board construction is largely used with some surface mount construction where necessary. A few of the projects also use microcontrollers.

This book contains construction details for audio and video transmitters operating at frequencies from 150 kHz to 1300 MHz for Part 15 operation and for Novice Class Amateur use. Included are several low-power AM and FM audio transmitters, from simple, discrete designs to sophisticated PLL-synthesized types. This book also offers chapters on a frequency-synthesized AM broadcast transmitter for 150-1710 kHz, two FM transmitter designs for 88-108 MHz stereo operation, using PLL synthesis digital readouts and microprocessor control, several low-power (0.5-2 watt) TV transmitters covering the 440, 900, and 1300 MHz amateur bands, a data transmitter and receiver, and a chapter on video reception techniques for the special frequencies used.

Other coverage includes a simple low-power CW transmitter, identifier circuits, antennas, and range information. Many projects are of the kind not often seen as published articles. They incorporate modern circuitry techniques, such as PLL synthesis and the use of microprocessors. All projects use standard parts and have been thoroughly tested, with PC board layouts given for most of the projects, as well as parts lists, coil data, and complete setup information. Components and suitable enclosures for several projects are available as kits from the source given in the book. These kits include all necessary parts and drilled and etched PC boards. This convenience simplifies parts procurement and ensures proper performance of each project. We also discuss the legal limits and ramifications of the equipment and offer suggestions and tips for getting the best results from the projects.

A lot of effort has gone into making this book an effective, project-oriented tool for hands-on learning about successfully building low-power transmitters. We hope you will enjoy reading the fruit of our labors and working on the projects contained within.

Rudolf F. Graf and William Sheets
January 2001

This Page Intentionally Left Blank

1. Low-Power Transmitters, General

The subject of low-power transmitters has always been a fascinating one for experimenters. They enable you to operate your own radio station, broadcast music, control devices remotely without wires, do surveillance work, eavesdrop on private conversations, and other things such as remote sensing. Current Federal Communications Commission (FCC) regulations allow the operation of very low-power unlicensed transmitters subject to various restrictions. These restrictions generally regulate operating range and frequency of operation, as well as possibly types of emission and duration of transmissions. The effort entailed in the construction of these devices will be well rewarded, and the knowledge and experience gained can lead to other pursuits such as ham radio, broadcasting careers, and electronic engineering.

Currently, it appears that the low-power FM broadcast transmitter is a popular project. These devices broadcast in the 88–108 MHz band and can have a range of several hundred feet when a sensitive receiver is employed. FCC regulations limit range and field strength at a certain distance. No explicit restrictions are imposed on power, but a single transistor operating at 5 volts or less will easily generate a signal sufficient to accomplish all that is legally allowed for range and field strength. Modern low-power transmitters of this nature are a far cry from the one transistor approach that used to be popular years ago. This approach used an oscillator that is directly modulated with a microphone. FM is obtained by modulating the operating voltages of the oscillator, which in turn affects frequency via a change in transistor parameters. Although this hit-and-miss approach can be made to work, the modern low-power transmitters may employ varactor modulators, microprocessor-controlled frequency synthesis using a phase locked loop (PLL), audio preemphasis, audio mixing and control facilities, and stereo modulator circuitry that generates a “real” baseband multiplex signal. Integrated circuit (IC) devices make these tasks easily implemented with reasonable amounts of circuitry. The audio quality and the frequency stability of transmissions are usually good enough so that it can be difficult to tell the signal from one of these low-power units from that of a commercially licensed station.

AM transmitters that have similar performance characteristics are also available. Currently, AM low-power transmitters operating in the standard AM broadcast band (530–1710 kHz) are allowed 100 milliwatts (mW) into a 10-foot antenna. This allows usable ranges of several hundred feet, with a few miles not impossible with a well-designed antenna system. These transmitters are a far cry from the “phono oscillators” of the 1950s. Radio amateurs using 10–20 watts in the 1.8-MHz (160-meter) ham band have gotten ranges of 50 miles or more using 8-foot whip antennas mounted on automobile bodies, so 100 mW should give a range of 5 miles under identical conditions. The inevitable presence of co-channel interference and noise, however, as well as the desire for a good-sounding, clear signal, generally limits this range to less than 1 mile under the best of circumstances.

Build Your Own Low-Power Transmitters: Projects for the Electronics Experimenter

Several approaches can be taken to the exact system used for low-power transmitter architecture, but these range from simple oscillators to sophisticated synthesized units. The following factors should be considered:

1. *Cost*: Many low-power transmitters are designed for hobby use or for experimentation. They might be considered as expendable in some cases, as for wild-life tracking, surveillance, or remote sensing applications, where they will eventually be lost or destroyed. The low-power transmitter may be sold in kit form, to be assembled by a hobbyist, or as a completed assembly.
2. *Physical size*: This may be an important factor, as in hidden surveillance or as a payload in a model rocket or aircraft, or even attached to an animal collar. Obviously, such transmitters and their accessory components (e.g., battery, microphone or other sensor, and antenna) have to be kept small, requiring surface-mount construction techniques. Other applications may have few size restrictions.
3. *Power considerations*: Available power might be limited, such as a watch or hearing aid battery, or continuously available but limited, such as from a telephone line, or unlimited for all practical purposes, as from a 120- or 240-volt AC power line. The low-power transmitter will have to derive all of its operating voltages from a specific source.
4. *Type of emission* (FM, AM, video, pulse, etc.): The transmitter design is determined by these factors. Simple audio modulation or tone signals are relatively easy, but video and other complex waveforms may require more complicated circuitry with a higher component count.
5. *Quality of transmission desired*: Attributes such as audio or video quality, RF output power, frequency stability, and range dictate the need for certain circuit features. It may be possible or necessary to omit certain circuit elements and features to obtain a certain goal, such as size, cost, or power consumption. Certain factors, such as range of transmission or frequency stability, may mandate other requirements. Often, compromises must be made.
6. *Legal aspects*: FCC Part 15 rules dictate certain power, emission type, range, antenna, RF field strength, and frequency restrictions; however, in government, police, or military work, these restrictions may not apply or are often ignored. For export and in countries other than the United States, different rules may apply. Specific exceptions for power, frequency, and emissions are available to authorized agencies on individual cases, but the experimenter must comply with FCC Part 15 regulations or Part 97 regulations for the amateur radio service, as applicable.

An almost unlimited number of approaches can be taken to low-power transmitter design, but the basic architectures may be classified as follows:

- Basic oscillator
- Master oscillator–power amplifier
- Heterodyne mixer–power amplifier

Basic Oscillator

The basic oscillator is simply what it says (see Figure 1-1). An oscillator circuit generates the RF carrier and outputs it to a load, generally the antenna. A modulator circuit

Figure 1-1
Basic Transmitter
Architecture

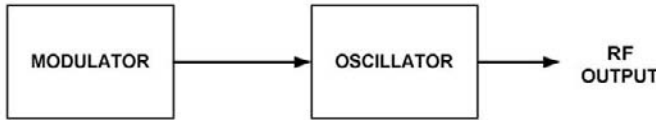

BASIC OSCILLATOR WITH FM MODULATOR



MASTER OSCILLATOR - POWER AMPLIFIER ADDED



MASTER OSCILLATOR - WITH MULTIPLIER AND POWER AMPLIFIER

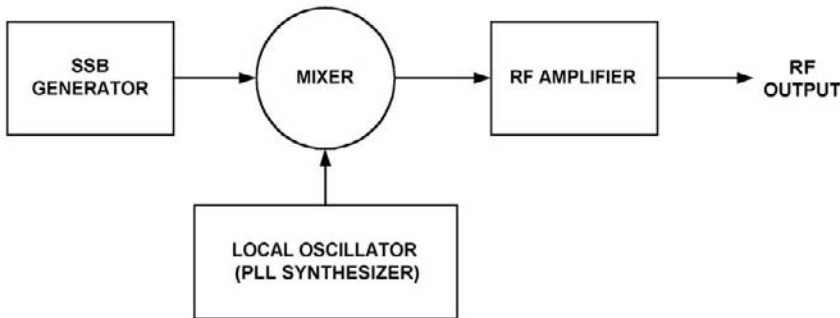

HETERODYNE MIXER WITH RF POWER AMPLIFIER

may be coupled to the oscillator to apply modulation and/or control output power. This approach has certain advantages and disadvantages:

Advantages: Low cost, simplicity, small potential size, low power consumption

Disadvantages: Poor frequency stability and susceptibility to frequency pulling from changes in antenna characteristics, which are determined by proximity and environmental effects. Oscillators are not easy to modulate without producing undesirable effects. Crystal control is difficult to use without creating undesirable effects. An FM modulation scheme may also produce AM and vice versa. Oscillators may drift with temperature, battery voltage, and so forth. This precludes or makes difficult narrowband operation with sensitive receivers and is best used with wideband modulation modes.

Master Oscillator–Power Amplifier

The master oscillator–power amplifier (MOPA) approach uses an oscillator to drive a separate amplifier, which acts as a buffer and ideally isolates the oscillator from load changes produced by the antenna. In the simplest cases, this may be the output, or radio-frequency power amplifier (RF PA); however, more stages might be used as follows: The oscillator output can be fed to a frequency multiplier stage(s) to multiply the oscillator frequency by a number generally two or three times, but four or even five times is possible with good filtering. A somewhat pessimistic but practical rule of thumb is that a frequency multiplier cannot be more efficient than the reciprocal of the multiplying factor squared. For a doubler, this is 25 percent; for a tripler, 9 percent. This means high-power consumption for the multiplier stages, with no contribution to the output power; however, this approach is time tested and works well, and for many years was a primary approach to HF, VHF, and UHF transmitter design. We use this approach in several projects in this book because it is simple and reliable. The oscillator is only modulated in the case of FM, and this is relatively easy, the AM being removed in the nonlinear multiplier stages. The RF PA, sometimes called the “final,” is modulated in the case of AM (audio or video).

Advantages: Simplicity, reasonable cost, excellent modulation characteristics, and good to excellent frequency stability (especially if crystal control is used). Time-proven approach and useful for reaching high frequencies, up to more than 1000 MHz. By including extra controls, it can be used to make a multiband transmitter if the desired outputs are harmonically related (i.e., integer multiples). For many years, ham radio operators used transmitters in which an oscillator operating in the 160-meter band (1.8 MHz) was multiplied to 3.5, 7, 14, 21, and 28 MHz by switching in or out multiplier stages and tuned networks. Of course, the transmitter required tuning when the output frequency was changed, but this was of little concern because it allowed one transmitter to cover the entire HF spectrum.

Disadvantages: Can be complex, may need several stages if a high multiplication factor (4 times) is needed, can be easily mistuned to wrong output frequencies, and generates harmonics and spurious frequencies that need to be filtered out. Skilled technical personnel and some test equipment may be needed to set up and tune properly. The need for good RF filtering makes small physical size relatively difficult to obtain if high spectral purity is desired. Power consumption is somewhat high relative to RF output, especially in low-power (less than 1 watt) work because of the overhead of the nonoutput-producing multipliers.

Heterodyne Mixer–Power Amplifier

The heterodyne mixer–power amplifier approach uses the principle from superheterodyne receivers in reverse. A signal with the desired characteristics (AM, FM, single sideband, video, etc.) is generated at one frequency called the intermediate frequency (IF). This can be done with a high level of performance because it is generally all done at one relatively low frequency. Excellent, high-performance circuitry and filtering can be used because only one frequency is to be handled. This produces a clean signal. The signal is then mixed with a local oscillator (LO) signal in a mixer, and the mixer output is filtered to suppress all but the desired output signal. The LO can be a crystal oscillator, variable-frequency oscillator

(VFO), or a phase locked loop (PLL) synthesizer. Most modern transmitters use a PLL source for the LO.

This output signal is then amplified in a broadband amplifier to the final output power. Some harmonic filtering generally is necessary, but broadband, no-tune transmitters result from this approach. Bandwidths as great as 1.8 to 1 can be achieved without filter switching or tuning of any kind, and with automatic filter switching the entire HF spectrum (generally 1.5–30 MHz) can be covered with uniform performance. All modern single sideband (SSB) and amateur radio transceivers use this approach, and it is used at VHF and UHF for military and commercial purposes.

Advantages: Wide frequency coverage, broadband, and any type of modulation usable with the proper linear amplifier. Generally, uniform performance over a wide frequency range with no retuning or adjustment.

Disadvantages: High cost, complexity, large physical size compared to other approaches (LSI and VLSI devices and surface-mount technology are a great help here), extensive filtering and sometimes shielding required, linear amplifiers needed for analog modulation schemes, and possibility of spurious nonharmonically related emissions. Careful design is needed to reduce these emissions to a satisfactory level. Generally unsuitable when very small, low-cost, low-power transmitters are required.

Of course, new technologies make more possible in less space and cost. The wireless revolution, with cell phone and digital personal communication services (PCS), has brought many new RF devices that can provide solutions to design problems; however, a kind of “double-edged sword” problem exists here. The trend toward surface-mount and wireless devices has also brought the discontinuance of many good but somewhat large devices (meaning here that you can see and handle them without aid and can work with them without possessing the skills of a fine watchmaker) that are “perfect” for the experimenter and hobbyist. These devices are not technically obsolete, just too large for surface mount. In some cases, the chips or transistors have just been repackaged in surface-mount packages.

One large manufacturer (Motorola) has discontinued practically all of their discrete RF bipolar 7.5- and 12-volt power devices in TO-92 and X style packages, many of which are industry standards and excellent experimenter devices. Another company (Microsemi) is picking up the manufacture and supply of many of these devices, for aftermarket and replacement service, but the trend is disturbing from an experimenter’s viewpoint. Although you can work with many of the “larger” surface-mount packages with the aid of small tools, somehow it just isn’t as much fun. A very small surface-mount chip component dropped on a carpet is probably lost forever. To reach higher frequencies with good performance, however, and to keep size down, this technology really is the way to go. Surface-mount components have very small parasitic capacitance and inductances compared to traditional through-hole components. It is amazing to see how well surface-mount circuits work at UHF after working with conventional components. Fewer parasitic effects and the improved bypassing and reduced stray coupling achieved make for better operation, with far fewer UHF “dogs.”

For experimenters and hobbyists, working in the 500–1300 MHz range with surface mount can be as easy as working in the 100–200 MHz VHF range with conventional components. Of course, the price paid is the necessity of working with very small components. In this book, surface-mount components are used together with

conventional through-hole components in several projects. We assume some familiarity with RF and audio circuitry and that you have built a few circuits before. We also assume that you are computer literate to the point of being able to save and recall files and look things up on the Internet. Although it is not totally necessary, it also would be helpful for you to be able to write some simple assembly language programming software for microprocessors, such as the 8051, or the Microchip PIC chips, such as the PIC16F84 or similar devices.

Many of the newer VLSI devices, such as frequency synthesizers, require serial programming inputs that are most easily generated with microcontrollers and microprocessors. If you decide to use these new chips for your projects, you will have to be somewhat comfortable with microcontrollers. This is the direction RF technology is going in—smaller size, higher frequencies—and if this phase of electronics is to be your hobby, you may as well get used to it. Alternate approaches are to take up antique radio repair, audio, computer programming, or gardening instead. In addition, you should get a ham license if you do not already have one. The days of struggling with Morse code are gone, and a code-free technician class license will open many doors to interesting opportunities to put transmitters on the air, get practical experience, and meet new people. If you can understand the contents of this book and learn a few rules and regulations, you are well on your way to obtaining a ham license. Check out the American Radio Relay League's (ARRL) Website at www.arrl.org for details on obtaining a ham license.

Some of the projects in this book use what we call the “new technology approach,” where LSI IC devices perform many of the functions in a system. An example are the frequency synthesizer IC devices used in our FM stereo transmitters. This approach allows a drastic reduction in the component count. The new technology approach can be a little too “black box,” and many circuit points and waveforms are inaccessible for tests and observation. The necessary components may be available from only one or two manufacturers and can be discontinued at any time because of poor sales records, corporate mergers or buyouts, or other factors not related to technical performance. This scenario renders the project obsolete because parts can no longer be obtained. A 28-pin LSI IC offers little to teach about its internal workings, whereby a discrete circuit can be observed, tested, and probed to satisfy your curiosity. New technology can tie you to a manufacturer and a specific approach and offers little in the way of education about how things work at a fundamental level.

Today, people seem to be becoming more and more dependent on increasingly sophisticated devices of which they have less and less understanding about how they work. For example, as children, we used to use a needle and a paper horn to extract sound from a record on a turntable. Try to do this with a compact disc. We made radios from a razor blade, a safety pin, and scrap wire, and with the aid of a 50-foot antenna and a pair of earphones, could pick up local radio stations. Try this with FM stereo. The basics were easier to learn with the old technology because we could “get to it” hands on. It wasn't hidden in an expensive little box containing a bunch of chips. If this trend continues, and it probably will, the operation of common household devices and appliances will be as big a mystery to most people as the existence of life after death. Yet, basic principles still and always will apply, and one of the best ways to learn basics is through observation and experimentation.

It is hoped that the projects in this book will help provide this opportunity. Some of the projects use what we call the “old technology approach,” where most circuit functions are performed by discrete semiconductors. The ATV transmitter for 440

MHz is an example. A crystal oscillator drives a multiplier chain and power amplifier, and a video amplifier built with discretes serves as the modulator. The “old technology” might be better called the “traditional approach” because nothing is really that old. The 440-MHz ATV transmitter could have been built 25 or 30 years ago and performed just as well, assuming that the same components were available then; however, it has the advantage of being easy to understand and work with, and it is relatively immune from obsolescence as a result of part discontinuances. Industry standard parts that are generic in nature are used, and many alternate replacement transistor devices exist that will function in each stage. Considering the surplus market availability of parts, this design will probably still be useful 25 to 30 years from now as a ham or experimenter project. But the “new technology” approach will likely be obsolete by then because some of the required parts undoubtedly will have been discontinued years before. We could have used a PLL IC device, microprocessor, and integrated RF power module, but why bother? This application doesn’t need any of it and can be simply implemented with traditional “old technology.” The basic needs and requirements do not necessarily change with time, only the implementation methods.

Therefore, traditional approaches still have merit as teaching aids and in simple applications where freedom from obsolescence and easy serviceability by technicians without specialized training are important. This is especially true in developing nations and remote areas, where sources of supply are scarce or nonexistent. So we make no apologies for the “old technology” approaches in some of the projects in this book. Not all of us are engineers or work for large electronics companies, or know someone who does. By the way, vacuum tubes are still being manufactured in Russia, China, and other nations and are in demand in some parts of the world. A vacuum tube radio or TV can be fixed with little more than a voltmeter and schematic. Try this with a solid-state LSI TV or a modern stereo receiver. If you personally haven’t seen it or done it before, any type of “old technology” is new technology to you because you probably know nothing about it. We also find it amusing that some of the critics of old technology have problems repairing a simple transistor radio or even a table lamp. We hope that the projects in this book will be a good learning experience for the builder.

This Page Intentionally Left Blank

2. Basic Building Blocks

Low-power transmitters are made up of the same basic circuits as any other transmitters. Some of the circuitry, though, such as modulators, power supplies, and power amplifiers, differ in size and operating voltages and currents. Generally, certain features found in larger transmitters, such as metering, safety and protection circuits, modulation limiting, and other monitoring functions, may be omitted or are provided in simplified form. Safety and protection are usually not issues because the power is too low to result in damage to components under fault conditions, and operating voltages are 1.5 to possibly 24 volts, with 6 to 12 volts being the most commonly used DC supply voltages. Ten watts of RF output would mean about 1 to 2 amps at 12 volts, so the current levels are not high either; however, at power levels of 1 watt, painful RF burns to the skin are possible, and even lower powers may be hazardous under certain conditions, but for most Part 15 applications, we are working with a few milliwatts at most.

Solid-state circuitry is almost universally used, but some experimenters may work with vacuum tubes, especially at the 1- to 10-watt RF power levels, which pose a shock hazard from the 100- to 250-volt plate (B+) supplies necessary for vacuum tube work. In this book, we are not concerned with vacuum tubes, but we mention them anyway because they still have some application in transmitter work. At very high RF power levels (1000 watts or more), they are still considered by many engineers to be the technology of choice. In the areas of reliability, fault tolerance, efficiency, physical size, and cost, vacuum tube technology still has the edge for high-power RF work. A 1000-watt vacuum tube RF amplifier can generally be made smaller, lighter, and cheaper than a 1-kW solid-state amplifier because no bulky heat sinking is needed for the transistors.

The basic building blocks to be discussed are as follows:

- Oscillators
- Amplifiers
- Multipliers
- Modulators
- Frequency synthesizer (PLL) circuits

These components are discussed regarding their application in low-power transmitters and their relative merits and drawbacks. For detailed theory of these circuits, we refer you to any good reference text on the subject.

Oscillators

Oscillators are necessary in any low-power transmitter because they are a means for generating the necessary RF signal. Oscillators come in many forms, but we are

Build Your Own Low-Power Transmitters: Projects for the Electronics Experimenter

mainly concerned with those suitable for RF signal generation at frequencies higher than 100 kHz. A good oscillator—as far as low-power transmitter use is concerned—has the following desirable characteristics:

1. *Good frequency stability:* Ideally, temperature and voltage variations, together with inevitable circuit component tolerances, should not have too serious an effect on the oscillator frequency. Only certain components should affect the frequency of oscillation. The load placed on the oscillator should not change or “pull” the oscillator frequency.
2. *Adequate power output:* Signal output should be adequate to drive the load or following stage, even at the minimum expected supply voltage. The oscillator should start up reliably at low supply voltages and temperatures.
3. *Spectral purity:* This means that the oscillator output should have a single, monochromatic spectral line, with absolutely no energy present at any frequency other than that desired. This characteristic can be related to frequency stability.
4. *Ability to be modulated:* Direct FM is often used, in which an audio or other modulating waveform is applied to a varactor diode, which is connected to the frequency-determining elements in the oscillator circuit. This requirement conflicts with those of stability and purity, and in a specific application, design compromises must be made.
5. *Simplicity:* To keep size and cost down, circuits with as few components as possible are preferred, but other performance requirements may dictate the exact circuitry needed.

Frequency-determining elements are those elements in an oscillator circuit that affect or are intended to determine the oscillator frequency, such as an LC tank circuit or a crystal. These elements must have as high a Q factor as possible. The stability of an oscillator is proportional to the rate of phase change with frequency in the oscillator loop, which consists of an amplifier and a feedback network. Stability is often broken down into long term and short term. Long term is, for example, the ability of an oscillator to maintain its set frequency within satisfactory limits over a long period, such as a week, month, or year. Component aging and long-term physical changes in components determine this ability. Short-term stability consists of such factors as warmup drift, drift caused by temperature changes normally incurred during operation of the circuit, on-off cycling, and so forth. Timeframes of up to one day would be applicable. Oscillator phase noise consisting of frequency changes of very short duration, less than 1 second, can be considered as a very short-term drift.

All oscillators exhibit phase noise caused by spurious modulation of instantaneous frequency by various forms of noise effects in circuitry and individual components, such as flicker noise in transistors and the inevitable thermal noise in resistors. This noise may have spectral components out to several hundred kHz or more, but it generally falls off with increasing frequency, and a typical figure might be 60–100 dB down or better at 1 kHz away from the main frequency. This performance figure is normally specified in dBc, meaning the number of decibels the noise power is down with respect to the carrier (oscillator frequency), generally at 1 kHz or another specified frequency away from it, as measured in (usually) a 1-hertz bandwidth. The better oscillators in this regard have high Q frequency-determining elements that

dominate the loop characteristics. Crystal-controlled oscillators are the best, and simple RC oscillators, such as NE555 timers, are the poorest.

In low-power transmitter work, crystal control is preferred, either directly in the master oscillator or indirectly as in a PLL synthesizer. This is especially true if narrowband modulation is to be used, such as AM, narrowband FM, or single sideband (SSB). These emissions have occupied bandwidths of 15 kHz or less. The receiver should ideally have no more bandwidth than necessary for the particular type of modulation, for the best signal-to-noise ratio, which translates into the best range, lowest usable transmitter power, and smallest antennas, all of which are important considerations. This has a direct bearing on the frequency stability requirements for the low-power transmitter. Typical transistor LC oscillator circuits that would be used in low-power bugs and surveillance transmitters, and also in consumer-grade AM and FM receivers, might have an overall stability (combined long and short term) of 0.1 percent or so, and as poor as 1 percent of the nominal (center) oscillator frequency. For an AM receiver and a small surveillance transmitter operating at, say, 1500 kHz, this would be 1.5 kHz. Because the AM receiver has about 10 kHz of bandwidth, a transmitter drift of 1.5 kHz would at worst cause a little audio distortion, depending on the exact shape of the receiver bandwidth curve (i.e., sharp or broad response). This problem is not serious and is easily corrected by a slight retuning of the receiver, if this is possible. A poor transmitter oscillator with 10 or 15 kHz of drift would be a nuisance, but the signal would still be easily found because at worst it would have moved up or down one channel, as long as the channel it drifted into was unoccupied by a strong station.

If the transmitter was operating at, say, 150 MHz, however, this would be another story. The transmitter now may have moved as much as 150 kHz or even 1.5 MHz with a poor design. The signal would now be much harder to find initially, and once found, it may keep wandering around, making it difficult to keep the receiver tuned to it. This would be a pretty bad situation when a recording is being made or in any other situation in which signal interruption is not allowable. In this case, crystal control of the transmitter frequency would be mandatory.

The better free-running LC oscillators can achieve about 0.01 percent short-term stability (i.e., 1 part in 10000). This stability is adequate for standard AM and short-wave broadcast reception over the 150 kHz to 30 MHz range. This was also typical of the AM ham receivers, transmitters, and variable-frequency oscillators (VFOs) built in the 1950s and early 1960s, but it proved to be inadequate for serious continuous wave (CW) and SSB work. With careful design and choice of components, voltage and temperature compensation, and rigid mechanical design with temperature-compensated corrected materials, somewhat better than 1 part in 100,000 (0.001 percent) can be achieved. This feat of engineering is not often achieved, though, and is almost impossible in any type of transmitter we will be working with. Good amateur radio VFO designs for SSB use achieve, after a warmup period, 100 Hz short-term stability at frequencies typically in the 5-MHz range. This is a stability of .002 percent. In modern ham gear (post 1985), this stability is still not very good, especially when digital frequency readouts to 10 Hz are commonly used and expected. A mediocre crystal oscillator circuit, on the other hand, can easily perform an order of magnitude better than this in the area of short-term stability.

In the previous example, to get a short-term stability of 1.5 kHz at 150 MHz, we would need 1 part in 10 million, or .0001 percent stability. This goal is easily

Build Your Own Low-Power Transmitters: Projects for the Electronics Experimenter

achieved with a crystal and a properly designed oscillator circuit. Modern scanner receivers cover up to as high as 2000–2500 MHz, and frequencies this high are increasingly being used for narrowband work. Therefore, high-frequency stability is important. The use of PLL techniques allows variable-frequency operation with one or sometimes two fixed crystal oscillators. Therefore, free-running oscillators should be used only in low-power transmitter work, where the occupied bandwidth of the transmitted signal is 0.1 percent or more, and if some frequency drift can be tolerated. These instances include garage door openers, FM wireless mikes, and certain toy applications. A few projects and circuits in this book use this approach. Some representative oscillator circuits that have application in low-power transmitters are shown in Figure 2-1.

Figure 2-1
Typical Oscillator
Circuits for Low
Power FM Trans-
mitter Use

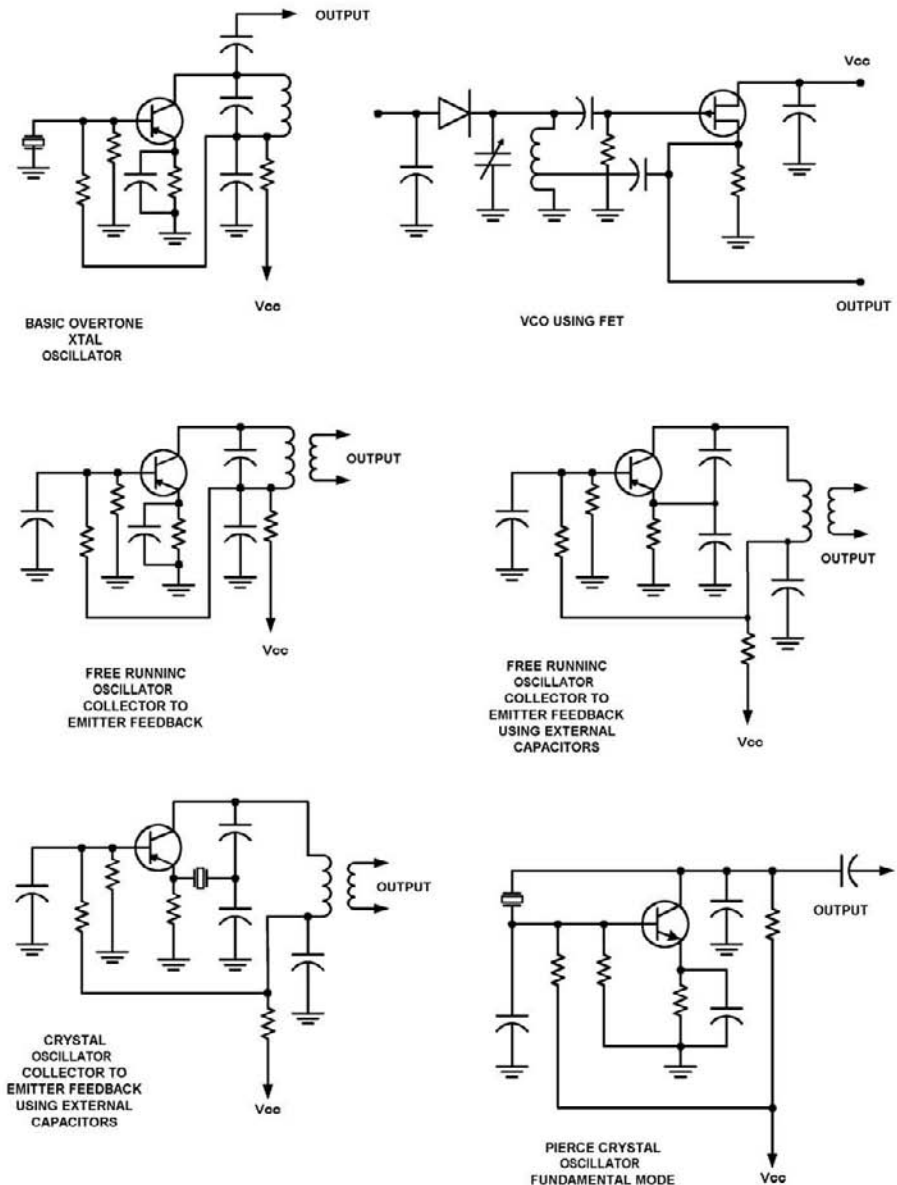

Amplifiers

Amplifiers used for low-power transmitters may be either of IC or discrete transistor construction. For most small low-power transmitter applications, small-signal bipolar and FET discrete transistors of the appropriate type, having F_t ratings of 3 to 10 times the operating frequency, are adequate. Modern RF silicon NPN types come in both conventional plastic, metal, and surface-mount packages, and even audio types sometimes have F_t ratings of more than 100 MHz. We use the 2N3563 for many RF applications, but many other types, such as the 2N918, 2N2857, 2N5179, and 2N2369, are also usable. These types have been around for more than 20 years, are widely available from the surplus market, are inexpensive, and have been manufactured by several sources. Many other types are suitable, but these are our personal favorites, not because they are necessarily the best, but because of our long experience with them. For amplifiers that must supply a little more power, the 2N3866 and 2N5109 are excellent, and for UHF, the MRF559 X lead package is good for a half-watt at 800 MHz, or the BFR96. In addition, higher-powered TO39 types, such as the 2N4427 and MRF630/SD1444, are good for more than 1 watt at 150 and 450 MHz, respectively, and are easy to work with, with no fragile beryllium oxide package to worry about damaging.

RF power ICs (actually monolithic modules) that take all of the work out of designing RF power amplifiers are available from several manufacturers. They are flat assemblies that operate from popular supply voltages and frequency ranges, and some have provisions for RF power output control, which can be used for amplitude modulation. They normally must be mounted on a heatsink; however, these modules generally are designed for specific frequency ranges and power levels, and using them may tie you down to a specific manufacturer. In case of failure, they are more expensive to replace than a discrete RF device, and the manufacturer may discontinue them, with no future availability of a replacement unit. They are useful, but they have associated tradeoffs, both in design freedom and future availability.

Today, RF transistors with 500-MHz F_t ratings are inexpensive, and ratings of more than 5 GHz are common, with devices available to 25 GHz and higher. Typical 3–5 GHz types in this category are the MRF901, BFR90, and the NEC25139 dual-gate FET. It does not pay to use a transistor with a much higher frequency rating than you need, and this practice may actually cause you trouble because of parasitic effects. It is common to have a 5-GHz transistor generate spurious UHF signals because of stray inductances and capacitances of common components intended for use at lower frequencies. We had an amplifier that was intended for 220 MHz generate a 1-GHz signal (1000MHz), with the 220-MHz tuned circuit having no effect whatever. The collector-tuning capacitor had a resonance at 1 GHz, with the emitter inductance and collector emitter capacitance of the transistor acting as a feedback network at 1 GHz. This problem was cured by using chip components for the capacitors, but without a spectrum analyzer, the problem would not have been so easily spotted. A 500- or 1000-MHz transistor (2N3563) did not exhibit this effect and worked fine.

Several IC devices are sold for RF amplifier use. The Motorola MC1350 is an 8-pin IC that works well up to 100 MHz. The MAR-1 (Mini Circuits Corporation) is a monolithic microwave IC (MMIC) that works well if limited output power is satisfactory, and is good to 2000 MHz with gains of around 8–17 dB, depending on frequency. The ERA series from the same company works up to 8–10 GHz. These ICs use a 4-pin X package and a single 5- to 12-volt supply, and are 50 ohms in and out,

simplifying interfacing. For the common 10- to 20-dB gain stage usually needed, however, ICs offer little or no advantage and save very little. They are best used when special requirements or very high RF gains are needed that are unavailable from a single amplifier stage using discrete transistors, or when several functions must be performed, such as in an FM receiver limiter-detector or a multistage gain-controlled IF system that must supply automatic gain control (AGC) AFC, meter and squelch functions, and so forth. ICs of this type often provide performance far superior to an equivalent discrete component design, with much less circuitry, fewer adjustments, and simpler setup and testing. They may also offer “deluxe” features that are not easily supported by traditional discrete component designs, such as logarithmic meter output for signal-strength monitoring, synchronous AM detection, digital volume and tone controls, multistandard operation capability, and the opportunity for microcontroller interfacing.

Many RF devices in conventional TO92 plastic and X lead packages are being phased out by their primary manufacturers because they are being replaced with surface-mount types; however, other manufacturers are picking up many of these discontinued types, so they will be available in the future and can be obtained surplus. There will always be a need for these devices for maintenance and replacement purposes because they have become “industry standards.” The 2N2222, 2N2905, and 2N3055 devices, for example, which date back to the 1960s but have been improved, are still useful in new designs and are still popular for experimenters. In many regards, some transistors are fairly “generic” because proper circuit design using feedback techniques can cancel the effect of wide variations in parameters. With 10 or 20 well-chosen devices, you can do almost anything you want to. A few representative RF amplifier circuits are shown in Figure 2-2.

Multipliers

Frequency multipliers are basically nonlinear circuits that produce harmonics of the operating frequency. A filter, which usually comprises tuned circuits, picks out the desired harmonic and rejects the input frequency and all other harmonics. Multipliers are normally used to double or triple the input frequency, but higher orders of multiplication are often performed. Multipliers may consist of discrete transistor amplifier stages, Schottky (hot carrier) diodes, varactors, and snap diodes. In low-power transmitter work, the discrete transistor stage is often used. The output network is generally a double-tuned circuit tuned to twice or three times the input frequency. This allows higher frequency output from a lower-frequency oscillator and acts as a buffer to reduce interaction of the load and oscillator stages.

A multiplier stage must be driven into nonlinearity to produce harmonics, and the output power is often no more than the input power, and sometimes less, especially when multiplications of 4 or 5 are performed. A multiplier stage should be driven from a low-source impedance, both at the input and output frequencies, for best performance. RF efficiency (the ratio of RF out to DC power input) tends to be poor, with 20 percent for a doubler and 5–10 percent for a tripler being typical. Some circuit approaches use specific transistors that exhibit a collector “varactor effect,” and these circuits exhibit much better efficiency as frequency multipliers. These circuits use idler-tuned circuits in the input networks and work well when properly tuned, but they are prone to spurious outputs and instability. A spectrum analyzer is necessary when working with these circuits. In the case of multipliers that are strictly

FIGURE 2-2
Representative RF
Amplifier Circuits

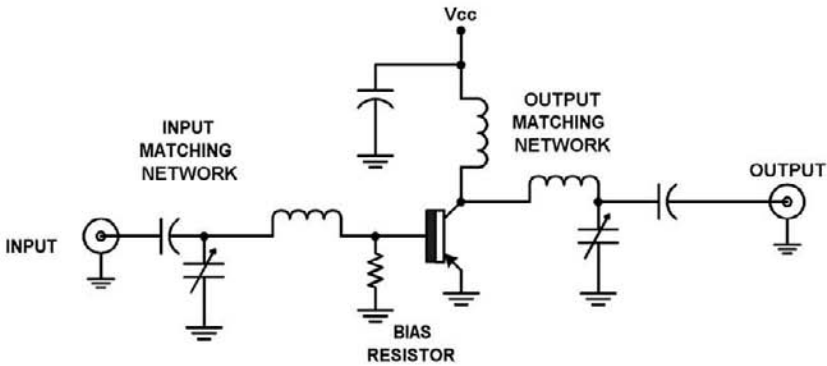

BIPOLAR TRANSISTOR RF STAGE CLASS C

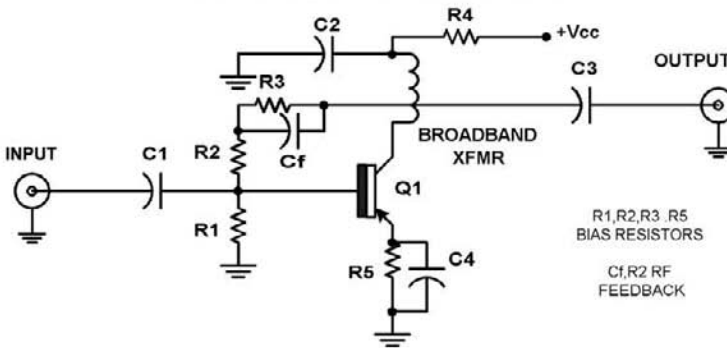

LINEAR BROADBAND RF STAGE

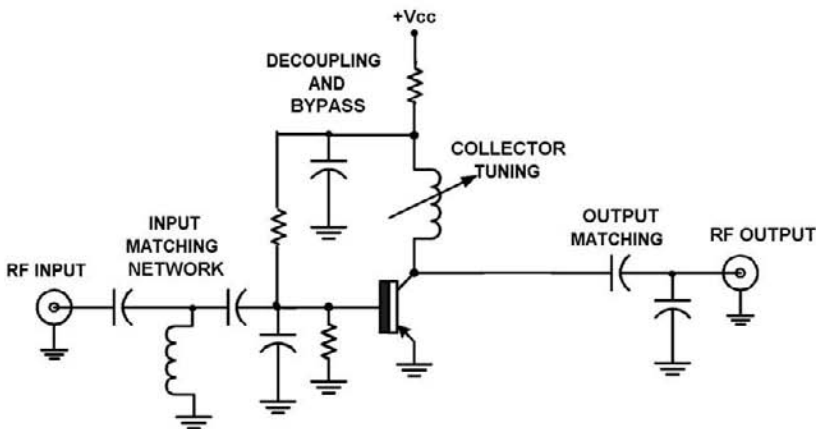

LINEAR NARROWBAND RF AMPLIFIER STAGE

overdriven amplifiers, however, the rest of the (unwanted) output is dissipated in the transistor and output network loss resistances as heat.

In addition, the fundamental component appears in the output along with unwanted harmonics and is, along with lower-order harmonics, usually larger in amplitude than the desired harmonic. The output network must reject

everything except the desired harmonic. Double-tuned circuits are a must for doublers and triplers, with triple- or quadruple-tuned circuits often needed for higher orders of multiplication. Therefore, it may be better to use two doubler stages instead of one quadrupler. The same transistors that are used for RF amplifiers can be used as multipliers, and output frequencies approaching the f_t of the transistor can be produced with reasonable efficiencies. You should not use frequency multipliers to produce power outputs of more than 50 mW, and less than 20 mW is even better, to reduce levels of unwanted harmonics. You should never use the output stage of a transmitter as a frequency multiplier—as was often done back in the vacuum tube days—because this is asking for problems with spurious emissions. Representative multiplier circuits are shown in Figure 2-3.

Modulators

A modulator, for our purposes, is a circuit used to superimpose information on a carrier waveform. The amplitude of the carrier (usually, but not necessarily, a sine wave) may be modulated with this modulating waveform (AM or SSB), or the instantaneous frequency (frequency modulation, FM) or phase (phase modulation, PM) of the carrier wave can be modulated with it. Another possibility is that the carrier wave may be simply turned on and off (pulse or CW). Combinations and variations of these methods may be employed as well. The modulating waveform can be audio, video, digital pulses, or combinations of these methods. In most low-power work, audio is used, and video is used for TV transmissions.

Digital waveforms are used for control purposes or data transmission and for digital audio and video. In addition, a hand-operated key switch may be used to turn on and off the carrier to form Morse code characters, the oldest form of digital communication, and the only digital communication method readable by humans without special equipment. Morse code is one of the best weak-signal communications modes in use, with performance exceeded only by sophisticated digital techniques such as binary phase shift keying (BPSK) requiring sophisticated equipment and phase coherent transmitters and receivers operating at slow data rates.

Morse code still gives the best results for weak-signal long-distance communication with low-power equipment. Amateurs have made two-way intercontinental contacts with 100 mW or less power on the HF bands, between 2–30 MHz unit cost of all modulation modes using Morse code (CW). Despite the easing and elimination of the code requirements for a ham license, Morse code is still often used and is popular, often getting through when all else fails. The ability of Morse code to use 100-Hz receiver bandwidths really helps because it allows signals 10–20 dB weaker than SSB voice to be plainly audible. It is not and will never be obsolete, contrary to what anyone says, until the day we humans are obsolete.

Modulators for AM are generally audio amplifiers that superimpose their output on the DC supply to the output amplifier or another amplifier in the transmitter signal path. The instantaneous voltage supplied to the stage by the modulator determines the output of that stage. In many cases, the DC supply to the RF stage is in series with the modulator output. The modulator must provide a power output (audio or video) equal to half of the DC input to the RF stage being modulated, for 100 percent modulation. For low-power transmitters, powers of at most a few watts are needed, and simple transistor or IC audio amplifiers make good audio AM modulators. Video modulators for conventional (AM) National Television Standard Com-

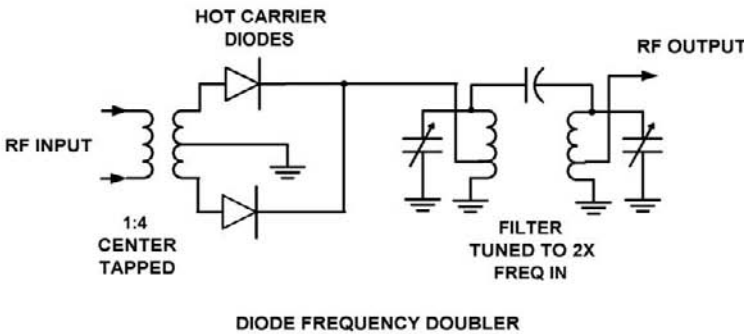
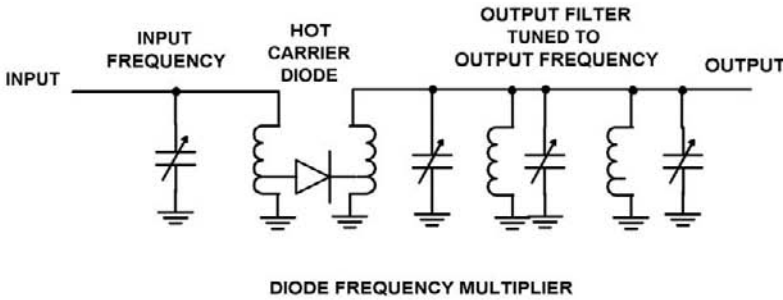
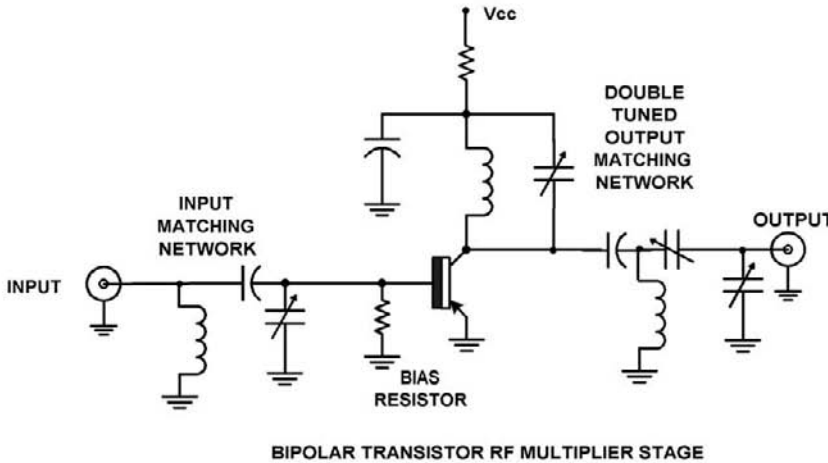

Figure 2-3
Representative
Frequency Multiplier
Circuits

mittee (NTSC) video need to handle bandwidths of up to 4–5 MHz, and most audio ICs will not handle this high of a frequency, so a discrete audio amplifier design using high-frequency transistors must be used. Clamping circuits are also needed to ensure proper DC video-level relationships because the sync pulse tips must always produce constant maximum transmitter RF output levels, regardless of the rest of the video waveform. In addition, support is needed to add a low-level audio subcarrier (FM) at 4.5 MHz if audio transmission is needed.

Frequency modulation is generally accomplished with a varactor diode connected to the frequency-determining elements of a low-power transmitter. In addition to a

varactor (also called varicap) diode, several other approaches, such as a reactance modulator, are possible but are seldom used in low-power transmitter work and therefore are not mentioned. The varactor diode method cannot be beat for simplicity and reliability. The audio, pulse, or video waveform is coupled to the varactor through RF isolation components (RF chokes or high-value resistors). This setup varies the instantaneous capacitance of the diode, causing the frequency of the oscillator circuit to change in accordance with the modulating signal. FM can be narrowband (deviation 15 kHz or less), such as commercial two-way radio and 2-meter amateur FM or wideband (25 kHz or more), such as in commercial FM audio broadcasting.

The deviation is a measure of how much the carrier frequency varies under modulation and must not be confused with the modulating frequency, which determines how often the carrier frequency is varied as a result of modulation. The ratio of the deviation to the modulation frequency is called the *modulation index* and is often designated by the Greek letter β (beta). The values of β vary instantaneously. In an FM stereo transmission with a 1-kHz audio signal and a 75-kHz deviation, β is 75. Increasing the audio modulation to 15 kHz produces a β of 5. The larger the value of β , the better signal-to-noise ratio that an FM system can potentially produce compared to an equivalent AM system. This is called the *FM improvement factor*, but it is only valid at signal levels over a certain threshold, in which the carrier-to-noise ratio of the received signal is 7–10 dB, depending on system design and other factors. Below this level, AM is superior, but in practice, we make sure the received signal is above threshold at all times, so FM is quieter and cleaner sounding than AM, as any radio listener knows. FM modulation is also used by satellite television broadcast services, for microwave video links, and for some amateur TV work, especially in Europe, on the 23-cm (1300 MHz) band and higher. Deviations of several MHz are used for video, with carrier frequencies usually in the microwave range (more than 1000 MHz).

SSB is basically AM with the carrier and one sideband removed, leaving a signal whose makeup can be likened to an audio signal arithmetically shifted to a much higher frequency. Most SSB work is done in the HF range, with some in the VHF and UHF bands, mainly amateur and military. Because the carrier is not transmitted, it must be reinserted at the receiver. Either the lower sideband (LSB) or the upper sideband (USB) can be transmitted, and it is possible to use both for two different audio channels (independent sideband [ISB]). In addition, audio subcarriers can be used for even more audio channels. The sidebands are RF just like the carrier and therefore do not need the carrier to be transmitted. The carrier has two-thirds of the total power of an AM signal with 100 percent modulation, and the remaining one-third is equally divided between the LSB and USB. Therefore, each sideband has one-sixth the total power.

A 40-watt carrier AM signal has 10 watts in each sideband, and because only one sideband is needed, a 10-watt SSB transmitter would be equally effective as a 40-watt AM transmitter. The advantage gained here is 6 dB, and because only half the receiver bandwidth is needed, another two times (3 dB) advantage is gained at the receiver, for a total of eight times advantage. A 40-watt SSB transmitter would theoretically have an eight times advantage (about 9 dB) over a 40-watt AM transmitter, and is smaller because of the elimination of the required heavy AM modulator. Therefore, SSB has largely replaced AM in HF communications work; however, SSB poses some strict frequency stability requirements. To sound natural, the carrier frequency must be reinserted within 50 Hz of the original, with 10 Hz preferred. As

the carrier frequency increases, this goal becomes increasingly difficult to achieve, and the extra circuitry needed to generate and receive SSB, together with special filters to remove the unwanted sideband, limit audio quality and frequency response.

AM is still used for broadcasting where strong signals are normally available and reasonable audio quality is important, and simple low-cost receivers must be made available. AM is still used at VHF (118–136 MHz) and UHF (225–400 MHz) for ground-to-air communications by the military and commercial airlines and is universally used worldwide for this purpose. It also avoids the FM “capture effect,” where a somewhat strong signal may completely suppress another signal that is only 6–10 dB weaker. This situation would be undesirable in aviation communications because a weaker emergency signal or a signal from an aircraft, say, 10–20 miles out from the airport could be totally suppressed by a stronger signal from an aircraft on downwind or final approach. The air traffic controller (ATC) could be totally unaware of and miss a transmission from a large jet airliner carrying a hundred or more passengers, or from another aircraft in trouble. This situation could obviously result in a serious accident. With AM, the ATC still hears that someone else is attempting to communicate, even if the message is garbled or unreadable, and they can request another transmission. This is a good reason to stay with AM. (SSB is covered further in a later chapter because it is a rather complicated subject.)

Frequency Synthesizer (PLL) Circuits

Frequency synthesizer circuits are feedback servo loops in which a voltage-controlled oscillator (VCO) generates a signal whose frequency is locked to a fixed reference signal (see Figure 2-4). A signal sample from the VCO feeds a frequency divider circuit, which can be made to have a fixed or variable divide ratio (generally called N) and is compared to a crystal oscillator in both frequency and phase. This is done with a frequency and phase detector, whose output can go in either a positive or negative direction. The output—a DC voltage at lock—controls the VCO to achieve a steady-state detector output. Because the divider can be made variable, the VCO frequency varies and equals the reference frequency multiplied by N , which can have almost any value, and frequency resolution equals the reference frequency. Therefore, if the reference frequency is made 1 kHz, and the value of N is 10000, the VCO will produce a 10-MHz signal. If N is increased to 10001, the VCO output will be 10001 kHz.

All of the divider and phase detector circuitry, and often the reference oscillator circuitry, is contained in an LSI IC chip, and surprisingly few components are needed to build a simple frequency synthesizer. Motorola makes chips specifically designed for this purpose, some operating as high as 2 GHz. The VCO design is critical to good performance. Because this is a feedback loop, loop constants must be carefully chosen in the same manner as any other feedback system. In order to achieve low-phase noise, good spectral purity of output, and stable lockup with reasonable settling times (the time it takes for the frequency to settle within specified limits), some design decisions and compromises must be made.

The programming of the variable divider and the reference frequency is generally done via digital logic lines going to the synthesizer chip. Data may be in parallel format, such as in the Motorola MC145151-2, which allows easy programming via logic levels that can be obtained from manually set external switches or a microcontroller. Data may also be in serial format, which vastly reduces the number of data

Figure 2-4
Basic PLL Frequency Synthesizer System

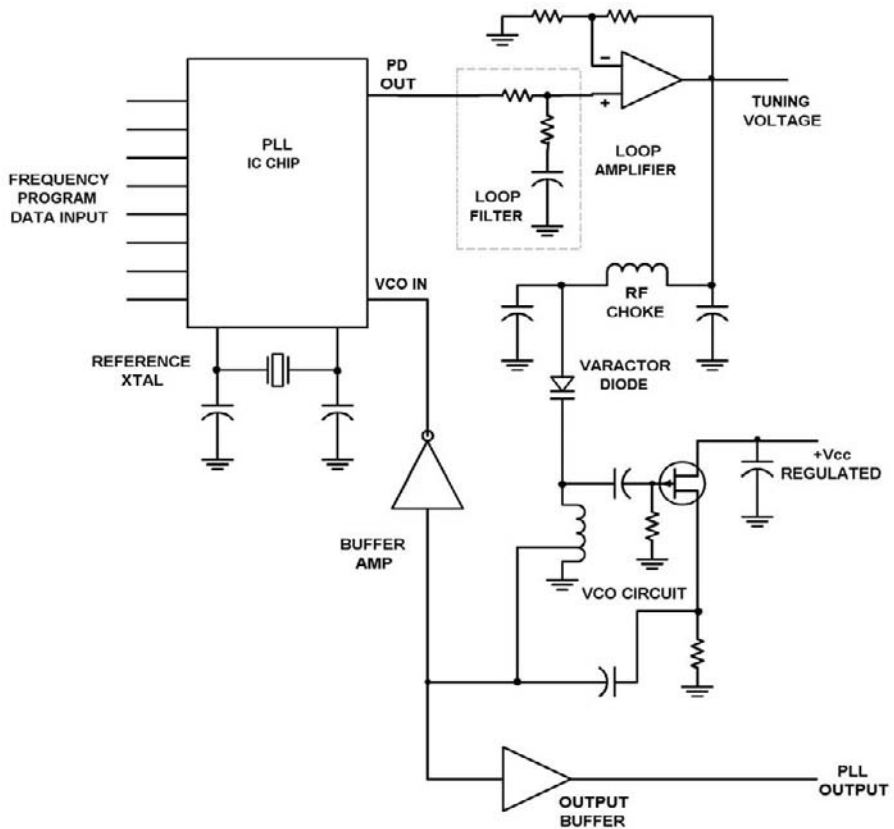

lines to the synthesizer chip to only three—a clock, data, and a chip enable line. The Motorola MC145170-2 is an example of this kind of PLL synthesizer chip. Although requiring a microcontroller to interface to it, this chip results in a simple synthesizer with little circuitry. A microcontroller such as an 8051 or 8751 type or a PIC chip such as the 16C84 or 16F84 can easily provide this functionality and still have plenty of room left to manage the digital display generally used with a synthesizer and perform other overhead tasks. The serial approach using a microcontroller is therefore preferable, and most of the commercially available PLL synthesizer chips seem to use this approach. It is also possible to generate the required serial data in a PC and use its serial port to program the synthesizer, allowing computer control of the synthesizer frequency of the receiver or transmitter, while providing a display of frequency on the monitor screen, assuming the appropriate software is installed. Cards with wideband receivers covering 500 kHz to 1300 MHz are available for installation in your PC and contain a synthesizer chip similar to the ones previously mentioned.

A PLL chip may also be set up to act as a frequency multiplier, enabling elimination of a discrete transistor multiplier chain. The Motorola MC13176 one-chip transmitter does just this, and allows a crystal at $1/32$ nd of the desired output frequency to control a VCO operating in the VHF or UHF band. If a transmitter at, say, 440 MHz

is wanted, you can use a crystal at 13.75 MHz, add a few components, and get a few milliwatts at 440 MHz. An FM and an AM modulator is built in, allowing production of a modulated signal that only needs to be amplified to a suitable level for transmission. The advantages of this chip are its small size, simple operation, and low cost. The disadvantages are its susceptibility to mechanical FM modulation of the VCO caused by physical disturbances of sensitive components, low power output, and rapid obsolescence because of discontinuance of the chip by the manufacturer. It is also a rather small surface-mount device that some experimenters may find difficult to use; however, it would make a good small transmitter with crystal stability for surveillance work. This chip and many others that have been introduced for use in wireless devices are nice to experiment with, but we wonder if they will still be available several years from now. These so-called solutions may become problems at some future date. We would not stake our life on any of these chips or make any long-term production commitments unless a second source becomes available. For a unique experimenter project or a limited production throwaway item, however, it makes sense to consider using these chips.

The subject of PLL synthesizers is an extensive one that could occupy an entire book by itself. Our intent here is merely to introduce them, and further specific details must be left to the construction projects in which they are used. A representative circuit is shown in Figure 2-4.

This Page Intentionally Left Blank

3. Simple Low-Power Transmitters for Experimenters

This chapter discusses some basic low-power transmitters that use relatively few components. Some simple applications are a wireless microphone, a baby monitor, an FM room “bug,” a telephone “bug,” and a basic AM transmitter. Note that although these circuits work, they should be considered in the toy class. For any serious purposes, circuits with a few more components and more reliability should be considered. The cost of a small transmitter may not necessarily be too important within reason. For example, the evidence obtained by a small surveillance transmitter might be worth many times its cost. In some cases, the transmitter is considered expendable after it has served its purpose. But for simple experiments, the circuits to be discussed are adequate in most cases. They can be built on perfboard or wired point to point on a piece of copper-clad PC board material, using the components’ own leads for support. This approach is known as “ugly bug” construction, which is useful for experimental work and when only one of a kind is needed. Alternately, you could lay out and fabricate a PC board if desired.

Wireless Microphone

Probably the most basic transmitter is a simple wireless microphone. This device may be used to connect a microphone to an audio or PA system without the intervening cable, which is a hazard in many situations. The wireless mike is a simple transmitter that acts as a one-way radio link to a nearby FM receiver. The output of the FM receiver then feeds the audio or PA system, replacing the wired microphone. Professional-grade mikes of this sort use a crystal-controlled receiver and transmitter operating outside the FM broadcast band at frequencies specifically intended for this service. (Frequencies around 170 MHz are commonly used for this purpose.)

A typical circuit of a wireless microphone is shown in Figure 3-1. It consists of an audio amplifier that feeds audio into the bias network of a free-running oscillator circuit operating in the FM broadcast band. An electret microphone feeds audio into audio amplifier stage Q1. R1 biases the mike and may be varied to suit the mike used. This value is normally specified in the manufacturer’s data sheet, but 4.7 K is a good “generic” value if no data are available for the microphone. Audio is coupled via C2 to the base of Q1, which is biased by R2, R3, and R4 to about 4 volts and 0.5 milliamps. A low-noise, high-gain audio transistor, such as the 2N3565, should be used, but most high-gain, low-current transistors of this nature should work fine. Amplified audio at the collector is coupled through the RC network C3 and R5 to the base of oscillator Q2. Q2 acts as a grounded base oscillator, with feedback provided by C8. R5 and R6 provide starting bias for the oscillator transistor, and R7 provides emitter bias.

Figure 3-1
Typical Wireless
Microphone Cir-
cuit

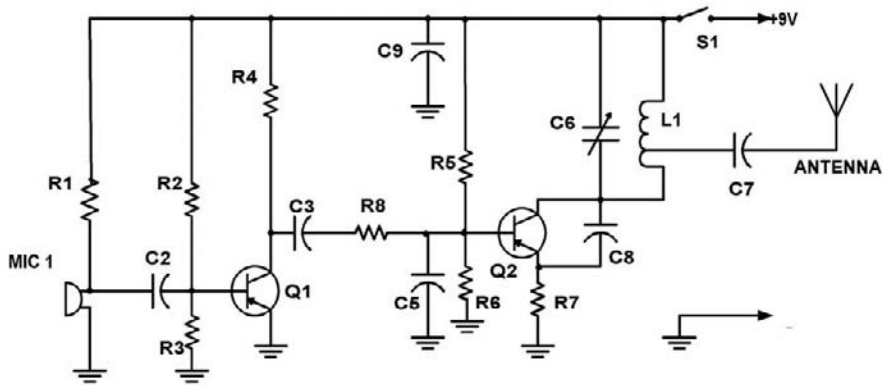

A VHF transistor, such as a 2N3563, 2N5179, or MPSH10, can be used for the oscillator, and any good 500-MHz or better NPN transistor should work, although the modulation characteristics may vary somewhat. Transistors with larger geometries or lower frequency ratings tend to have larger capacitances, with possibly somewhat better modulation capabilities, so do not think that a higher-frequency transistor than you really need will perform better. Tank circuit L1 C6, along with stray circuit and transistor collector-to-base capacitance, determines the frequency of oscillation. The collector-to-base capacitance is a function of collector-base voltage, and this voltage is modulated by the applied audio from R5, causing direct-frequency modulation of the oscillator frequency. Because the oscillator power output also varies with collector voltage, some AM component will also be present, but this creates little harm in this application and is the price paid for simplicity. L1 is typically tapped at 10–30 percent total turns from the RF ground end (V_{cc} rail or C9 in this case). The tap should be as close to ground as possible consistent with good signal output because the closer the tap is to the collector, the more effect the antenna will have on pulling the transmitter frequency. This effect is undesirable and can make the transmitter difficult to set on frequency. C6 is typically a 5- or 7.5-mm polyethylene or Teflon trimmer and is used to set the oscillator frequency. Its value is typically 3–5 pf per meter of operating wavelength.

Because the FM broadcast band is approximately a 3-meter wavelength (100 MHz), C6 would be approximately 9–15 pf. A 10 pf capacitance would be about right because the transistor and stray capacitances will be approximately 2–5 pf. Alternately, C6 can be made fixed and L1 varied via a slug or by stretching and squeezing turns, but this technique might be awkward for some applications, so the variable capacitor may prove to be a more practical method of frequency setting. The antenna is usually made about one-tenth of a wavelength at the operating frequency, and at 100 MHz, is about 30 cm (approximately 1 foot) long, but length also depends on application, mechanical constraints, allowable signal strength for meeting legal or FCC regulations where applicable, and the transmitting range desired. C7 is used as a DC-blocking capacitor and is generally around the same value as the tank-tuning capacitor. These values are only rules of thumb and provide working values for components, but final values should be calculated for optimum performance or determined empirically on working models.

L1 for the FM broadcast band has a value of approximately 0.25 microhenry and is typically several turns of wire wound on a 1/4-inch coil form, or can even be an air

core coil. The coil should be mounted to minimize mechanical vibration and microphonic effects. A 0.25-microhenry coil with 1/4-inch diameter made from #22 wire has about seven close-spaced turns, and if a smaller coil is needed to save space, 13 turns of 1/8-inch-diameter #28 wire can be used. The tap can be either soldered directly to the coil or a small, twisted loop can be brought out at the correct point. Alternately, a few turns of wire wound around the ground end of the coil can serve as a secondary winding, eliminating a tap.

The power supply can be a 9-volt transistor battery or six AA cells wired in series, with an on-off switch to control the DC power. Packaging can be almost any suitable configuration, keeping in mind the need for short leads at VHF in the oscillator circuit. The entire circuit could easily be built into a case salvaged from an old defunct microphone from a junked CB set. Your local CB supplier or repair shop will most likely have a bunch of dead microphones lying around, and you could probably have one for the asking.

As for the antenna, for short ranges, up to 25 feet, you might not even need one because adequate radiation from the circuit may occur, especially if you use a plastic case for packaging the circuit. Otherwise, a short length of music wire may be adequate. (Remember to form a loop or install a bead on the end so you don't poke someone in the eye because music wire can be quite sharp.) You could also use a short, collapsible whip of the kind sold for cell phone replacement use.

Tuneup of this microphone is very simple. Power up the circuit and, listening on a blank or unused FM channel in your area, adjust C6 until you hear a carrier in the receiver, as evidenced by a sudden quieting of the receiver noise as you tune C6 to the channel frequency. Speaking into the microphone should produce some audio in the receiver. If not, check your wiring and the dimensions of L1. This may require some cut and try, especially if L1 has been changed in dimensions from those given in the text. If you have one, a frequency counter coupled to L1 will show the transmitter frequency. If you have excessive audio gain, increase the value of R5 as needed. If audio is inadequate, use a more sensitive electret microphone or install a second audio preamplifier stage similar to the stage used in this circuit.

Baby Monitor

The baby monitor shown in Figure 3-2 is similar to the wireless microphone but has a second audio stage for more gain. This enables lower room audio levels to be picked up by the microphone. This circuit also has a voltage regulator to reduce the tendency of the oscillator to drift in frequency. The audio stage used is a shunt feedback pair to reduce component count and to provide high gain. The gain of this stage is primarily determined by the ratio of R5 to R3 and is 220 in this example. Q1 and Q2 are 2N3565 or similar low-noise audio devices. DC feedback is provided by R11 from the emitter of Q2 to the base of Q1. R2 biases Q1 and R6 set the bias on Q2. C1 couples mike audio to the amplifier stage. C3 prevents degenerative (negative) feedback through R11 by bypassing any signals at the emitter of Q2. Audio is coupled to the modulated oscillator via C2 and R7. R4 is a gain control and is used to set the optimum value of gain for the application.

The oscillator portion is identical to that of the wireless mike, so we do not discuss it in detail. Note that it is fed DC from a resistor and zener diode regulator, R10 and D1, to supply a constant 9 volts to the oscillator. This aids in reducing frequency drift caused by variations in supply voltage. C5 and C6 are RF bypass and noise-filter

Figure 3-2
Wireless Baby
Monitor Operating
at 88-108MHz

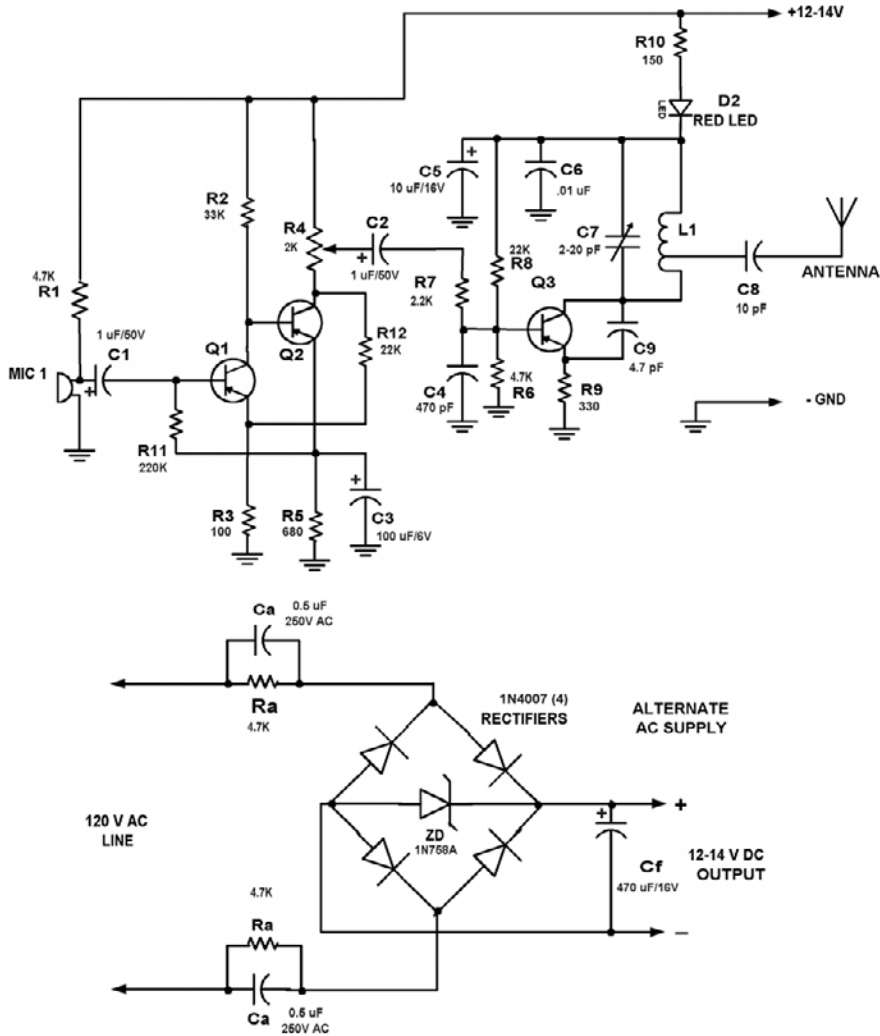

capacitors, respectively. Also, an LED D2 is used in series with R10 as a power-on indicator. The LED uses no extra battery current in this manner. The RF components are identical to the corresponding ones in the wireless microphone. The tuning procedure is also identical to that for the wireless mike. Because this circuit will be used in a room where infants and small children are present, it is battery powered for safety reasons. Use eight AA cells or similar, and because the total current drain is less than 10 milliamperes, battery life should approach 100–200 hours. A power pack made up of eight D cells would last indefinitely long. Use of a wall transformer is not recommended for safety reasons and the possibility of AC hum pickup on the transmitted signal.

Room “Bug”

The wireless microphone could be built using surface-mount or subminiature components and mounted into a 120-volt electrical box installed in a wall, or even

directly on the back of a 120-volt 15- or 20-amp AC receptacle. In this manner, it could act as a room “bug.” As shown in Figure 3-2, the circuit can be powered directly from the 120-volt AC line by using a bridge rectifier and zener regulator, with capacitors if desired instead of resistors acting as current limiters. Only a few milliamperes at 12 volts is needed. In order to limit fault current, it is a good idea to use resistors (or capacitors) in both legs of the AC line. Capacitors should be about 0.5–1.0 ufd and rated for 250-volt AC service. No antenna is needed because adequate RF is being coupled to the power line by stray capacitance to hear on a nearby FM receiver. For 220- to 240-volt operation, use correspondingly larger resistors and smaller capacitance values. About 0.25–0.33 uf at 600 volts AC rating should be enough for this application. A 470 uf capacitor shunting the zener diode provides filtering of AC hum. The use of capacitors results in lower power dissipation, but capacitor physical size may be a problem, so resistors might be more practical, even with the extra heat generated by them.

Telephone Line “Bug”

A circuit for a telephone “bug” is shown in Figure 3-3. Again, the RF portion is identical, but the method of powering the circuit and the audio input circuitry is different. This unit is designed to be directly powered by the voltage available from the telephone line, with audio being fed to the circuit directly from the telephone line. How this is achieved can be seen in Figure 3-3. The circuit consists of a basic VHF oscillator tuned to a frequency in the FM broadcast band. In most telephone systems, a two-wire loop that connects the subscriber to the central office is used, with the loop current around 20 mA and the loop voltage usually 48 volts DC. When the phone is on the hook, it appears as an open circuit, and the full 48 volts is present on the line. (The actual voltage may vary somewhat.)

When the telephone is taken off the hook, the voltage across the phone drops to a much lower value, around 5–10 volts, and a current of nominally 20 mA will flow. Superimposed on this line are audio and tone signals. In addition, an AC ringing voltage of around 100–120 volts at a frequency of 20 Hz may be supplied by the central office to actuate the ringer in the phone when a call is received. This “bug” can

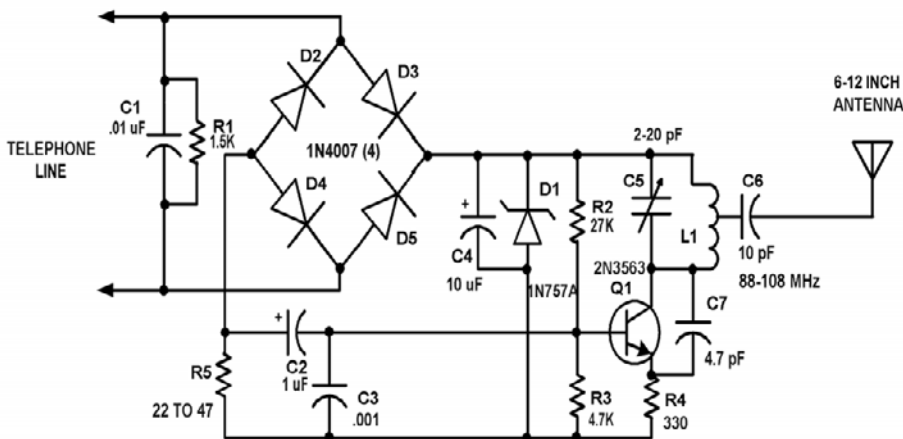

Figure 3-3
Telephone Line Bug Operating at 88-108MH

be placed in series with the hot leg of the telephone line. The DC line current may be used to derive a voltage for powering a small circuit such as the transmitter shown. R1 and a diode bridge D2 to D5 are inserted in series with the line, ensuring correct DC polarity. R1 shunts excess current around the circuit and passes 8–9 mA, about half the normal off-hook line current. C1 is an RF bypass that prevents strong RF signals accidentally picked up by the phone line from being detected in bridge D2 to D5, and thus appearing as audio on the phone line.

The voltage drop is regulated by zener diode D1 to 9.1 volts and filtered by C2. R5 is placed in series with the DC supply to sample the audio signal on the line and should be as low in value as possible. Line audio voltage drop across R5 is fed via C2 to the oscillator circuit, which is similar to that used for the wireless mike and is also tuned identically. This voltage causes frequency modulation of the oscillator operating in the 88- to 108-MHz FM broadcast band. Bridge rectifier D2 to D5 causes about a 1.3-volt drop. The total voltage drop from this circuit is 11–12 volts. This is about one-quarter of the available open circuit voltage and should not cause any problems in most instances. This “bug” can be easily detected by a knowledgeable technician because of the high off-hook circuit voltage present on the phone line. This voltage is approximately 16–22 volts, which is 11–12 volts higher than that normally encountered (5–10 volts); however, this circuit has the advantage of not having a battery that must be replaced periodically. The antenna can be a short (6-inch) wire, or the telephone line itself can be used as an antenna.

Although this “bug” will work and demonstrate basic principles, it is simple and has limitations regarding frequency stability and overall performance. Professional units designed for legal surveillance use by government and law enforcement agencies are generally very small, more complex, and built with surface-mount construction. They feature more sophisticated circuitry and crystal frequency control, and they operate on specially assigned frequencies. They also incorporate features and modulation schemes designed to make their detection more difficult.

Note that laws regulate the use of these kinds of devices, and this information is presented for educational purposes only. It is illegal to eavesdrop on private telephone lines or to use wiretapping equipment on them. The understanding of how these devices work will help in discovering illegally installed bugs on your own or others’ telephone equipment.

AM Transmitter

The final circuit discussed in this chapter is a simple AM transmitter. This transmitter is basic but allows transmission of audio to an AM radio. It consists of an RF oscillator operating in the AM broadcast band, together with a modulator stage, which mixes the incoming audio and the RF. A signal appears on the output, which has an AM component that can be picked up on a nearby AM radio receiver. In the 1950s, the vacuum tube equivalent of this transmitter was a popular project with electronics experimenters and was known as a “phono oscillator.”

One such circuit is shown in Figure 3-4. If you can find the components, and you enjoy working with old radios and antique electronics, this circuit may be of interest. It is not critical, and almost any reasonable components can be used.

For most applications, a solid-state battery-powered circuit is preferred. A simple AM transmitter of this type is illustrated in Figure 3-5. The transmitter consists of oscillator stage Q1 and modulator/buffer stage Q2. Q1 is biased via R1, R2, and R3.

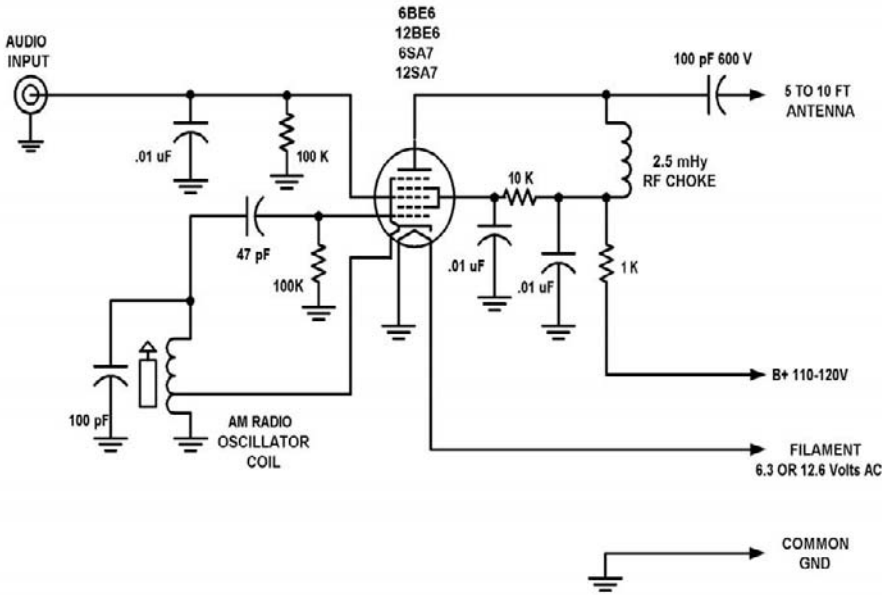

Figure 3-4
Simple Vacuum
Tube AM Radio
Transmitter also
Called Phono
Oscillator

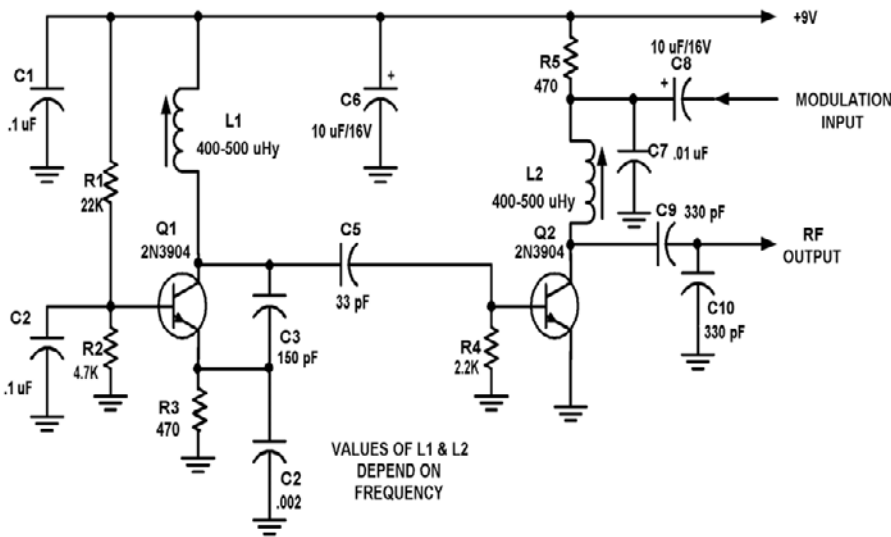

Figure 3-5
Basic Low-Power
AM Transmitter

L1, C3, and C4 form the tank circuit with feedback network C3-C4 providing feedback to the emitter of Q1. RF voltage at the junction of C3 and L1 drives buffer/modulator stage Q2. Q2 is biased by base current produced by RF rectification in the base emitter junction of Q2. C6 is an RF and AF bypass capacitor. C9, C10, and L2 form the tank circuit for the collector of Q2. RF is taken from the junction of C9 and C10 and fed to a shortwire antenna. Audio is fed to modulator Q2 via C8 and isolation resistor R5 and mixes with the RF signal in the collector circuit of Q2, producing a signal that has sum and difference frequencies if the RF carrier and AF input

Build Your Own Low-Power Transmitters: Projects for the Electronics Experimenter

(upper and lower sidebands) along with the carrier signal. An AM signal appears at the collector of Q2. Audio with an RMS voltage equal to about 0.7 times the collector voltage of Q2 is needed for full modulation of the output.

Because of the high level of audio needed, the modulation obtained from this circuit is somewhat limited with conventional audio sources because several volts of audio into a few hundred ohms is needed. The circuit demonstrates the principle of an AM transmitter, however, and with a suitable audio drive level, produces a well-modulated AM signal.

L1 and L2 are chosen to resonate with the circuit capacitances of about 150 and 165 pf, respectively, and in the test circuit, inductances of 400–500 microhenries were used to obtain the desired 600-kHz output frequency, but this circuit can be operated anywhere in the AM band with suitable inductors. For operation at 1500–1700 kHz, for example, adjustable inductors having a range of 50–100 microhenries would be suitable.

This chapter has illustrated some simple low-power transmitter circuits that can be built by experimenters in a few hours. These circuits demonstrate some of the principles used in more complex circuits and some of the limitations of simple circuits. Circuits offering a higher level of performance are discussed in the following chapters.

4. 50 mW VFO-Controlled AM Transmitter for 530-1710 kHz

The design and construction of a simple AM transmitter that can be operated in the AM broadcast band and the 160-meter amateur band for QRP (low power) experiments are discussed in this chapter. The transmitter uses five transistors and one voltage regulator IC and can be built on perfboard or in “ugly bug” style, or a PC board can be designed for it. It is a basic AM transmitter based on traditional “old technology,” and the parts should be easy to find for it. The circuit can also be built with miniature or even surface-mount components if desired, and it will run from a 9- or 12-volt battery supply.

The variable-frequency oscillator (VFO)-controlled transmitter will output 50–75 mW of RF power into a 50-ohm load, is capable of 80 percent modulation, and can be driven with line level audio. VFO control has the advantage of not requiring crystals. Crystals commit you to just one frequency and are not readily available in this frequency range in standard AM broadcast frequencies. 1.000 MHz and 1.8432 MHz crystals are sometimes available because they are commonly used in microprocessor circuitry, but this choice is fairly limited. Unless frequency synthesis is used, VFO control is advantageous in this frequency range. A frequency-synthesized AM transmitter is described elsewhere in this book but is much more complex in design than this VFO-controlled unit. For AM broadcast frequencies, VFO stability is not too difficult to obtain using standard components.

A simple audio stage can be added to boost the output of an electret or dynamic microphone to a sufficient level (1 volt peak-to-peak) if desired, but this step was not done on this design. A schematic of a typical audio amplifier for this use is shown in Figure 4-1. It consists of a low-noise transistor and bias and coupling capacitors. One precaution must be taken with transmitters in general. It is possible for the transmitter

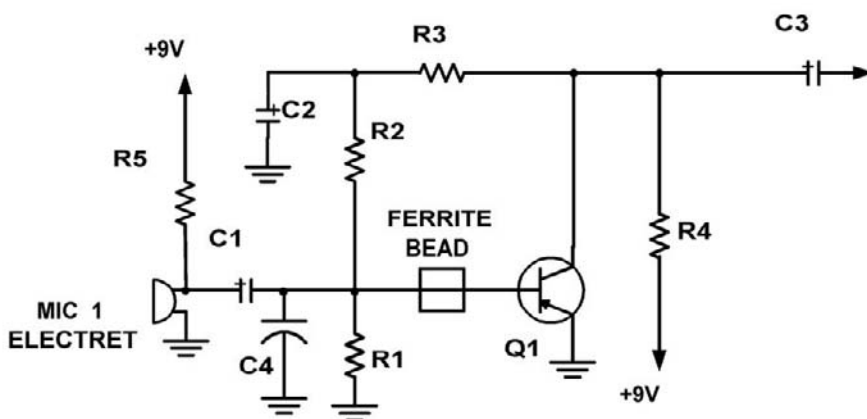

Figure 4-1
Audio Preamplifier Circuit

Build Your Own Low-Power Transmitters: Projects for the Electronics Experimenter

signal to be picked up by the microphone or audio input device, and this RF signal can be strong enough to be detected in the base-emitter junction of the first audio stage. This problem is especially noticeable in AM transmitters and can cause a feedback howl or squeal. It also can occur with SSB transmitters, and in TV transmitters, it may show up as severe buzzing in the audio. FM transmitters are not as bad in this respect, but the stray RF pickup can upset the bias in the first audio amplifier, causing possible audio distortion. The cure for this problem is to RF bypass the audio input and/or place a series RF choke or high resistance in series with the base lead of the first audio stage. In the microphone amplifier circuit shown, C4 serves this function. C4 can be typically 470 pf to as much as .01 uf. Chip capacitors are effective and are preferred for their lower inductance. Ferrite beads placed on the base lead of the audio transistor act as RF chokes and work well in some cases. Every case is different, though, and some experimentation may be needed to find the best solution for each circuit.

The schematic of the AM transmitter is shown in Figure 4-2. Q1 is a series-tuned Colpitts oscillator circuit. This circuit features relatively high-frequency stability compared to most other oscillator circuits. The stability arises from the fact that the active device is loosely coupled to the oscillator frequency-determining circuit. The frequency is determined by C1 and C2, L1, and to a very small degree, C4 and C5. Ideally, these components should be low-loss, high-stability components, but we used an ordinary NPO ceramic at C2, a polyethylene trimmer for C1, and mylar capacitors for C4 and C5. A low Q RF choke was used for L1 for small size, although a high-Q air wound or a stable ferrite toroidal inductor would be traditionally used in this spot. After construction, however, excellent stability with time and applied voltage was observed, the circuit drifting less than 500 Hz over 24 hours in a room-temperature environment. This result is more than adequate for AM use and in a simple hobby application such as this one.

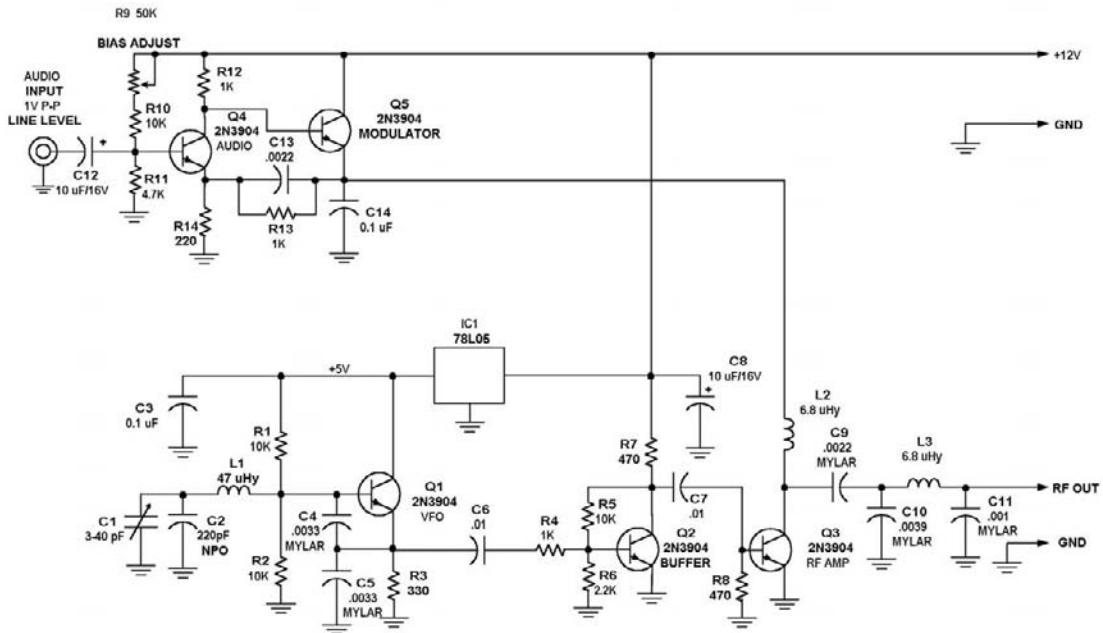

Figure 4-2
Schematic of 5mW AM Transmitter Operating at 1650kHz

By proper choice of components and suitable mechanical construction, this project could be improved by an order of magnitude. Considering that the transmitter was constructed on a 2-by-3-inch piece of perfboard using off-the-shelf components, it is not doing badly at all. R1, R2, and R3 bias Q1 and IC1 supplies a regulated 5 volts, aiding stability. RF output is taken from the emitter of Q1 and fed to buffer stage Q2, which acts as a rudimentary op amp, and the “virtual ground” seen at the base of Q2 acts to minimize changes in loading on the RF oscillator circuit. Q2 has a voltage gain of about 10, determined by R4 and R5. Q2 drives the base of RF amplifier Q3 via C7 and self-bias resistor R8. Q3 operates in class C and delivers about 50–75 mW RF output. L2, C9, C10, L3, and C11 act as a matching and filtering network optimized for 1650 kHz.

If operation on other frequencies is desired, the L and C values can be scaled appropriately in both the Q1 and Q3 circuits. Operation at the high end of the AM band was chosen for two reasons: (1) there are fewer stations in the newly allocated 1600- to 1700-kHz portion of the band, and (2) the radiating antennas are likely to be more efficient, and better range can be expected. A 10-foot antenna and 100 mW is allowed by the FCC for Part 15 operation, however, the circuit can be operated anywhere between 150 and 2000 kHz with the appropriate components in the RF circuits. This covers the entire long- and medium-wave broadcast bands, and the 160-meter amateur band, on which some AM activity takes place.

Modulation is obtained by modulating the collector supply for Q3 with the input audio. Q4 and Q5 are a feedback pair consisting of an NPN-PNP direct-coupled audio amplifier. C14 is an RF bypass capacitor, and R13, R14, and C13 make up the feedback network. A gain of around six is set because this allows full modulation with a 1- to 2-volt p-p audio signal. R12 provides bias for Q4 collector and Q5 base. The collector of Q5 has as its load the collector circuit of RF amplifier Q3. R8 and R11 bias Q4, and the exact Q point is set with R9. R9 is adjusted for symmetrical modulation and is typically set so there are 5–6 volts at the collector of Q5, assuming a 12-volt supply. Good modulation up to about 80–85 percent can be obtained with this circuit. Input audio is coupled to the base of Q4 via C12. The frequency response is 3 dB at 7000 Hz, which is adequate for most AM audio work, but this level can be changed by changing C13 as required. C8 serves as a bypass capacitor for the 12-volt supply line. With appropriate adjustment of R9, the circuit can also be operated from a 9-volt supply with slightly less (30–50 mW) RF output.

The transmitter can be built in almost any reasonable mechanical configuration to suit your needs. Because the frequencies are relatively low, layout is not too critical, but it is wise to keep outputs away from inputs. A layout in which the components are arranged similarly to how the schematic is drawn is a good idea if you can arrange it. The circuit should easily fit on a 2-by-3-inch (5-by-7.5-cm) piece of perfboard. The thickness is limited by component height, but 1/2 inch (1.25 cm) should be attainable. It can be enclosed in a plastic experimenters’ project box, but a metal case is a good idea because it provides RF shielding and protects the VFO components from detuning, with resulting unwanted frequency shifts. RCA phono connectors are fine for audio and RF at AM frequencies, and the power connector can be anything you wish to use.

One common application of transmitters of this type is in “talking signs.” A transmitter such as this is set up with an 8- or 10-foot antenna and fed a message from a tape deck or a solid-state audio recorder chip. The message continuously repeats, and a sign is placed in an appropriate location telling people where to tune their AM radios to hear the message. Real estate brokers, for example, set up a transmitter in a house for sale, and a sign is placed outside the house announcing the details. Prospective buyers can tune their car radios to the indicated frequency to hear the details. This is commonly called a “talking house.”

Build Your Own Low-Power Transmitters: Projects for the Electronics Experimenter

Another application is in surveillance, or monitoring sounds in a room. This transmitter can legally be connected to a transmitting antenna and used by licensed amateurs as a low-power AM transmitter, for experimental work or just for fun, to see how far the signal can be heard. Ranges of 10 miles or more on 160 meters (1800–2000 kHz) can be obtained with this transmitter if good antennas are used. This phase of ham radio is known as QRP operating. QRP stands for low power, and originally QRP was used as a signal to signify “shall I decrease power?” by radio operators in the early days of radio. This signal is one of a whole series of abbreviations known as “Q” signals that were invented for brevity and to standardize messages and are still used today by hams who prefer CW (Morse code) operation. Today, QRP is a popular mode of ham radio operation, and thousands of miles are often covered by low-power transmitters operating at 1 watt or less.

Range solely depends on the antenna used. For most applications, a length of wire 3–10 feet is sufficient, but do not exceed 10 feet. A good earth ground connected to the negative side of the power supply will help. Range with this length of wire is 50–200 feet, and more if some effort is made in the area of antenna matching.

Parts List

Resistors (1/8 watt or larger, 10 percent tolerance)

R1, R2, R5, R10	10K
R3	330 ohms
R4, R12, R13	1K
R6	2.2K
R7, R8	470 ohms
R9	50K pot, linear taper
R11	4.7K
R14	220 ohms

Capacitors (*values for 1650 kHz shown)

C1	3–40 pf trimmer *
C2	220 pf NPO or silver mica*
C3, C14	.1 mfd mylar
C4, C5	.0033 mfd mylar or silver mica
C6, C7	.01 disc ceramic
C8, C12	10 ufd 16 volt electrolytic
C9, C13	2200 pf mylar or silver mica*
C10	3900 pf mylar or silver mica*
C11	1000 pf mylar or silver mica*

RF inductors (values for 1650 kHz shown)

L1	47 microhenry
L2,L3	6.8 microhenry

Transistors and ICs

Q1 through Q4	2N3904 or ECG123
Q5	2N3906 or ECG153
IC1	78L05 5V regulator

Also, hardware as needed, perfboard or PC board to suit a 9- to 12-volt battery pack, connectors and jacks as needed, and case as required.

5. PLL Synthesized AM Transmitter for 530-1710 kHz

The AM88 is a low-power (100 mW) AM transmitter for use under Part 15 FCC regulations for low-power unlicensed applications, such as hobby, short-range AM broadcasting, carrier current radio, and experimental use. Old timers may remember the “phono oscillators” popular as construction projects back in the 1950s, using vacuum tubes such as the 12BE6 and 12SA7. These were pentagrid (5 grids) tubes that acted as an oscillator and modulator in this application. They operated in the AM broadcast band and were used as hobby AM broadcast stations and for playing records (remember them?) through the AM radio. FM was not as common then, and stereo had not yet been available in the form of radio broadcasts. These phono oscillators typically ran the tubes at around 120–150 volts at 3–5 ma plate current (360–750 mW power input), used a length of wire as an antenna, and had free-running LC oscillators. Although they worked well, they were really just toys used mainly as wireless microphones and for experimentation.

This chapter describes a modern version of the old phono oscillator. This AM88 AM transmitter has features that would have been science fiction in 1950. It is crystal stabilized, covers a 10 to 1 frequency range, runs off a 12-volt supply, and has high-level AM modulation. The AM88 is phase locked loop (PLL) synthesized and crystal controlled for frequency stability and easy compatibility with both analog and digitally tuned receivers. The PLL synthesizer has a resolution of 1 kHz. The AM88 has a wide frequency range and may be operated anywhere (1-kHz steps) between 100 and 2000 kHz (150 kHz to 1710 kHz for best results). This range includes standard AM medium-wave broadcast (530–1710 kHz) and the long-wave AM broadcast band (150–285 kHz) used in Europe and Asia. Resolution of the PLL supports 10-kHz or 9-kHz channel spacing used in various areas of the world. Carrier-current operation is possible using the lower frequencies (generally less than 500 kHz). This allows signal distribution over AC power lines. Although the transmitter is basically AM, continuous wave (CW) operation (for Part 15 experimental 160–190 kHz license-free operation) is possible. FM operation is also possible for carrier-current applications by means of a simple PC board switch setting. The transmitter is designed for 100 mW, but RF output can be increased up to 1 watt for these applications.

Although the FM band is popular for applications such as this one, as well as for supporting stereo audio, for some applications the AM band might be better. Range can be better because higher field strengths are allowed. At 600 kHz, up to 400 uv/meter is allowed at 10 feet. Receiver bandwidths are narrower, and AM is superior to FM under weak-signal conditions (below threshold). The AM band generally has more usable channels than the FM band, especially during daylight hours. Construction is less critical because frequencies are low, and only simple test equipment is needed to set up an AM transmitter. For some applications, such as the “talking house,” whereby real estate brokers use small transmitters planted in houses so the

Build Your Own Low-Power Transmitters: Projects for the Electronics Experimenter

prospective buyers can hear the sales pitch on the car radio, AM may be more useful because almost every car has an AM radio, but it may not have FM. (FM reception is still poor or limited in many areas in parts of the world.) A simple AM transmitter is also an excellent learning tool for beginners, who might find the very high frequencies and the added complexities of FM stereo a bit daunting as a first-time learning experience.

The AM88 uses four integrated circuit (IC) devices and nine transistors to implement a complete PLL-synthesized AM transmitter. The transmitter can be broken up into several subsystems: the audio amplifier, AM modulator, PLL frequency synthesizer, and RF output amplifier and filters. See the block diagram (Figure 5-1) and the schematic (Figure 5-2) for reference.

The audio section is made up of IC3a and IC3b, a dual op-amp LM1458N, and AM modulator Q6 and Q7. Line-level audio inputs of approximately 0.2–1.0 volt RMS (high impedance approximately 10K) connected to J1 is fed to a gain-controlled R1 and a diode-controlled attenuator D1, D2, and R1. The diodes act as variable resistances to small signals (50 mv or less). This is done to provide a means for automatic gain control of the audio section. Coupling capacitors C3 and C1 pass these signals to an audio amplifier op-amp circuit consisting of R3 and R4, and operational amplifier IC3a, with associated components R5, R6, C3, and C2. C2 limits frequency response to 10 kHz. R5, R6, and C3 provide a bias of half the supply voltage for the op amp, eliminating the need for a negative supply. The audio gain of this stage is nominally 20 times (26 dB), assuming that D1 and D2 are not conducting. The audio from this stage is coupled to R7 and blocking capacitor C5 and to DIP switch S2A and S2B. This switch is used to route audio to either the AM modulator for normal AM operation or to the PLL circuit for FM. FM may seem an oddity at normal AM frequencies; this subject is discussed later.

The AM modulator consists of Q6 and Q7. The circuit is configured as a shunt feedback pair, and the bias point is set via R14, R15, and pot R16. The emitter of Q7 has a DC plus audio component and is used as a source of modulated DC for the RF output stage. The voltage at the emitter of Q7 sits around +5.0 DC volts. With audio

Figure 5-1
Block Diagram of
the AM88 Low-
Power AM Trans-
mitter

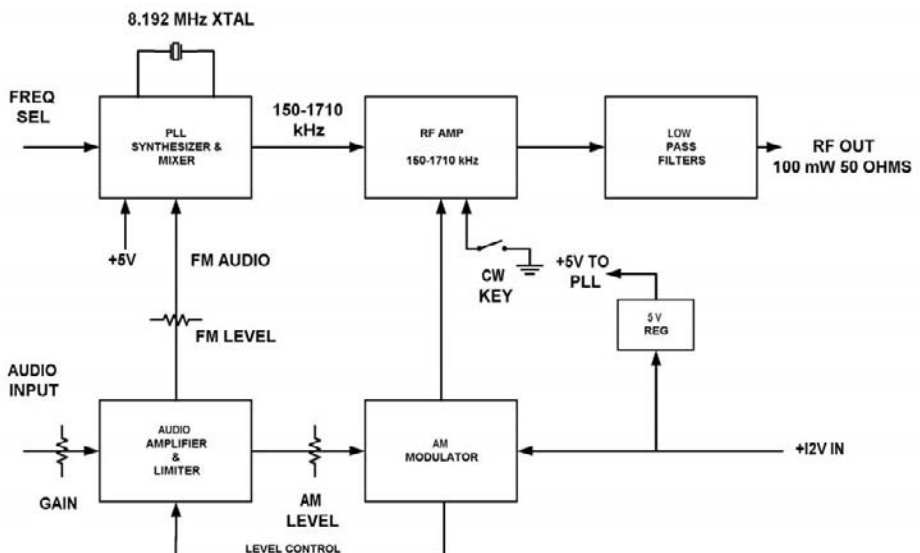

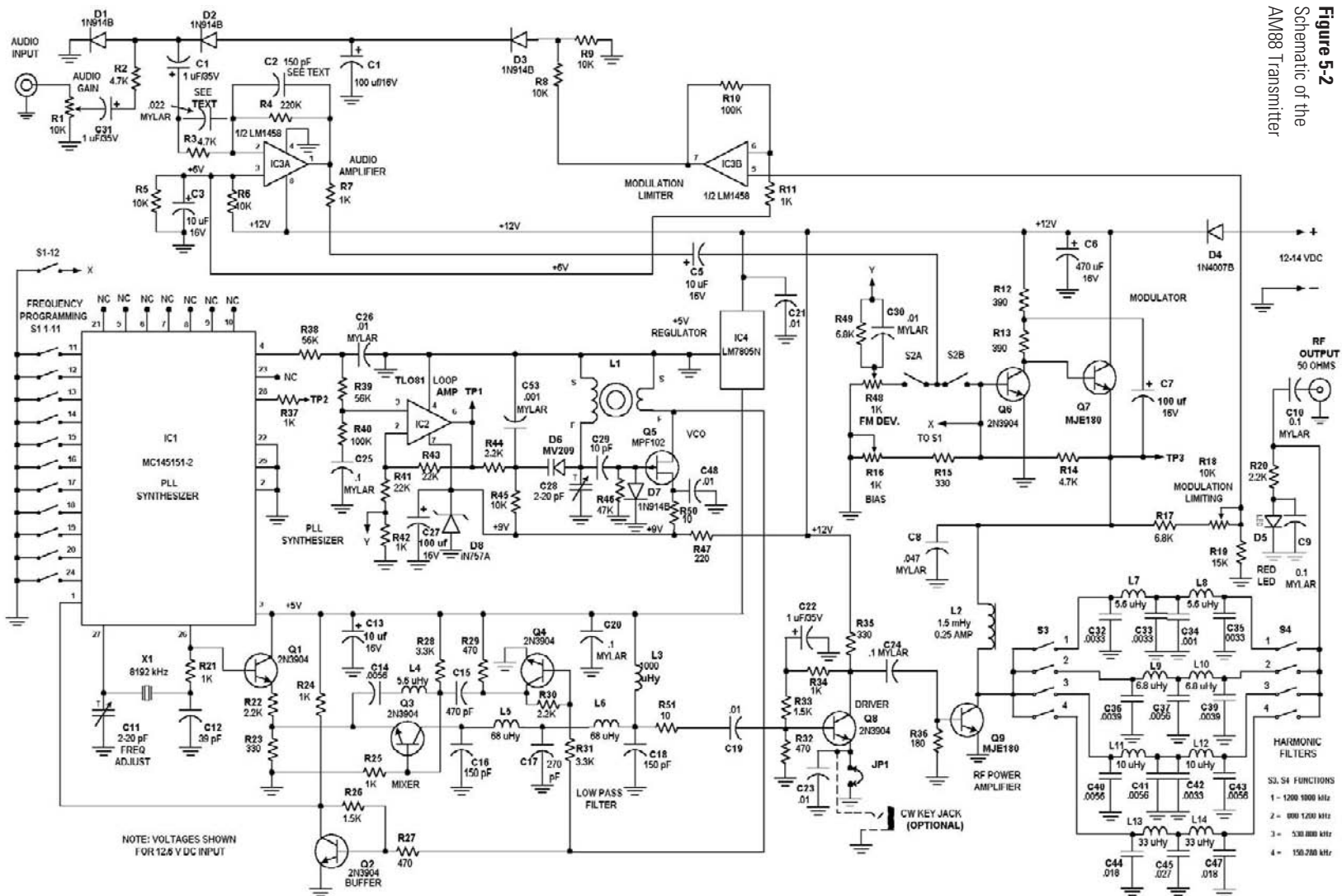

Figure 5-2
Schematic of the
AM88 Transmitter

drive from S2B, this voltage swings between less than 1 volt and to within 1 volt of the full supply voltage. Base drive resistors R12 and R13 form a split resistance to allow capacitive coupling of the modulator audio component to the junction of R12 and R13. Because the voltage across a capacitor cannot change instantly, a sufficiently large capacitor acts as a battery. This has the effect of maintaining a constant voltage across R13 and hence a constant drive current. This allows the base of Q6 to swing above the supply voltage by about 0.7 volt, ensuring that the emitter of Q7 can reach almost the full supply voltage. This technique, which is widely used in audio power amplifiers, is called *bootstrapping*. Because the RF output of the RF stage is proportional to the supply voltage, this technique allows full AM modulation of the RF output voltage to be achieved. The bias point is set to achieve symmetrical modulation with R16.

If the audio peak voltage was not limited, severe distortion would result from clipping of the RF output peaks and cutoff of RF output on negative peaks. This is called *overmodulation*. To prevent this problem, a sample of the modulator output is taken through resistive divider R17, potentiometer R18, and R19. This voltage is compared with the op-amp reference voltage in comparator IC3B, and if it exceeds the bias level (half the supply voltage), then IC3 pin 7, which is normally at +2 volts, goes more positive. This is applied to resistors R9, R10, forward-biasing D3, and charging C4. C4 is an audio bypass capacitor that prevents audio components from feeding back through the automatic gain control (AGC) network; C4 also determines the time constant for the AGC network. The DC bias developed across C4, if more than about 1.2 volts, forward biases D1 and D2, causing their dynamic impedance to drop sharply from nearly infinite down to as low as less than 100 ohms. This reaction causes the audio input present at the junction of R2, C1, D1, and D2 to be attenuated, reducing the modulation level. In practice, R18 is adjusted so that this occurs at 85–90 percent modulation. Although this scheme does not prevent negative clipping or deliberate overmodulation, it works well for normal application with speech or music.

The PLL synthesizer section uses an MC145151-2 LSI chip. This chip contains a reference oscillator, reference divider, charge pump phase detector, and variable divider that can be programmed for divide ratios of 3 to 16383. The reference divider is programmable, by hardwiring pins, at various fixed ratios that are mostly powers of two. In this application, it is set up to divide by 8192 so that a standard 8.192-MHz crystal will provide a reference frequency of 1 kHz. This sets the resolution of the synthesizer. The maximum input frequency that this chip can directly handle is approximately 12 MHz worst case. The AM broadcast band 530–1710 kHz has channels at 10-kHz spacing in the United States and Canada (this includes the newly expanded U.S. 1600–1710 kHz section) and most areas in the Americas. In other parts of the world, channels with 9-kHz spacing are used. Additionally, in Europe and parts of Asia, the long-wave band is used, with frequencies between 150 and 285 kHz, also at 9-kHz channel spacing. The synthesizer covers all of these frequencies, but in the interest of optimum synthesizer performance and considering cost limitations and circuit simplicity, the tuning range has been restricted to 2 MHz. The synthesizer supports all channels between 150 and 1710 kHz in 1-kHz increments. Frequencies from as low as 50 kHz and as high as 2047 kHz can be generated, but the circuit component values—mainly in the filters and RF chokes—are not optimum at these extremes.

In order to cover these extremes, some changes in values of these components are necessary, which is beyond the scope of this discussion. In order to eliminate a noisy microprocessor and display, the frequency desired is set by using an onboard 12-section

DIP switch S1. Eleven sections are used for programming, and the twelfth for something else. A binary code is used, the desired transmitter frequency is determined, and its binary equivalent is set using the DIP switches. Normally, once a clear channel is found or determined, the transmitter is set here and left alone. In most populated areas, relatively few clear channels are available, and especially at night when distant stations can be heard, a good, clear channel can be hard to find. In some areas they are rare, so, unlike a receiver, there is little need to reset the frequency often. Additionally, most low-power AM units such as this one operate between 1600–1710 kHz or 525–535 kHz. Antenna efficiency is best at higher frequencies because any legal antenna used for U.S. FCC Part 15 applications is a very small fraction of a full-quarter or half-wave radiator. Therefore, a microprocessor and display would be overkill in this application.

Although direct generation of 150–1710 kHz frequencies can be achieved with the synthesizer, this is more than an 11:1 frequency ratio. A single-loop synthesizer will necessarily need a voltage-controlled oscillator (VCO) with this wide range, and the divide ratio needed in the variable divider will vary from 150 to 1710. It is difficult to control synthesizer loop performance to get reasonable behavior (settling time and damping ratio) over such a wide range; however, there is an easier way. The synthesizer chip IC1, a Motorola MC145151-2, has a programmable reference divider. If a standard 8.192-kHz microprocessor crystal is used, the reference divider may be programmed to divide by 8192. This will yield the desired 1-kHz reference frequency needed for 1-kHz frequency resolution. Because the chip can be programmed to divide by up to 16383, in binary, the variable divider section of the chip can be set up to divide by 8192 by permanently tying its most significant digit high. Then, by grounding the next two significant bits low, and using the remaining 11 bits in conjunction with a DIP switch, the divider can be made to divide by 8192 to 10239. This allows a frequency range of 8.192 to 10.239 MHz to be generated by the PLL synthesizer.

If we take this frequency range and mix it with the 8192-kHz reference oscillator signal using a mixer circuit, and a low-pass filter on its output, we end up with an output of theoretically DC to 2047 kHz. The DIP switch has to produce a binary code that is the binary equivalent of the output frequency. This task is simple, cheap, and allows a synthesizer loop design that has only a 1.25:1 range, which is easily done. The chip will directly handle these frequencies with no prescaler needed. Of course, a mixer and filter is needed, but this device is simple and straightforward and does not require any loop design compromises. Practically, because of the need for filters, coupling capacitors, and RF chokes in the transmitter, we use only the 150–1710 kHz portion of the possible output frequency range, but this is not absolutely necessary, and with suitable components, the full range could be used if desired.

The circuit of the PLL synthesizer operates as follows: Q5, an MPF102 FET, is configured as an oscillator whose frequency is determined by L1 and the capacity of varactor diode D6, trimmer C28, and the circuit stray and FET input capacitance. This oscillator operates in the 8.2–10.2 MHz range. R46 provides DC bias for Q5. C53 RF grounds the anode of D6, which is fed a variable DC bias from R44 and R45. Depending on this DC bias and the setting of C28, this will be anywhere from 8.2–10.2 MHz. Oscillator signal is taken from the source of Q5. Part of this signal is passed to amplifier stages Q2 and Q4. R27 feeds signal to Q2, which is connected as a wideband feedback stage with R24 and R26 for feedback and bias. A signal large enough to drive the input of the variable divider section of IC1 (pin 11) appears at the collector of Q2. The divider is programmable via S1 to divide between 8192 and 10239, which is equal to the desired output frequency plus 8192.

For example, if a frequency of 1600 kHz is desired, then the divide ratio will be programmed as 1600 via the setting of S1. The internal variable divider will produce a signal to be fed to the phase detector at the transmitter frequency divided by 1600 because we have a division of 1600 times from the programmable divider. Meanwhile, the phase detector is fed a 1-kHz reference signal derived from an internal reference oscillator and divider, which uses external components R21, C12, X1 (8192-kHz crystal), and trimmer C11. These parts determine the oscillator frequency. C11 is used to set the frequency exactly to 8192 kHz. An internal divider divides this by 8192 and produces the 1-kHz reference. The output frequency accuracy depends on having an exact 1.000 kHz, which in turn needs an exact 8192-kHz crystal oscillator frequency. The phase detector generates a voltage, which depends on the relative phase difference between the reference and variable divider output waveforms.

For example, suppose the divider output starts to lag the reference. This implies that the divider, and hence the VCO frequency, is tending to go lower. In this case, the phase detector produces positive-going pulses and feeds these to the sample and hold network R38, C26, R39, R40, and C25. C25 is charged to a higher DC voltage. IC2, a CA3420 CMOS op-amp, acts as a buffer amplifier for the PLL phase detector and provides a very high impedance for the sample and hold circuit, minimizing 1-kHz reference frequency sidebands and allowing smaller capacitors to be used in the compensation network. It also provides an easy method for injection of audio signals into the VCO for directly modulating the carrier frequency.

The high-impedance CMOS amplifier consisting of IC2, R41, R42, and R43 produces a positive-going output, which is fed to D6 via R44 and R45, causing the oscillator frequency to increase. The opposite happens if the VCO drifts higher, causing the divider output to lead the reference. Then D6 is biased with a negative-going change in DC bias and causes the VCO to lower its frequency. In this way, the VCO frequency is locked to the reference frequency and will not drift. It will be exactly equal, in kHz, to the programmed divide ratio plus 8192. In our case, we have programmed 1600 so that the output frequency will be $1600 + 8192$, or 9792 kHz. Next, this frequency must have 8192 kHz subtracted from it to yield the final desired 1600 kHz output.

The final output frequency is obtained by mixing the PLL output 8192 to 10239 kHz (nominal) frequency with the 8192-kHz reference oscillator in a mixer circuit. A sample of the 8192-kHz oscillator is tapped off IC1 via emitter-follower Q2 and divider R22 and R23. This signal is fed to the emitter of mixer stage Q3. Q3 is biased by R28, R25, and R28. L4 and C4 provide a low-impedance path for the desired difference frequency output. A sample of the VCO frequency is fed to buffer Q4 through R31 and is coupled to the base of mixer-transistor Q3 via C15. The input frequencies and their sum and difference frequencies appear at the collector of Q3. The collector feeds low-pass filter (LPF) C16, L56, C17, L6, and C18. Only the difference frequency passes, the rest being rejected. DC bias is fed to Q3 via RF choke L3. R50 and C19 couple the difference frequency component to output amplifier stages Q8 and Q9.

The transmitter RF output signal that is to be modulated is produced by amplifying the mixer output from the LPF in Q8. Q8 is a conventional common emitter stage, with DC feedback biasing via R32, R33, and R34. C22 prevents AC feedback and preserves stage gain. R35 is a load resistor for Q8, and C24 couples signal-to-output amplifier stage Q9. R36 is a bias resistor, and Q9 is fed modulated collector supply voltage of around 5 volts from the emitter of Q7. The emitter of Q8 is connected to ground via a jumper, which can be opened in order to insert a key or keying circuit for

CW (Morse code), commonly used in the 160–190 kHz Part 15 experimenters' band (also known as the 1750-meter band). C23 provides RF bypassing in this application. Q9 was chosen to withstand operation into an open circuited load and to deliver up to 1 watt CW power at the lower frequencies (Part 15 160–190 kHz operation) or for carrier-current applications. It will deliver a 100-mW carrier at the higher frequencies (1600–1710 kHz), which requires 400 mW PEP output at full AM (100 percent) modulation.

In this stage, the signal is amplified to the final output level and then fed to a set of harmonic filters L7–L14 and C32–C47. The filters are low-pass, five-element Tschebychev types and should be designed to attenuate the second harmonic of the signal by at least 20–30 dB or better. A filter is useful only over about 65–90 percent of its cutoff frequency, so that the second harmonic is well into the stop band of the filter. Hence, four filters are provided on the PC board, to cover the AM broadcast band and the 150–280 kHz range. S3 and S4 are DIP switches used for filter selection. Only one filter is used at a time. R20, bypass C9, and LED D5 are used as an output indicator, and LED D5 will not light if the switches S3 and S4 are inadvertently set to different filters. The LED will flicker slightly when modulation is present, therefore serving as a rudimentary modulation indicator. The filters shown are for 1200–1750 kHz, 800–1200 kHz, 530–800 kHz, and 160–280 kHz operation. They may be changed by scaling the inductors and capacitor values inversely in proportion to the frequency ranges desired. RF output from the transmitter should be fed into a load of 50 ohms.

IC4, a 5-volt regulator, supplies 5-volt DC to IC1, the VCO, and the mixer circuits. Bypasses C20 and C21 ensure regulator stability. Capacitor C6 and diode D4 provide filtering and reverse-polarity protection of the 12-volt DC input, which may be from 11–16 volts in actual use. Excess of this voltage may cause damage, and less than 10 volts may produce poor results. Optimum power is 12–13.2 volts. Excessive noise on the DC supply line may cause this noise to be heard on the transmitted signal as interference and hum. It is normal for Q7 to get warm in operation, and if you prefer (not needed), a small clip on heatsink can be placed on Q7 to cool it.

The FM mode is useful for the low-frequency carrier-current operation that this transmitter is capable of. With a PLL, very little circuitry is necessary for FM, and this mode is obtained practically for free. Deviation up to 75 kHz is easily obtained, allowing much quieter carrier-current operation than AM can provide at the low frequencies used in carrier-current work. Typically, frequencies in the 100–300 kHz are used, but power line noise can be severe at these frequencies. Frequency modulation is accomplished by injecting audio from the audio amplifier IC3a into IC2. Instead of being returned to ground, R41 is fed from a preemphasis network R42, R49, and C30. This gives a preemphasis compatible with standard FM broadcast practice. Potentiometer R48 sets the deviation. The audio across R42 is fed to IC2, and IC2 has unity gain for this audio. Therefore, an audio voltage is superimposed on the voltage to varactor D6.

Because the bandwidth of the synthesizer loop is less than 20 Hz, the relatively high audio frequencies are not “corrected out,” and as long as no DC component is injected (assuming symmetrical FM, which is the usual case), the variations in frequency undermodulation are averaged out. The resultant modulation is clean and low in distortion because the VCO has a dynamic range of several volts, and a 1-volt change produces about 300-kHz frequency variation. Therefore, only about 250 mV peak audio (about 176 mV RMS) is needed for full modulation. This means about the same audio needed for 100 percent AM at the input to the transmitter will also be sufficient for the FM mode, assuming that R49 is set to about 80 percent of maximum.

Build Your Own Low-Power Transmitters: Projects for the Electronics Experimenter

The VCO is highly linear over such a small range, ensuring good-quality FM audio. Note that section 12 of the programming switch S1 should be closed to disable the AM modulator and obtain full RF power in this mode; S2A must be closed; and S2B must be open to route the audio to the FM modulator circuitry.

As with any device coupled to the AC power line, RF should be fed into a suitable isolation network with components rated for the job. This means capacitors AC voltage rated at least twice the peak line voltage, and any coupling transformers used should withstand 1500 volts and preferably more. The transmitter wants to see a 50-ohm load, and suitable matching circuits and padding resistors are needed because most power lines have RF impedances less than this amount (see Figure 5-3).

The AM88 needs an antenna. For many applications, a 56-ohm resistor shunted with a simple whip antenna as a radiator is adequate. The whip antenna should be only as long as needed, *no more than 10 feet* (3 meters), to avoid violating Part 15 FCC rules. (This issue is discussed later in the Appendix.)

A PC layout is shown in Figures 5-4 and 5-5. Note that grounded leads of resistors are to be soldered on both sides of the board. This step is essential for good grounding. All parts are mounted tight and close to the board, except chokes. This is important for reducing audio noise pickup and for proper operation of the synthesizer and RF circuits. It also gives a professional appearance to the finished board. Begin construction by inserting all resistors in the PC board (see Figure 5-4). Next solder all top ground connections. Install all diodes, carefully observing polarity. Next, install all capacitors. Make sure to observe the polarity of all electrolytic capacitors. Next, install the transistors. Be careful with Q7 and Q9 because these have an E-C-B pinout when viewed from the front side. Install trimmer C11, C28, and potentiometers R1, R16, R18, and R48. Preset C11 to 75 percent capacitance (plates 3/4 meshed). Preset C28 to halfway. The AM88 will operate well enough for setup with these initial settings. Install crystal X1, DIP switches S1, S2, S3, and S4, and the ICs, being *extremely careful* about correct orientation. If you wish to use low-profile DIP sockets, this is permissible.

Carefully check all work done so far for accuracy and orientation. Solder all bottom connections made so far. Carefully fabricate coil L1 and install it in the PC board. The toroidal core is wound with #24 enamelled wire (see Figure 5-6). Make sure to connect the leads as shown, or the VCO will not operate. Use the toroid coil-winding diagram as a guide. Leave an extra 1–2 inches of lead length on the lead of the 14-turn winding connected to C28, C29, and D6. An extra turn has been deliberately added on the primary winding to allow adjustment of inductance during setup.

Figure 5-3
Power Line Coupler for Carrier Current Applications of the AM88

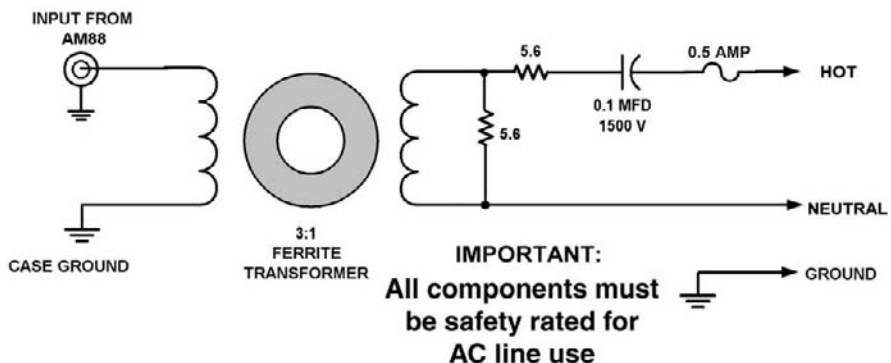

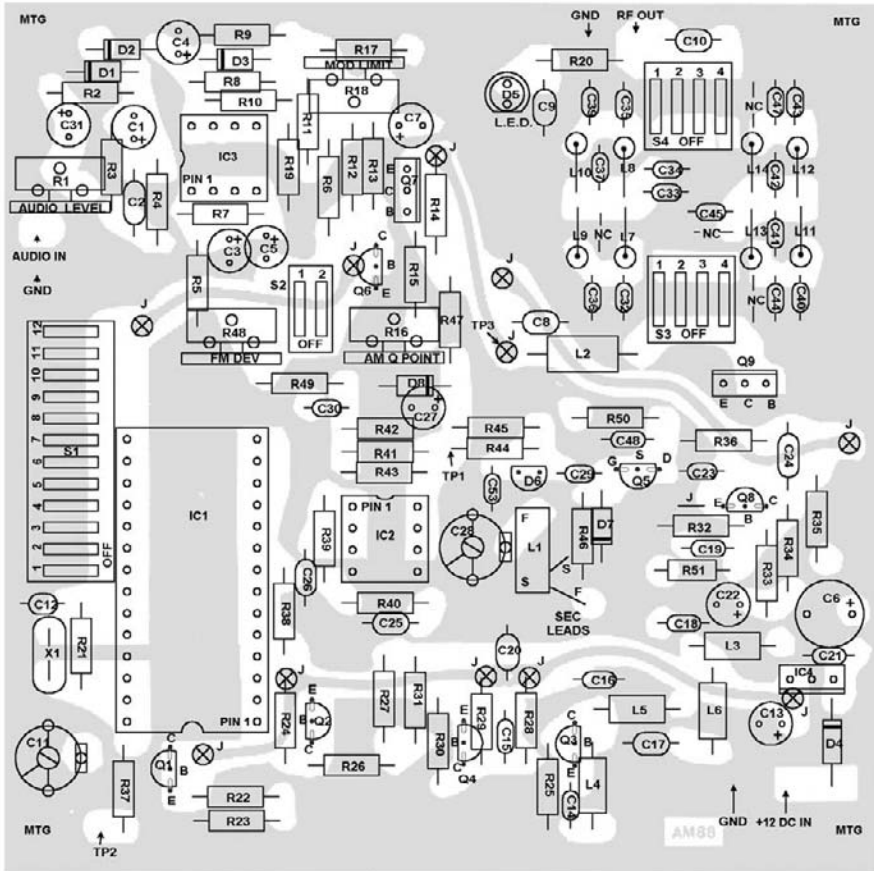

Figure 5-4
Parts Layout of the
AM88 Transmitter
PC board—Component
Side

Install RF choke L2, being careful not to bend the leads sharply too close to the choke body because this may damage the choke. Install L3, L4, L5, and L6 in the same manner. Next, install the remaining inductors as shown, standing them on end and bending the top lead down to fit the PC board (see Figure 5-6). Again, carefully inspect all work so far. Look for solder shorts, poor joints, missing parts, incorrect parts placement, and so forth. You are ready to check out the board once everything is satisfactory.

To set up the AM88, you will need the following items:

- DVM or analog VOM, 20 K/volt or better
- Power supply 12–13.2 volts DC (9 AA or C or D cells in series is acceptable)
- AM broadcast or communications receiver
- CD player, tape deck, or other line-level audio source
- Patch cable for audio connections
- Test leads as necessary

The setup procedure is as follows:

1. Carefully inspect the PC board for shorts, missing or wrong parts, IC and transistor orientation, polarity of diodes and electrolytics, and any assembly mistakes, such as missing or poor solder connections. Make sure that the top

Figure 5-5
Component and
Solder Side View
of the AM88 PC
Board

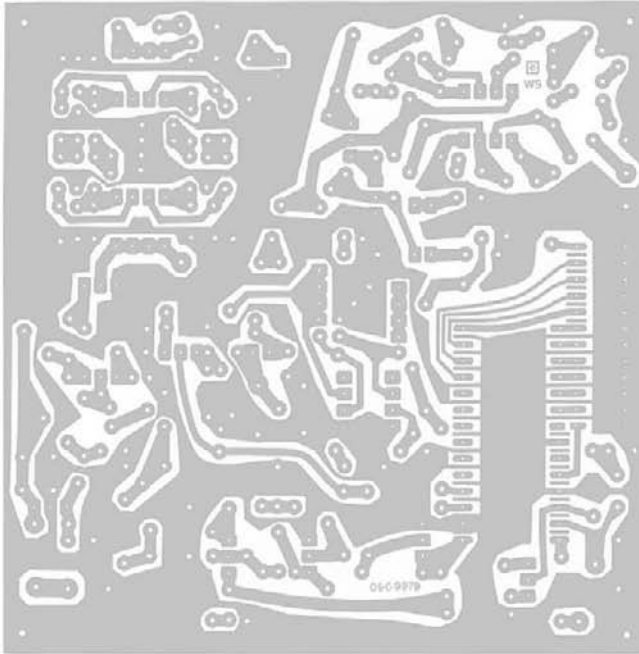

SOLDER SIDE

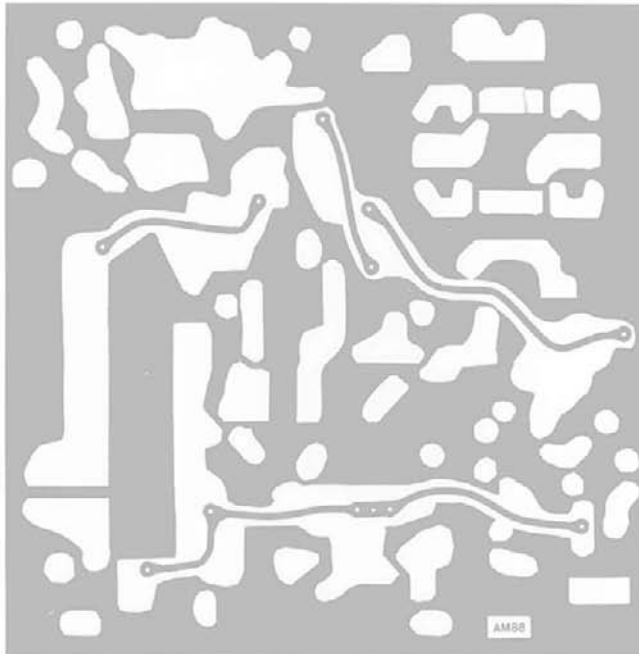

**COMPONENT
SIDE**

traces supplying +12 volts to the audio section and +5 volts to the synthesizer circuitry are soldered to the component leads, passing through them, and that jumpers (J) between top and bottom traces are installed where necessary as indicated in Figure 5-4.

AM88 WINDING DETAIL FOR L1

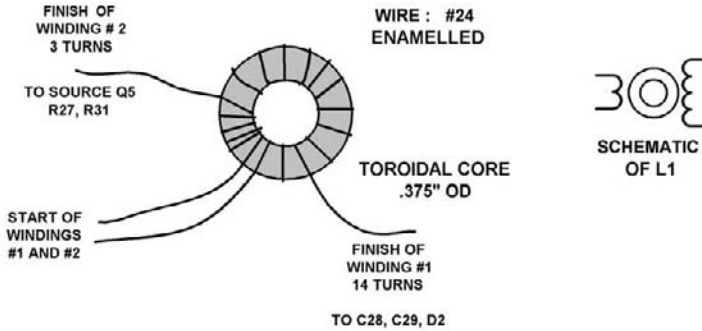
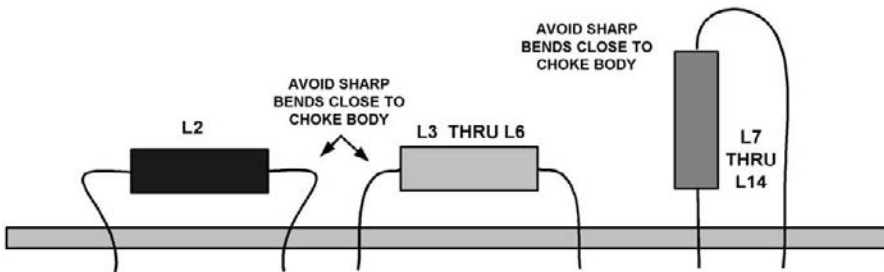

Figure 5-6
Winding and Mounting Details for L1 and L2 Through L14 of AM88 Coils

METHOD OF MOUNTING RF CHOKES L2 THRU L14



2. Preset the following switches and controls:

S1: Positions 1 through 12 all "off"

S2: Position 1 (S2A) "off"

S2: Position 2 (S2B) "on"

S3, S4: Position 1 "on"

S3, S4: Positions 2, 3, 4 "off"

R1: 25% of full clockwise rotation

R16: 25%

R18: 75%

R49: 75%

C11: 50% full plates half meshed

C28: 100% plates completely meshed

3. Connect a 56-ohm 1/4-watt resistor between RF output and ground.

4. Connect the 12-volt power supply to D1 and ground; the negative lead of supply to ground; and positive to D1. Observe the current drawn; it should be about 50–200 ma. If it is appreciably less (less than 50 ma) or more (more

Build Your Own Low-Power Transmitters: Projects for the Electronics Experimenter

Figure 5-7

The AM88 PLL Synthesized Low-Power AM Transmitter in a Metal Case

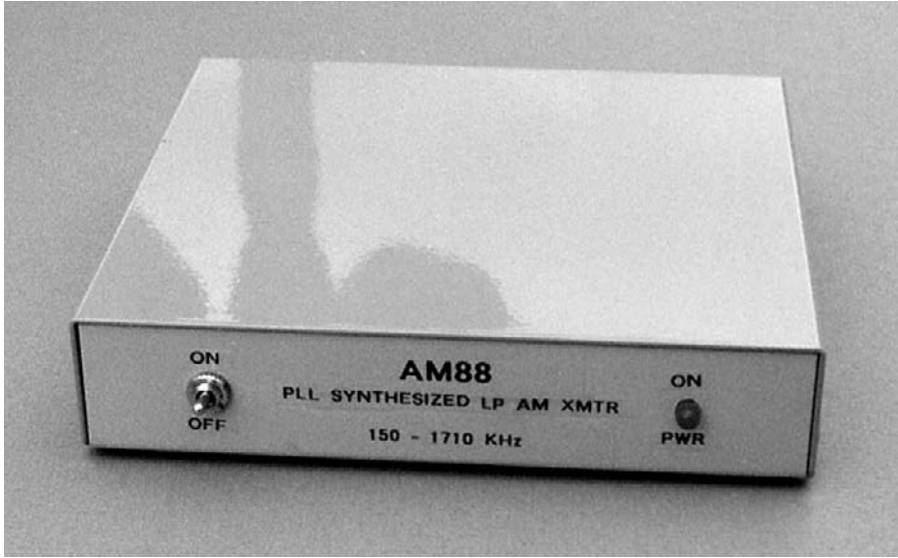

Figure 5-8

Top View of the AM88 in a Metal Case with the Cover Removed



than 250 ma), repeat step 1 because something may be wrong. Nothing should be getting hot, although Q7 will normally run quite warm after a few minutes. If still no errors are found and the current drain is lower than specified, there may be nothing wrong that will cause damage. In this case, proceed with setup and, eventually, any errors will be located. Excessive current and something overheating is a definite warning sign, and in this case the cause should be found before setup is completed.

5. Connect the negative lead of VOM or DVM to ground. Check the following voltages, using the positive lead of meter (12-volt supply is assumed):
 - Jct D4, C6, IC4: 11.4 volts
 - Pin 3 IC: 15.0 volts
 - Pin 7 IC2: 9.0 volts +/- 0.6 volts
 - Emitter of Q7 (TP3): 5.0 volts, varies with R16
 - Collector of Q9: Same as emitter of Q7
 - Collector of Q3: 4–5 volts
 - Collector of Q4: 0.5–1 volts
 - Drain Q5: 8.8 volts +/- 0.6 volts
 - Jct R5, R6, C3: 5.8 volts +/- 0.8 volts
 - Pins 1, 2, 3 IC3: 5.8 volts +/- 0.8 volts all the same
 - Pin 6 IC: 5.8 volts +/- 0.8 volts
 - Pin 7 IC1: varies with R16 and R18 from less than 2.5 to more than 7.5
 - Jct R8, R9, D3; varies with R16 and R18 from less than 1 to more than 1.5

A variation of 10 percent is normal. Remember to allow for meter accuracy and component and supply voltage variations. If any major variations are noted, repeat step 1. Reset any pots moved during testing to their original pre-set positions, except set R16 for +4.5 to +5.0 volts at TP3.
6. Set S1 (dipswitch) for a frequency of 1700 kHz, within 20 kHz if 1700 kHz is busy in your area. (See the following chart for switch settings.) Leave section 12 of S1 OFF. Section 12 is used only for FM carrier-current work and is *never* used for frequency programming. Make sure that jumper J1 in the emitter of Q8 is installed. *Read and understand the programming procedure.*
7. Tune a nearby AM receiver to 1700 kHz, or as in step 4, if 1700 kHz is busy in your area. This should be the same frequency as in step 4. Monitor this channel with your AM receiver as you proceed.
8. Connect a DVM or VOM to TP1 (pin 6 of IC2). You should read almost 9 volts. If you see less than 9 but more than 2 volts, this may still be acceptable. Listen on the AM receiver. Now start rotating C28 to disengage the plates. At some point, the voltage at TP1 should drop. If not, try removing a turn from the end of the 13-turn winding on L1 connected to C2. If you initially saw less than 9 volts at TP1, this voltage should drop immediately upon rotating C2. If the voltage is “stuck” low or will not reach as high as +7.5 (but will change with C28), then you should add a turn to L1. Set C28 for +7.5 volts at TP1. This should occur with C28 set at 10–60 percent mesh. If C28 has to be set to more than 75 percent, add a turn to L1. You should hear a dead carrier (a signal without audio) in the AM receiver at this point. As a further test, disconnect or shut off the DC power. The carrier should simultaneously disappear; it should reappear when power is restored. This checks out the PLL synthesizer and mixer sections.
9. Remove DC power and program a frequency of 128 kHz on the DIP switches. Set S3 and S4 four positions closed, all others open. Next, measure and record the voltage at TP1. This should be 2–4 volts. Verify that rotating C28 will affect this voltage. Reset C28 to get the voltage you just recorded. This checks out the synthesizer range. If the voltage seen at TP1 is too low and

C28 has no effect, then add a turn to L1 and return to step 6. If everything checks out so far, remove excess lead length from L1 and resolder it to the PC board. It is advisable to coat L1 and fasten it to the PC board with a clear lacquer base cement such as Duco cement or Q dope, or clear fingernail polish. Do not use anything with pigment because it may degrade the coil. Hot melt glue is also acceptable for this purpose. After the coating dries and cools, recheck C28 as in step 6 and reset C28 for +7.5 volts at 1700 kHz if necessary.

10. Connect an audio source to the input and adjust R1 for the loudest signal in the receiver before any distortion is noted. Adjust R16 for 4.5–5 volts at TP3 if not done before. This sets the carrier. Then slightly increase the audio drive until distortion is evident. Adjust R18 to just eliminate this distortion. It should now be possible to increase the setting of R1 a little without experiencing much of a change in received audio level, although some compression may be noticed. This checks out the audio limiter circuit. If a scope is available, R16 and R18 can be adjusted for best modulation by observing the modulated carrier across a 56-ohm resistor connected across the RF output terminals.
11. If a scope or RF voltmeter is available, check the voltage across the 56-ohm resistor connected across the RF output terminals in step 3 to verify that the transmitter is producing RF output. About 2 volts rms across 56 ohm or 5.64 volts p-p will be present. This is best observed with an oscilloscope, but a detector probe on your DVM will suffice as a relative indicator. If you cannot perform this task because of lack of equipment, skip this step but confirm that LED D5 lights properly.
12. This completes testing and setup of the AM88. Remove power and audio connections and install the AM88 board in a case, making sure all adjustments are accessible. Set up for the final desired output frequency. See the programming instructions and following sections for more detailed information.

Frequencies and modulation modes are programmed into the AM88 by setting DIP switches either closed or open, in a pattern depending on the desired frequency and mode. Each time the frequency or mode is to be changed, these switches must be reset. At first, this process may seem inconvenient, but in practice, there are often only a few available clear channels in the AM broadcast band, and once set, the frequency will probably not be changed often. The mode settings will probably be rarely changed unless you are doing a lot of experimental work because more than 2000 frequencies can be programmed.

Four DIP switch assemblies and one soldered jumper are used for programming. The soldered jumper is used to permit insertion of a key or a keying circuit for Morse code (CW) operation. If this will never be done, the jumper is installed permanently and left in place. DIP switch S2 and section 12 of DIP switch S1 is used for mode setting (AM, FM, or CW), and if only one of these modes is to be used, S2 can be permanently set or replaced with wire jumpers. S3 and S4 are used to select harmonic filters and are only changed when a large change in programmed frequency is made (see DIP Switch Settings).

Frequency is programmed by entering the desired frequency in binary on sections 1 through 11 of S1. The most significant digit is entered on section 1, the next on section 2, and the least significant digit on section 11. An easy way to get the binary number equivalent of a decimal number is either to look it up in a chart (books on computer science or math references provide these) or, if you have an IBM-compatible PC run-

ning Win 3.X or Win 95, use the Windows calculator that is provided in the accessories group. Use the scientific mode and the online help menus if this ability is not obvious. A chart of commonly used channels is included in these instructions, but it is impractical to list settings for all 2000 or more possible channels. You can also directly calculate the binary equivalent of any number by using the successive division by two method.

For routine Part 15 use, we recommend using as high a frequency as possible. It is a good idea to confine the signal to only the area needed. A 4-foot whip as a radiator will easily allow the signal to cover an average house and is mechanically easy to construct or salvage from a junked TV set. A 4- to 10-foot whip antenna or length of wire in parallel with a 56-ohm resistor may be connected to J2.

Parts List*

Resistors 1/4 W 5%		Capacitors	
R2, R3, R14	4.7k ohm	C1, C22, C31	1 mf 35v elec
R4	220k ohm	C2, C16, C18	150 pf NPO
R5, R6, R8, R9, R45	10k ohm	C3, C5, C13	10 mf 16v elec
R7, R11, R21, R24,		C4, C7, C27	100 mf 16v elec
R25, R34, R37, R42	1k ohm	C6	470 mf 16v elec
R10, R40	100k ohm	C8	.047 mf mylar 50v
R12, R13	390 ohm	C9, C10, C20, C24, C25	0.1 mf mylar 50v
R15, R23, R35	330 ohm	C11	2–20 pf trimmer
R17, R49	6.8k ohm	C12	39 pf NPO
R19	15k ohm	C14, C37, C40,	
R20, R22, R30, R44	2.2k ohm	C42, C43	.0056 mylar
R26, R33	1.5k ohm	C15	470 pf disc
R27, R29, R32	470 ohm	C17	270 pf NPO
R28, R31	3.3k ohm	C19, C21, C23, C48	.01 GMV disc
R36	180 ohm	C26, C30	.01 mylar
R38, R39	56k ohm	C28	2–10 pf trimmer
R41, R43	22k ohm	C29	10 pf NPO
R46	47k ohm	C32, C33, C35, C41	.0033 mylar
R47	220 ohm	C34, C53	.001 mylar
R50, R51	10 ohm	C36, C39	.0039 mylar
		C44, C47	.018 mylar
		C45	
Potentiometers		PT10YH2.5	
R1, R18	10k ohm		
R16, R48	1k ohm		
Diodes		Switches	
D1, D2, D3, D7	1N914 or 1N4148	S1	DIP switch, 12 position
D4	1N4007	S2	DIP switch, 2 position
D5	Red LED	S3, S4	DIP switch, 4 position
D6	MV209		
D8	1N757A		

Build Your Own Low-Power Transmitters: Projects for the Electronics Experimenter

Transistors		Coils and Chokes	
Q1, Q2, Q3, Q4, Q6, Q8	N3904	L1 (2 ft #24 Enam. for L1 needed)	Toroid .375 OD Core
Q5	MPF102	L2	1.5 mhy 240 ma choke
Q7, Q9	MJE180	L3	1000 uhy choke
Integrated Circuits		L4, L7, L8	5.6 uhy
IC1	MC145151-2	L5, L6	68 uhy
IC2	CA3420	L9, L10	6.8 uhy
IC3	MC1458P	L11, L12	10 uhy
IC4	LM7805N	L13, L14	33 uhy
Miscellaneous			
X1 Crystal, 8192.0 kHz, +/- 0.005% Parallel resonant, C=20pf			
1 each PC Board p/n 090997			
1 each 56-ohm 1/4 W carbon resistor for test purposes			

* Because so many parts are necessary, a complete kit of parts for constructing the AM88 transmitter is available from the source mentioned at the end of this chapter. The parts kit includes a drilled and etched PC board and all the parts that mount on it.

DIP Switch Settings

MODE	S1 posn 12	S2-1	S2-2	S3 and S4 posn 1-4
AM Part 15	OFF	OFF	ON	DEPENDS ON FREQUENCY
FM Carrier Current 150-300 kHz	ON	ON	OFF	1, 2, 3, OFF 4 ON
CW Part 15	OFF	OFF	OFF	DEPENDS ON FREQUENCY
CW 1750 mtr 160-190 kHz 1 watt	ON	OFF	OFF	1, 2, 3, OFF 4 ON

Filter Settings

1. S3 and S4 *must* be set to the *same* configurations.
2. *Only one* section each of S3 and S4 switch on at any time.
3. The LED (D5) *must* be lit, or S3, S4 are incorrectly set.

S3, S4: 1 ON; 2, 3, 4 OFF FLTR # 1 FREQ 1200–1800 kHz

S3, S4: 2 ON; 1, 3, 4 OFF FLTR # 2 FREQ 800–1200 kHz

S3, S4: 3 ON; 1, 2, 4 OFF FLTR # 3 FREQ 530–800 kHz

S3, S4: 4 ON; 1, 2, 3 OFF FLTR # 4 FREQ 150–280 kHz

For 280–530 kHz, either use filter #3 setting plus an external low-pass filter to cut off the second harmonic, or the values of L and C in one of the other filters may be changed as needed to suit the application.

Programming

DIP Switch S1 Frequency Settings

Important: Note that a zero (0) signifies that a switch section is ON, and a one (1) signifies that a switch section is OFF.

Suggested and test frequencies are listed. It is impractical to list all possible frequencies. See next section for a method of deriving settings for other unlisted frequencies.

S1 section: Freq kHz	1	2	3	4	5	6	7	8	9	10	11	Notes
128	0	0	0	1	0	0	0	0	0	0	0	Test freq*
140	0	0	0	1	0	0	0	1	1	0	0	
150	0	0	0	1	0	0	1	0	1	1	0	Lowest LW AM Freq
160	0	0	0	1	0	1	0	0	0	0	0	
170	0	0	0	1	0	1	0	1	0	1	0	1750 mtr
180	0	0	0	1	0	1	1	0	1	0	0	LOWFER band
185	0	0	0	1	0	1	1	1	0	0	1	Part 15
186	0	0	0	1	0	1	1	1	0	1	0	1 Watt CW
187	0	0	0	1	0	1	1	1	0	1	1	160-190 kHz
188	0	0	0	1	0	1	1	1	1	0	0	
189	0	0	0	1	0	1	1	1	1	0	1	
190	0	0	0	1	0	1	1	1	1	1	0	
200	0	0	0	1	1	0	0	1	0	0	0	Carrier Current
230	0	0	0	1	1	1	0	0	1	1	0	
256	0	0	1	0	0	0	0	0	0	0	0	
280	0	0	1	0	0	0	1	1	0	0	0	
285	0	0	1	0	0	0	1	1	1	0	1	Highest LW AM Freq
300	0	0	1	0	0	1	0	1	1	0	0	Carrier Current
455	0	0	1	1	1	0	0	0	1	1	1	Common AM IF
512	0	1	0	0	0	0	0	0	0	0	0	
530	0	1	0	0	0	0	1	0	0	1	0	Common TIS Freq**
570	0	1	0	0	0	1	1	1	0	1	0	Low-end AM BC band
600	0	1	0	0	1	0	1	1	0	0	0	
650	0	1	0	1	0	0	0	1	0	1	0	
700	0	1	0	1	0	1	1	1	1	0	0	
750	0	1	0	1	1	1	0	1	1	1	0	
800	0	1	1	0	0	1	0	0	0	0	0	
850	0	1	1	0	1	0	1	0	0	1	0	
900	0	1	1	1	0	0	0	0	1	0	0	
950	0	1	1	1	0	1	1	0	1	1	0	Middle of AM band
1000	0	1	1	1	1	1	0	1	0	0	0	

Build Your Own Low-Power Transmitters: Projects for the Electronics Experimenter

S1 section: Freq kHz	1	2	3	4	5	6	7	8	9	10	11	Notes
1024	1	0	0	0	0	0	0	0	0	0	0	
1053	1	0	0	0	0	0	1	1	1	0	1	
1089	1	0	0	0	1	0	0	0	0	0	1	
1100	1	0	0	0	1	0	0	1	1	0	0	
1200	1	0	0	1	0	1	1	0	0	0	0	
1250	1	0	0	1	1	1	0	0	0	1	0	
1300	1	0	1	0	0	0	1	0	1	0	0	
1350	1	0	1	0	1	0	0	0	1	1	0	
1400	1	0	1	0	1	1	1	1	0	0	0	
1440	1	0	1	1	0	1	0	0	0	0	0	
1500	1	0	1	1	1	0	1	1	1	0	0	NOTE:
1550	1	1	0	0	0	0	0	1	1	1	0	
1575	1	1	0	0	0	1	0	0	1	1	1	In between freqs
1585	1	1	0	0	0	1	1	0	0	0	1	can be useful to
1595	1	1	0	0	0	1	1	1	0	1	1	avoid interference
1600	1	1	0	0	1	0	0	0	0	0	0	
1610	1	1	0	0	1	0	0	1	0	1	0	Common TIS Freq**
1620	1	1	0	0	1	0	1	0	1	0	0	
1630	1	1	0	0	1	0	1	1	1	1	0	
1640	1	1	0	0	1	1	0	1	0	0	0	
1650	1	1	0	0	1	1	1	0	1	0	0	
1660	1	1	0	0	1	1	1	1	1	0	0	
1670	1	1	0	1	0	0	0	0	1	1	0	
1680	1	1	0	1	0	0	1	0	0	0	0	
1690	1	1	0	1	0	0	1	1	0	1	0	Use for setup
1700	1	1	0	1	0	1	0	0	1	0	0	Use for setup
1710	1	1	0	1	0	1	0	1	1	1	0	Use for setup
Top of AM Band												

* Test: Simply programmed frequencies for test purposes, etc.

** Note: TIS = Travel Information Service used for motorist information.

Calculation of the Binary Code for Frequency

Any decimal number can be converted to binary by successively dividing the number by 2 and then separating the remainders from the result. This is best illustrated by an example rather than a rigorous mathematical description.

A number is either odd or even. An even number can be divided by 2 and has no remainder. Adding 1 to an even number results in an odd number and vice versa. For example:

8, 346, and 1500 are examples of even numbers.

9, 347, and 1501 are examples of odd numbers.

$$8 \div 2 = 4, 346 \div 2 = 173, \text{ and } 1500 \div 2 = 750$$

An odd number will have a remainder:

$$9 \div 2 = 4 \frac{1}{2}, 347 \div 2 = 173 \frac{1}{2}, \text{ and } 1501 \div 2 = 750 \frac{1}{2}$$

You divide the number to be converted by 2. If you have a remainder, place a 1 to the right of the result; if not, place a 0 to the right of the result. This signifies that you have (1) or do not have (0) a remainder. This is the *least significant digit (LSD)* of the needed binary number.

*Discard the remainder (1/2) and repeat, continuing until you wind up with a 0. The ones and zeros in the right are the binary equivalent that you need. The final 1 or 0 that you place on the right is the *most significant digit (MSD)*.*

As an example, we want to convert 1585 to binary (1585 is odd):

$1585 \div 2 = 792 + 1/2$	remainder; therefore, place a 1 to the right	1
$792 \div 2 = 396$	no remainder; therefore, place a 0 to the right	0
$396 \div 2 = 198$	no remainder; therefore, place a 0 to the right	0
$198 \div 2 = 99$	no remainder; therefore, place a 0 to the right	0
$99 \div 2 = 49 + 1/2$	remainder; therefore, place a 1 to the right	1
$49 \div 2 = 24 + 1/2$	remainder; therefore, place a 1 to the right	1
$24 \div 2 = 12$	no remainder; therefore, place a 0 to the right	0
$12 \div 2 = 6$	no remainder; therefore, place a 0 to the right	0
$6 \div 2 = 3$	no remainder; therefore, place a 0 to the right	0
$3 \div 2 = 1 + 1/2$	remainder; therefore, place a 1 to the right	1
$1 \div 2 = 0 + 1/2$	remainder; therefore, place a 1 to the right	1

We have successively divided by 2 and have reached 0. The last digit is the most significant digit. The binary number is read out from the *bottom* of the column to the *top* and is:

$$1585 \text{ binary} = 11000110001 \text{ (MSD to LSD)}$$

If a number has less than 11 binary digits, place enough zeros to the *left* of the MSD to result in an 11-digit number. The *LSD must be programmed* into position 11 of S1.

Example: we want 188-kHz output. Convert 188 to binary:

$188 \div 2 = 94$	no remainder; therefore, place a 0 to the right	0
$94 \div 2 = 47$	no remainder; therefore, place a 0 to the right	0
$47 \div 2 = 23 + 1/2$	remainder; therefore, place a 1 to the right	1
$23 \div 2 = 11 + 1/2$	remainder; therefore, place a 1 to the right	1
$11 \div 2 = 5 + 1/2$	remainder; therefore, place a 1 to the right	1
$5 \div 2 = 2 + 1/2$	remainder; therefore, place a 1 to the right	1
$2 \div 2 = 1$	no remainder; therefore, place a 0 to the right	0
$1 \div 2 = 0 + 1/2$	remainder; therefore, place a 1 to the right	1

The result in binary is 10111100; however, this is 8 digits and we need 11 digits, so the number becomes 00010111100, with three extra zeros inserted on the left. These zeros are programmed at S1 switch positions 1, 2, and 3 as “on.” Position 4 will be “off,” 5 will be “on,” positions 6 through 9 will be “off,” and 10 and 11 will be “on.” This sequence is because the chip IC1 has internal pullup resistors on its logic inputs, and any given input line will be at a logic high (1) if the switch connected to that input is “off” (open) and a logic low (0) if the switch is “on” (closed).

Build Your Own Low-Power Transmitters: Projects for the Electronics Experimenter

A kit of parts for the AM88 transmitter consisting of a drilled and etched PC board, complete documentation, and all parts that mount on the board, is available from the following source:

North Country Radio
P.O. Box 53, Wykagyl Station
New Rochelle, NY 10804-0053
E-mail: support@northcountryradio.com
Website: www.northcountryradio.com

Check their website for current price and order form. A hardware kit consisting of necessary jacks, switches, cable, mounting hardware and connectors, as well as a two-tone painted, aluminum case, are also available from North Country Radio.

6. VFO Controlled FM Monaural Transmitter for 88-108 MHz

A simple transmitter that enables the builder to broadcast audio through an FM receiver is described in this chapter. This project is an excellent introduction to low-power transmitters and employs no “trick” circuitry. The complexities of a stereo generator and phase locked loop (PLL) are not present, only the “basics,” consisting of an audio amplifier and RF oscillator. The transmitter will broadcast over a 50- to 200-foot range, depending on antenna size, and will operate from 9- to 12-volt battery supplies. Although it is intended for mono operation, the same circuitry can broadcast stereo if a stereo generator is used to generate a baseband stereo signal; however, being VFO controlled, it is not really optimum for use with digitally controlled FM receivers because some frequency drift is inevitable with any free-running oscillator. A stability of 100 kHz is about what you will get. Simple analog FM receivers with AFC will easily handle drift of this magnitude. As long as no interfering signals are on-channel, the drift should not be a problem, considering the usual applications of this type of low-power transmitter; however, mono audio will likely not often be used for serious audio transmission to this type of receiver anyway. An ideal receiver for use with this type of transmitter would be a basic analog type, such as an inexpensive personal stereo or a “boom box.” This transmitter is also useful for experimenting before committing to a more complex and expensive design.

Often in simple designs, use is made of unpublished or uncontrolled transistor parameters. The variation of collector capacitance with collector voltage is an example. Although it may be specified in curves published by the manufacturer, it is not an “official parameter” specified in the registration of the device. Therefore, other manufacturers’ parts may not behave in the same way, even if the device has the same part number, because generally DC parameters, such as hfe and breakdown voltages, and only a few basic RF parameters, may be required to meet specifications for that type. The use of characteristics such as collector-to-base varactor effect, which are aimed at saving cost and simplifying the circuit, may restrict the circuit to one device type and manufacturer, or even a particular device lot. The experimenter who wants to build such a circuit has therefore little chance of obtaining that device, especially if the design is a few years old. The circuit to be described, although a little more complex than some designs for the same purpose, will work with almost any devices and is very forgiving of parts substitutions.

The transmitter is simple enough, with a fairly low parts count, to build on either perfboard or on a piece of unetched copper-clad PC board material using “ugly bug” construction. Although generally unattractive in appearance, point-to-point wiring using a piece of PC board material is simple, and the copper provides an excellent ground plane for the circuit. No time-consuming PC board fabrication step is needed. The circuit can easily be fitted onto a 2-by-4-inch board and can be smaller if desired. The entire finished unit can be housed in a plastic or metal “experimenter’s

box,” which is available from electronics suppliers, or even an electrical outlet box from your local home repair center. Power can be derived from a 9-volt transistor radio battery or from 6 to 8 AA or AAA cells in a suitable holder.

Examining the schematic diagram shown in Figure 6-1 shows that the transmitter consists of three stages: an audio amplifier, a voltage-controlled oscillator (VCO), and a buffer amplifier. The audio stage takes the audio input in the 20–15000 Hz range and amplifies it by a factor of about five times, and increases in gain at 6 dB/octave above 2.1 kHz to add the needed preemphasis to the audio. This audio is fed to a VCO consisting of a Colpitts oscillator with a varactor diode acting as an FM modulator, and the VCO feeds a buffer stage to bring the output up to about 0.5 mW, which will produce a usable signal up to about 200 feet with a short (6-inch) whip antenna. A zener diode provides a fixed 6 volts to the VCO for improved stability with declining battery voltage. Nine to twelve volts is recommended, although the transmitter will operate down to six volts, but the zener regulator will not function properly at this voltage, and more drift may be expected.

Referring to the circuit diagram, audio input is applied at coupling capacitor C1 and ground. Audio is fed through R1 to audio stage Q1, whose gain is determined by the ratio of R4 and R2 to R1. C2 provides bypassing above 2 kHz, reducing the feedback and increasing the gain as frequency increases; this provides preemphasis. R5 and R3 are bias resistors. Audio appears at the collector of Q1, amplified about five times. This audio is fed to gain control R6 through C3, and potentiometer R6 sets the deviation or modulation level. Audio from the wiper of R6 is fed through C4 and isolation resistor R7 to the varactor-modulator diode D2. D2 is reverse-biased through R8 with about 6.8 volts reverse bias. This sets the capacitance of D1 to about 15 pf. D1 is a 6.8-volt zener diode, with C6 and C7 acting as bypass capacitors to reduce noise and provide an RF ground. The VCO consists of Q2 with associated bias resistors R10, R11, and R12. The VCO is a Colpitts oscillator configuration. This setup has the advantage of reducing the loading on the oscillator frequency-determining circuit by the indefinite and variable transistor parameters, reducing drift caused by the transistor. It is an excellent oscillator when low drift is desired because the transistor input impedance is swamped out by relatively large capacitors C10 and C11. The series combination of C11, C12, L1, and trimmer C9 in parallel with C8 form the main oscillator “tank” circuit. L1 is adjustable with a slug to set the coarse frequency, and C9 is used for fine adjustment.

The varactor diode appears in series with C5, and the total capacitance of about 3.5 pf appears in parallel with C8. Adding this 3.5 pf to the 22 pf of C8 and the

Figure 6-1
Low Power Variable-Frequency Oscillator (VFO) Controlled FM Transmitter

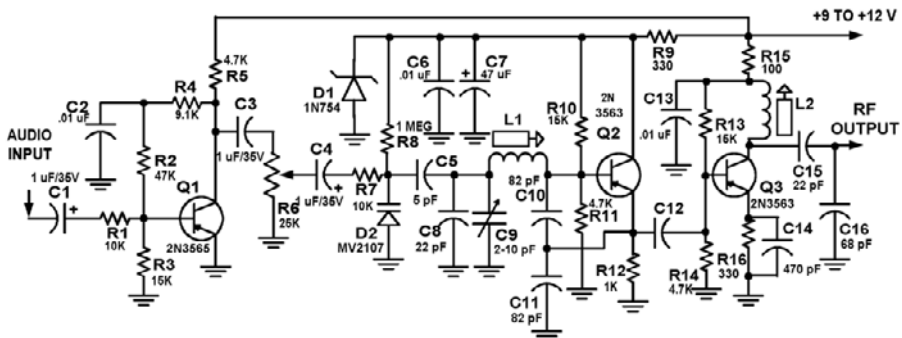

nominal 6 pf capacitance of C9 (variable from 2–10 pf) totals about 31.5 pf, which appears in series with the series combination of C10 and C11 (41 pf). This provides a total effective capacitance of about 18 pf, and L1 tunes with this capacitance. It can be shown that the variation of C10 and C11 caused by the transistor capacitances has only a small effect on the tuned frequency. This contributes to frequency stability. Audio on D2 varies its capacitance, which varies the capacitance of the tuned circuit, causing frequency modulation of the oscillator, with very little AM component. This will be much smaller than that which would result from modulating the VCO transistor Q2 directly in order to vary its collector capacitance. Oscillator output from a low-impedance point (across C11) is fed through C22 to buffer stage Q3. R13, R14, and R16 provide bias for Q3, while R15 suppresses possible UHF self-oscillation in Q3. C13 is an RF bypass, and the output is filtered by tank circuit L2, C15, and C16. RF output is taken from the junction of C15 and C16 and is about 0.5 mW into 50 ohms.

Coil data is given in Figure 6-2 for the construction of L1 and L2. They are not critical, and the coils may have to be adjusted later by adding or removing a turn to obtain operation on your chosen frequency. You can find suitable slugs in the IF and video coils used in older TV receivers and junked CB radios. Data shown is for the low end of the FM band (88–92 MHz), where there is apt to be less competition from higher-power commercial stations. *Do not* operate near and *never, never* above 108 MHz because you could cause interference with aeronautical navigation systems. VOR (VHF omnirange) stations operate just above 108 MHz in some areas of the country. Operation below 88 MHz is also illegal and can cause interference with TV reception in areas where VHF channels 5 or 6 are in use. In particular, TV channel 6 audio subcarrier is at 87.75 MHz, which is very close to the FM band. (Many FM receivers can receive this frequency.) In some parts of the world (i.e., Asia), however, 76–92 MHz is used for FM broadcasting instead of 88–108 MHz.

In order to check out the circuit, check your wiring, and if it is correct, connect 9 to 12 volts positive to the junction of R5, R9, and R15. First, verify that there are 3.5 volts DC on the collector of Q1, 6–7 volts on the collector of Q2, and 9–12 volts on the collector of Q3. There should be 6 volts across D2; if not, it is shorted or installed backwards. There will be about 0.8–1 volt on the emitter of Q2, and from 2–3 volts on the emitter of Q3. These exact values depend on supply voltage and parts tolerances and are not very critical. Set C9 and R6 at midrange. Do not connect any antenna to C15 and C16 until you have checked out the circuit and set it on an unused FM frequency where you will not bother anyone.

Find a clear channel in the lower end (88–92 MHz) using a receiver on the FM broadcast band. Leave the receiver tuned to this frequency. Power up the circuit and slowly adjust the slug in L1 until you hear a sudden reduction of noise in the receiver (quieting). Use C9 as a fine-tuning adjustment if needed. If no signal is heard, try another higher or lower frequency. Next, apply audio (you can use the line output from a CD player or tape deck) to the input, and you should hear it in the receiver. Adjust R6 for best sound quality. Although it will be monophonic, sound quality should be excellent. This completes the checkout process.

Mount the transmitter in a case of your choosing. Your local parts house should stock project or experimenter's boxes, or you can use a small metal, plastic, or even wood box from the craft store or home center. The batteries can be mounted in the same case along with an on-off switch and audio input jack.

Batteries can be either a 9-volt transistor type or 6 to 8 AA or AAA cells. Use alkaline types because they last longer. We favor AA cells because they last a long time and are often available at low prices. One discount store offers a pack of 40

1) WRAP SPECIFIED NUMBER OF TURNS AROUND 8-32 SCREW

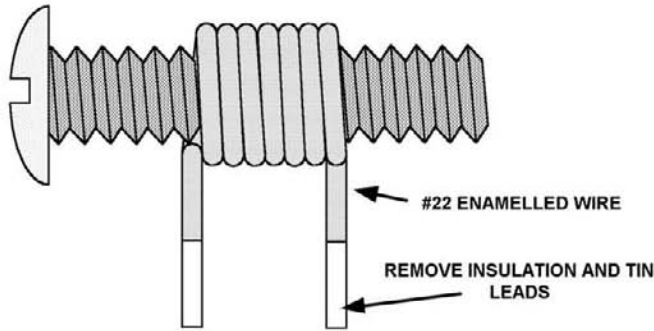
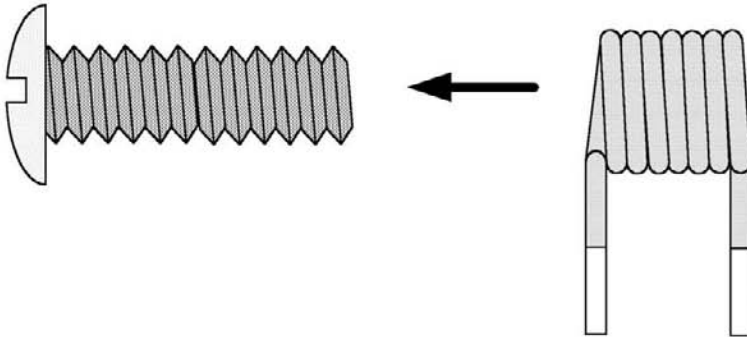
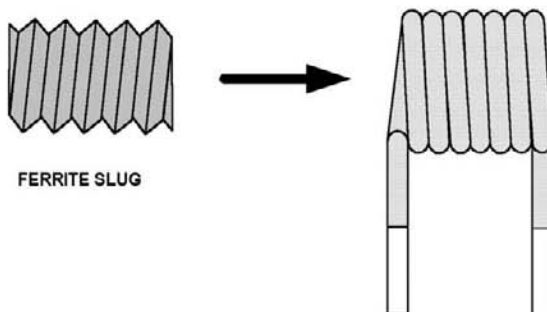

Figure 6-2
Coil Winding for
the FM Transmitter

2) ROTATE SCREW COUNTERCLOCKWISE TO REMOVE SCREW WITHOUT DISTORTING COIL WINDING



3) INSERT THREADED SLUG IN WINDING IN PLACE OF SCREW



good-quality name-brand batteries for \$7.99, for example. Battery holders are available for 6 or 8 cells as needed to fit your case and can be purchased at Radio Shack or one of the mail order houses, or often salvaged from junked electronic equipment. If you wish, you can also wire up an LED power-on indicator, but this will mean a few

milliamperes of extra battery drain. A 2.2K or 3.3K resistor in series with a small red LED should provide adequate indication with a 12-volt battery pack.

The antenna can be a short whip (6 inches) mounted to the case and insulated from it if a metal case is used. For short ranges up to 20–25 feet, often no antenna is needed. Keep the range as short as is practical, the signal on your own property, and do not interfere with any commercially licensed station, and no one will complain about interference.

This Page Intentionally Left Blank

7. Basic FM Stereo Signal Generation Techniques

When FM stereo transmission was introduced in the 1960s, millions of monophonic FM receivers were in use. Whenever anything new is introduced into a mass market, it is desirable not to make existing equipment obsolete and to maintain compatibility with existing equipment. Otherwise, buyer resistance will be met and the new system may not gain acceptance. The new stereo system had to be backwards compatible with mono FM. The new stereo transmissions had to be received by existing mono receivers as monophonic audio, much like color TV transmissions were received as black and white on the then millions of black-and-white TV sets still in use. Therefore, a stereo audio format was necessary, similar in principle to color TV transmission, whereby the main audio channel was transmitted as the sum of left and right (L+R) audio channels, as the main video channel transmitted the luminance (brightness components) portion of the TV picture.

The color is transmitted not as color in itself but only as the information about how it differs from white or neutral grays. Therefore, a black-and-white receiver would simply reject the color signal and use only the luminance component to display a black-and-white image. Similarly, the main audio channel in FM stereo is the total of left and right (L+R) audio signal components. In addition, a signal is transmitted that is the difference of the channels (L-R). By adding the signals, the right channel cancels and the left channel alone appears. By subtracting the (L+R) and (L-R) signals, the left channel cancels and the right channel similarly is now obtained. A mono receiver would reject the (L-R) component and reproduce only the (L+R) component as a mono signal.

The trouble with this idea is that the sum and difference channels (L+R) and (L-R) both are audio, occupying the baseband of 20–15000 Hz. Using analog methods, in those predigital days, there was no way to separate the channels as is. So instead, the difference (L-R) component was superimposed on a subcarrier in the ultrasonic range, where it would be inaudible. A pilot carrier must also be transmitted to assist in demodulating this subcarrier back to audio. The stereo receiver would have to extract this subcarrier and pilot signal and process them to recover the (L-R) difference signal as audio, then perform the adding and subtracting (called *matrixing*) to obtain the separate L and R channels. Then two audio channels (L and R) and two speakers could be used to obtain true stereo reproduction.

A stereo generator module or system must be used to process the incoming audio channels into a form suitable for transmission by a standard FM transmitter on a standard FM channel 200 kHz wide, with 75-kHz peak deviation. The usual preemphasis and deviation limiting must be provided for, and the frequency response of the audio should not be degraded from standard mono transmissions. Because available deviation is limited by FCC regulations to 75 kHz, the L and R channel total audio must not exceed that for an equivalent mono channel. Therefore, each channel

Build Your Own Low-Power Transmitters: Projects for the Electronics Experimenter

can supply half of the peak deviation. In addition, a pilot signal is needed for demodulating the audio subcarrier, and some provision must be made for the use of auxiliary subcarriers, such as Secondary (or Subsidiary) Communications Authorization (SCA) transmissions on 67 or 92 kHz. Therefore, the audio channels must be limited in practice to contributing about 80 percent of the full deviation so there is room left for the pilot and SCA subcarriers. This level difference is hardly noticeable in practice on the received signal. The circuitry needed for all of this processing, although involving several components, is simple and straightforward, involving only low frequencies, and is easily implemented with a few integrated circuits (ICs) and transistors.

Indeed, there once existed an IC that did the whole job (BA1404 or BA1405), but this IC has suffered the fate common to many ICs—manufacturer's discontinuance. For some hobbyists and low-power transmitter manufacturers, this is grim news. The folly in depending on specialized LSI chips that are not second-sourced by at least two other manufacturers is well illustrated here. Thousands of hobbyists' stereo FM transmitters both in kits and individual projects were constructed around the BA1404/BA1405 ICs. Although they may be available in surplus for a few years, their future is doubtful because little mass-market demand for these chips exists. They were fine for low-end uses, but real FM stereo demands performance and signal-to-noise ratios well beyond the capabilities of these chips. We show a circuit of a stereo generator using the BA1405 chip for illustrative purposes only (Figure 7-1); however, it is not difficult to build a much better stereo generator using discrete tran-

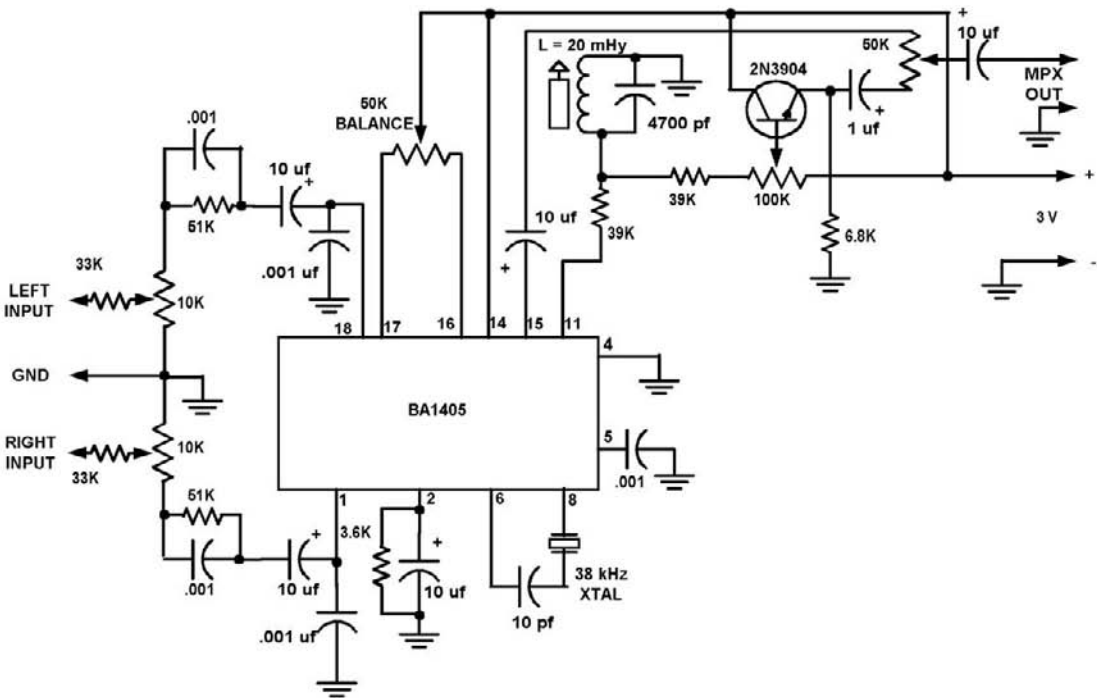

Figure 7-1
Stereo Generator Using a BA1405

sistors and a few “classic” IC devices that are widely available from several manufacturers, together with a handful of resistors and capacitors, that will give “broadcast-quality” stereo sound to a low-power hobby transmitter. In addition, all waveforms are accessible for study and learning how the stereo system works.

The stereo generation process (see Figure 7-2) is as follows: The two input channels L and R are first fed to a preamplifier, where the audio is amplified and preemphasized. This means that higher frequencies are boosted relative to lower frequencies by a controlled amount. This is done as a means of improving the signal-to-noise (s/n) ratio of the received audio. In the receiver, exactly the opposite is done (deemphasis), which reduces high-frequency receiver noise and produces an overall improved s/n and therefore “cleaner” high frequencies. A simple RC lowpass filter circuit is used for this task, and it may be either a distinct RC circuit or incorporated into the frequency response of one of the audio stages. In U.S. FM practice, a single 0 at 2.1 kHz, corresponding to an RC circuit time constant of 75 microseconds, is used. Therefore, below about 1000 Hz, no alteration is made to the audio.

At 1 kHz, a boost of around 1 dB occurs; at 2.1 kHz, a boost of 3 dB; and at 4.2 kHz, a boost of 7 dB is used, and so on at 6 dB/octave until 15 kHz. The audio is then limited in amplitude by a limiter, generally a diode peak clipper, to protect against overmodulating the transmitter. This is done for both L and R channels. Program input should be limited in frequency to 15 kHz to avoid artifacts and aliasing effects and to make the job of the lowpass filter easier in reducing these effects. The stereo generation process assumes that no input frequencies above 15 kHz are present. Next, a lowpass filter is used to reduce audio components above 15 kHz both input and those resulting from any clipping. In some (European) systems, a

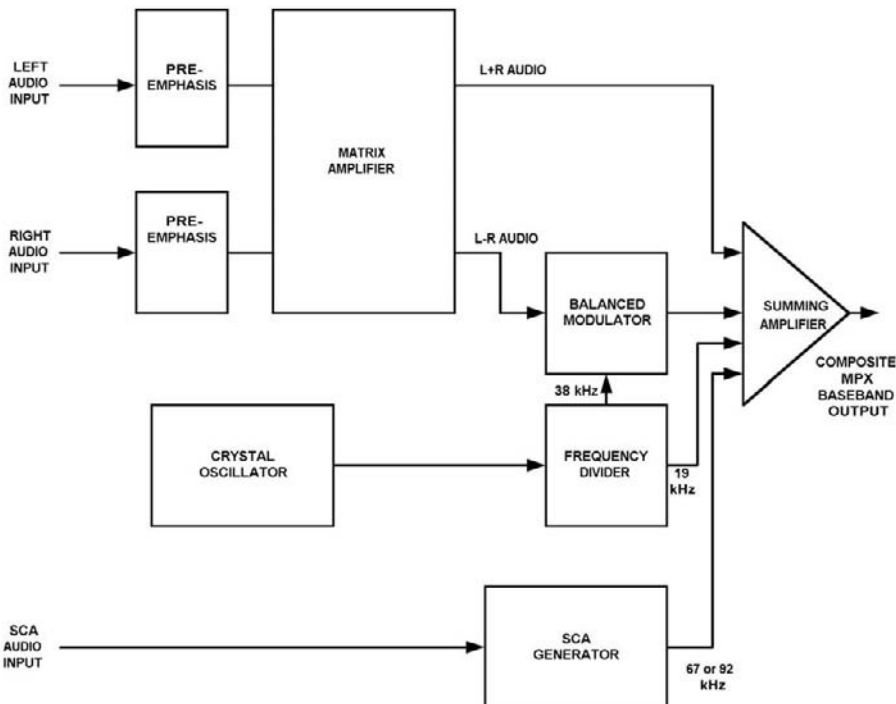

Figure 7-2
Block Diagram of
an FM Multiplex
Generator

preemphasis time constant of 50 microseconds, corresponding to a 0 at 3.15 kHz, is used instead of 2.1 kHz.

Next, the processed audio channels are added and subtracted algebraically in a matrix amplifier circuit. The (L+R) and (L-R) signals are now generated. The (L+R) signal is the main component of the “baseband” signal and is fed to a summing amplifier, where it is combined with other components (to be discussed later). The output of this summing amplifier is fed to the transmitter audio input.

The difference (L-R) signal must be separated in frequency from the (L+R) signal to keep them separated while being transmitted on the same channel. This is done by transforming the (L-R) signal into a double sideband (DSB) suppressed carrier AM signal at a frequency high enough so its lowest frequency components are far above the highest frequency components in the main L+R signal. A balanced modulator circuit is used for this operation (see Figure 7-3). A carrier frequency of 38 kHz has been standardized for this purpose, and a pilot signal of half this frequency at 19 kHz is also generated. The pilot signal can be doubled at the receiver and used to generate a local 38-kHz signal for demodulation of the subcarrier into L-R audio, and it can be used to signify the presence of stereo audio. The pilot carrier is also used by some receivers as a signal to switch from mono to stereo and back to mono if the pilot at 19 kHz falls below a minimum level, indicating insufficient signal for good stereo reception.

For TV stereo audio, 31.468 kHz and 15.734 kHz, which are two times and one times the horizontal scan frequencies, can be used if the audio response is limited to about 12 kHz or so. A DSB suppressed carrier signal is used because if a standard

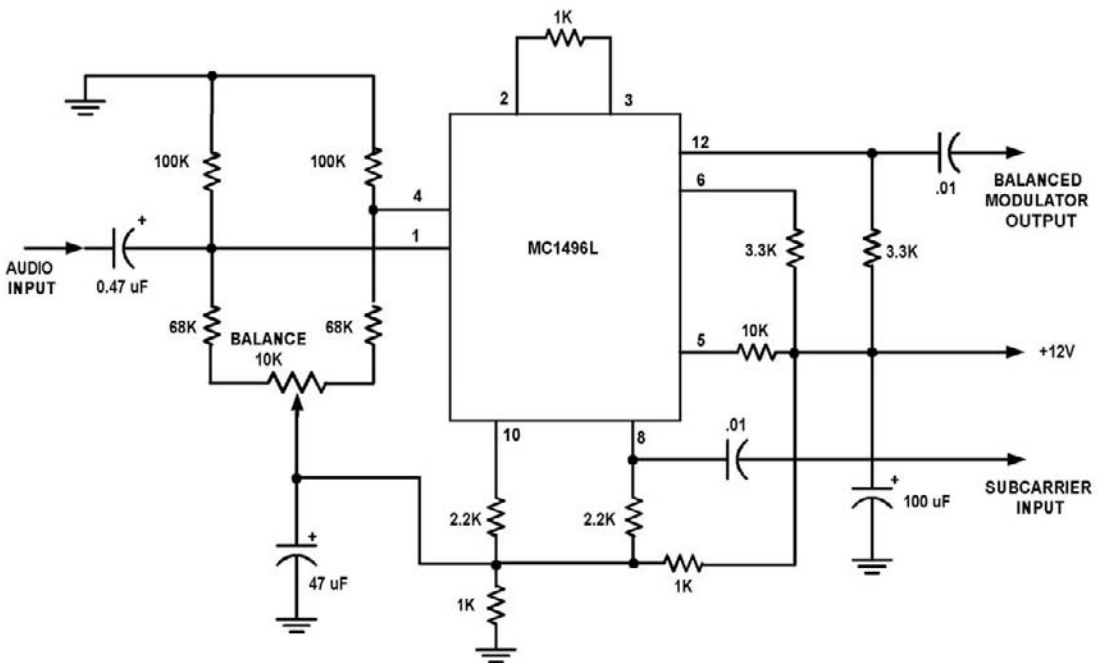

Figure 7-3
Balanced Modulator Circuit Using an MC1496L

AM signal were used, the carrier at 38 kHz would “hog” a large part of the allowable deviation of 75 kHz total permitted. This reaction would reduce the available deviation for the sideband components, which really carry the desired audio information for the FM, reducing the s/n ratio and contributing a filtering problem in getting rid of the carrier component at 38 kHz, while keeping the higher frequency audio components at 10–15 kHz relatively “clean.”

The audio out of the balanced modulator has components from 23–53 kHz. This corresponds to the sum and difference of the audio components at 0–15 kHz with the 38-kHz subcarrier (which is suppressed). This signal, along with the 19-kHz pilot signal, is fed to the summing amplifier.

The pilot carrier and the subcarrier frequencies must be held to close tolerances, preferably within 1 Hz or so. This requirement is not as bad as it sounds, about 52 parts per million (ppm) for the pilot carrier and 26 ppm for the subcarrier. Because the subcarrier is referenced to the pilot, the 52 ppm tolerance at 19 kHz can easily be held with a crystal-controlled oscillator. The 38-kHz signal can be generated and then divided by 2 to get the 19-kHz pilot. Although crystals for 38 kHz are available, they can be delicate and expensive. A crystal in the 2–6 MHz range is by contrast cheaper, more rugged, and easily available. Therefore, the best approach is probably to use a crystal in the MHz range and to use one of the CMOS divider chain chips available to divide the MHz frequency by a power of 2 to get 38- and 19-kHz signals. This approach is used in our circuits to be described in another chapter. In these circuits, a 4.864-MHz crystal is used in an oscillator, and its frequency is divided by 128 to get 38 kHz and then again by 2 to get 19 kHz. Although the outputs from the divider are square waves, the balanced modulator used to generate the subcarrier needs a square wave anyway, and the pilot is inherently filtered by the bandwidth of the audio system. Only two common digital CMOS ICs are used in this circuit, and the cost is very low.

The output from the summing amplifier has the following spectral components:

1. The sum of the L and R channels (L+R) consisting of audio program components from 0 (actually about 20 Hz) to 15 kHz. This is the part received and used by mono FM receivers.
2. A pilot signal at 19 kHz of sufficient amplitude to produce around 10 percent of the total deviation permitted by the transmitter. This signal is used for stereo detection and for regeneration of the 38-kHz subcarrier at the receiver.
3. A DSB suppressed carrier signal having frequency components from 23–53 kHz, which carry the L–R signal needed by the stereo receiver.
4. Optionally, subcarriers at 57, 67, or 92 kHz used for data transmission, or for SCA programming for use by private organizations. These subcarriers generally have 7.5-kHz deviation and carry music or programming with audio quality similar to AM broadcasting.

Therefore, a transmitter that handles FM stereo must have modulation capability up to 100 kHz with reasonable flatness of frequency response. Ideally, frequency response should be flat with constant time delay versus frequency, which implies a linear phase response versus frequency. Distortion, both harmonic and intermodulation, should be kept low to avoid crosstalk and the production of unwanted spurious mixing products, which could cause interference with audio programming. These components may show up as noise, whistles, or loss of separation. Additionally, distortion on the transmission path between transmitter and receiver must be avoided as much as possible for best stereo reception. Multipath transmission effects that occur

Build Your Own Low-Power Transmitters: Projects for the Electronics Experimenter

at VHF frequencies can cause severe distortion and ruin stereo reception. Antennas used with FM stereo transmitters and receivers must have adequate bandwidth (rarely a problem) and enough gain to ensure adequately received signal.

Some representative circuits are shown that can be used as building blocks in a stereo generator system such as that just discussed. Figures 7-4, 7-5, and 7-6 are typical of these systems. Complete systems are shown as parts of the MPX96 and MPX2000 discussions in later chapters.

Figure 7-4
Matrix Amplifier
Used for Stereo
Generation

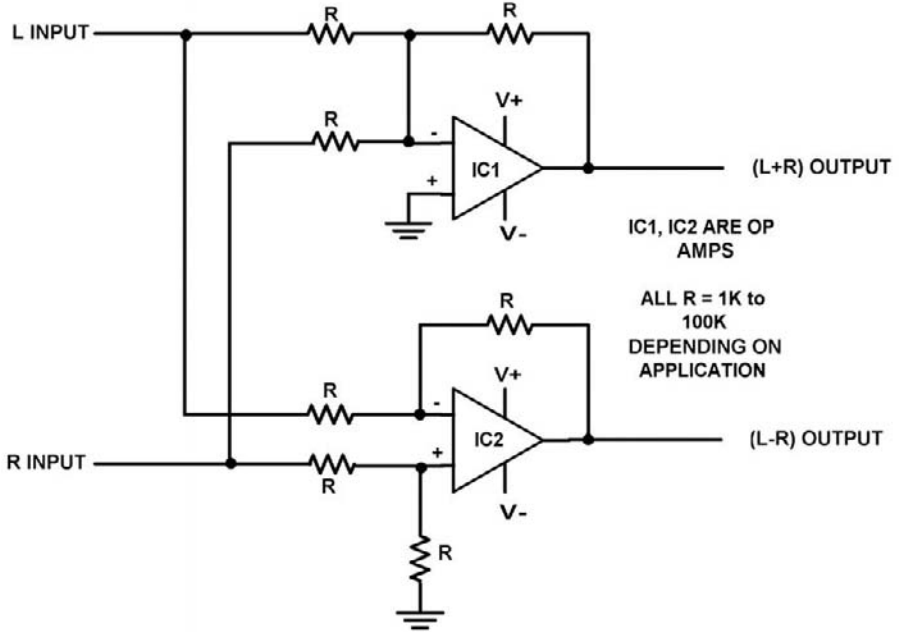
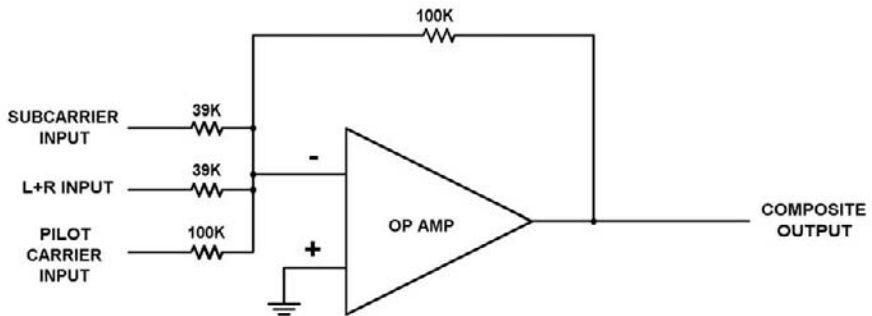

Figure 7-5
Summing Amplifier
Used for Stereo
MPX Generation



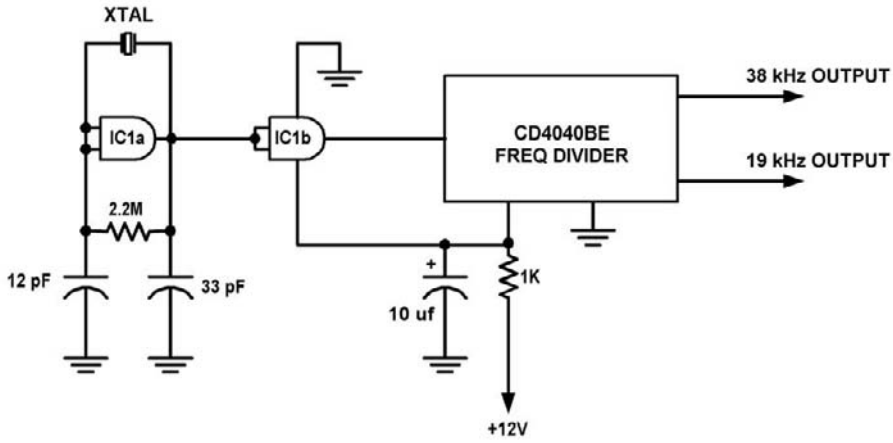

Figure 7-6
Pilot and Subcarrier Generator FM Stereo Multiplex System

This Page Intentionally Left Blank

8. PLL Synthesized FM Stereo Transmitter for 88-108 MHz

Low-power FM transmitters have been a popular hobby item in recent years. They are usually free-running oscillators that are frequency modulated with an audio signal and are used in many applications from wireless mikes to “bugs” and for small home FM radio stations covering 100 feet or so. Stereo operation is also possible using a chip, such as the BA1404, and several parts, but the advance of technology has brought out some new problems in using these gadgets. Digitally tuned receivers are commonplace nowadays, including FM broadcast receivers. Digital receivers are always exactly on frequency and make finding a desired station simple. The traditional analog slide rule dial has largely disappeared from the higher-end FM receivers, replaced by LCD or LED readouts. Therefore, the digitally tuned receiver has no need for fine-tuning or automatic frequency control and cannot generally be tuned off channel. This makes it necessary for received signals to be on frequency. Of course, this is no problem because commercial FM stations must be crystal controlled and held to close tolerances; however, for the user of some simple low-power transmitters, this is a problem because frequency drift is a fact of life for these circuits. It is hard to hold simple LC oscillators to a stability of much better than 0.1 percent, over a reasonable temperature and supply voltage range. At 100 MHz, the middle of the FM broadcast band, this is a drift of 100 kHz.

An analog-tuned FM receiver has no problem receiving the signal as it drifts because the AFC circuit automatically retunes the receiver as needed. A digitally tuned receiver with frequency-synthesized tuning using a phase locked loop (PLL) cannot do this without special circuitry. Commercial FM receivers have no need to do this anyway. Also, the FM band is crowded with many signals in most populated areas, and a free or unoccupied channel is rare at times, so as the low-power FM transmitter drifts, it runs into interference from adjacent channel signals. The solution to this problem is to make the low-power transmitter crystal controlled; however, this is not simple because the 75-kHz frequency deviation needed for FM broadcast work cannot easily be obtained from simple crystal oscillators. It is even difficult to get one-tenth of this (7.5 kHz) and still keep the audio distortion to less than 1 percent. In order to do this, commercial FM transmitters used frequency-multiplier stages and mixers, starting at a low frequency, multiplying up, heterodyning down, and multiplying up again to realize large multiplication factors. In this way, it was possible to get the 75-kHz deviation from a lower-frequency oscillator with a very small deviation.

This traditional method requires a lot of circuitry and is impractical and prohibitively complex and expensive for the hobbyist wishing to experiment with low-power, physically small, simple FM transmitters. Fortunately, another approach is made possible by the use of modern digital IC devices. This chapter describes a simple low-power FM stereo transmitter using PLL techniques, along with a few digital IC devices and analog op-amps, to produce a clean, stable, broadcast-quality FM stereo signal. We call this device the MPX96 low-power FM transmitter.

The MPX96 is a complete PLL-synthesized low-power FM stereo audio link operating in the standard FM broadcast band. It can be operated over the range 76–108 MHz, therefore supporting North American domestic FM and the 76–88 MHz frequency range used in Asia. Channel spacing is 100 kHz, which ensures coverage of all FM frequencies. Both the FM carrier frequency and the multiplex pilot frequencies are crystal controlled, eliminating the drift that is common with uncontrolled LC oscillators. This permits use of this unit with digital PLL receivers. Programming consists of setting a 10-position DIP switch with a binary code corresponding to the desired transmitter frequency. This frequency can be any unused FM channel in your area. Once the frequency is set, the MPX96 will stay on that channel because it is phase locked to an internal crystal oscillator. Audio input can be any line-level source of 0.5–1 volt RMS dual-channel audio (stereo or two individual sources). An onboard tone generator (1.2 kHz) is provided for setup purposes. All seven IC devices in the MPX96 are readily available standard ICs. Circuit setup is simple, with only a VOM needed. A single 12- to 15-volt DC negative ground supply is needed to power the MPX96, and because the current drain is 120 mA, a simple battery pack can be used to power it. RF output is about 10 mW into a 50-ohm load (0.7-volt rms). For export use only, this output can be increased to 150 mW with a simple circuit change. The recommended antenna for U.S. operation is a 12-inch whip antenna shunted with a 56-ohm resistor.

Several years ago, the authors published an article describing an MPX transmitter with a free-running oscillator and an MPX generator using several IC devices to generate an MPX baseband signal. The article appeared in the March/April 1988 issues of *Radio-Electronics*. This circuit worked well, but soon after, the BA1404/BA1405 IC devices appeared, greatly simplifying the task of building an FM stereo transmitter. The BA1405 was similar to the BA1404 but had no RF section on board the chip. Introduced for the purpose of interfacing with after-market CD players to FM stereo auto radios, these ICs were useful for making a simple stereo transmitter. The BA1404 had poor RF stability, and being a “black box” item, it taught little about MPX circuit operation to the experimenter. It also had the disadvantage of requiring low-supply voltage (less than 3 volts) and required a fragile 38-kHz crystal. Presently, the demand for this device has dropped to the point where it is going to be discontinued by its only manufacturer. We considered using this chip until the manufacturer told us it was to be discontinued past July 15, 1996, after a final “lifetime buy” production run was made. Although this chip may be available from distributors and surplus houses, in small quantities, for a few more years, it seemed to be unwise to design a transmitter around a chip with no future. Instead, we developed a simple MPX generator using a simplified version of the well-proven 1988 circuit, adding some improvements and eliminating several setup adjustments.

Two IC devices now handle MPX generation, and a crystal-controlled approach replaces the three large coils originally used. The fragile 38-kHz crystal used by the BA1404 for the purpose of pilot and subcarrier has been replaced by a rugged 5-MHz type in our new circuit, and two common CMOS ICs generate the 38-kHz and 19-kHz signals. As an extra bonus, a 1.2-kHz audio signal is developed in one of the ICs at no extra cost. This signal is useful for test purposes. The total cost is low and, unlike the BA1404/BA1405 approach, all of the MPX signal components are available for observation and experimentation. Actually, we were not too impressed with the BA1404 regarding its overall performance: the need for “glue” circuitry to interface this device to the synthesizer was a drawback, and the RF section proved to be totally unsuitable for a really good VCO. The demise of the BA1404/BA1405 is therefore

no great loss because much better performance can be had with only a few extra parts and conventional IC devices available from multiple sources.

Typical applications of the MPX96 include, but are not limited to, the following:

1. Home audio systems: Listen to your CD player, tape deck, and the like on a pocket stereo while not in the same room as your audio equipment, or outside the house, in the garage, workshop, deck, and so on.
2. Other applications such as private or inhouse broadcast systems for schools, real estate, health clubs, stores, offices, museums, and so forth.
3. Use as a short-range FM station in remote areas where no other FM reception is possible or no suitable stations can be received.
4. For entertainment of groups in which a second language is spoken. Two languages can be carried, one on each channel, for a bilingual PA system, using small pocket stereo receivers. This is useful for churches, fairs, shows, and the like.

Circuit Operation

The MPX 96 uses eight IC devices and five transistors to implement a complete PLL-synthesized FM stereo transmitter. The transmitter can be broken up into several subsystems, which are the audio and MPX generator, the clock, the PLL, and the output amplifier (see Figures 8-1 and 8-2 for reference).

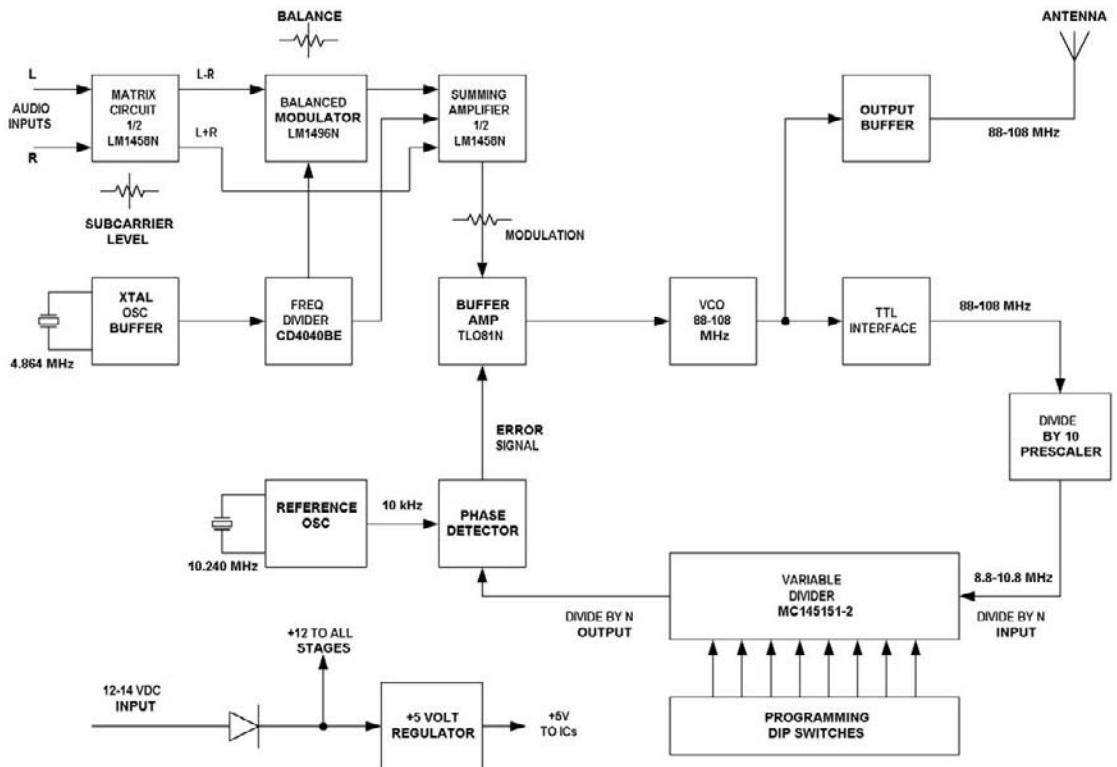

Figure 8-1 Block Diagram of the MPX96 Frequency Synthesized FM Stereo Transmitter

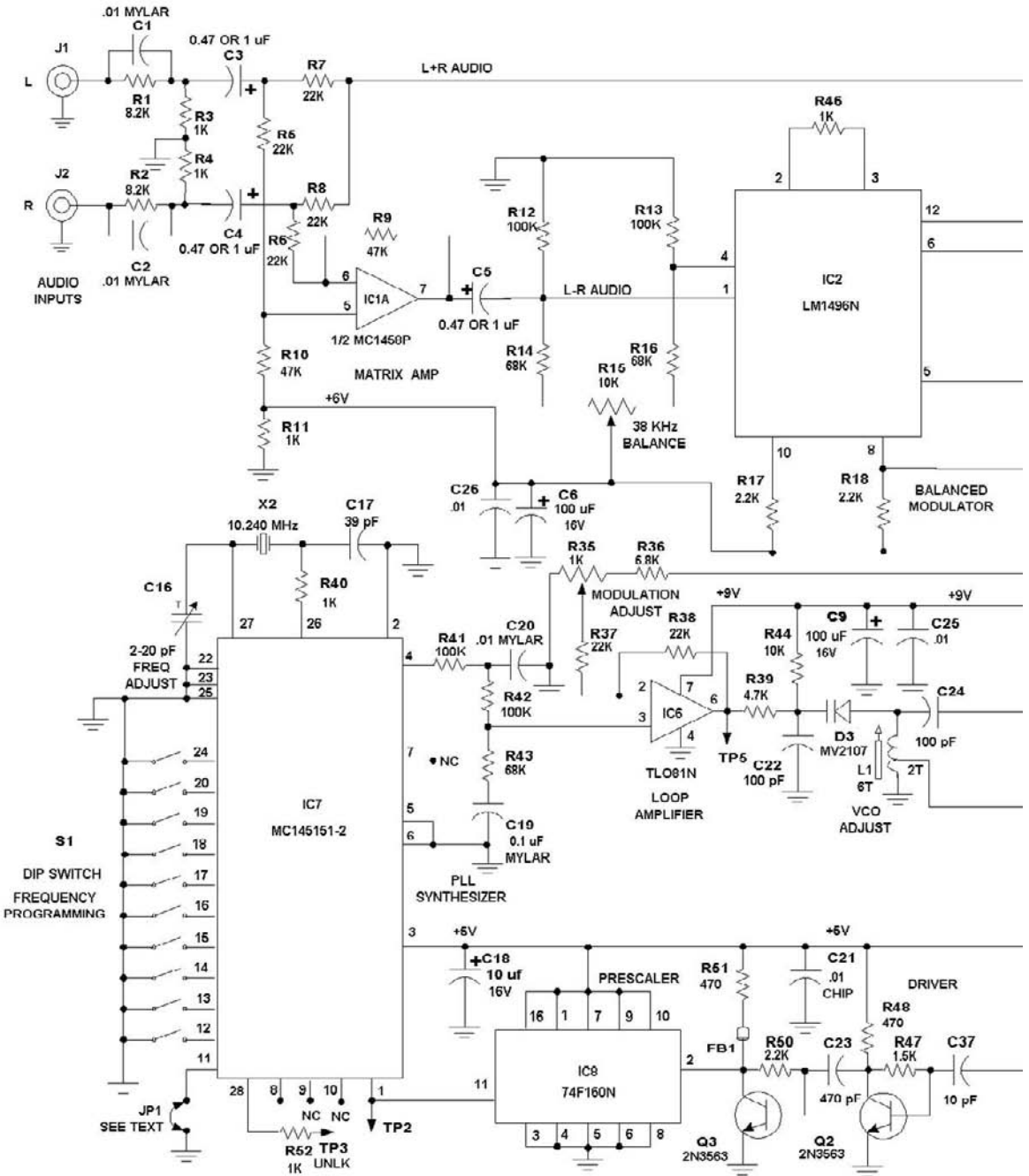
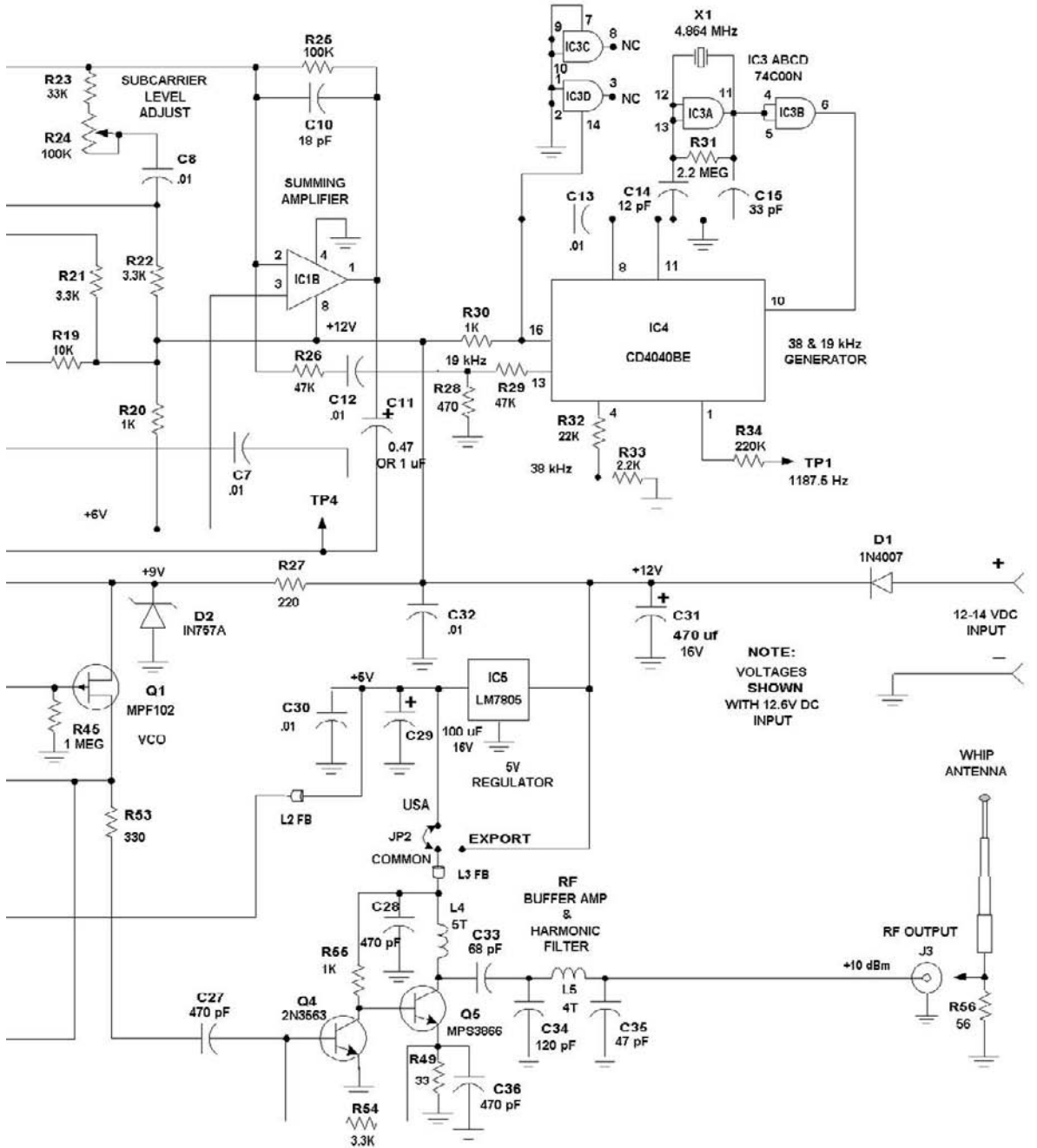

Figure 8-2 Schematic of the MPX96 Frequency Synthesized FM Stereo Transmitter

PLL Synthesized FM Stereo Transmitter for 88-108 MHz



The audio section consists of IC1a and IC1b, a dual op-amp LM1458N, and balanced modulator IC2. Line-level audio inputs of approximately 0.5–1.0 volt RMS (high impedance approximately 10K) connected to both J1 and J2 are fed to an RC preemphasis network R1, C1, R3, and R2, C2, R4, which boost frequency components above 2000 Hz for better signal-to-noise (s/n) ratio. This is done in FM broadcasting to improve the s/n ratio. Coupling capacitors C3 and C4 pass these signals to a matrixing circuit consisting of R7 and R8, and a differential amplifier IC1a, and associated components R5, R6, R9, R10, and C5. The L and R audio inputs are combined by R7 and R8 to form a signal that is the sum of the left and right audio channels (L+R), and this is passed to the summing junction of the multiplex amplifier IC1b, where it is combined with two other signals. One of these signals is the audio subcarrier containing the audio information that is the difference of the two inputs L and R, or (L–R). Note that if the two audio inputs L and R are identical, this signal is 0.

IC1a is configured as a differential amplifier with a gain of about 2, and the L audio input is fed to the noninverting input via R5 and R10. A network consisting of R11 and R20 and bypass capacitors C6 and C26 provides a fixed bias of half the nominal 12-volt supply voltage (+6 volt) to bias both IC1a and IC1b inputs. This avoids the need for separate plus and minus supplies. The R input is fed to the inverting input via R6. The ratio of R9 to R6 sets the gain. R5, R6, R9, and R10 are chosen such that equal gain is obtained for the L and R inputs. Because the R input is inverted in IC1b, the output of IC1b is proportional to (L–R); however, this is still audio, and it cannot be directly combined with the (L+R) signal at the input of IC1b because there would be no way of keeping these (L+R) and (L–R) signals separated.

Therefore, the (L–R) signal is placed on a subcarrier signal well above the audio passband, which extends to 15000 Hz (15 kHz). This is done by producing a double sideband (DSB) signal at 38 kHz, by using a 38-kHz signal and modulating it with the (L–R) audio signal, which also has audio components from 20 Hz to 15 kHz. A DSB signal having sum and difference components of the 38-kHz subcarrier and the (L–R) audio is produced. Because the (L–R) signal has frequencies up to 15 kHz, the subcarrier will have components from 38–15 kHz, or from 23 to 53 kHz. Because the 38-kHz signal has no information, it is suppressed, leaving only the sum and difference sidebands, which have the (L–R) information. The subcarrier is produced by balanced modulator IC2, an LM1496N. This device produces a DSB signal at pin 6 or 12 that is the product of the modulation signal at pin 1 or 4 and the unmodulated (continuous wave, CW) subcarrier signal at pin 8 or 10. R12–R19, R21, and R22 form biasing networks for IC2. A pot R15 is provided for exact balancing of the currents through the internal circuitry of IC2. This provides for exact balance and, when properly adjusted, the 38-kHz subcarrier signal fed to inputs (pins 8 or 10) can be nulled out at the modulator outputs (pins 6 and 12), leaving only the sum and difference products of (L–R) input at pins 1 and 4 and subcarrier at pins 8 or 10.

This is exactly what is wanted. Only one input pin is used for audio, and the 38-kHz subcarrier as the differential input and output capability is not needed for this application. Output is taken from pin 12. This signal is fed to the multiplex amplifier IC2b via C8, level control R24, and R23. The balanced modulator has a gain of about 2, and the differential amplifier has a gain of 2, giving an overall gain of four times in the (L–R) channel. Therefore, for equal (L+R) and (L–R) signals into IC1b, the resistance of R23+R24 should be four times R7 or R8. Therefore, R24 is adjustable to allow these signals to be set equal because IC2 may vary somewhat in gain. R46 sets the gain of IC2 to approximately 2.

In order to recover the (L–R) information at the receiver, a reference is required to recover (L–R) information from the receiver demodulator that will be in correct phase and frequency with the 38-kHz original subcarrier that has been suppressed. Because it would be difficult to filter this information from the subcarrier signal, which might have (L–R) audio components as low as 20 Hz, a different technique is used. Remember that a 20-Hz audio signal would produce 37980 Hz and 38020 Hz subcarrier components, very close to 38000 Hz to cleanly and easily separate from 38 kHz without an expensive filter. Therefore, a signal at half the frequency, or 19 kHz, called the *pilot signal*, is used as a reference instead. The 19 kHz fits into the composite signal well, being halfway between the (L+R) audio maximum frequency of 15 kHz and the lower limit of the (L–R) at 23 kHz. This signal is supplied by the clock generator circuit, which is discussed shortly. This 19-kHz pilot signal is fed to IC1b via coupling capacitor C12 and R26. It has a level about one-quarter of either the peak (L+R) and (L–R) signals. In addition, it is used by most receivers to activate the stereo-mono switchover and the stereo indicator LED. Therefore, three signals are present at the input of IC1b: the (L+R) signal, the (L–R) subcarrier signal, and the pilot signal. Note that if a monophonic receiver were to detect these signals, only the (L+R) portion would be used, which is the sum of the two inputs, and the (L–R) and the pilot signals would be rejected because these are at ultrasonic frequencies and cannot be heard by the human ear. Therefore, this ensures compatibility between mono and stereo, just as black-and-white TV sets can receive color broadcasts and still display a black-and-white picture.

The three signals are added in IC2b and the composite signal appears at the output. R25 sets the overall gain to about 4, and C10 restricts the bandwidth of the stage to less than 100 kHz at 3 dB down. C11 couples the entire signal with components from 20–53 kHz to TP4, R36, and deviation control R35. R35 is used to set the level of the composite signal to the FM modulator, and R36 limits the maximum level to avoid overdeviation.

The clock generator circuit consists of IC3, IC4, and the associated components. It generates a stable 38-kHz subcarrier, a 19-kHz pilot signal, and a 1.2-kHz audio signal for test purposes. For stability, it is crystal controlled. IC3a is one-quarter of a 74C00N NAND gate, connected as an inverter. R31 provides biasing for the input of IC3a, so it will initially bias up in its linear region, acting as an amplifier. A feedback network consisting of crystal X1 and capacitors C14 and C15 provide the conditions for oscillation at 4.864 MHz. Output from this network is fed to IC3b, which acts as a buffer amplifier. IC3c and IC3d are not used, and their inputs are tied to ground. IC3b drives a 12-stage counter and divider IC4, a CD4040, which provides division by 4096 and has outputs from each stage. Thus, a 38-kHz signal ($4864 \div 128$), a 19-kHz signal ($4864 \div 256$), and a 1187.5-Hz signal ($4864 \div 4096$) are produced and are all phase coherent. R29, R28, R32, R33, and R34 reduce the outputs to lower levels because the nominal 7- to 8-volt signals are far more than needed. R30 and C13 provide about 8 volts for IC3 and IC4 and decouple the supply line from any noise generated by this circuit. This circuit uses few parts, allows use of a rugged and inexpensive 5-MHz-range fundamental crystal, eliminates the fragile and expensive 38-kHz crystal used in other approaches, such as the BA1404, and supplies a nominal 1.2-kHz tone for audio test purposes at no extra cost.

The PLL synthesizer section uses an MC145151-2 LSI chip. This chip contains a reference oscillator, reference divider, charge pump phase detector, and variable divider that can be programmed for divide ratios of 3 to 16384. The reference divider is programmable, by hardwiring pins, at various fixed ratios that are mostly powers

of 2. In this application, it is set up to divide by 1024 so that a standard 10.240-MHz crystal will provide a reference frequency of 10 kHz. This sets the resolution of the synthesizer. The maximum input frequency that this chip can directly handle is approximately 12 MHz worst case. The FM broadcast band has channels at 200-kHz spacing. In the United States and Canada, they start at 88.1 MHz and increment in 200-kHz steps (i.e., 88.3, 88.5, 88.7, and so on to 107.9 MHz). In many parts of the world, channels with even 100-kHz spacing (i.e., 90.0, 90.2, 90.4, and so on) are common, and in some parts of Asia, frequencies as low as 76 MHz are used. This circuit covers all of these frequencies, but in the interest of optimum synthesizer performance considering cost limitations and circuit simplicity, the tuning range has been restricted to about 8 MHz without need for the VCO to be reset. This is well worth the slight inconvenience of resetting one adjustment. The synthesizer supports all channels between 76 and 108 MHz in 100-kHz increments.

In order to eliminate a microprocessor and display, the frequency desired is set by use of an onboard 10-section DIP switch S1. A binary code is used. The desired transmitter frequency is determined, and its binary equivalent is set using the DIP switches. Normally, once a clear channel is found or determined, the transmitter is set here and left alone. In most populated areas, there are relatively few clear channels, and in some major U.S. cities, they are rare, so unlike a receiver, there is little need to reset frequency often. Additionally, most low-power FM units such as this one operate between 88–92 MHz. Therefore, a microprocessor and display is overkill and relatively useless in this application. Actually, the synthesizer can cover a wider range than the 76–108 MHz specified, but it has not been tested for this purpose; however, it should work down into the HF range (below 30 MHz) with suitable design changes in the loop filter network, VCO, and output buffer amplifier. Higher frequencies are best handled by using suitable frequency multipliers. These modifications are not discussed and are left to the experimenter.

Because IC7 will handle only about 12 MHz, IC8, a 74F160 ACP, is employed as a prescaler to divide the VCO frequency (76–108 MHz) by 10. The synthesizer will thus see 7.6–10.8 MHz in 10-kHz steps, one-tenth of the transmitter frequency. IC6, a CA3420 CMOS op-amp, acts as a buffer amplifier for the PLL phase detector and provides a very high impedance for the sample and hold circuit, minimizing 10-kHz reference frequency sidebands and allowing smaller capacitors to be used in the compensation network. It also provides an easy method for injection of audio signals into the VCO for directly modulating the carrier frequency. VCO Q1 feeds a buffer amplifier Q2 and Q3 to interface with the prescaler IC8 and drives output buffer amplifier Q4-Q5.

The circuit of the PLL synthesizer operates as follows: Q1, an MPF102 FET, is configured as an oscillator whose frequency is determined by L1 and the capacity of varactor diode D3, and the circuit stray and FET input capacitance. R45 and D3 provide bias for Q1. C22 RF grounds the anode of D3, which is fed a variable DC bias from R44 and R39. Depending on this DC bias and the position of the slug in L1, this will be anywhere from 76–108 MHz. Oscillator signal is taken from the source of Q1. Part of this signal is passed to amplifier stages Q2 and Q3. C37 feeds signal to Q2, which is connected as a wideband feedback stage with R47 and R48 for feedback and bias. C23 couples the output of this stage to the base of Q3. R51 and R50 bias this stage and a signal large enough to drive IC8, a 74F160 TTL decade counter, which appears at the collector of Q3 and pin 2 IC8. A signal of one-tenth the frequency appears at pin 11 of IC8. This signal is fed to the variable programmable divider section of IC7. This divider is programmable via S1 to divide between 760 and 1080, which is equal to the desired output frequency times 10.

For example, if a frequency of 89.7 MHz is desired, then the divide ratio is programmed as 897 via the setting of S1. The internal variable divider produces a signal to be fed to the phase detector at the transmitter frequency divided by 8970 because we have 10 times from the prescaler IC8 and 897 times from the programmable divider, or a product of 8790. Meanwhile, the phase detector is fed a 10-kHz reference signal derived from an internal reference oscillator and divider, which uses external components R40, C17, X2 (10.240-MHz crystal), and trimmer C16. These parts determine the oscillator frequency. C16 is used to set the frequency exactly to 10.240 MHz. An internal divider divides this by 1024 and produces the 10-kHz reference. The output frequency accuracy depends on having an exact 10 kHz, which in turn needs an exact 10.240-MHz crystal oscillator frequency. The phase detector generates a voltage, which depends on the relative phase difference between the reference and variable divider output waveforms.

For example, suppose the divider output starts to lag the reference. This implies that the divider, and hence the VCO frequency, is tending to go lower. In this case, the phase detector produces positive-going pulses and feeds these to the sample and hold network R41, C20, R42, R43, and C19. C19 is charged to a higher DC voltage. A high-impedance CMOS voltage amplifier consisting of IC6, R37, R38, R39, and R40 produces a positive-going output, which is fed to D3 via R39 and R44, causing the oscillator frequency to increase. The opposite result happens if the VCO drifts higher, causing the divider output to lead the reference. Then D1 is biased with a negative-going change in DC bias and causes the VCO to lower its frequency. In this way, the VCO frequency is locked to the reference frequency and will not drift. It will be exactly equal, in kHz, to 100 times the programmed divide ratio. In our case, we have programmed 897, so the output frequency will be 100×897 or 89700 kHz (89.7 MHz).

Modulation is accomplished by injecting audio from the MPX amplifier into IC6. Instead of being returned to ground, R37 is fed from potentiometer R35. Therefore, an audio voltage is superimposed on the voltage to varactor D3. Because the bandwidth of the synthesizer loop is less than 20 Hz, the relatively high audio frequencies are not “corrected out,” and as long as no DC component is injected (assuming symmetrical FM, which is the usual case), the variations in frequency undermodulation are averaged out. The resultant modulation is clean and low in distortion because the VCO has a dynamic range of several volts, and a 1 volt change produces about 1 MHz frequency variation. Therefore, only about 100–150 mV peak to peak of audio is needed for full modulation. The VCO is highly linear over such a small range.

A transmitter output signal of about 10 mW is produced by amplifying a portion of the VCO signal. Signal from the VCO is fed via R53 and C27 to a feedback pair Q4-Q5 and associated components R49, R54, R55, and C36. In this stage, the signal is amplified to the final output level and then fed to a matching network and harmonic filter L4, C33, C34, L5, and C35. Output is at 50 ohms, and it is recommended to terminate the transmitter into a load (R56) and use a simple 12-inch whip as a radiator, as required, to confine the signal to only that area needed. C28 and L3, a ferrite bead, provide decoupling of the supply line.

IC5, a 5-volt regulator, supplies DC to IC6, IC7, and the output amplifier. L2, C18, and chip C21 provide DC line decoupling for the prescaler and PLL IC7. C29 and C30 provide additional decoupling and transient decoupling. The audio and clock sections IC1–IC4 operate directly from 12 volts, and the VCO and IC6 are supplied with +9 volts from zener regulator D2, R27, and decoupling capacitors C9 and C25. D1, C31, and C32 supply filtering of the 12-volt DC input, which may be from 11–15 volts in actual use. Exceeding this voltage may cause damage, and less

than 11 volts may result in the PLL not functioning. Also, excess noise on the DC supply line may cause this noise to be heard on the transmitted signal as interference and hum.

Construction Procedure

Before beginning construction, familiarize yourself with the PC board and the layout. Read and understand the circuit description. It makes things a lot easier when you understand what is going on. Obtain all of the parts as detailed in the parts list. A kit is available from the source mentioned at the end of this chapter and is recommended because a PC board and all parts on it are included. Use good lighting while assembling your transmitter. A magnifier is also useful. Note that grounded leads of resistors are to be soldered on both sides of the PC board. This task is essential for good grounding. A chip capacitor C21 is also mounted under the PC board. This step will be done later. (See Figures 8-3 through 8-6.)

Figure 8-3
Solder Side and
Component Side
of the PC Board
for the MPX96

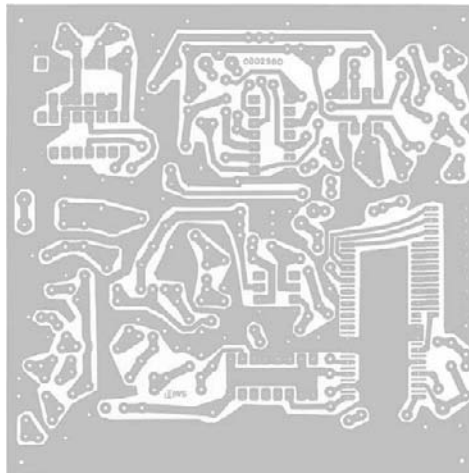

SOLDER SIDE

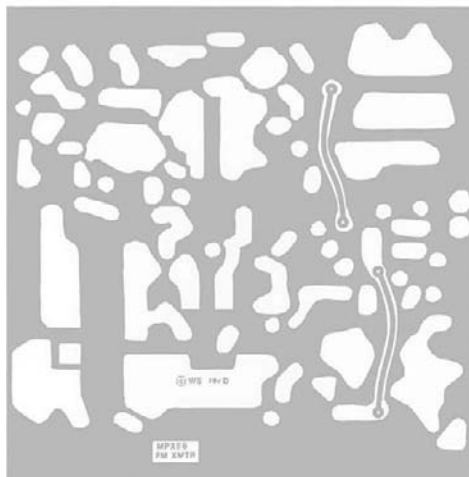

**COMPONENT
SIDE**

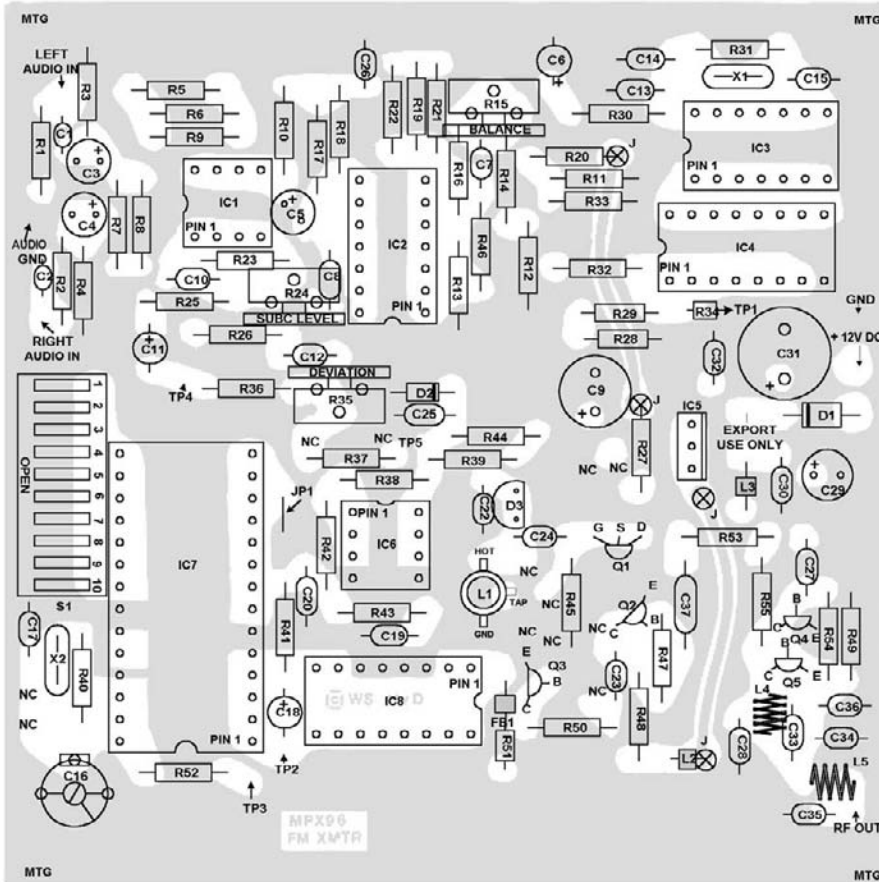

Figure 8-4
Parts Layout Diagram of the MPX96
Frequency Synthesized FM Stereo Transmitter

Except where access may be difficult later, *do not* solder any connections until as many components as possible are inserted. All coils are installed after components are inserted and soldered in, but this is the only exception. *All* parts are mounted tight and close to the board, with no exceptions. This step is important for reducing audio noise pickup and for proper operation of the high-speed digital and RF circuits. It also gives a professional appearance to the finished board. Use only rosin core solder, with low residue preferred. *Do not* use acid core solder or any kinds of paste fluxes. A hot, small, pencil iron is best. (See instructions for chip capacitor mounting in the Appendix. Figure 8-5 shows coil fabrication details.)

Do not solder any connections on the bottom of the board until you are instructed to do so. It is best to begin construction by inserting all resistors in the PC board. Make sure that the correct values are inserted. Next, solder all top ground connections. Install all diodes, carefully observing polarity. Next, install all capacitors. Make sure to observe polarity of all electrolytic capacitors. Accidental reversal will cause a malfunction and possibly damage to the circuitry. If you are in doubt about the value or coding of a specific part, measure it if you can. Install all transistors. Some may have preformed leads. Ignore this and, if needed, straighten out the leads for best fit. Make sure the flat side faces the direction shown in the layout. Be careful with Q2 and Q3 because these may be different than preformed leads seem

Figure 8-5
Coil Data for the
MPX96 Fre-
quency Synthe-
sized FM Stereo
Transmitter

1) VCO coil

Wind 6.5 turns #22 enamelled wire on an 8-32 X 1" or longer screw thread. This acts as a mandrel to shape the coil. Bend leads and form as shown.

The top end is ground. Holding coil as shown, in screw thread, scrape the enamel from the wire and tin with solder a spot 1.75 turns from the top end. Using a fine-tipped iron, solder a 1-inch piece of bare tinned wire to this spot to form the tap for the source of Q1. Use a left-over component lead as shown so it can be fitted into the PC board.

Using screw as a handle, install the coil in the PC board so bottom turn is about 1/8 inch (3 mm) or less from the board surface. Solder all three leads. Be careful not to melt the solder on the coil tap.

Remove screw and install threaded slug into the coil.

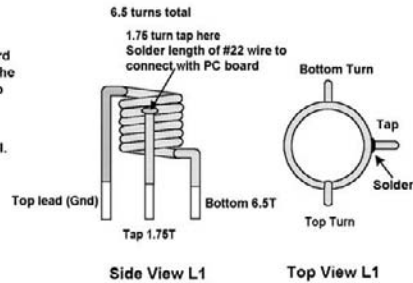
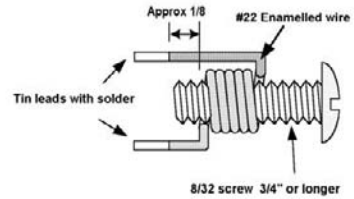

2) L2 and L3

These are simply a length of bare wire passed through ferrite beads as shown. Use leftover lead clippings. Install in PC board as shown.

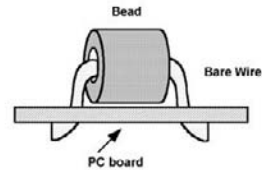

3) L4 and L5

Wind on 8-32 screw as for L1. Use #22 enamelled wire. Tin and form leads as shown. Install in board using screw as a holding tool. Remove screw after installing coil in board. These coils have no slugs or taps.

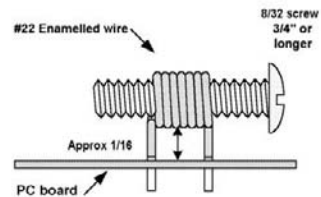

to indicate. If Q2 and Q3 have preformed leads, straighten them with pliers to permit correct orientation. Install trimmer C16 and potentiometers R15, R24, and R35. Preset C16 to 25 percent capacitance (plates one-quarter meshed). Preset R15, R24, and R25 to halfway (or center). The MPX96 will operate with the initial settings of these trimmers well enough to enable testing and setup. Install the crystals X1 and X2. Using scissors, trim crystal leads to 3/16ths inch and install. *Do not* use diagonal cutters because the mechanical snap produced can actually break the crystal elements.

Install ICs, being *extremely careful* about the correct orientation. If you are a bit squeamish about soldering them and/or having to remove them in the future, you can use low-profile DIP sockets. These are not necessary, but if you prefer to, you can use them. Carefully check all work done so far for accuracy and orientation. Now trim all component leads to length if not done yet, and solder all bottom connections made so far. Do not plug up any unused holes yet. Carefully fabricate coils L1, L4, and L5, and then install them in the PC board. Use an 8-32 screw to hold the coils

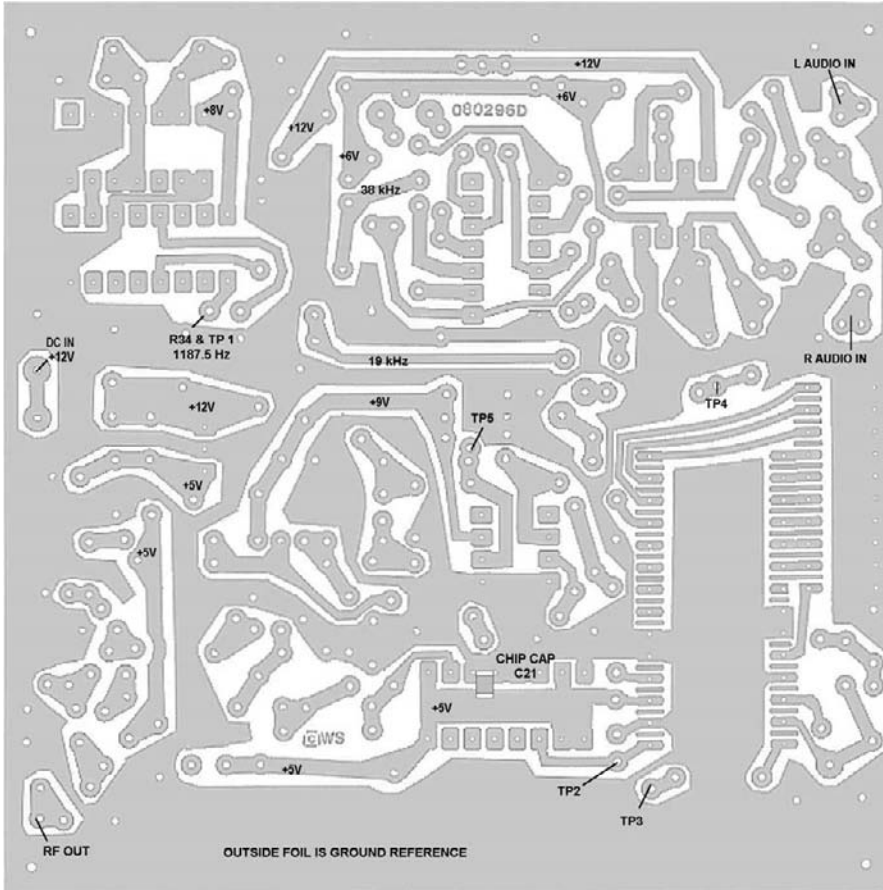

Figure 8-6
MPX96 PC Board
Solder Side Show-
ing Test Points
and Voltages

during the installation procedure. After installing coils, remove the screw and insert the slug fully in coil L1. (Use the coil-winding table for information.) Fabricate the ferrite bead chokes L2 and L3. These are simply wires passed through ferrite beads. Install them in the PC board. Install C21 (.01 uf chip) on the *underside* of the PC board. (Refer to the detailed chip mounting instructions in the Appendix.) Carefully inspect all work completed so far. Look for solder shorts, poor joints, missing parts, incorrect parts orientation or placement, and so forth. You are ready to check out the board once everything is satisfactory.

Test and Setup Procedure

Setup and test is simple, but you will need the following items:

- DVM or analog VOM (preferable) 20K/volt or better
- Power supply 13.2 volts DC regulated, low ripple. (Nine AA, or C or D cells connected in series, make a good supply and are recommended if you have no other supply. *Do not* use a wall-type transformer because these are poorly regulated and may cause bad hum or damage to the circuitry.)
- FM broadcast receiver, stereo with headphones

Build Your Own Low-Power Transmitters: Projects for the Electronics Experimenter

- CD player, tape deck, or any other line-level stereo audio source
- Stereo patch cable for audio connections
- Clip leads as necessary

The setup procedure is as follows:

1. Carefully inspect the PC board for shorts, missing or wrong parts, IC and transistor orientation, polarity of diodes and electrolytics, and any assembly mistakes, such as missing or poor solder connections.
2. Connect the 13.2-volt power supply to D1 and ground. Connect the positive lead of VOM or DVM set on 1-ampere scale to the positive supply lead; negative meter lead to D1. If your supply has a meter that measures current, the VOM or DVM is not needed. In this case, connect the positive supply lead directly to D1. Connect the negative supply lead to the PC board ground. Observe the current drawn; this should be about 120 mA. If current is appreciably less (less than 100 mA) or more (more than 140 ma), repeat step 1 because something may be wrong. Nothing should be getting hot, although IC5 normally runs warm after a few minutes. If satisfactory, remove the VOM or DVM from the positive side of supply (if used) and directly connect D1 to the positive supply terminal. Set the VOM or DVM to read voltages of 0–15 volts DC.

3. Connect the negative lead of the VOM or DVM to ground. Check the following voltages, using the positive lead of meter (13.2 volts supply is assumed):

Jct. D1, C34, IC5: 12.6 volts

Pin 16 IC8: 5.0 volts

Pin 3 IC7: 5.0 volts

Collector of Q5: 5.0 volts

Collector of Q4: 1.6 volts

Collector of Q2: 2–3.5 volts

Collector of Q3: 2–3.5 volts

Drain Q1: 8.5 volts

Pin 7 IC6: 8.5 volts

Jct. R11, C6, R20: 6.4 volts

Pin 7 IC1: 6.4 volts

Pin 1 IC1: 6.4 volts

Pin 16 IC4: 8–10 volts

A variation of 10 percent is normal. Remember to allow for meter accuracy and component and supply voltage variations. If any major variations are noted, repeat step 1.

4. Set S1 (dipswitch) for a frequency of 88.1 MHz, or thereabout if 88.1 MHz is used in your area. If you want to produce even channels, install JP1 and set for 88.0 MHz. Next, connect the DVM or VOM across pins 1 and 4 (polarity does not matter) of IC2 and adjust R15 for a zero voltage reading. Use the lowest scale you can.
5. Tune a nearby FM receiver to 88.1 MHz (88.0 if using even channels) or a closely unused channel if 88.1 MHz is busy in your area. This should be the same frequency as in step 4. Monitor this channel as you proceed.

6. Set the plates of trimmer capacitor C16 at 25 percent mesh and R15, R24, and R35 at center. Set the slug in L1 so it is fully inserted. Connect the VOM or DVM to TP5 (pin 6 of IC6). Listen on the FM receiver. Now start backing out the slug with a nonmetallic screwdriver. Watch the meter. The meter will initially read about 8–9 volts. As you back out the slug further, a point should be reached where the meter reading starts to decrease. At this time, the FM receiver should suddenly quiet down, and you will hear the carrier. As you adjust the slug, the carrier should still be heard in the receiver. Set the slug so the voltage at TP5 is 3–4 volts. The stereo indicator light on the FM receiver should be lit. If not, adjust R35 toward maximum until it lights, then go a little further. The receiver should be quiet. Remove the 13.2-volt supply. The stereo indicator on the receiver should drop out, and the receiver noise should reappear. If everything is correct so far, the next step is to test the unit with an audio signal input.
7. Connect a 12-inch antenna to the RF output J3 (jct. L5 and C35) and apply a stereo audio signal to inputs J1 (left) and J2 (right). Reconnect the DC supply and listen to the FM receiver. You should hear the audio in the receiver. Adjust R35 to bring the received level to that comparable to other local stations in your area.
8. Confirm stereo operation by connecting audio tone test point TP1 first to the left channel, then the right channel, using a clip lead. The signal should follow in the receiver. Adjust R24 for best separation, as necessary. If R24 seems to have little effect, leave it in the middle position. This completes basic setup, and you can skip to step 13. If you are fussy and have access to test equipment, continue with step 9.
9. Connect a frequency counter to J3 (RF output) and adjust C16 for exactly 88.1000 MHz, or whatever frequency you have programmed.
10. Connect a counter or scope to TP1 and check for a 1187.5-Hz square wave. This will then verify that the pilot and subcarrier frequencies are 19 and 38 kHz, respectively. You can verify this, too, if you are curious, but it is not necessary.
11. Using a scope connected to TP4, adjust R15 for minimum 38-kHz subcarrier feedthrough. Temporarily kill the 19-kHz pilot by grounding the Jct. of R28, R29, and C12, in order to make this easy to see.
12. Using a sinewave audio generator of 1.5-volts p-p and a frequency of 1000 Hz, check for waveforms shown in Figure 8-7 at TP4, with the left, right, and finally both inputs connected to the audio generator. Adjust R24 for best compliance to the figures. Some compromise may be necessary because the optimum setting for the L channel and R channel may be slightly different as a result of normal circuit and component tolerances. Split any residual minor difference between the L and R channels so each has equal error.
13. Set the slug in L1 so that 3 volts are obtained at TP5 at the lowest desired operating frequency (usually 88.1 MHz). Reprogram S1 for around 94.5 MHz and verify that the voltage at TP5 is above 7 volts and still varies with slug setting. This step checks out the synthesizer frequency range. Note that the slug may be almost out of the winding; this is acceptable. Secure it with clear lacquer, cement, hot glue, or a drop of wax.
14. Set up for final desired output frequency. See the programming instructions for more detailed information.

Figure 8-7
Waveform at Test Point 4 with a 1 kHz Sine Wave Audio Input

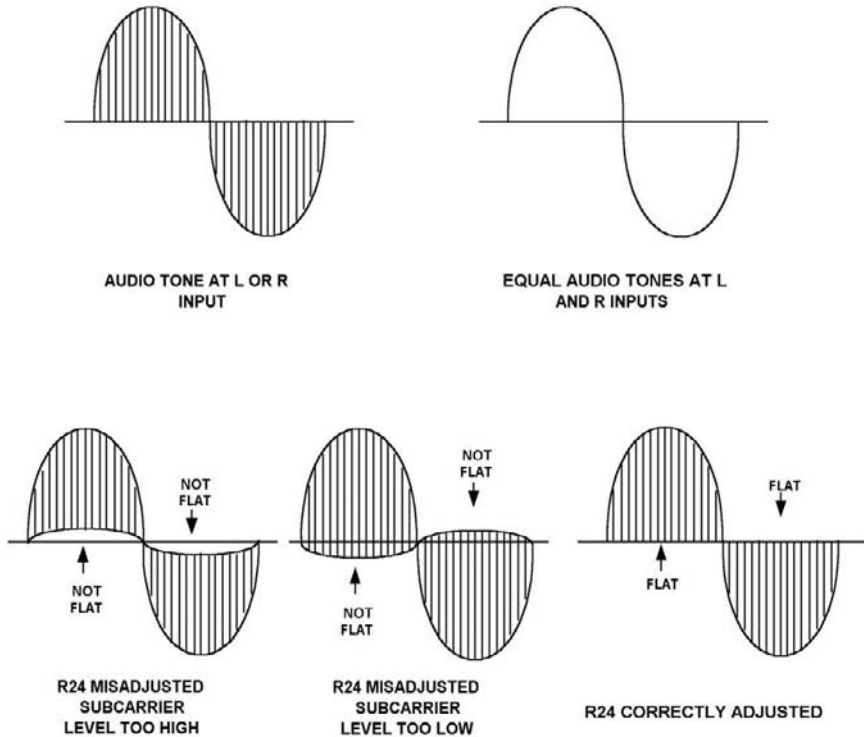

Packaging Considerations

The transmitter may be mounted in almost any case that will accept a PC board of 4-by-4 inches (102-by-102 mm). About 1 inch (25 mm) of height should be allowed. Either metal or plastic can be used and, because no significant heat is produced, ventilation is not critical, although it is a good idea to allow some airflow if possible. Make sure that any metal is at least 1/4 inch (6 mm) away from the bottom of the board. If a plastic case is used, it is a good idea to line the bottom of it with copper or aluminum foil to act as a ground plane for the antenna. In addition, a ground bus of some sort is needed with a plastic case. In our prototype, we used a plastic case with removable front and rear panels. The rear panel was removed, and a substitute one was made from ordinary double-sided G-10 PC board stock. This rear panel had the audio input jacks, DC power connector, and RF output jack mounted onto it, and the copper foil was in turn grounded to the main PC board with short wire connections.

This technique enabled very short leads for the audio input connections so no shielding was needed. RCA phono jacks were used for audio connections, a 2.5-mm jack for DC power, and a BNC connector for RF output. Be sure to ground the shell of the RF output connector with a short (1 inch or 25 mm) lead to the ground foil on the PC board. Remember to keep RF leads short, less than 1 inch, as just mentioned. Audio connectors should be grounded to the audio ground (see layout) and audio leads shielded or kept short to avoid RF pickup and possible distortion. Metal or plastic standoffs can be used to mount the PC board to the case. Antennas can be fashioned from almost any suitable arrangement. We used a replacement cordless phone antenna that collapses to 4 inches (102 mm) and mounted it with epoxy into a

BNC male connector, which, with a right-angle fitting, makes a neat, compact antenna. The power supply should be a regulated 13.2-volt DC type. The type commonly sold for powering CB radios and hobby projects should be fine if it has low ripple. Batteries can also be used, but they wear out eventually. For short periods when continuous use is not contemplated, however, batteries are excellent and do not introduce possible hum that can occur with AC-operated supplies. Run-of-the-mill wall-transformer types are definitely not recommended because they are generally poorly regulated and filtered, and excessive voltage that some units may provide can damage the MPX96 circuitry.

Frequency Programming

Frequencies are programmed into the MPX96 by setting 10 DIP switches either closed or open, in a pattern depending on the desired frequency. Each time the frequency is to be changed, these switches must be reset. At first, this process may seem inconvenient, but in practice, there are often only a few available clear channels in the FM broadcast band, and once set, the frequency will probably not be changed often. More than 320 frequencies are possible, and if direct readout is desired, a microprocessor and display are required (the MPX2000, shown in the next chapter, has this feature). This option is actually not necessary, because once a frequency is chosen, the microprocessor serves no further function. The elimination of the microprocessor also greatly reduces the parts count and allows the same money to be spent on better-quality components and circuitry, where it will count toward better RF and audio performance.

Ten DIP switches and one soldered jumper are used for programming. The soldered jumper is used to determine whether odd (88.1, 88.3, 88.5, . . . MHz) channels used in North America, or even (88.0, 88.2, 88.4, . . . MHz) channels used in Europe and other parts of the world are to be produced. This setting is determined during construction and is easily changed. This jumper is JP1 and is located on the circuit board near IC7. If JP1 is not installed, odd channels are generated. If JP1 is installed, even channels result. JP1 causes a given DIP switch setting to produce a frequency 100 kHz *lower than indicated*. So, if 88.4 is desired, install JP1 and use settings for 88.5, and so forth.

To derive the necessary switch pattern, proceed as follows:

1. Choose the desired frequency (e.g., 89.9 MHz).
2. Multiply by 10, or simply remove the decimal point so a whole number between 760 and 1080 results. In our case, this number is 899.
3. Convert this number to binary. This calculation can be performed by the traditional method of successive division by 2, and using the remainders (see a textbook on basic computer science about how to do this) or by looking in a table. Many math reference books have tables of binary equivalents as well. A table is supplied for 88–93 MHz and several other frequencies as a guide. In between, frequencies can be interpolated.
4. Ignore the least significant digit because this corresponds to JP1 and will be 0 (ground or logical zero) if JP1 is installed, or 1 if not installed (open, high, or logical 1). This corresponds to the logical level of pin 11 of IC7.
5. With the remaining binary number consisting of ones and zeros, set DIP switch position 10 with the first significant digit (0 = closed and 1 = open), set position 9 with the second, position 8 with the third, and so forth until all

switches are set. Verify that the frequency generated is correct using a receiver or counter.

6. Check the voltage at TP5 for 3–7 volts DC. Adjust L1 to bring the voltage into this range. If several frequencies are desired, set L1 so that the lowest frequency produces 3 volts at TPA spread of 7–8 percent (depending on circuit tolerances) in frequency is possible without resetting L1. This covers about one-third of the FM broadcast band. In order to reach the highest frequencies (102–108 MHz), it may be necessary to remove the slug in L1. To reach the lowest frequencies (76-MHz region), the slug in L5 must be screwed all the way in. For typical operation in the 88–92 MHz range, the slug may be only about two turns into coil L1. Secure the slug with a drop of cement or wax as previously described. *Do not* attempt operation above 108 MHz because this range is used by aircraft navigation and communication systems. Interfering with navigational and communications signals in this range could conceivably endanger safety and life or cause an accident.

Applications

The MPX96 is useful anywhere short-range, low-power FM audio links are needed. It is far superior to free-running FM transmitters and will not drift off channel, and it is perfectly compatible with digitally tuned FM receivers. It is also useful as a teaching aid, unlike low-end units using a BA1404 or other “black box” IC, because it allows access to all MPX signal waveforms and observation of the signal generation process. The circuit is adjustable for optimum performance, and if no test equipment is available, it works well with default settings, so anyone can get satisfactory results with only a VOM or a DVM. In the United States and certain other countries, signal radiation must be kept to a level low enough to not exceed specific field-strength levels and not interfere with other stations using the FM broadcast band.

Figure 8-8
Completed PC
Board of
MPX96—The Pro-
gramming Switch
is in the Fore-
ground

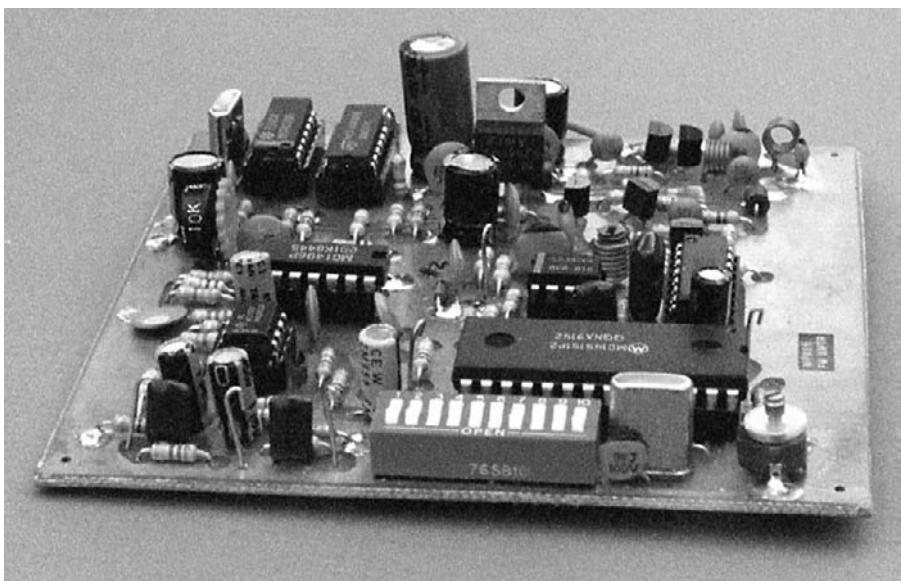

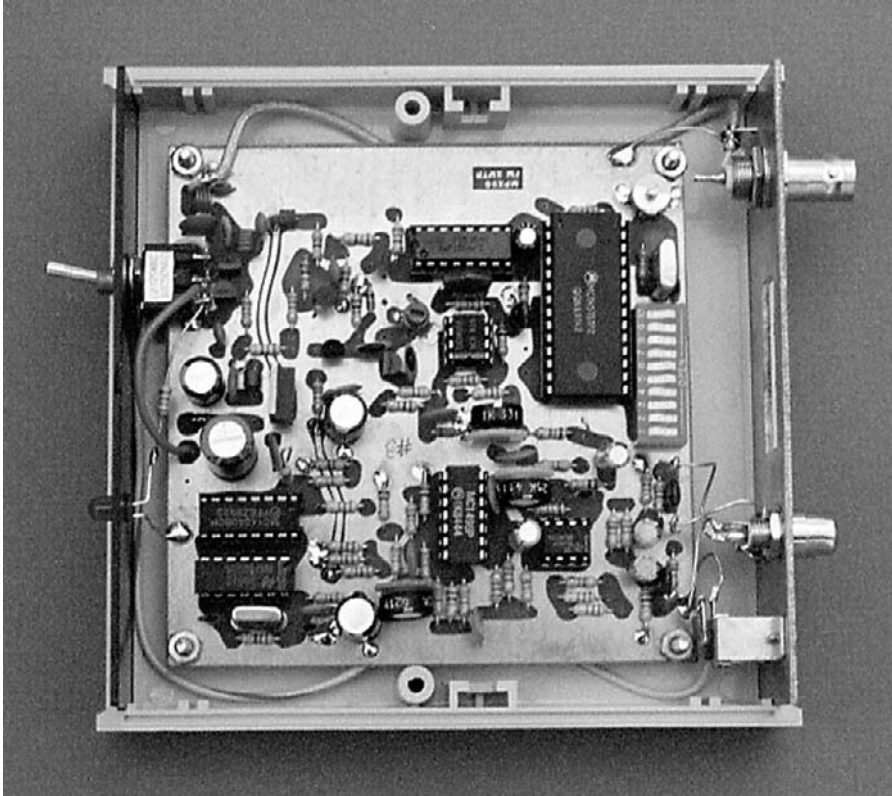

Figure 8-9
Top View of the
MPX96 Mounted
in a Suitable Plas-
tic Case

Check with the applicable laws in your country, such as the FCC or DOT rules and regulations. In the United States, Part 15 of the FCC rules and regulations applies. If you have no easy way to measure field strength, keep the power as low as you can and use only a simple antenna, as short as possible. The MPX96 provides a +10 dBm signal (10 mW) into 50 ohms, running 5 volts on the output amplifier. This power is more than adequate for covering an average property, and only a 12-inch antenna is needed. It is recommended to terminate the output of the transmitter in a 56-ohm resistor, connecting the antenna to the hot side of the termination. This will yield a usable range of 50–200 feet with a typical pocket stereo receiver.

For best results, a relatively clear channel is necessary. The PLL helps tremendously by keeping the signal on frequency. In large metropolitan areas, it may be difficult or impossible to find a clear channel. In this case, try using an in-between channel (i.e., even 100 kHz in the United States and odd 100 kHz in areas using even channel allocations). You might also try to get between two weak stations if possible; however, this can be impossible for digitally tuned receivers, but analog (continuously tuned) receivers will have no problem. Many lower-end pocket stereos are still analog. It is best to operate between 88–92 MHz because this part of the bandwidth is used by lower-powered stations.

Do not set deviation control R35 too high because distortion and interference with other stations may result. Typically, R35 is set at about 75 percent of full open when a typical line-level input (0.5–1.0 volt RMS) signal is fed into J1 and J2. *Do*

not exceed this level because distortion and loss of separation will result. In order to avoid hum, make sure the MPX96 is properly RF grounded, especially if a whip antenna is used.

Operation Outside the United States

For export use, where regulations permit, the voltage on the output buffer can be raised as high as 15 volts, with up to 150 mW output possible, but this output (which is not legal in the United States) is not guaranteed in any way. In this case, a matched antenna should be used and L4 adjusted by compressing or expanding the turns for maximum output. This may allow up to 1 mile or more range, depending on local terrain, if a properly matched antenna is used. Keep the antenna at least 25–30 feet (8–10 meters) from the MPX96 when operating above the 10-mW RF output level because it is possible that stray RF feedback from antenna-to-transmitter circuitry might cause instability and loss of lock in the PLL circuit. Remember, however, that the MPX96 is strictly an entertainment device and is not meant for commercial broadcasting; therefore, no guarantees of any kind can be offered or any technical assistance provided for export use, the details of which must be worked out by the individual user.

Frequency Programming Chart

Note: S1 has 10 rocker switches labeled 1 to 10.

- A “1” corresponds to switch section open (logical 1).
- A “0” corresponds to switch section closed (logical 0).
- S1 sets the logic levels at the programming inputs of IC7.
- Frequencies are shown for U.S. allocations (odd channels), with J1 not installed and pin 11 IC7 at logical 1.
- For operation on even channels, install J1 so pin 11 IC7 is at ground or logical 0. Subtract 0.1 MHz from the frequency indicated in the chart (i.e., 88.1 settings will produce 88.0, 92.5 will produce 92.4, etc.).

Freq. MHz	1	2	3	4	5	6	7	8	9	10
88.1	0	0	0	1	1	1	0	1	1	0
88.3	1	0	0	1	1	1	0	1	1	0
88.5	0	1	0	1	1	1	0	1	1	0
88.7	1	1	0	1	1	1	0	1	1	0
88.9	0	0	1	1	1	1	0	1	1	0
89.1	1	0	1	1	1	1	0	1	1	0
89.3	0	1	1	1	1	1	0	1	1	0
89.5	1	1	1	1	1	1	0	1	1	0
89.7	0	0	0	0	0	0	1	1	1	0
89.9	1	0	0	0	0	0	1	1	1	0
90.1	0	1	0	0	0	0	1	1	1	0
90.3	1	1	0	0	0	0	1	1	1	0
90.5	0	0	1	0	0	0	1	1	1	0
90.7	1	0	1	0	0	0	1	1	1	0

PLL Synthesized FM Stereo Transmitter for 88-108 MHz

Freq. MHz	1	2	3	4	5	6	7	8	9	10
90.9	0	1	1	0	0	0	1	1	1	0
91.1	1	1	1	0	0	0	1	1	1	0
91.3	0	0	0	1	0	0	1	1	1	0
91.5	1	0	0	1	0	0	1	1	1	0
91.7	0	1	0	1	0	0	1	1	1	0
91.9	1	1	0	1	0	0	1	1	1	0
92.1	0	0	1	1	0	0	1	1	1	0
92.3	1	0	1	1	0	0	1	1	1	0
92.5	0	1	1	1	0	0	1	1	1	0
92.7	1	1	1	1	0	0	1	1	1	0
92.9	0	0	0	0	1	0	1	1	1	0
93.1	1	0	0	0	1	0	1	1	1	0
93.3	0	1	0	0	1	0	1	1	1	0
93.5	1	1	0	0	1	0	1	1	1	0
93.7	0	0	1	0	1	0	1	1	1	0
93.9	1	0	1	0	1	0	1	1	1	0
94.1	0	1	1	0	1	0	1	1	1	0
94.3	1	1	1	0	1	0	1	1	1	0
94.5	0	0	0	1	1	0	1	1	1	0
94.7	1	0	0	1	1	0	1	1	1	0
94.9	0	1	0	1	1	0	1	1	1	0
95.1	1	1	0	1	1	0	1	1	1	0
95.3	0	0	1	1	1	0	1	1	1	0
95.5	1	0	1	1	1	0	1	1	1	0
95.7	0	1	1	1	1	0	1	1	1	0
95.9	1	1	1	1	1	0	1	1	1	0
96.1	0	0	0	0	0	1	1	1	1	0
96.3	1	0	0	0	0	1	1	1	1	0
96.5	0	1	0	0	0	1	1	1	1	0
96.7	1	1	0	0	0	1	1	1	1	0
96.9	0	0	1	0	0	1	1	1	1	0
97.1	1	0	1	0	0	1	1	1	1	0
97.3	0	1	1	0	0	1	1	1	1	0
97.5	1	1	1	0	0	1	1	1	1	0
97.7	0	0	0	1	0	1	1	1	1	0
97.9	1	0	0	1	0	1	1	1	1	0
98.1	0	1	0	1	0	1	1	1	1	0
98.3	1	1	0	1	0	1	1	1	1	0
98.5	0	0	1	1	0	1	1	1	1	0
98.7	1	0	1	1	0	1	1	1	1	0
98.9	0	1	1	1	0	1	1	1	1	0
99.1	1	1	1	1	0	1	1	1	1	0
99.3	0	0	0	0	1	1	1	1	1	0
99.5	1	0	0	0	1	1	1	1	1	0
99.7	0	1	0	0	1	1	1	1	1	0
99.9	1	1	0	0	1	1	1	1	1	0
100.1	0	0	1	0	1	1	1	1	1	0
100.3	1	0	1	0	1	1	1	1	1	0

Build Your Own Low-Power Transmitters: Projects for the Electronics Experimenter

Freq. MHz	1	2	3	4	5	6	7	8	9	10
100.5	0	1	1	0	1	1	1	1	1	0
100.7	1	1	1	0	1	1	1	1	1	0
100.9	0	0	0	1	1	1	1	1	1	0
101.1	1	0	0	1	1	1	1	1	1	0
101.3	0	1	0	1	1	1	1	1	1	0
101.5	1	1	0	1	1	1	1	1	1	0
101.7	0	0	1	1	1	1	1	1	1	0
101.9	1	0	1	1	1	1	1	1	1	0
102.1	0	1	1	1	1	1	1	1	1	0
102.3	1	1	1	1	1	1	1	1	1	0
102.5	0	0	0	0	0	0	0	0	0	1
102.7	1	0	0	0	0	0	0	0	0	1
102.9	0	1	0	0	0	0	0	0	0	1
103.1	1	1	0	0	0	0	0	0	0	1
103.3	0	0	1	0	0	0	0	0	0	1
103.5	1	0	1	0	0	0	0	0	0	1
103.7	0	1	1	0	0	0	0	0	0	1
103.9	1	1	1	0	0	0	0	0	0	1
104.1	0	0	0	1	0	0	0	0	0	1
104.3	1	0	0	1	0	0	0	0	0	1
104.5	0	1	0	1	0	0	0	0	0	1
104.7	1	1	0	1	0	0	0	0	0	1
104.9	0	0	1	1	0	0	0	0	0	1
105.1	1	0	1	1	0	0	0	0	0	1
105.3	0	1	1	1	0	0	0	0	0	1
105.5	1	1	1	1	0	0	0	0	0	1
105.7	0	0	0	0	1	0	0	0	0	1
105.9	1	0	0	0	1	0	0	0	0	1
106.1	0	1	0	0	1	0	0	0	0	1
106.3	1	1	0	0	1	0	0	0	0	1
106.5	0	0	1	0	1	0	0	0	0	1
106.7	1	0	1	0	1	0	0	0	0	1
106.9	0	1	1	0	1	0	0	0	0	1
107.1	1	1	1	0	1	0	0	0	0	1
107.3	0	0	0	1	1	0	0	0	0	1
107.5	1	0	0	1	1	0	0	0	0	1
107.7	0	1	0	1	1	0	0	0	0	1
107.9	1	1	0	1	1	0	0	0	0	1
Export Frequencies										
76.1	0	0	1	1	1	1	1	0	1	0
80.1	0	0	0	0	1	0	0	1	1	0
84.1	0	0	1	0	0	1	0	1	1	0
87.1	1	1	0	0	1	1	0	1	1	0
87.3	0	0	1	0	1	1	0	1	1	0
87.5	1	0	1	0	1	1	0	1	1	0
87.7	0	1	1	0	1	1	0	1	1	0
87.9	1	1	1	0	1	1	0	1	1	0

Parts List

Resistors 1/4W+/-5%		Capacitors	
R1, R2 R3, R4, R11, R20	8.2 Kohm	C1, C2, C20	.01 mf mylar 10%
R30, R40, R46, R52, R55	1 Kohm	C3, C4, C5, C11	0.47 or 1 Uf/35V elec
R5, R6, R7, R8		C6, C9, C29	100 uf/16V elec
R32, R37, R38	22 Kohm	C7, C8, C12, C13	
R9, R10, R26, R29	47 Kohm	C25, C26, C30, C32	.01 uf disc
R12, R13, R25, R41		C10	18 pf NPO
R42	100 Kohm	C15	33 pf NPO
R14, R16, R23, R43	68 Kohm	C16	2–20 pf trimmer
R15	Trimpot, PT2.5YH 10 Kohm	C17	39 pf NPO
R17, R18, R33, R50	2.2 Kohm	C18	10 uf/16V elec
R19, R44	10 Kohm	C19	0.1 uf mylar 10%
R21, R22, R54	3.3 Kohm	C21	.01 uf chip, 60 X 120
R24	Trimpot, PT2.5YH 25 Kohm	C22, C24	100 pf NPO
R27	220 ohm	C23, C27, C28, C36	470 pf disc
R28, R48, R51	470 ohm	C31	470 uf/16V elec
R31	2.2 Meg	C33	68 pf NPO
R34	220 Kohm	C34	120 pf NPO
R35	Trimpot, PT2.5YH 1Kohm	C35	47 pf NPO
R36	6.8 Kohm	C14	12 pf NPO
R39	4.7 Kohm	C37	10 pf NPO
R45	1 Meg		
R47	1.5 Kohm		
R49	33 ohm		
R56	56 ohm		
Miscellaneous			
1 ea Cambion Blue Slug for L1			
1 ea 8-32 x 1 BHMS			
1 ea PC Board			
S1 DIP Switch, 10 position			
X1 4.864 MHz .01% crystal, HC49/U			
X2 10.240 MHz .01% crystal, HC49/U			
L1, L4, L5	#22 enamelled wire		
L2, L3, FB1	#73 Matl		
Ferrite Beads			

Build Your Own Low-Power Transmitters: Projects for the Electronics Experimenter

Semiconductors and ICs

D1	1N4007
D2	1N757A
D3	MV2107
Q1	MPF102
Q2, Q3, Q4	2N3563
Q5	MPS3866
IC1	LM1458N
IC2	LM1496N
IC3	74C00N
IC4	CD4040BE
IC5	LM7805 or LM340T-5
IC6	CA3420
IC7	MC145151-2
IC8	74F160ACP

A kit of parts consisting of complete documentation, a drilled and etched circuit board and all parts that mount on it, to build the MPX96, is available from the following supplier:

North Country Radio
P.O. Box 53, Wykagyl Station
New Rochelle, NY 10804-0053
E-mail: support@northcountryradio.com
Website: www.northcountryradio.com

Check their website for current prices and an order form. A suitable two-tone painted aluminum case, a hardware kit, and a matching eight-section collapsible whip antenna are also available from North Country Radio.

9. Microprocessor-Controlled FM Stereo Transmitter for 88-108 MHz

MPX2000 Theory of Operation

The MPX2000 is a full-featured FM stereo transmitter that offers LED frequency display, keypad frequency entry, a calibrated LED bar graph modulation meter with overmodulation and lock indicator LEDs, and full coverage of the 88–108 MHz band in 100-kHz steps. This unit is intended for use by hobbyists, experimenters, and others needing a low-power, short-range FM stereo transmitter. It is intended for music and/or speech. The left and right audio channels may be used independently to transmit two separate audio channels. This is useful for school and church use, when multilingual capability is desirable. The MPX2000 is also suitable for hobby Part 15 operation when a transmitter with digital frequency readout and keypad entry of frequency is desirable. The MPX2000 is fully crystal controlled, and the pilot and sub-carrier signals are also generated from a quartz crystal, ensuring stability and accuracy. A phase locked loop (PLL) system ensures frequency accuracy and crystal stability, and the use of a keypad and microprocessor permit ease of frequency entry without having to set jumpers or switches, and ensure that the programmed frequency is correctly produced. For a tutorial on FM stereo signal generation, please refer to Chapter 7.

MPX2000 Circuitry

We now discuss the MPX2000 circuitry. Refer to the schematic and the block diagram (Figures 9-1, 9-2, and 9-3) for this discussion. Audio input at line level (1 volt peak to peak at a 500–10,000 ohm impedance) is fed into jacks J5 and J6, which are left and right audio input channels, respectively. R1 through R4, with R7, make up an input network, and R7 is used to obtain an equal audio gain for both L (left) and R (right) channels. Q1 and C1, R5, R8, R10, and R14 make up the L audio preamp, with a gain of about 5 at 1000 Hz. Gain is shaped to produce a 75-microsecond pre-emphasis that is standard on FM receivers used in North America. The R channel is identical (Q2 and associated components). C5 and R16 feed amplified audio into a clipper consisting of diodes D7 and D8. These are biased by voltages from network R74, R75, R76, and R77. Audio is limited to 3 volts peak-to-peak by these diodes. The R channel uses the same circuitry. The purpose of the clipping is to prevent exceeding the maximum deviation (75 kHz) with excessive audio input. The clipper acts as an audio limiter. Next, both channels are fed into a two-pole active filter consisting of a quad op-amp IC1, a TLO84N, resistors R20, R22, R24, and R26, and capacitors C7 and C9 (left channel). The right channel has identical circuitry. The active filters cut off at 15,000 Hz and reduce aliasing distortion.

Build Your Own Low-Power Transmitters: Projects for the Electronics Experimenter

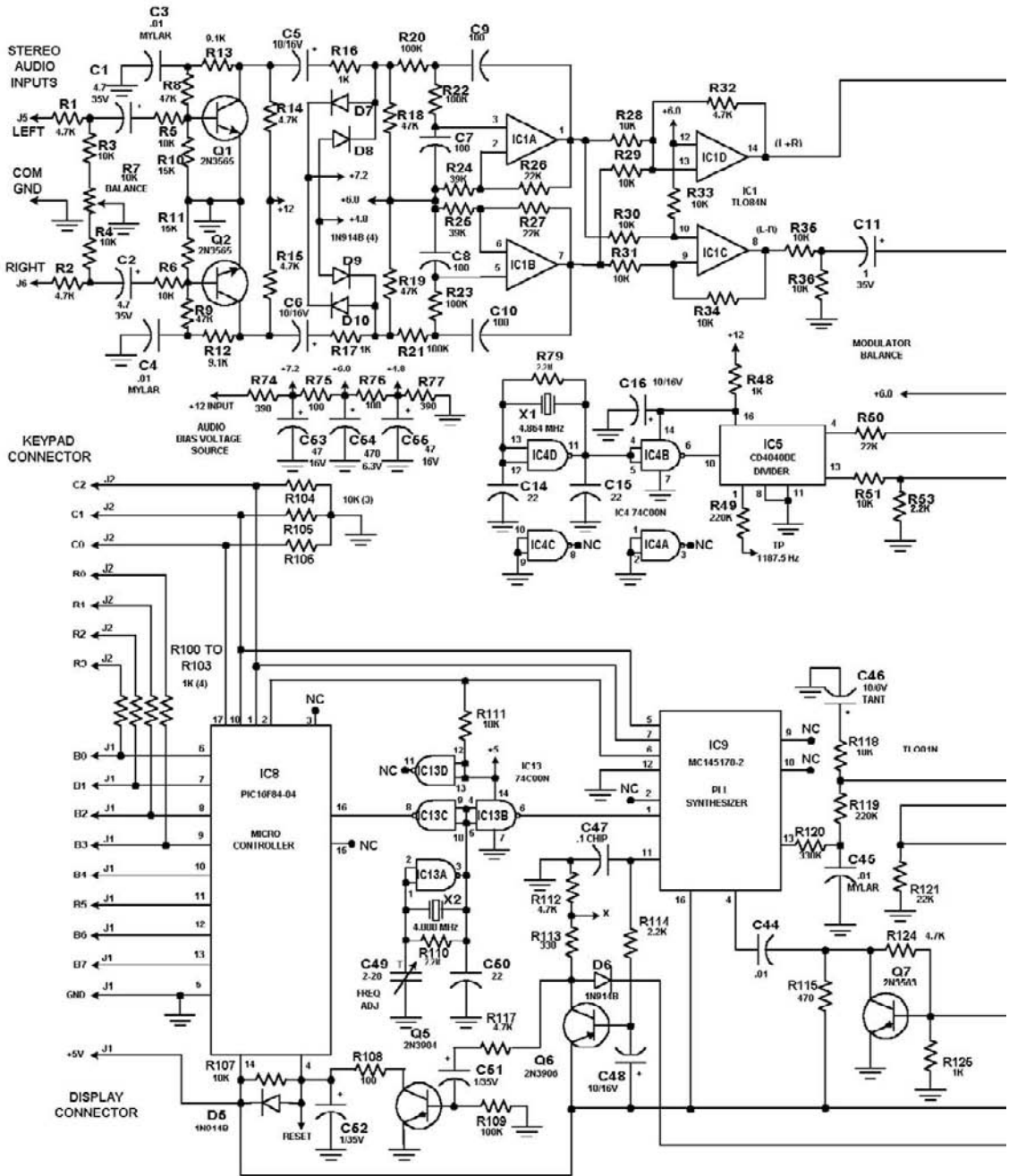
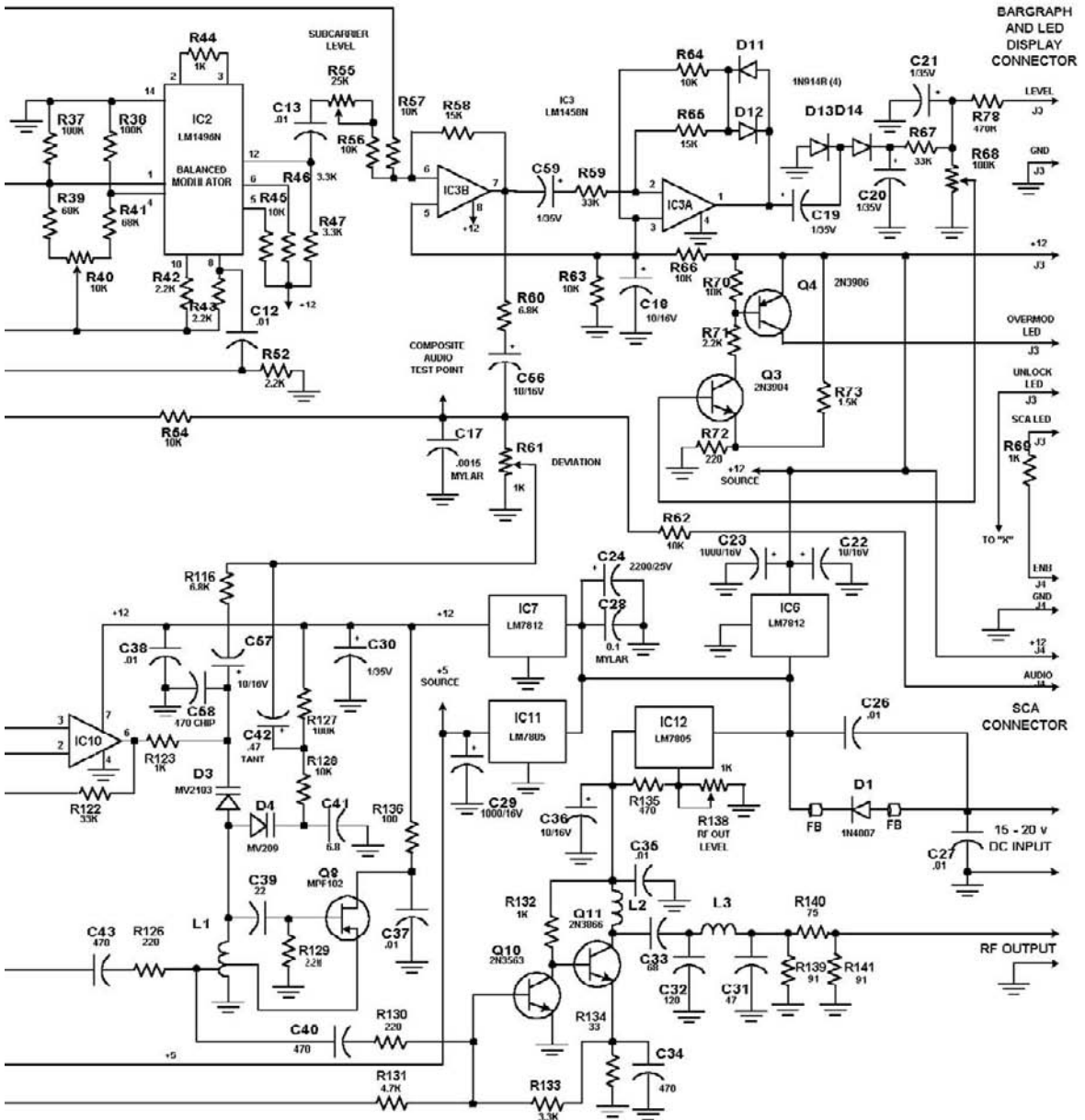

Figure 9-1
Schematic of the MPX2000 PLL Synthesized Low-Power FM Stereo Transmitter

Next, the audio signals are fed to the matrixing network using the other two sections of IC1. In one amplifier, the L and R channels are summed to produce the (L+R) signal and the (L-R) signal. Both of these signals are necessary for stereo generation. The (L+R) signal is the main monophonic channel that occupies the

Microprocessor-Controlled FM Stereo Transmitter for 88-108 MHz



band 20–15,000 Hz and is the signal received in a monophonic FM receiver. This allows stereo to be received as mono on an FM receiver without a stereo decoder, ensuring compatibility. The (L+R) signal is fed to summing amplifier IC3 via R57, where it is combined with two other signals, the (L–R) subcarrier signal and the

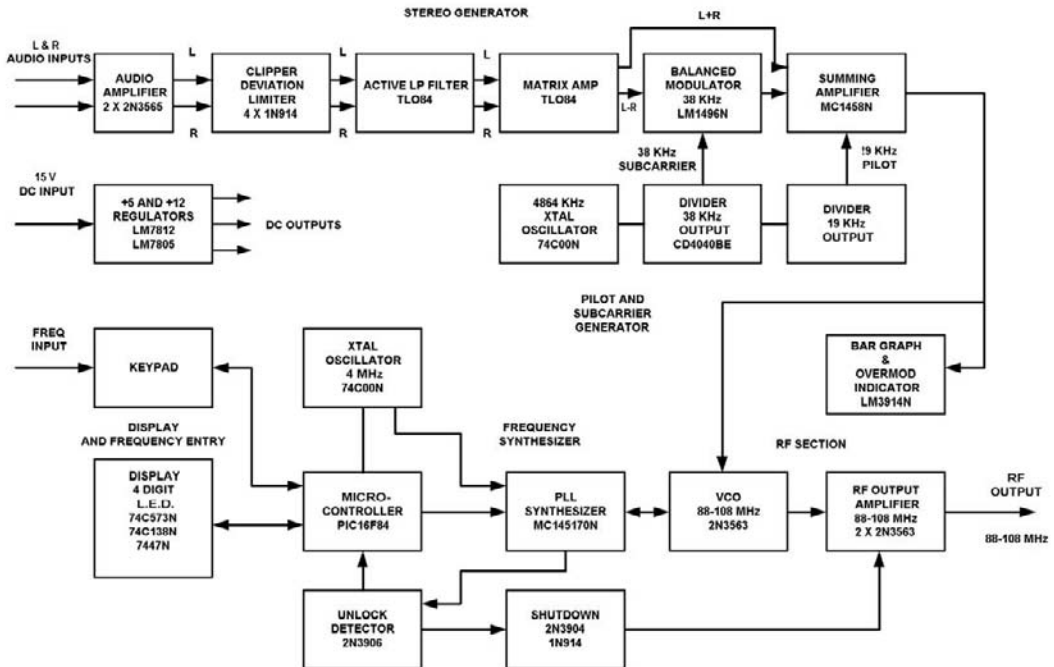

Figure 9-2
Block Diagram of the MPX2000 Low-Power FM Stereo Transmitter

19-kHz pilot. The (L–R) signal is the difference between the channels. This audio signal has the same frequency components as the main (L+R) signal and cannot be transmitted in the same channel as the (L+R). To solve this problem, the (L–R) signal is then modulated on a subcarrier at 38 kHz. The result is a double sideband AM suppressed carrier signal occupying a band from 23–53 kHz (38 kHz plus and minus up to 15 kHz). It is produced with a balanced modulator circuit IC2 and its associated components. (L–R) audio is fed into IC2 via R35, R36, and C11. Pins 1 and 4 of IC2 are fed DC bias via R37, R38, R39, and R41. R40 is used to balance the voltages at pins 1 and 4. Balance occurs when they are identical. R44 sets the circuit gain, and R42, R43, R45, R46, and R47 are biasing resistors for the input and output of IC2. The 38-kHz subcarrier is inputted at pin 8, and output appears at pin 12. In the absence of input audio, output is zero, and in practice R40 is adjusted to null the 38-kHz output with no (L–R) input. The 38-kHz signal is obtained from frequency divider IC5, a CD4040BE.

This IC is driven by a crystal oscillator/buffer at 4864 kHz, made up from two sections of a 74C00N NAND gate. C14, C15, and IC1 make up the oscillator circuit. In addition, a 19-kHz signal for the pilot carrier and a 1187.5-Hz signal useful for testing is obtained from the CD4040BE at pins 13 and 1, respectively. The 1187.5-Hz signal is taken off through a series resistor R49 and can be used to test the audio section, but is otherwise not used in the system. The subcarrier output is taken off through C13 and level control R55 and is fed to summing amplifier IC3. The output of IC3 is the sum of (L+R) and the (L–R) signals. It is fed to network C17–R61 via R60. In addition, the 19-kHz pilot signal from pin 13 IC5 is fed to this point via attenuator R51, R53, and R54, where it is reduced to a level 7–10 percent of the peak

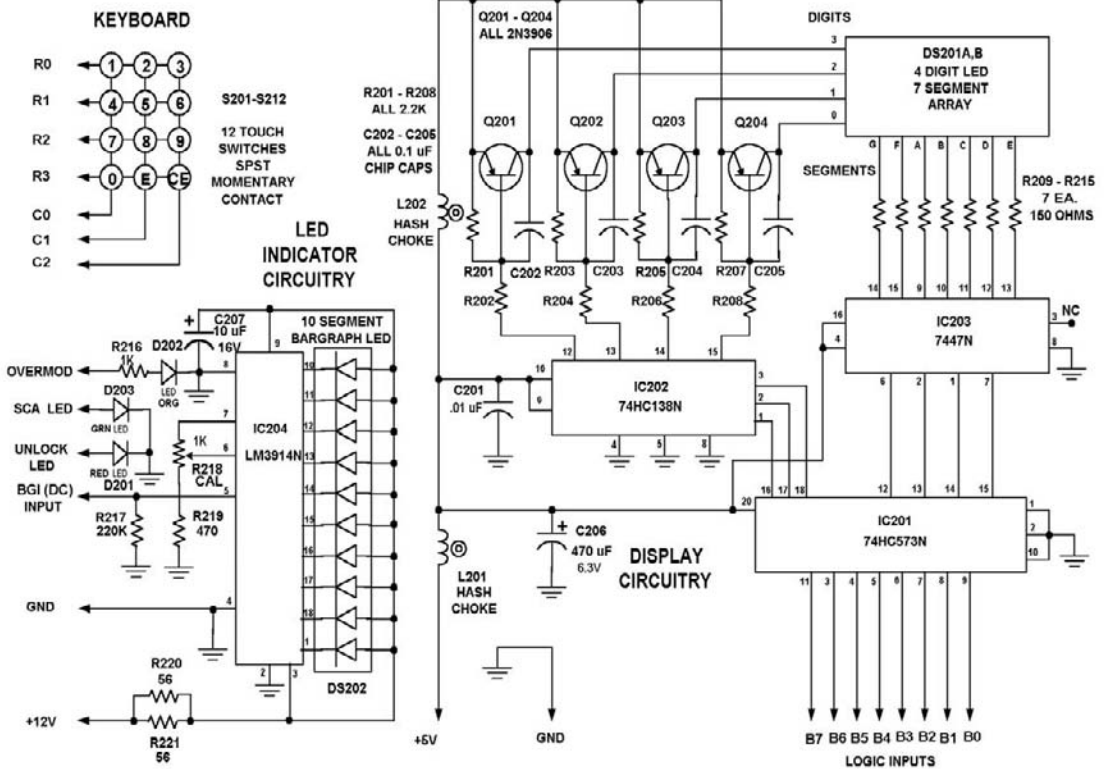

Figure 9-3
Schematic of the MPX2000 Display Board

audio level. This 19-kHz signal is used by the receiver to allow it to generate a 38-kHz subcarrier for recovery of the (L-R) audio component from the 38-kHz subcarrier signal received along with the main (L+R) signal. By adding and subtracting the (L+R) and (L-R) signals, the result is 2L and 2R, which are the individual L and R audio channels. The signal appearing across network R17-C61 is called the *base-band* or *composite stereo multiplex signal*. This signal is fed to the transmitter modulator. In order to ensure good audio quality on the transmitted signal, some audio-level monitoring is desirable. The MPX2000 uses a 10-segment bar graph level indicator, which consists of 10 LEDs mounted side by side to simulate a solid-state meter movement. In addition, another LED is provided, which lights when the peak audio level that would result in overmodulation is reached.

Audio from the summing amplifier is taken via R59, fed to an op-amp IC3 section, and then rectified to produce a DC level corresponding to the peak audio signal. R65 sets the gain of this stage to unity, and C19, D13, D14, and C20 make up a half-wave voltage doubler detector. D11, D12, and R64 are used to improve the linearity of the circuit at lower signal levels by increasing the gain of IC3 to permit low-level signals to overcome the 0.6-volt drop that is normally encountered in silicon diodes. The audio components are removed by R67 and C21 and applied across potentiometer R68. The DC voltage is fed to the bar graph level display via R78. A part of this voltage appearing from the wiper of R68 to ground is fed to the base of Q3. The emitter of Q3 is biased at 1.5 volts via R72 and R73. Potentiometer R68 is adjusted

so that when the audio signal is sufficient to light all 10 segments of the bar graph display, plus 10 percent extra, sufficient voltage (2.2 volts) is available at the base of Q3 to cause it to conduct. This turns on Q4 via R70 and R71, causing voltage to appear from the collector of Q4 to ground. This is fed to an LED on the display, lighting it, and indicating a condition of overmodulation. (The display panel is described separately in another part of this discussion.)

Next, an RF carrier that can be frequency modulated is required. It should be variable from 88–108 MHz to cover the entire FM broadcast band, and it must be stable within 10 kHz or better. The MPX2000 uses a PLL frequency synthesizer to generate all 200 channels at 100-kHz spacing, between 88.1 and 107.9 MHz, the standard FM broadcast band. The synthesizer is frequency modulated by applying audio to the voltage-controlled oscillator (VCO) in the synthesizer. This process is a contradiction in a sense because we want the VCO to be stable and yet be able to vary the frequency. With proper design, this goal can be accomplished without any serious compromises in transmitted audio quality or synthesizer performance. The VCO is the heart of the transmitter, and the synthesizer circuitry keeps it exactly on the desired transmit frequency. Free-running oscillators were used in the past for this application and are still used in low-end, low-cost FM transmitters.

It is difficult to keep these transmitters on frequency, and therefore they can be hard to use, especially with digitally tuned receivers. Stability of better than 100 kHz is difficult to come by with this approach; however, the use of frequency synthesis eliminates this problem. The VCO output must be buffered to eliminate frequency pulling caused by varying antenna loads, proximity effects, and so forth. In the MPX2000, FET Q8 is the VCO, and L1 and the combined capacitances of tuning varactor D4 and modulator varactor D3, together with inductor L1, make up the LC tuned circuit that determines the transmitter frequency. VCO FET Q8 is biased by R129 and R136. The drain of Q8 obtains DC from R136. Feedback is from a tap on L1 and is fed to the source of Q3 via C42. C40 and R130 couple some oscillator output from the VCO to buffer amplifier circuit Q9-Q10, which is made up of R132, R133, R134, and capacitors C34 and C35. L2, C33, C32, L3, and C31 make up an RF output network and harmonic filter for the buffer amplifier. R139, R140, and R141 ensure proper termination of this network and feed RF to the antenna. IC12, R135, R138, and IC12 make up a regulator circuit to feed regulated 5.6 volts to the buffer amplifier. In case of synthesizer malfunction, a DC level from the synthesizer IC is fed to R131 and cuts off the buffer, killing the RF output and reducing the possibility of transmitting outside the FM band.

The VCO is tuned by a voltage from the PLL chip phase/frequency detector. The PLL chip (IC9) is a Motorola MC145170-2. Inside this chip, a sample of the VCO signal is compared with a reference frequency; if they are not in phase and frequency agreement, an error voltage is generated. This technique is used to change the tuning voltage on the VCO, such as to achieve frequency and phase agreement (lock). R126 and C43 feed a sample of the VCO signal to amplifier Q7. Collector resistor R115 biases Q7, and the signal to drive IC9 appears across it. C44 couples this signal to IC9. IC13 generates a clock signal at 4.000 MHz via XTAL1, trimmer C49, and C50. C49 is used to adjust the frequency to exactly 4.000 MHz. The 4.000-MHz signal is used both as a reference signal for the PLL synthesizer and for microcontroller IC8. Two sections of IC13 are used as buffers to provide this signal to IC8 and IC9.

The synthesizer frequency depends on several data words programmed into IC9. The needed data words are provided by IC8, a PIC16F84 microcontroller. This microcontroller is programmed with the necessary software to program IC9 and to manage other tasks, such as the control of the frequency display and scanning the

keypad for frequency entry. Other functions necessary are system shutdown in case of malfunction, rejection of out-of-band frequency entries, and remembering and setting previously used frequency on powering up of the transmitter. When a valid frequency is entered, a voltage appears at the phase detector output pin (13) of IC9. This voltage is fed to network R118, R119, R120, and C46. This network determines some of the loop characteristics of the synthesizer. The output of this network is fed to op-amp IC10 and then to tuning varactor D4. At lockup, this will be a steady DC voltage, varying from 3–4 volts at the low end to as much as 10 volts at the high end of the FM band.

In case of loss of lock, IC9 produces pulses at pin 11. These pulses are integrated by R114 and C48. The DC voltage turns on Q6, placing 5 volts across R113 and R112, and D6. This sends a voltage to the unlock indicator LED D201 and cuts off the RF buffer via D6 and R131. In addition, the rising voltage is coupled to the base of Q5 via R142 and C51, turning on Q5 momentarily. This step causes Q5 to conduct, resetting the microcontroller via R108 and resetting network D5-R107. Capacitive coupling is used to couple signal to Q5 so as not to permanently cause a reset of the microcontroller, otherwise a lockup condition will occur. Normally, this resetting process is a sufficient cure, if the problem is incorrect frequency entry or a “glitch” because resetting the microcontroller reprograms IC9 with the correct data. During this process, the RF output is disabled.

Modulation is achieved by applying baseband audio from R61-C17 to both varactors D3 and D4. This allows better modulation and fewer compromises than if audio were applied to the tuning varactor D3 alone. IC7 provides a regulated 12 volts to the PLL and helps filter out any noise disturbances appearing on the power supply.

The audio section is supplied with 12 volts regulated from IC6, and IC11 supplies 5 volts to the microcontroller, display logic, and PLL synthesizer IC. The use of separate regulators for audio and digital functions helps reduce circuit noise. DC input to the MPX2000 should be between 15 and 20 volts to allow sufficient headroom for the regulators, yet keeping dissipation within reasonable limits. (This can be reduced a few volts with low dropout regulators.) Care must be taken to use a wall transformer that is adequately filtered so that the input voltage waveform to the MPX2000 never gets below 15 volts. With less than 15 volts input, DC voltage is insufficient to allow full VCO control voltage swing, and some of the 88–108 MHz tuning range will be lost at the high-frequency end. Also, adequate RF decoupling of the DC supply is needed to reduce the possibility of RF-induced ground hum on the transmitted signal. RF chokes may be needed in both power leads in certain situations.

Next, the display board circuitry is discussed (Figure 9-3). This board contains a 4-by-3 matrix of touch switches, a four-digit LED multiplexed display, and the bar graph LED and its associated driver, an LM3914 (IC204). Additionally, three other LEDs that serve as overmodulation (D202), PLL unlock (D201), and SCA subcarrier ON (D203) are also included on this board. The keyboard is polled periodically by the microcontroller for a switch closure by applying a logic level to a row and looking to see if this level appears on one of the three columns. Each switch has a unique row and column location, and the switches are scanned sequentially, 1 through 10 (10 is represented by 0), and two other keys, E (enter) and CE (clear entry). The desired frequency is entered, with the most significant digit first.

Because we have four digits, for frequencies below 100.0 MHz, the most significant digit is 0. This 0 does not really have to be entered, although it is recommended to do so. This eliminates possible “glitches” or entry errors and fully clears the keyboard memory. When the first entry is made, two zeros appear on the display to the left of the entered digit. The leftmost is blanked on leading zeroes. For example, 99.5

MHz is displayed as 995 instead of 0995, but no changes are made in the PLL programming or the transmit frequency until the enter (E) key is pressed. The digits appear on the display as they are entered and shift right to left. Four digits are to be entered, and if more than four digits are entered, the leftmost is shifted out. After the display shows the desired frequency, the enter key is pressed, and if it is a valid (legal FM channel) entry, the display will retain it, the PLL will shift the transmitter frequency to it, and it will also be stored in memory. This frequency will come up when the MPX2000 is powered up the next time. If an illegal entry (lower than 88.1 or higher than 107.9) is made, the microcontroller will reject it and simply revert to and display the current frequency. If an error is made during entry, the CE key can be pressed, and the current frequency will once again appear. When the MPX2000 is powered down, the current frequency is retained in memory and reappears on the next power up. No memory backup battery is needed for the microcontroller.

The display section is a conventional four-digit multiplexed display using four 7-segment common anode LED digits, driven by a 7447N TTL driver IC. R209 to R215 are current limiting resistors for the individual segments. No decimal point is used in this display. There are eight logic inputs from the microcontroller, which are feed a 74HC573N eight-bit latch IC201. The digit data is latched into the 74HC573N by a strobe pulse from the microcontroller at the appropriate time, and this data contains the binary value of the particular digit and its position on the display. The digit select information is decoded by a 74HC138N decoder, and its output turns on one of four 2N3906 switching transistors Q201–Q204 via bias resistors R201–R208. L201, C206, and L202 are noise suppression chokes to reduce switching noise. The display segments are operated at 20 mA each, and if an 8 digit is shown, 140 mA must be switched by the 2N3906 associated with that digit. Chip capacitors C202–C205 slow down switching speeds to further reduce noise spikes. Although an LED display can be noisy and consumes a lot of current, it is much brighter, has more eye appeal, and is easier to read than an LCD. LED readouts need no illumination. The display is shut down by the microcontroller about 15 seconds after the last keypad press, cutting off the display multiplexing and leaving a few segments lit on the least significant digit to serve as a power-on indicator. This approach eliminates residual switching noise generation and conserves current. The display can be awakened by pressing the 0 key to check the current frequency setting. It will stay on for 15 seconds and go back to sleep.

The display and multiplexing could have been handled directly by the microcontroller without the three ICs, but the software overhead would be larger and the current of the LED display would be too much to be directly handled. This approach was tried, but the display was too dim, performance of the microcontroller was a little slow, and some additional “glue” circuitry was needed because of the limited number of pins that were available on the PIC16F84. In cases such as this one, a hardware versus software tradeoff has to be made. The hardware multiplexing approach was used here because it gave the best results. A larger microcontroller could also have been employed, but this option was not investigated.

The bar graph display is conventional and uses an LM3914 linear bar graph driver (IC204). DC input from the main board is applied to pin 5 of IC204, and the sensitivity is determined by the setting of R218. Approximately 0.8 volts DC is needed to light all 10 segments of LED display DS202. R218 is set so that 10 segments light when the main board audio system is producing full audio level just short of limiting. This represents 100 percent modulation. R220 and R221 limit power dissipation in IC204, and C207 bypasses the Vcc line to the display. D201 is fed from the unlock detector on the main board and, when illuminated, indicates that the PLL is

unlocked. D202 is powered from the main board and is illuminated when audio clipping occurs, indicating overmodulation. D203 is used to indicate that the optional SCA audio subcarrier system is activated.

The MPX2000, when once programmed to a desired frequency, operates without the display board because its functions are mainly supervisory. The board may be disconnected during operation with no effect on the transmitted FM signal; however, it is needed for reprogramming of frequency.

Overall power requirements of the MPX2000 are 15–20 volts DC at 350 mA. The display consumes much of this current. If the display is asleep, this is about 160 mA. When the display is disconnected from the main board, current consumption drops to 125 mA. Operation below 15 volts is not recommended unless low-dropout regulators (LM2930, etc.) are substituted for the LM7812s used here. Operation above 20 volts may cause overheating of the 5-volt and 12-volt regulator ICs. Heatsinks should be fitted to these ICs if operation over 20 volts is expected. The DC input is polarity protected by D1, and accidental polarity reversal will do no harm; the MPX2000 will simply not operate and draw no current until the supply polarity is corrected.

Construction of the MPX2000

PC Board Assembly

The MPX2000 PC boards (see Figures 9-4 through 9-7), while having nothing very critical or difficult to handle by someone with a little PC board assembly experience, require a certain assembly sequence in order to avoid mistakes that lead to elusive problems. In particular, several through-hole connections (vias) are required to connect traces on both sides of the board.

Plated-through boards are great for mass production of PC boards. They reduce assembly cost and facilitate soldering; however, the use of homemade boards generally precludes plated-through holes. If you must remove a component from a plated-through board, you will have a difficult time and will probably ruin the component and the PC board as well, unless you have a specialized workstation with a vacuum desoldering setup. It is normal and expected that you will make a few assembly errors in constructing any new project because you are doing the task for the first time and you are inexperienced with the assembly. With a plated-through board, you may need a replacement part or PC board if you make an error. Therefore, we do not recommend the use of plated-through PC boards in this project.

The boards are best assembled and tested circuit by circuit. First, the main board can be prepared, jumper vias installed, and a few parts for the power distribution circuitry assembled. Then, the board should be powered up and checks made for various voltages. A power supply of 15–20 volts DC and a DC voltmeter are needed for these tests—a VOM or a DVM will do. Next, the audio (MPX) circuitry can be assembled and tested. If it works, the display board should be assembled next. Then the microcontroller section is installed on the main board, which can be tested together with the display board if desired. After this step is done, the RF circuitry can be assembled and the entire MPX2000 can be checked out. At this time, the project is operational. No critical adjustments are needed, and it should work the first time with the default settings given in the assembly procedure that follows, assuming that you have made no mistakes. Although it is possible to simply “stuff” the PC boards and wait until after completion of assembly for testing, this is really not recommended unless you are *very* experienced.

Build Your Own Low-Power Transmitters: Projects for the Electronics Experimenter

Figure 9-4
Component Side
Parts Layout of
the MPX2000
Main PC Board

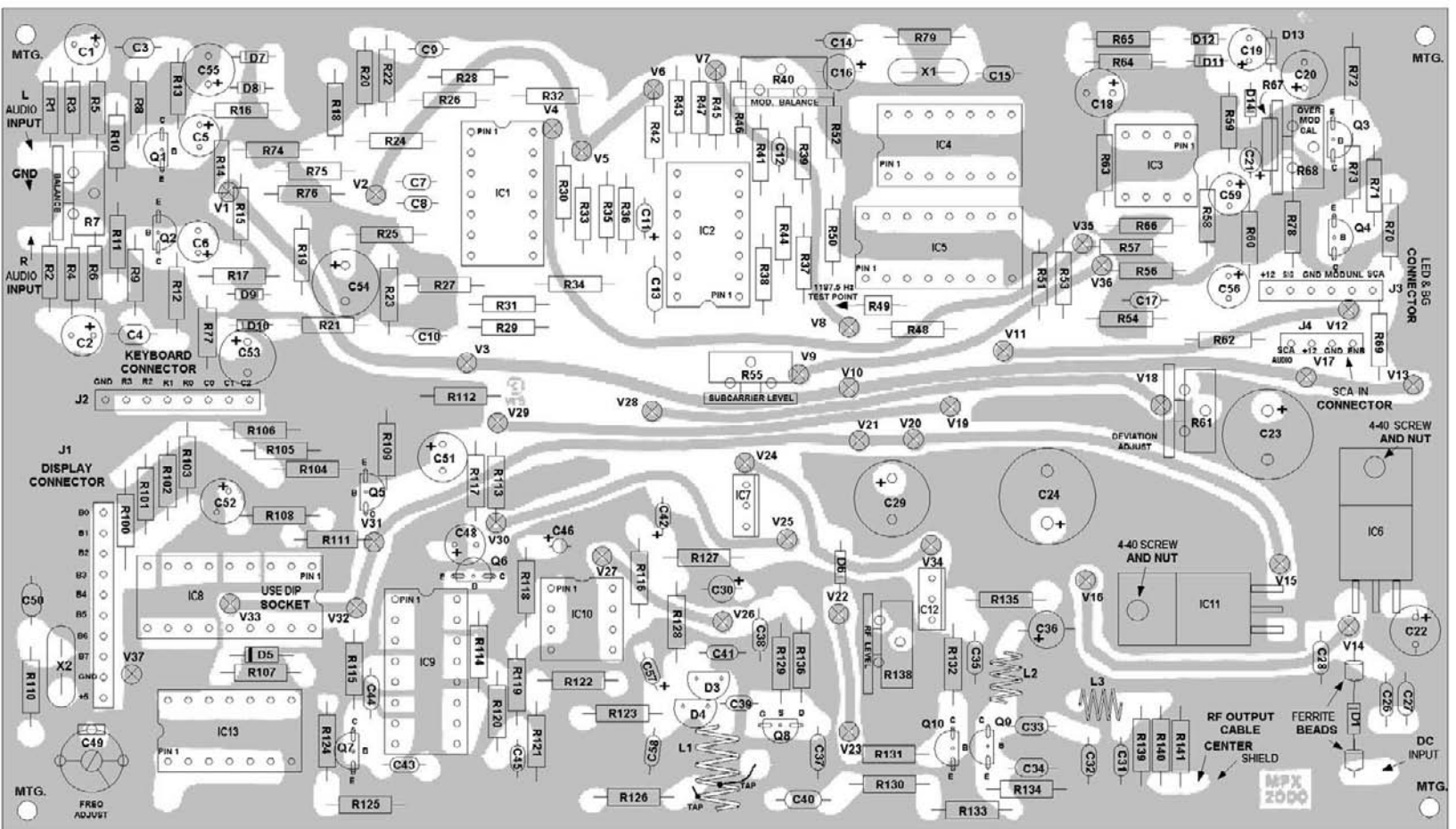

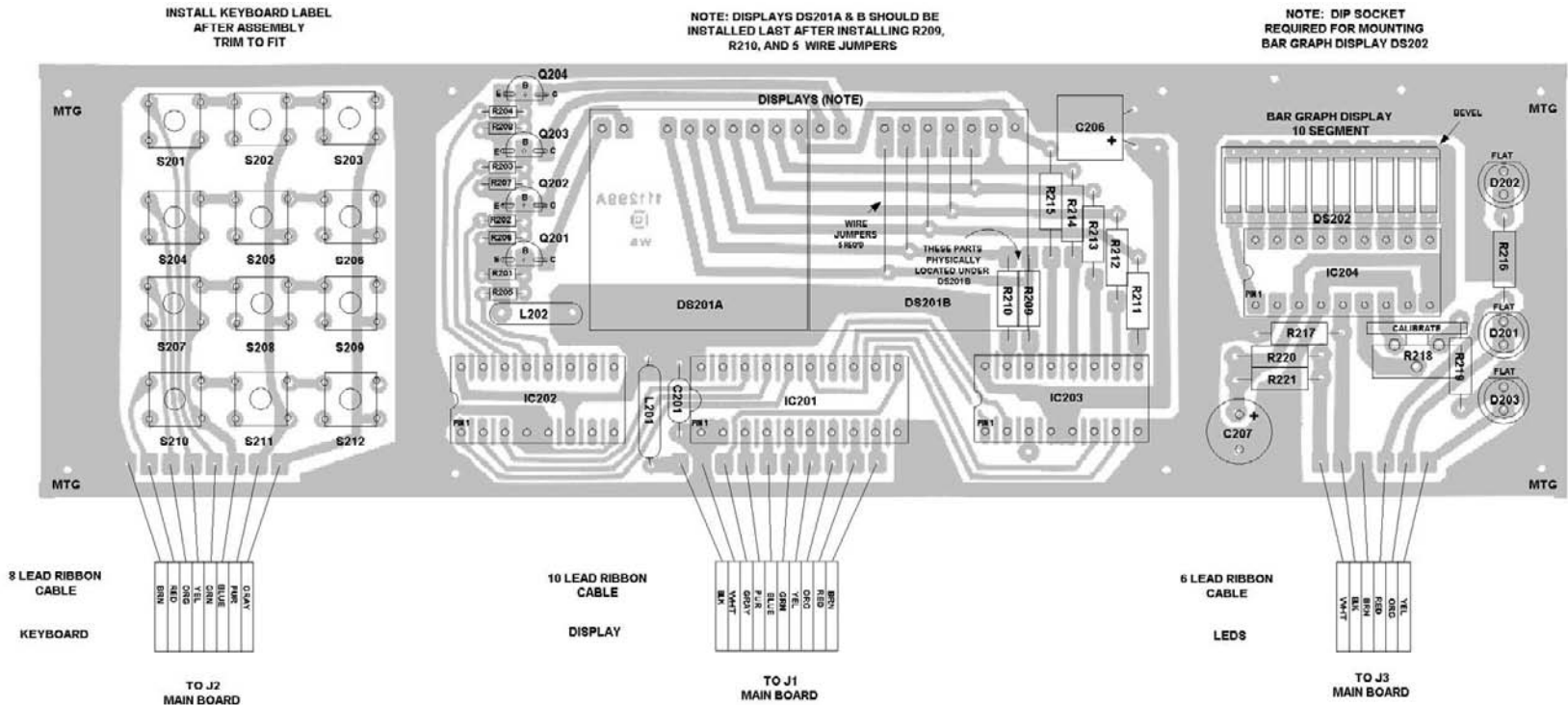

Figure 9-5A
Component Side
Parts Layout of the
MPX2000 Display
Board

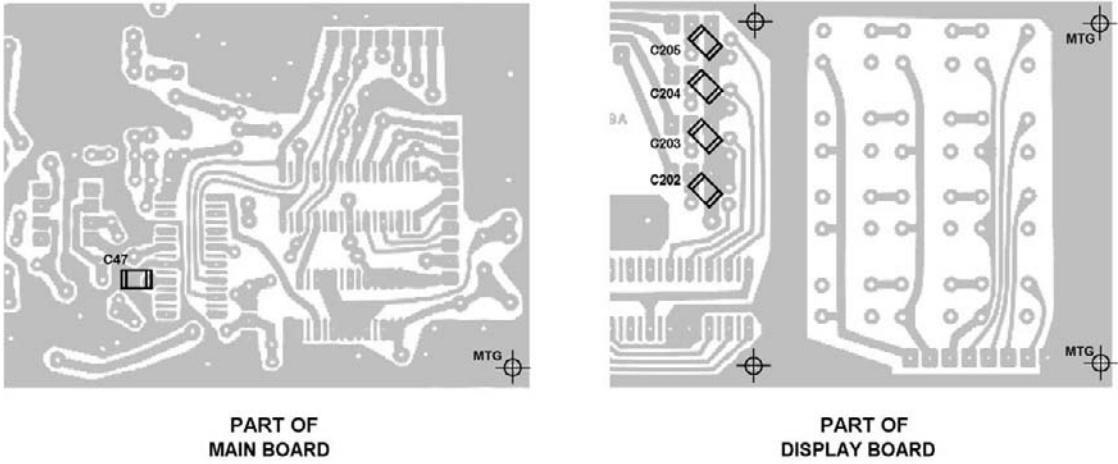

Figure 9-5B
Chip Capacitor Placements Main and Display Boards Foil Sides

Figure 9-6
Solder Side of the
Main Board of the
MPX2000

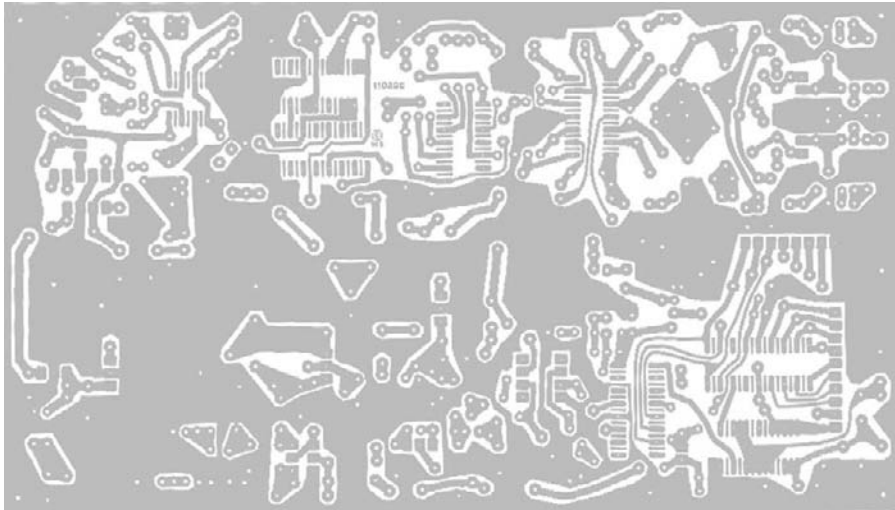
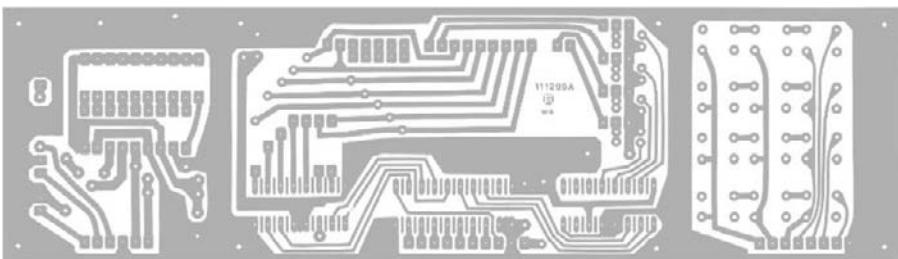

Figure 9-7
Solder Side of the
Display Board of
the MPX2000



First, install all vias and any parts that connect to them, the regulators and DC power supply filtering, and bypassing components. Check your work and make sure that all connections are soldered. Connect +15 to +20 volts DC to D1 (positive lead) and the negative lead to ground on the PC board. Check for the voltages on the following list. (All voltages assume that the regulator ICs supply an exact 5 or 12 volts. Because they have 5 percent tolerance, which is acceptable for this application, remember to allow for this variance if your voltages are a little low or high because they depend on exact regulator voltage.) Consult the parts placement diagram (Figure 9-4) for the physical location of the test points as needed.

Jct. C26, C27, D1 (Input): +15 to +20 VDC

Jct. C28, IC6, IC11, IC12, IC7: +14.4 to +19.4 VDC

V31: +5.0 \pm 5% VDC

V1: +12.0 \pm 5% VDC

V6: +6.0 VDC

Wiper R40: +6.0 VDC

Jct. R74, R75, C53: +7.25 VDC

Jct. R76, R77, C55: +4.75 VDC

Jct. IC7, C30: +12.0 VDC

Jct. IC12, C36: +5 to more than +12.0 VDC (Should vary with R138. Set for +5.6.)

Next, inspect all voltage points (see parts placement diagram) to make sure they are soldered, and contact the traces on both sides of the board. These tests confirm all work so far and ensure that all sections of the PC board will get DC power and that all signal traces are intact. Then install the audio and MPX generator circuit components.

Audio and MPX Generator Checkout

Apply +15 to +20 volts as before to the DC input and check for the voltages on the following list. (It is assumed that all voltages that you obtained were as specified in step 1 checkout of the PC board, before the audio components were installed. Using 10 percent tolerance is acceptable.) Preset all potentiometers to the center of rotation, except R138.

Collector Q1 and Q2: +3.6 VDC

Pin 4 IC1: +12.0 VDC

Pins 1, 7, 8, 14 IC1: +6.0 VDC

Pins 1 and 4 IC2: +3.1 VDC, varying with R40

Pins 2 and 3 IC2: +2.4 VDC

Pins 8 and 10 IC2: +5.9 VDC

Pins 6 and 12 IC2: +8.5 VDC

Pin 5 IC2: +1.2 VDC

Pins 1, 7, 8, 14 IC3: +6.0 VDC

Collector Q4: 0 VDC

Collector Q3: +12.0 VDC

Emitter Q3: +1.5 VDC

Jct. R67, R68, R78, C21: 0 to +0.2 VDC

Pin 16 IC5: +7.5 to +9.0 VDC

Voltage Settings and Display Assembly

Next, set R40 so that the voltage between pins 1 and 4 of IC2 is zero. Make this adjustment with the most sensitive scale on your meter, to as low as 1 mV if possible. If you have or can borrow a scope and audio generator, you can apply a 1-volt peak-to-peak audio signal to the L and R inputs and trace the signals through the circuitry. This technique is excellent for uncovering any errors before you proceed further and ensures that all is well so far. You can also use a source of stereo audio, such as a CD player, cassette player, or stereo receiver, and use an audio amplifier and speaker to trace the signals through the circuitry. You will not be able to hear the pilot and the subcarrier signals (unless you are a cat or a dog) because they are above the audible range of frequencies. Refer to the waveform diagram for audio waveforms. Adjust R7, R40, and R55 as needed to get these waveforms. If you cannot do this procedure because of a lack of test equipment, then leave all potentiometer adjustments where they are. If the DC voltages were all correct and your assembly is error free, all should be okay so far.

The display board consists of three separate circuits: the keypad, LED display circuitry, and the bar graph metering and status LEDs (see Figure 9-8). These circuits should be tested in conjunction with the microprocessor section, but some initial tests can be made on this board without it. This board is single sided.

Insert the 12 touch switches that make up the keypad. If you like, you can check out the keypad with an ohmmeter to see if continuity exists between a row and column when the corresponding switch is pressed.

Next, assemble the display section (center of display board). Make sure that you first install the jumpers that are located below where the LED displays are later installed. You can use low-profile DIP sockets here if you wish to avoid soldering the ICs directly onto the PC board. Now install LED assembly DS201. This consists of two identical two-digit subassemblies. Next, fabricate and install hash chokes L201 and L202 (see Figure 9-9 for details). These are not critical regarding inductance, and 15–20 turns are sufficient. Install a 20-pin socket where DS202 is to be located. This socket *must* be used so the top of DS202 is at the same height as DS201. Then plug DS202 into the socket, making sure that the rounded corner or pin 1 indicator faces the corner of the PC board. No harm will be done if DS202 is inserted backwards, but DS202 will fail to light. Next install IC204, the LM3914N bar graph

Figure 9-8
Front Panel
Assembly Details
of the MPX2000

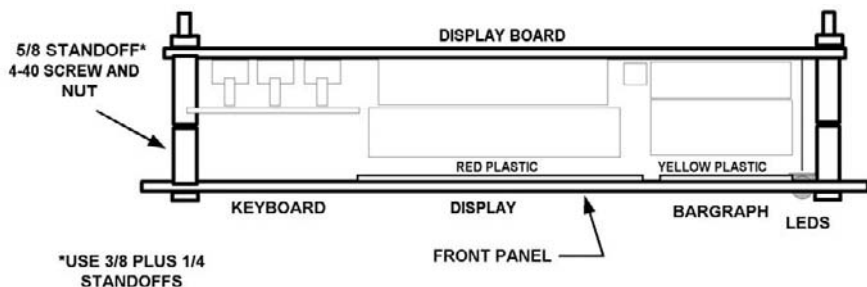

driver chip. You can use a DIP socket if you wish, as before. Install LEDs D201, D202, and D203, making sure to observe polarity. Also make sure that the tops of these LEDs are the same height as DS201 and DS202. This step completes the display board assembly.

Microcontroller and Logic

First, install 10-pin header (J1) and 8-pin header (J2) as shown in the display board parts placement drawing. Make sure V32 and V33 are well soldered because you will not be able to access them after this step. Next, apply DC power to the board as before and check for +5 volts on the J1 pin shown. Remove DC power and allow a minute for the capacitors to discharge. Next, install the programmed PIC16F84 microcontroller and all related parts. The microcontroller must be programmed with the appropriate software in order to operate properly. If you are building this project from scratch, you will have to do this step for the project to work. We refer you to the books and data sheets published by Microchip Corporation regarding how programming is done. You can write your own software or, if you prefer, a preprogrammed microcontroller can be purchased from the source mentioned at the end of this article.

Make sure to install an 18-pin socket at IC8. This is required to allow easy removal of IC8 so that future changes can be made to the internal operating software if needed. You may also install a DIP socket for IC13, but this step is optional. The display board can be connected to the main board using ribbon lead cable of the kind used in PC internal cabling, which is recommended. You can use Molex or similar connectors with 0.100-inch spacing to plug directly into the headers on the main board; however, installing these connectors generally requires a special crimp tool. Alternately, you can use solder-type connectors or “press-on” types. Check out a computer parts catalog for suitable connectors. Connectors are not absolutely needed, although they do make testing easier; however, installing them takes time and may not be worth the effort. Once the MPX2000 is assembled and packaged in a case, these leads do not usually have to be disconnected again. You can check out the microcontroller section now, but it requires wiring it to the display board and disconnecting it again. If the wiring is correct, little can go wrong here.

PLL and RF Section

This section is the last to be assembled, and when completed, the MPX2000 PC boards will be ready for final testing and installation in a case of your choosing. First, install all resistors, then install capacitors, followed by transistors Q5 through Q10, and all diodes. Next, install the remaining ICs, IC9 and IC10. Again, you can use low-profile DIP sockets for IC9 and IC10 if you wish. Make sure to observe correct IC orientation.

The final step is the fabrication of L1, L2, and L3 (see Figure 9-9 for coil details). L1 is five turns of #18 tinned wire wound around a 1/4-inch mandrel. L1 is installed in the PC board with the turns spaced evenly so the coil fits the PC board. A tap consisting of a short wire lead soldered to the appropriate point on the PC board is then connected to the first turn of the coil as shown in Figure 9-9. L2 and L3 are made from four turns of #22 bare tinned wire wound using the threads of an 8-32 screw as a mandrel. L2 and L3 will look like small springs when made; the screw controls the dimensions, so you cannot go wrong. Shape the leads as shown in Figure 9-9.

Figure 9-9
MPX2000 Coil
Winding Informa-
tion

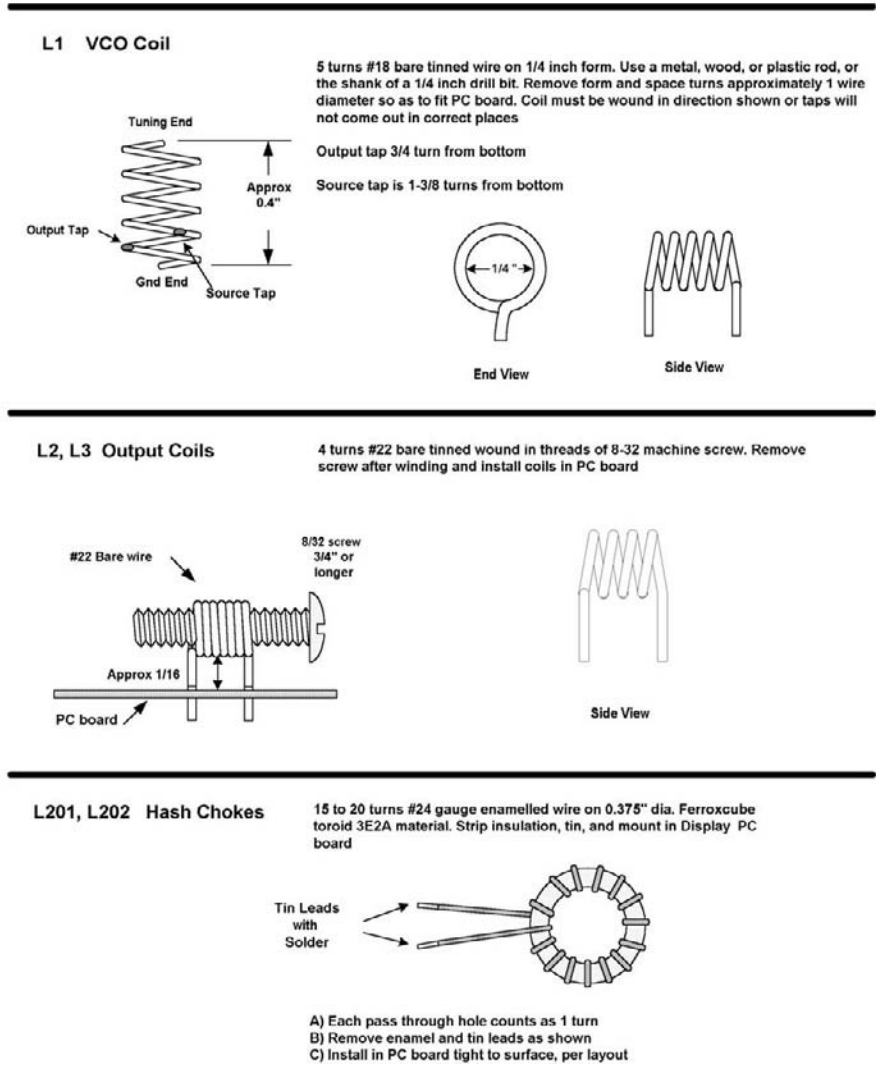

Remove the screw and install the coils in the PC board. Make sure no adjacent turns short together on L1, L2, or L3. Next, check over all work done so far for any errors. You are then ready for final testing. The display board must be connected to the main board for final testing.

After installing all components, make sure that the ICs, diodes, and electrolytic capacitors are correctly oriented. Power up the board as before and note the following: Bar graph display DS202 should momentarily flicker and then go out; this is normal and a good sign that things are working fine. The frequency display should light and show either a valid FM station frequency or three zeroes. The left-most (MSB) digit is zero blanked and will not display a zero. Next, examine the keyboard layout in the display board parts placement diagram; it is fairly standard. Now, enter an 8. The right digit should show this entry. Enter another 8, and now the two right digits should show "88." Enter a 1. The display should show "881." Now press the enter key. The display should still show "881." Now remove DC power, and after

about 10 seconds, reconnect power. The display should light up “881.” Now try entering each digit 1 to 9 in sequence. The newly entered digit should appear on the right and move left as new digits are entered; the fourth digit will disappear off the left side as new digits are entered. Now press the enter key, and unless the display is showing a frequency between 881 and 1079, the display will revert to 881 or whatever valid frequency it previously showed.

To reject an entry, press the clear entry key, and the display will show the previous valid frequency. Try entering a few valid FM frequencies, each time pressing the enter key afterward. Removing power and repowering should result in retention of the frequency in memory. If the frequency displayed differs, try reentering all four digits (i.e., 0995 for 99.5 MHz instead of 995). The leading 0 is needed and does not show. A 1 is sometimes retained in memory when a frequency of 100 MHz or more was previously entered. Entering a new frequency less than 100 MHz may not erase the fourth digit, and the 1 will be retained, confusing the microcontroller. This is not a fault but rather a result of suppressing the leading 1 for purely aesthetic and appearance reasons, making the operator forget that it is still really there. It is best to enter 0883 rather than 883, for example, especially if the previous frequency was 100 MHz or higher. When you are done, enter “0981” because this frequency is needed for later testing. Leave this frequency in memory. If everything works as specified, you can assume that the microcontroller and display circuit are correct.

Next, apply an audio signal of about 1-volt peak-to-peak to the L input. The bargraph indicator should show several lit segments. Adjust R218 on the display board so all 10 segments light. Then increase the signal about 10 percent and adjust the pot R68 on the main board so that overmodulation LED D202 on the display board (to the right of DS202) just lights. Reduce audio drive and D202 should extinguish, with DS202 showing fewer segments lit as the audio input is decreased. This step checks out the metering circuit. Now repeat that step with audio connected to the R input. No difference should be noted, and no readjustment should be needed.

Final Test and Setup

You will need a VOM or DVM, an FM stereo receiver of some kind, and a source of line-level stereo audio. The MPX2000 is designed so that 1-volt peak-to-peak (0.316 volts RMS sine wave) at the input produces the required deviation, and the audio input level should not exceed this figure. The input impedance is approximately 10k ohms. Power up the board and check for the following voltages:

- Pin 16 IC9: +5 VDC
- Pin 7 IC10: +12 VDC
- Pin 6 IC10: +3 to +12 VDC
- Collector Q5: +5 VDC
- Collector Q7: +1.5 to +3.8 VDC
- Center pin D4: same as pin 6 IC10
- Jet. D2, D3, R128: +12 VDC
- Collector Q8: +12 VDC
- Base Q8: + 5 to 7 VDC
- Emitter Q8: + 4.5 to + 6.5 VDC
- Collector Q10: +1.4 VDC

Emitter Q9: +0.7 VDC

Collector Q9: +5.6 VDC (adjust R138 as required)

After this test, remove power from the MPX2000. If any of the voltages were incorrect, the reason should be determined before proceeding further. If these voltages check out, you may proceed. Power up the MPX2000. Frequency 98.1 should appear in the display; if not, enter this frequency as described previously. On power up, bar graph display DS202 and unlock LED D201 should flicker and go out. Measure the voltage at TP1, pin 6 IC10. It should be more than 3 and less than 11 volts. Now enter a frequency of 107.9 MHz. When the enter button is pressed, D201 should flicker and go out, indicating lockup of the PLL. The unlock LED may take several seconds to extinguish. This delay is normal because of the long loop time constants used. If DS201 stays lit, check the voltage at TP1; it may be 11 volts or higher.

Spread the turns of L1 until this voltage drops below 10 volts and D201 goes out. Next, program in a frequency of 88.1 MHz. Check to see if D201 flickers and goes out. Measure the voltage at TP1; it will be around 3–3.5 volts. If D201 is still lit, compress the turns of L1 slightly until the voltage rises slightly and D201 goes out. Recheck at 107.9 MHz and 88.1 MHz until lock is obtained at both frequencies—indicated by D201 extinguishing. It is normal for D201 to flicker slightly when changing frequency. If you are unable to get both 88.1 and 107.9 to lock up with one setting of L1, check to make sure you have at least 12 volts at the output of regulator IC7. If not, you can replace it or add a diode in the common leg of IC7 to raise the voltage slightly.

Once the PLL is adjusted, set up an FM receiver on 98.1 MHz or somewhere near this if 98.1 MHz is busy in your area. Enter this frequency into the MPX2000. LED201 should extinguish after a few seconds, and you should hear a carrier in the receiver, as evidenced by the quieting of the receiver. Momentarily power down the MPX2000 to confirm that the carrier is coming from it and not from somewhere else. Restore power, and the carrier should reappear in a few seconds when D201 extinguishes. Next, connect audio to the L and R inputs. The bar graph display should indicate something, and you should hear the audio in the FM receiver. The receiver's stereo indicator should be on, and the audio should sound like any other FM station. Make sure you do not apply excess audio because this causes distortion and degrades stereo separation. Adjust R55 for best separation. If you have access to an audio generator and scope, you can get an exact alignment by adjusting for the waveforms shown in the waveform diagram. Adjust the input audio level for best sound in the receiver without distortion and clipping. With this audio input level, set R218 on the display board so that the LED bar graph shows all 10 segments lit on the loudest audio peaks. Slightly increase input audio and adjust R68 so that the over-modulation LED D202 just flashes. Then back off the audio input level so that it barely flashes on the loudest audio peaks. This step sets the proper audio drive level.

Packaging

The MPX2000 may be packaged in any suitable metal or plastic case (see Figures 9-8, 9-10, and 9-11). Remember that this audio device generates RF signals, so the use of shielded cables for audio input and RF output is recommended. Keep the display board as far as possible from audio lines and the main board because it does

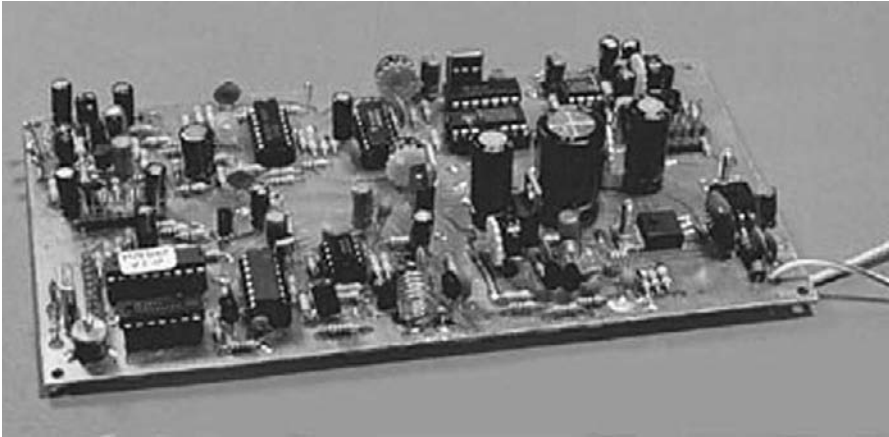

Figure 9-10
Photo of the Main
Board of the
MPX2000



Figure 9-11
Front Panel View
of the Completed
MPX2000

generate some switching noise, which could appear as buzz or hum on the transmitted signal until the display goes to sleep. Once programmed, the MPX2000 will operate without the keyboard and LED frequency display as long as the frequency is not changed. We recommend that accessibility to the keyboard be limited to keep curious individuals from playing with the MPX2000 and inadvertently changing frequency. This can be done with a removable panel or cover over the display.

The LEDs indicating lock and modulation should be kept visible at all times to signal improper operation. A good RF ground and antenna system is essential in reducing RF ground-induced hum, which is a problem with low-power FM transmitters. Simply using a wall transformer and a whip antenna plugged into the RF output jack might not provide adequate RF grounding. To check if hum is RF induced, power the MPX2000 from a battery. If this cures the hum, the problem is either a poorly filtered DC supply or RF-induced hum. Filtering is built into the MPX2000, so a pretty poor DC supply will be tolerated, but this is still not recommended. If improving the power supply filtering does not help, the hum is most likely RF induced. In this case, you may have to experiment with antenna placement, grounding, and RF chokes in

Build Your Own Low-Power Transmitters: Projects for the Electronics Experimenter

the power leads. A metal case is a help in some cases because it provides some shielding and grounding via its self-capacitance.

Antennas

In keeping with Part 15 FCC requirements, the radiated field must be kept below 250 microvolts per meter at 3 meters (about 10 feet) from the transmitter. The use of a 6-inch whip antenna is recommended. If the receiver is close to the MPX2000 and a plastic case is used for packaging, no antenna is needed because sufficient signal will radiate from the PC board itself to be detectable. In practice, this 250 uV/meter at 3-meter limit permits good reception at 50–500 feet from the transmitter, depending on the receiver sensitivity and its antenna system. *Do not* connect any more antenna than you need, or you may receive an FCC citation.

Parts List

Resistors 5% 1/4 W unless noted		QTY
R1, R2, R14, R15, R32, R112, R117, R124, R131	4.7 K	9
R3, R4, R5, R6, R28, R29, R30, R31, R33, R34, R35, R36, R45, R51, R54, R56, R57, R62, R63, R64, R66, R67, R70, R104, R105, R106, R107, R111, R118, R128	10 K	30
R7, R40	pot, PT10, 10 K	2
R8, R9, R18, R19	47 K	4
R10, R11, R58, R65	15 K	4
R12, R13	9.1 K	2
R16, R17, R44, R48, R69, R100, R101, R102, R103, R123, R125, R132, R216	1 K	13
R20, R21, R22, R23, R37, R38, R109, R127	100 K	8
R24, R25	39 K	2
R26, R27, R50, R121	22 K	4
R39, R41	68K	2
R42, R43, R52, R53, R71, R114	2.2 K	6
R46, R47, R133	3.3 K	3
R49, R119, R217	220 K	3
R50, R121	22 K	2
R55	pot, PT10, 25 K	1
R60, R116	6.8K	2
R68	pot, PT10, 100 K	1
R72, R126, R130	220 ohm	3
R73	1.5 K	1
R74, R77	390 ohm	2

Microprocessor-Controlled FM Stereo Transmitter for 88-108 MHz

Resistors 5% 1/4 W unless noted (cont.)		QTY
R75, R76, R108, R136	100 ohm	4
R78	470 K	1
R79, R110, R129	2.2 Meg	3
R113	330 ohm	1
R115, R135, R219	470 ohm	3
R120	330 K	1
R59, R122	33 K	2
R134	33 ohm	1
R61, R138, R218	pot, PT10, 1 K	3
R139, R141	91 ohm	2
R140	75 ohm	1
R201, R202, R203, R204, R205, R206, R207, R208	2.2 K 1/8 W	8
R209, R210, R211, R212, R213, R214, R215	150 ohm	7
R220, R221	56 ohm	2
Capacitors		
C1, C2	4.7 uf elec 35V	2
C3, C4, C45	.01 uf 10% mylar 50V	3
C5, C6, C16, C18, C22, C36, C48, C56, C57, C207	10 uf 16V elec 16V	10
C7, C8, C9, C10	100 pf 5% NPO ceramic	4
C11, C19, C20, C21, C30, C51, C52, C59	1 uf 50V elec	8
C12, C13, C26, C27, C35, C37, C38, C44, C201	.01 uf ceramic 50V GMV	9
C14, C15, C39, C50	22 pf 5% NPO ceramic	4
C17	.0015 uf 10% mylar 50V	1
C23, C29	1000 uf 16V elec	2
C24	2200 uf 25V elec	1
C28	0.1 uf mylar 50V	1
C31	47 pf 5% NPO ceramic	1
C32	120 pf 5% NPO ceramic	1
C33	68 pf 5% NPO ceramic	1
C34, C40, C43, C58	470 pf disc ceramic GMV	4
C41	6.8 pf NPO ceramic	1
C42	0.47 or 1.0 uf 35V tantalum elec	1
C46	10 uf 6V tantalum elec	1
C47, C202, C203, C204, C205	0.1 uf chip, 60 × 120, 50V	5
C49	2-20 pf trimmer, 7.5mm	1

Build Your Own Low-Power Transmitters: Projects for the Electronics Experimenter

Capacitors (cont.)		QTY
C53, C55	47 uf 16V elec	2
C54, C206	470 uf 6.3 V elec	2
Diodes, Transistors, and LEDs		
D1	1N4007	1
D2	Not used	—
D3	MV2103 or equiv.	1
D4	MV209 or equiv.	1
D5 thru D14	1N914B or 1N4148	10
D201	T1 3/4 Red LED	1
D202	T1 3/4 Yellow or Orange LED	1
D203	T1 3/4 Green LED	1
DS201	Seven segment 2 digit LED subassembly	2
DS202	Ten-segment Bar Graph assembly, yellow	1
Q1, Q2, Q3, Q5	2N3904	4
Q4, Q6, Q201, Q202, Q203, Q204	2N3906	6
Q7, Q10	2N3563	2
Q8	MPF102	1
Q9	MPS3866 or 2N3866	1
Integrated Circuits		
IC1	TL084N	1
IC2	MC1496N	1
IC3	MC1458N	1
IC4, IC13	74C00N	2
IC5	CD4040BE	1
IC6, IC7	LM7812	2
IC8	PIC16F84-04	1
IC9	MC145170-2	1
IC10	TLO81N	1
IC11, IC12	LM7805N	2
IC201	74HC573N	1
IC202	74HC138N	1
IC203	7447N	1
IC204	LM3914N	1

Microprocessor-Controlled FM Stereo Transmitter for 88-108 MHz

Miscellaneous		QTY
S201-S212	Touch switches, momentary contact	12
L201, L202	Ferrite toroid 3E27 Matl	12
L1, L2, L3	See Text and Figure 9-9	
X1 Crystal, 4.864 MHz		1
X2 Crystal, 4.000 MHz		1
Header, 0.1", 10 pins		2
Header, 0.1", 8 pins		1
IC socket, 18 pin		1
IC socket, 20 pin		1
Label, Keyboard		1
3 ft #24 enamelled wire		1
2 ft #22 tinned wire		1
1 ft #18 tinned wire		1
Ribbon cable, 8 inches, 24 conductor		1
PC board, main		1
PC board, display		1
Ferrite beads, 43 Material		2
4-40 × 1/2" BHMS		2
4-40 Hex Nut		2
4-40 Lockwasher		2

A kit of parts, consisting of complete documentation, drilled and etched printed circuit boards, and all parts that mount on them, as well as keyboard, hardware, and a case are available from:

North Country Radio
P.O. Box 53, Wykagyl Station
New Rochelle, NY 10804-0053
E-mail: support@northcountryradio.com
Website: www.northcountryradio.com

Check their website for current price and an order form.

This Page Intentionally Left Blank

10. 20 mW Low-Power TV Transmitter

For short-range transmission of TV signals (50–200 feet), a power level of around 1–10 milliwatts (mW) RF output is adequate. This chapter describes a low-power transmitter suitable for this purpose. This unit operates at the lower VHF frequencies and can be used as an educational project for experimenting with TV transmitters in general; however, note that currently, the act of broadcasting any signals on VHF TV channels in Part 15 fashion is not legal in the United States under current FCC rules. You may cause interference with licensed commercial TV stations and/or interfere with TV reception in your neighborhood if you do not or cannot confine the signal to your own property. Therefore, an antenna should not be used if you cannot guarantee this provision. The circuit will radiate enough RF by itself to be detectable on a closeby TV receiver. This circuit can also be used as a cable driver, where the cable run is long. The relatively high output (+7 to +10 dBm) will allow cable losses of almost 60 dB, while still delivering an adequate TV signal level into a receiver (–50 dBm). This amount of loss is huge, allowing cable lengths of 1000 feet or more plus a few splitters. This system may drive hundreds of TV receivers or more. Another application of a transmitter such as this one is driving several monitors in a security system. The cable just has to handle RF, and other signals can use the cable as long as they occupy a different frequency range. A simple example of this application is shown in Figure 10-1, where two cameras feed two monitors over a single cable.

Baseband video is sent from camera 1 to the monitor, while the RF channel is used for the second channel. Note that a demodulator is needed at the input of monitor 2, unless this monitor contains its own tuner and IF system, as does an ordinary TV receiver. In addition, the cable could be used to carry DC power to cameras 1 and 2 and the transmitter, therefore serving another function. This can be achieved using an active regulator network as shown in Figure 10-2. Basically, a transistor

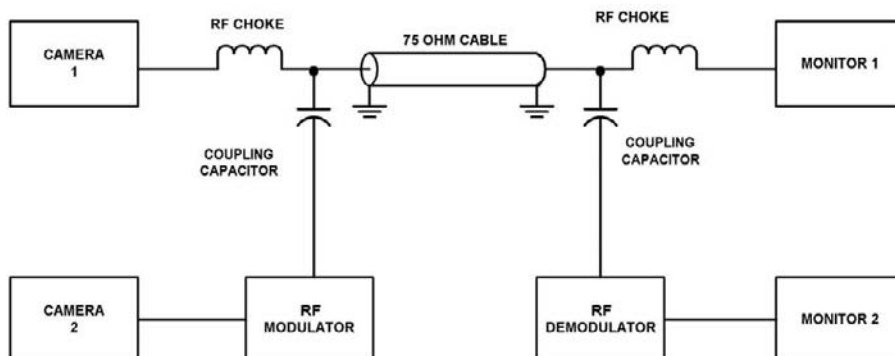
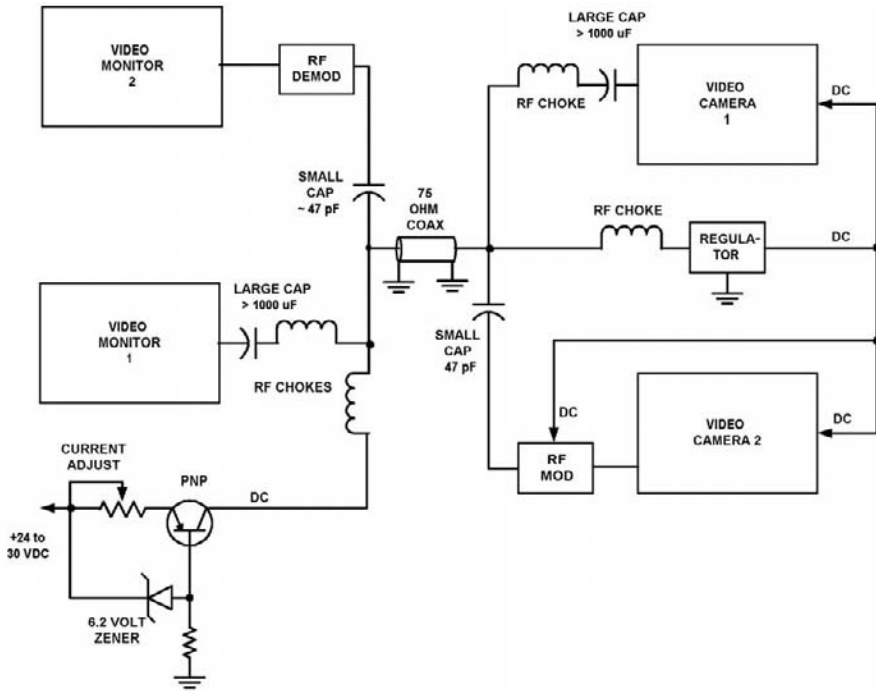

Figure 10-1
How to Send Video Signals from Two Cameras Over One Cable

Figure 10-2
Feeding DC and Video Over One Cable Using Two Cameras and Two Monitors



acting as a current source, with a high impedance to video signals, feeds DC to the cable center conductor. This DC level may be 15–30 volts or more. At the receiving end, another regulator removes the video and RF components from the DC. The video components are coupled through a capacitor and RF choke system onto the cable. A similar arrangement at the monitor end passes these signals to the monitors. Exact component values in any given system may differ from those shown because of individual equipment interface requirements, but these values would be typical.

A very simple approach is used here. Rather than “reinvent the wheel,” a prepackaged video modulator is used to generate the RF signal. These devices typically produce 1 mV output into 75 ohms, and will output on VHF channel 3 and 4. This approach is more cost effective than building up an RF oscillator and video modulator and the necessary sound subcarrier oscillator system. This also makes the project easier to build. Those wanting a higher-power unit will find several of them in later chapters. Inputs will handle standard video and audio line levels directly, so interfacing with existing equipment should not present any problems. The transmitter is made up of one of these modules, a bandpass filter, and a linear amplifier with enough gain and good linearity to produce the final output.

Referring to the schematic (Figure 10-3), modulator M1 generates a composite video signal on VHF channel 3 or 4, as selected by a switch S1. In some modulators, S1 is incorporated as an integral part, whereas in others an external lead must be grounded to change the channel. Audio and video are inputted to jacks J1 and J2, respectively. RF composite output consisting of the sound and picture signal appears on the center pin of the modulator output. This is usually an F connector. This signal is coupled to a bandpass filter consisting of capacitors C1 through C6 and inductors L1 and L2. This filter removes out-of-band components and bandlimits the signal fed to the amplifier stages. It also reduces unwanted lower sideband (vestigial)

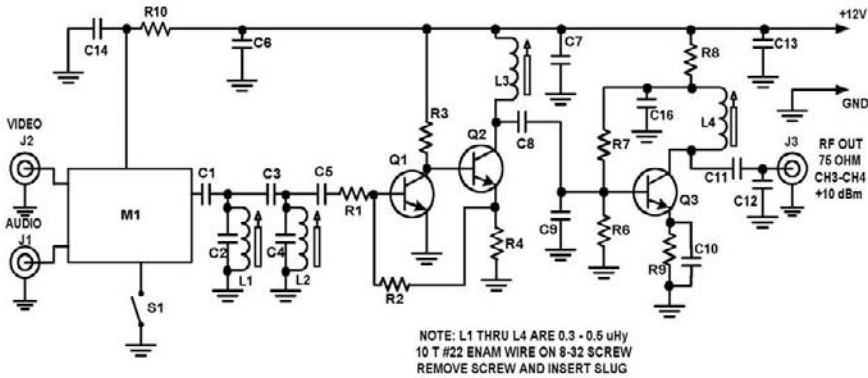

Figure 10-3
Schematic of a
Simple Video
Transmitter/Cable
Driver

components to some degree. Following the filter is an amplifier stage Q1-Q2, R1 through R5, and L3, C8, and C9. This stage is a shunt feedback pair with approximately 35 dB gain. R2, R3, and R4 are biasing resistors, and R1 and R2 determine stage gain. Tuned circuit L3, C8, and C9 couple the signal to output amplifier Q3. Q3 is set up as a linear amplifier class A stage for low distortion. R6, R7, R8, and R9 are biasing resistors, and C10 and C13 are bypass capacitors. Output signal at the collector of Q3 is coupled to output jack J3 by tuned circuit L4, C11, and C12. The entire circuit is powered from 12 volts DC, with R10 and C14 serving as dropping resistors to provide the 9 volts needed by the modulator assembly.

Construction can be any suitable method that provides good shielding between the input of the amplifier and the output because this amplifier has 50–60 dB of gain. The use of “ugly bug” construction using double-sided G-10 material, or alternately sheet brass or copper, is recommended. In this way, shield partitions can be placed between stages, with suitable holes for signal feedthroughs provided. Physical layout should flow like the schematic, with signals progressing in a straight line, so inputs are well separated from outputs (see Figure 10-3). G-10 can be worked with simple hand tools and can be cut with metal snips or a paper trimmer. G10 is cheaper, stronger, lighter, and easier to work with than thin sheet brass or copper and takes less heat to solder. It may be somewhat homely in appearance, but it works very well. Observe carefully the transistor orientations and proper lead identification of the modulator. Start by building the modulator support circuitry first (J1, J2, R10, C14) and mounting the modulator to the circuit assembly so it can be powered up. It would be wise to test the modulator by connecting the RF output of the modulator to a TV set tuned to channel 3 or 4 and observing that input video at J1 and J2 produce a good-quality picture and sound in the TV receiver. This test should be performed before building the rest of the circuit. Then the amplifier can be built up one stage at a time and checked out, if desired, to see if any problems are present.

Tuneup consists of adjusting the slugs in L3 and L4 for maximum output. This can be observed on a receiver with a signal level meter or by adjusting for best picture. In this case, a suitable attenuator pad of 60 dB or so should be connected between the transmitter and antenna input of the TV set to simulate path (transmission) loss. L1 and L2 are adjusted so that the filter has a flat bandpass over the 60–66 or 66–72 MHz range for either channel 3 or 4 as desired. This can be done either with a sweep generator or by simultaneously adjusting for maximum RF output at J3, consistent with good video response, which is indicated by freedom from smear or ringing, correct color, and good sound and picture being received simultaneously.

Build Your Own Low-Power Transmitters: Projects for the Electronics Experimenter

The adjustments are relatively broad and should pose no problems. Make sure to use an insulated, nonmetallic tool to adjust the slugs because a metallic tool causes detuning and false results. The RF output can be coupled to a cable of 75 ohms to interface with a distribution system or antenna. Make sure your power supply is free from 60- and/or 120-Hz ripple because this could show up as hum bars or a slowly moving upward “bend” in the received picture.

11. 0.5-Watt TV Transmitter for R/C Vehicles

This chapter describes a small transmitter that interfaces directly with a small PC board camera. The transmitter can be placed in an R/C vehicle, with the camera used to give a pilot's or driver's-eye view from the model. This allows direct control by eye because the operator's "eye" (video camera) is (or can be) located in the pilot's seat. The picture is viewed on a color or black-and-white monitor and can even be videotaped. This transmitter board accepts an NTSC or PAL video signal and generates a corresponding RF signal modulated with this information, in the 420–440 MHz band. This signal can be received on any standard TV receiver fitted with a suitable RF downconverter capable of tuning the 420–450 MHz amateur band. If the TV receiver is capable of tuning these frequencies directly, no converter is needed. Channel 60 on some cable-ready sets is 439.25 MHz, and it is possible to modify certain sets to do this, but for best results a dedicated downconverter outputting on an unused VHF channel (channel 3 or 4) is the preferred method. This allows an optimized RF front end and best reception range.

The small size (1.75 inches by 2.75 inches) is compatible with many small color and black-and-white PC board cameras. Operation is possible from nominal 9- to 14-volt power supplies, with minor adjustments in video drive. Lead acid, nicad, or alkaline power packs may be used. Less than 8 or more than 15 volts is not recommended. Power output is typically from 0.3–1.0 watt over this range. A crystal is specified for operation at 439.25 MHz, but operation over 400–520 MHz is possible. Power output is generally slightly less at the higher frequencies.

The transmitter requires standard NTSC or PAL video. The video input requirement is standard 1-volt point-to-point 75 ohms, negative sync. The video amplifier and modulator is AC coupled, with adjustable clamp (black) level.

Note that a valid amateur license permitting operation in this band is a requirement for operating this device. In the United States, this means owning a code-free license, so if you can build this transmitter, you should easily be able to pass the required examination. Operation of this device on commercial TV frequencies is illegal in the United States. For use in other nations, check local laws. It is intended for operation by legally licensed amateurs and for no other purpose.

The transmitter can be easily assembled in two to four evenings, depending on experience. There is some small work, so suitable fine tools should be available. Some experience and familiarity with RF circuitry is assumed, but the average electronic hobbyist will have few if any problems.

The following test equipment should be available:

- VOM or DVM
- Power supply 0–15 volts DC at more than 400 mA well regulated
- A 50-ohm load good at 500 MHz, preferably with an RF indicator

Build Your Own Low-Power Transmitters: Projects for the Electronics Experimenter

- Frequency counter (optional but useful)
- TV receiver capable of tuning to transmitter frequency
- Cables and test leads as needed
- Source of video and audio (VCR is usable, or a camera)

If no test equipment is available, try to borrow some or ask for help from another amateur or hobbyist. The best results require at least the listed equipment to verify correct operation.

A brief circuit description is now given. The transmitter schematic is referred to. It is not possible to later add a sound section to the PC board; however, an outboard section can be built later and connected in. This choice is left to the experimenter. A small audio narrowband FM transmitter is described in another chapter in this book.

Referring to the schematic in Figure 11-1, Q1 is a crystal-controlled oscillator using a 54.90625-MHz crystal in a common base circuit. At the series-resonant frequency of the crystal, the base of Q1 is nearly grounded. L1 and C2 are tuned slightly above resonance, causing oscillation at the crystal frequency. The signal generated contains harmonics. Filter L2, C3, C4, L3, C6, and C7 couple the second harmonic 109.8125 MHz to doubler stage Q2. This stage further doubles the signal frequency to 219.625 MHz. Filters C9, L4, C10, L5, C11, and C12 eliminate all other frequencies and match the input of the next stage, Q3, which is another doubler. Q3 doubles this signal to the final output frequency—439.25 MHz. At this point, about 30–50 mW of RF energy is present. C13, L6, C14, L7, C15, L8, C16, C17, C18, L9, C19, L10, and C20

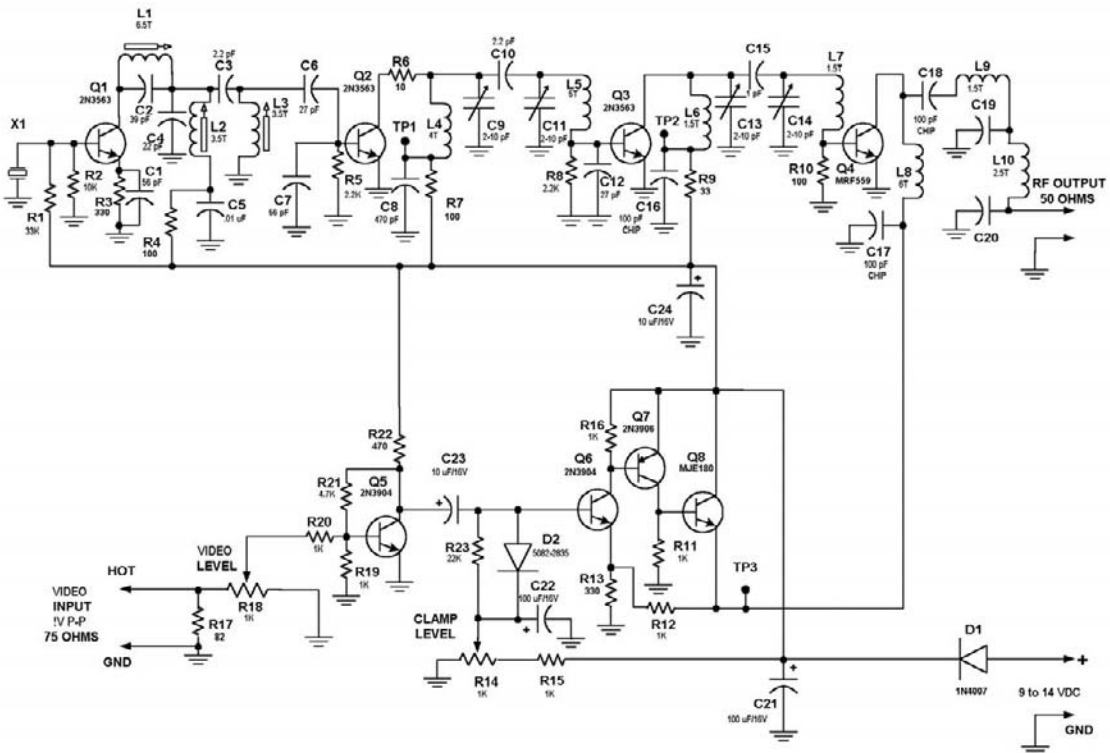

Figure 11-1
Schematic of the 0.5W Video Transmitter ATV Jr MKII

constitute a matching network to couple this energy to Q4 and filter out spurious unwanted signals. Q4 amplifies this signal to between 0.5–1.0 watt, depending on supply voltage. L8, L9, C18, C19, L10, and C31 match the collector impedance of Q4 to a 50-ohm load and help suppress higher harmonics. The output is therefore a relatively pure signal at 439.25 MHz.

In order to apply video modulation to this RF carrier, the supply voltage for Q4 is taken from the emitter of modulator Q8. Q6, Q7, and Q8 are connected as a feedback amplifier with a gain of about 4. Video input to the transmitter is amplified in Q5, which has a nominal gain of approximately 5. A total voltage swing of up to 12 volts, peak-to-peak is needed from the modulator. Therefore video inputs as low as 0.6 volts peak-to-peak can be used. R17 is a termination resistor, and R18 is the video gain control. R19, R21, and R22 bias Q5, and R20 sets the stage gain. Q5 circuit produces an output inverted in polarity so that sync and black levels are positive going. C23 couples video to clamp circuit D2, R23, C22, and R14. The signal is clamped on positive peaks to a reference level set by R14. An ideal clamp has a low-source impedance and high-load impedance, which this circuitry provides. The video signal at the base of amplifier Q6 is amplified by a factor of four and is superimposed on the DC supply by Q7, which amplitude modulates the RF output from Q4. R14 sets the carrier level of the RF output for symmetrical modulation, and R18 sets the modulation level for maximum without distortion or clipping. D1 protects the circuitry against accidental reverse polarity, and C24 provides supply line bypassing. The DC supply to the transmitter should be clean and stable because any noise or ripple in the supply voltage can modulate the RF carrier and could cause severe distortion in the received video. Less than 50 mV of ripple and noise is necessary, less being desirable.

Construction is not difficult, assuming you have the proper tools and use good PC board assembly techniques. A magnifier is necessary to see color codes of small parts with any certainty. Check any dubious items with a VOM to be sure. If you are not sure about a part, use the process of elimination to help narrow it down. It is helpful to first insert larger parts, such as trimmer caps and potentiometers, to serve as landmarks. Because of the small size and tight layout of this transmitter, screening was not used. The larger holes on the board are for the trimmers and pots. Note that all trimmer capacitors and grounded leads of resistors must be soldered on both sides of the board. This step is essential for good RF grounding. Except where access may be difficult later, *do not* solder any connections until as many components as possible are inserted. All coils are installed after components are inserted, and this is the only exception. *All* parts are mounted tight and close to the board, with no exceptions. *Zero* lead length is a must in RF circuits. You should use only rosin core solder, with low residue preferred. *Do not* use acid core or any paste fluxes. A hot, small pencil iron is best. Remember that you are working at UHF frequencies and lead lengths are critical. They should ideally be *zero*.

Begin construction by inserting all trimmer capacitors in the PC board (see Figures 11-2 and 11-3). Make sure that the correct values are inserted. Note the large hole for Q4. Orient the board so that this hole is near the top right. After making sure that the correct parts are installed, solder the side terminals to the top side of the PC board. Be careful not to melt the plastic. Do not solder the bottom at this time.

After carefully identifying them, mount all resistors. Only solder the top of the board, where the resistor lead passes through the ground foil. Solder as many as you can. Do not solder the bottom yet. Next, install capacitors. Any that come with preformed leads should have these leads straightened with pliers to fit close to the board.

Figure 11-2
Parts Layout of the
Component Side
of the ATVJr MKII

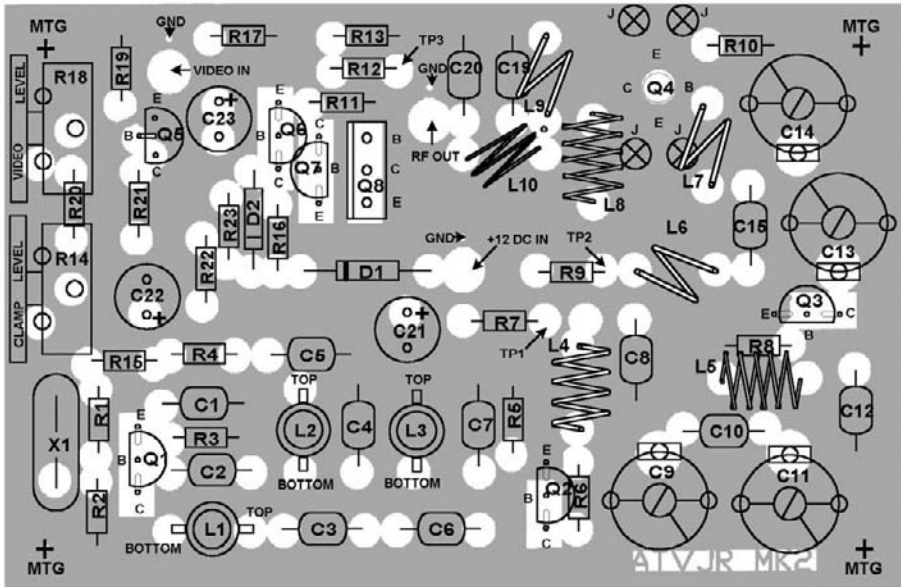
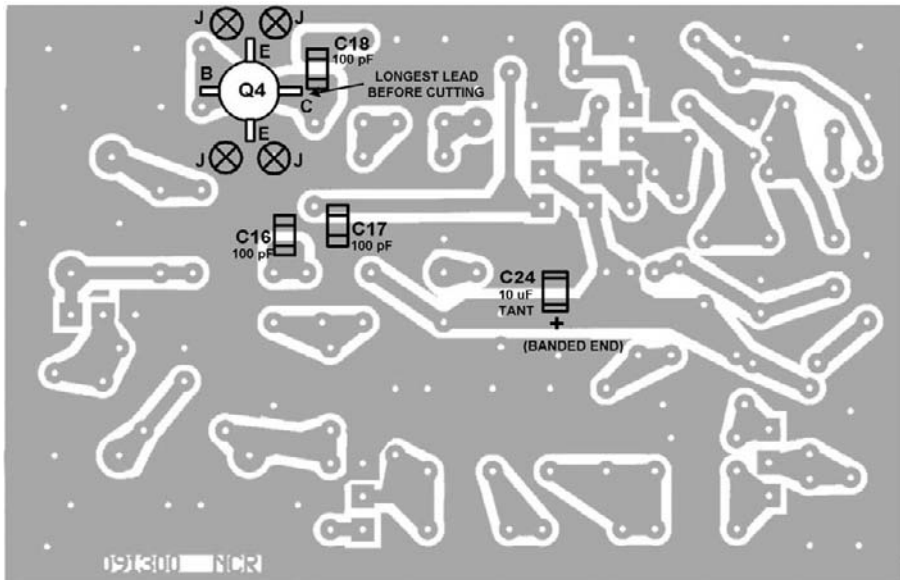

Figure 11-3
Parts Layout of the
Solder Side of the
ATVJr MKII



Watch the polarity of all electrolytic capacitors. Do not install chip capacitors yet because they will be installed later. Identify and install all transistors, except the MRF559 (Q4), which will be installed later. *Watch for correct orientation.* All transistors should be 1/8 inch from the surface of the board. Solder the emitter leads of Q2 and Q3 to the top of the PC board, where they pass through the ground foil. Install D2. *Watch the polarity.* Using scissors, trim crystal leads to 3/16ths inch and install. *Do not* use diagonal cutters because the shockwave can damage the crystal. Solder a short wire to the top of the crystal, and run this to ground. Use resistor lead

clipping or another scrap of wire. Carefully check all work completed so far for accuracy and orientation. Now, trim all component leads to length, if not done yet, and solder all bottom connections made so far. Do not plug up any unused holes yet.

Carefully fabricate all coils as shown in Figure 11-4, and install them in the PC board. Be sure that no turns short together on L4, L5, L7, L8, L9 and L10, and that L1 has a bottom turn connected to C2 and Q1, L2 has a bottom turn connected to the junction of C3/C4, and L3 has a bottom turn connected to the junction of C3/C6. Use an 8-32 screw to hold L1, L2, and L3 during installation. After installing, remove the screw and fully insert the ferrite slugs. Using leftover lead clippings, fabricate TP1 and TP2. Install them so that about 3/8ths inch projects above the top of the board. Install a 1-inch piece of bare tinned wire in +12-volt connecting hole to serve as a terminal. Place a piece of sleeving over these points if desired, to avoid shorts. Install C16, C17, C18 (100 pf chips), C19, C20 (10 pf chips), C22, and D1 under the PC board. Watch the polarity of C21 and D1. Band is the positive side.

L1, L2, & L3

Wind coils using #22 enamelled wire. Use 8-32 machine screw as a mandrel, winding wire in screw threads to form coil. Form leads, as shown, remove enamel and tin before installation. Install in PC board using screw as holding tool. Remove screw and insert slugs.

L1 = 6.5 Turns

L2, L3 = 3.5 Turns

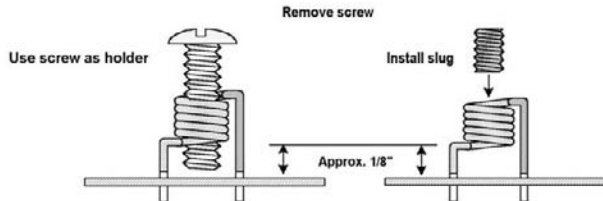
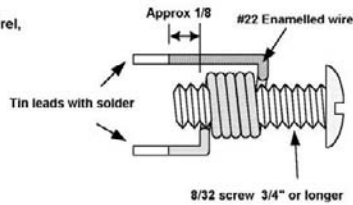
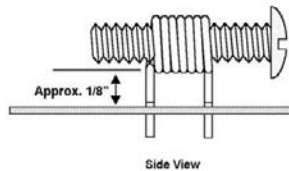
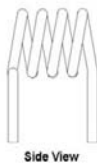

Figure 11-4
Coil Winding
Information for the
ATVJr MKII

L4, L5, & L8

Wind coils using #22 bare. Use 8-32 machine screw as a mandrel, winding wire in screw threads. Form leads, as shown. Install in PC board using screw as holding tool. Remove screw. No slugs are used. Install in PC board as shown.

L4 = 4 Turns
L5 = 5 Turns
L8 = 6 Turns



L6, L7, L9 & L10

Wind coils using #22 bare. Use 8-32 machine screw as a mandrel, winding wire in screw threads. Form leads, as shown. Install in PC board using screw as holding tool. Remove screw. No slugs are used. Install in PC board as shown.

L6, L7, L9 = 1.5 Turns

L10 = 2.5 Turns

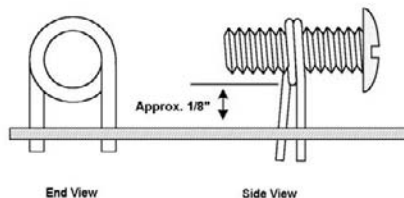

Refer to the detailed chip installation instructions in the Appendix. Install four grounding jumpers in four holes that you see placed around the Q4 hole. These jumpers are very important. Now install Q4. The long lead is the collector. Trim the leads to length and install them such that Q4 has the thicker side in the hole. The plane of leads should be flush with the bottom of the PC board. Carefully inspect all work so far. Look for solder shorts, poor joints, missing parts, incorrect parts placement, and so forth. You are ready to check out the board once everything is satisfactory.

Do not proceed with this section until you have thoroughly checked out the construction as described in the last step of the instructions. You should have access to the suggested test equipment if you want to obtain good performance. It is futile to try to tune for best picture. For example, it is possible to get a good picture and have only a 10-foot range of transmission. It is also possible to inadvertently overload your monitor and get a lousy picture on it from a perfectly working board and spend hours tracing nonexistent problems. Therefore, use our procedure and experiment later when you are sure that everything works properly.

Your first step is to verify that the DC voltages are correct and that the modulator is working. Set your power supply to 0 volts. Connect the negative lead of your power supply to the ground foil on the board. Next, connect a lead from the positive terminal of the supply through an ammeter (0–1 A range) to the power input (see layout drawing). If your power supply has an ammeter, you can use it instead. Now slowly raise the voltage to 10 volts. If more than about 100 mA (0.1 A) is drawn, this is suspicious: check your board for errors and/or shorts. Now check to see if anything gets hot or smokes. If so, find the cause before going further. If everything is correct so far, set the supply voltage to 13.2 volts and check for the following voltages. (All voltages are read with the negative meter lead to the negative lead of supply.)

Collector Q8: +13.2 VDC

Collector Q1: +12.6 VDC

Collector Q2: +13.2 VDC

Collector Q4: Varies from less than +3 to more than +11 VDC

Emitter Q7: Varies with setting of R18

Verify these settings before proceeding further. If all voltages are correct, leave R18 set for full voltage on the emitter of Q8. This should be at least 11 volts. If necessary, reset R18 so you get the 11 volts or more. Next, the RF circuits will be tuned up and checked out. The RF stages Q2, Q3, and Q4 are all operated in class C mode. This means that, in the absence of a drive signal, they are “off” and draw no current. The application of drive causes the stage to turn “on” and draw a current that is somewhat proportional to the drive signal, up to a point. Therefore, by monitoring the collector current of a stage, we can monitor the drive signal a stage is getting at its input. This fact is used to tune the interstage RF coupling networks. TP1 and TP2 are used to monitor stage currents by reading the DC voltage drop across resistors in the collector circuits. Typical collector current of stage Q2 is 10–15 mA, and Q3 is 20–30 mA.

Connect the positive lead of your VOM or DVM to the power input lead. Set the supply voltage to 13.2 volts. Connect the negative lead to TP1. Set the slug in oscillator coil L1 all the way inside. Now back out the slug with a *plastic* alignment tool, while watching the meter. At some point, the voltage reading on the meter should sharply jump up to a reading. Now back the slug of L1 out a little more so the reading decreases about 5–10 percent. Next, adjust the slugs of L2 and L3 for maximum

reading. Repeat until no further increase is obtained. *Do not* use a DVM for this step. The sampling intervals can be spaced too long in time, and the first quick “blips” in current may be missed. Next, remove power and set trimmer capacitors as follows (assuming specified trimmers are used):

- C9: 1/3 mesh
- C11: 2/3 mesh
- C13: 1/2 mesh
- C14: 1/4 mesh

See Figure 11-2 for locations of these parts. Now connect a *good* 50-ohm dummy load suitable for 500 MHz to the output of the RF power amplifier (C20 and ground). Use a 50-ohm coaxial cable and make connections *short* at C20 and ground. Connect the cable to the load using a suitable connector to match your load (BNC or N usually). RG188 or RG316 Teflon coax is preferred, but RG174 PVC type is perfectly usable if you are careful not to use too much heat in soldering it. Some sort of indicator on the RF load is highly desirable.

Restore power to the board. Readjust L2 and L3 as before. Now remove the meter lead from TP1 and connect it to TP2. Adjust C9, C11, and C12 for maximum reading. Readjust L2 and L3 to further maximize this reading. Now repeak C9, C11, and C12. Continue this process until no further increase can be obtained. The settings for the trimmers should not be too far from the preset positions. If they are radically different, check to see if L4 and L5 are properly wound and that the correct parts are installed in the circuit board positions. About 1.4 volts would be typical at TP2 and 2 volts at TP1 in a correctly operating circuit.

Next, adjust C13 and C14 for maximum RF power output as seen at the indicator on the dummy load. If the indicator is calibrated in power levels, about 0.5 watt or more should be obtained. If no indicator is available, a 0–500 mA meter connected in series with the supply positive lead can be used as a *rough* indicator. In this case, adjust C13 and C14 for maximum DC current draw, which should be 250–300 mA. The transmitter should be checked at some time when you can gain access to a suitable power meter to verify correct operation. If no indicator is available, you can adjust the turn spacing of L9 and L10 to optimize output if less than 0.5 watt is obtained. Do not space turns more than twice the wire diameter. Q4 will get fairly warm but not burning hot, as will Q8 during operation. This response is normal. *Do not operate without a load on the RF output* or you may destroy Q4 and possibly Q6, Q7, and Q8. If desired, you can now go over the previous steps to further optimize output. If you plan to operate from a 9- to 11-volt supply, it would be best to set the supply to the intended voltage and repeak all adjustments so far. Leave the supply at this voltage for the rest of the tuneup procedure at lower supply voltages, maximum RF output will be less (0.25 watt at 9 volts, typically).

The last step is the checkout of the video modulator. You will need a suitable receiver or monitor capable of tuning to 439.25 MHz or to the frequency of whatever crystal you have installed. Connect the transmitter to an antenna located such that its radiating element is at least 5 feet from the board and at least 10 feet from the receiver. No antenna should be needed on the receiver. Connect a source of video (1-volt peak-to-peak 75-ohm negative sync) to the video input of the transmitter (junction of R17 and R18 and ground). A VCR with a tape is an excellent source. Set R18 halfway. Power up the transmitter and adjust R14 so the RF output drops to about 70 percent its original level. Turn on the receiver and activate the VCR or other

Figure 11-5
Solder and Component Side of the
PC Board for the
ATVJr MKII

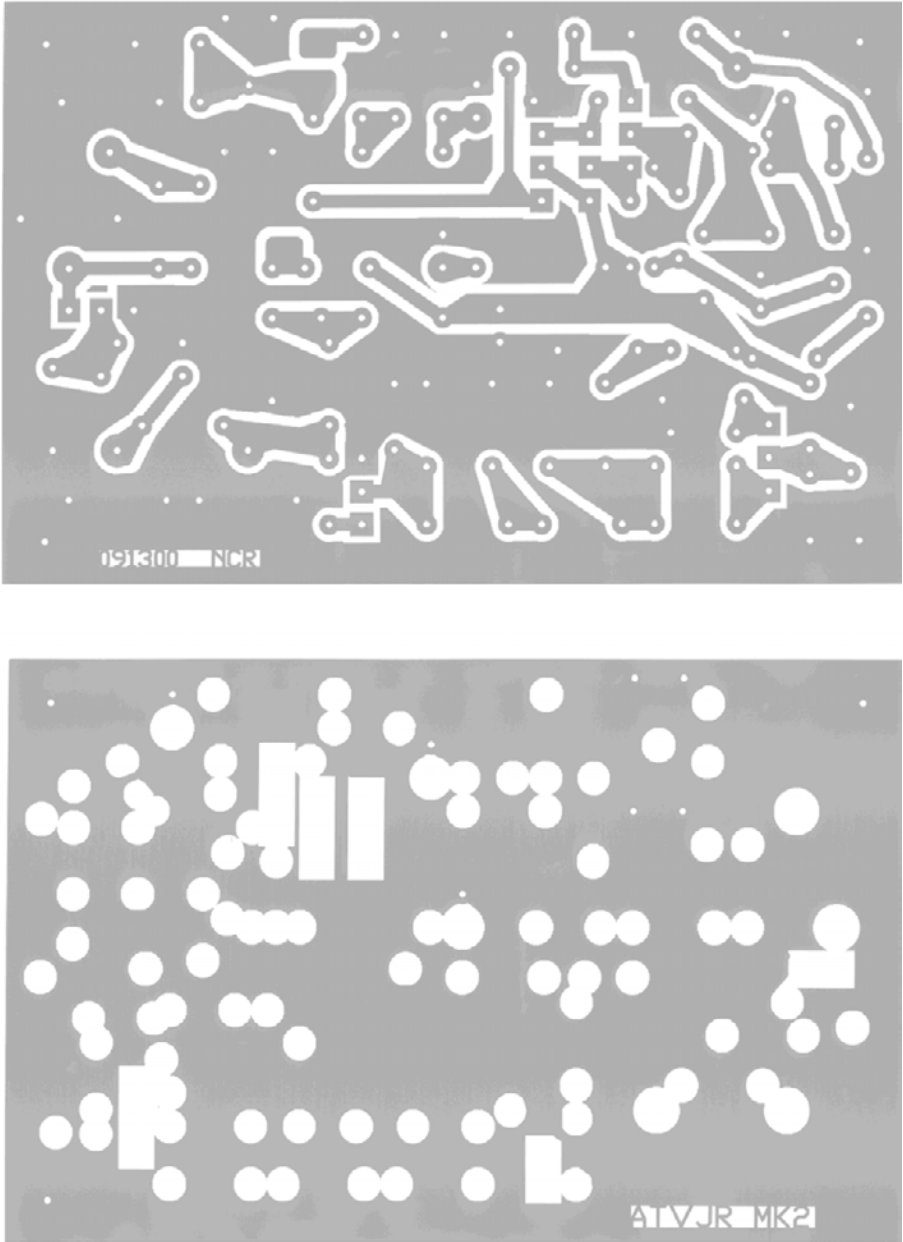

source of video. Watching the picture, adjust both pots R14 and R18 for a good, stable picture, without rolling or white or black level clipping. Readjust R14 and R18 as needed. *Do not* adjust any RF circuit adjustments using the received picture. If a satisfactory picture cannot be obtained, make sure you are not overloading your receiver with excess RF signal and that the transmitter RF signal is not causing interference with your source of video. Some video equipment may not work properly in strong RF fields, so do not immediately assume that the transmitter is at fault.

Remember that the video modulator of the transmitter depends on the DC supply voltage for the clamp reference level and maintenance of certain waveform-level relationships. A drop in supply voltage may cause sync clipping to occur. If this operating condition is expected, it is best to set up adjustments at the lowest expected supply voltage. An increase in supply voltage is much less serious in this regard. The circuit design assumes a reasonably constant supply voltage, -1 to +2.5 volt variation at 12–14 volt levels. At 9 volts, no more than a 0.75-volt drop would be advisable without readjustment of R14 and R18.

After alignment, it is a good idea to glue the slugs in L1, L2, and L3 in place. Use Duco cement or any clear lacquer for this purpose. Do not use pigmented paints because some pigments are conductive and can severely lower the Q of the coils resulting in RF loss. Figure 11-5 shows the PC artwork for the circuit board.

Parts List

Resistors 1/8 watt unless specified		Inductors	
R1	33k	L1, L2, L3	#22 enamelled wire
R2	10k	L4, L5, L6	#22 bare tinned
R3, R12, R13	330	L7, L8, L9	Wire
R4, R7, R10	100	L10	See coil chart for coil-winding details
R5, R8	2.2k		
R6	10		
R9	33		
R11, R12, R15, R16, R19, R20	1K	3 ea.	8-32 ferrite slugs
R17	82		
R21	4.7k		
R22	470		
R23	22k		

Build Your Own Low-Power Transmitters: Projects for the Electronics Experimenter

Potentiometers		Capacitors	
R14, R18	1k Vert. Mount	C1, C7	56 pf NPO
		C2	39 pf NPO
Diodes		C3	2.2 pf NPO
D1	1N4007	C4	22 pf NPO
Transistors		C5	.01 mfd Disc GMV
Q1, Q2, Q3	2N3563	C9, C11,	2-10 pf Trimmer
Q4	MRF559	C13, C14	
Q5, Q6	2N3904	C12	27 pf NPO
Q7	2N3906	C10, C15	1 pf NPO
Q8	MJE180	C16, C17, C18	100 pf chip cap
Crystal		C19, C20	10 pf chip cap
X1	54.90625 MHz Series resonant	C21, C22	100 mfd/16volt
		C23, C24	10 mfd/16 volt
Miscellaneous			
PC board			
8-32 screw for coil winding form			

A kit of parts for this transmitter, consisting of complete documentation, a drilled and etched PC board, and all the parts that mount on the board, is available from the following source:

North Country Radio
P.O. Box 53, Wykagyl Station
New Rochelle, NY 10804-0053
E-mail: support@northcountryradio.com
Website: www.northcountryradio.com

A hardware kit, a two-tone painted aluminum case, and a tuned-to-frequency antenna, are also available from North Country Radio. Check their website for current prices and an order form.

12. 2-Watt TV Transmitter for R/C and Amateur TV for 440 MHz

This 2-Watt ATV transmitter is descended from one originally described in an article in the June/July 1989 issues of *Radio Electronics* magazine. Since that time, many of these transmitters have been successfully used in numerous applications. The circuit has been refined and improved and has proved to be reliable and relatively free of glitches. This latest version is the result of many refinements; therefore, it has become somewhat different in circuitry from the original, although it uses a similar mechanical layout. If you have read about this transmitter in books or previously published articles, or have previously constructed one, you will note these changes and differences from the original unit. This transmitter has been greatly improved and is much better in many aspects than the original design. It has an improved video modulator, remote keying, a better camera interface, improved audio, and a better video clamping circuit. The RF section has been redesigned for easier tuneup and better low-voltage performance. The transmitter will operate better with supply voltage falloff when batteries are used, and three LED indicators are used to facilitate setup and provide a visual indication of circuit operation. Tuneup is also easier and requires fewer adjustments.

General Description

This transmitter board generates a complete NTSC video signal and a 4.5-MHz FM sound subcarrier, modulated on a UHF carrier. This UHF signal can be received on any standard TV receiver fitted with a suitable RF downconverter capable of tuning the 420–450 MHz amateur band. If the TV receiver is capable of tuning these frequencies directly, no converter is needed. Channel 60 on some cable-ready sets is 439.25 MHz, and it is possible to modify certain sets to do this, but for best results a dedicated downconverter outputting on an unused VHF channel (Channel 3 or 4) is the best method. This allows an optimized RF front end and best reception range. The small size (2.5 by 4 inches) is comparable to many small PC board cameras and is small enough for R/C applications in which a video link is needed, surveillance, amateur TV, and for use in a video HT, using one of the pocket TV receivers. Operation is possible from nominal 9- to 14.4-volt power supplies, with minor adjustments in video drive. Lead acid, nicad, or alkaline power packs may be used. Less than 8 or more than 15 volts is not recommended. Power output is typically from 0.5–3 watts PEP over this range. A crystal is supplied for 439.25 MHz. The transmitter requires standard NTSC or PAL video. The transmitter audio can also be retuned for a 5.5-MHz sound subcarrier used by the PAL system. The video input requirement is standard 1-volt point-to-point 75 ohms, negative sync. Audio inputs from 100 mV to 1 volt can be accommodated.

Note that a valid amateur's license permitting operation at 440 MHz is a requirement for operation of this device. In the United States, this is a Technician Class (code-free) license, so if you can build this transmitter, you should easily be able to pass the required examination. *Operation of this device on commercial TV frequencies is illegal in the United States.* Although it may be used for such applications in export situations, in the United States this transmitter is intended for amateur use by legally licensed amateurs and for no other purpose.

The following test equipment should be available:

- VOM or DVM (VOM is preferable)
- Power supply 0–15 volts at more than 1 ampere, well regulated
- 50-ohm load good at 500 MHz, preferably with an RF indicator
- TV receiver capable of tuning to transmitter frequencies
- Cables and test leads as needed
- Source of video and audio (VCR is usable, or a camera)
- Frequency counter (not necessary but useful)

If no test equipment is available, try to borrow some or ask for help from another amateur or electronics hobbyist. The best results require at least the listed equipment to verify correct operation.

Circuit Operation

In this discussion, the transmitter schematic shown in Figure 12-1 is repeatedly referred to. Therefore, it helps if you familiarize yourself with the schematic before reading further. Some ham radio experience and some familiarity with RF circuits and transmitters is assumed. If you are a little unfamiliar with these areas, a little study of the appropriate material in a reference such as the *ARRL Handbook for Radio Amateurs* or *RSGB Handbook* is highly recommended. This background will also help ensure success with this project.

Referring to the schematic, Q1 is a crystal-controlled oscillator using one or two crystals (52–62 MHz) and an onboard jumper to select the desired crystal. This method allows easy frequency change. For single-channel use, only one crystal is needed. If desired, a switch can be wired in place of the jumper to allow switch selection. R1 and R2 feed bias to the base of oscillator stage Q1. The selected crystal effectively appears in series with the base of Q1 and ground. For RF, Q1 is a common base oscillator circuit. At the series-resonant frequency of the crystal, the base of Q1 is nearly grounded. L1 and C2 are tuned somewhat above resonance, causing oscillation at the crystal frequency. The signal generated contains harmonics. Filters L2, C3, C5, L3, C6, and C7 couple the second harmonic 105–125 MHz to doubler stage Q2. This stage further doubles the signal frequency to 210–250 MHz. Filters C9, L4, C10, L5, C11, and C12 eliminate all other frequencies and match the input of the next stage, Q7, which is another doubler. Q7 doubles this signal to the final output frequency in the 420–500 MHz range.

At the output of Q3, about 20 mW of RF energy is present. C14, L6, C15, C16, and L7 constitute a matching network to couple this energy to Q8 in the power amplifier (PA) and to further filter out spurious, unwanted signals. Q8 amplifies this signal to around 0.2–0.4 watts. C19, L9, C20, and C21 form a matching network to match the impedance of the collector of Q8 to the base of final amplifier Q9. L11 is an RF choke, and R12 provides bias for Q9. Q9 can deliver 2 watts or more of RF power to its load via a matching network. L10, C24, C25, C26, L12, and C27 form a

tuning and matching network and a lowpass filter to ensure a spectrally clean RF output to the antenna. C29 and C28 form a capacitive voltage divider that couples a sample of the RF output voltage to a detector diode D4.

The negative voltage is fed through R14 to LED3, a red LED that serves as an RF output indicator. The sensitivity of this indicator may be varied by changing C28. Q9 handles considerable power, and its case is soldered directly to the copper foil ground plane of the PC board to help dissipate heat and to ensure a low-inductance emitter return. Note that the case of Q9 is connected to the emitter, instead of the collector, as is more common practice for TO39 transistors. Therefore, the transistor appears to be pinned in a reverse lead configuration. Video-modulated DC is supplied to Q9 via RF choke L11. R13 and LED2, a yellow LED, serve as a voltage indicator and are used to set up the transmitter and as a modulation indicator. C23 is a bypass capacitor. R11 and C22 are also connected to the same point and serve as bypass and decoupling resistor. In order to apply video modulation to this RF carrier, the supply voltage for Q8 and Q9 is taken from the emitter of modulator Q12. Q10, Q11, and Q12 are connected as a feedback amplifier, with a nominal voltage gain of about 4. Video signal input to the transmitter is fed to video gain control R24 and a termination resistor R28. R26 provides a “stop” for gain control R24 and sets minimum gain. Video is fed from R24 to R25 and the base of video amplifier Q6. This feedback amplifier stage has a gain of around 4.5. The video signal is also inverted in polarity so that sync and black levels are positive going. The video signal from Q6 is coupled to the base of Q10 via C42. D3 and R19 form a clamp circuit, which is biased from a DC voltage of 0–6 volts from the wiper of clamp level control R27.

A large capacitor C43 acts as a bias battery for the clamp circuitry. R27 is adjusted so that the peak sync tips will just about cause the voltage at the emitter of Q12 to saturate (about 1–2 volts less than the supply voltage). This allows a constant sync tip RF level that tends to stay constant with video level and scene changes, maintaining peak power and preserving proper DC levels in the transmitted video signal. The emitter of Q10 is used as an inverting input for feedback divider R15 and R18 and normally sits about 1.5–2 volts above ground. This provides a high-input impedance at the base of Q10 and allows the clamp circuit to function better. R16 biases the collector of Q10, and this point is fed to video amplifier Q11, which drives the modulator transistor Q12. The video present at the emitter of Q12 is superimposed on the supply voltage to Q8 and Q9, causing amplitude modulation of the RF output of Q9. R27 sets the level of the RF output for symmetrical modulation, and R24 is set for maximum modulation level without distortion or clipping.

D1 protects the circuitry against accidental reverse polarity. D1 is usually placed in series with the supply lead, but for low supply voltages, it can be placed across the supply so as not to introduce any voltage drop; however, protection is not as effective in this way as the series connection. C30 provides supply line bypassing. For lowest impedance, C30 is a tantalum chip capacitor. Note that Q12 is effectively in series with the power supply to the RF power amplifier and therefore dissipates considerable power. Therefore, Q12 is heatsinked. Note that the video amplifier is AC coupled. Attention should be paid to video input signal levels and interfacing to ensure proper modulation of the transmitter. Input impedance is 70–75 ohms. Drive is a nominal 1-volt peak-to-peak negative sync, which is fairly standard for most video devices. If a higher-input impedance is desired, R28 can be omitted. Frequency response is about 10 Hz to 4 MHz. The picture quality is excellent if the transmitter is properly set up and video drive levels are correct.

Now a sound subcarrier must be generated to carry audio. Incoming audio is fed to gain control R32. Audio from R32 is then fed through C31 and R33 to Q4. A gain

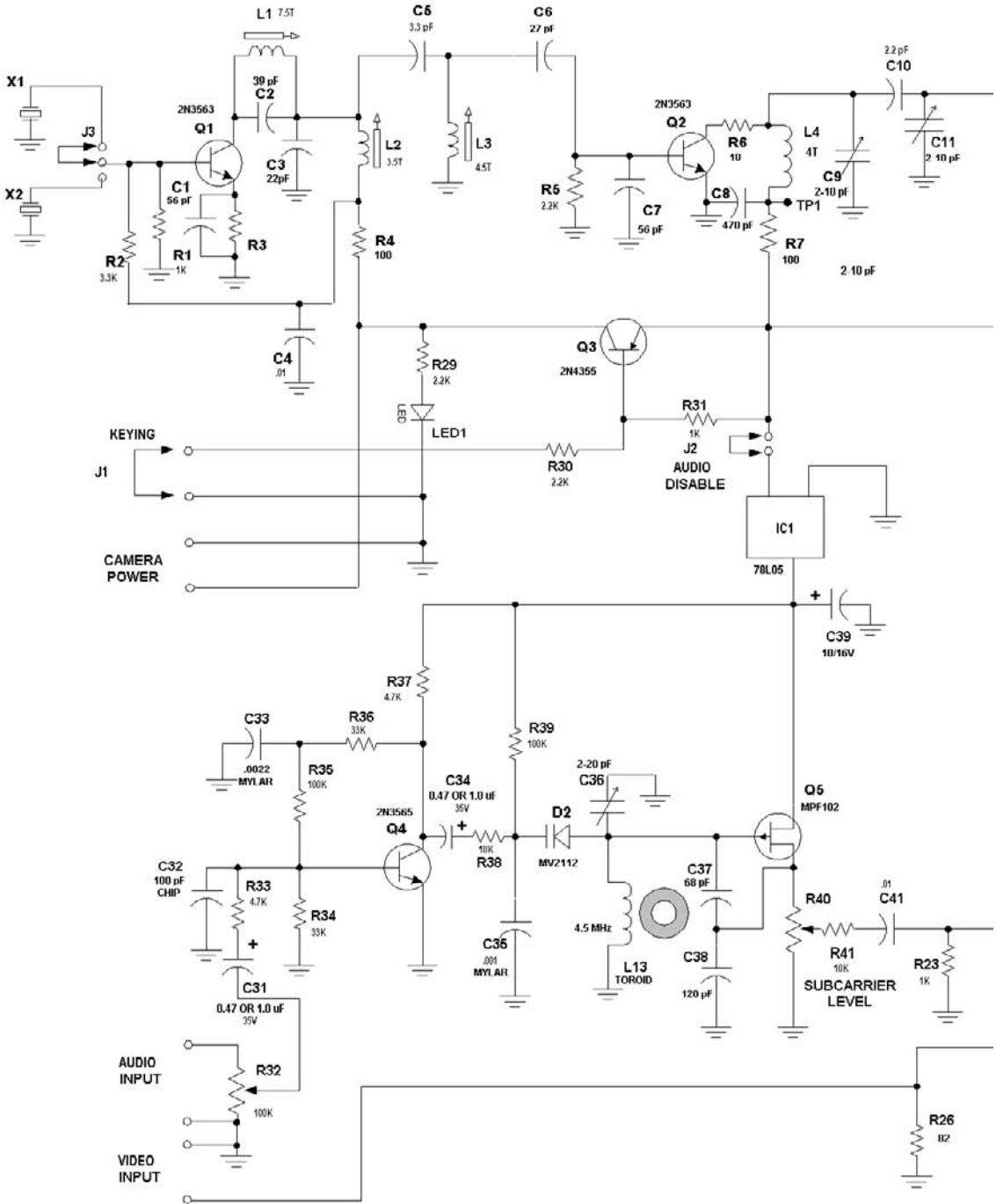
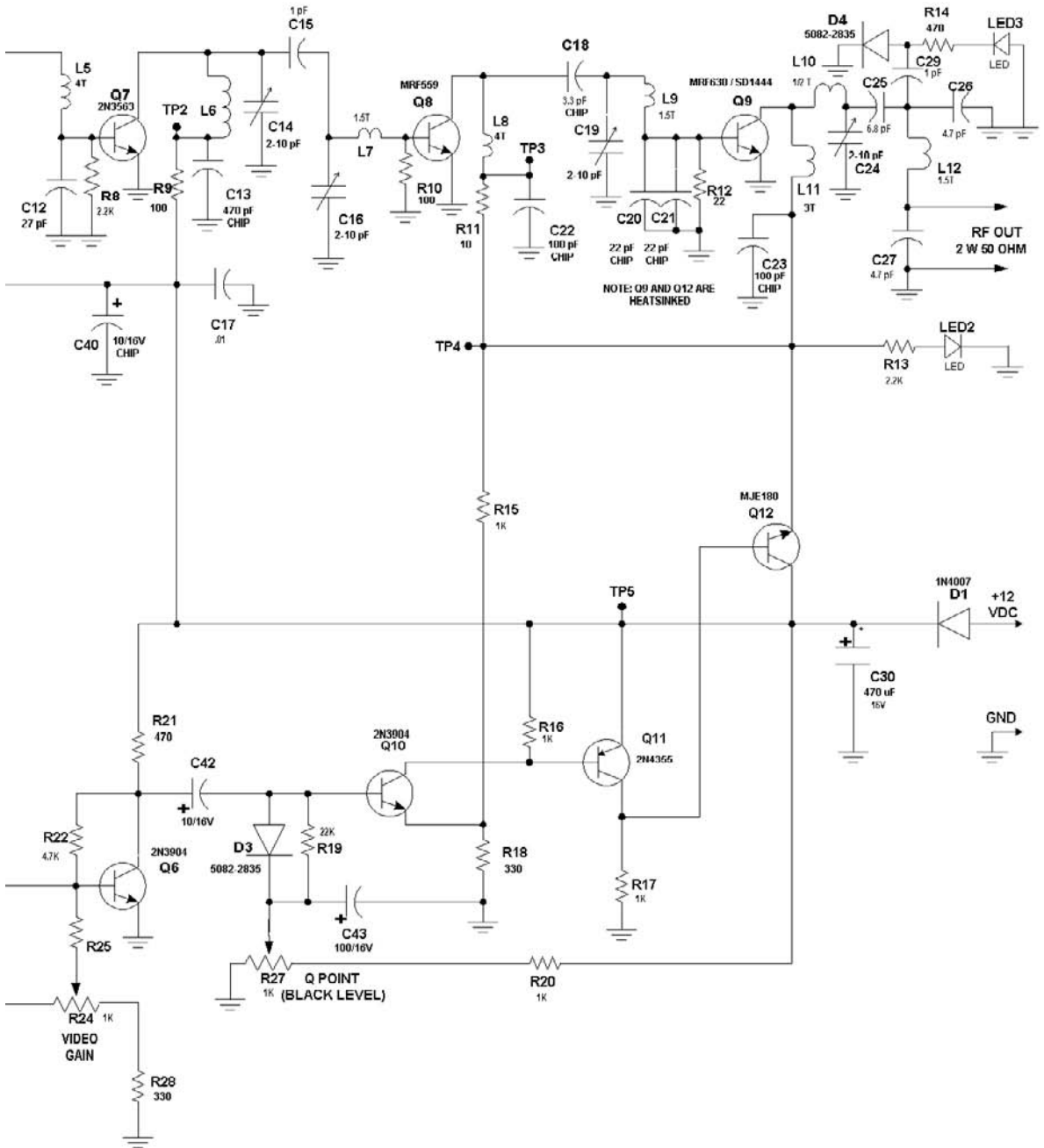

Figure 12-1
Schematic of the ATV12-440 MKII 2W ATV Transmitter

of about 28 is obtained; however, preemphasis is necessary, which requires increasing the gain by 6 dB/octave above 2100 Hz. This is done by splitting the feedback resistor network into two resistors: R35 and R36. C33, along with the values of R35 and R36, acts as an RC filter network, and above about 2100 Hz, C31 bypasses part

2-Watt TV Transmitter for R/C and Amateur TV for 440 MHz



of the feedback signal, causing a rise in gain of the Q4 stage. This provides the necessary high-frequency boost. Audio from Q4 is fed to varactor diode D2 via C34 and R38. D2 is part of the frequency-determining network of 4.5-MHz subcarrier oscillator FET Q5. D2, C35, C36, C37, C38, and L13 make up the 4.5-MHz tuned

circuit. FET Q5 is used as a Colpitts oscillator, with R40 and the tuned circuit components, and bias is provided by 5-volt regulator IC1 and associated bypass capacitor C39. This provides a stable voltage to the audio section to reduce drift with supply voltage changes. J2 is an onboard jumper that can be removed to disable the sound section in applications for which no audio is required. This can be replaced with an SPST switch if desired. Audio voltage on D2 changes its capacitance, resulting in frequency modulation of the subcarrier. C36 sets the 4.5-MHz sound subcarrier frequency. For the PAL operation, the sound subcarrier frequency can be shifted to 5.5 or 6 MHz by removing about 2 to 3 turns from L13 and then adjusting C36 for the proper frequency. Subcarrier from Q5 is fed into the video modulator via the wiper on potentiometer R40, which serves as a subcarrier level adjustment. R41 and C41 couple this subcarrier to video amplifier Q6, where it is mixed with the input video. The setting of R40 sets the subcarrier level. C39 is a decoupling capacitor. R34, R35, R36, and R37 bias audio amplifier Q5. Chip C32 prevents RF from the transmitter from getting into the audio signal.

Q3 and associated components R29, R30, and R31 and green indicator LED1 form a keying circuit for the transmitter and any connected video camera. When the key line connected to R30 is grounded, Q3 conducts and supplies DC to R4 and the crystal oscillator stage and to the camera power lead. LED1 glows green under these conditions, indicating an ON condition. When the key line is disconnected from ground, Q3 is cut off, which removes DC from the oscillator, cutting off the transmitter, camera, and the indicator LED1. This feature is handy in remote control applications. Up to 200 mA of DC is available for the camera. The keying line, camera power, and video and audio inputs are all brought to an onboard eight-pin header for use with a Molex or similar connector with 0.1-inch pin spacing. This allows for easy connections. The header can be omitted if plain wiring is preferred.

The entire transmitter will draw around 6–8 watts of DC power at 13.8 volts and will output typically 2–3 watts peak power on sync tips. This means that around 5 watts of heat may be generated. Because this transmitter is physically small, some attention should be given to thermal considerations. The included heatsink is adequate for intermittent (3 minutes on, 3 minutes off) ham use and normal tuneup and testing; however, the transmitter will run cooler if additional heatsinking is provided. The G10 shield can be replaced with a metal (copper or brass) plate, which can be fastened to a chassis or a radiator fin. The DC supply should be clean and stable because any noise or ripple in the supply voltage can modulate the RF carrier and/or shift the carrier level, causing sync clipping or interference in the received video. Less than 50 mV of ripple and noise is necessary, less being desirable. This should not present any problems because most decent-quality supplies easily meet these specifications.

Construction Procedures

The construction and testing of this transmitter requires working in the UHF part of the frequency spectrum. Use only the exact parts specified, with no substitutions. A kit of parts, together with a drilled and etched PC board, is available from the source specified at the end of this chapter and is highly recommended because some of these parts may be difficult to obtain at reasonable cost in small quantities. Again, make no substitutions, and do not use “generic” service-grade transistors sold for servicing and replacement use (ECG, SK, NTE, etc.) because these parts may not work properly. Before beginning construction, familiarize yourself with the PC

board and the layout. Note that some holes are larger than others and use them as landmarks. Read and understand the circuit description; it makes things easier when you understand what is going on. Carefully identify all parts against the parts list. Use good lighting while assembling the transmitter. A magnifier is necessary to see some color codes with any certainty. Check any dubious items with a VOM to be sure. If you are not sure about a part, use the process of elimination to help narrow it down. It is helpful to first insert larger parts, such as trimmer caps and potentiometers, to serve as landmarks. The larger holes on the board are for the trimmers and pots. Two large holes are located near the left side for Q8 and Q9. A shield and heat-sink partition runs parallel to and 1.1 inches (2.8 mm) from the left side of the board. Note that all trimmer caps and grounded leads of resistors must be soldered on both sides of board. This step is essential for good RF grounding. Also note that Q9 must have its case soldered to the top of the board. Certain parts, such as chip capacitors and Q8, are mounted under the board (see Figures 12-2 and 12-3).

Except where access may be difficult later, *do not* solder any connections until as many components as possible are inserted. All coils are installed after components are inserted, and this is the only exception. *All* parts are mounted tight and close to the board, with no exceptions. *Zero* lead length is a must in the RF circuits. You should use only rosin core solder, with low residue preferred. *Do not* use acid core or any paste fluxes. A hot, small pencil iron is best. (See the Appendix for chip capacitor mounting details.) Remember that you are working at UHF frequencies, and lead lengths are critical. They should ideally be *zero*.

Begin construction by inserting all trimmer capacitors in the PC board. Make sure that the correct values are inserted. Note the large holes for Q8 and Q9. Orient the

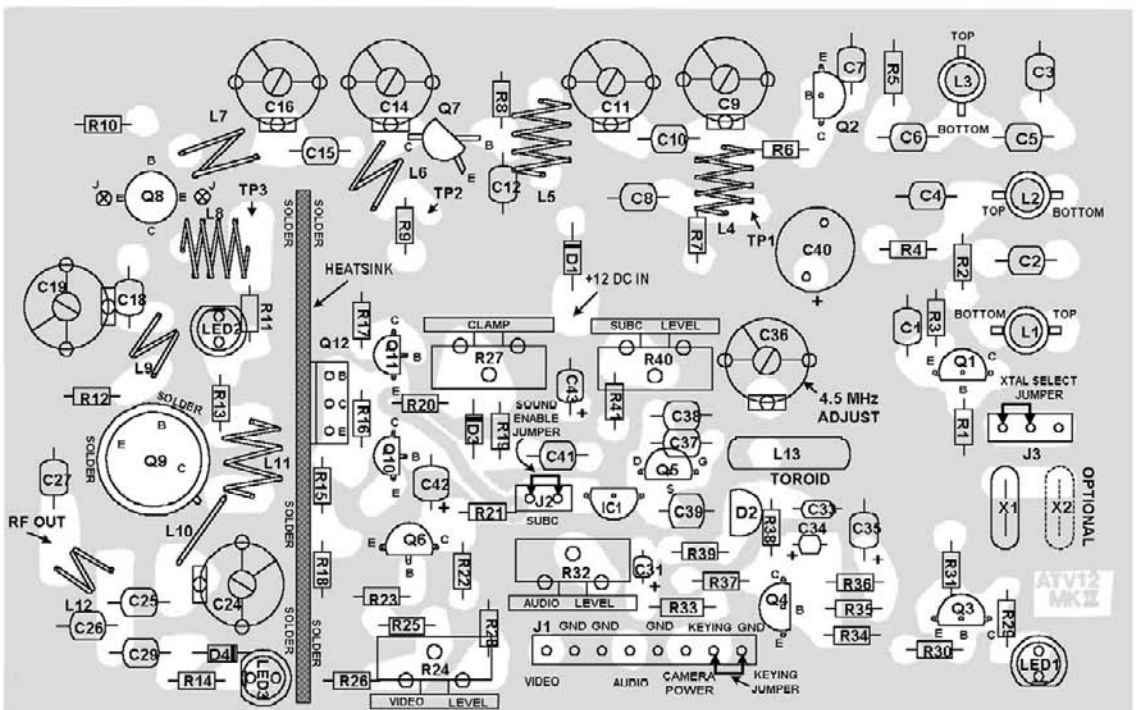

Figure 12-2
Parts Placement of the ATV12-440 MKII Component Side

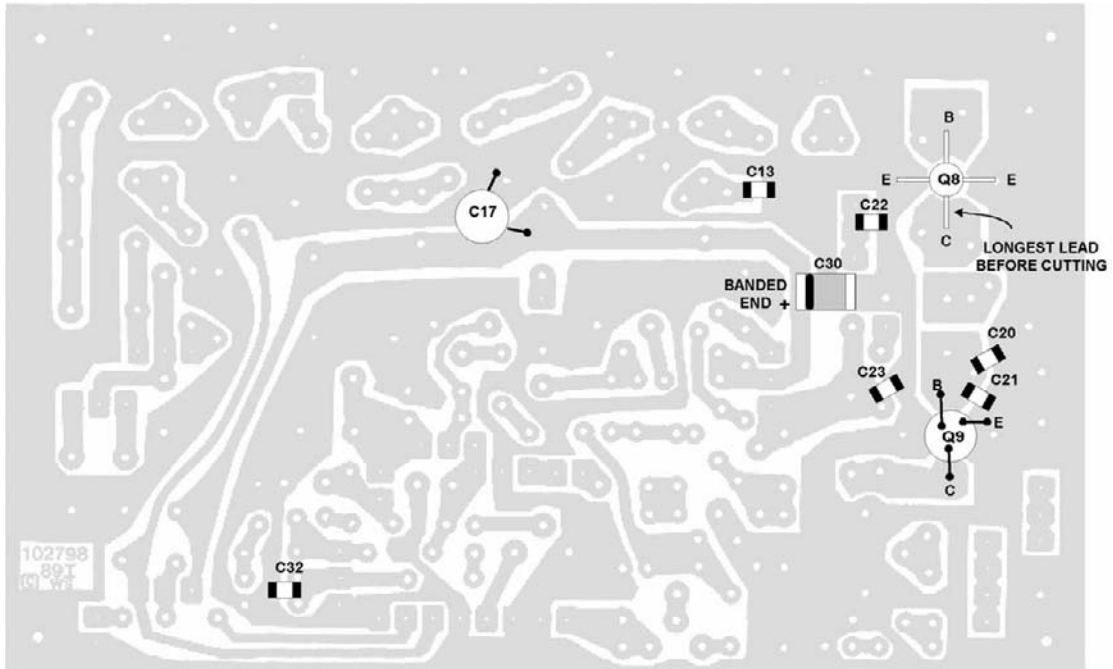

Figure 12-3
Parts Placement of the ATV12-440 MKII Solder Side

board so that these holes are near the left side. After making sure the correct parts are installed, solder the side terminals of trimmers to the top side of the PC board. Be careful not to melt the plastic. Install pots R24, R27, R32, and R40. Do not solder the bottom at this time. After carefully identifying them, mount all resistors. Solder only the top of the board, where the resistor leads pass through the ground foil. Solder as many as you can. Do not solder the bottom yet. Make sure to solder the top trace, with R20 and R21 passing through it because this trace is used to supply DC voltage to the video amplifier and audio subcarrier generator. Next, install capacitors. Any that have preformed leads should have these leads straightened with pliers to fit as close to the board as possible. Watch the polarity of all electrolytic capacitors. Do not install chip capacitors until a later step. Identify and install all transistors, except the MRF559 (Q8), MRF630 (Q9), and MJE180 (Q12), which will be installed later. *Watch for correct orientation.* All other transistors should be 1/8 inch from the surface of the board. Solder the emitter leads of Q4 and Q5 to the top of the PC board, where they pass through the ground plane foil. Install the 5-volt regulator IC1. Install D1, D2, D3, and D4. Install the LEDs, making sure to observe correct polarity. (Flat side is negative.) Note that LED1 and 2 (green and yellow) have their flat sides grounded, whereas LED3 (red) has its flat side connected to R14.

Watch polarity on all diodes and LEDs. Using scissors, trim the crystal leads to 3/16ths inch and install. *Do not* use diagonal cutters because the shockwave can damage the crystal. Solder a short wire to the top of the crystal enclosure and run this lead to the ground. Use resistor lead clippings or another wire scrap. Carefully check all work done so far for accuracy and orientation. Now trim all component leads to length, if not done yet, and solder all bottom connections made so far. Do not plug up any unused holes yet. Mount Q12, with the metallic side down, to the

heatsink. Do not forget to install a mica insulator between them. Mount with a 4-40 by 1/2-inch screw, lockwasher, and nut; screw head faces the left side of the board. Correct orientation is such that the transistor is closer to the right side of the heatsink when facing you, and the manufacturer's identification is visible. It may be necessary to trim excess mica insulator. Do not overtighten, and make sure that no leads of Q12 show any electrical continuity to the heatsink. Install the heatsink and Q12 vertically on the PC board. The leads of Q12 should fit into the holes in the PC board, and the heatsink should have its edge about 1/16ths inch from the edge of the PC board. Make sure that the heatsink is vertical and positioned properly (see Figure 12-2). Q12 should be on the side of the heatsink facing the right side of the PC board. Solder as much of the seam on both sides of the heatsink as possible. Use a hot, fine-tipped iron. Finally, do not forget to solder the leads of Q12 under the board.

Carefully fabricate all coils and install them in the PC board (see Figure 12-4). Be sure that no turns short together on L4 through L12 and that L1 has its bottom turn connected to the junction of C2 and collector of Q1, L2 has its bottom turn connected to the junction of C2/C3, and L3 has its bottom turn connected to the junction of C5/C6. Use an 8-32 screw to hold the coils L1, L2, and L3 during installation. After installing coils, remove the screw and insert the threaded slugs fully into the coils. Use the coil-winding table for information. It may be wise to add an extra turn to toroid L13 to allow for final "tweaking" if needed. Toroid L13 will then have an extra turn, which may need to be removed if the subcarrier frequency is too low and 4.5 MHz cannot be reached; however, it is easier to remove a turn later than to add one. This requirement will be determined during the final test procedure. (Information for PAL operation is given on page 136.)

Install C13 (470 pf chip) (see Figure 12-3). Install C22, C23, C32 (100 pf chips), and C30 (10 uf chip tantalum cap) on the the *underside* of the PC board. *Watch the polarity* of C30. Band is on the positive side. Chip capacitors C20 and C21 (22 pf chips) will be installed in a later step. Install Q8; the long lead is the collector. Trim leads to length and install them such that Q8 has its manufacturer's identification in the hole and visible from the bottom side of the board. The plane of Q8 leads should be flush with the bottom of the PC board. Install Q9. Pass the three leads through the 1/4-inch hole and orient Q7 as shown in the parts placement diagram. The case of Q7 should be tight against the ground plane foil. Bend the three leads on the bottom so they are against the correct PC board pads and solder. *Ignore the two holes near the 1/4-inch hole for Q9*; all three leads pass through the 1/4-inch hole (no, the board isn't wrong; *Q9 has a reversed pin layout*). Next, solder the case of Q9 to the ground plane to ensure good grounding and heatsinking. Install 22 pf chip capacitors C20 and C21 between the base of Q9 and the ground. Carefully inspect all work so far. Look for solder shorts, poor joints, missing parts, incorrect parts placement, and so forth. You are ready to check out the board once everything is satisfactory.

Tuneup Procedure

The following equipment is required:

- VOM analog preferable 20K/volt
- Power supply 13.2 volts regulated, 1.0 ampere or better
- Ammeter 0–1 ampere (not required if power supply has metering)
- Test leads, RF cables, and fittings as needed
- Video and audio source (VCR, camera, camcorder, etc.)

Figure 12-4

Coil Winding

Information for the
ATV12-440 MKII

L1, L2, & L3

Wind coils using #22 enamelled wire. Use 8-32 machine screw as a mandrel, winding wire in screw threads to form coil.
Form leads, as shown, remove enamel and tin before installation.
Install in PC board using screw as holding tool. Remove screw and insert slugs.

- L1 = 7.5 Turns
- L2 = 3.5 Turns
- L3 = 4.5 Turns

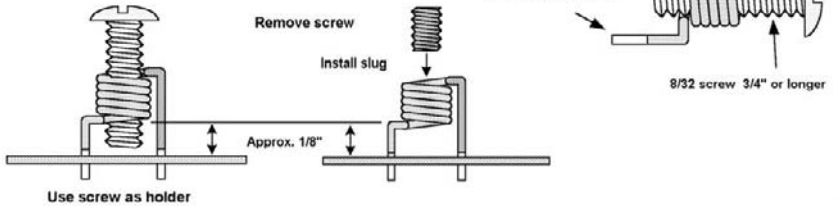

L4, L5, L6, L7, L8, L9, L11, & L12

Wind coils using #22 bare. Use 8-32 machine screw as a mandrel, winding wire in screw threads.

Form leads, as shown, install in PC board using screw as holding tool. Remove screw. No slugs are used.

Install in PC board as shown.

- L4, L5, L8 = 4.0 Turns
- L11 = 3.0 Turns

- L6, L7, L9, L12 = 1.5 Turns

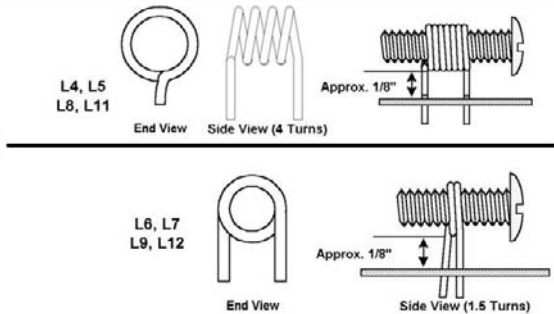

L10

L10 = 0.5 Turn
Semicircle

Use #22 Bare wire
Form inductor as shown

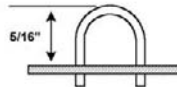

L13 Toroid

14 turns #22 gauge enamelled wire on 0.375" dia. Ferroxcube toroid 3E2A material. Strip insulation, tin, and mount in PC board.

L13 = 14 Turns #22 enamelled
on toroidal core

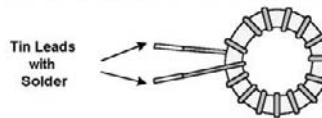

- A) Each pass through hole counts as 1 turn.
- B) Remove enamel and tin leads as shown.
- C) Install in PC board tight to surface, per layout.

The following equipment is desirable but not necessary:

- 50-ohm dummy load, preferably with meter, good to 500 MHz
- Frequency counter good to 500 MHz
- Variable power supply 13.2 volts regulated 0–15 volts at 1 ampere
- Receiving setup for ATV reception

Refer to the schematic and PC layout as required. Preset all trimmer capacitors and potentiometers as follows:

- | | | |
|----------|----------|----------|
| C9: 40% | C19: 20% | R27: 50% |
| C11: 70% | C29: 25% | R32: 25% |
| C14: 10% | C36: 50% | R40: 25% |
| C16: 25% | R24: 50% | |

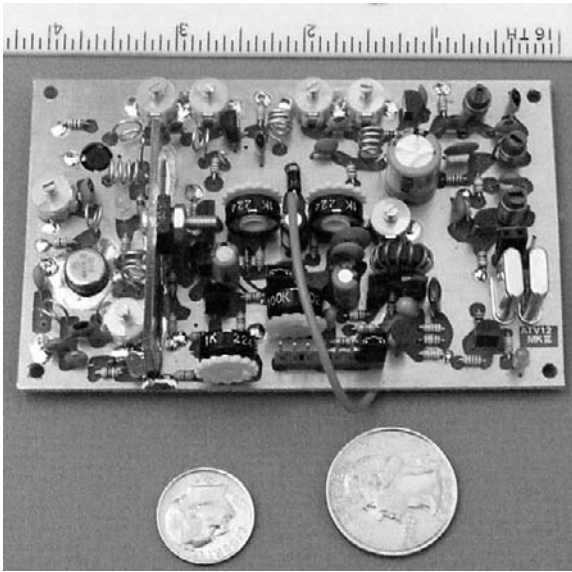

Figure 12-5
Photo of the Completed PC Board of the ATV12-440 MKII



Figure 12-6
Solder Side of the PC Board for the ATV12-440 MKII

These percentages are the amount by which the plates of the trimmer mechanically overlap with respect to full setting, or percent rotation in the case of potentiometers. Perform the following steps in order, and do not proceed to the next step unless you get specified results.

1. Connect a 0- to 1-ampere meter in series with the positive supply lead if your DC supply has no built in ammeter that can read currents between 0.1 and 1 ampere. Connect the transmitter output to the dummy load and RF indicator. *Do not use an antenna.* If you do not have a suitable dummy load, connect two 100-ohm 0.5-watt *carbon* resistors in parallel (to make up a 50-ohm 1-watt load) across the RF output pad on the circuit board and ground. LED3

Figure 12-7

Component Side
of the PC Board
for the ATV12-440
MKII



will give a good indication of RF output. At proper output, it will glow brightly. Keep the 100-ohm resistor leads less than 1/4-inch long to minimize stray inductance and circuit detuning.

2. Connect the 13.2-volt DC supply to the transmitter. Make sure the keying line from R30 is grounded. You may use a jumper on the pins of an eight-lead header to do this. The LED1 green LED should light. Remove the jumper or momentarily disconnect the keying line from the ground and confirm that LED1 goes out. Make sure that jumper J3 is on the three-pin header selecting the 439.25-MHz crystal. Make sure that jumper J2 is installed to activate the audio section. Note current consumption, which should be 30–70 mA. Connect the positive lead of the VOM to the emitter of Q12 (TP4) and the negative lead to the ground. Verify that R27 can vary this voltage from less than 2 to more than 11 volts. Observe that the yellow LED2 lights and varies in brightness with the setting of R2Adjust R27 for maximum voltage at the emitter of Q1This will also be maximum LED2 brightness.
3. Connect the VOM across R7 (TP1) and the positive supply TP5 Peak L1, L2, and L3 for maximum DC voltage reading, about 2 volts typically.
4. Connect the VOM across R9 (TP2) and the positive supply TP5 Peak C9 and C11 for maximum DC volts, 1.5–2.2 volts is typical. If the voltage is low, leave the VOM connected and try repeaking L1, L2, and LIf the VOM is still below 1.5 volts, go back and check for proper component placement.
5. Connect the VOM across R11 (TP3) and modulator output TP4 Peak C14 and C16 for maximum DC volts, 1–2 volts is typical. If less than 1 volt, check the dimensions of L6 and LIf the voltage is still low, leave the VOM connected and repeak all previous adjustments to maximize the meter reading. If the VOM reading is still low after peaking all adjustments, go back and check for proper component placement. LED3 may start to glow red during this step, which is a good sign.
6. Watch the red LED (LED3) and slowly adjust C19 for any detectable glow or any increase in power supply current. When any detectable glow is noticed,

peak C19 and C29 for maximum glow, then readjust C14 and C16 as needed. Watch the ammeter in the supply lead. As LED3 brightens, the power supply current will increase to around 400–600 mA. The dummy load should indicate RF power, or if the 100-ohm resistors are used instead, they will get rather warm. This indicates the presence of RF output and is normal.

7. Next adjust C19 and C29 again for maximum RF output. At least 1.8 and typically 2.5 watts should be obtained. Repeat the tuneup steps as required for maximum RF power output. Q9 and Q12 will normally run quite warm after a few minutes.
8. Reduce the power supply voltage and note the voltage at which RF output drops out. This should be typically less than 10 volts. If not, retune C9, C11, C14, C16, C19, and C29 as needed. Restore 13.2 volts and see if at least 1.8-watt output is obtained. Retune as required. Expect to experiment a little because adjustments may interact somewhat, which is normal. Your final trimmer settings should not be radically different from the presets if you have made the inductors correctly and the chip capacitors are properly installed.
9. When you are done with RF alignment, adjust the clamp level control R27 for about 75 percent of full RF output. The yellow and red LEDs will dim slightly, but this is acceptable. If you have a frequency counter, connect it to the emitter of Q12 (TP4). You should see a reading of around 4.5 MHz. Adjust C36 for a reading of 4.495–4.505 MHz. If you are too high or low at the limits of adjustment of C36, add or subtract a turn from L13 as required. If you have no counter, adjust C36 for best audio while monitoring the transmitted signal on a receiver. (Information for PAL operation is given on page 136.)
10. Place a drop of Duco cement or clear lacquer on L1, L2, L3, and toroid L13 after tuneup is complete. This step provides mechanical stability and anchors the slugs of L1, L2, and L3.
11. Apply video and audio to the transmitter and adjust R24 and R27 for best picture. R24 affects contrast, whereas C27 affects brightness and stability. Correct adjustment yields a good, stable picture, with no blocked-up highlights or lowlights, and freedom from rolling, tearing, or other instabilities. Make sure the receiver is not overloaded and situated at least 10 feet from the transmitter. Audio gain is set with R3. If sound bars are noticed in the picture, adjust R40 to eliminate them. Audio buzz may be pronounced if video gain R24 or clamp R27 are set too high.

If continuous operation is contemplated, keep the supply voltage between 12.0–13.2 volts, unless additional heatsinking is provided for Q9 and Q12. Do not exceed 15 volts or you may damage the RF and modulator circuitry. For low-voltage applications (9.6-volt battery supply), it would be best to repeak all adjustments at this voltage after initial tuneup has been done. Battery voltage falloff is less well tolerated at this low-supply voltage because the design has been optimized for 11- to 15-volt supply voltages. A properly tuned transmitter might function typically down to about 7.2 volts, but there is no guarantee of this, and at best RF power output will be around 0.5 watt at 7.2 volts. (Would you expect 120-volt AC equipment to work properly with a 72-volt AC supply?) The transmitter is safe from any damage at this supply voltage. We cannot guarantee operation at this low voltage, but it is possible, and the information herein is presented for those who wish to experiment.

Figure 12-8

Photo of the Completed ATV12-440 MKII in a Proper Metal Case

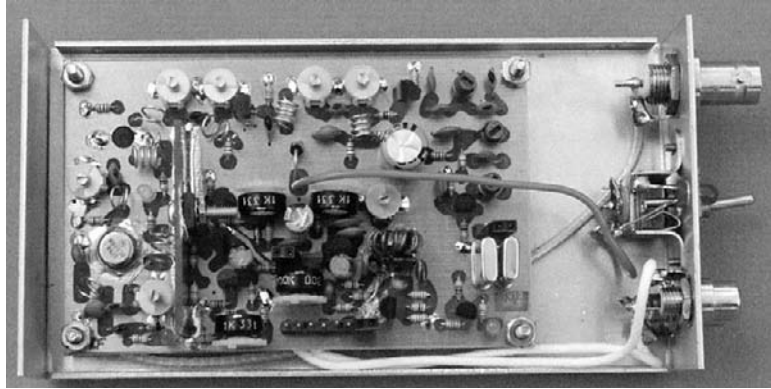

Parts List

Resistors 1/8W 5% (unless spec.)

R1, R15, R16, R17, R20, R23, R25, R31	1.0 K ohm
R2	3.3 K ohm
R3, R18, R26	330 ohm
R4, R7, R9, R10	100 ohm
R5, R8, R13, R29, R30	2.2 K ohm
R6, R11	10 ohm
R12	22 ohm
R14, R21	470 ohm
R19	22K ohm
R22, R33, R37	4.7 K ohm
R24, R27, R40	PT10 pot, 1.0 K ohm
R28	82 ohm
R32	PT10 pot, 100 K ohm
R34	33 K ohm
R35, R36, R39	100 K ohm
R38, R41	10 K ohm

Semiconductors

D1	1N4007
D2	MV2112
D3, D4	5082-2835
LED1	LED, green
LED2	LED, yellow
LED3	LED, red
Q1, Q2, Q7	2N3563
Q3, Q11	2N4355

2-Watt TV Transmitter for R/C and Amateur TV for 440 MHz

Semiconductors (cont.)

Q4	2N3565
Q5	MPF102
Q6, Q10	2N3904
Q8	MRF559
Q9	MRF630 or SD1444
Q12	MJE180
IC1	LM78L05

Capacitors

C1, C7	56 pf NPO ceramic
C2	39 pf NPO ceramic
C3	18 pf NPO ceramic
C4, C17, C41	.01 disc 50V GMV
C5, C18	3.3 pf NPO ceramic
C6	33 pf NPO ceramic
C8	470 pf disc ceramic
C9, C11, C14, C16, C19, C24	2-10 pf, 7.5 mm trimmer
C10	2.2 pf NPO ceramic
C12	27 pf NPO ceramic
C13	470 pf chip 60 × 120
C15, C29	1.0 pf NPO ceramic
C20, C21	22 pf chip 60 × 120
C22, C23, C32	100 pf chip 60 × 120
C25	6.8 pf NPO ceramic
C26, C27	4.7 pf NPO ceramic
C30	10 uf 16V chip tant.
C31, C34	0.47 or 1.0 mf 35V tant.
C33	.0022 uf mylar
C35	.001 uf mylar
C36	2-20 pf, 7.5 mm trimmer
C37	68 pf NPO ceramic
C38	120 pf NPO ceramic
C39, C42	10 uf 16V elec
C40	470 uf 16V elec
C43	100 uf 16V elec
C28	Not used

Coils and Chokes

1 ea	Core, toroidal, 266T125-4C4
24"	#22 enamelled wire
24"	#22 tinned wire

Build Your Own Low-Power Transmitters: Projects for the Electronics Experimenter

Coils and Chokes (cont.)	
3 ea	Cambion blue slug
1 ea	8-32 × 1" screw for coil-winding form

Miscellaneous	
1 ea	Crystal, 439.25 MHz (54.90625 MHz third OT)
1 ea	PC board
1 ea	Heatsink and shield (G-10 material)
1 ea	4-40 × 1/2 BHMS
1 ea	#4 lockwasher
1 ea	#4 nut
1 ea	TO-220 mica insulator
1 ea	8 pin header 0.1" spacing
1 ea	3 pin header 0.1" spacing
1 ea	2 pin header 0.1" spacing
3 ea	shunts for header

A kit of parts to build the transmitter, consisting of complete documentation, a drilled and etched printed circuit board and all parts that mount on the board, is available from the following supplier:

North Country Radio
P.O. Box 53, Wykagyl Station
New Rochelle, NY 10804-0053
E-mail: support@northcountryradio.com
Website: www.northcountryradio.com

Check their website for current price and an order form. A suitable two-tone aluminum case, a hardware kit, and a tuned “rubber ducky” antenna are also available from North Country Radio.

13. 1-Watt TV Transmitters for 902-928 MHz and 1240-1300 MHz

These 1-watt ATV transmitters were developed from a design originally described by the authors in an article in the November/December 1994 issue of *QST*. The original design was for 902–928 MHz amateur band use. Since that time, many of these transmitters have been successfully used in many applications. The article described the 902–928 MHz version, and later the version for the 23-cm amateur band at 1240–1300 MHz was developed from it. These later versions are the result of many refinements. As a result, they are somewhat different in circuitry from the original, although they use a similar mechanical layout. Like the transmitter previously described in Chapter 12, if you have seen a similar 900-MHz transmitter in books or previously published articles, or have previously constructed one, you will note the changes and differences from the original unit. The 1300-MHz version, like the 900-MHz version, incorporates revisions like those in the 440-MHz model described in Chapter 12. It has an improved video modulator, remote keying, a better camera interface, improved audio, and a better adjustable video clamping circuit. As a result, the transmitter performs better during supply voltage falloff when batteries are used. Three LED indicators have been added to facilitate setup and to provide a visual indication of circuit operation. Setup is also easier with simpler adjustments.

General Description

This transmitter generates a complete NTSC video signal and a 4.5-MHz FM sound subcarrier, modulated on a UHF carrier. This UHF signal can be received on any standard TV receiver fitted with a suitable RF downconverter capable of tuning the 902–928 MHz or the 1240–1300 MHz amateur band. Standard TV receivers are not capable of tuning these higher frequencies, so a converter is needed. The small board size (2.5 by 4 inches) is comparable to many small PC board cameras and is small enough for the same applications as the 440-MHz unit described in Chapter 12. Operation is similarly possible from nominal 9- to 14.4-volt power supplies, with minor adjustments in video drive. Lead acid, nicad, or alkaline power packs may be used. Less than 8 or more than 15 volts is not recommended. Power output is typically from 0.3–1.5 watts PEP over this range. The transmitter requires standard NTSC or PAL video. The transmitter audio can also be retuned for a 5.5-MHz sound subcarrier used by the PAL system. The video input requirement is standard 1-volt point-to-point 75 ohms, negative sync. Audio inputs from 100 mV to 1 volt can be accommodated.

Note that a valid amateur's license permitting operation at 900 and 1300 MHz is a requirement for operation of this device. In the United States, this is a Technician Class (code-free) license, so if you can build this transmitter, you should easily be

able to pass the required examination. *Operation of this device on commercial TV frequencies is illegal in the United States.* Although this transmitter may be used for such applications in export situations, in the United States it is intended for amateur use by legally licensed amateurs and for no other purpose.

Circuit Operation

In this discussion, the transmitter schematic shown in Figure 13-1 is repeatedly referred to. Therefore, it will help if you familiarize yourself with the schematic before reading further. Some ham radio experience and some familiarity with RF circuits and transmitters is assumed. If you are a little unfamiliar with these areas, some study of the appropriate material in a reference such as the *ARRL Handbook for Radio Amateurs* or *RSGB Handbook* is highly recommended. This background will also help ensure success with this project. Because many of the circuits are similar or identical to those used in the 440-MHz version in Chapter 12, we limit our detailed discussion to those circuits that differ. The reader may wish to read Chapter 12 before reading this chapter because many cross-references are made.

Except for a few minor details and value differences in the RF-tuned circuits, the transmitters are basically identical, and they can be difficult to tell apart at first glance. Some of the 900- and 1300-MHz tuned elements and matching network components are integrated into the PC boards as microstrip elements. The schematic is very similar to that of the 440-MHz transmitter in Chapter 12. Parts designations for these higher-frequency versions were made to match the corresponding parts in the 440-MHz unit. Hence a little “jumping around” may be noticed with regard to the parts designations not following an expected consecutive order. Where they are different, values for 900 and 1300 MHz are shown as two values with a fraction bar between them (i.e., 900/1300 MHz, 100/33 ohms, etc.). The first number is the 900-MHz part value, and the second is the 1300-MHz part value.

Referring to the schematic, Q1 is a crystal-controlled oscillator using one or two crystals (57 or 53 MHz for X16 and X24 multiplication factor as necessary) and an onboard jumper to select the desired crystal. This allows easy frequency change. For single-channel use, only one crystal is needed. These units differ in the use of PIN diodes to switch the crystals rather than direct switching. Although operation on 440 MHz is generally simplex fixed frequency, repeaters are commonly used on these higher bands. The use of DC crystal switching allows easier switching between repeater and simplex modes because only DC levels are switched; however, an onboard jumper is still used, and a switch can be connected in place of the jumper if desired. This feature could have been incorporated into the 440-MHz design as well, but these are later designs, and the PIN diode switching was added even though it was not incorporated into the 440-MHz design. Otherwise, oscillator circuit operation is identical to the 440-MHz unit. R1, R2, and R44 feed bias to the base of oscillator stage Q1. The crystal selector jumper or switch selects R2 or R44. The current flow forward biases the PIN diode associated with the selected crystal, causing it to appear like a low-value resistance of several ohms. The selected crystal effectively appears in series with the base of Q1 and ground. For RF, Q1 is a common base oscillator circuit.

At the series-resonant frequency of the crystal, the base of Q1 is nearly grounded. L1 and C2 are tuned somewhat above resonance, causing oscillation at the crystal frequency. The signal generated contains harmonics. Filters L2, C3, C5, L3, C6, and C7 couple the second harmonic to doubler/tripler stage Q2. This stage doubles or triples the signal frequency to 225–235 or 310–325 MHz, respectively. The output at

the collector of doubler/tripler stage Q2 contains several frequencies in addition to the desired second or third harmonic of the input frequency. Filter C44, C45, L4, C46, L14, and C47 is tuned to the desired frequency, which is approximately 230 MHz in the 900-MHz version, and around 320 MHz in the 1300-MHz version. TP1 is used in tuneup, and C8 is a bypass capacitor, R7 a decoupling resistor. The output of the filter network feeds the base of doubler Q13. R42 is a bias return for Q13. The output of this doubler appears at the collector of Q13 and contains fundamental, the desired second harmonic, and higher harmonics. The output of this doubler is either 460 MHz or 640 MHz approximately, for 900 and 1300 MHz, respectively. Filters C9, L15, C10, L5, C11, and C12 suppress all other frequencies except the second harmonic and match the input of the next stage, Q7, another doubler. Q7 doubles this signal to the final output frequency in the 900- or 1300-MHz range to the final 902–928 or 1240–1300 MHz output frequencies, respectively. At the output of Q7, about 20–50 mW of RF energy is present. In addition, the transistors used here are rated for 900-MHz service. Because they are not internally matched for optimum 900-MHz use, it was thought that they would have a chance of working somewhat satisfactorily at 1300 MHz, but with somewhat reduced gain.

Extrapolation of the manufacturers' data sheets based on experience with RF devices and application of basic principles gave us an idea of what input and output impedances to expect. Based on these parameters, a trial 1300-MHz RF power amplifier could be built and tested. Tests and consultation with the manufacturers' applications departments confirmed this fact, and using these extrapolated parameters, a design was created that worked well the first time it was tried. Driver Q8 is fed from Q7 via microstrip transformer L7 A and B, two small lengths of microstripline that are part of the PC board. The primary L7A and LB is tuned by C14, whereas the secondary L7B is tuned by C16 and is part of matching network C17, L7B, C49, and C50. R10 provides base bias for Q8. The output of Q8 is fed by RF choke L8 and coupling capacitor C18 to matching network L9, C19, C20, and C21. Note that C19 is not used on the 1300-MHz version and the tuning is fixed and broadband and needs no tuning adjustment. R12 is a bias resistor for Q9. The output of Q9 is fed to matching network L10 and C24. C25 is a DC blocking capacitor, and C26, C27, and L12 act as a lowpass filter. C26, C27, and L12 are not used on the 1300-MHz version because second harmonic energy at 2600 MHz is very low. C29, D4, R14, and LED3 make up an LED RF output indicator, and enough output from the detector is obtained to light up LED3, indicating the presence of RF output.

Although 1.5 and typically 1.7–2 watts RF can be obtained at 900 MHz, 1.1 watts is typical at 1300 MHz, with one test unit delivering slightly more than 1.5 watts output. This output is not bad, considering that the transistors are not characterized for this frequency. This result was borne out in field tests in which 100 of these units were built and worked consistently well. No low-cost transistors characterized at 1300 MHz are available because no commercial services exist near this frequency. 1300 MHz is “out in the boondocks” of the radio spectrum. The biggest problem we have encountered is that the final amplifier transistor (MRF557) tends to run warm, causing a slump of about 1 dB in output power. This reaction is caused by the small size of the transistor and the limited ability to attach a really effective heatsink because of package limitations, but 1 watt is still respectable on 1300 MHz. Very high-gain antennas are easily made for this frequency range, and the transmitter is small enough to be antenna mounted, eliminating feedline loss problems common at this frequency. A 20 dB Yagi is quite small at 1300 MHz. This yields a 100-watt effective radiated power (ERP) signal with a 1-watt transmitter. Therefore, the 1-watt output is satisfactory considering the low cost of the transistors used.

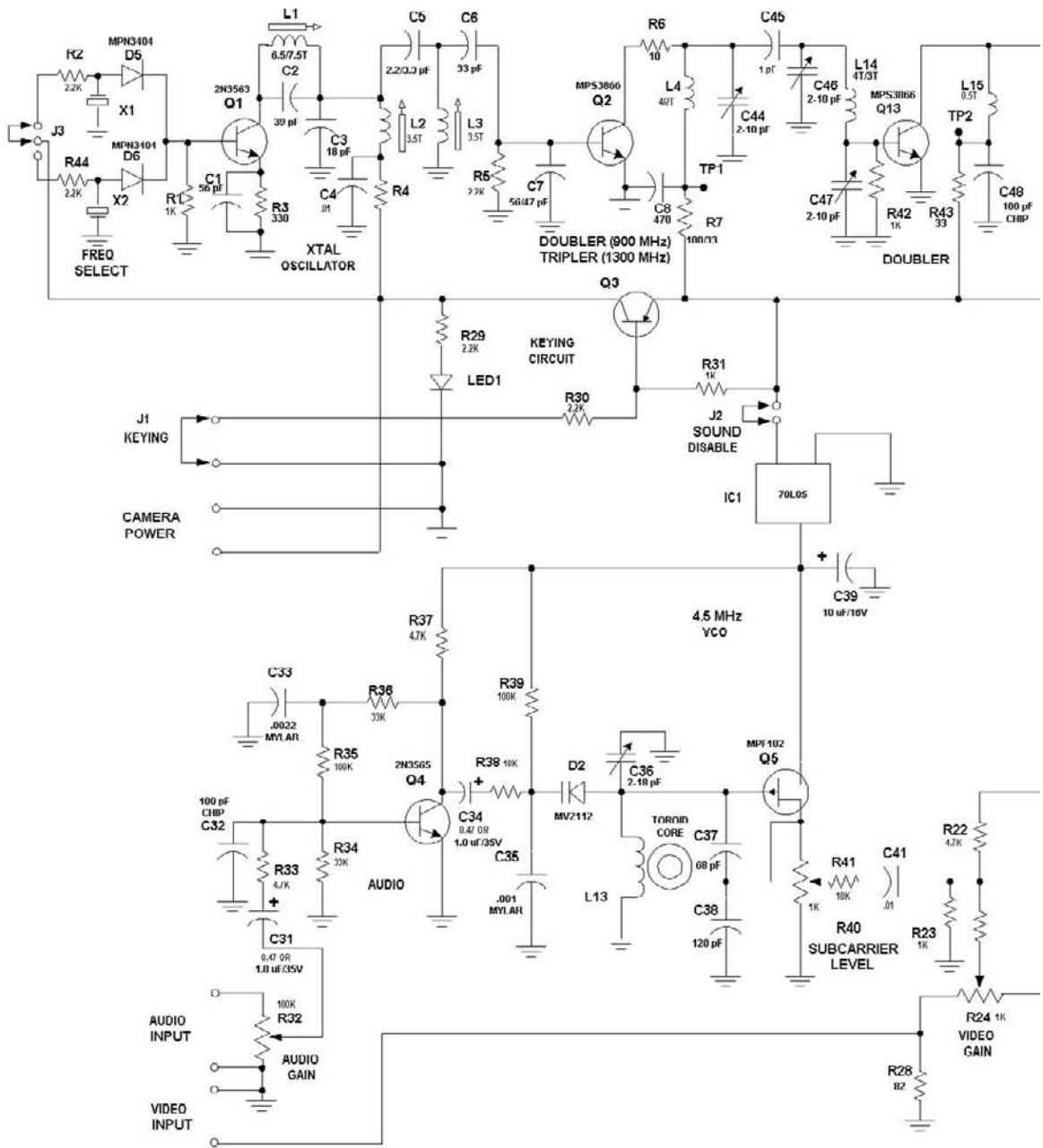
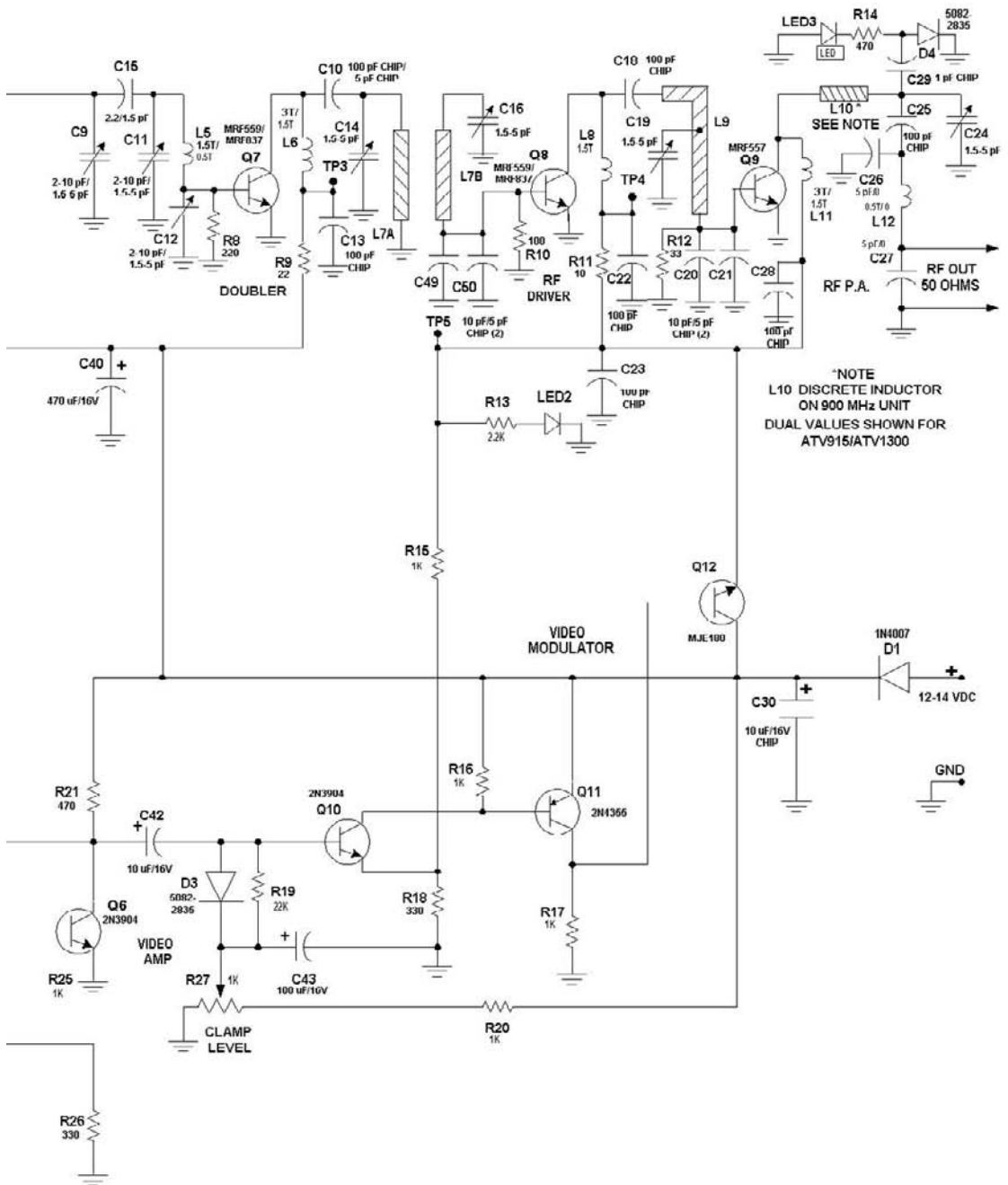

Figure 13-1
Schematic of the 900/1300MHz ATV Transmitters

Video-modulated DC is supplied to Q8 and Q9 via RF chokes L8 and L11. These are only a few turns of wire (1.5–3 turns) because very little inductance is needed for a good RF choke at these high frequencies. R13 and LED2, a yellow LED, serve as a voltage indicator and are used to set up the transmitter and as a modulation indicator. C23 and C49 are bypass capacitors. Chip capacitors are necessary at these frequencies for really effective bypassing. R11 and C22 are also

1-Watt TV Transmitters for 902-928 MHz and 1240-1300 MHz



connected to the same point and serve as a decoupling resistor and bypass capacitor. In order to apply video modulation to this RF carrier, the supply voltage for Q8 and Q9 is taken from the emitter of modulator Q12. Q10, Q11, and Q12 are connected as a feedback amplifier with a nominal voltage gain of about 4. The video amplifier, modulator, clamp, keying, and audio systems are identical to those used in the 440-MHz version in Chapter 12.

Build Your Own Low-Power Transmitters: Projects for the Electronics Experimenter

The entire transmitter draws around 5–7 watts DC power at 13.8 volts and typically outputs 2–3 watts peak power on sync tips. This means that around 5 watts of heat may be generated. Because this transmitter is physically small, some attention should be given to thermal considerations. The same measures specified for the 440-MHz transmitter can be used on these units; however, the RF wiring to the antenna is more critical at these higher frequencies. In fact, the 1300-MHz output from the higher-frequency unit is actually in the microwave range, and suitable connections using proper connectors and lead dress are important. It is not surprising to find out that an initially disappointing 0.5-watt output from a “mediocre” unit can be increased to the specified 1 watt just by keeping RF connections from the PC board to the output RF very short. A fraction of an inch of wire that you may think is a dead short can look like a fair amount of impedance at 1300 MHz.

Construction Procedures

Before beginning construction, note that the construction procedure is almost identical to the 440-MHz version in Chapter 12. The only differences are the use of an extra transistor and a few more passive components; however, the higher frequencies used make construction precautions given for the 440-MHz transmitter even more applicable here. The near-microwave frequencies in the output circuit demand very close to zero lead lengths, and correct RF cable connections are even more important. Connections even 1/8 inch too long can cost you output power and performance. (See Figures 13-2 through 13-5 for parts layout and Figures 13-6 and 13-7 for PC board details.)

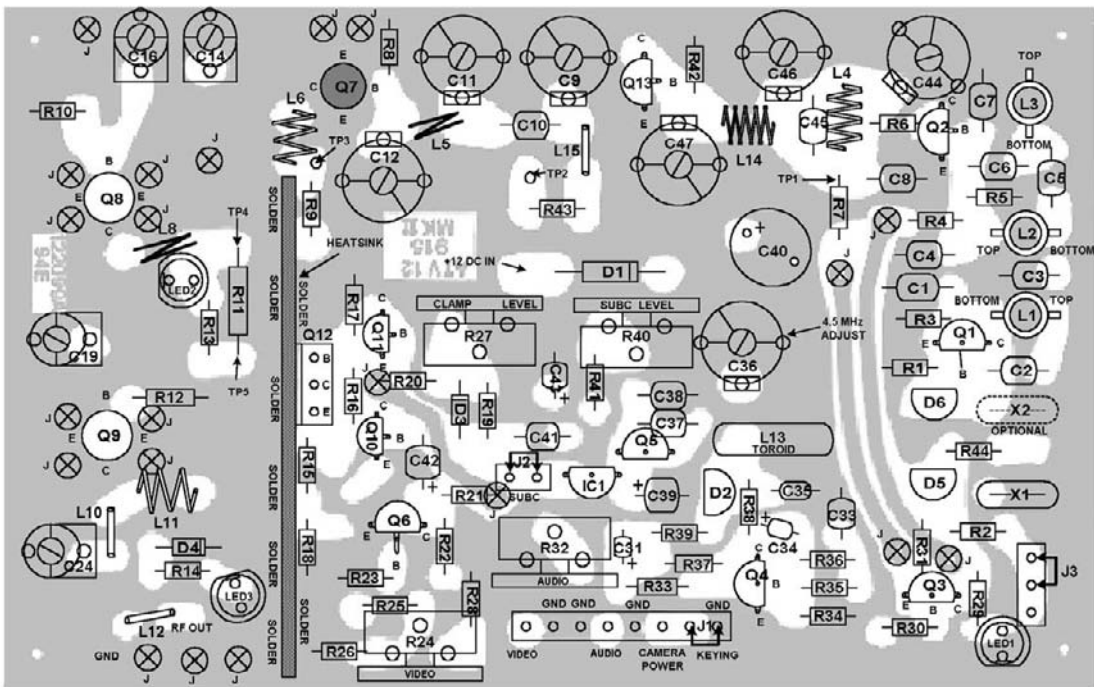

Figure 13-2
Parts Layout of the Component Side of the ATV12-900 MKII

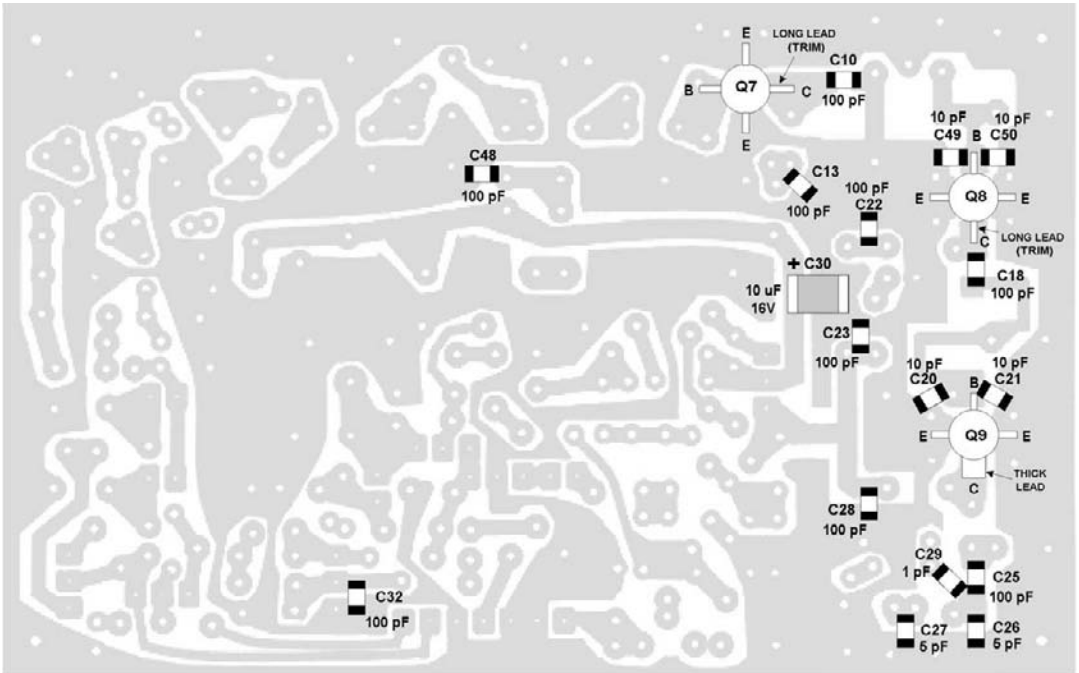

Figure 13-3
Parts Layout of the Solder Side of the ATV12-900 MKII

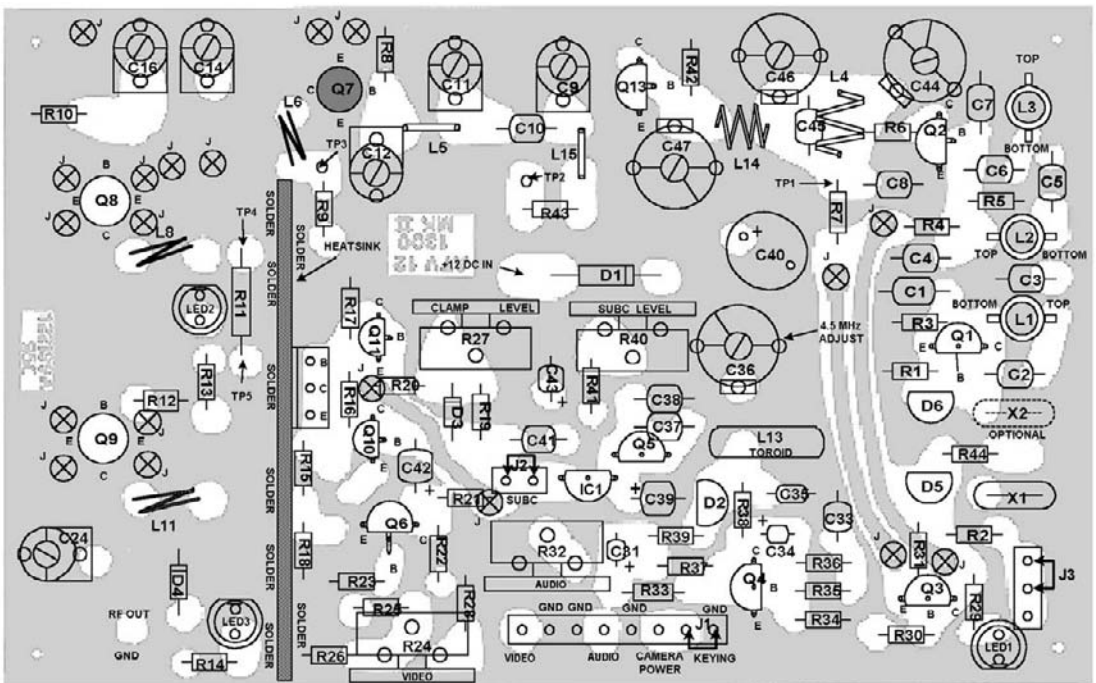

Figure 13-4
Parts Layout of the Component Side of the ATV12-1300 MKII

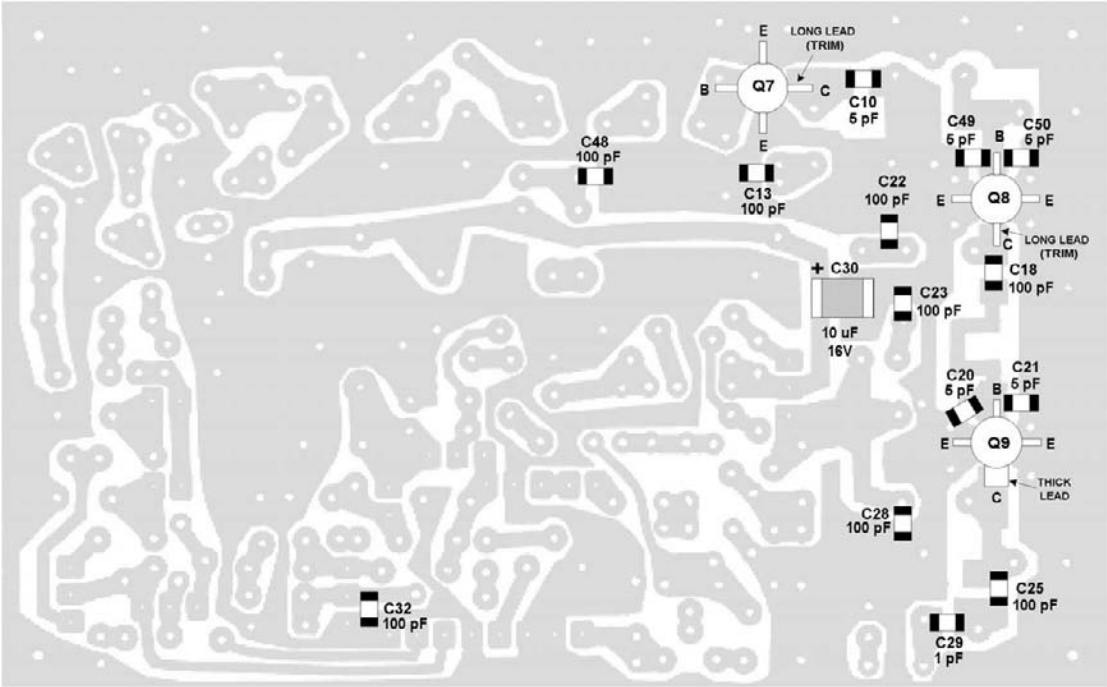

Figure 13-5
Parts Layout of the Solder Side of the ATV12-1300 MKII

Figure 13-6
Solder Side of the
PC Board for the
ATV12-900 MKII



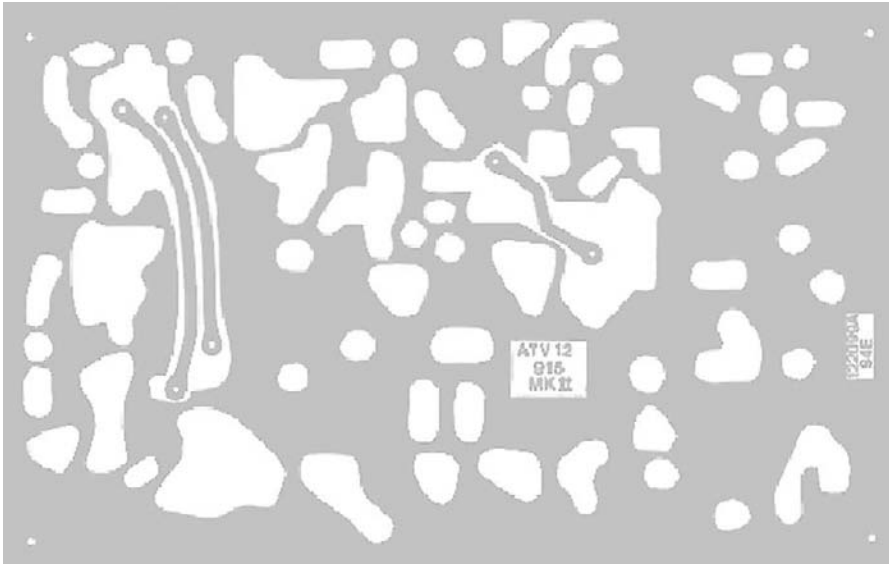

Figure 13-7
Component Side
of the PC Board
for the ATV12-900
MKII



Figure 13-8
Solder Side of the
PC Board for the
ATV12-1300 MKII

Tuneup Procedure

The following equipment is required:

- VOM analog preferable 20K/volt
- Power supply 13.2 volts regulated to 1.0 ampere or better
- Ammeter 0–1 ampere (not required if power supply has metering)

Figure 13-9
Component Side
of the PC Board
for the ATV12-
1300 MKII

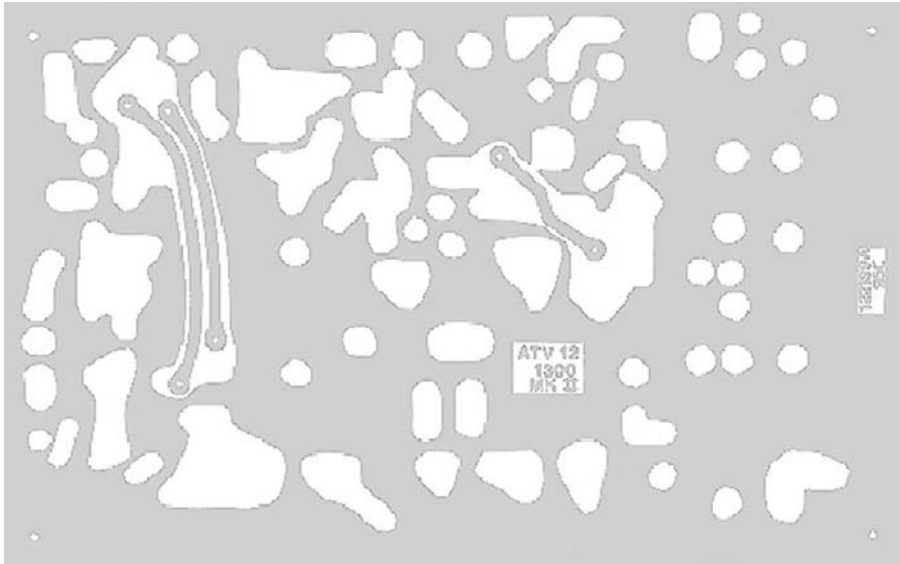

- Test leads, RF cables, and fittings as needed
- Video and audio source (VCR, camera, camcorder, etc.)

The following equipment is desirable but not necessary:

- 50-ohm dummy load, preferably with meter, good to 500 MHz
- Frequency counter good to 1500 MHz
- Variable power supply 13.2 volts regulated to 0–15 volts at 1 ampere
- Receiving setup for ATV reception that covers 900 or 1300 MHz as required

Refer to the schematic and PC layout as required. Preset all trimmer capacitors and potentiometers (for 900 MHz) as follows:

C9: 50%	C16: 40%	C46: 60%	R32: 25%
C11: 50%	C19: 20%	C47: 40%	R40: 25%
C12: 20%	C24: 30%	R24: 70%	
C14: 40%	C44: 30%	R27: 70%	

For the 1300-MHz version, use these presets:

C9: 10%	C16: 30%	C44: 30%	R27: 70%
C11: 50%	C19: NA	C46: 60%	R32: 25%
C12: 20%	C24: 15%	C47: 40%	R40: 25%
C14: 20%	C36: 50%	R24: 70%	

For both versions, set slugs in L1, L2, and L3 halfway into the coil. Note that slugs project out of the top of the coil, not out of the bottom. If you can set slugs to project out of the bottom of the coils, then the coils are mounted too high off the PC board. Correct this problem before proceeding further.

The percentages are the amount by which the plates of the trimmer mechanically overlap with respect to full setting, or percent rotation in the case of potentiometers.

L1, L2, & L3

Wind coils using #22 enamelled wire. Use 8-32 machine screw as a mandrel, winding wire in screw threads to form coil. Form leads, as shown, remove enamel and tin before installation. Install in PC board using screw as holding tool. Remove screw and insert slugs.

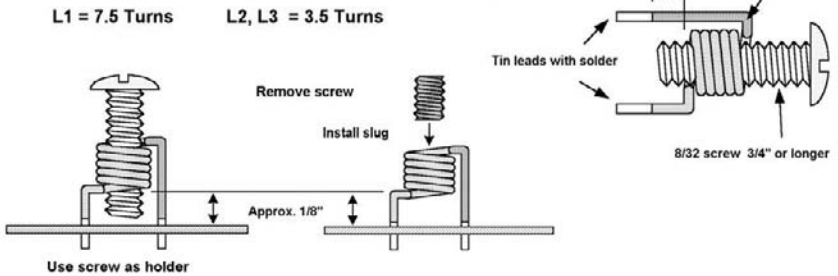

Figure 13-10
Coil Winding Data
for the ATV12-900
MKII

L4, L5, L6, L8, L11, & L15

Wind coils using #22 bare. Use 8-32 machine screw as a mandrel, winding wire in screw threads.

Form leads, as shown. Install in PC board using screw as holding tool. Remove screw. No slugs are used.

Install in PC board as shown.

- L4 = 4.0 Turns
- L5 = 5.0 Turns
- L6, L11 = 3.0 Turns
- L8, L15 = 1.5 Turns

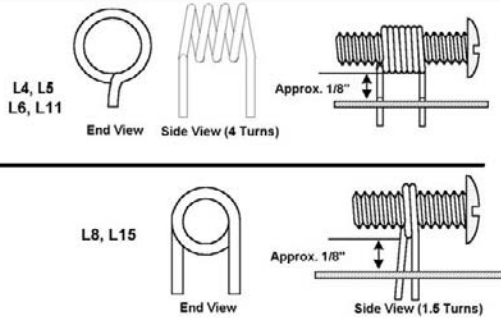

L10, L12, L14

L10, L12, L14 = 0.5 Turn
Semicircle
Use #22 Bare wire
Form inductor as shown

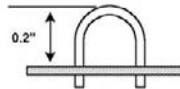

L13 Toroid

L13 = 14 Turns #22 enamelled
on toroidal core

14 turns #22 gauge enamelled wire on 0.375" dia. Ferroxcube toroid 3E2A material. Strip insulation, tin, and mount in PC board.

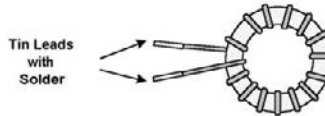

- A) Each pass through hole counts as 1 turn.
- B) Remove enamel and tin leads as shown.
- C) Install in PC board tight to surface, per layout.

They most likely are not optimum but close enough to ensure that you start in the correct "ballpark," assuming you have made the coils correctly as specified. Perform the following steps in order, and do not proceed to the next step unless you get specified results. Where readings may differ between the two versions, voltages for the 1300-MHz unit are shown in parentheses after those for 900 MHz.

1. Connect the 0–1 ampere meter in series with the positive supply lead if your DC supply has no built in ammeter that can read currents between 0.1–1 ampere. Connect the transmitter output to the dummy load and RF indicator. *Do not use an antenna.* LED3 will give a good indication of RF output. At proper output, it will glow brightly. Keep the 100-ohm resistor leads less than 1/4 inch long to minimize stray inductance and circuit detuning.

Figure 13-11
Coil Winding Data
for the ATV12-
1300 MKII

L1, L2, & L3

Wind coils using #22 enamelled wire. Use 8-32 machine screw as a mandrel, winding wire in screw threads to form coil. Form leads, as shown, remove enamel and tin before installation. Install in PC board using screw as holding tool. Remove screw and insert slugs.

L1 = 7.5 Turns L2, L3 = 3.5 Turns

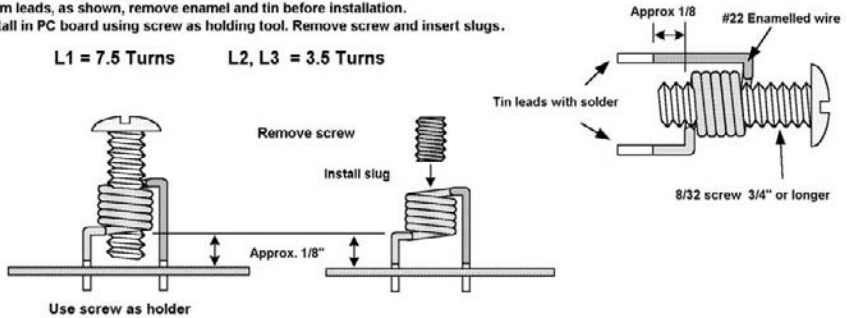

L4, L5, L6, L8, & L11

Wind coils using #22 bare. Use 8-32 machine screw as a mandrel, winding wire in screw threads.

Form leads, as shown. Install in PC board using screw as holding tool. Remove screw. No slugs are used.

Install in PC board as shown.

L4 = 2.0 Turns
L5 = 3.0 Turns
L6, L8, L11 = 1.5 Turns

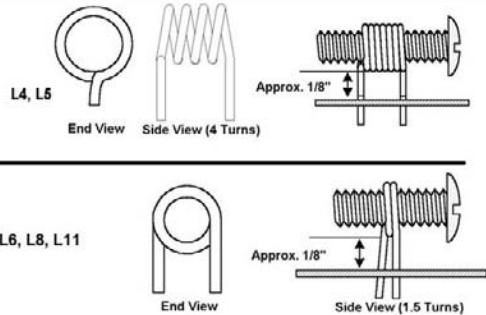

L14, L15

L14, L15 = 0.5 Turn Semicircle

Use #22 Bare wire
Form inductor as shown

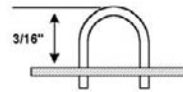

L13 Toroid

14 turns #22 gauge enamelled wire on 0.375" dia. Ferroxcube toroid 3E2A material. Strip insulation, tin, and mount in PC board.

L13 = 14 Turns #22 enamelled
on toroidal core



- A) Each pass through hole counts as 1 turn.
- B) Remove enamel and tin leads as shown.
- C) Install in PC board tight to surface, per layout.

2. Connect a DC supply of 13.2 volts to the transmitter. Make sure the keying line from R30 is grounded. You may use a jumper on pins of the eight-lead header to do this. The LED1 green LED should light. Remove the jumper or momentarily disconnect the keying line from ground and confirm that LED1 goes out. Make sure that jumper J3 is on the three-pin header selecting the higher-frequency crystal. Make sure that jumper J2 is installed to activate the audio section. Note current consumption, which should be 30–70 mA. Connect the positive lead of the VOM to the emitter of Q12 (TP4) and the negative lead to the ground. Verify that R27 can vary this voltage from less than 2 to more than 11 volts. Observe that the yellow LED2 lights vary in brightness with the setting of R2Adjust R27 for maximum voltage at the emitter of Q1This is also maximum LED2 brightness.

3. Connect the VOM across R7 (TP1) and the positive supply TP4. Peak L1, L2, and L3 for maximum DC voltage reading, about 2–3 volts (1.5–2.2) typically for both versions.
4. Connect the VOM across R9 (TP2) and the positive supply TP4. Peak C44 and C46 for maximum DC volts. Leave C47 alone for now. Approximately 1.5–2.2 volts is typical for both versions. If output is low, leave the VOM connected and try repeaking L1, L2, and L3. If the VOM is still below 1.5 volts, go back and check for proper component placement.
5. Connect the VOM across R11 (TP3) and modulator output TP5. Peak C9 and C11 for maximum DC volts. Peak C47, C44, and C46. Leave C12 at preset for now. Approximately 1–2 volts (1–1.5) is typical. If output is less than 1 volt, check the dimensions of L6 and L1. If output is still low, leave the VOM connected and repeak all previous adjustments you have made so far to maximize the meter reading. If the VOM is still low after peaking all adjustments, go back and check for proper component placement. LED3 may start to glow red during this step, which is a good sign.
6. Watch the red LED3 and slowly adjust C19 for any detectable glow or any increase in power supply current (900-MHz version only). When any detectable glow is noticed, peak C19 and C29 for maximum glow (only C29 on 1300-MHz version), then readjust C14 and C16 as needed. Adjust C12 and repeak C14 and C16 for maximum glow. Watch the ammeter in the supply lead. You can also use the voltage between TP4 and TP5 as a tuneup aid, going for maximum, which is about 1 volt for both versions, after tuneup. As LED3 brightens, power supply current increases to around 400–600 mA. The dummy load should indicate RF power if it has a built-in meter. This response indicates the presence of RF output and is normal.
7. Next, adjust C19 (900 MHz only) and C29 again for maximum RF output. At least 1 watt (900 MHz), or if 1300 MHz, 0.7 watt should be obtainable, and typically 1.5 watts at 900 MHz or 1 watt at 1300 MHz will be obtained after optimizing tuneup adjustments (with a 13.8-volt DC supply). Repeat tuneup steps as required for maximum RF power output. Q8, Q9, and Q12 normally run quite warm after a few minutes. Some slump in RF power output may result (20–30 percent) because of the small size of the RF PA transistor, with attendant limits on heatsinking. You can install fins on the PC board if you wish, but in practice the RF PA will be operating at reduced power under conditions of modulation, and heating will be somewhat less.
8. Reduce the power supply voltage, and note the voltage where RF output drops out. This should be typically less than 10 volts. If not, retune C44, C46, C47, C9, C11, C12, C14, C16, C19 (900 MHz only), and C29 as needed. Restore the 13.2-volt power supply and see if satisfactory RF output is obtained. Retune as required. Expect to experiment a little because adjustments may interact somewhat, which is normal. Your final trimmer settings should not be radically different from the presets if you have made the inductors correctly and the chip capacitors are properly installed.
9. When you are done with RF alignment, adjust clamp level control R27 for about 60 percent of full RF output. The yellow and red LEDs will dim slightly, which is fine. If you have one, connect a frequency counter to the emitter of Q12 (TP4). You should see a reading of around 4.5 MHz. Adjust C36 for a reading of 4.495–4.505 MHz. If you are too high or low at the limits of adjustment of C36, add or subtract a turn from L13 as required. If no

Build Your Own Low-Power Transmitters: Projects for the Electronics Experimenter

- counter is available, adjust C36 for best audio while monitoring the transmitted signal on a receiver. (Information for PAL operation is given on page 136.)
10. Place a drop of Duco cement or clear lacquer on L1, L2, L3, and toroid L13 after tuneup is complete. This step provides mechanical stability and anchors the slugs of L1, L2, and L3.
 11. Apply video and audio to the transmitter and adjust R24 and R27 for best picture. R24 will affect contrast, whereas C27 affects brightness and stability. Correct adjustment gives a good, stable picture with no blocked-up highlights or lowlights, and freedom from rolling, tearing, or other instabilities. Make sure the receiver is not overloaded and situated at least 10 feet from the transmitter. Audio gain is set with R3. If sound bars are noticed in the picture, adjust R40 to eliminate them. Audio buzz may be pronounced if video gain R24 or clamp R27 are set too high.

If continuous operation is contemplated, keep the supply voltage between 12.0–13.2 volts, unless additional heatsinking is provided for Q9 and Q12. Do not exceed 15 volts or you may damage the RF and modulator circuitry. For low-voltage applications (9.6-volt battery supply), it would be best to repeat all adjustments at this voltage after initial tuneup has been done. Battery voltage falloff is less well tolerated at this low-supply voltage because the design has been optimized for 11- to 15-volt supply voltages. A properly tuned transmitter might function typically down to about 8.5 volts, but there is no guarantee of this, and at best RF power output will be around 0.5 watt. As with the 440-MHz model in Chapter 12, the transmitter is safe from any damage at this supply voltage. We cannot guarantee operation at this low voltage, and the 900- and 1300-MHz models are not as tolerant of reduced voltages because of lower-stage gains at the higher frequencies, but it is possible, and the information herein is presented for those who wish to experiment.

Parts List

Resistors 1/8W 5% (Unless Otherwise Specified)

R1, R15, R16, R17, R20, R23, R25, R31, R42	1.0 K ohm
R43	33 ohm
R3, R18, R26	330 ohm
R4, R7, R10 (see Note), R2, R5, R13	100 ohm
R29, R30, R44	2.2 K ohm
R6, R11	10 ohm
R8	220 ohm
R9, R12	22 ohm
R14, R21	470 ohm
R19	22K ohm
R22, R33, R37	4.7 K ohm
R24, R27, R40	PT10 pot, 1.0 K ohm
R28	82 ohm
R32	PT10 pot, 100 K ohm

1-Watt TV Transmitters for 902-928 MHz and 1240-1300 MHz

Resistors 1/8W 5% (Unless Otherwise Specified) (cont.)

R34, R36	33 Kohm
R35, R39	100 K ohm
R38, R41	10 K ohm

Note: R7 is 33 ohms, and R10 is 68 ohms for 1300-MHz version

Semiconductors

D1	1N4007
D2	MV2112
D3, D4	HP 5082-2835
LED1	LED, green
LED2	LED, yellow
LED3	LED, red
Q1	2N3563
Q2, Q13	MPS3866
Q3, Q11	2N4355
Q4	2N3565
Q5	MPF102
Q6, Q10	2N3904
Q7, Q8	MRF559 (MRF837 preferred on 1300 MHz)
Q9	MRF557
Q12	MJE180
IC1	LM78L05

Capacitors (Note: Values in parentheses are for 1300 MHz)

C1, C7	56 pf NPO ceramic (C7 47 pf)
C2	39 pf NPO ceramic
C3	18 pf NPO ceramic
C4, C41	.01 disc 50V GMV
C5	2.2 pf NPO ceramic (C5 3.3 pf)
C6	33 pf NPO ceramic
C8	470 pf disc ceramic
C44, C46, C47	2-10 pf, 7.5 mm
C9, C11, C12	2-10 pf, 7.5 mm (C9, C10, C12 1-5 pf)
C14, C16, C19, C24	1-5 pf, 7.5 mm (C19 NA)
C10	2.2 pf NPO ceramic (C10 1.5 pf)
C15	Part of PC board
C29	1.0 pf NPO ceramic
C20, C21	10 pf chip 60 × 120 (5 pf)
C13, C17, C22, C23, C25, C32, C49	100 pf chip 60 × 120 (C17 5 pf)
C26, C27	4.7 pf NPO ceramic (not used on 1300)
C30	10 uf 16V chip tant.

Build Your Own Low-Power Transmitters: Projects for the Electronics Experimenter

Capacitors (Note: Values in parentheses are for 1300 MHz)	
C31, C34	0.47 or 1.0 mf 35V tant.
C33	.0022 uf mylar
C35	.001 uf mylar
C36	2-20 pf, 7.5 mm
C37	68 pf NPO ceramic
C38	120 pf NPO ceramic
C39, C42	10 uf 16V elec
C40	470 uf 16V elec
C43	100 uf 16V elec
C28	Not used

Coils and Chokes	
1 ea	Core, toroidal, 266T125-4C4
24"	#22 enamelled wire
24"	#22 tinned wire
3 ea	Cambion blue slug
1 ea	8-32 × 1" screw for coil-winding form

Miscellaneous	
1 ea	Crystal, third OT, as required (see text)
1 ea	PC board
1 ea	Heatsink and shield, (G-10 material)
1 ea	4-40 × 1/2 BHMS
1 ea	#4 Lockwasher
1 ea	#4 Nut
1 ea	TO-220 Mica insulator
1 ea	8 pin header 0.1" spacing
1 ea	3 pin header 0.1" spacing
1 ea	2 pin header 0.1" spacing
3 ea	shunts for header

A kit of parts consisting of complete documentation, a drilled and etched printed circuit board, all parts that mount on the board, and one crystal for 910.25 MHz or 1289.25 MHz (as applicable), as well as a complete hardware kit and a two-tone painted aluminum case for construction of these transmitters, are available from the following supplier:

North Country Radio
P.O. Box 53, Wykagyl Station
New Rochelle, NY 10804-0053
E-mail: support@northcountryradio.com
Website: www.northcountryradio.com

Please be sure to specify which version (900 or 1300 MHz) is desired. Check their website at www.northcountryradio.com for current prices.

14. Experimental 20 mW 915 MHz PLL FM TV Transmitter

For TV transmission, the use of frequency modulation as a way of modulating the video on the carrier has certain advantages. We discussed some of the advantages of FM for audio transmission in Chapter 2, and these apply to video as well. FM video requires large bandwidths. A rule of thumb is twice the deviation plus the highest modulating frequency. In order to keep bandwidth reasonable, this transmitter employs 3-MHz deviation. The use of such a relatively small deviation results in a modulation index (deviation divided by modulating frequency), also known as β (beta) of only around 1 at the highest video frequencies. Commercial satellite TV uses 10- to 12-MHz deviation and a receiver bandwidth of up to 30 MHz.

The FM improvement factor over a comparable AM system when the received FM signal is well above threshold is 3β squared, so a modulation index of 1 gives a signal-to-noise (s/n) improvement of 3 with a 3-MHz modulating signal and a 3-MHz deviation; however, most video components are lower in frequency, and at 1 MHz, still corresponding to finer detail, the improvement is nine times. Although very weak-signal performance of an AM system is still better than with an FM system, a 20 dB s/n ratio AM transmission, reasonably good for speech, is very poor for AM, and at this level, an FM signal will give a good picture. Satellite TV reception would be much poorer with AM signals, which is one reason why FM is used for satellite TV.

This chapter describes a simple phase locked loop (PLL) FM TV low-power transmitter for 915 MHz. The frequency synthesizer has a resolution of 0.25 MHz, giving 104 channels in the 902–928 MHz band. In practice, the transmitter should be operated between 907–923 MHz because sideband components at these limits could extend to the edges of the 902–928 MHz band. Power output is 1–2 milliwatts (mW), and with a 3-inch whip antenna, it easily covers an entire house. Reception of the signals requires a dedicated receiver, which consists of a tuner to convert the 900-MHz signals to a lower IF of around 70 MHz, and then an IF amplifier and a special wide-band FM video detector. An existing 900-MHz FM video receiver can be used, or you can build the IF and downconverter discussed elsewhere in this book. This process is not difficult because SAW filters are used and no alignment is needed except for one simple adjustment. A 900-MHz downconverter into an ordinary NTSC AM TV set will not be satisfactory, however. Although the signal could be detected, the picture quality would be poor.

Until a few years ago, the feasibility of building a low-cost 900-MHz PLL-synthesized transmitter as a home experimenter project would have been questionable. Now, if you don't mind a little work with today's surface-mount devices, it is perfectly feasible. Several UHF prescaler chips are available. The UPC1507 by NEC used in this project was tested by the authors and found to operate up to 4000 MHz. At this frequency, the output was 15.625 MHz when configured to divide by 256.

(This is done by presetting logic states at two of the device pins.) Although it is small and a bit tricky to work with, only a few connections are needed. With the aid of a 10-watt soldering iron, tweezers, and a jewelers' loupe, it is really not too bad to deal with. Although tiny, the pin layout is user friendly and allows easy layout. Approximately 10 chip components are also used in the UHF portion of the circuit. The prescaler is set to divide by 64, and this ratio is fixed. The prescaler output feeds a Motorola MC145151P2 PLL IC, which is operated at a reference frequency of 3.90625 kHz. This is internally derived inside the chip from an 8-MHz external crystal and an internal oscillator circuit, with the chips' internal divider programmed via external connections to divide by 2048. Very few parts are needed, and a single trimmer sets the oscillator exactly on frequency.

Because the reference frequency is 3.90625 kHz and the prescaler is configured to divide by 64, the resolution of the synthesizer is 250 kHz (64×3.90625 kHz). RF output at 915 MHz is taken directly from the 902–928 MHz voltage controlled oscillator (VCO), and no buffer is used. This is a compromise to avoid extra circuitry, which was found to work well because little power is needed. Video from a simple video amplifier and preemphasis network is applied directly to the VCO, directly producing FM. Audio is added by a simple audio amplifier and a 4.5-MHz VCO circuit. Although 5.8- or 6.8-MHz audio subcarriers are customarily used in FM video work, this level is a little too high for the relatively narrowband FM system discussed here, so the conventional 4.5-MHz subcarrier used with AM transmission is employed instead. It works well, and standard 4.5-MHz ceramic filters and traps can be used. Received picture and sound are excellent. Purists may criticize this non-standard approach, but it works well in practice. This allows a 10-MHz receiver bandwidth to be used with no problem because the subcarrier is generally 20 to 26 dB below peak video (corresponding to 5–10 percent total deviation) and fits in the IF passband at the receiver.

Referring to the schematic shown in Figure 14-1, most of the components used in this project are found in the frequency synthesizer. The rest are used in the video amplifier, preemphasis network, and audio subcarrier generator. Video input across gain control R1 is limited in amplitude by diodes D1 and D2 and associated components. Q1 is an emitter follower and drives a passive component preemphasis network R6–R10, C4, and L7. The preemphasis network has a standard CCITT recommended curve, and its function, reason for use, and behavior are analogous to the audio preemphasis network used in an FM audio transmitter. R7–R10 are each actually parallel combinations of two resistors to get the nonstandard resistor values needed for the network. This is done so that standard-value inductors and capacitors can be used, which are harder to get than resistors. R11 and R12 terminate the preemphasis network and feed video to C13, which couples video to the VCO through choke L3.

Audio input is fed to audio gain control R16 and an audio amplifier and 4.5-MHz VCO to produce an FM subcarrier. Because this circuit is exactly the same as the one used in the 2-watt ATV transmitter in Chapter 12, a detailed description is not given here. The reader should refer to Chapter 12 for a detailed circuit description of this audio portion of the 900-MHz FM video transmitter. R13 controls the level of the 4.5-MHz audio subcarrier injection, which should be about 5–10 percent of the peak video level.

Q4, a BFR90, and associated components make up a VCO in the 900-MHz range. R30, R31, R32, and R33 bias Q4, and the oscillator circuit is a Colpitts type, with C27 and the stray emitter to ground capacitance making up the feedback network. Varactor diodes D4, C15, and L2 form the tank circuit, which determines oscillator frequency. L3 is a small RF choke, and C25 couples RF to output pad network R34,

Figure 14-1
Schematic of a
902-928 MHz PLL
FM TV Transmitter

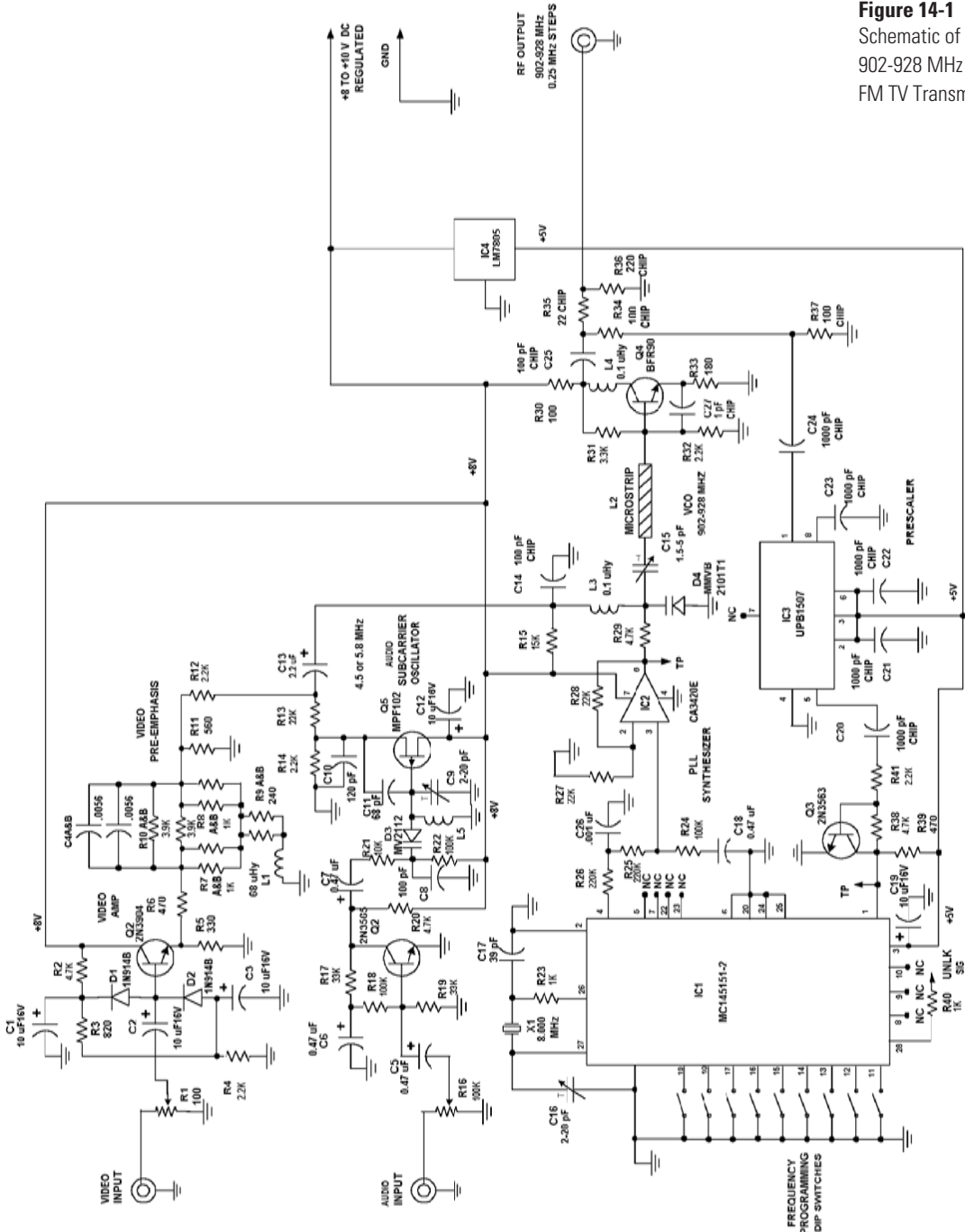

R35, and R36. The oscillator gets its collector return via this pad and the load. A sample of the RF output is fed to prescaler IC IC3 via R34, R37, and C24. The output of IC3 is 1/64th the input frequency. This is fed to driver amplifier Q3 and associated components, to pin 1, the MC145151-2 PLL-synthesizer chip input pin. It is further divided in frequency internally in the PLL chip by a variable frequency divider circuit. This circuit has its divide ratio set via DIP switch S1 connected to

nine pins of the MC145151-2. It is then compared with a reference frequency derived from another internal oscillator. C16, 8.000 MHz crystal X1, C17, and R29 are part of this oscillator circuit. This frequency is divided internally by 2084 to produce the 3.90625-kHz reference frequency.

When the variable divider output frequency agrees with the reference frequency and is in phase with it, a steady-state DC voltage component, together with very narrow pulses at the reference frequency, appears at pin 4 of IC3. This is fed to a lead lag network C18, and R24, R25, and R26. This network controls the synthesizer loop characteristics, and component values must be chosen carefully to obtain the desired synthesizer performance. Also, note that the variable divider must divide by a number in the range of 3608–3712. This is a range of 104 discrete states, and a DIP switch with 10 positions was used, with only eight sections actually needed. A divide ratio of 3660 is needed for a 915-MHz (band center and also desired transmit frequency) output. The divide ratio is equal to the binary number programmed into the chip pins. This can be a maximum of 16383. Fourteen pins are reserved for this function designated N0 (least significant) to N13 (most significant). They have internal pullup resistors so that for a logical one to be put on any pin, it can be left open.

Grounding a pin places a logic zero on it. Therefore, it must be remembered that in this circuit, because a series of switches returned to ground (DIP switch used for this), if any DIP switch position is ON, a logic zero is presented to the pin it is connected to. The more significant pins N9, N10, and N11 are floating, and N12 and N13 are grounded, allowing a maximum of 3711 and a minimum of 3584. This gives a range of 896.00–927.75 MHz. Note that 928.00 MHz cannot be reached unless we use another DIP switch position, which would produce higher frequencies outside the desired range. The sacrifice of 928.00 MHz is no loss because we should confine transmissions to a range such that no closer than 6 MHz to a band edge is used. This limits the frequency range to 908–922 MHz to confine all emissions to the 902–928 MHz band. The DC output from the phase detector and lead-lag network is used to drive DC amplifier IC2, whose output controls the VCO frequency. This synthesizer operates exactly like the one discussed in the AM and FM low-power transmitters of Chapters 5, 6, 8, and 9, so again we discuss only the salient features of this particular circuit.

Loop filter R26, R25, R24, and C18 must be chosen to allow video modulation of the synthesizer. Video components cover about 30 Hz to 4 MHz in frequency, otherwise the principle is exactly the same as for FM of the VCO by audio signals. Note that there is no clamping of the video because the DC component of the video signal would not be accepted by the synthesizer. The synthesizer would simply treat it as an error voltage and correct the VCO frequency to eliminate the offset in frequency that would result if we would or could pass the DC component. Any synthesizer has a lower frequency limit at which it can be used to produce direct FM signal output. Remember that we are trying to produce a pure, clean, steady frequency with a PLL, and therefore frequency modulating the VCO in a PLL is kind of an oxymoron, in the sense of trying to get a stable, varying frequency. A low-frequency modulation limit exists, and it never can get to zero frequency (DC). Therefore, video clamping must be done at the receiver after video detection to restore DC relationships. The deviation in a video system must not exceed the system bandwidth; otherwise, severe video distortion, “sparklies,” and loss of sync will occur. Also, unlike audio, the video polarity matters. Reversing it results in negative video at the receiver. Even if the monitor accepted the incorrect polarity sync pulses, the picture would appear as a negative, tones reversed exactly like a photonegative.

The VCO output can be used directly or fed to an auxiliary buffer and RF amplifier. We did not pursue this option because the RF output from the VCO was adequate for a good picture at 100 feet from the transmitter. A receiver with a special IF strip was used. This receiver, consisting of a 70-MHz IF strip and downconverter, is discussed in Chapter 15. Several ICs that are designed for cell phones and wireless devices are available, and outputs of around 0.5–1 watt can be obtained from these. They use surface-mount technology, and these chips would be applicable to an RF power amplifier, or if preferred, a discrete component amplifier can be built up from available transistors.

The entire transmitter is built on a small board. We used a PC layout, as shown in Figures 14-2, 14-3, and 14-4, but “ugly bug” or vectorboard construction can also be used, except for the UHF portion, where an etched circuit layout is best because of short leads, close connections, and very small surface-mount component sizes. A detailed layout is shown in Figure 14-5 for the UHF portion, which should be duplicated as closely as possible. This section uses mostly chip components.

A kit of parts to build the transmitter, consisting of complete documentation, a drilled and etched printed circuit board and all parts that mount on the board, is available from the following supplier:

North Country Radio
P.O. Box 53, Wykagyl Station
New Rochelle, NY 10804-0053
E-mail: support@northcountryradio.com
Website: www.northcountryradio.com

Check their website for current price and an order form. A suitable two-tone aluminum case, a hardware kit, and a tuned “rubber ducky” antenna are also available from North Country Radio.

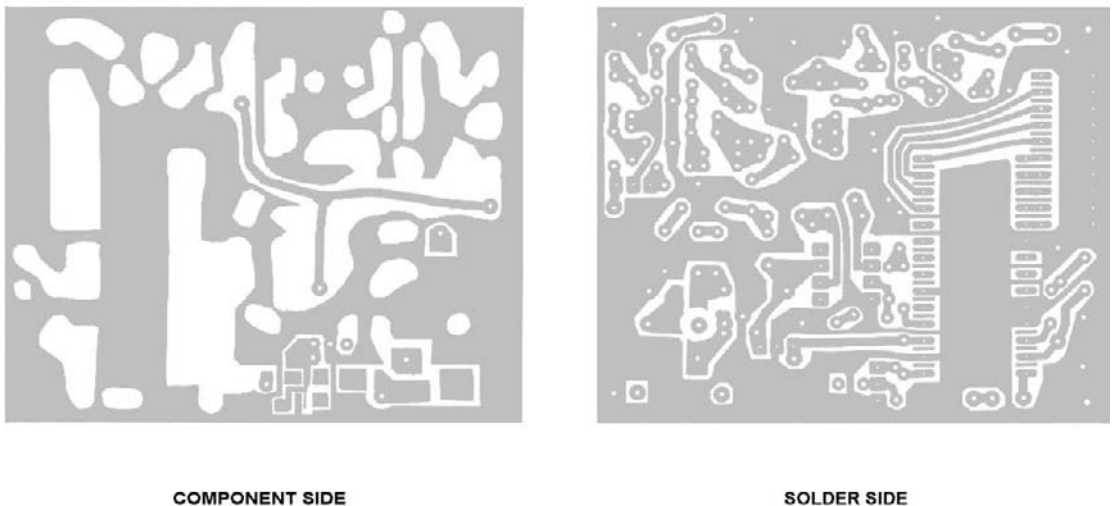

Figure 14-2
PCB Patterns for the Solder and Component Sides of the PLL FM TV Transmitter

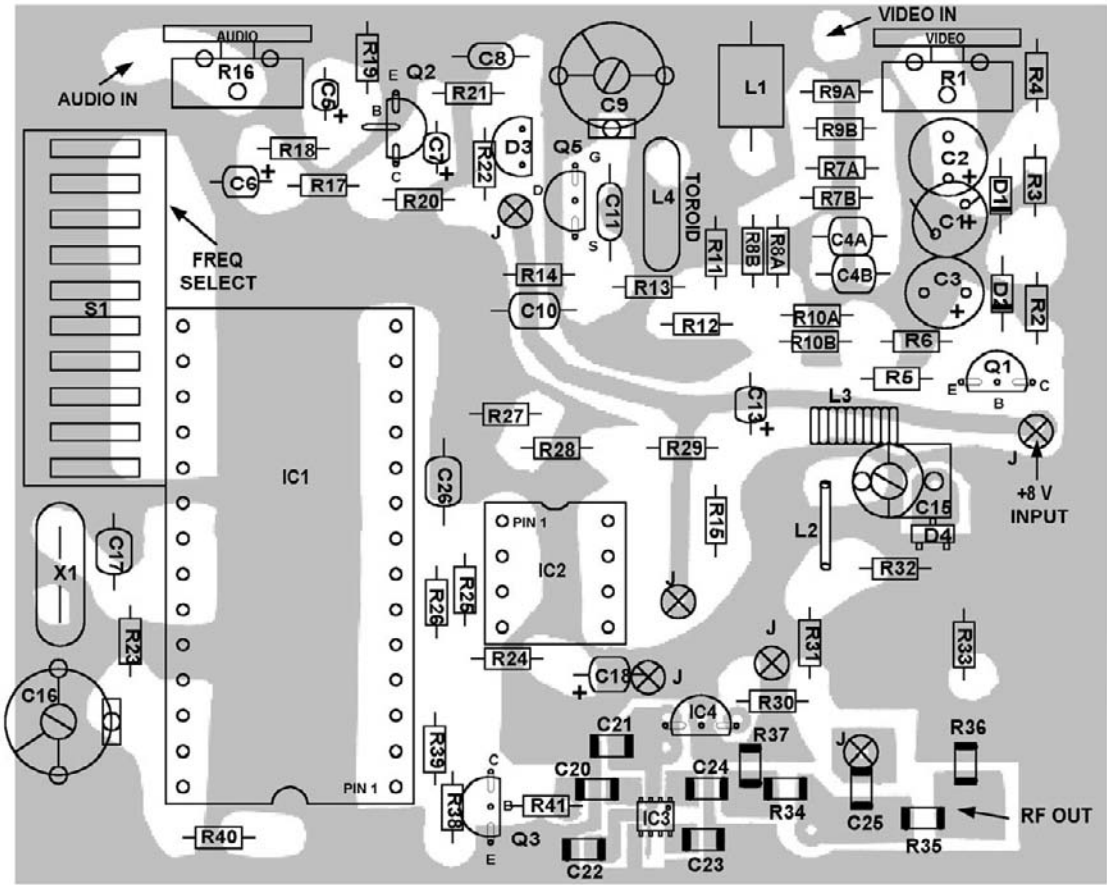

Figure 14-3
Parts Layout for the 902-928 MHz PLL FM TV Transmitter Component Side

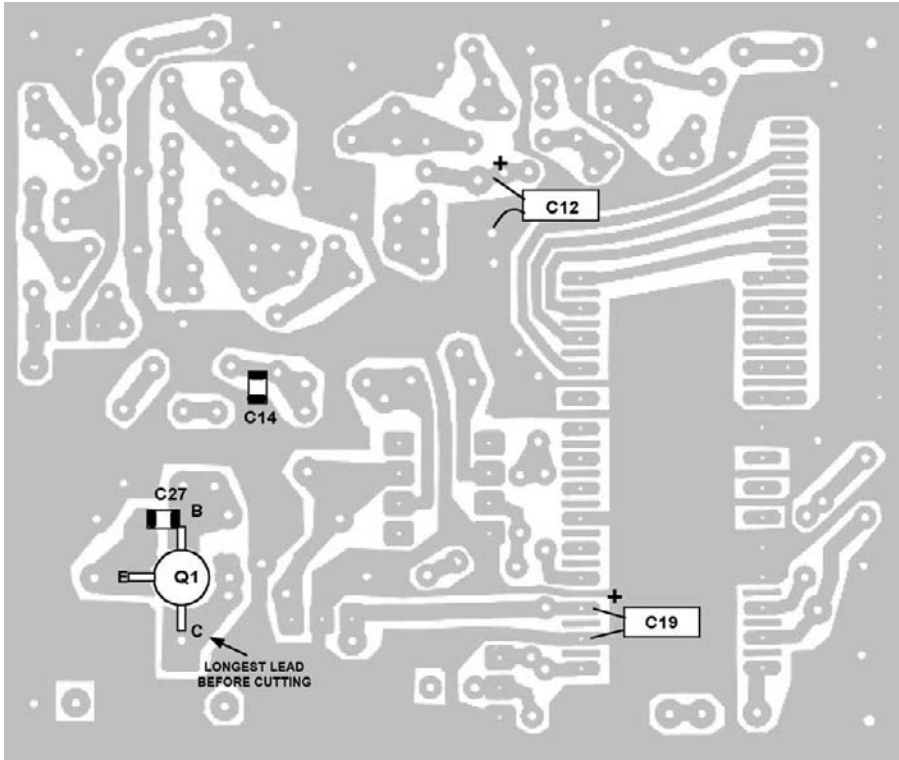

Figure 14-4
Solder Side Parts
Placement for the
902-928 MHz PLL
FM TV Transmitter

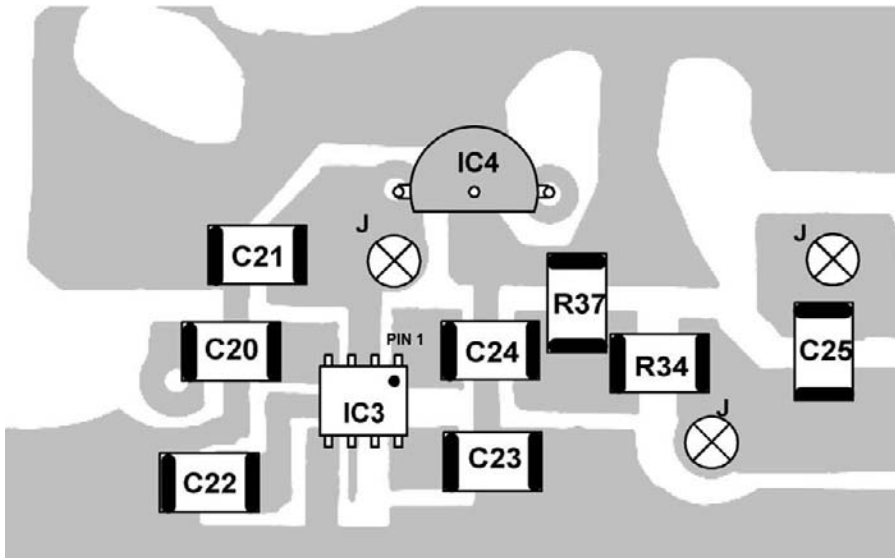

Figure 14-5
Detailed Layout of
the UHF Portion of
the 902-928 MHz
PLL FM TV
Transmitter

This Page Intentionally Left Blank

15. Receiving Converters and IF Systems for Low-Power ATV Transmitters

The use of small low-power transmitters requires some sort of a receiving setup. Although these transmitters can be operated on standard TV channels, this activity is illegal under current FCC rules. Legal alternatives are the 902–928 MHz band, which is used for both amateur radio and Part 15 devices, and the 420–450 MHz (70 cm) and 1240–1300 MHz (23 cm) bands; however, although the 420–450 MHz band can be tuned by cable-ready TV sets as cable channels 57 to 60, the 900- and 1300-MHz bands are outside the tuning range of TV sets and therefore some sort of converter is necessary. In addition, the use of FM for video requires a special IF and detector system. This chapter discusses downconverters and IF systems for these purposes.

The following paragraphs describe basic RF downconverters designed to convert television or other wideband signals in the 420–440 MHz (70-cm ham TV), 902–928, and 1240–1300 MHz ranges to a 61.25- or 67.25-MHz IF output frequency (Channel 3 or 4) to enable reception of these signals on a standard VHF TV receiver or monitor. They are sensitive, 1–1.5 dB noise figure (NF), stable, simple, and low in cost, about \$40–50 if all new parts are purchased and a homemade PC board is used. Parts kits to build these downconverters are available for those preferring to obtain all parts and a finished PC board.

Some cable-ready TV sets cover frequencies in the 420–440 MHz range, but most newer sets have frequency-synthesized tuners and are not capable of covering those frequencies between the 6-MHz channels used for CATV. Also, a preamp is generally needed with these sets for best weak-signal reception, and you still have an out-board device anyway. Therefore, a tunable downconverter still may be the best way to go.

The three downconverters are practically identical in circuitry, differing only in the tuned circuits (see Figures 15-1, 15-2, and 15-3). The 440-MHz downconverter uses small airwound coils consisting of a few turns of wire. In the 900- and 1300-MHz units, the inductors are printed on the PC board as stripline elements. Although it is possible to do this at 440 MHz, the PC board would have to be enlarged because stripline elements would be too large to fit comfortably. The IF and tuning circuitry are identical, as are mechanical size and interfaces. In fact, with the proper tuning components, this design could be used anywhere between about 400–1400 MHz. We did not test the circuit above 1400 MHz, but it still performed well there. Below 400 MHz, no amateur TV operation is allowed, so no tests were run below this frequency, although it should still work well.

The circuit uses five transistors and one IC voltage regulator. It consists of a low-noise RF amp feeding a mixer transistor, a tunable LO, and a feedback pair IF preamplifier stage. The RF amplifier is a low-noise, dual-gate MESFET that is followed by a mixer stage using a UHF bipolar transistor. Three tuned circuits are used

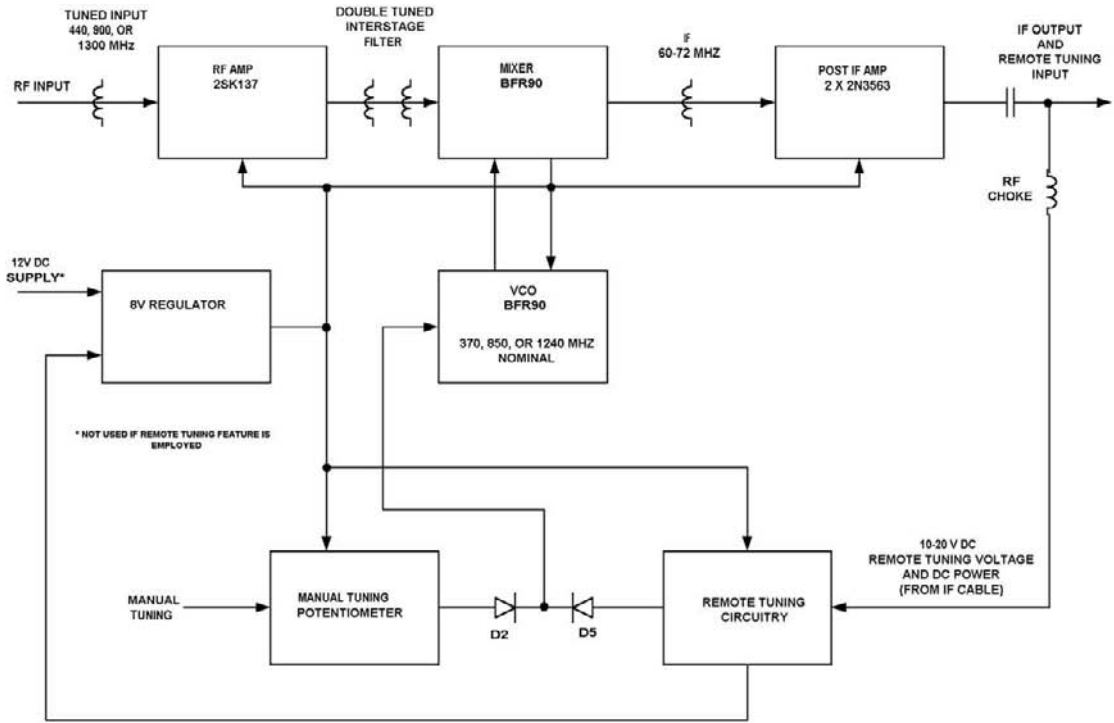

Figure 15-1
Block Diagram of 440, 900 and 1300 MHz Downconverters

in the RF amplifier. These are of conventional wound coil construction at 440 MHz because striplines are somewhat too large at 440 MHz to fit on the PC board used, measuring 2.5 by 4 inches. At 900 and 1300 MHz, striplines are used and no discrete wound coils are needed. The onboard local oscillator (LO) is voltage tuned and is tuned by either an onboard potentiometer or via the coax-fed DC tuning and supply voltage. All necessary circuitry for remote tuning is on board for coax DC and IF feed. This enables the downconverter to be mast mounted to avoid feedline losses that are generally associated with this frequency range. No separate DC feed is necessary because the coax (RG59/U or RG6/U is recommended) carries DC power, tuning voltage, and the IF signal. A DC block can be used at the receiver to separate the DC voltage supply and the IF output signal. This allows a cable run of several hundred feet if needed. Input impedance is 50 ohm, and any suitable 70-cm antenna can be used.

For conventional operation, the onboard tuning potentiometer may be used. The LO is voltage-tuned and is fed from a voltage regulator IC. The complete downconverter PC board is small at 2.5 by 4 by 1 inch. The power supply requirements are 11–20 volts DC at approximately 30 mA, or a variable supply from 11–20 volts for combined DC and IF feed on a single coaxial cable for remote tuning. Overall gain is 30–43 dB nominal (can be changed if needed) depending on frequency, with more than 20 MHz RF bandwidth and tuning range at 420–440 MHz operation. Tuning ranges are wider at 900 and 1300 MHz as needed to cover the bands. Please note that these downconverters are not intended for reception of narrowband FM or single

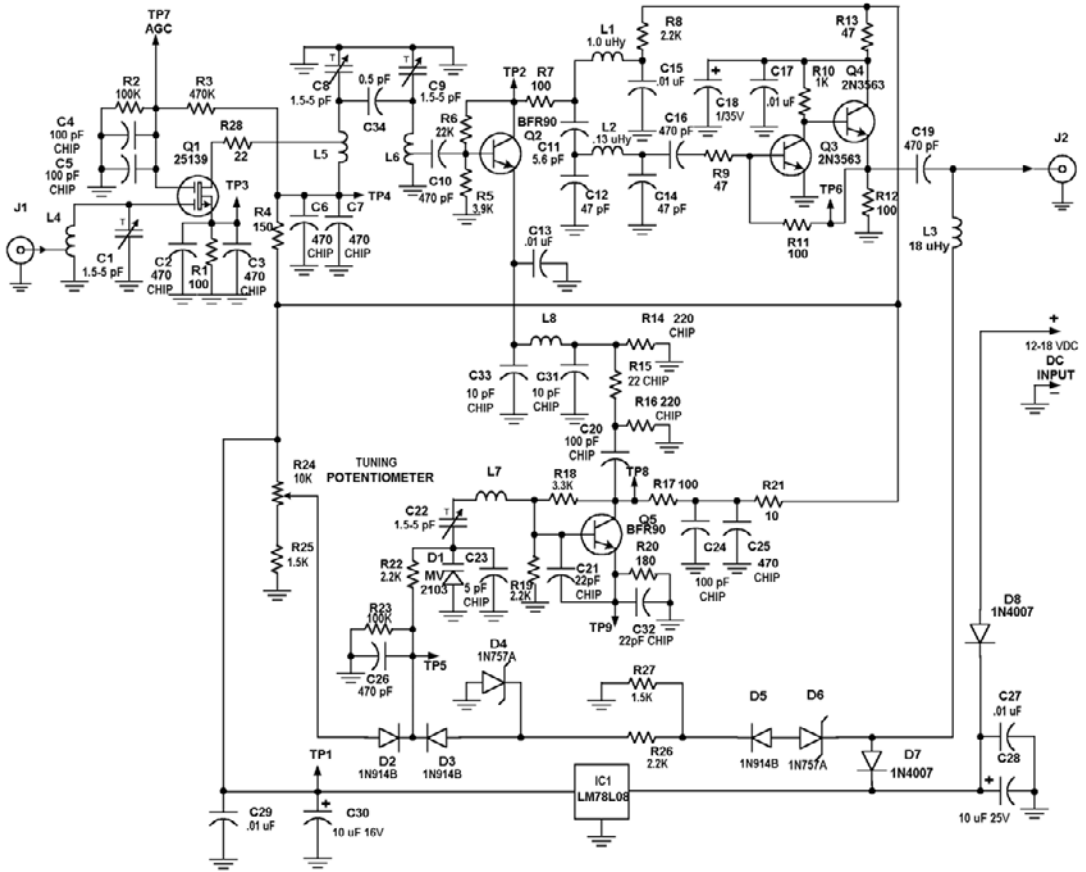

Figure 15-2
Schematic of the ATVC 439 Downconverter

sideband (SSB) signals because the converter uses a tunable LO covering 20 MHz or more (60 MHz at 1240–1300 MHz) with 270 degrees of shaft rotation. Also, the short-term stability of the local oscillator, although adequate for wideband reception, is not good enough for narrowband signals. They are primarily intended for wideband modes such as television. By the way, if you have no 440-MHz FM equipment but are curious about local 440-MHz FM activity, FM audio reception using a conventional FM broadcast receiver tuned to 90 MHz as an IF and audio is possible. You will hear audio, and it will be somewhat low in volume, but you can monitor 440-MHz FM repeaters to see if you might want to purchase 440-MHz FM gear or not.

You could also use the 900-MHz version in this manner to listen for studio-transmitter links (STL) around 940–960 MHz that are used by FM radio stations to send program audio to the FM transmitter, which may be located on a mountaintop. Directional antennas are used, however, and you would have to lie in the path or pick up a sidelobe from the transmitting antenna. All you will hear is the same audio program that the station is transmitting, less any audio distortion the transmitter might produce; however, this is technically illegal under current privacy regulations. So if you do so, do not do it for any commercial use whatsoever. Scientific curiosity in this

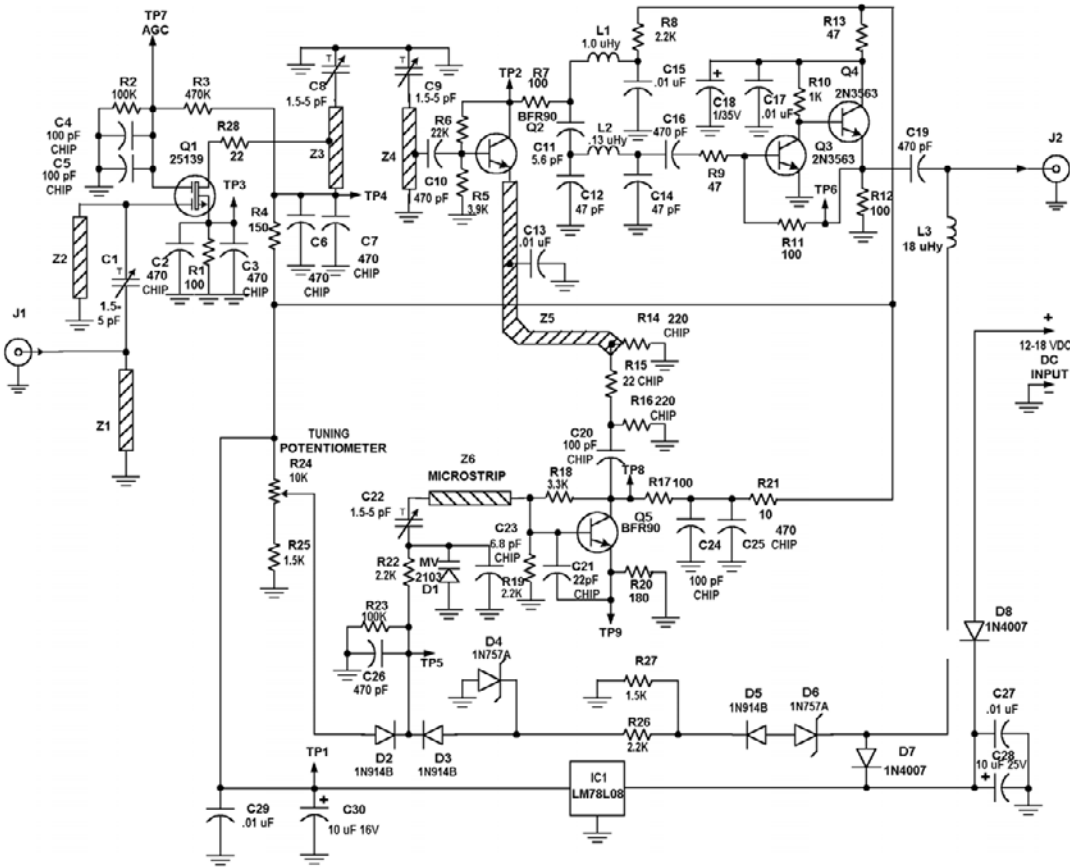

Figure 15-3
Schematic of ATVC 900 and ATVC 1300 Downconverters

instance harms no one, and these laws are probably not practically enforceable. Who is going to run a sting operation to “bust” someone for listening to STL signals? The authors know of no one who has been prosecuted for this action, but the law is the law. The 1300-MHz downconverter could be similarly used for wideband FM work on 23 cm, but at present no ham activity uses this mode on the band. The downconverter can be aligned simply by peaking for maximum received signal, with no tricky alignment procedures or specialized RF test gear necessary for good results and performance. The IF output frequency can be changed to anywhere between 40 and 100 MHz by changing one component and shifting the LO frequency.

Referring to the schematics of these downconverters, you will see that they are almost identical; therefore, the 440-MHz unit is discussed and comments made where applicable to any exceptions taken in the higher-frequency units. Input signal from the antenna jack J1 is fed to tuned circuit L4 and C1. (A matching inductor Z1 and tuning inductor Z2 are used at 900 and 1300 MHz instead.) C1 is a trimmer capacitor and is adjusted for best reception of a weak signal. The signal is applied to the gate of Q1, a low-noise MESFET with a noise figure of around 1 dB. Unavoidable circuit losses will raise the actual noise figure to typically 1.4–2.0 dB, which is

fairly good for the intended application. The source of Q1 is biased via R1, and G2 is biased by R2 and R3. Note that two chip capacitors bypass both source and G2 (C2 through C5), so the necessary very low inductance bypassing is obtained. Conventional 100 pF disc capacitors are not as effective at UHF. The amplified signal appears at the drain of Q1 and is fed to double-tuned network L5, C8, C34, L6, and C9 (Z3 and Z4 in higher-frequency units). C8 and C9 are trimmer capacitors that determine the bandpass characteristics of the network. C6 and C7 provide RF grounding for the low end of L5. The spacing of L5 and L6 and the value of C34, part of the PC board, determine the coupling and bandpass characteristics of this network.

At 900 and 1300 MHz, these components are part of the PC board, and C34 has no physical existence, being part of the positioning of the striplines. R28 suppresses any tendency toward parasitic oscillations but is not needed at 900 MHz or 1300 MHz. RF stage gain is about 18–20 dB, including the losses in the tuned circuit networks between the antenna input and the mixer input. Gain is somewhat lower at higher frequencies. Q2, a BFR90, serves as a mixer. Q2 is biased by R5, R6, R7, R8, and chip resistor network R14, R15, and R16. The mixer current is typically 1 mA. RF signal is fed via capacitor C10 to the base of Q2. LO injection is fed to the emitter of Q2 via network C31, L8, and C33 (stripline element Z5 in higher-frequency units) and pad R14, R15, and R16 from LO circuit Q5 and the associated components. C13 provides a low impedance at the IF frequency, 61.25 or 67.25 MHz, for the emitter of Q2. LO frequency is equal to the received RF signal minus the IF (low side). The LO is tuned via varactor C22 and associated components. Mixer gain is typically 10–13 dB. Overall gain so far is typically 25–30 dB.

Next, the IF signal is fed to matching network C11, C12, L1, L2, and C14. The matching network rejects mixer output products above 100 MHz, therefore acting as a lowpass filter, eliminating UHF components. The matching network feeds IF amplifier stage Q3 and Q4, a feedback structure. R10 is a bias resistor, whereas R9 provides termination for the matching network. C16 is a DC block. R11 and R12 set current gain. Overall IF gain is about 6 dB and can be adjusted by changing R11. The IF amplifier directly feeds a 50- to 75-ohm load. Maximum converter IF output is around –2 dBm for 1 dB compression. This is 150–200 mV into a load of 50–75 ohms. C18 and R13 provide supply decoupling.

LO signal is generated by Q5, a Colpitts oscillator. R21 bypasses C24 and C25, and R17, R18, R19, and R20 provide bias for Q5. Chip cap C21, the internal base-emitter capacitance of Q5, C21, C32, also stray capacitance of the PC board, inductor L7, trimmer C22, and varactor diode D1 in parallel with C23 make up the resonant circuit for the oscillator. In the 900- and 1300-MHz units, a printed stripline inductor Z6 is used. C23, used only in the 900-MHz unit, provides added capacitance to restrict the tuning range to about 30 MHz. D1 is varied in capacitance by a voltage applied to it, via R22, of 1–8 volts. The bias on D2 determines its capacitance and the resonant frequency of the oscillator-tuned circuit. This actually provides “fine” tuning, the setting of C22 having the major effect on oscillator frequency. C22 changes the oscillator frequency about 100 MHz and is used to set the LO frequency so that D1 can tune the LO over the desired range. This is about 358–380 MHz for the 440-MHz unit, 835–865 MHz for the 900-MHz unit, and 1170–1240 MHz for the 1300-MHz unit. Voltage for D1 is fed through isolating resistor R22 from either of two sources. The first source is the onboard tuning potentiometer R24. R24 provides 1–8 volts from its wiper. R25 sets the low limit around 1 volt. D2 acts as half of a logical OR gate, and R23 and C26 provide a pulldown to

ground and RF bypassing for the varactor tuning voltage. The second source is a tuning voltage derived from a remote tuning setup.

Often in UHF work, the antenna is situated on a tower or mast, and therefore a long feedline is needed to connect the UHF station equipment to the antenna. Feedlines have high losses unless they are special expensive types, and even then losses might still be high. For example, a good-quality and rather pricey (USD \$60–80 per 100 feet) coax feedline such as 9913 has 4 dB loss at 500 MHz. By mounting the downconverter and transmitter at the antenna, this problem can be avoided. DC and IF (60–70 MHz) can easily be handled by cheap 75-ohm CATV cable, such as RG59 or RG6 types, with little loss even over several hundred feet. A DC block network (see Figure 15-19) allows injection of a variable DC supply for power and tuning into the IF feedline. This presents a 10- to 20-volt DC voltage into the IF output connection. C19 blocks this DC but passes IF signal from Q4. L3 passes DC but blocks IF because it is 18 microhenries and has a very high impedance at 60 MHz. The input 10–20 volts is passed to voltage regulator IC1 via blocking diode D7. IC1 supplies the +8 volts DC needed to power the converter circuitry, regardless of input voltage. The 10- to 20-volt input is also supplied to zener diode D6 and diode D5, dropping 9 volts across these diodes, resulting in 1–11 volts across pulldown resistor R27. R6 and clamp diode D4 limit the voltage at the input of D3 to 1–9 volts.

This results in about 0.3–8.3 volts across R23 and C26, and this is fed to D1 via R22, which is about the correct tuning voltage range. Therefore, as the DC voltage on the IF cable varies from 10–20 volts, the converter is both powered and tuned over its frequency range. If operation from a fixed nominal DC source (11–15 volts) is desired, the converter is powered via the DC input and blocking diode D8. In this case, tuning is done with the onboard tuning potentiometer R24.

Note that if remote tuning is used, R24 must be set at its extreme CCW position or full converter tuning range will not be obtained. Also, any hum or noise on the tuning voltage will modulate the LO frequency, causing unwanted FM of the LO signal and therefore the IF signal. The tuning sensitivity of the LO is around 2.5 MHz per volt of tuning voltage at 440 MHz, 3.5 MHz per volt at 900 MHz, and 6–7 MHz per volt at 1300 MHz. Therefore, this tuning voltage must be pure and clean DC. Ten millivolts of hum will result in 25–70 kHz of LO deviation. This will cause FM modulation and possible hum bars in the received picture. Conventional NTSC AM TV signals will be less susceptible to this than FM TV commonly used at 1300 MHz and higher, but hum should not be tolerated because it is not difficult to build clean power supplies with the excellent regulator ICs available today.

After you have read and have a fair understanding of how the downconverters work, you can think about construction. We recommend the purchase of the kits described at the end of the chapter because component selection is fairly critical. Do not substitute parts or change layout unless you really know what you are doing. If you choose to make your own PC board, layout is critical (see Figures 15-4 through 15-12 for construction details). The same parts used by the authors, which are critical at 900 MHz and even more so at 1300 MHz, must be used for comparable results. The trimmer capacitors in particular have stray inductance, and the coupling factor between Z3 and Z4 partly depends on the use of these exact parts. Other parts may require layout changes in the PC board and adjustment of microstrip dimensions and placements. Therefore, we strongly recommend using the kits, especially at 900 and 1300 MHz, for best results. Use good lighting while assembling the transmitter. A magnifier is really necessary. Parts are quite small, especially Q1 and the chip resistors and capacitors used in the RF circuitry. Note that all trimmer capacitors and

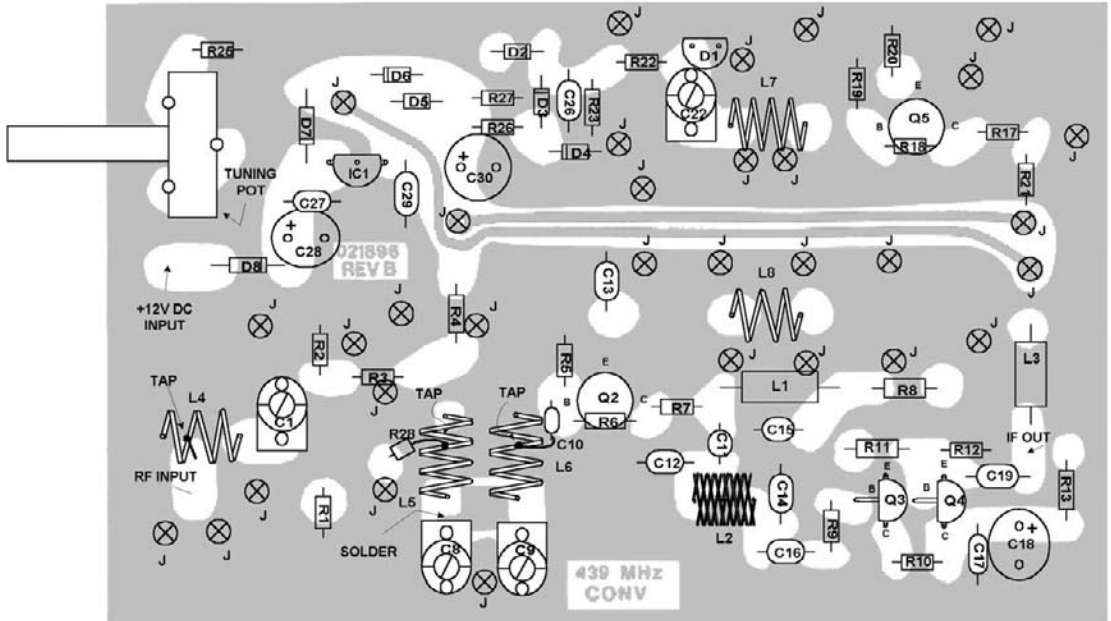

Figure 15-4
ATVC439 Parts Placement Component Side

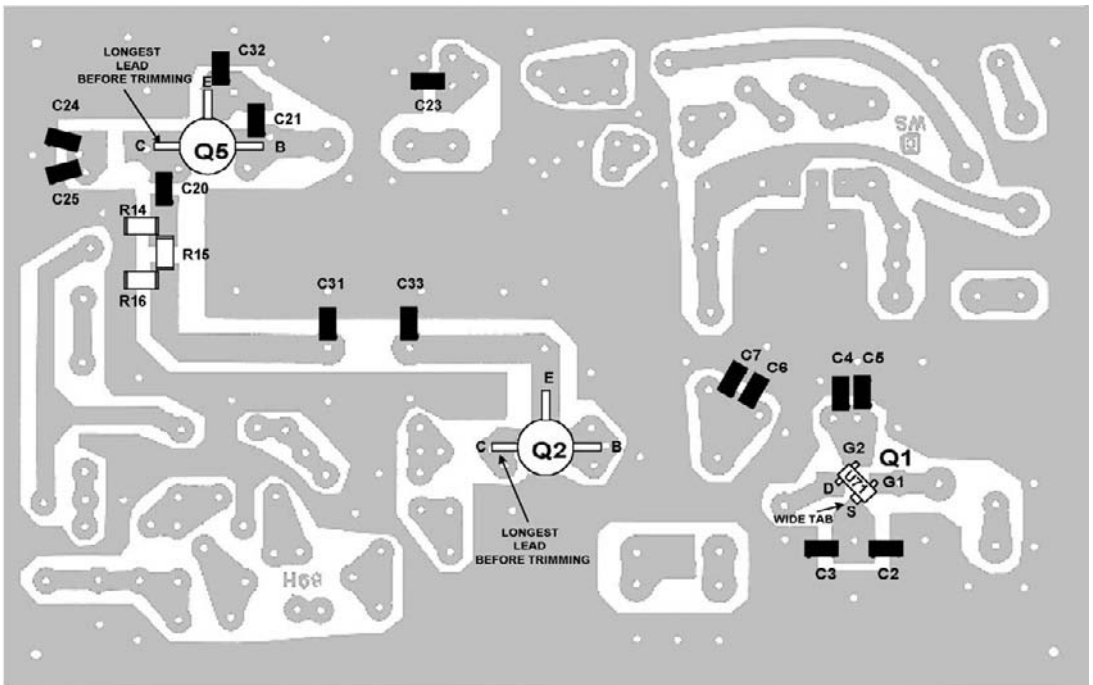
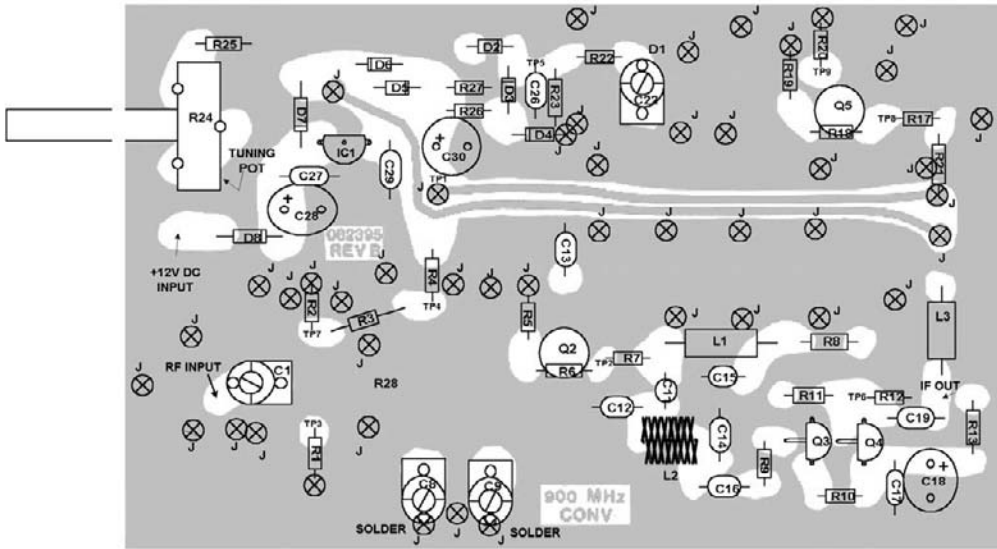

Figure 15-5
ATVC439 Parts Placement Solder Side



IMPORTANT NOTE: TOP AND BOTTOM GROUND PLANES MUST BE CONNECTED AT POINTS MARKED J. SOLDER BOTH TOP AND BOTTOM OF COMPONENT LEAD. IF NO COMPONENT, USE SHORT LENGTH OF BARE WIRE

Figure 15-6
ATVC900 Parts Placement Component Side

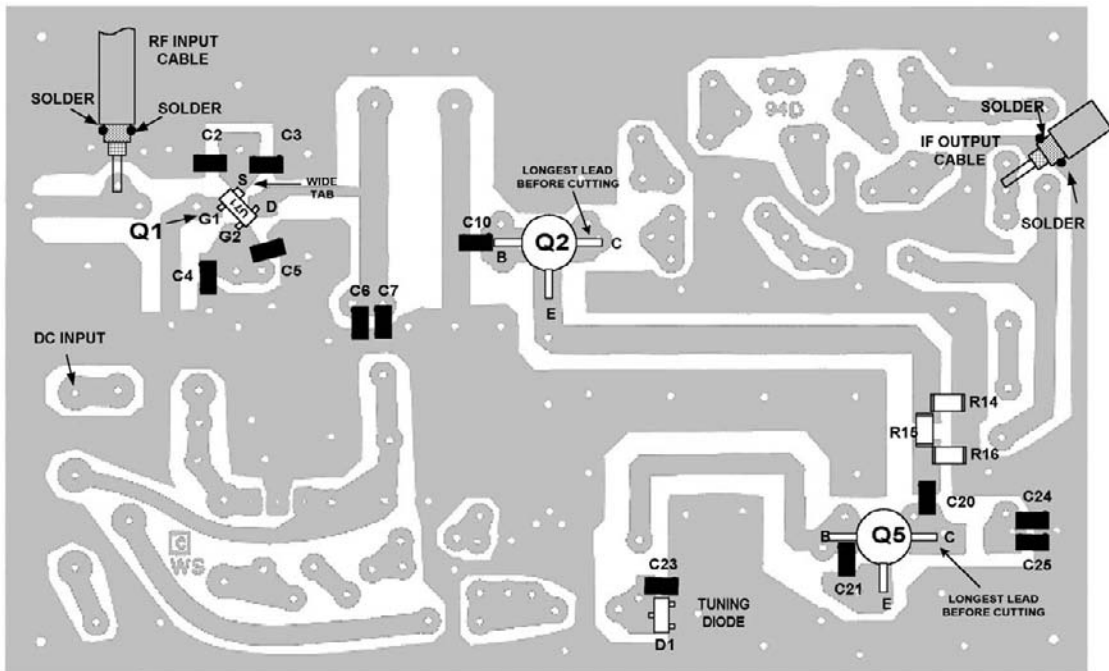
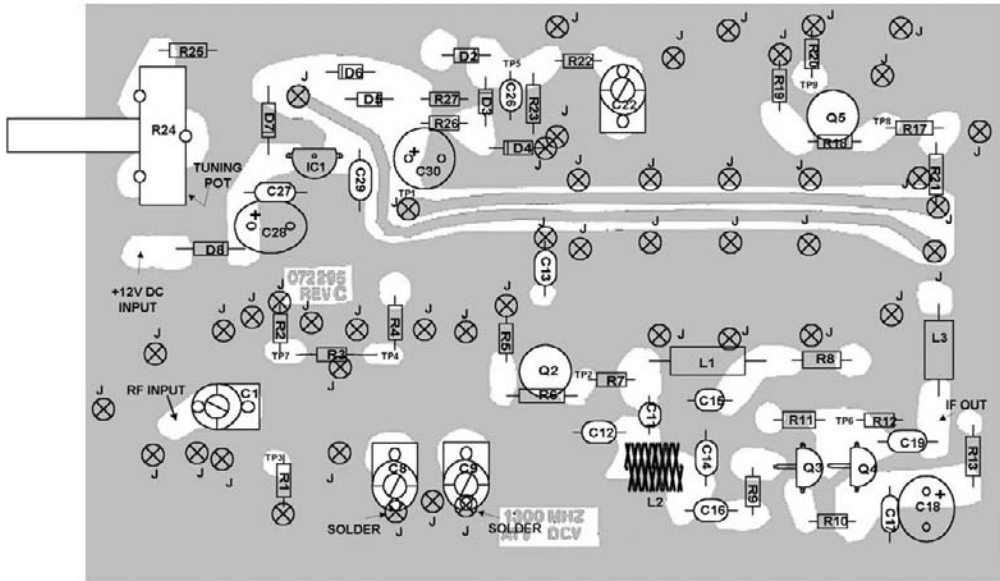

Figure 15-7
ATVC900 Parts Placement Solder Side



IMPORTANT NOTE: TOP AND BOTTOM GROUND PLANES MUST BE CONNECTED AT POINTS MARKED J. SOLDER BOTH TOP AND BOTTOM OF COMPONENT LEAD. IF NO COMPONENT, USE SHORT LENGTH OF BARE WIRE

Figure 15-8
ATVC1300 Parts Placement Component Side

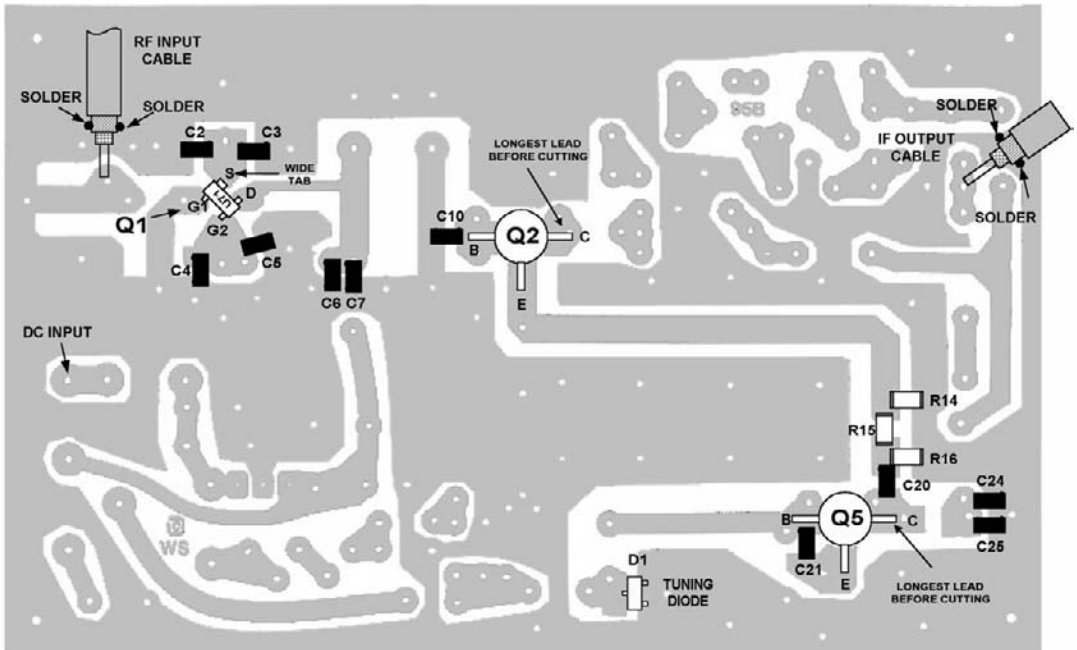
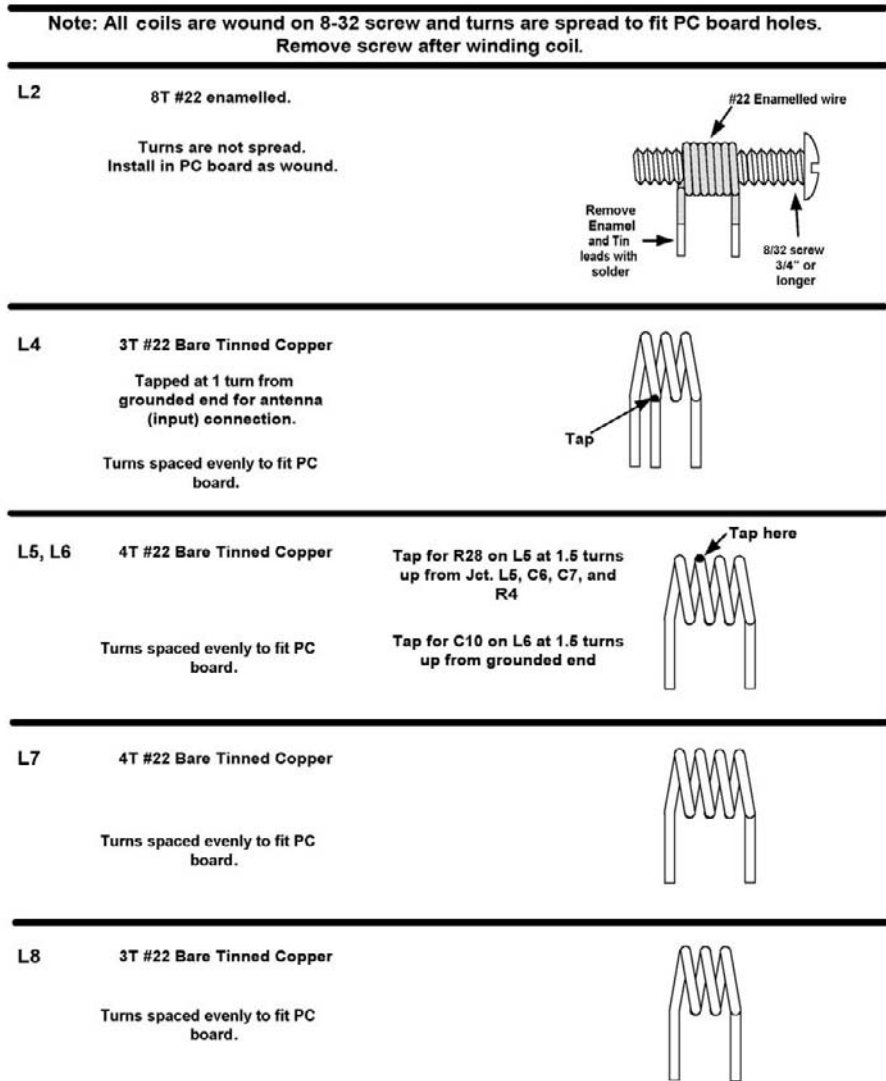

Figure 15-9
ATVC1300 Parts Placement Solder Side

Build Your Own Low-Power Transmitters: Projects for the Electronics Experimenter

Figure 15-10
ATVC439 Coil
Winding Informa-
tion



grounded leads of resistors are to be soldered on both sides of the board. This is essential for good RF grounding. Also note the use of many ground plane jumpers (approximately three dozen). Plated throughholes would eliminate installing these jumpers, but then this PC board would not be easily made at home if the builder wants to make his or her own. Plated throughholes are also a nuisance when components must be removed from the board for service or experiment. (See Figures 15-10 and 15-12 for coil fabrication details.)

The successful tuneup of this device requires either a known signal in the 420–440 MHz, 900-MHz, or 1300-MHz band as applicable, or access to a frequency counter and a signal generator covering this range. You need a known signal of some kind to act as a reference. If you have a low-power TV transmitter, it can be used as a signal source. but remember to use a dummy antenna and keep it at some distance to avoid overloading the downconverter. You will need a suitable TV or monitor tuned to either VHF channel 3 or 4 (an old black-and-white portable TV will do), a

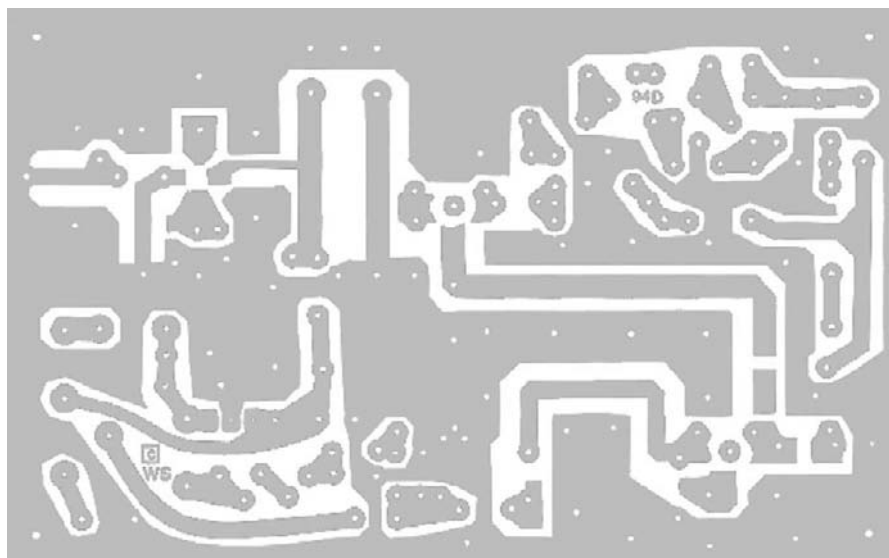

Figure 15-11
PC Board Pattern
ATVC900 Solder
Side

variable power supply capable of supplying 10–20 volts DC at 40 mA or more, preferably with built-in metering, a VOM or DVM, and clip leads and cables as needed. A frequency counter that is reliable to at least 500 MHz is a great help in setting up the LO and finding out where you are during tuneup.

First, carefully check your work for accuracy, component placement, correct orientation, and adequate solder connections. Make sure chip capacitors are correctly installed because a malfunction can destroy the gain of a stage. Also check for inadvertent solder shorts. When you are sure everything is acceptable, connect a source of DC to the 12-volt input (D8 and ground). Ground is negative. No damage or results will occur if the supply is accidentally reversed. Note the current drawn from the supply; it should be around 35 \pm 5 mA. If higher than 40 mA, check for possible shorts. If lower than 30 mA, something may be open or missing. Make the following checks:

1. Check for the voltages listed as follows. Refer to schematics and parts layouts. Unless specifically stated, the negative meter lead is grounded to the negative terminal of the power supply. If discrepancies are noted, check the indicated components. Slight variations outside specified limits may usually be ignored if component checks do not reveal anything wrong; however, if trouble is experienced at a later step with that particular circuit, further investigation may be needed. Remember that the 8-volt regulator has a 5 percent tolerance, which will affect all other readings. Also remember that your VOM could be a few percent in error as well, especially in an older model that has not recently had its calibration checked. Comments after readings indicate what to check if the reading obtained varies significantly from that indicated.

Jct D8, IC2: +11.4 (if NG, check D8)

Jct IC1, C30 (TP1): + 8.0 \pm 5% (if NG, is IC1 in backwards?)

Jct. R4, C6, C7, L5 (TP4): +6.2 to +7.2 (Q1 correctly installed? R4, C6, C7?)

Jct. R1, C2, C3 (TP3): +0.5 to +1.2 (Q1 correctly installed? R1,C2,C3?)

Figure 15-12
ATVC900 and
ATVC1300 Coil
Winding Informa-
tion and RF Cable
Installation Detail

L2 Detail

8T #22 enamelled.
Turns are not spread.
Install in PC board as wound.
Inductance 0.13 uHy
Wind wire in screw threads.
8-32 Screw is removed after
installation.

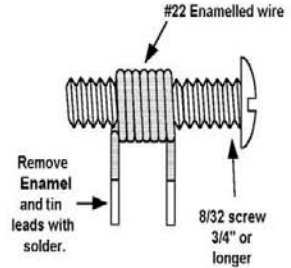
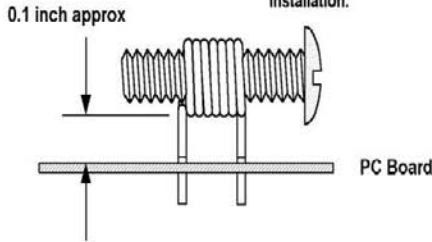

RF Cable installation detail

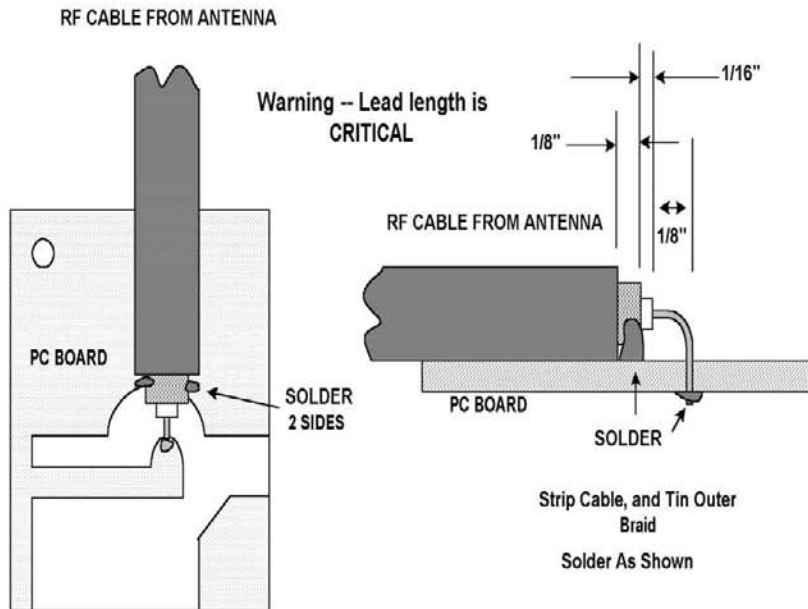

Jct. R2, R3, C3, C4 (TP7): +1.0 to +1.4 (Q1? R2, R3, chips C4, C5?)

Collector Q2 (TP2): +5.5 to 7.2 (Q2, R14, R15, R16, R5, R6, R7, R8, R13, L1, C11, C15, C17, C18)

Jct. D2, D3, C26 (TP5): 0.5 to more than +7.0 (D1, R24, R25, D2, D3, R23, R22 as R24 is rotated)

Collector Q5 (TP8): +6.5 to +7.2 (R21, C24, C25, Q5, C20, R18, R19, R20)

Emitter Q4: +0.8 to +1.0 (If NG, check Q3, R10, R11, R12, C16, C19)

Base Q4: 0.7 volts more (same parts as previous step than base Q3)

2. Set R24 at center. Set C22 so its plates are about three-quarters meshed. Now measure voltage at the collector of Q2. Using a nonmetallic tool, rotate trimmer C22. Some perceptible change should occur in the reading as C22 is rotated from minimum to maximum and back, if Q5 is oscillating. It is not possible to say exactly how much this change will be because it depends on many factors, but it should be readily perceptible on the meter. This step checks out the LO circuit and that the mixer is getting drive from the LO.
3. Nothing should be getting hot. If you experienced some deviation from voltage checks but were not too far off, you may still be okay, but remember the deviation and mark this as suspect if any further problems are encountered. If the following results are successful and the downconverter works well, minor variations can be ignored. Any major variation should be investigated, however, because a problem exists. Make sure that your test equipment is set properly.
4. If steps 1 to 3 are successful, connect a variable voltage supply to the junction of C19 and L3. The positive lead is "hot," and the negative lead goes to ground. Make sure the wiper of R24 is at ground (extreme CCW as viewed from shaft side). Set supply to +11 volts. Check for the following voltages:
TP1: +8 volts DC as before (if NG, check L3, D7, C27, and C28)
TP5: more than +1.2 volts DC (if NG, check D6, D5, R27, R26, D4, D3)
5. Now increase the supply voltage to 19 or 20 volts DC. Repeat step 4 readings. TP1 should still read +8 volts DC. TP5 should be about +9 volts DC. If not, check all components mentioned in step 4. This step checks out the remote tuning circuitry and, if everything is correct, you can then proceed with alignment in the next step.
6. Connect a 75-ohm coax cable to the junction of C19 and L3 (center conductor) and ground (shield braid). Terminate the end of the cable in a connector suitable for your TV or monitor. This is generally a type F connector. Tune the TV to channel 3 or 4, whichever is unused in your area, and set controls for normal reception. If you have a sensitive RF millivoltmeter, use it as an output indicator instead of a TV set because it is easier to interpret. Connect a signal source to the downconverter input and ground. Use a 50-ohm low-loss cable and keep connections *short*. The source can be either a generator or an antenna. Preset all trimmer caps (there are four) to the settings shown in the presets figures. Set R24 to center position. Connect +12–14 volts DC positive lead to D8, negative lead to ground. Keep the bottom of the PC board at least 1/2 inch above any metal. Note that in addition to metals, wood, plastics, and other dielectric materials may also cause detuning. A set of four 1/2-inch or 3/4-inch standoffs installed in the four corner holes is ideal for this purpose. Use only a nonmetallic tuning tool for all adjustments. Plastic tools with very small metallic inserts may work but could also cause a slight error because they add a small but significant capacitance.
7. Activate the signal source and *slowly* rotate C22 until some indication of reception is seen on the monitor or RF voltmeter. Use a fairly strong signal at first. On confirmation of reception, decrease the signal until just enough is generated for a reliable indication. As you remove the tuning tool from C22,

undoubtedly some detuning will occur. You will have to compensate a little to get the tuning correct when the tool is removed. If you have a frequency counter good at 500 MHz (1.3 GHz for higher-frequency converters), you can use it to simplify this step. Next, couple the counter to Q3, staying at least 1/2 inch away from C22 and Q3, and set C22 for an LO frequency in the center of the appropriate band (372, 850, or 1205 MHz) \pm 3 MHz with R24 centered. You must have a steady, not a wildly jumping reading. You may have to experiment with the coupling method, depending on your counter. We found loop coupling to be a little easier than the factory-supplied whip antenna that came with our counter. *Do not* connect any probes, cables, or wires directly to the oscillator circuit or any of its components. The counter may be connected to the emitter of Q2 through a 220-ohm 1/8 or 1/4 watt resistor, but this may detune the oscillator 5–10 MHz; however, with certain counters that are low in sensitivity above 400 MHz, this might be the only way to get a steady, reliable reading.

You can later compensate for this deviation by touching up C22 once you are “in the ballpark.” Once you have a steady reading and you are reasonably sure it is valid, the next step is to check the LO tuning range. Rotate R24 through its entire range. For the 420–440 MHz band, the LO should cover 358.75–378.75 MHz (assuming channel 3 IF). For 900 MHz, the LO should cover 838.75–868.75 MHz, and for 1300 MHz, 1168.75–1238.75 MHz. Note that most ATV activity on 440 MHz is between 426–440 MHz. Similarly, 910.25 MHz or 922.25 MHz is common on 900 MHz, whereas 1277.25 or 1289.25 is used on 1300 MHz, although this rule is not hard and fast, and may vary in different geographic areas of the country, often because of local preferences or the possible presence of interference on some frequencies. It is desirable to keep the tuning range as narrow as possible to improve the tuning rate and ease of tuning. Adjust C22 as necessary to ensure desired coverage. The turns of L7 can be spread or squeezed together with C22 to alter the tuning range. This is fixed on 900 and 1300 MHz and not possible. For other IF frequencies, the LO tuning range can be shifted lower (higher IF) or higher (lower IF). Note that the LO must be *below* the signal frequency or the IF signal will have its spectrum inverted with respect to the input signal spectrum. This will cause difficulties in reception.

If no frequency counter is available, you will have to depend on the reception of a known signal or use a calibrated receiver covering the LO range to pick up the LO signal. A spectrum analyzer can also be used, but most people having access to a spectrum analyzer will probably also have access to a counter. If you have no counter, receiver, or analyzer, don’t worry: use a known signal as follows. First set C1, C8, C9, and C22 to the presets shown in the figures, if you have not yet done so. Set R24 at the center of range. *Slowly* rotate C22 until some indication is seen on the TV or monitor or other output indicator connected to the junction of C19 and L3. Next, confirm that this output is caused by the signal source by shutting it off or disconnecting the input to the converter. If the indication disappears, this is the signal you want. Keep the signal level as low as possible for best results. If you get no results, make sure the signal has not gone off the air and that the monitor, TV receiver, or indicating device is correctly set up and doing what it should.

8. Once you have an indication, peak C1, C8, and C9 for maximum signal as seen on the monitor. You should repeat this step as needed until no further improvement is obtained. Recheck the setting of C22 to ensure that the

correct tuning range is obtained. Check your final settings against presets. They should not be very different from the presets shown if L4 through L8 are correctly made and installed; however, if you are setting up the downconverter for other than the 420–440 MHz amateur band, this may not be true.

9. Your downconverter is now working. Little readjustment of the trimmer capacitors should have been needed, although adjustments may be somewhat “sharp.” Now you can go over the adjustments to further improve performance. If you can get access to a sweep setup, align the downconverter for a flat response within ± 2 dB over the amateur band. This step is not necessary, however, unless you are a perfectionist or just curious. The alignment is simple and straightforward, so do not hesitate to experiment. You should be getting about 40 dB gain and about 1.5 dB noise figure if everything is correct.
10. The downconverter can be mounted in a shielded box with connectors of your choice. We recommend type N, TNC, SMA, or BNC for the input, and for the output almost anything reasonable can be used. A type F is usable for this purpose, but for mast mounting, be sure to waterproof all connections. The alignment should be checked after mounting in any enclosure because some detuning may result. This variation is usually slight, but depending on your exact mechanical configuration, it could be significant.
11. For remote tuning, make sure your variable supply is clean. Any noise or hum will cause FM on the LO signal and a noisy received picture because the tuning voltage is unregulated. Be sure also to set R24 fully CCW when remote tuning is used or the converter’s tuning range will be restricted.

R11 values assume a nominal gain of about 40 dB. Increasing the gain beyond an extra 3 dB is not recommended. Decreasing gain by lowering the value of this resistor is possible, but instability can develop if too much negative feedback is used. To reduce RF gain for very strong signals, it is recommended that a negative bias voltage supply of 0 to -10 volts be applied to TP7 through a 220 K resistor. This can be obtained from a potentiometer that is connected across a -10 volts DC supply. The potentiometer functions as an RF gain control in this case. Reverse AGC from the TV receiver used as a monitor could be arranged to bias TP7 from $+1.5$ volts DC at zero signal to -3.0 volts DC on strong signals. Typically, 35–40 dB RF gain reduction may be obtained using either of these approaches. Because TV receivers vary, the individual circuit arrangements for doing this are left to the ingenuity of the builder.

Another gain reduction method is the use of a manually operated switch to ground TP7. This will reduce RF gain approximately 10 dB. This switch can be a simple SPST switch. For greater reduction of gain, the switch may be connected to a negative voltage of -1 to -3 volts as needed.

Complete parts kits consisting of the PC board and all parts that mount on it, to build these downconverters, are available from the source at the end of this chapter. Please specify which band (440, 900, or 1300 MHz) is desired. Parts for the optional DC block unit are not included in this kit.

Video IF Systems for Use with Downconverters

Few articles have been published on construction of video IF strips in the past. Years ago, the construction of IF amplifiers that were much more than simple 455-kHz AM

radio IF systems was considered to be undertaken only by experienced RF engineers. Even if a good design was then available, sophisticated, specialized test equipment that was not available to the experimenter was needed to set up and align such circuitry. The wide use of prepackaged SAW filters and the availability of excellent IC devices, however, has taken much of the pain and effort out of alignment and setup. The filters have fixed bandwidth characteristics, eliminating the need for alignment. Circuit design has also largely been reduced to a selection of suitable peripheral components to go with the IC devices used, and the IC manufacturers have provided good application notes so “cookbook” designs can be used for most applications. The IF systems to be discussed use these devices to achieve excellent performance with few problems, are readily reproducible with only simple, common test equipment needed for setup, and can be useful for a wide variety of video applications.

One common device available to experimenters at often-low prices on the surplus market is a video modulator. If you have audio and video signals, but your TV or monitor has no direct video and audio inputs, this device will interface things for you. All you have to do is make connections and tune your TV set to channel 3 or 4; however, you often have the reverse problem. You have a TV or cable signal but need baseband video and audio. In this case, the situation is more complex and not as easy to implement. You could use a tuner and IF strip from a junked TV receiver, but probably the necessary supply voltages and control signals needed will have to be supplied by still more equipment. A VCR can also be used for this purpose, but a VCR is large and expensive and few experimenters want to tie up their family VCR.

This chapter describes the design and construction of some IF strips to provide video and audio demodulation of channel 3 and 4 video-modulated RF signals, or a straight 44-MHz IF system for use with a TV tuner and a 70-MHz IF for FM TV. FM TV is used for satellite uplinks and downlinks, terrestrial microwave TV transmission, and amateur television (ATV). These IF strips are designed for hobbyist, amateur, experimental, or professional use and will, with suitable downconverters or other RF front ends, provide the functions of a complete video and audio tuner for both commercial and amateur television. These IF strips directly interface any video device or RF front end with 44 MHz, 70 MHz, or VHF channel 3 or 4 output, depending on the circuit used, with a standard NTSC monitor. They are referred to as the IF44, IF70, and IF66, respectively. With a slight modification, any input from channel 2 to 6 can also be accommodated on the IF66 model.

Although many TV sets and VCRs provide baseband video output, the IF66 IF strip provides the same function in a much smaller package with lower power requirements and avoids tying up a more expensive video device that would otherwise be needed for this purpose. The 70-MHz FM model is useful for FM TV reception of wireless video links, such as described in Chapter 14, amateur TV transmissions, FM, and as a component in experimental amateur microwave TV transmission. FM TV can be used to advantage in the 902–928 MHz band and all higher-frequency amateur bands. There is not enough space in the 420–440 MHz ATV band used for AM TV work; therefore, FM TV is not allowed in this band. The output signals are standard 1-volt point-to-point negative sync 75-ohm NTSC video and 0.5 volts rms hi-Z (approximately 5Kohm) audio line-level signals, and also reverse AGC output (IF44 and IF66) to directly interface with 440-, 900-, and 1300-MHz ATV downconverters previously described in several past issues of *Electronics Now*. The IF strips are designed for NTSC signal operation and will directly drive most monitors, camcorders, and other video devices. If needed, AFC voltage is

available on the IF44 and IF66 models and can be used for LO control of the front end LO if required. AFC is defeatable with a switch connection to ground. Other applications of these devices include use in ATV equipment, in ATV receivers and repeaters as a receiver IF, strip, video distribution systems, security applications and closed caption television (CCTV) for use as a demodulator, and as a video signal source for test and experimental purposes.

The IF44 operates from standard 44-MHz nominal inputs as supplied by standard TV tuner hardware. It has a built-in SAW filter preamp with gain sufficient to compensate for the 20–30 dB loss inherent in TV IF system SAW filters. In addition to the SAW IF filter, an LSI IF amplifier chip is used, and an onboard 4.5-MHz sound IF system is provided. Ceramic filters greatly simplify alignment, and only a signal source, monitor, and VOM are necessary for setup. Gain is typically 70 dB (video out to IF input) and compatible with most 30–40 dB gain TV tuners, enabling adequate sensitivity and signal-to-noise (s/n) ratio. AFC voltage and AGC voltage are available for use with tuners and downconverters.

The IF66 operates from either VHF channel 3 or 4 inputs and can be retuned to operate with channel 2 through 6 IF inputs. It is basically the IF44 with its own input mixer stage and LO, which is AFC controlled, a 44-MHz SAW IF filter, and like the IF44, has an onboard 4.5-MHz sound IF system. Here also, ceramic filters greatly simplify alignment, and only a signal source monitor and VOM are necessary for setting up the IF66. Gain is more than 63 dB (video out to IF input), and the necessary 1–10 mV RF input level (–47 to –27 dBm) is compatible with a typical 30–40 dB gain tuner or downconverter. AFC voltage and AGC control voltage are available for use with various front ends and downconverters.

The IF70 is a general-purpose FM TV IF system operating at 70 MHz and employing LSI IC devices and a SAW filter to eliminate tricky alignment and setup adjustments. This frequency is commonly used for terrestrial microwave FM TV and amateur TV reception as an intermediate frequency. The IF70 will handle FM video link signals, with a suitable downconverter. The IF70 supports FM TV operation with 2–4 MHz signal deviation and uses a standard NTSC sound subcarrier (4.5 MHz) to reduce bandwidth requirements. Further 5.8- and 6.0-MHz operation can be supported by substituting appropriate audio subcarrier filter components. Standard CCIT deemphasis is incorporated, and provisions for video polarity switching are provided. A received signal-strength indicator output is on board, and video and audio outputs are standard NTSC line levels that directly interface with most monitors and other video devices. Signal input levels should be –60 dBm or more to ensure good limiting. This level is no problem with 40 dB gain downconverters. The IF70 directly interfaces with our downconverters described in this chapter for 900-MHz and 1300-MHz reception. Power requirement is either 12-volt AC 60-Hz or 12-volt DC negative ground. Current consumption is about 120–140 mA. PC board size is 2.5 by 4 by 1 inches. Setup is simple with only a DVM and some source of 70-MHz unmodulated carrier needed for setup. Default adjustments are possible for setup, with final setup being done after installation in a system because the two setup adjustments are not critical.

All units operate from 11- to 14-volt DC sources at less than 180 mA. The IF70 power requirement is either 12-volt AC 60-Hz or 12-volt DC negative ground. Current consumption for the IF70 is about 120–140 mA, somewhat less than the other two units. PC board size for all units is 2.5 by 4 inches. Setup is simple for the IF70, with only a DVM and some source of 70-MHz unmodulated carrier needed. Default adjustments are possible for setup, with final setup being done after installation in a

system because the two setup adjustments are not critical. The IF70 is discussed separately for the remainder of the chapter because it is designed to handle FM TV signals and has different circuitry than the others.

Theory of Operation

IF44 and IF66

Refer to the schematics and block diagrams shown in Figures 15-13 through 15-16 for details. The IF44 and IF66 differ only in the input sections. The IF66 is discussed first because it has all of the same features as the IF44. The IF44 differs only in the lack of an input mixer and LO, a simple bandpass amplifier taking their places because no frequency conversion is needed, only straight-through gain. Incoming signal at 60 or 66 MHz (channel 3 or 4) is fed to bandpass filter C1, L1, C2, C3, L2, and C4, which has a broad bandpass of 59–73 MHz at the 3 dB points. The input level should be at least 1 mV for best results. Signal from the input filter is fed to mixer IC1 at pin 1 via C5, and C6 is a bypass capacitor. IC1 mixes the incoming signal with an internally generated LO signal, whose frequency is determined by L3 and the effective capacitance of the capacitor network C7, C8, trimmer C9, C10, and the effective capacitance of varactor D1. This frequency is the sum of the IF frequency (45.75 MHz) and the incoming signal picture carrier (61.25 or 67.25 MHz), so it is 107 or 113 MHz. IC1, an SA/NE602, is a double balanced mixer that produces the sum and difference frequencies, of which only the 45.75-MHz signal is used, the sum frequency being ultimately discarded. D1 is fed a voltage around 3 volts from the

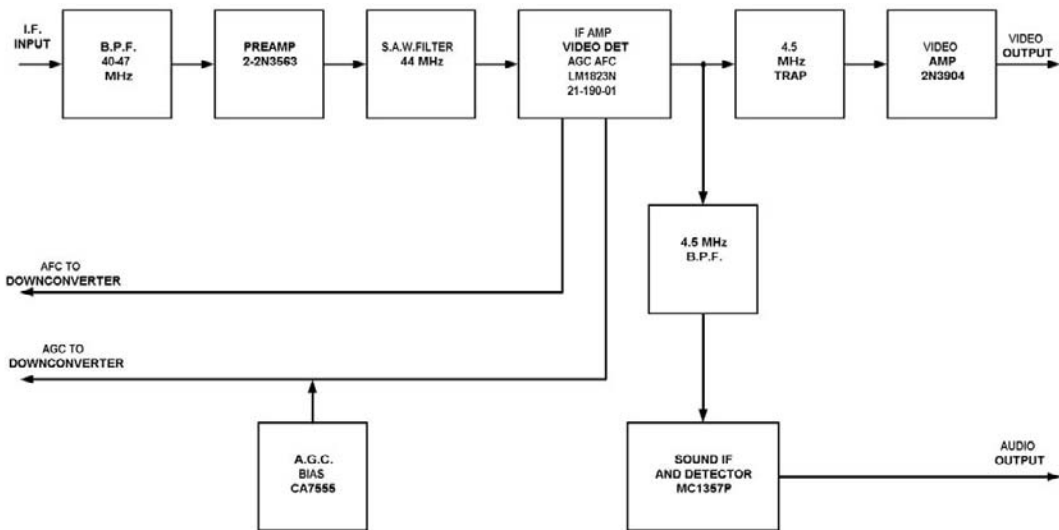

Figure 15-13
IF44 NTSC Video IF System Block Diagram

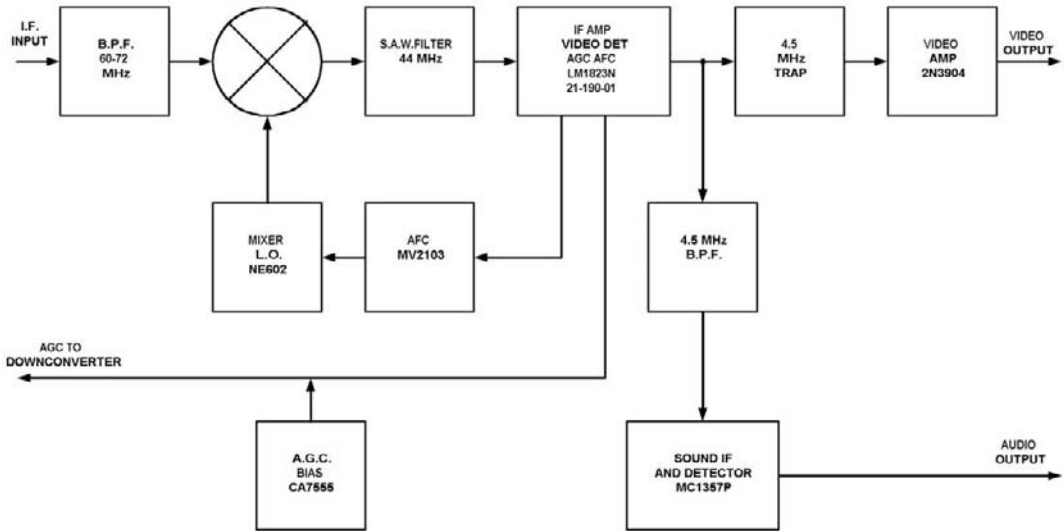

Figure 15-14
IF66 NTSC Video IF System Block Diagram

automatic fine-tuning circuit and maintains the internal LO frequency at nominally 107 or 113 MHz, so the difference signal (IF) is always 45.75 MHz. This signal is fed to Q1, an emitter follower, which provides a match between the high-impedance mixer output and the necessary low-impedance drive for the SAW filter.

In the IF44, an input bandpass filter broadly tuned to 40–47 MHz aids in rejecting out-of-band frequencies (tuner and mixer products) and passes the desired 44-MHz IF signals to input SAW preamp Q4 and Q1. These transistors are used in a shunt feedback pair and provide 23 dB gain and a low-output impedance to drive the SAW filter. Gain is set by R3 and R1. Beyond this stage, the IF44 and IF66 are almost identical. We refer to the IF66 for the rest of the discussion.

The SAW filter has an insertion loss of around 20 dB, which is normal for these devices. IC2, an LM1823, contains a five-stage IF amplifier, a video detector, and an AFT circuit and provides more than 60 dB of gain. Alignment is simple because the system bandpass is fixed by SAW filter FL1. The IC uses a PLL detector for the video and a quadrature detector for the AFT circuit. C28 and L6 form the detector-tuned circuit for the video, and L6 is simply adjusted for best locking as shown by video output and 4 volts at pin 18 of IC2. L4 and L5 are the limiter and AFT detector coils; L5 is adjusted for maximum limiter output at pin 25, whereas L4 is adjusted for 3 volts at TP2 simultaneously with the best received picture, as is discussed in the alignment section. The AFT circuit can be disabled by grounding TP1.

AGC circuitry is set up with level control R18, and the AGC voltage produced is determined by R12, R11, R13, and a bias supply consisting of IC4 and its associated components. Because negative-going AGC voltage is needed, a negative bias is generated by IC4, which acts as a squarewave oscillator running at 25–35 kHz. IC4 is a CMOS version of the well-known 555 timer IC. It is set up with RC network R15, R16, and C15 as an astable with close to a 50 percent duty cycle. The squarewave

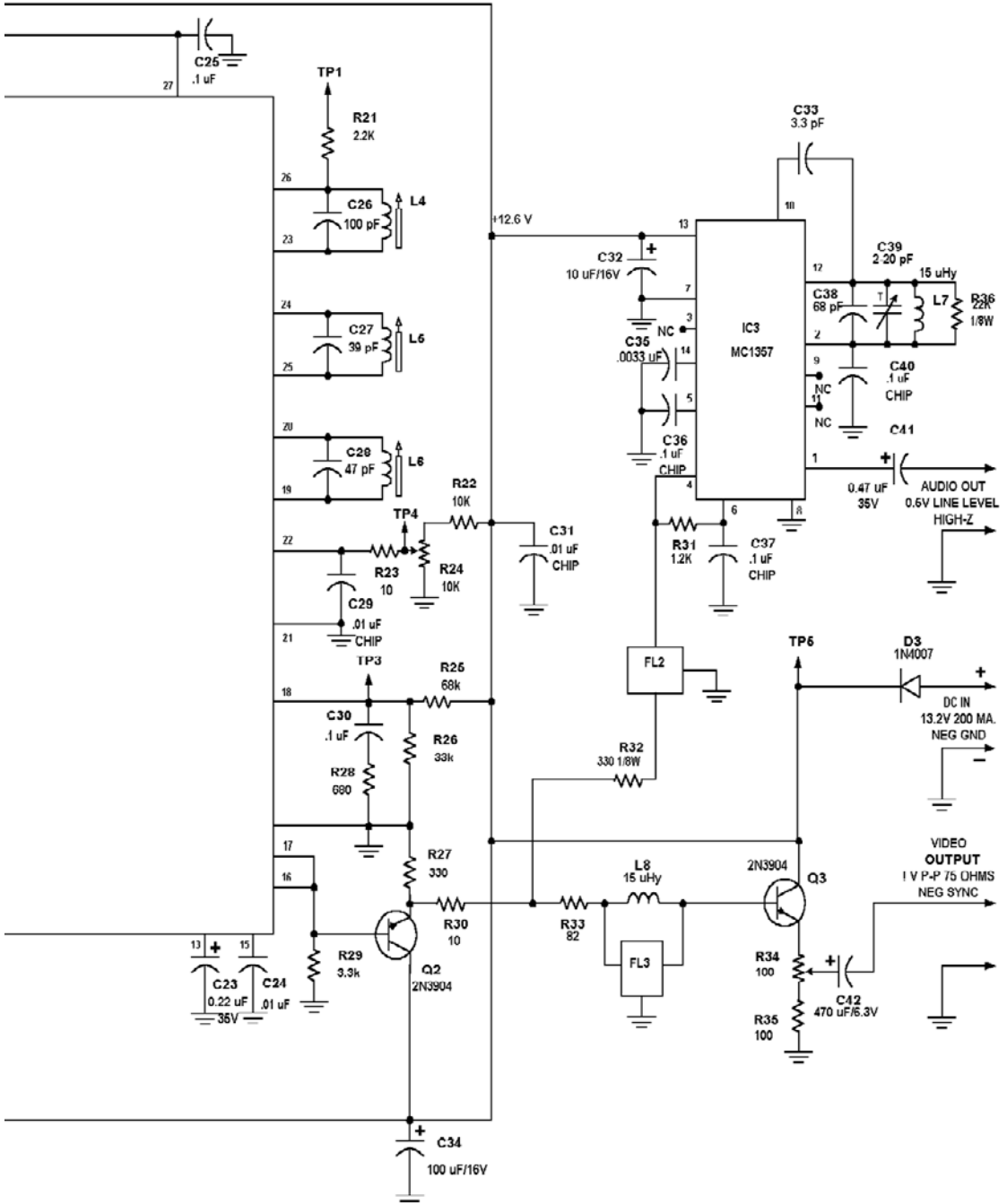

distributed internally, and R18 is used to set the internal threshold of this circuit. R18 is set to avoid overload on strong signals, but not so low to cause premature gain reduction of the external downconverter.

Composite video appears at pin 17 of IC2, across load resistor R29, and is about 2–3 volts point-to-point. R30 is an oscillation suppressor. Q2 is an emitter follower,

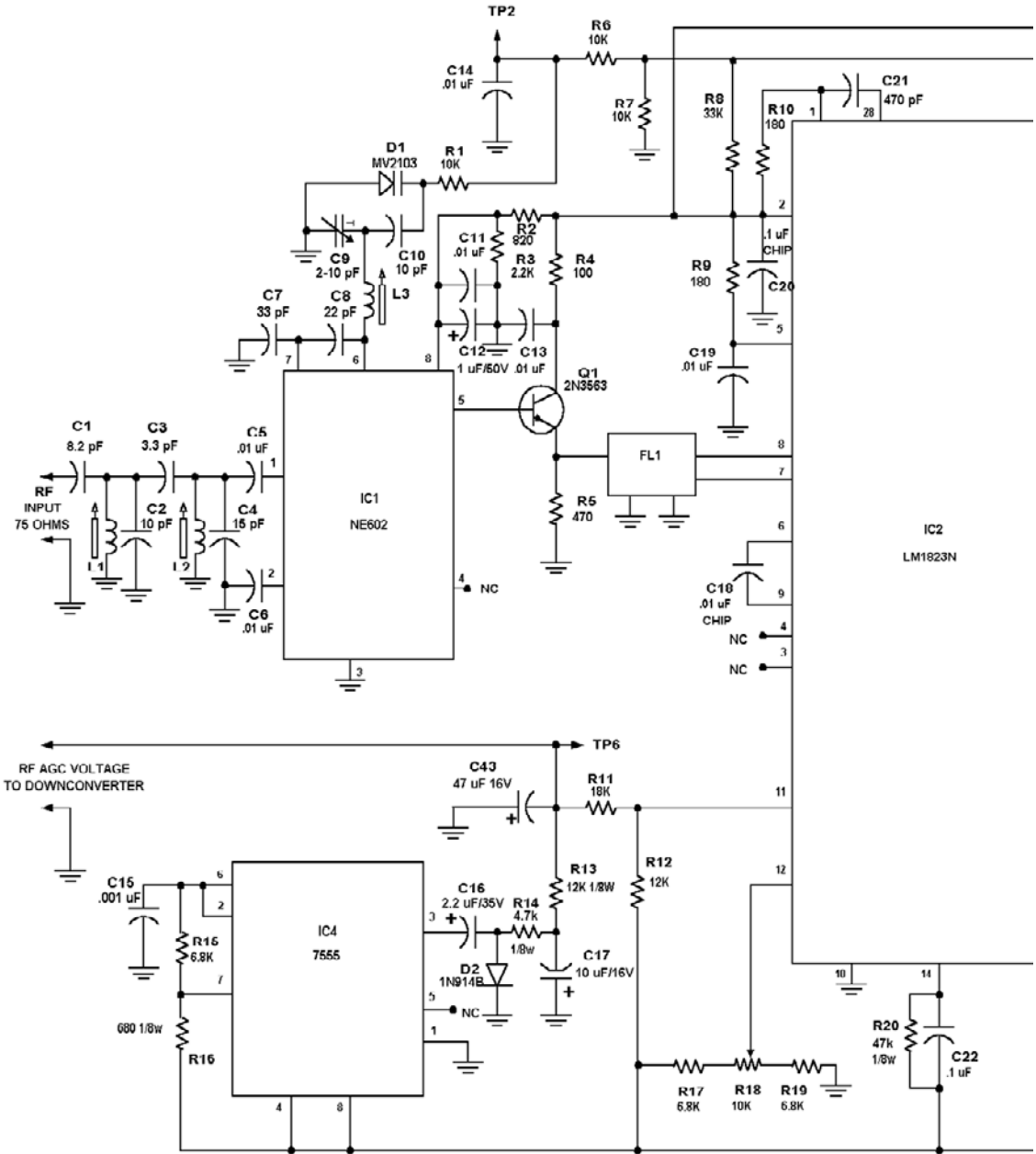
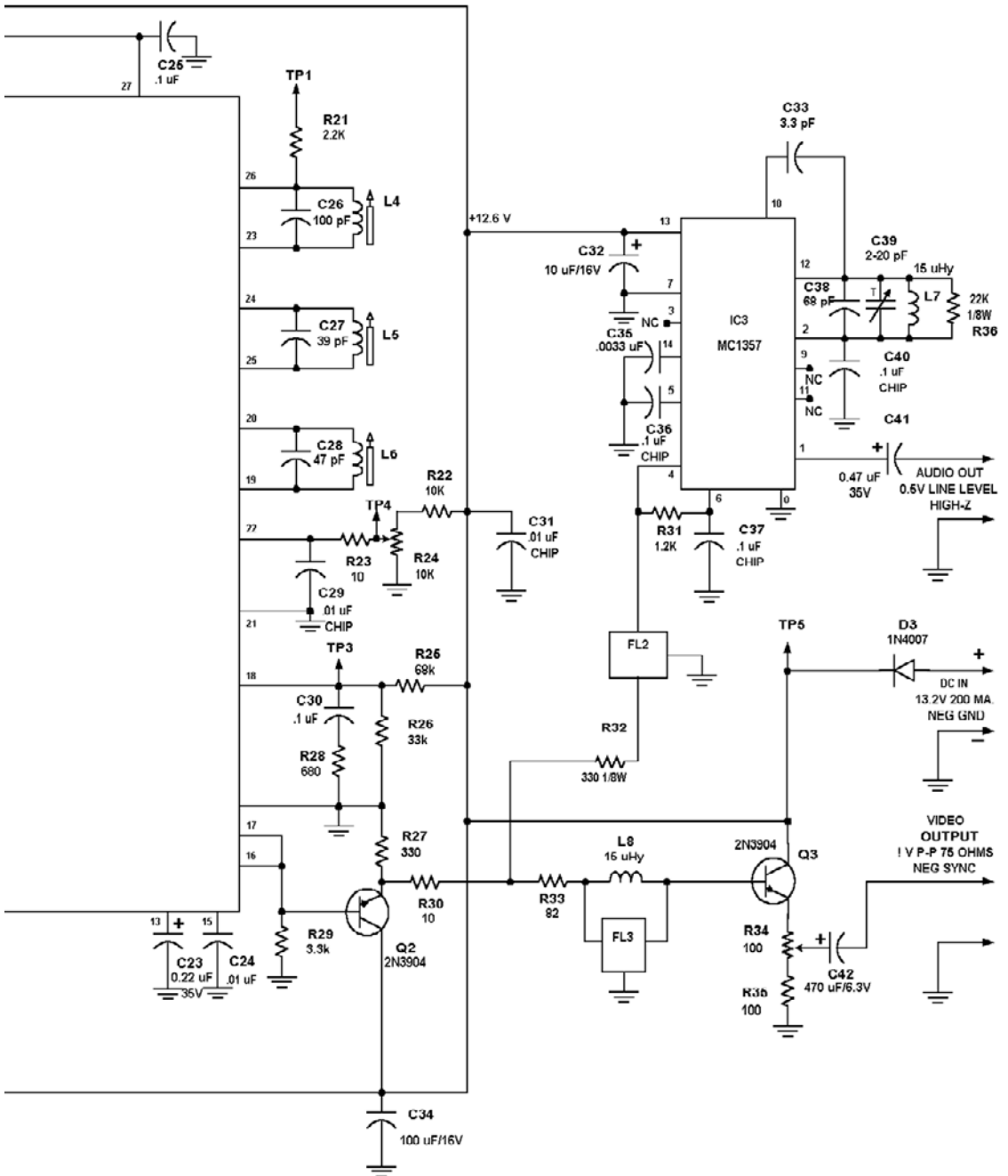

Figure 15-16
IF66 NTSC Video IF System Schematic

which provides a low-impedance source for the video buffer to follow. The composite video is then fed through R32 to the sound IF bandpass filter FL2, which passes only the 4.5-MHz sound subcarrier, and to R33 and trap network FL3 and L8, which rejects the 4.5-MHz sound subcarrier but passes all other video components. This process prevents sound interference patterns in the received picture. Q3 is an output



driver, which feeds potentiometer R34 to set video output level and DC blocking capacitor C42. Video output is 1–2 volts point-to-point across 75-ohm negative sync, which is a standard interface level.

Audio is derived from the 4.5-MHz FM sound subcarrier passed by FL2 and appearing across R31 at pin 4 of IC3. IC3 is an amplifier, a limiter, and a quadrature

FM detector. The quadrature circuit consists of trimmer C38, C39, L7, drive capacitor C33, and R36, which broadens the response. The Q is about 30, which ensures freedom from clipping at modulation (audio) peaks. Audio output is deemphasized by C35 and appears at pin 1. C41 provides DC blocking. Audio level is 0.5 volts RMS into a nominal 5K line load, which interfaces well with most audio amplifiers. Chip capacitors are used for bypassing to reduce physical size of the circuit. Alignment is simply adjusting C38 for the maximum and the clearest audio output.

DC power is nominally 13.2 volts DC negative ground at about 180 mA. D3 acts as a protection diode in case of reversed supply polarity or negative transients that may damage the IC devices. C34 provides supply decoupling and filtering. Supply tolerance is ± 1 volt for best performance. Do not exceed 14.4 volts, and note that less than 11 volts may cause poor performance. Figures 15-17 through 15-25 provide parts layouts, block diagrams, coil fabrication data, and a suitable DC block for downconverter use.

IF70 FM TV

Frequency-modulated television (FM TV) has been around for awhile and offers some advantages over conventional amplitude modulation television (AM TV). AM has been the U.S. standard for commercial TV broadcasting; however, like AM radio, there is somewhat more susceptibility to noise (snow, etc.) under moderate or weak-signal conditions. The picture s/n ratio of a received AM television signal has to be on the order of 25–35 dB for “watchable” reception. This limit is subjective and depends on how poor a picture will be tolerated by a viewer, which also depends on how badly the viewer wants to see the program. Even 40 dB s/n ratio is obviously less than perfect, with 50 or 60 dB desirable for good quality. This implies having a

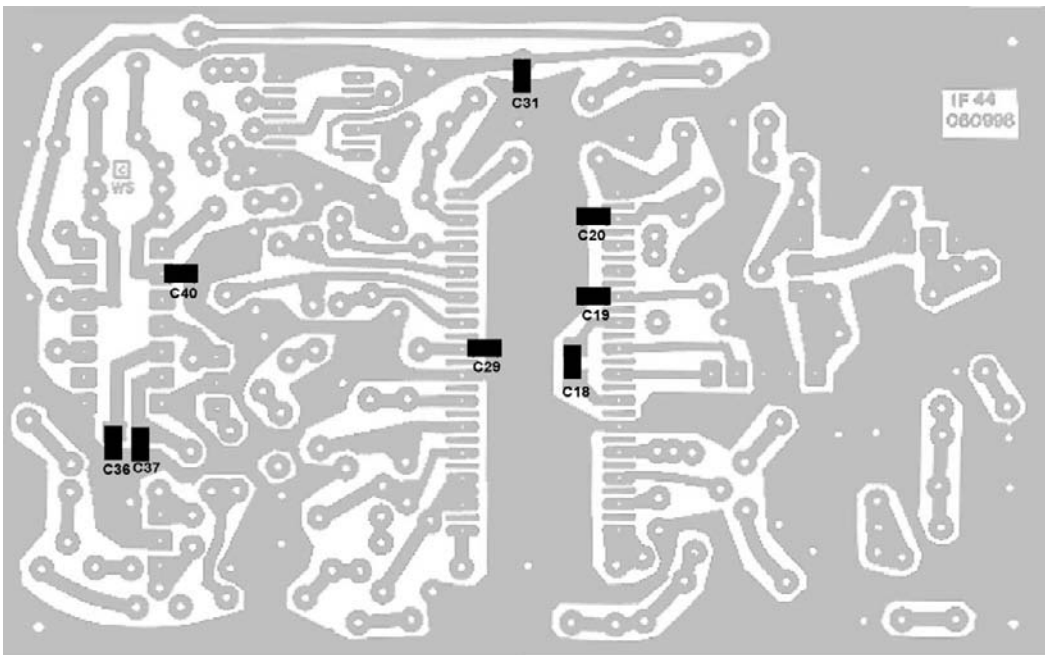

Figure 15-17
IF44 Video IF System Parts Layout Solder Side

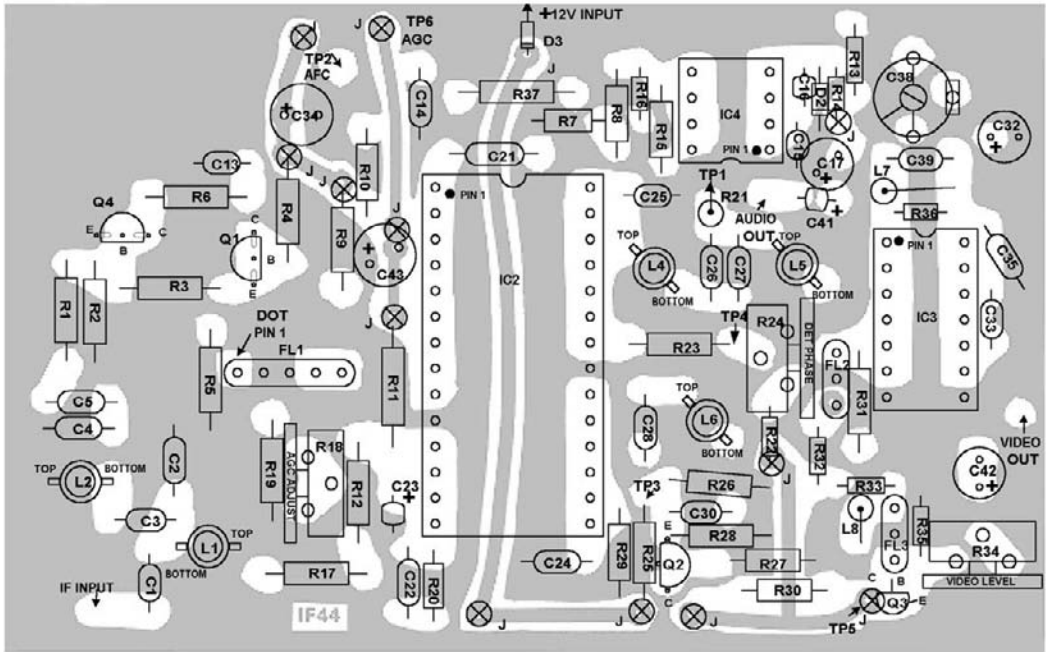

Figure 15-18
IF44 Video IF System Parts Layout Component Side

received signal level in the 1–10 mV range. In a 4-MHz bandwidth, the thermal noise floor is about -108 dBm or about 1.1 microvolts into 75 ohms. Allowing a 4 dB noise figure in the TV tuner RF stage and 4 dB loss in the antenna feedline, the noise floor is -100 dBm at the antenna.

For a somewhat snowy picture, a received signal of -70 dBm (87 microvolts) in 75 ohms is needed, and for a good picture -50 dBm (870 microvolts) or more is desirable. These figures are referenced to 75 ohms. A different reference is often used, such as dBmV, or decibels referred to 1 millivolt. Therefore, with this system, a 1-mV signal into 75 ohms is 0 dBmV, 2 mV would be +3 dBmV, and so on. Cable systems try to deliver at least 0 to +3 dBmV to subscribers for optimum reception on each channel. More is better, but too much can cause interference because of intermodulation in the receiver front end, degrading all channels with herringbones and wavy lines caused by various beat frequencies and intermodulation products produced from inevitable system nonlinearities. This should also be kept 50–60 dB down so as not to be noticed in the picture. This requirement does not sound like much of a problem, but it can be a tall order. Equipment sold for CATV use has to be evaluated for the amount of interference that might be produced before it can be used as a system component. Levels must be carefully adjusted for optimum reception. Too little causes snowy pictures and too much causes interference.

FM TV offers certain advantages over AM TV in a manner analogous to the way FM radio has advantages over AM radio. Better s/n ratios for all signals above system

Build Your Own Low-Power Transmitters: Projects for the Electronics Experimenter

Figure 15-19
DC Block Schematic

In order to take advantage of the downconverter's remote tuning capability, a means of injecting DC into the IF cable is necessary. The IF signal, usually 61.25 or 67.25 MHz (VHF channel 3 or 4) must be fed to the TV receiver or monitor with little loss, and the DC on the IF cable must be blocked from reaching the receiver. This circuit will accomplish this function. The entire assembly must be built into a shielded metal case, and the DC input at J3 must be well bypassed. These precautions are necessary to avoid stray signals at the IF frequency from leaking into the receiver, which can cause interference with reception. A small metal case, and a few components, two F or BNC connectors, and a suitable power connector (J3) can be mounted in a small enclosure as shown.

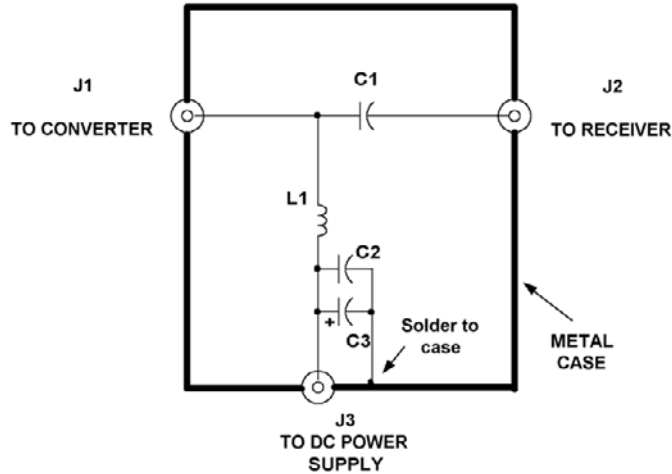

Parts List DC Block

- L1** RF choke good at 66 MHz. 10 to 33 microhenry values are suitable
- C1, C2** 470 pf Disc Ceramic
- C3** 1000 uF 25 WV or higher
- J1, J2** Suitable connectors (F or BNC suggested)
- J3** DC power connector (any suitable)
- 1 ea** Metal enclosure, RF tight, to suit

threshold are obtained. This threshold level is typically -95 to -85 dB when the carrier-to-noise (c/n) ratio is around 8 dB for FM TV systems used in satellite TV broadcasting. The “knee” is very pronounced, and 1–2 dB increase in ratio may improve the picture 6–10 dB or more depending on receiver characteristics. The transmitter power of an AM system is a function of the video signal level, being maximum at video black level. As anyone who has worked with photography knows, picture defects, such as film grain (high-frequency noise) and mottling or unevenness in tones (low-frequency noise), are most obvious in middle to lighter gray tones. In video, these are the values or levels approaching white where the transmitted power is 10 dB or more below peak, effectively decreasing the s/n ratios for these levels. This agrees with practical experience, snow being less noticeable in the darkest and lightest areas of the picture.

The transmitted TV signal is very “delicate” with regard to interfering conditions. Interference 20 or 30 dB below the received signal can degrade or even ruin reception. In contrast to AM TV, FM TV transmitters always run at constant power output. The capture effect in FM systems tends to reject interference from stray signals

Figure 15-20
IF44 Coil Winding
Information

All coils are made with #22 enamelled wire and are wound on 8-32 screw thread.

L1, L2	9.5 Turns
L3	Not Used
L4	5.5 Turns
L5	10.5 Turns
L6	7.5 Turns

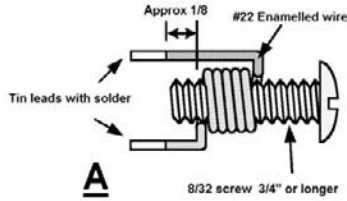

- A) Wind coil on 8-32 screw used as a mandrel.
- B) Form leads as shown in (A).
- C) Scrape off enamel from leads and tin as shown in (A).
- D) Install in PC board using screw as a holder as in (B).
- E) Remove screw from coil by rotating counterclockwise.
- F) Thread in slug as in (C). Coil inductance depends on slug position and will be set at tuneup.

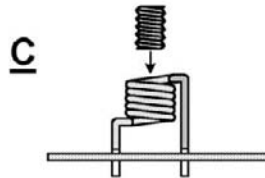
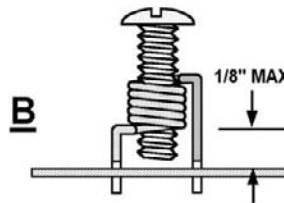

present in the channel. An interfering signal 10 dB lower than the desired signal may hardly be noticed in an FM system, but in an AM system it causes severe interference; however, multipath interference such as ghosting is annoying in an AM system but may totally destroy FM reception because of severe distortion of the received video waveform. AM TV may have the advantage when multipath interference is a problem; however, FM TV is used mostly at UHF and microwave frequencies, where antenna directivity largely eliminates this multipath problem.

FM TV has been used for many years for satellite TV work. In this application, weak signals have been the rule because available power on board the satellite is restricted. Effective radiated power (ERP) levels are in the 10 watt to 1 kW range, unlike the hundred odd kilowatt levels employed in terrestrial broadcasting. Distances of 22000 miles must be covered, contrasted with 50–100 miles in terrestrial work. Path loss can be calculated from the well-known equation $P.L. = -(37 + 20 \log F + 20 \log D)$ dB. At the frequencies used for satellite TV (4 GHz), this is 196 dB. An ERP of 500 watts is equal to +57 dBm. With a satellite dish antenna having a gain around +43 dB, about -96 dBm of signal power is available for the receiver. With a good low-noise amplifier (LNA), this is just enough to allow a 10 dB s/n ratio assuming an LNA 1 dB noise figure. In the case of an FM system, this would be a fairly decent, watchable picture with a few “sparklies” because we are 2 dB or so

Figure 15-21
IF44, IF66 PC
artworks

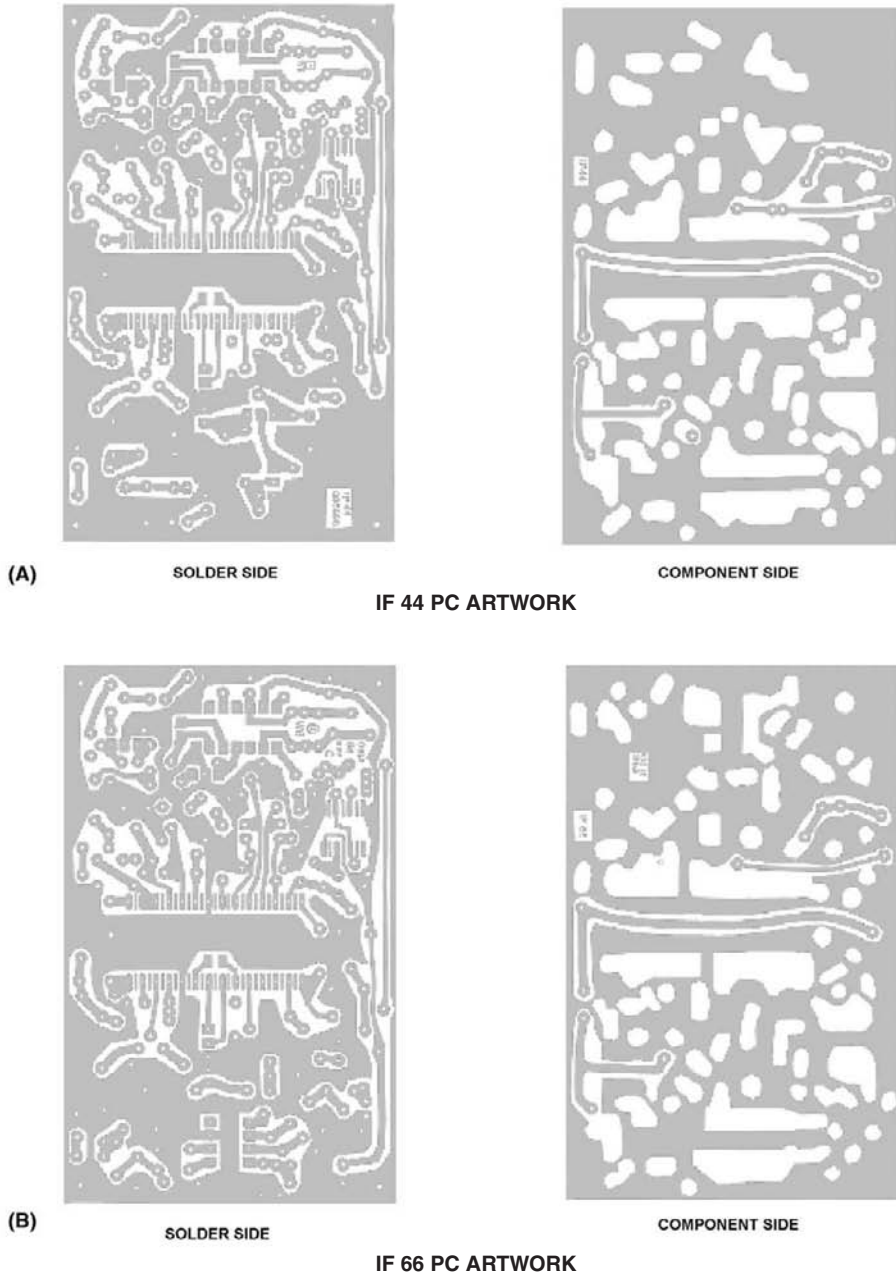

above threshold. A 10 dB ratio in an AM system would produce a barely detectable image that might occasionally sync the receiver. Another 20 dB of signal would produce a snowy picture, but this would take an antenna 10 times larger in diameter to receive it. Hundred-foot dishes are somewhat impractical for home use, and even for program distributors, are not very feasible. In this example, the advantages of FM TV are obvious.

FM TV requires wider bandwidth, however. Satellite TV uses bandwidths of 30 MHz per channel. Strictly speaking, signal bandwidth must be determined from the modulation index and Bessel functions, using a table or by calculating the allow-

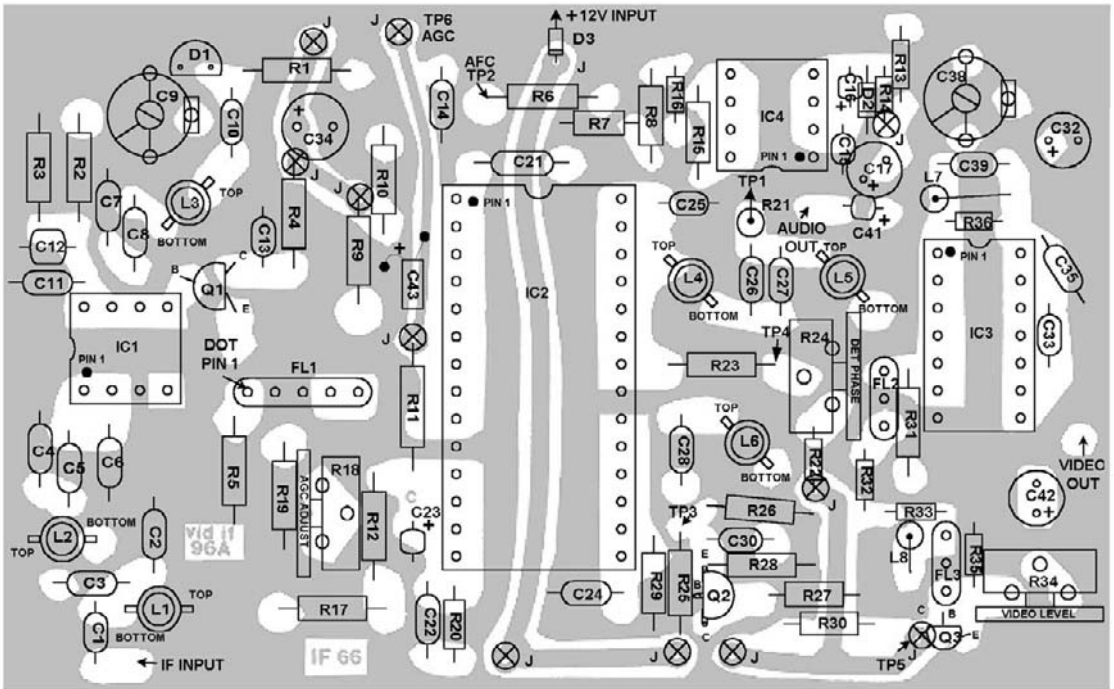

Figure 15-22
IF66 Video IF System Parts Placement Component Side

able loss of significant sidebands. A simplifying rule of thumb that is found to work in practice in FM receiver design is that an FM receiver needs a bandwidth of twice the signal deviation plus the highest modulating frequency. Mathematically, this is equal to $(2D + F_{mod})$. Therefore, a stereo FM receiver used with standard 75-kHz FM broadcast deviation needs at least $2 \times 75 + 53$ kHz (53 kHz is highest MPX frequency component), or 203 kHz. In order to avoid distortion and allowing for drift, 220–270 kHz is used. Two-way 5-kHz FM voice (300–3000 Hz audio), as commonly used for business or public service radio, would need $2 \times 5 + 3$, or 13-kHz IF bandwidth. Satellite TV uses about 10–12 MHz deviation and a 6.8-MHz audio subcarrier, plus other subcarriers up to 8 MHz, and therefore needs up to 30-MHz IF bandwidth.

This is no problem at microwave frequencies, but it would pose a problem at terrestrial UHF frequencies in the 470–806 MHz range. For amateur TV work in the 1240–1300 MHz band, the deviation can be kept to 2–4 MHz. If audio is needed, 4.5 MHz could be a better choice than the 5.8-, 6.0-, or 6.8-MHz sound subcarriers used for FM TV, terrestrial microwave, and satellite work because slightly less bandwidth is needed, and readily available 4.5-MHz TV components may be used. The commonly encountered 920-kHz beat problem between the sound and color subcarriers is easily overcome by using a ceramic 4.5-MHz sound trap and maintaining

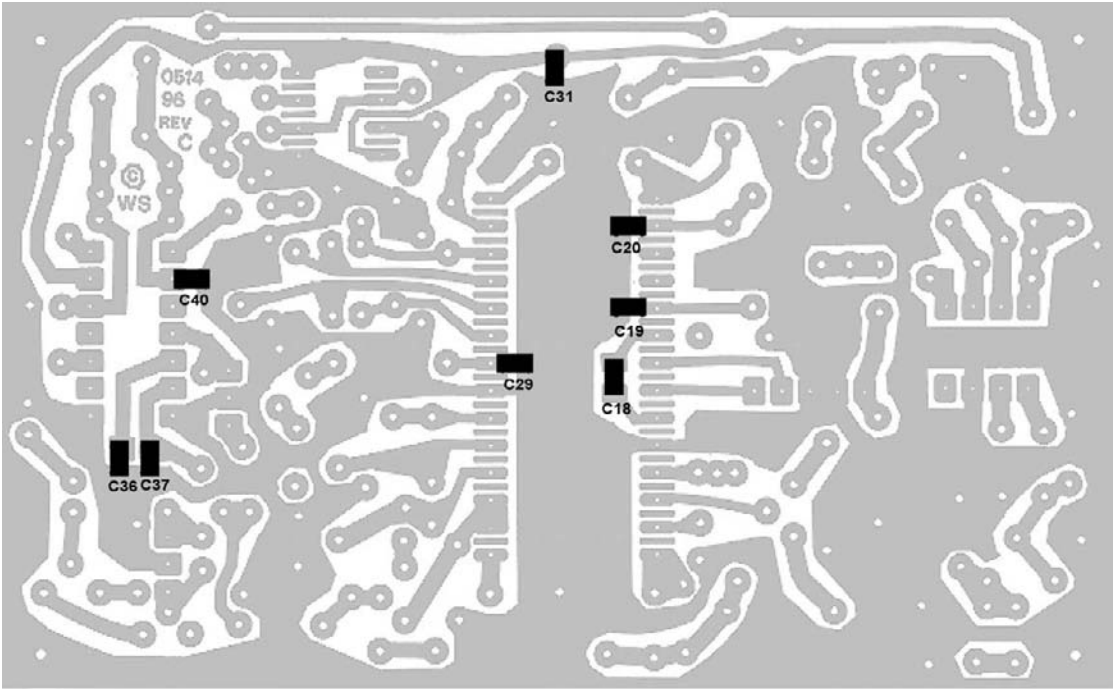

Figure 15-23
IF66 Video IF System Parts Placement Solder Side

good system linearity. This allows 2–4 MHz deviation to be used with a 4.5-MHz audio subcarrier. An 11-MHz wide (Siemens X6950) SAW filter is available for 70 MHz. We designed and built this IF system for experimental FM ATV work. Currently, other standards are used in some areas (5.8-, 6.0-, or 6.8-MHz sound), and old satellite receivers are used as receivers, but they are really too wide in bandwidth for use with 2–4 MHz deviation signals. Anyway, the circuitry is still the same, and the parts may be changed to accommodate other standards, but because no FM ATV activity is currently present here in northern New York state, we felt free to set our own standards around components we had on hand. With narrower deviations, the advantages of FM start to disappear, and wider deviation would occupy excessive band space.

The IF system to be discussed is built around Motorola MC13155D IF amplifier system chips (see Figures 15-26 and 15-27). These ICs are supplied in an SO-16 surface-mount package and can operate to 300 MHz. The chip contains a three-stage amplifier, a limiter, and a quadrature detector. Power requirements are 3–6 volts at 7 mA per chip. Referring to the schematic, IF input at 70 MHz is applied to a preamplifier stage consisting of Q1, Q2, and associated components. R1 and R2 set the gain at 25 dB, which is enough to compensate for the loss in SAW filter FL1. A 1:4 transformer T1 and R5 terminate the SAW filter and provide a balanced drive to amplifier IC1. Input pins are 1 and 16. The amplifier output appears on pins 7 and 10. Chip capacitors are used to provide good decoupling and bypassing at the 70-MHz frequencies used in the system. Gain of the first stage is about 46 dB. A DC level of about 0–3 volts appears across R6, with signal levels of 70 μ V to 70 mV, and

Figure 15-24
IF66 Coil Winding
Information

All coils are made with #22 enamelled wire and are wound on 8-32 screw thread.

L1, L2, L3	9.5 Turns
L4	5.5 Turns
L5	10.5 Turns
L6	7.5 Turns

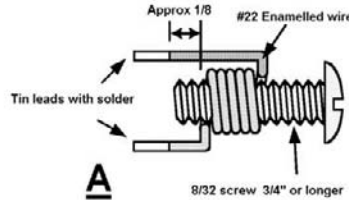

- A) Wind coil on 8-32 screw used as a mandrel.
- B) Form leads as shown in (A).
- C) Scrape off enamel from leads and tin as shown in (A).
- D) Install in PC board using screw as a holder as in (B).
- E) Remove screw from coil by rotating counterclockwise.
- F) Thread in slug as in (C). Coil inductance depends on slug position and will be set at tuneup.

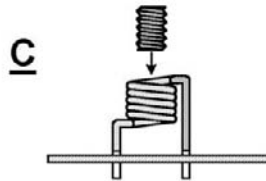
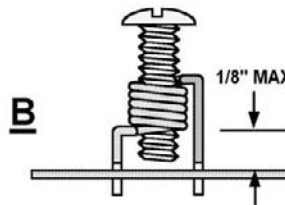

has a pretty near logarithmic response, about 1 volt per 20 dB increase in signal. This could be used as a received signal strength indicator (RSSI).

Attenuator R8 to R11 helps maintain this characteristic and RF stability. IC2 is configured as a limiter and quadrature detector to recover the video information. C16 and C17 couple limiter output to the quadrature network L1, C18, and R12. R12 provides damping of the network to obtain a low-Q, wide-bandwidth response. Q values used may vary from 2.5 to 5, depending on bandwidth needed. We used a Q of about 5 in the network shown. Differential recovered video output is available at pins 4 and 5 of IC2, and R13, R14, C19, and C20 limit video bandwidth and reduce 70-MHz IF feedthrough to the video amplifier stages to follow. R7 provides bias for the RSSI circuit, and R6 provides a pullup for the RSSI output. A supply of -5 volts is used for IC1 and IC2. The supply is negative to obtain effective RF grounding without elaborate RF decoupling and bypassing. This is no inconvenience because both $+5$ volts and -5 volts are needed for the video op-amps IC3 and IC4. A charge pump DC-DC converter IC9 produces negative voltage for IC8 because only about 35 mA is needed at -5 volts.

The video output appearing at pins 4 and 5 is amplified in the first video amplifier IC4. IC4 is configured as a differential amplifier with a gain of 2 and produces a single-ended output. The output of IC4 is fed to a video deemphasis filter R21

Figure 15-25
 Preamplifiers for
 IF66 Off-the-Air
 Reception of TV
 Channels 2-6

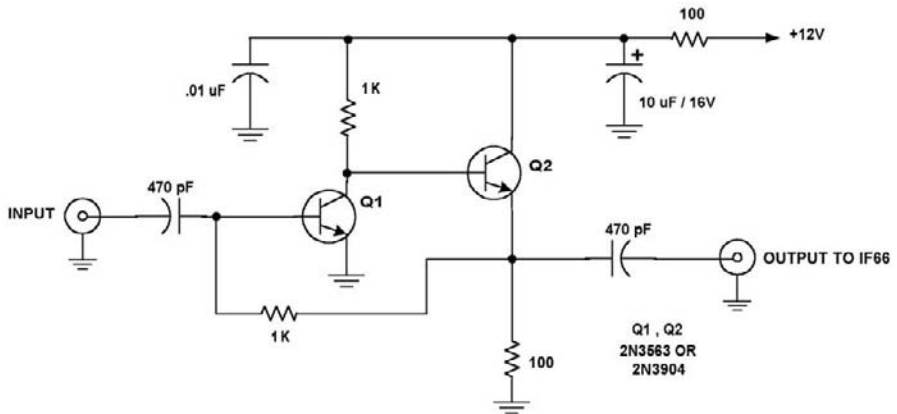

(A) DISCRETE TRANSISTOR CIRCUIT

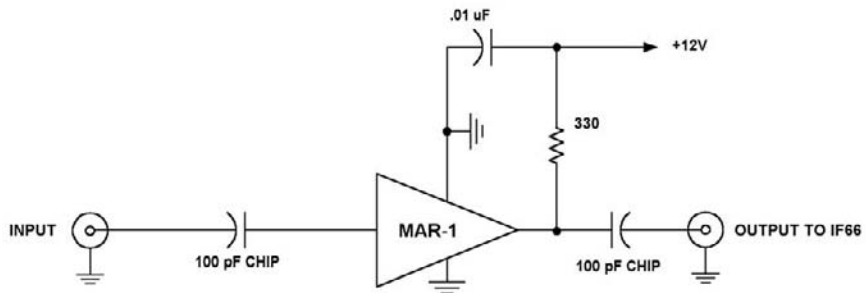

(B) MMIC CIRCUIT

through R27, C33, and L4. Deemphasis corrects the frequency distortion that is deliberately introduced into the transmitted video as a means of obtaining improved s/n ratio of the FM video system. The crossover frequency (0 dB gain or loss) is 716 kHz, and the curve is a standard one used for FM TV work, analogous to the audio preemphasis method that is used in FM audio broadcasting. FL3 is a ceramic band reject (notch) filter and rejects the sound subcarrier to reduce the possibility of sound to color beat interference patterns (4.5–3.58 MHz, or 920 kHz) in the video. L3 is part of the rejection circuit and passes the lower-frequency video components. Another ceramic filter (FL2) passes only the sound subcarrier components. This may be an LC filter or, in our case, a fixed tuned ceramic filter. R19 and R20 provide proper termination for the respective filter networks.

The audio subcarrier is amplified, limited, and detected by a conventional quadrature detector circuit using a MC1357 IC, which is specifically designed for this purpose. The center frequency and bandwidth is set by C28, C29, L2, and R36. The setting of trimmer C29 determines the center frequency, and R36 controls the Q value of the quadrature network to provide linear FM detection of the 4.5-MHz

Receiving Converters and IF Systems for Low-Power ATV Transmitters

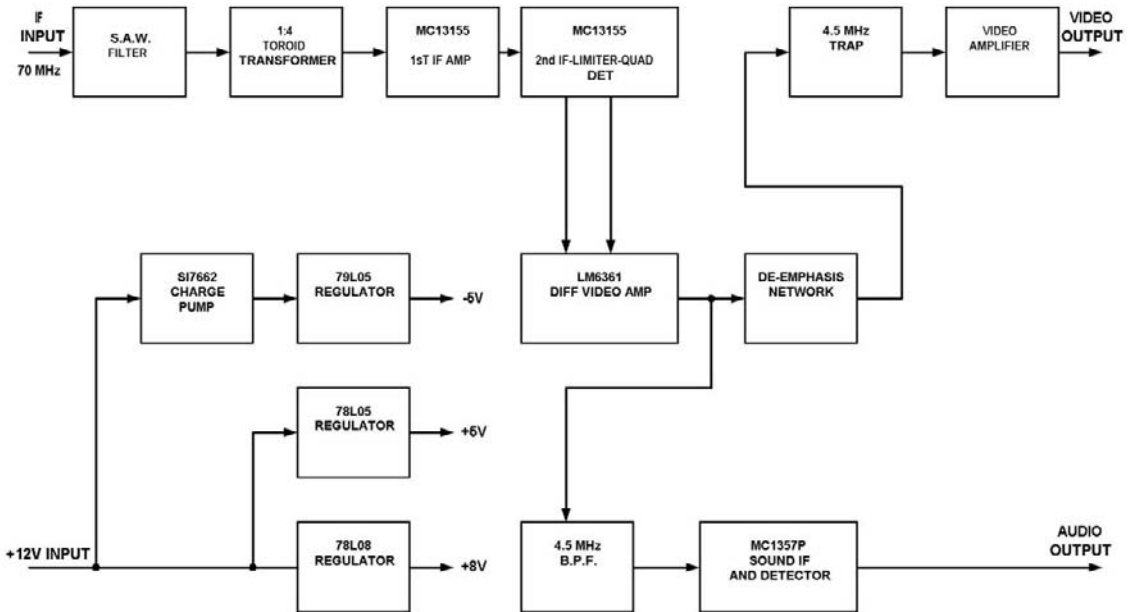

Figure 15-26
IF70 Video IF System Block Diagram

audio subcarrier. Approximately 25-kHz deviation is generally used. Audio output is around 0.5 volts RMS into a 5K load for full subcarrier deviation. This interfaces well with most audio line levels.

Depending on modulation polarity, downconverter circuitry, and the effect of any frequency mixing, the output signal can be either sync polarity negative or positive. Generally, black-to-white, low-to-high frequency modulation is used, but because receiving system frequency translation schemes can change this order, some means of video polarity selection has to be provided. The output of the video deemphasis and audio reject network is fed to a jumper block on the PC board. A jumper is used (JP1) to connect video to the inverting or noninverting input of the second video amplifier IC3. If desired, a SPDT switch may be connected here if polarity will be changed often. This amplifier stage has a gain of two. It consists of IC3, resistors R28 through R32, and C35. An LM6362 video op-amp is used, and the output feeds video buffer Q3-Q4. This provides current gain and can drive a 75-ohm load with up to 2V p-p video. C34 couples video to the output of the IF system. This video is unclamped (no DC component), and some clamping may be needed to restore DC (brightness) levels at the interface, depending on whether the particular device has clamping circuitry or not.

Regulator ICs IC6, IC7, and IC8 supply the +5, +8, and -5 volt DC levels needed to power the circuitry. D1 and C36 supply unregulated DC of more than 10 volts to the regulator ICs. Because a negative supply is needed, charge pump IC9 acts as a DC-DC converter and can derive a negative voltage from a positive supply. About -10 volts is produced, which is sufficient to drive regulator IC8 to produce -5 volts for the circuitry. The charge pump uses C41 and C37 as storage capacitors to transfer charge and reduce switching noise.

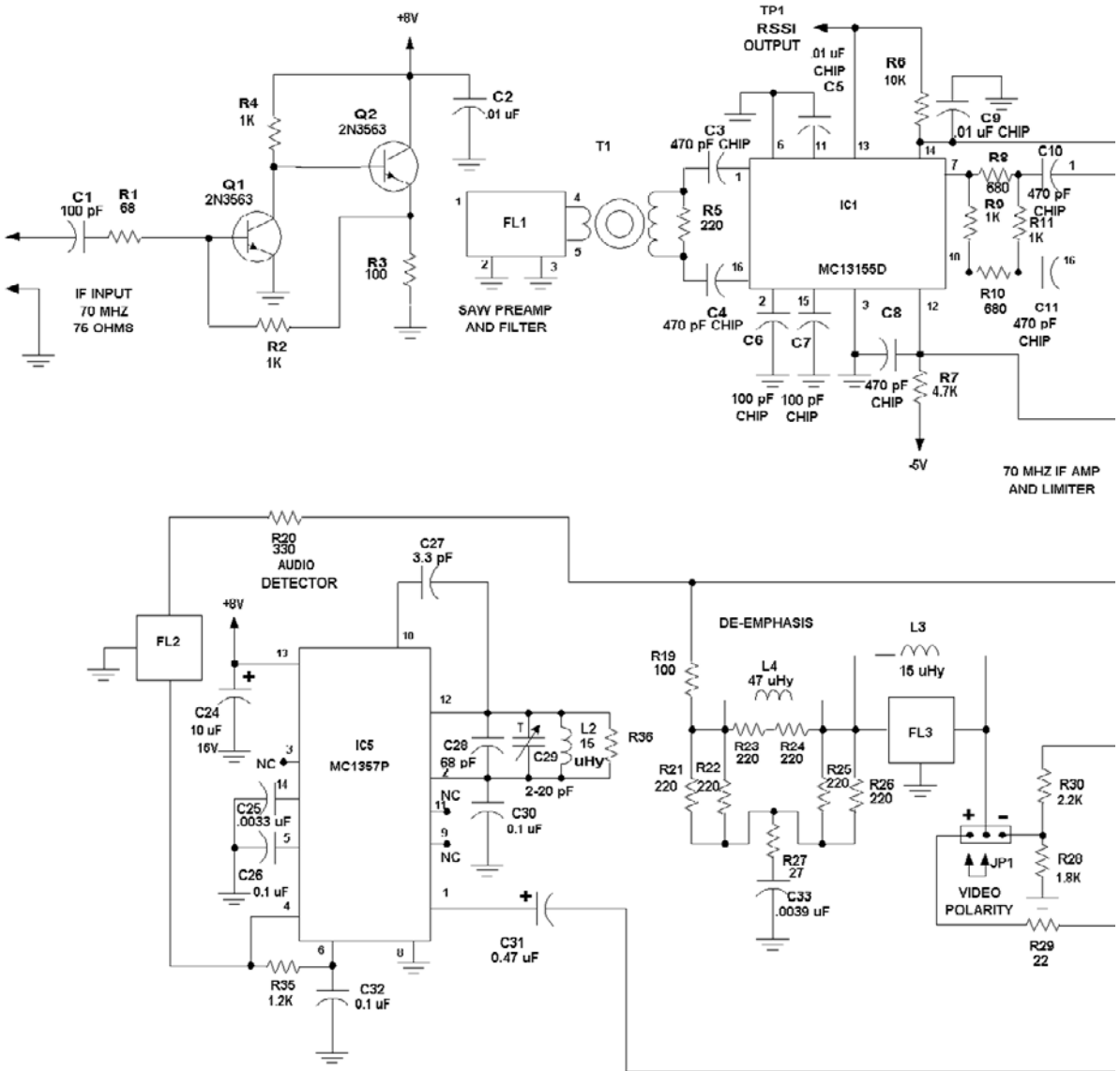
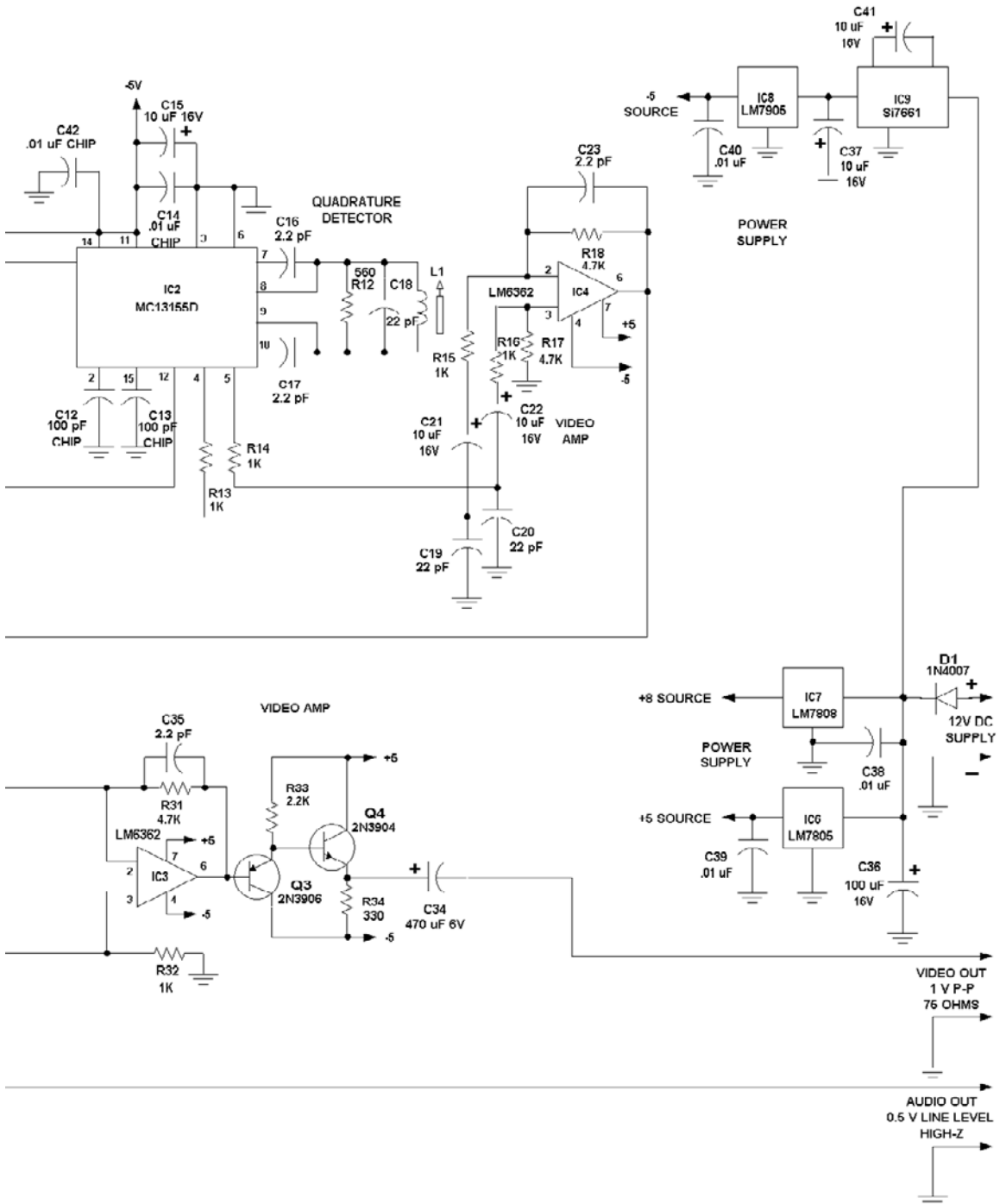

Figure 15-27
IF70 Video IF System Schematic

Receiving Converters and IF Systems for Low-Power ATV Transmitters



Build Your Own Low-Power Transmitters: Projects for the Electronics Experimenter

Before beginning construction, familiarize yourself with the circuitry. IC sockets may be used if desired, but make sure low-profile kinds are used so IC leads are kept short. Excess lead length and socket capacitance may cause instability and other problems such as video ringing, glitches, and/or oscillation that yield poor results. Note that trimmer cap C9 (IF66 only) and the grounded leads of some resistors are to be soldered on both sides of the board. This step is essential for RF grounding. Use rosin core solder, with low residue preferred. *Do not* use acid core or any paste fluxes. A hot, 25–40 watt pencil iron is best (see Figures 15-10, 5-12, and 5-30 for coil fabrication details).

Tuneup

IF44 and IF66

The successful tuneup of the IF44 and IF66 IF strips requires a known NTSC TV signal (VHF channel 3 or 4), or some source of 44-MHz IF signal in the case of the IF44. A 44-MHz IF signal can be obtained from a surplus TV tuner taken from a junked TV set if a TV signal generator is not available. You will have to power up the tuner and connect it to either a cable system or outside antenna. Set the tuner to a known TV channel that has a good signal. You will also need access to an NTSC video monitor (most computer monitors do not accept these type of signals directly and therefore will not work) or a TV receiver that has an external video input jack

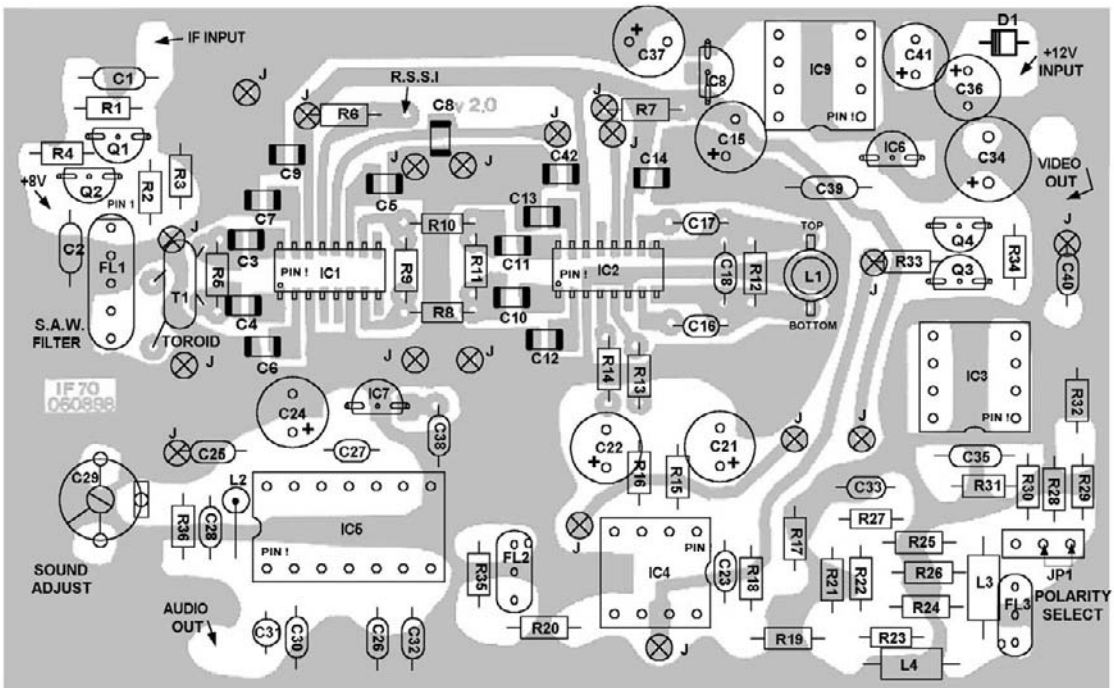

Figure 15-28
IF70 Video IF System Parts Placement Component Side

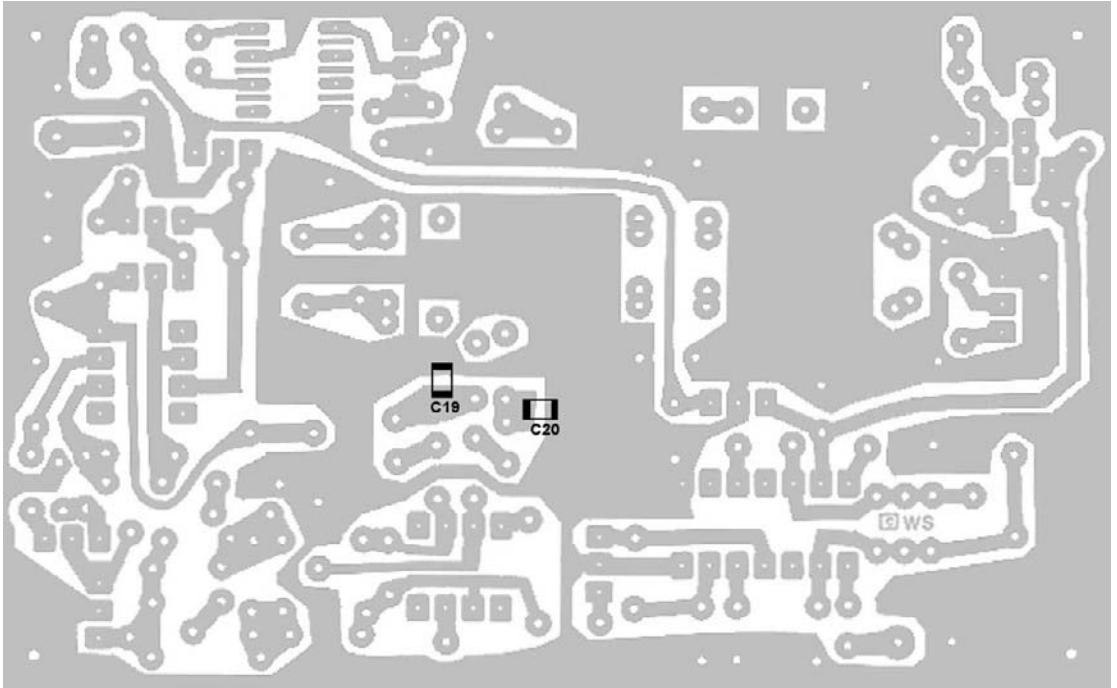
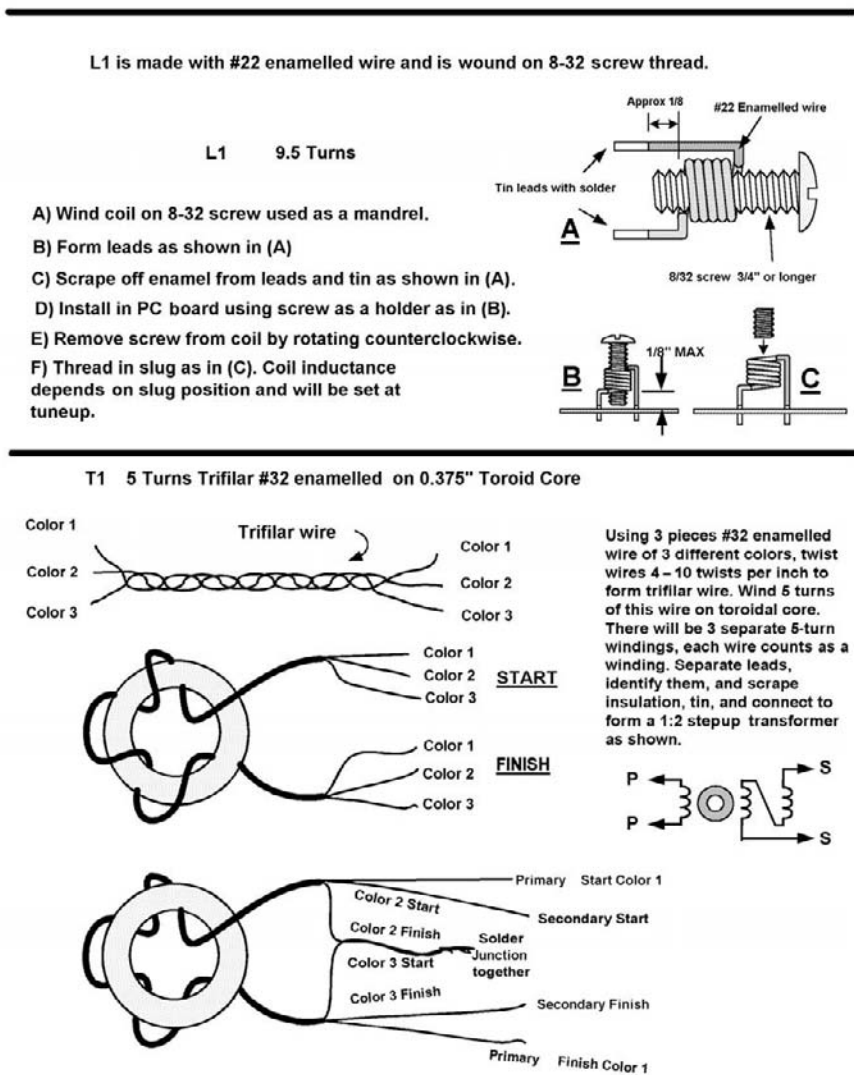

Figure 15-29
IF70 Video IF System Parts Placement Solder Side

(many new TV sets have these) that operates with a standard 1-volt p-p 75-ohm negative sync video input, a VOM or DVM, and a source of +13.2 volts DC with good regulation and at least 250 mA capacity. The power source should have less than 50 mV p-p ripple and noise and an impedance of 1 ohm or less. Better DC supplies sold for powering hobby and experimenter circuits meet these specifications. A fully charged lead acid gel cell, alkaline, or nicad battery can also be used. *Avoid using wall transformers* because they are often poorly filtered and unregulated and may blow out the ICs due to overvoltage.

A VCR makes a good signal source for testing. A metered DC supply is best from a convenience standpoint. Again, note that computer monitors are generally not usable with the video IF unless they accept an NTSC signal directly. Generally, a suitable NTSC-RGB interface box is needed to use most modern computer monitors. In addition, clip leads and cables are necessary for making connections. If you cannot obtain at least these items, find someone to help you. For the IF66, a frequency counter that is reliable to at least 200 MHz or more is a great help in setting up the LO, although an FM broadcast receiver covering 88–108 MHz can serve if a counter is unavailable. If channel 2, 5, or 6 operation is desired with the IF66, it is advised to first set up and test the IF with a channel 3 or 4 input and, after alignment, make the modifications discussed in step 12. In this way, experience can be gained with the circuit, and a standard VCR or signal source can still be used for most of the alignment. The IF44 is a straight-through amplifier, and no frequency counter is needed because there is no LO circuitry.

Figure 15-30
IF70 Coil Winding
Information



A cable box or another video device can be used as a source instead of a VCR, but verify that only channel 3 or 4 output is present at sufficient level (1 mV minimum), with no other spurious output components that could cause confusing results and indications during test and alignment. This setup will work only for the IF66, not the IF44.

First, carefully check your work for accuracy, component placement, correct orientation, and good solder connections. Make sure that chip capacitors are correctly installed because a malfunction can destroy the gain of a stage. Also check for inadvertent solder shorts. When you are sure everything is correct, connect a source of DC to the DC input (D3 and ground). Ground is negative. No damage or results will occur if supply polarity is accidentally reversed. Note the current drawn from the supply; it should be around 150–200 mA. If it is higher, check for possible shorts. If it is lower than 150 mA, something may be open or missing from the circuit. Make sure that jumpers in the Vcc rail have been installed and that all top-of-board rails

have been soldered where jumpers or components connect to them. When everything is acceptable, proceed with the following steps:

1. Check for the voltages listed as follows. Refer to the schematic as required. Unless specifically stated, the negative meter lead is connected to the negative terminal of the power supply. If discrepancies are noted, check the indicated components. Slight variations outside specified limits may usually be ignored if component checks do not reveal anything wrong; however, if trouble is experienced at a later step with that particular circuit, further investigation may be needed. Also remember that your VOM could be a few percent in error, especially if an older model is used.

Jct D3, C34 (TP5): +12.6 volts (If NG check D3)

Pin 2 IC2: +12.6 volts and supply voltage

Pin 8 IC1: +7.2 volts +/-1 volt (IF66 only)

Emitter Q3: +6.0 volts nominal, depends on signals

Pin 13 IC3: +12.6 volts

Pin 1 IC3: +6.0 volts nominal, varies with C38

Pins 4, 8 IC4: +12.6 volts

Jct. R14, R13, C17: -3.5 volts +/- .5 volt

2. Nothing should be getting hot. IC2 runs somewhat warm but not as uncomfortable to hold your finger on. If you experienced some deviation from voltage checks but were not too far away, you may still be okay, but remember this deviation and mark it as suspect if any further problems are encountered. If the following results are successful and the IF amplifier works well, minor variations can be ignored. Any major variation should be investigated, however, because there is a problem. Check for parts placement, values, solder shorts, and poor joints. Make sure that your test equipment is set up properly.
3. Set R18, R24, and R34 at center of rotation range.
4. When steps 1 to 3 are done, disconnect the DC voltage supply and connect a 75-ohm coax cable to the video output (negative lead of C42 to center conductor) and ground (shield braid). Terminate the end of the cable in a connector suitable for your TV or monitor. This is generally an RCA-type connector. If a TV with a video input is used, set the TV to the monitor mode. Connect the audio output (negative lead C41 to center conductor, shield to ground) to the monitor audio input. An external audio amplifier (stereo amp, etc.) can be used if your monitor has no audio capability. Use a line-level input. For the IF66, set the VCR or other source for channel 3 or 4 output, whichever is unused in your area. For the IF44, set the tuner or signal generator so a good 44-MHz IF signal is present at the input of the IF44. Connect a cable of 75 ohms impedance from the VCR output (generally an F-type connector), or the test tuner as applicable, to the IF input terminals (center conductor to C1, shield to ground). Note that all cables must have the shield braid grounded at both ends. Never break the shield connection as is sometimes done in audio work because severe video degradation and interference will result. In order to avoid some potential problems and possible short circuits, it is a good idea to keep the bottom of the PC board at least 1/2 inch above any kind of material which may detune the circuitry. Note that in addition to metals, wood, plastics, and other dielectric materials may also cause detuning. A set of four

- 1/2-inch or 3/4-inch standoffs installed in the four corner holes is ideal for this purpose. Use only a nonmetallic tuning tool for all adjustments.
5. Temporarily connect a clip lead between TP1 (free end of R21) and ground. If you are building the IF66, place a tape in the VCR and start it in the play mode. For the IF44, activate the IF signal source or TV tuner you had previously rigged up. Having at first confirmed that the monitor and VCR (or the TV tuner) are working, observe the monitor. Then, reconnect the DC power supply (13.2-volt DC) to the board. You should see at least some noise or indication of circuit activity appear when the DC supply is connected. Some audio activity should be heard, if only an increase in noise. If not, check all connections. Ground TP1 (free end of R21) with a clip lead. For the IF44, skip step 6 and proceed to step 7.
 6. Couple a frequency counter via a two- or three-turn loop to oscillator coil L3. Rotate C9 to obtain a reading of 107 MHz (IF = CH3) or 113 MHz if channel 4 input is desired. Readings within ± 200 kHz of these frequencies are fine initially. The reading should be steady. Consider any wildly jumping or way off reading to be invalid. An FM receiver tuned to a quiet spot near 106 MHz can be used if no counter is available or if a reliable counter reading cannot be obtained. Listen for the LO signal as C9 is rotated. It will sound like a sudden quieting of background noise as C9 is tuned through the receiver frequency. TP1 must be grounded for this adjustment.
 7. Connect the negative lead of a VOM or DVM to ground. Connect the positive lead to pin 18 of IC2. Adjust the slug of L6 until a video image appears on the monitor. When a picture is received, set L6 for 4.5 volts reading at pin 1. Next, connect the positive lead of the meter to TP4 (wiper of R24). Adjust for a reading of about 4.5–5 volts. Leave L5 in the preset position for now. Adjust R34 for optimum picture quality on the monitor. Next, remove the clip lead from TP1 (free end R21). The picture may become garbled (IF66 only), but this is acceptable. Connect the positive lead of the meter to TP2 (jct. R1, R6, C14) and adjust the slug in L4 to bring back the picture on the monitor (IF66 only). No effect will be noted on the IF44 model. For the IF66, adjust L4 for best picture, which should occur at around a +3-volt reading. For the IF44, adjust also for +3.5 volts, although no effect will be noted on the picture. This adjustment will be somewhat “sharp.” With the IF66, retouch C9 so the best picture is obtained at a reading of 3–3.5 volts at TP2. This is the AFT adjustment.
 8. Adjust C38 for the clearest received audio. If you run out of adjustment range and C38 is fully meshed or unmeshed at the best audio setting, change C39 to 82 pf or 56 pf, respectively. This step will likely be unnecessary in most cases. Before doing this, check that the value of C33 is correct (3.3 pf, not 33 pf), L7 has continuity, and C40 is properly installed. If still no audio is generated, check that FL1 and FL2 are not accidentally interchanged and that IC3 and associated components are correctly installed.
 9. Try adjusting L5 for maximum RF voltage at pin 25 of IC2. If this is not possible because of a lack of test equipment, experiment for the best-appearing picture. This adjustment is somewhat broad and if it seems to have little effect, simply return the slug to the initial preset default position in step 3 (backed out 2.5 turns from flush with top). In tests on several prototypes, this seemed to be the optimum setting.
 10. Adjust L1 and L2 for a frequency response within 2 dB over the range of 60–72 MHz (IF66) or 40–47 MHz (IF44). If no suitable test equipment is

available, try adjusting the slugs for best picture. Do not exceed ± 2 turns in either direction from the initial flush settings. If little or no improvement can be seen, just return the slugs to the initial default settings.

11. Vary the supply voltage from 11.5–14.4 volts. *Do not exceed* 14.4 volts. The IF should work over this range. If not, recheck all settings and readjust as needed. Sometimes L6 has to be reset slightly.
12. (IF66 only) If channel 2 operation is desired, add a turn to L1, L2, and L3. Conversely, if channel 5 or 6 operation is desired, remove one or two turns from L1, L2, and L3, respectively. In these cases, LO frequencies are 101 MHz for channel 2, 119 MHz for channel 5, and 129 MHz for channel L4, L5, and L6 are the same, and except for the different LO frequency, alignment is the same.

The IF strip can be mounted in a suitable metal or plastic case with input, output, and power connectors of the builder's choice. A metal box is preferred because it provides shielding and reduces noise pickup. We recommend F or BNC for the input, RCA for the outputs (both video and audio), and some sort of polarized DC connector for the power connector, such as a 2.5-mm plug and jack, unless you have other specific needs. Because the circuitry consumes around 2–3 watts of DC power, it runs somewhat warm, so some provision should be made for ventilation if the circuit is to be packaged in a very small space.

IF70 FM TV

The IF70 requires very little setup and should work well enough even with no alignment so a video image can be seen and some audio can be heard. A DVM and a source of 70-MHz signal is needed. A CW signal can be used. If video modulation is desired, FM video is needed. Conventional AM video as derived from modulators or VCRs will not work. An unmodulated (CW) carrier is adequate and will get you close enough so that when an actual FM video is available, a slight readjustment of L1 and C29 is all that is needed.

With the circuit board powered up, check for the following voltages:

Pins 4 of IC3, IC4: -5 volts ± 0.5 volt

Pins 11, 14 of IC2: -5 volts ± 0.5 volt

Pin 11 IC1: -5 volts ± 0.5 volt

Pins 7 of IC3, IC4: $+5$ volts ± 0.5 volt

Pins 2, 3, and 6 IC3, IC4: 0.0 volt ± 0.3 volt

Pin 13 IC5: $+8$ volts ± 0.6 volt

Pin 1 IC5: $+2$ to $+6$ volts, varies with C29 setting

Emitter Q2: $+0.7$ to $+1.0$ volt

Collector Q1: 1.3 to $+2.0$ volts

Collector Q2: 8 volts ± 0.6 volt

Emitter Q3: 0.3 to $+1.0$ volt

Emitter Q4: 0.0 volt ± 0.3 volt

Pins 1, 16 IC1 and IC2: -1.0 volt ± 0.2 volt

Pins 7, 10 IC1 and IC2: -1.8 volts ± 0.3 volt

Pin 14 IC1 (RSSI TP1): -4.5 volts ± 0.5 volt (zero signal input)

Pins 4, 5 IC2: -1.8 volts $\pm .3$ volt, depends on input signal

Assuming that all of these voltages reasonably check out, connect a signal source of 70.0 MHz ± 200 kHz to the IF input, between C1 and ground. Adjust the level to 2–10 mV. Now, while observing the voltage produced between pins 4 and 5 of IC2 (usually between +1 and -1 volt), adjust L1 for a null (0 volt). Next, with no signal into the input, adjust C29 so the voltage from pin 1 IC5 to ground is halfway between maximum and minimum that can be observed while adjusting C29. Alternatively, leave C29 set so that the plates are at 1/4 mesh. This completes initial alignment. (Refer to PC layouts Figures 15-31 and 15-32.)

When the IF70 is installed in a system, adjust C29 for best audio and L1 for best video as determined on a monitor or oscilloscope. The initial default alignment is found to be fairly close to optimum in many cases.

Interfacing Considerations

Although the IF44 and IF66 IF strips provide signals suitable for most standard monitors and other devices needing 1-volt negative sync 75-ohm video and line-level hi-Z audio (0.5 volt peak-to-peak into 5K-ohm loads, typically), for best performance the input signal levels should be kept within certain limits to maximize dynamic range and s/n ratio. Various downconverters and tuners can be used as front ends, but the best results will be obtained with those that have 30–40 dB power gain and reverse AGC capability. Units with dual-gate MOSFET RF stages are easiest to interface with these IF strips. Gain reductions of 30 dB or more in the RF stages may be needed under full AGC conditions.

Note that use of the IF44 requires moving the LO injection frequency used in an accompanying downconverter from *below* the received TV signal to a frequency nominally 45.75 MHz *higher* than the received video frequency. The IF66 is

Figure 15-31
IF70 PC Board Art-
work Solder Side

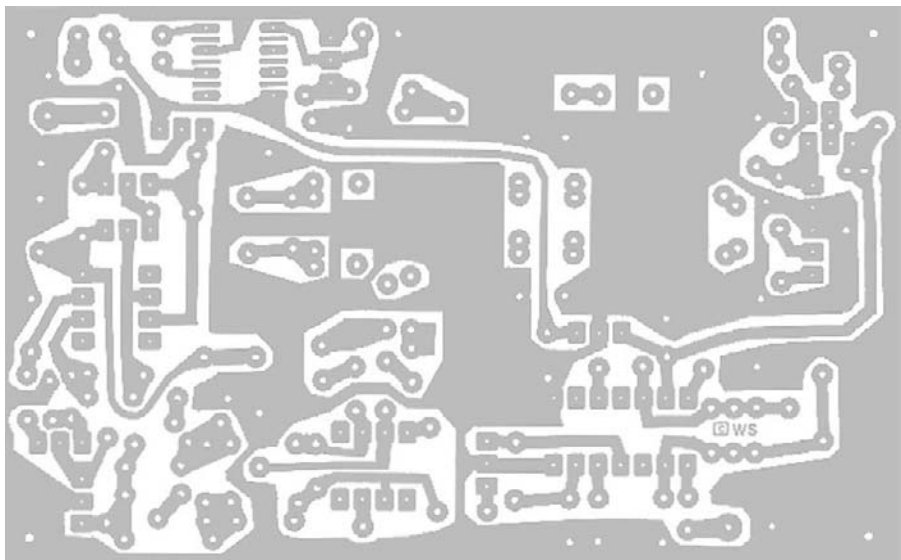

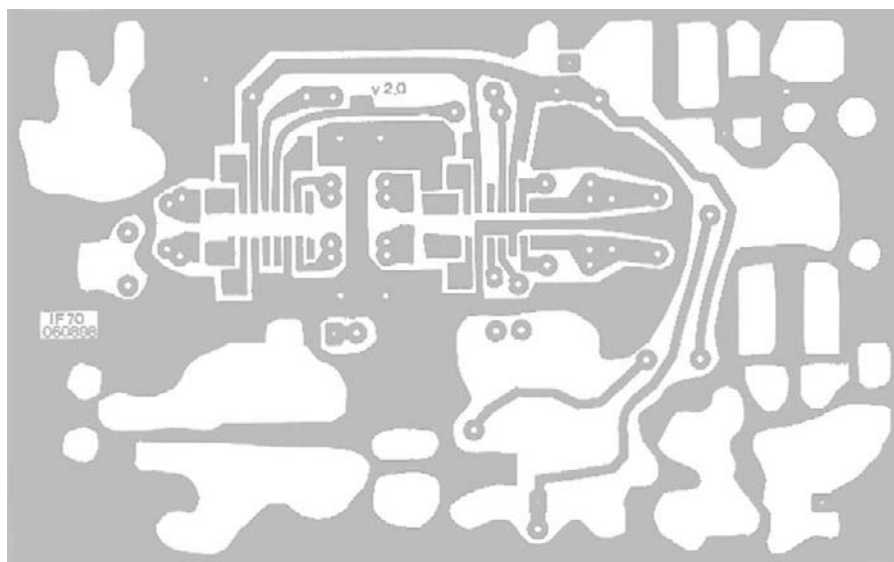

Figure 15-32
IF70 PC Board Art-
work Component
Side

designed to handle channel 3 to 4 existing IF signals that have already been down-converted to permit proper reception on a standard TV receiver. The IF66 has a high-side LO circuit and acts like a standard TV RF receiver system. But the IF44 is a straight amplifier with no LO circuit, and therefore the downconverter must have its LO injection on the *high* side of the received signal to retain correct video and sound subcarrier relationships in the IF amplifier system. The standard NTSC IF frequencies are 45.75 MHz for video and 41.25 MHz for audio (sound) subcarrier. This is because RF tuners used in commercial TV receivers must use high-side injection of the LO signal to allow practical LO circuitry for reception of the VHF channels in the 54–72 MHz range (channels 2, 3, and 4). Therefore, change of downconverter LO frequency is necessary; however, this seeming inconvenience allows a single conversion receiver scheme to be used without the possible spurious responses that can occur with the extra conversion step used in the IF66.

The IF70 does not have this problem because LO frequency affects only video polarity, which is easily reversible via onboard jumper settings. The channel 3-4 (IF66) scheme allows use of a downconverter that is intended to be used with a TV receiver, whereas the IF44 approach requires a dedicated downconverter that is not directly usable on a stand-alone basis. The advantage here is possibly better RF performance using less circuitry. In any superheterodyne receiver, the fewer the conversions the better from a spurious response and intermodulation standpoint. Mixers are the weak link. Alignment is also simplified because only one LO is used, and overall circuit cost and complexity is reduced. If a dedicated video receiver setup is needed, the downconverter with high-side LO and IF44 would be a technically advantageous approach.

The use of AGC on the RF amplifier stage in the downconverter is strongly advised. Although not needed for FM, it is almost mandatory for AM operation. IF strip input signals up to 10 mV or so can be handled, but with 30 dB downconverter gain, input signals of 300 microvolts are all that may be tolerated before IF overload occurs without AGC applied to the downconverter. Therefore, for best results, it is recommended that the AGC output from TP6 in the IF44 and IF66 be connected via a

jumper wire to the gain control input of the RF amplifier stage in the downconverter. Also, a capacitor of 10–100 microfarads (mfd) from this point to ground, to provide filtering and a time constant, is necessary. Failure to provide this capacitor results in picture breakup on strong signals, with horizontal “pie crusting,” horizontal lines, and an otherwise noisy, poor-quality picture. These capacitor values provide a 0.1–1 second AGC time constant, and although we would recommend 47 mfd, it is advisable to experiment with other values between 10–200 mfd for best results in a particular situation.

The capacitor should ideally be nonpolar because AGC voltage may vary from +1 volt at maximum gain to –3 volts at full AGC. In practice, most good-quality aluminum electrolytics of the ordinary polarized type function normally with up to somewhat more than 1-volt reverse voltage, with no harm done. Therefore, you can likely get away with using an ordinary polarized type if you make sure that the *positive* lead is connected to ground. If you are uncomfortable with this approach, you can use two back-to-back electrolytics, a single nonpolar unit, or even a Mylar-type capacitor for small (10 uf) values. Refer to the schematic of the particular downconverter for detailed information. Downconverters from various manufacturers may need modifications that depend on circuitry. This must be left to the experimenter.

R18 in the IF44 and IF66 should be adjusted such that the AGC voltage starts to fall from +1 volt toward negative levels when a signal of about 5–10 mV is present at the IF input. This means that the downconverter runs full gain at up to 100–300 microvolts received signal levels. The noise level, assuming a 4-MHz bandwidth and 3 dB noise figure (NF) for the downconverter RF stage, is around –105 dBm (or about 1.3 microvolts) in a 50-ohm system. The s/n ratio of the received picture is at least 38 dB before AGC action reduces downconverter gain. Some perceptible noise (snow) is still present at these levels; however, if the AGC reduces the downconverter gain too soon, the received picture will have less than optimum s/n ratio on strong signals. In this case, snow is still evident on even strong signals. Experiment with the setting of R18 for best results. The best setting gives optimum results on a relatively strong signal.

Complete kits of parts to build all of the projects in this chapter consisting of drilled and etched circuit boards, complete documentation and layouts, and all parts that mount on the boards, as well as accessories such as cases, hardware, and antennas, are available from the following supplier:

North Country Radio
P.O. Box 53, Wykagyl Station
New Rochelle, NY 10804-0053
E-mail: support@northcountryradio.com
Website: www.northcountryradio.com

The choice of parts and printed circuit board layout is critical for the projects described in this chapter, and the kits are especially recommended to ensure success with these projects.

16. Low-Power Narrowband FM Audio Transmitters

Although many modern narrowband FM (NBFM) transmitters use a phase locked loop (PLL) system to directly generate RF output at the transmitter output frequency, the use of traditional crystal oscillator and multiplier chain still has some merits. Among these are possibly better phase noise characteristics, freedom from microphonics, good stability, simple circuitry, and relative freedom from the danger of obsolescence caused by manufacturer discontinuance of the LSI IC. This IC is the heart of the PLL circuit and generally is a sole source component. Many service technicians are more comfortable with the traditional oscillator-multiplier approach, which has been used for many years. The use of generic parts makes servicing easier, especially in areas where parts procurement is difficult. On the other hand, the more modern approach using a PLL is simpler, easier to tune up, and more versatile, and the better choice for current product design (as long as the LSI IC continues to be available). An example of each approach is shown.

The first transmitter to be described is a VHF NBFM transmitter that employs the traditional oscillator-multiplier approach. The transmitter is intended for use on the 2-meter (144–148 MHz) amateur band. This transmitter uses a crystal oscillator that employs a varactor diode and inductor in series with the crystal. A fundamental mode crystal operating in the 18-MHz range—one eighth the output frequency—is used. The voltage on the varactor is modulated with the audio to be transmitted. This is effectively a narrowband voltage-controlled crystal oscillator (VCXO). The output circuit of the crystal oscillator contains a double-tuned circuit to pass the second harmonic of the crystal at 36.6 MHz. The output of the crystal oscillator feeds a frequency doubler and is multiplied by two, producing output at 73.3 MHz. This is followed by another doubler that produces the final output frequency at 146.52 MHz, and then a power amplifier stage delivering 0.25 watts to a 50-ohm load. This is adequate for short- and medium-range transmission up to 1–2 miles with a simple “rubber ducky” or quarter-wave whip antenna. It is possible to extend this range to several miles by working through a repeater, as is the usual practice in 2-meter (146-MHz) amateur radio work. A crystal cut for 18.315 MHz is used, and this gives output on 146.520 MHz, the commonly used frequency for simplex work. This circuit could be operated anywhere between 130–180 MHz with appropriate component substitutions. A fundamental cut crystal is much better regarding its ability to be used in a VCXO than is a third overtone crystal, with better modulation characteristics, because the effective Q of a fundamental crystal is often somewhat lower than a third overtone crystal and less tricky to “pull” in operating frequency, exactly what we want in a VCXO. The extra multiplier stage acts as a buffer, which may be needed with the third overtone oscillator approach.

Referring to the schematic of the RF section shown in Figure 16-1, crystal oscillator Q1 is a Colpitts type with the crystal acting as the inductor, C1 and C2 the

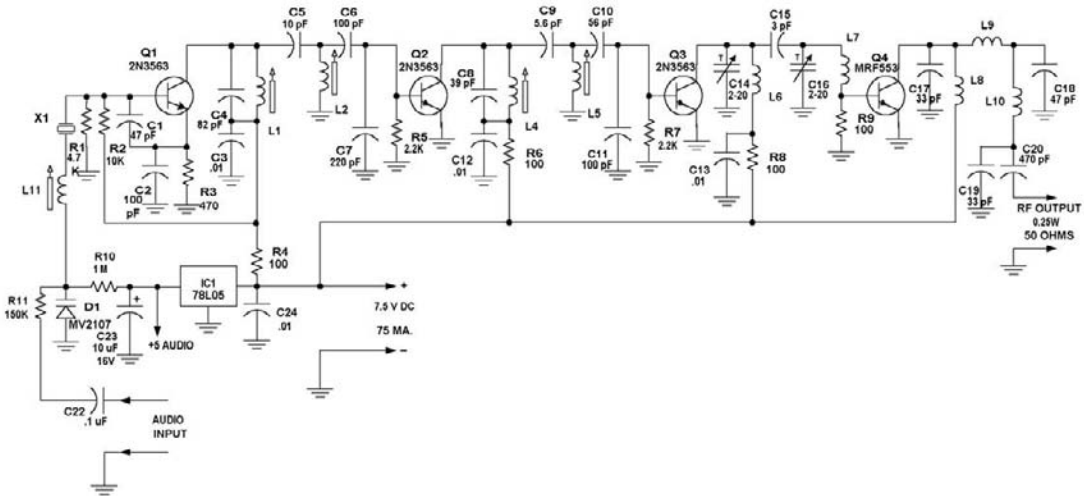

Figure 16-1
Schematic of a 0.25 to 0.5 W Narrowband FM VHF Transmitter (144-148 MHz)

feedback capacitors, and L11 and the varactor diode as an auxiliary LC network in series with the crystal. L11 is used to set the transmitter on the exact frequency and has a range of a few kilohertz. A fundamental cut crystal cut for 20 pF capacitance parallel resonant should be used. R1, R2, and R3 are bias resistors for Q1. In the collector circuit of Q1 is a double-tuned circuit tuned to the second harmonic of the crystal, L1, C4, C5, L2, C6, and C7 serving as a 36-MHz bandpass filter. R4 and C3 are decoupling and bypass components for the oscillator stage. The second harmonic energy is fed to the base of doubler Q2. R5 is a bias resistor. The collector circuit of Q2 consists of another double-tuned circuit nominally tuned to 73 MHz. C8, L4, C9, L5, C10, and C11 make up this network. R6 and C12 are decoupling and bypass components for the first doubler stage. Q3 is another doubler similar to the Q2 stage except for component values. Trimmers C14, C16, coupling capacitor C15, and L6 and L7 are tuned to 146 MHz, with R8 and C13 serving as decoupling and bypass components. The next stage Q4 is a power amplifier stage that delivers about 0.25–0.3 watt output to a 50-ohm load with a 7.5-volt supply.

With a 12-volt supply, as much as 1 watt can be obtained. L8, C17, L9, C18, L10, and C19 are used for matching the impedance of the power output stage to a 50-ohm load and to reduce harmonic components to less than 40 dBc. This stage runs at 50–60 percent efficiency, and the oscillator-multiplier chain Q1-Q2-Q3 draws about 30 mA at 7.5 volts. The entire RF section draws about 100 mA at 7.5 volts. IC1 is used to derive a regulated 5-volt bias for the varactor diode and the audio amplifier stage to be discussed later (see Figure 16-2). R10 and R11 feed bias to the varactor diode, and audio is fed through R11 and coupling capacitor C21. The audio voltage modulates the bias on the varactor diode, varying the crystal oscillator frequency, and therefore producing an FM signal as the transmitter output. Deviation is set to 5 kHz by means of the audio level applied to the varactor diode.

This transmitter is typical of small “traditional technology” VHF FM transmitters. More power is obtained simply by using the transmitter output to drive a power amplifier delivering the desired power. Because the output of an FM transmitter is

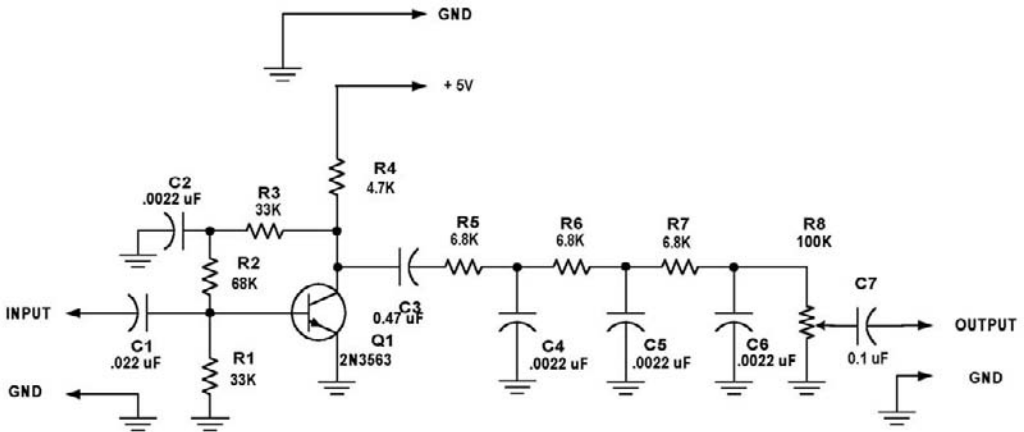

Figure 16-2
Simple Audio Amplifier for Narrowband FM Transmitters

constant in amplitude, a simple class C power amplifier can be used because linearity is not required. Tuneup is simple, with all adjustments made for maximum drive to the next stage (the collector current of a stage can be monitored while its input network is adjusted), and finally all adjustments peaked for maximum output into a 50-ohm load. Although it is straightforward and simple, it uses several discrete components, which means more manufacturing costs. The increased number of stages needed to reach the higher frequencies (450 and 900 MHz), as well as the complexity of tuneup, makes a simpler approach more attractive in some cases. A PLL system can eliminate the need for the oscillator and multiplier chain in many cases. The next circuit discussed illustrates this point.

It is possible to use a single IC chip to perform the functions of transmitter low-level signal generation. The Motorola MC13176D IC is a 16-pin surface-mount device that uses the PLL approach to generate a signal in the UHF band. We discuss a flea power (1 mW) transmitter that produces an NBFM audio signal on the frequency of 446 MHz. This happens to be the national simplex (direct communication, no repeater being used) frequency for FM two-way amateur communications in the 70-cm band. Although 1 mW may be dismissed as useless other than as a demonstration, this is not necessarily true. First, antennas are small at this frequency, with a full quarter-wave whip being a little more than 6 inches long. Radiation efficiency is high, and the ease of providing an adequate ground plane (the transmitter case and batteries in many instances being adequate) allows an efficient antenna system compared to lower VHF frequencies. A good portion of 1 mile can be covered with power levels of a few milliwatts because the bandwidth used (13 kHz) allows a sensitive receiver to be used (typically 0.15–0.2 microvolt for 20 dB quieting for modern designs). Therefore, a useful short-range transmitter can be constructed from a single IC chip, and the whole transmitter powered with a 3-volt supply, two AA or AAA cells being adequate because current drain is only about 30 mA. If more power is desired, the output of 1–2 mW can be fed into another RF amplifier stage, but we did not pursue this approach because the power output is adequate for short-range use. This circuit can be powered by a supply of 1.8–5 volts; however, remember that the

varactor diode controls the transmitter frequency and its bias should be constant. A regulator can be used to derive a constant bias if a varying supply is used to power the transmitter. The bias can be 2–4 volts, as needed.

The MC13176D unfortunately is not available in standard DIP packages, only in rather experimenter-unfriendly surface mount. It is a fact of life that many of the newer chips that offer much to the experimenter turn out to be almost unusable because of the mechanical difficulty in working with them with ordinary hand tools. These devices are designed for automated assembly and large-volume use in compact equipment. This type of equipment (cell phones, computer-related items, etc.) often has a short life cycle (1–3 years) because of rapid technical obsolescence, must be low in cost, and is generally not designed to be repaired down to the component level. Pin spacings of 0.050 or 0.030 used in packaging these chips, with 24 pins or more, can be difficult to work with by the typical experimenter; however, the 8-pin SO8 and the 16-pin SO16 are not as bad as they may appear. Several easily available 8- and 16-pin devices are useful for RF applications. A study of the pin layouts of these devices and a little thought about circuit board layout often results in a layout that can be feasible to build with hand tools and a little care. A few of the pins are often grounds and supply pins, and only a few peripheral components are needed.

Chip resistors and capacitors of 60-by-120-millimeter size are fairly easy to work with. Also, 1/10 watt resistors and small ceramic discs can be used. There is often no real need to use an ultra-compact layout anyway. The small packages and short leads that are obtainable with surface mount permit good UHF performance with fewer of the circuit difficulties often experienced with circuits constructed from larger through-hole components. So, the experimenter should not turn away from using these devices because useful items can often be constructed. Examining the MC13176 data sheet (Figure 16-3) reveals that it is basically a PLL system with a VCO (in this case, actually a current-controlled oscillator, or CCO), divider (fixed at $\div 32$) reference oscillator, and phase detector. The reference oscillator is generally used with an external crystal, and the PLL output frequency is therefore 32 times the crystal frequency. This would be the same as that obtained using five doubler stages in a conventional multiplier chain. The PLL can be operated as high as 950 MHz. A balanced RF output is provided, with capability for AM or FM, or pulse modulation. With a 3-volt supply, 1–2 mW output into a 50-ohm load is possible. Although it is possible to introduce audio into the PLL directly, NBFM of 5-kHz deviation is easily done with a varactor diode in series with the crystal. Because the output frequency is the crystal frequency times 32, only 150-Hz deviation is needed. With the required 13.9375-MHz fundamental cut crystal needed for 446.000-MHz output, this is easy to get, with good modulation linearity.

Examining the circuit of the transmitter (Figure 16-4), some rearrangement from the recommended (data sheet) circuit was made. In order to be more compatible with other circuits in this book, a negative ground supply is used. Good bypassing of the positive rail is obtained by chip capacitors C2, C3, C5, C9, and tantalum capacitor C4. Note that pins 2, 3, 5, 10, and 15 are grounded. Instead of expensive, difficult-to-find manufactured coils and chokes (for the home hobbyist without OEM accounts at several distributors), coils were wound from magnet wire. A simple twisted-wire balun was used at the output instead of the short length of rigid coaxial cable specified. This worked just as well, and the hobbyist can make it. L4 is a 1.5–3.5 (or more) microhenry slug-tuned coil, and materials for this can be found in a junked TV or CB radio of the 1970s–1980s vintage. It consists of 19 turns of #32 gauge wire close-wound on a 1/4-inch-diameter slug tuned form. Moving the slug in and out



Figure 16-3
Data Sheet of
Motorola
MC13176 UHF FM/
AM Transmitter
Chip

The MC13176 is a one chip FM/AM transmitter subsystem designed for AM/FM communication systems. It include a Colpitts crystal reference oscillator, UHF oscillator, +32 prescaler and phase detector forming a versatile PLL system. Targeted applications are in the 260 to 470 MHz band and the 902 to 928 MHz band covered by FCC Title 47; Part 15. Other applications include local oscillator sources in UHF and 900 MHz receivers, UHF and 900 MHz video transmitters, RF Local Area Networks (LANs), and high frequency clock drivers. The MC13176 offers the following features:

- UHF Current Controlled Oscillator
- Uses Easily Available 3rd Overtone or Fundamental Crystals for Reference
- Fewer External Parts Required
- Low Operating Supply Voltage (1.8 to 5.0 Vdc)
- Low Supply Drain Currents
- Power Output Adjustable (Up to 10 dBm)
- Differential Output for Loop Antenna or Balun Transformer Networks
- Power Down Feature
- ASK Modulated by Switching Output On and Off
- $f_o = 32 \times f_{ref}$

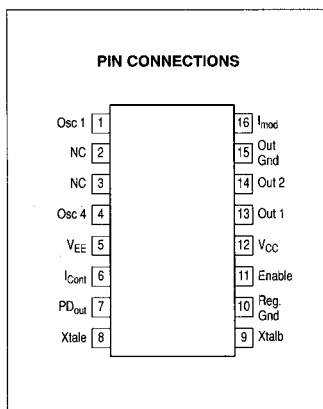
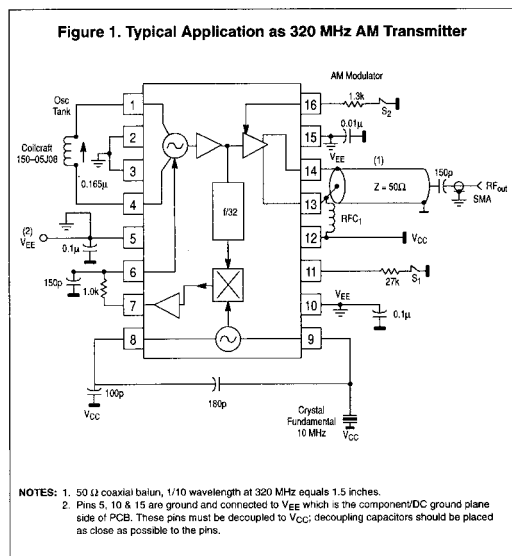
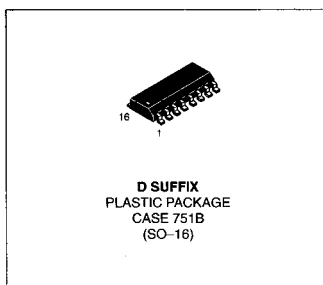

ORDERING INFORMATION

Device	Operating Temperature Range	Package
MC13176D	T _A = -40 to 85°C	SO-16

MOTOROLA WIRELESS SEMICONDUCTOR
SOLUTIONS - RF AND IF DEVICE DATA

MC13176
3.2-257

varies the inductance. If preferred, a commercially made coil of suitable inductance can be used. The circuit works as follows:

Crystal X1, a 13.9375-MHz fundamental cut crystal, is used in conjunction with feedback capacitors C6 and C7 (47 pf chips) to act as an oscillator. Inductor L4 and varactor diode D1 (an MV2107, 22 pf at 4 volts bias) appear as a reactance network in series with the crystal. R3 acts as an isolation resistor and with R4, returns the varactor to ground. The cathode of the varactor is returned to the 3-volt supply and is reverse biased by this amount. Audio is coupled via C8 to R4 and appears across R4,

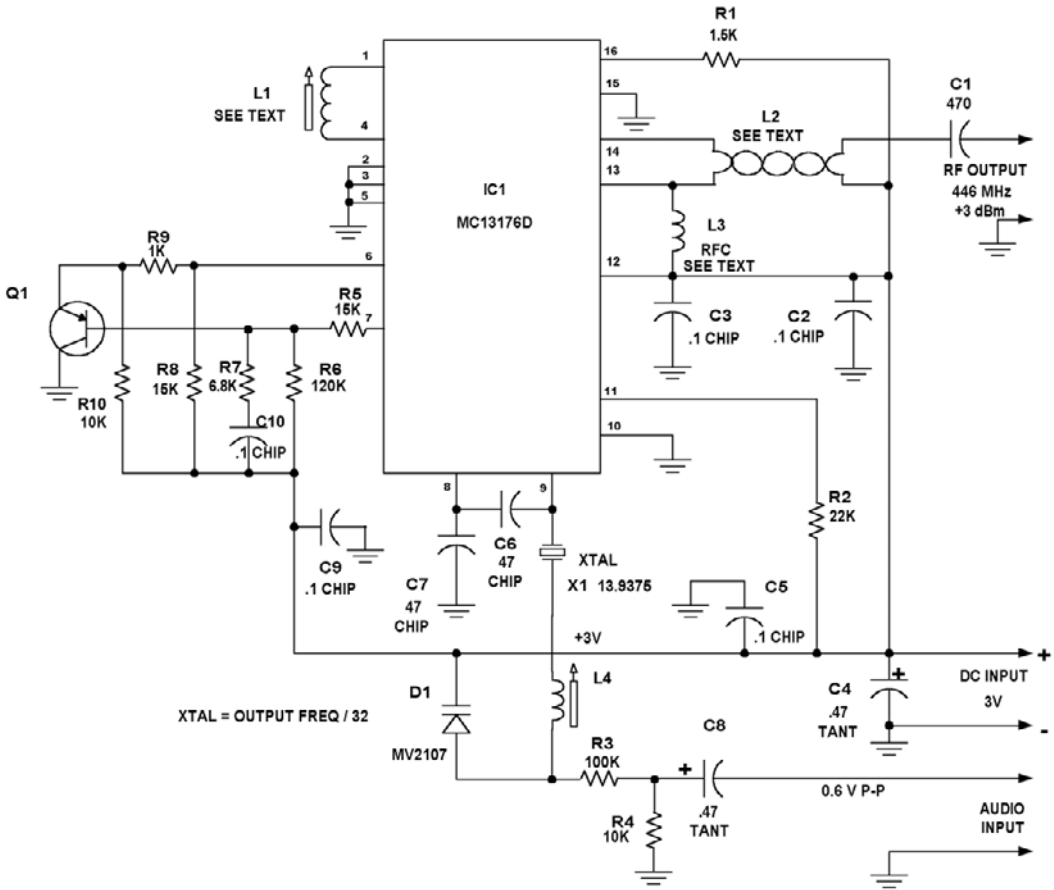

Figure 16-4
Schematic for a 446 MHz Amateur FM Transmitter

and the audio voltage is effectively superimposed on the varactor bias. This causes the capacitance to vary at an audio rate, effectively modulating the reactance and therefore the oscillator frequency. Slug-tuned coil L4 is used to adjust the crystal frequency, so the output frequency is exactly 446.000 MHz. About 0.6 volts peak-to-peak is required for the full 5-kHz deviation. This audio is obtained from an audio amplifier and is preferably limited to this level by using a clipper and lowpass filter to remove speech components above 3000 Hz. Also, suitable preemphasis should be used. This is usually a simple 6dB per octave rising response from 300–3000 Hz and improves the signal-to-noise ratio at the receiver. The audio amplifier, limiter, and clipper are straightforward and are not discussed here. A suitable circuit is shown in Figure 16-2, which is discussed later. Limiting is obtained by driving the amplifier into saturation and cutoff because it operates from a 5-volt supply.

L1 is the current-controlled oscillator (CCO) coil. It is seven turns of #22 bare wire wound in the threads of an 8-32 screw as a mandrel. The screw is withdrawn after winding the coil, leaving an airwound solenoidal coil. This coil is slightly high in inductance, and in the circuit will have to have its turns spread somewhat to achieve the correct CCO frequency (446 MHz). The rest of the CCO components are

inside the chip. A current from current amplifier Q1 controls the CCO. Loop filter components that determine loop characteristics are R5, R7, and C10. The output of the internal phase detector appears at pin 7. R6, R8, R9, and R10 are biasing resistors for amplifier Q1. The current into pin 6 controls the VCO frequency; it can be either a positive or a negative current. The loop amplifier Q1 supplements the 50-microampere current available from the internal source in the chip and provides a 100-microampere boost, increasing the available current swing and therefore the hold in range of the loop. RF output appears at the differential output pins 13 and 14 and is converted to single-ended output by L2. L2 is 2 inches of a twisted pair of #32 magnet wire and acts as a balun transformer. This is not critical, and two wires twisted about 10 twists per inch were used. C1 serves as a DC blocking capacitor. RF choke L3 is nine turns of #24 magnet wire wound into an aircore solenoidal coil using an 8-32 threaded screw as a mandrel; it is not critical.

The current into pin 16 controls the RF output and is obtained via R1. About 2 mA is needed for maximum output. R1 could be made variable (use a 5K or 10K potentiometer) if you want to vary the output power. Pin 11 is a chip-enable pin and can be used as an on-off control. When pin 11 is open, the transmitter is powered down (off state).

This transmitter was breadboarded using a ready-made PC board from Motorola (see data sheet Figure 16-3), and a layout similar to that shown should be used. If you are experienced in RF work, you can modify the layout as needed, but be sure to follow the suggestions given in the data sheet regarding proper bypassing and grounding. It worked the first time, and good results were obtained. Spurious outputs were measured as -35 dB down with respect to the carrier, which is not too bad considering the simplicity of the circuit. These spurs were spaced approximately 14 MHz from the carrier frequency and are caused by reference frequency mixing with the CO frequency. Proper filtering using tuned circuits can reduce them.

Using a pocket scanner, the transmitter signal was picked up loud and clear over 1/4 mile from the laboratory. The transmitter breadboard was sitting on the lab bench, feeding a 6-inch whip antenna. A 400-Hz audio tone was used for modulation, and the transmitter was set for 5-kHz deviation. A 3-volt power supply was used, and supply current was 28 mA. This is not bad performance at all. This circuit should find application wherever a low-power UHF audio transmitter is needed, and it makes for an interesting experimenter project. Note that a ham license is needed to place this transmitter on the air legally using the 446-MHz frequency.

An audio amplifier is needed for these FM transmitters. It should provide some limiting of output so as not to produce excessive frequency deviation. In addition, frequency response should be a 6 dB/octave rise to 3000 Hz, then a falloff of 12 or 18 dB/octave to eliminate excessive high frequencies and components generated during audio limiting. Audio limiting may be done with a clipper circuit using diodes or by designing the audio amplifier to limit by using a low-supply voltage to limit output and making sure that the limiting is fairly symmetrical on positive and negative waveform excursions. A simple audio section suitable for use with these transmitters is shown in Figure 16-2. A single transistor Q1 is biased by R1, R2, R3, and R4. A 5-volt regulated supply is used, and the bias point for the transistor is selected for simultaneous positive and negative peak limiting. About 4 volts peak-to-peak swing is obtained, and the gain of the stage is approximately 12 times at 1000 Hz. This allows a microphone or audio source of about 0.1 volt rms to drive the amplifier to full output. Coupling capacitor C3 couples audio to RC network R5, C4, R6, C5, R7, and C6. This network provides filtering of undesired high frequencies above 3000 Hz.

Build Your Own Low-Power Transmitters: Projects for the Electronics Experimenter

The output of this network feeds a potentiometer R8, which is set so that the audio to the transmitter is sufficient to produce the required deviation (normally ± 5 kHz), with maximum audio input level to the amplifier.

In addition, data in tone form (AFSK) may be fed into the amplifier if data is to be transmitted. Bandwidth is about 3000 Hz, which should handle any data that can be sent over a telephone line.

17. Serial Data Transmit-Receive System for Remote Control

It is often desired to transmit control signals for various devices via radio, infrared, or a carrier-current system. Simple on-off controls that detect a carrier presence or an audio tone modulated on a carrier are fine for this purpose but are susceptible to noise and false triggering from stray signals that may have similar spectral characteristics to the desired signaling tone. Analog schemes using 567-type tone decoders are an example of this kind of control. A much better and more flexible approach is to transmit a digital word of some kind, generally an 8-bit or 16-bit serial data stream, and compare the data at the receiver with a preset code. While a digital scheme can suffer false triggering as well, the chance is much more remote than with an analog scheme because only certain format signals are accepted, and error-correcting techniques can be used. A simple example is the use of a parity bit or a checksum. In addition, the digital signal can be transmitted in the form of tone signals and at a specified bit rate (or baud rate if you prefer, but remember that bit rate and baud rate are *not* necessarily the same thing).

By the use of a microcontroller and a few peripheral components, an asynchronous system using one or two ASCII characters is easy to generate and detect. Dedicated chips are available for various purposes from companies such as Holtek and others, but by “rolling your own,” you can have flexibility, not be limited to what is available, make exactly what you want, gain some experience with microcontroller programming, and not the least of all, avoid being at the mercy of any one manufacturer and their discontinuance of the part you need. For a dedicated mass-production application in a limited-life product, you are better off using ready-made ICs, but as a hobbyist or experimenter who wishes to learn something, programming your own custom chips is the way to go.

We will discuss a simple system using the popular PIC16F84 microcontroller that takes in an 8-bit word from an input switch and converts it to serial data, which can be fed to a suitable transmitter (which can be RF, infrared, carrier current, etc.), and a decoder that takes the serial data and recovers it in parallel form, with eight output lines that are useful for controlling almost anything you may want, with proper interfacing. We do not go into the minute details of PIC microcontroller programming because that would take an entire book and is a separate subject in itself. Microchip has all the information on their company website, with data sheets on all their microcontrollers that describe the instruction set, programming techniques, and an assembler for the PIC microcontrollers—free for the downloading—with excellent technical support.

If you are not familiar with or capable of using microcontrollers in your projects, you are missing out on a useful and powerful tool of modern electronics. Microcontrollers can do remarkable things for you if you learn to program them, and they open the door to many new opportunities. The lack of some programming capability

on the part of the experimenter keeps you from using many modern techniques in your projects. An example is in frequency synthesis: many of the modern synthesizer chips must be serially programmed to be useful. A microcontroller can generate the necessary waveforms and simultaneously manage a keyboard and display, and give “intelligence” to your project. For example, see the MPX2000 FM stereo transmitter described in this book. It would not be feasible without a microcontroller.

Yes, writing software is different from handling a soldering iron, but you don’t have to be an expert. There are no wrong ways to program. It is possible to write many programs to do the same thing, and none are wrong if they work. As long as the program works and does what you want it to do, any approach you choose is fine. You learn programming not by being a genius and reading a book, but rather by making mistakes, writing code that doesn’t work, then figuring out where you “screwed up,” just the way you become proficient in mathematics or gardening. All your “i”s must be dotted and all your “t”s must be crossed. If there is one error, things will not work out as planned. You must be meticulous and accurate with your syntax because a computer and an assembler program cannot know what you “really mean.” Fortunately, most assemblers will point out your syntax errors, but they will not always tell you how to correct them, and the error messages can be cryptic. Also remember that as long as the syntax is correct, assemblers will assemble a program that has errors. They will not tell you, for example, that your microprocessor will light the wrong LEDs or wind up in an endless loop, locked up until the system is reset. Of course, a “better” written program might accomplish a given function or objective with fewer lines of code, but as long as your project code fits in the chip or the EPROM you are using, who really cares anyway? We discuss the software approach and the flowchart to show the basic principles and describe the circuitry. You can customize this system as you see fit, and doubtless no two individuals who build the system will have the same application. That is the beauty of using a software approach—you can change the whole “personality” of a system with the change of an IC chip or by reprogramming that chip, without using a soldering iron or changing components.

We first discuss asynchronous serial data transmission. This form of data transmission is quite old, being used for many years by teletype machines. These electromechanical devices used a form of transmission whereby a current in a transmission circuit or “loop” was turned off and on. The presence of current was called a *mark*, and the absence of current was called a *space*. This terminology is still in use today. The data was sent at a predetermined standard speed, and a long pulse was sent at the beginning (usually a mark) to act as a start pulse. Then eight shorter pulses were sent, then a stop pulse, which was usually a “space” to designate the end of the data. The receiver looked for the long mark pulse, and when one was sensed, valid data was assumed to be present, the following eight pulses were sampled at an agreed-upon rate, and the stop pulse was then looked for. If this was present, the received data was considered valid, and the space pulse was used as a signal to reset everything and begin looking for the next incoming data, or *byte*. The sum of the individual bits could also be determined, or the sum tested to see if odd or even, and this was checked against a separate *parity bit* or bits for agreement as a further check for validity. Because the receiver samples the incoming pulses at a predetermined rate, the incoming data has to be coming in at that predetermined rate; otherwise, the received data would be garbled.

The bit rate, or the baud rate (*not* always the same), is set at an agreed-to standard: 50, 60, and 110 baud rates were used with mechanical teletype, but with modern

computers serial data can be transmitted at much higher rates, many kilobauds using standard voice-grade telephone lines or audio bandwidth (up to 10 kHz) radio circuits. Common rates are 1200, 2400, 9600, 14,400, 28,800, and 33,600 baud, as used by modern computer modems on telephone lines. This is done with multilevel coding, where a bit has several different states, such as amplitude levels or other distinguishing characteristics. In this way, a single bit can contain many “levels” and can be made to represent a byte or two of information, so one bit may actually be representing 16 “bits” of digital data. But the bit rate, a measure of the shortest width pulse the system can handle, is determined by system bandwidth, and in a telephone voice line, is limited to 2400–3000 bits per second. For a 12-level scheme at 2400 bits per second, this is 2400×12 or 28,800 baud. For simple binary information having only two states, the baud rate and bit rate are the same (not true for multilevel schemes). It is common to use K for Kilobaud, so a 14,400 baud modem is called 14.4K, and a 56,000 is called 56K (almost universal on newer modems). In a dedicated control system, almost any rate within the capability of the microcontroller can be used, and for a single system, no standard baud rate is required either, although one of the standard rates might be recommended for the sake of future interfacing with other situations that may arise.

The chosen rate must be fast enough to allow sufficient speed of response. A 10-baud rate, for instance, which may need more than a second to send a complete 8-bit data word and start/stop pulses, would be useless when a 50-millisecond control response time is needed. The time it takes for the microcontroller to process the information must be considered; however, because of other considerations, such as weak-signal narrowband situations (for instance, in deep space probe communications), slow signaling speeds may be necessary because of system bandwidth constraints. For practical control applications in many mechanical devices, a few tenths of a second to several seconds may be needed to perform an operation such as positioning a rudder or platform or rotating a camera into position; baud rates on the order of 500–3000 baud are satisfactory because the control signal duration is a small fraction of the operating time.

The system to be discussed uses a PIC16F84-04 microcontroller as a transmitter to generate the serial waveform in response to eight control inputs (see Figure 17-1). The control inputs are ordinary digital lines numbered 0 to 7, each having a logic high or low state, so a total of 256 possible combinations can be obtained. The lines can be used as the application demands. The bits sent each represent the state of a particular line 0 to 7. A serial data word is generated, and the state of each line is sent to the receiver by either direct connection or as information modulated on a carrier of some sort, which may be RF, infrared, or acoustical. The receiver performs the reverse function, taking in the data waveform, recovering the information, and providing eight data line outputs that have the same states as the original inputs to the transmitter. The receiver can provide up to 256 possible combinations. The baud rate is set by a crystal connected to the microcontroller and software.

We used a common 3.58-MHz crystal because these are cheap and widely available, but any crystal up to 4 MHz may be used. The circuit shown uses an eight-position DIP switch as a data source and eight LEDs as a display at the receiver to demonstrate the operation of the system, but these same outputs may be fed to any suitable device that takes CMOS or TTL logic levels. The receiver circuit is similar to the transmitter, the main difference being the IO devices (LEDs or DIP switches) and software. Application details are left to the individual user because many applications are possible.

Build Your Own Low-Power Transmitters: Projects for the Electronics Experimenter

The system can be interfaced to a low-power VHF-UHF transmitter in several ways. One approach, which is simple, involves using the output to key an RF carrier on or off. A mark is represented by the presence of a carrier, a space the absence of a carrier, or vice versa. This simple approach works well for simple control applications in which noise immunity is not a problem, such as a UHF garage door opener system. The receiver can be a simple AM receiver because all it has to do is detect the presence or absence of pulses and produce an output suitable for interfacing to the controlled device. This system is commonly called *pulse modulation*. Another approach is to use the output to frequency modulate a transmitter. This is called *frequency shift keying* (FSK). An FM receiver is needed in this case, the data appearing directly at the output of the FM detector. Another common approach is to use the data to modulate a tone generator in the audio range. One tone frequency is used to designate a mark, and another a space. Tones of 1200 Hz and 2400 Hz are commonly used for this purposes. The resultant audio signal is then fed to a low-power transmitter, where an AM or FM RF carrier is generated. This is known as *audio frequency shift keying* (AFSK). There are also other digital modulation schemes, such as PSK, QAM, and so forth. Consult a modern text on digital communications for information on these methods.

A radio receiver produces noise output in the absence of a received control signal, so some means has to be provided to produce a definite state (mark or space) at the receiver data output terminals in the absence of any signal. Normally, a squelch circuit is used in the receiver, which disables the receiver output in the absence of a

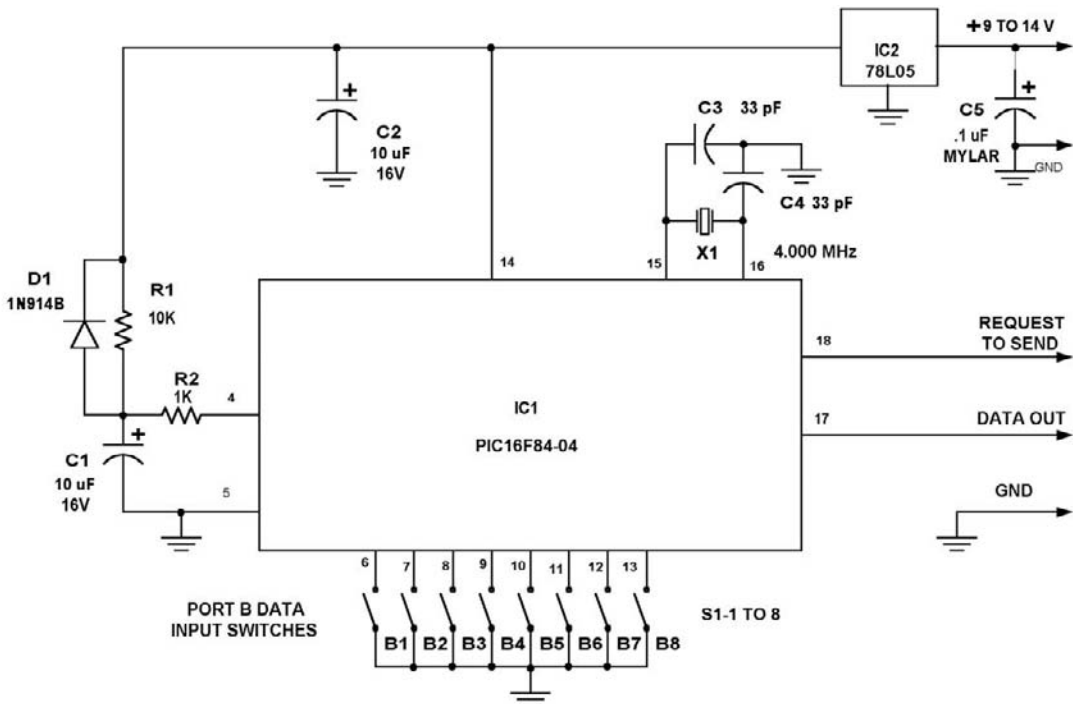

Figure 17-1
Schematic of the Serial Data Transmitter

received signal and sets the data output in a mark or space condition, as needed. Reception of a signal enables the receiver output and allows the received data to appear in the receiver output.

The operation of the transmitter is described (see Figure 17-1). Basically, a PIC16F84 microcontroller is used. It is set up in software to produce output at port A bit 0 (pin 17), which will be a logic high (mark) or low (space). Upon initialization and power up, output is set to logic high (mark). Port A bit 1 is used as a send pin, where the presence of a logical one starts the transmission of data from port A bit 0. Port B bits 0 to 7 are the data input pins; there are 256 possible combinations. Input data to each bit could come separately from a switch, a sensor output, a circuit, or anything else needing monitoring. Alternatively, all eight inputs could be used to take data from a bus, which may come from a computer, an analog-to-digital converter, or anything else. It really does not matter because we have eight independent input lines and 256 possible combinations. The object of the exercise is to transmit the data serially on receipt of a command from port A bit 0 to another device such as a low-power transmitter, and then receive them at a remote receiver. They are then converted back to their original format, so that the identical data appear at the remote receiver output, where it is used for monitoring, measurement, or control purposes.

Port A bit 1 is constantly being tested for a logic high state. If no high is present, the microcontroller is stuck in an endless loop, repeatedly testing this bit, and port A bit 0 stays high (mark). Upon receipt of a command to send (logic high on port A bit 1, which is pin 18), several things happen in sequence. An internal register CC is loaded with a count of 8 because we are transmitting eight bits. The internal timer is cleared to 0. Port A bit 0 is now cleared to a space for a time determined by a number loaded into the internal timer register. This sets the length of the start pulse and the baud rate. In our case, the timer is an 8-bit register, so it takes 256 counts to cycle it. The clock frequency for this chip equals the crystal frequency divided by 4, which turns out to be $3.579545 \text{ MHz} \div 4$, or slightly less than 900 kHz. An internal prescaler is programmed for divide by 4, and the output of this drives the timer. Therefore, the bit rate is $3.579545 \div (4 \times 4) \div 256$, or 873.9 bits per second.

By changing the crystal frequency or the prescaler and/or timer in software, any other bit rate may be produced. Because this project was intended to be a demonstration system, we used a commonly available crystal. Crystals are obtainable ready made that give standard bit rates (1200, 2400, 9600, etc.). After the timer times out, the start pulse is completed. Next, data from port B (pins 7 to 13) is transferred to the internal working register W and then to another register designated BB (direct register-to-register transfers are not supported in this chip). The carry bit is cleared, and register BB is rotated via software instructions one place to the left. This “kicks out” the most significant bit (bit 7) into the carry flag. Port A bit 0, the transmitter output, is cleared to 0. The carry flag is then tested and its status determined. If high, bit 0 of port A is immediately set high. If low, it is left cleared (logic zero).

Now, the state of the transmitter output is identical to the state of the most significant bit (MSB) of the input data at port B bit 7. Now there is nothing to do except wait for the next timer rollover. Upon rollover, the timer interrupt flag is reset, count register CC is decremented and tested for zero count, and the previous rotation and carry flag testing routine is repeated. This time, bit 6 appears on the output. The process is repeated six more times, outputting the states of bits 5, 4, 3, 2, 1, and finally 0; however, when 0 is reached, counter CC is 1, having been decremented eight times. On the next cycle, CC reaches 0. This is sensed, and the rotation routine no

longer occurs. Instead, a stop pulse must be generated. This is a logic high produced by setting port A bit 0 (pin 17). After another timer rollover has occurred, register BB is cleared, and count register CC is loaded with 10 decimal. The timer is used to decrement this counter, which produces a delay of 10 bits. After the register CC reaches 0, the loop returns to the start of the routine and tests to see if port A bit 1 is high. If it is, the routine starts again. If not, the routine waits in the test loop, repeatedly testing port A bit 1 for a logic high until a high is detected, whereby the cycle repeats.

The transmitter produces a stream of data pulses, repeatedly a serial version of the data at port B, as long as pin 18 is held high. When pin 18 goes low, the data stops after the completion of the current cycle, and port A pin 17 going to a constant logic high. This is the idle state. The schematic of the transmitter is shown in Figure 17-1. It operates from a standard 5-volt supply and easily interfaces with TTL or CMOS. As can be seen, relatively few parts are required, and the circuit can easily be adapted to a wide range of applications. The 12-position DIP switch is used to input data, and only eight positions are used in this application.

The receiver (see Figure 17-2) operates similarly to the transmitter, practically in reverse. The receiver takes in a serial data stream from the radio or other input device. It must be standard TTL or CMOS levels (5-volt logic) with mark high, space low. In addition, the bit rate of the receiver must match that of the transmitter because we are using asynchronous transmission. Some error can be tolerated, but it

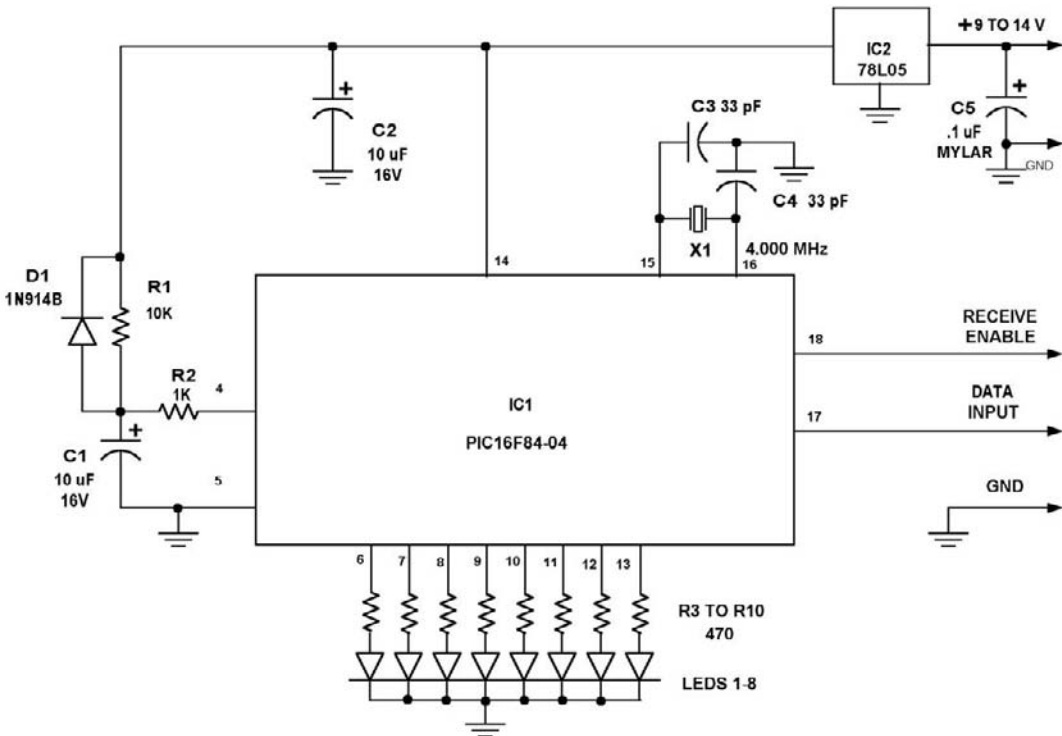

Figure 17-2
Schematic of the Serial Data Receiver

is best that they match. As in the transmitter, we are using a 3.579545-MHz crystal and an internal prescale of 4. Port A this time is used as the receiver input, with port B set up as the data output. Port B retains whatever data was last received. These things are all determined in software during the initialization routine on power up and can be changed by means of software changes as required.

Port A bit 1 is used as a receive enable and is set up as active high. The receiver ignores any received data if port A bit 1 is low. Port A bit 0 is used as the data input pin. The eight bits of port B bits 0 to 7 are used as data outputs. Operation is as follows: port A bit 1 is first tested for a high. The microcontroller is held in an endless loop until this bit is set. If this bit is high, the data input is tested for a space, indicating a possible start pulse. If a low is detected (space), the internal timer is loaded with a count of 128, and then a countdown to 0 starts. This occurs at a time equal to half that occupied by one bit. At the sensing of a timer interrupt, when the internal timer reaches 0, the input port A bit 0 is again tested for a low (space). This is to make sure that the first space sensed was not just a noise pulse. If a logical 1 is detected (mark), the routine is ended, and the initial space detected is assumed to be erroneous. A delay routine is entered to hold off the receiver for the width of nine spaces, to ensure against another false start, and then the routine is terminated until another space condition is sensed. If a space is still detected after a time equal to a half data bit period, a valid data input is assumed, and the data receiving routine is entered. A count of 8 is loaded into count register DD, and then the routine waits for a timer interrupt. This occurs one full data pulse period later. At this time, the center of bit 1 of the input data should be present at the input. The centers of the input pulses are sampled regarding their being mark or space.

A receiving register AA is used to receive the input data. First, bit 0 of the receiving register is set. The level at port A bit 0 (pin 17) is sampled. If low, bit 0 of the receiving register is cleared; if high, it is left set. Then the receiving register is rotated left through carry, and the holding register AA is rotated right (remember we sent MSB of the data first) through carry. The bit counter DD is decremented, and this routine is repeated until all eight bits have been received. Now, the original data that were at the transmitter input are held in holding register BB. The next routine looks for a mark at the input, indicating the presence of a stop pulse. Once a mark is detected, the timer is cleared, then port B is cleared to 0; this gets rid of any old data. The holding register BB has its contents moved to working register W and then to output port B. The receiving register AA and holding register BB are both cleared, and the routine returns to its starting point to wait for the next data pulses that are received.

Because port B is not cleared, it retains its data until the next data arrives. The data in our circuit is used to light up segments on an LED bar graph display as a demonstration. By hooking up the receiver to the transmitter through a data line and powering up both circuits, you can control each LED of the receiver by a corresponding switch on the transmitter, indicating proper indication. In practice, the wires would be replaced by a radio or telephone link with suitable interfaces, and the switches and LEDs would be replaced by input data and an output device, which could be any kind of loads, controlled systems, a computer, or the like. Except for the use of switches instead of LEDs, it looks very much like the transmitter.

We hope that this chapter has demonstrated a simple data link setup. Applications for control purposes are left to the ingenuity of the reader. Many applications are possible, and the software can be modified to suit your individual needs. Routines for these chips are given in Figures 17-3 and 17-4.

This Page Intentionally Left Blank

18. RF Field-Strength Meter for 500 kHz to 3 GHz Transmitter

Among the newer RF devices on the consumer market are a wide variety of low-power transmitters. These include cell phones, remote control transmitters for garage door openers, carrier-current devices, wireless computer peripherals such as mice and keyboards, and PCS devices. Also, many small devices are sold for surveillance use, such as small FM transmitters and other “bugs.” In addition, 900-MHz wireless video cameras, video transmitters, and low-power FM stereo transmitters are also widely used. Ham, CB, and family radio transceivers small enough to fit in a shirt-pocket are commonly used as well. These devices can be used in one form or another as spy devices (“bugs”). This field-strength meter can locate “bugs” or other hidden transmitters, can be used to set up and adjust antennas, and can test the operation of remote control and other low-power transmitters. It will detect the signal produced by remote control transmitters a few feet away, to see if they are “putting out” signal.

It is also useful for checking ham and CB antennas and low-power Part 15 transmitters, in the FM and AM bands. It will also spot sources of RF and RF interference from devices such as light dimmers, fluorescents, and switching supplies. It even checks the electronic car “keys” used by many new cars for RF output. All of these devices produce RF fields. It is also useful for checking small transmitters such as cell phones, amateur radio walkie-talkies, family radio (UHF walkie-talkies), and CB transmitters. It even checks microwave ovens for leakage and can detect an operating microwave oven 10–12 feet away. It can be used to reveal the possible RF hazards from these devices as well.

Small, relatively high-power (1–5 watt) VHF and UHF transceivers are common. The high operating frequency of these handheld devices allows small antennas of 5–20 cm length to be used. The result of this is the generation of an intense RF field in close proximity to the antenna. The antenna may be as close as a few centimeters from vital body structures, such as the brain or the eyes. This may be the case when a cell phone or walkie-talkie is held close to your face, as is often done because the microphone and speakers are integrated into these units. The allowable RF power density that might be harmful is easily exceeded in such cases.

Assume that the antenna of a low-power transmitter in use is located 10 cm (4 inches) from the body and that 500 milliwatts (mW) is being radiated from the antenna. Consider a sphere of 10-cm radius around the antenna. The total area of this sphere is equal to:

$$\text{Area} = 4\pi r^2 = 4 \times 3.14159 \times (10 \times 10) = 125.6 \text{ cm}^2$$

Because 500 mW is being radiated, the average power density crossing the surface of this sphere is:

$$\text{Power} \div \text{Unit area} = 500 \div 125.6 = 3.98 \text{ mW/cm}^2$$

This is almost four times the 1 mW/cm^2 that is thought to be hazardous, and this assumes an ideal isotropic radiator. (In Australia, a power density level of 0.2 mW/cm^2 or more is considered hazardous.) In practice, there are peaks and valleys in any antenna and ground (composed of the device PC board and case assembly plus other metal parts), and at distances closer than about 0.159 wavelengths from the antenna, the near-field components must be considered. Note that this equals $1/2\pi$ wavelengths and is a mathematical approximation, and no real sharp boundary exists between near- and far-field regions. Nevertheless, the radiated power still has to cross this spherical surface. In addition, note that 5-watt VHF and UHF walkie-talkies are common, and antennas are often held closer than 4 inches from the body. So you can see that it is easily possible to develop power density levels of more than 1 mW/cm^2 with any of these devices. The safe exposure limit is not known to any degree of accuracy. The authors have seen various low-cost devices available to measure power density level.

Realistically, the accurate measurement of this level requires laboratory-grade test equipment, with accurate and traceable calibration, such as calibrated standard antennas, an accurate power meter, a spectrum analyzer or other accurately calibrated receiver, and a proper test environment. Furthermore, many of these meters are aimed at one specific frequency range and/or type of RF emission. This approach limits their usefulness and can lead to a false sense of security. Many other frequencies may be present. It is highly doubtful that any \$100 meter sold for service or consumer use is going to have anything approaching useful calibration. Too many factors and sources of errors are not accounted for. What is useful is a device pointing out the sources and locations of local RF fields. Then, by knowing the power, frequency, and other characteristics of these sources, calculations can be made using nomographs or simplified worst-case mathematical formulas.

Suitable relationships can be found in books such as the ARRL publication *RF Exposure and You*, by Ed Hare, W1RFI. This is an excellent, user-friendly work for the average experimenter who doesn't have a degree in electrical engineering or physics. This approach would most likely be better than trusting an inexpensive meter of dubious calibration. The RF field exposure problem is real and definite. Excessive exposure can lead to health problems and even organ damage. Cases of cataracts and eye damage caused by microwave energy "cooking" the eye structures have been reported. For example, looking into a waveguide that is connected to an energized microwave transmitter can cause this problem. Another case we have heard about concerned "cooking" of the abdominal organs of a technician who stood directly in the beam of very high-power radar. Remember the microwave oven in your kitchen—RF can cook and kill. So you should exercise some caution, even with relatively low-power (less than 100-watt) devices. If you still doubt this issue, consider the following example:

An X-band (around 10 GHz) waveguide has a cross-sectional area of around 0.33 square inches or 2.3 square centimeters. A transistor oscillator putting out 10 mW would produce a power density of 4.3 mW/cm . A 1-watt transmitter would produce 430 mW/cm . As anyone who has been on the bench has learned, 1 watt in a small area (for instance, a transistor with no heatsink, dissipating 1 watt of power), can get very hot. Someone who would be foolish enough to look straight into this X-band waveguide carrying 1 watt could definitely fry an eyeball. The moral of the story is obvious: Power density, not power level, is the culprit.

Other devices, such as body transmitters used in surveillance, operate in close contact with the body. Accidental RF exposure can also occur from mobile two-way

radios installed within a vehicle, running considerable RF power to the antenna. Approximately 25–100 watts is commonly used in these systems, operating in the 470- and 860-MHz ranges. Many city dwellers live in tall apartment buildings with rooftops festooned with radio repeaters and antennas, often several running at once. The cell phone and cancer controversy has even been written about in the news recently.

The FCC requires amateur radio operators to fill out an RF exposure hazard statement on license renewal, wherein the worst-case exposure to any personnel in the vicinity of the antennas must be estimated. This may require certain antenna and/or power restrictions so as not to exceed stated exposure limits. These measures may include relocating the antenna, mounting it higher, using a protective fence, or reducing power at the transmitter. With all of the RF sources present in our modern environment, it might be wise for a person to have some means of detecting strong RF fields that may pose a health hazard. This chapter describes such a device, covering 100 kHz to 3 GHz. This range would include almost all sources likely to be encountered around the average home. VLF (less than 100 kHz) transmitters are uncommon and obvious to anyone via their gigantic antenna farms. Microwaves are generally aimed in tight beams away from buildings and are unlikely to be found in locations accessible to unauthorized personnel.

It is often sufficient to get a relative measurement of RF field strength that is produced by a transmitter or other RF generator. Exact measurement is best done with a spectrum analyzer and a specially calibrated antenna, which are expensive and beyond the means of the hobbyist or experimenter; however, the knowledge of the exact field strength is seldom needed unless measurements such as system performance, certification of equipment to FCC requirements, or detailed RF site surveys for commercial systems are needed. Also, the location of a transmitter or source of RF radiation does not need exact calibration, only relative readings (stronger or weaker, etc.). Generally, a sensitive microammeter (0–50 μ A full scale) connected to a diode detector is used for this purpose, and sometimes a DC amplifier is added to improve the sensitivity. This approach has its limitations, however, because the sensitivity is limited by the meter and the forward voltage of the detector diode (about 0.2–0.4 volt DC). Forward bias can be used to overcome this problem, but signal levels of 50–100 mV are still needed to show a reading. This limits the sensitivity of this type of meter. A DC amplifier can be used but is drift prone, and the meter generally has to be nulled (zeroed) before being used.

The meter in this project uses an active antenna preamplifier and Schottky barrier diodes for improved sensitivity. A chopper system converts the detected signal to a 700-Hz AC signal. This is amplified with a high-gain op-amp AC amplifier (up to 600 times), and the AC signal is rectified and used to drive a 20-segment LED bar graph display in the dot mode for reduced battery drain. Diodes in the feedback loop compensate for rectifier nonlinearity. This system detects signals as low as -40 dBm (2.2 mV into 50 ohms) over a range of 500 kHz to 500 MHz, with usable sensitivity from 100 kHz to 3 GHz. As with any untuned broadband detector, the strongest signal in the area will dominate. Hidden transmitters can be detected with this device, but their signals must be stronger than any other signal or a false indication may occur. For optimum performance, two separate active preamplifiers are used, one for LF and HF (100 kHz to about 30 MHz) and another for 30 MHz or higher. A front panel switch selects which preamplifier is used. A gain control allows optimum adjustment of sensitivity.

A short (2-foot) adjustable whip antenna is used for pickup, and this antenna can be removed via a BNC connector. Power is supplied at 6–9 volts by eight AA cells or

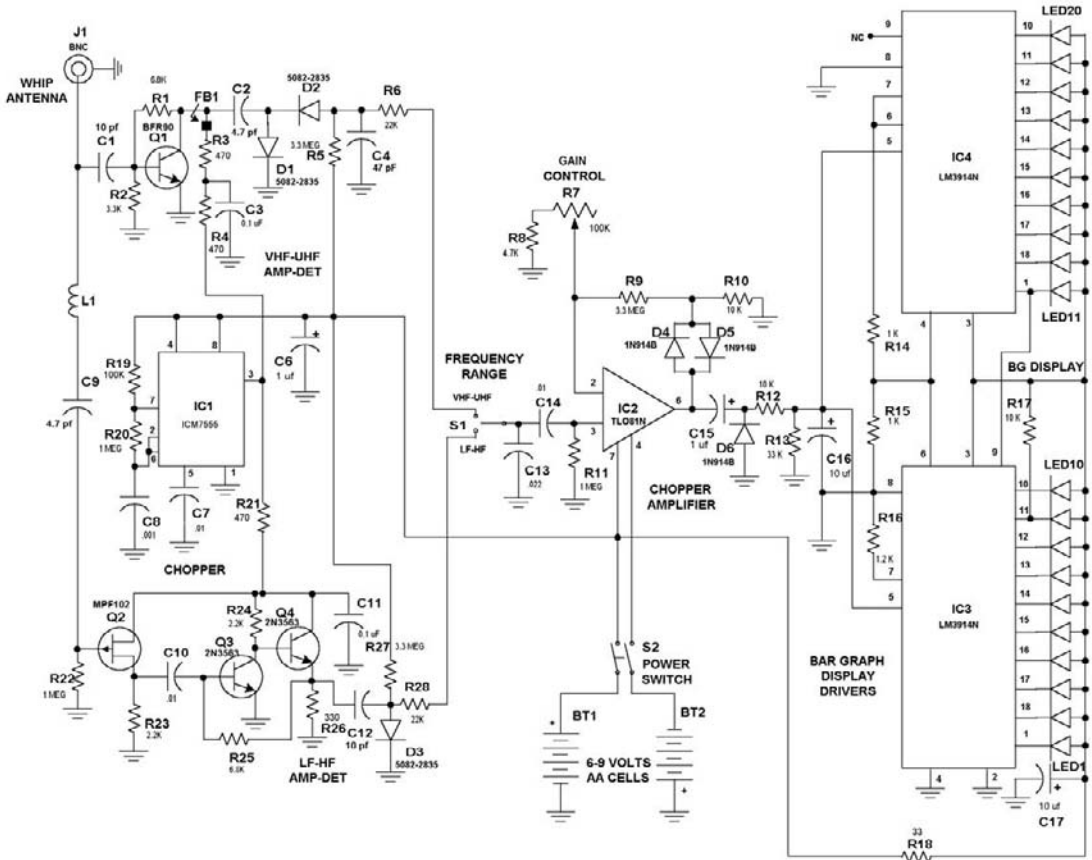

Figure 18-1
Schematic of RF Field Strength Meter

two 9-volt transistor radio batteries. Battery drain is around 20 mA, ensuring long battery life. Two ICs (ICM7555 and TLO81) and four transistors are used in the meter circuit.

Circuit Operation

The traditional approach to a field-strength meter uses a diode detector driving a microammeter. This approach works for higher-power transmitters (above 5–10 watts); however, it has poor sensitivity, requiring 50–100 mV input for a meter reading. More sensitive meters improve this limitation but are delicate and expensive. A DC amplifier stage can be used to drive the meter and improve sensitivity, but this approach usually suffers from drift and DC stability problems and has to be zeroed as the batteries age or the ambient temperature changes. In addition, sensitivity suffers at lower frequencies because the short whip antennas generally used fall off in efficiency. In this design, shown in Figure 18-1, an active antenna circuit is used for the lower frequencies and a broadband preamplifier at VHF-UHF for improved sensitivity.

The use of an AC amplifier with a chopper circuit eliminates DC stability problems. The only adjustable control used in the circuit is a gain (sensitivity) control. The LF-HF amplifier uses a hi-Z input FET stage for better sensitivity at low frequencies with a short pickup antenna. The VHF-UHF amplifier uses a BFR90 UHF bipolar transistor for wide bandwidth and has about 10-dB gain. This approach proved better than the use of a microwave IC because less current is needed and higher signal levels can be handled. The BFR90 output more than 1.5 volts to the diode detector, whereas the MMIC produces only 300 mV and must be terminated in 50 ohms. Because the diode detector is high impedance, the MMIC is inefficient because it is generally designed to operate into low-impedance terminations. The RF field-strength meter circuit responds to a -47 dBm signal level at 100 MHz, with usable sensitivity to 3000 MHz. A switch selects which RF preamplifier is to be used for best sensitivity.

Considerable overlap exists, and either preamplifier can be used in the 10–100 MHz range. The FET amplifier gives better sensitivity at low frequencies, whereas the bipolar preamplifier is best at higher frequencies. The meter readily registers static crashes during an electrical storm (mainly components less than 10 MHz) and is sensitive enough to detect low-power FM “bugs” of a few milliwatts output at distances of several feet, enabling this meter to be used as a “bug” detector, to check if a person is carrying a hidden transmitter or if a phone is bugged; however, similar to all broadband passive detectors of this type, it will respond to the strongest signal present at its input. Making the detector too sensitive causes it to give false indications from strong broadcast and commercial signals and possibly RF noise present in the immediate area. A sensitivity of 1–5 mV is adequate for bug detection, yet not enough to pick up normal-level RF signals from closeby broadcast and commercial stations.

The circuit, shown in Figure 18-1, operates as follows: A 2-foot (60-cm), collapsible whip antenna connected to J1 picks up RF signal. This signal can be anywhere in the 100 kHz to 3 GHz range. Higher-frequency signals (more than 30 MHz) tend to be opposed by L1 and are coupled to preamplifier Q1 via C1. Lower-frequency signals see C1 as a high impedance in series with the low-input impedance of Q1, and L1 as a low impedance. The low-frequency signals are coupled to the gate of FET Q2 via C9. The gate of Q2 has a very high-input impedance (more than 100K ohms) to lower-frequency signals, and C9, although small, has a negligible effect. The VHF-UHF preamplifier consists of Q1 and a few bias resistors. R3, R1, and R2 bias Q1, a BFR90 UHF bipolar, to about 3 volts and 5 mA collector current. The gain of the bipolar preamplifier is approximately two to three times voltage gain. FB1 acts as an RF choke, and signal is coupled to voltage doubler/detector diodes D1 and D2. These are hot carrier diodes for better sensitivity. R5 provides a slight DC bias for improved sensitivity to low-level signals. C4 is an RF bypass, and the detected signal is taken off via R6 to be amplified by IC2.

The low-frequency preamplifier is fed from source follower Q2. R22 returns the gate of Q2 to ground, while R23 provides source bias. C10 couples signal into a feedback pair amplifier consisting of Q3, Q4, and bias resistors R24, R26, and feedback resistor R25. The overall gain of the LF preamplifier is about three to five times voltage gain (antenna to detector). C12 couples RF signal to detector diode D3, which is also a hot carrier diode. Because the preamplifier gain is higher than the Q1 stage, a voltage doubler configuration is not needed here. D3 is also a hot carrier diode and is slightly forward biased by R27. Detected signal is taken off through R28.

Both preamplifiers are fed chopped Vcc from timer IC IC1, an ICM7555. This is a CMOS version of the popular 555 timer IC. R19, R20, and C8 form an RC network

to produce a nearly symmetrical squarewave. Exact symmetry is unimportant here. C7 is a bypass capacitor for noise suppression, and C6 is a Vcc bypass capacitor also for noise suppression. Vcc is fed to pins 4 and 8, and chopped Vcc appears at pin 3. C3 is a despiking capacitor to reduce fast transients. R4 and C3 control waveshaping to preamplifier Q1, and R21 and C11 do the same for the lower-frequency preamplifier. The effect of using a chopped Vcc supply for both preamplifiers is to amplitude modulate their RF outputs. This allows an AC component to appear on the detected signal, which is later amplified rather than the DC component. The lower limit of detectability is about 5–10 mV at the detector, which is limited by the presence of chopping noise spikes and the square law effect of the detector at low levels. With the preamplifiers, this allows 2-mV input signal levels to be detected.

IC2 is a TLO81 FET op-amp that performs all of the amplification functions needed in this circuit. It is powered by two supplies: a positive and a negative battery supply. This simplifies biasing, and battery life is long, approaching shelf life for the negative battery supply BT2. The positive battery supply BT1 has to carry the preamplifiers and LED display and must provide 20–30 mA, but for the intermittent nature of the use of this device, the battery life should be long here also. S2 is the power switch for the battery supply. S1 is a selector switch that connects one of the detector outputs to the AC amplifier IC2. This op-amp is biased to 6–9 volts and is set for a gain of between 30 times and 600 times via gain control R7 and limiting resistor R8. D4, D5, and R10 compensate for the nonlinearity of the rectifier diode D6. Amplifier output is coupled to D6 via C15. DC output is fed to network R12, C16, and R13, which filter the output and remove AC components and determine the ballistic characteristics of the “meter” formed by the LED display. The meter acts like an analog mechanical movement. The meter has a full-scale deflection of around 3 volts. At full gain setting, this allows an RF input signal of 5–10 mV to produce a full-scale indication. This corresponds to maximum gain setting of R7 (minimum resistance).

The meter consists of IC3 and IC4, a pair of LM3914 LED segment drivers, and two 10-segment LED bar graph assemblies cascaded to give a 20-segment meter. This is sufficient resolution (5 percent full scale) for our purposes. Red LEDs were used, but any other color or combinations of colors may be used as long as all LEDs are driven with the same DC current levels. The use of separate, individual LEDs is permissible. R14 and R15, with R16 set up the LM3914s for cascaded dot mode operation. Bar graph mode operation could be used, but battery drain when 20 LEDs are lit (full scale) would approach 200 mA. Dot mode saves battery drain because only one or two segments at a time are lit. R17 cuts off LED10 when any of the LEDs 11 to 20 are lit, and C17 with R18 form a filter network to suppress a tendency for the display to be unstable because of possible RF oscillation. In addition, R17 limits the maximum possible LED current in case of a short circuit, avoiding damage to individual segments.

Power is supplied from the circuit using two 6- or 9-volt batteries. A voltage divider or active splitter using an op-amp would permit only one battery to be used, but it was not really worth the extra parts because large decoupling capacitors would be needed. Only a few milliamperes of negative supply are needed, and the battery life will approach shelf life with such a light drain. The positive supply must handle 20–30 mA. We used two sets of four AA batteries, which are cheap and simple and fit the case perfectly. Alternately, two 9-volt batteries could also have been used. The circuit operates down to 3.5 volts or so.

Before beginning construction (see Figures 18-2 and 18-3), carefully identify all parts against the parts list. Use good lighting while assembling the transmitter. A

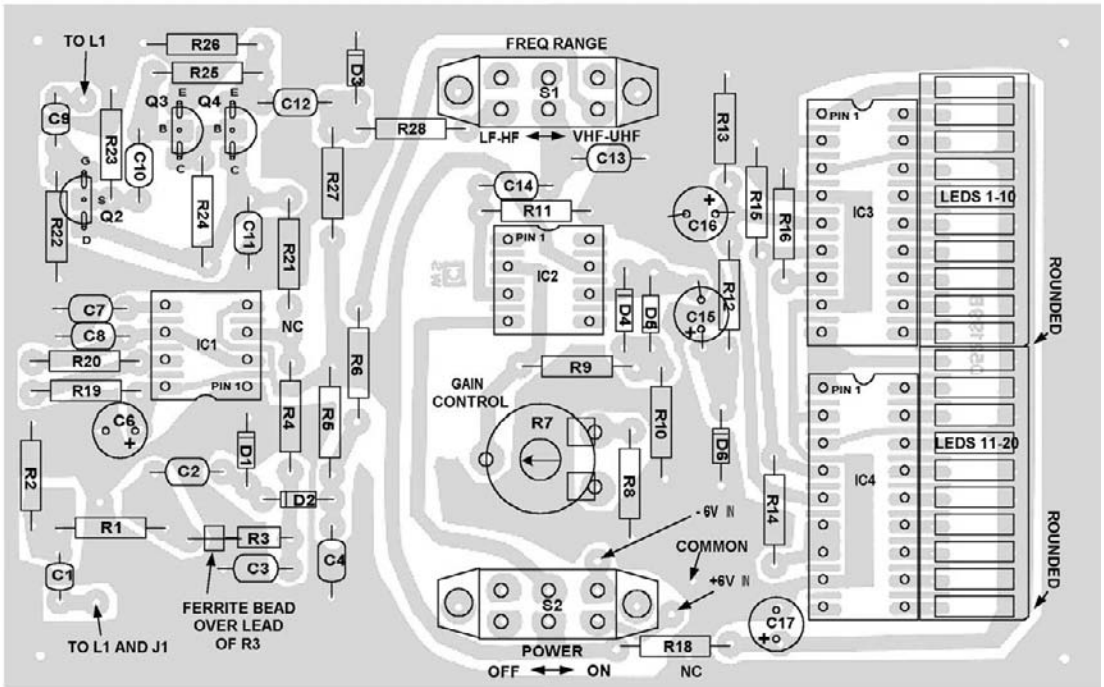

Figure 18-2
Parts Placement of RF Field Strength Meter Component Side

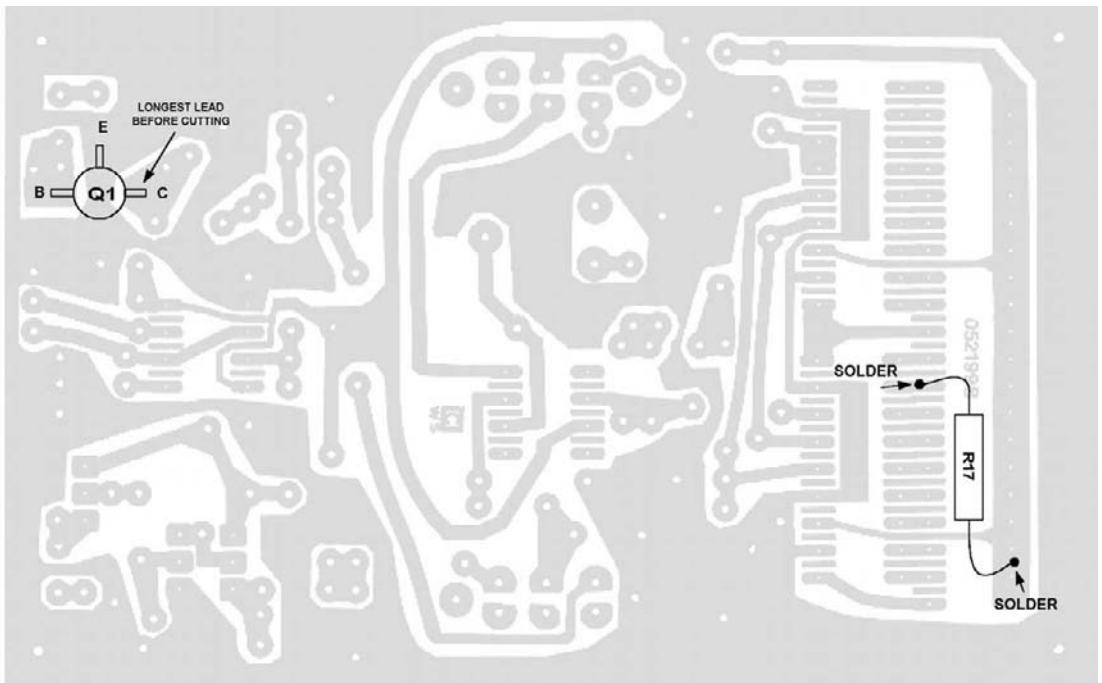

Figure 18-3
Parts Placement of RF Field Strength Meter Solder Side

magnifier is helpful to see certain color codes and small part numbers. Check any dubious items with a VOM to be sure. Low-profile DIP sockets can be used to facilitate experimentation and replacement of ICs and LED bar graph displays. Sockets are recommended if you prefer to avoid directly soldering IC chips in the board. The long lead on Q1 is the collector. When trimming it to length, it is a good idea to cut the end diagonally to distinguish it from the other leads. The center lead is the emitter, and this lead is soldered directly to the ground plane, with the lead as short as possible. If you like, you may mount the board in a case with batteries and jacks before testing; however, if any assembly errors are found, access to the circuit board will be more difficult.

Test Procedure

In order to test the circuit board, a power supply of ± 5 to 9 volts should be used. Note that this is actually two separate supplies of the same voltage but with opposite polarity. Connect the power supplies to the circuit board at the points shown in the parts placement diagrams. Make sure S2 is in the OFF position when connecting the power supplies. After checking your wiring, turn on S2. The LED display should flash briefly and return to 0. Rotate R7 fully counterclockwise (minimum gain). Check for the following voltages:

- Pin 7 IC2: +5 to +6 volts
- Pin 4 IC2: -5 to -6 volts
- Pin 6 IC2: 0-1 volt
- Pins 4 and 8 IC1: +5 to +6 volts
- *Pin 3 IC1: +2.2 to +3.0 volts
- *Collector Q1: +1.1 to +1.7 volts
- *Base Q1: +0.3 to +0.4 volt
- *Drain Q2: +1.3 to +1.8 volts
- *Source Q2: +0.7 to +1.3 volts
- Collector Q4: +1.3 to +1.8 volts
- *Base Q3: +0.3 to +0.4 volt
- *Emitter Q4: +0.35 to +0.5 volt
- Pins 6, 7 of IC4: +1.2 to +1.5 volts
- Pin 4 IC4: +0.6 to +0.8 volt
- Pin 6 IC3: +0.6 to +0.8 volt
- Pin 7 IC3: +1.25 volts
- Pin 3 IC3: +4.5 to +5.7 volts

Note that this test was made with 5-6 volts. You may later use a 9-volt battery supply for both batteries if desired, but the meter should work with somewhat less than 5 volts, to allow for gradual battery exhaustion.

* should be measured with a scope

If all voltages are in reasonable agreement with these readings, you may assume that everything is correct. If you have access to a signal generator, apply a 10-mV RF signal at 1 MHz to J1. Place preamplifier selector S1 in the LF-HF position. Adjust R7 fully clockwise (maximum gain). The LED meter should indicate at least three-quarters full scale. Place the preamplifier selector switch in the VHF-UHF position and repeat the test at 100 MHz. You should get similar results. If you do not have a suitable signal generator, try bringing the meter with a 2-foot antenna very close to a fluorescent lamp of at least 40 watts. Some indication should show with S1 in the LF-HF position. A computer monitor or TV screen should also show some indication if the antenna is brought close. Be careful not to blow the LF-HF preamplifier FET from electrostatic discharge, so first turn on the monitor and gradually approach it. In the VHF-UHF position, a cell phone several feet away should produce an indication if the meter is working, or you can use any other VHF-UHF source, such as a 2-meter ham rig or a CB radio, to check if the meter is operating. A garage door opener or RF-operated remote control can also be used. Note that the first segment or two of the LED display may light with no input if R7 is advanced to full gain. This is not significant. Rotate R7 to just barely extinguish the display in this case. In a dimly lit room, a faint glow may be seen from some segments that normally should be “off.” This is normal and should be ignored.

Packaging

It is recommended to package the meter in a plastic or metal case. Use a 1:1 size layout of the PC board to locate the holes for the display and the switches and R7. A BNC jack can be mounted on top of the meter to use as an antenna connection. A 2-foot, collapsible whip antenna is recommended, and this should be fitted with a BNC connector to mate with J1. A suitable antenna can be purchased from the source shown at the end of this chapter. A case and a complete kit of parts and a drilled and etched board are also available from the same source. Packaging is not critical, and you can do this to suit your own preferences. Battery supplies (6–9 volt) are required, and you can use AA, AAA, or 9-volt alkaline types with suitable holders. The battery holders can be mounted inside the case, in the rear half, with the circuit board mounted as shown to the front half of the case. Three wires are needed from the battery pack to the circuit board, and a lead from the antenna jack J1 should run to the preamplifier inputs. A short length of coaxial cable is used to connect the VHF-UHF preamplifier directly to J1, and a length of #20 wire is used to both form L1 (not critical) and connect to the LF-HF preamplifier input as shown in the figures. If a plastic case is used, this wire will form an adequate UHF pickup antenna for 400–3000 MHz. A metal case will shield this pickup, so an external antenna will be needed at J1. If you prefer, a plastic filter can be used over the LED display (use red for red LEDs, or a matching color for other LEDs you may use, for best visibility). We did not use a filter because none was found necessary (see Figures 18-4 and 18-5 for details).

Figure 18-4
Assembly and
Packaging of RF
Field Strength
Meter

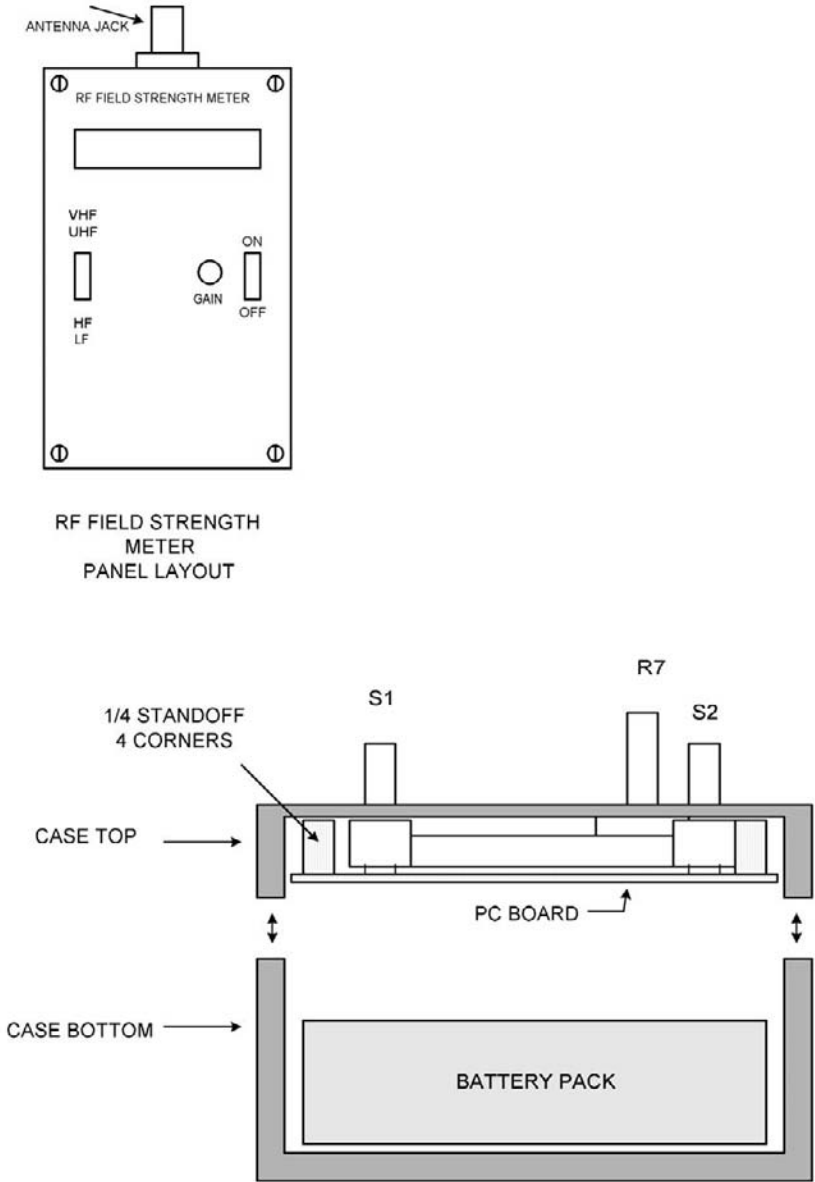

RF Field-Strength Meter for 500 kHz to 3 GHz Transmitter

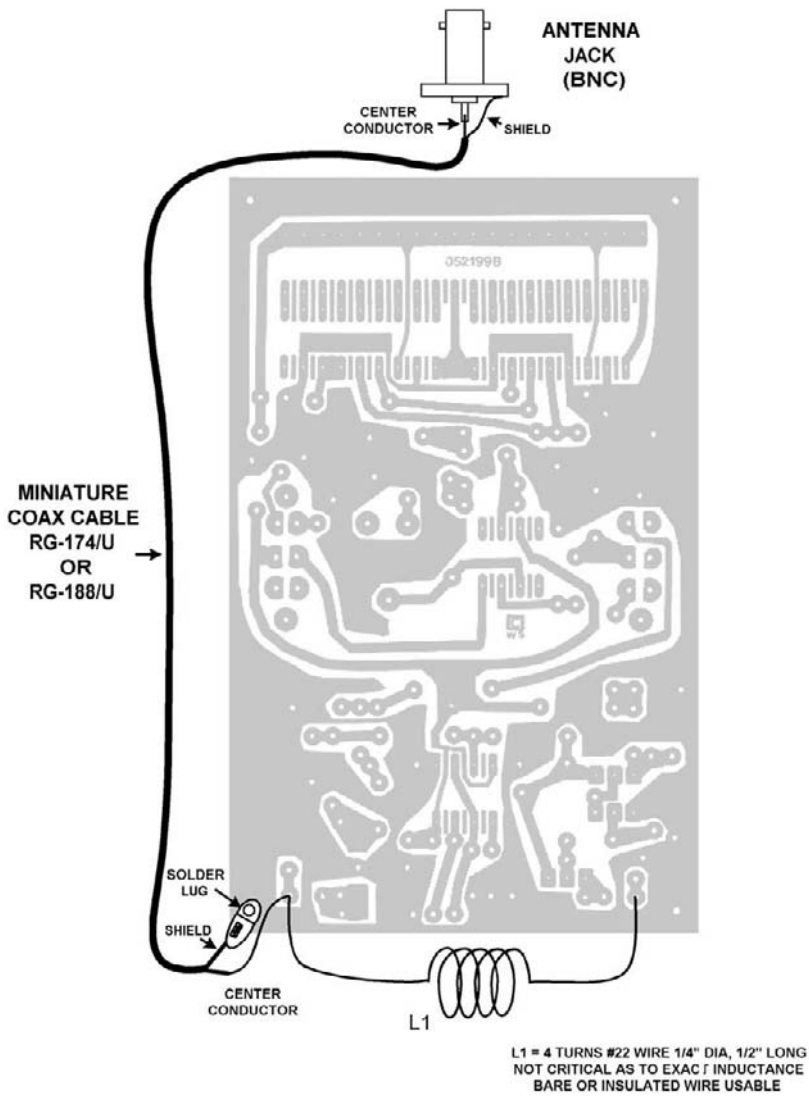

Figure 18-5
Wiring of Antenna
Cable and L1 of RF
Field Strength
Meter

Figure 18-6
PC Board Pattern
for Solder Side of
RF Field Strength
Meter

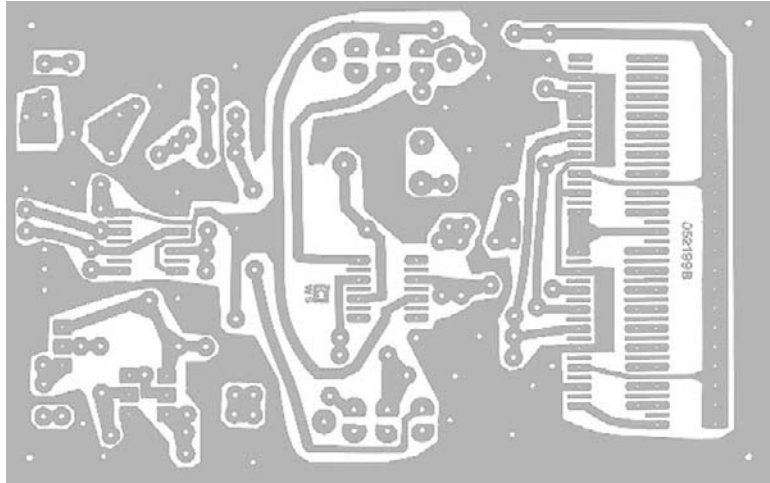
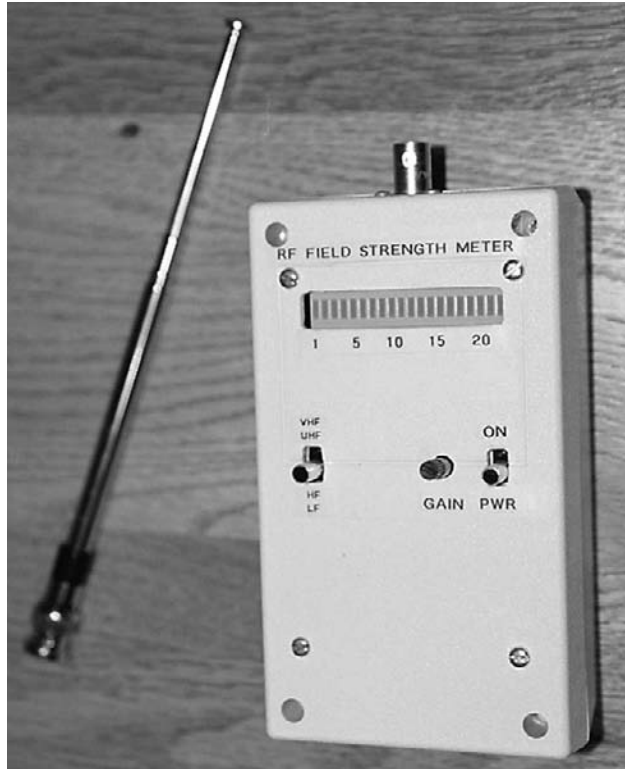

Figure 18-7
Photo of Com-
pleted RF Field
Strength Meter
with Matching
Antenna



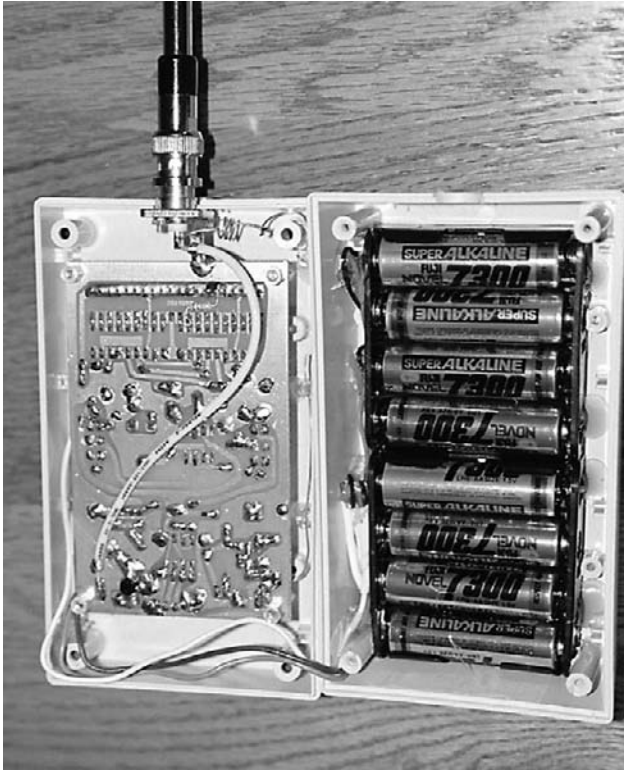

Figure 18-8
 Inside Photo of
 Completed RF
 Field Strength
 Meter Showing
 Battery Pack

Parts List

Resistors 1/4W 5%		Capacitors	
R1, R25	6.8 Kohm	C1, C12	10 pf NPO
R2	3.3 Kohm	C2, C9	4.7 pf NPO
R3, R4, R21	470 ohm	C3, C11	.1 Mylar 50V
R5, R9, R27	3.3 Mohm	C4	47 pf NPO
R6, R28	22 Kohm	C7, C10, C14	.01 uf 50V ceramic
R7 PT10 pot	100 Kohm	C13	.022 uf mylar 50V
R8	4.7 Kohm	C15	1 uf 35V elec
R10, R12, R17	10 Kohm	C16, C17	10 uf 16V elec
R11, R20, R22	1 Mohm	C5	Not used
R14, R15	1 Kohm	C8	.001 Mylar

Build Your Own Low-Power Transmitters: Projects for the Electronics Experimenter

Resistors 1/4W 5% (cont.)

R16	1.2 Kohm
R18	33 ohm
R19	100 Kohm
R23, R24	2.2 Kohm
R26	330 ohm

Diodes

D1 through D3	HP 5082-2800 or 5082-2835
D4 through D6	1N914B or 1N4148

Integrated Circuits

IC1	TLO81N
IC2	ICM7555
IC3, IC4	LM3914N

Miscellaneous

S1, S2	DPDT slide switch
J1	BNC Jack-or other connector of your choice
L1	4 T #22 Bare wire 1/4 inch dia
1 ea	PC Board
BT1, BT2	6 to 9 volts see text
1 ea	Plastic case
1 ea	Antenna 2 ft collapsible
1 ea	Hardware as required

A complete kit of parts, including a suitable plastic case, PC board, all parts, and complete documentation is available from the following supplier:

North Country Radio
P.O. Box 53, Wykagyl Station
New Rochelle, NY 10804-0053
E-mail: support@northcountryradio.com
Website: www.northcountryradio.com

Check their website for current price and an order form.

19. Low-Power CW Transmitter for 40 Meters

The 40-meter amateur band, lying in the lower-middle HF spectrum from 7.0–7.3 MHz (U.S. allocation, 7.0–7.15 MHz in some parts of the world) has long been a popular band for CW operation. Although some considerable interference exists in the 7.1–7.3 MHz sections from high-power AM international broadcast stations, the CW portion of the band from 7.0–7.1 MHz is relatively free from this interference and is a popular spot for CW operating. This band has several advantages. Antennas are reasonable in size (a half-wave dipole 66 feet long at 30- to 35-foot height works well). Distances of several hundred miles can be covered in daylight all year long, and thousands of miles are possible at night. Static levels are generally not too bad, and the relatively low frequency allows the use of noncritical circuitry and inexpensive parts. Several inexpensive transistors produce several watts RF output with a 12-volt supply, and generally no frequency multiplication is needed because crystals for this frequency range are easy to come by and a stable VFO is not too difficult to build if VFO control is desired.

We discuss a crystal-controlled transmitter because low-power operation is often crystal controlled, and 7040 kHz is currently (year 2000) a popular frequency for these types of transmitters, known as “QRP rigs.” This name comes from the Morse code abbreviation QRP, which stands for the act of lowering transmitter power. This transmitter is “flea powered,” running 0.25–0.5 watts, with a 9- to 12-volt supply. With a good antenna, it is possible to make contacts almost anywhere in the world, with suitable propagation conditions, and under normal daytime conditions 500 miles is usual.

One objective in the design process was to make this a “no-tune” transmitter. This eliminates adjustments and is desirable so this project can be built by the novice amateur with little experience and limited test equipment. The resulting circuit is broadband and, while designed for 40 meters, the components in the output harmonic filter could be simply doubled in value for an 80-meter version (3.5 MHz). Similarly, you can reduce component values by 30 percent to get a 30-meter (10 MHz) version. The circuit uses two transistors and a digital IC gate, a 74C00N or preferably a 74HC00N. It operates from a 9- to 12-volt supply and produces RF only when the key is pressed.

Looking at the schematic in Figure 19-1, it may appear somewhat unconventional to someone used to more “traditional” approaches using vacuum tubes or bipolar transistors; however, performance is good and no tuning adjustments are needed. The oscillator circuit uses a digital IC gate, of which one section acts as a Pierce crystal oscillator. This oscillator uses fundamental mode crystals, and we used an old World War II surplus FT243-type 40-meter crystal. Plenty of these crystals are still available at hamfests, swap meets, and in surplus dealers’ stocks. You may also use standard and more modern HC49/U or HC25/U crystals, but the old FT243

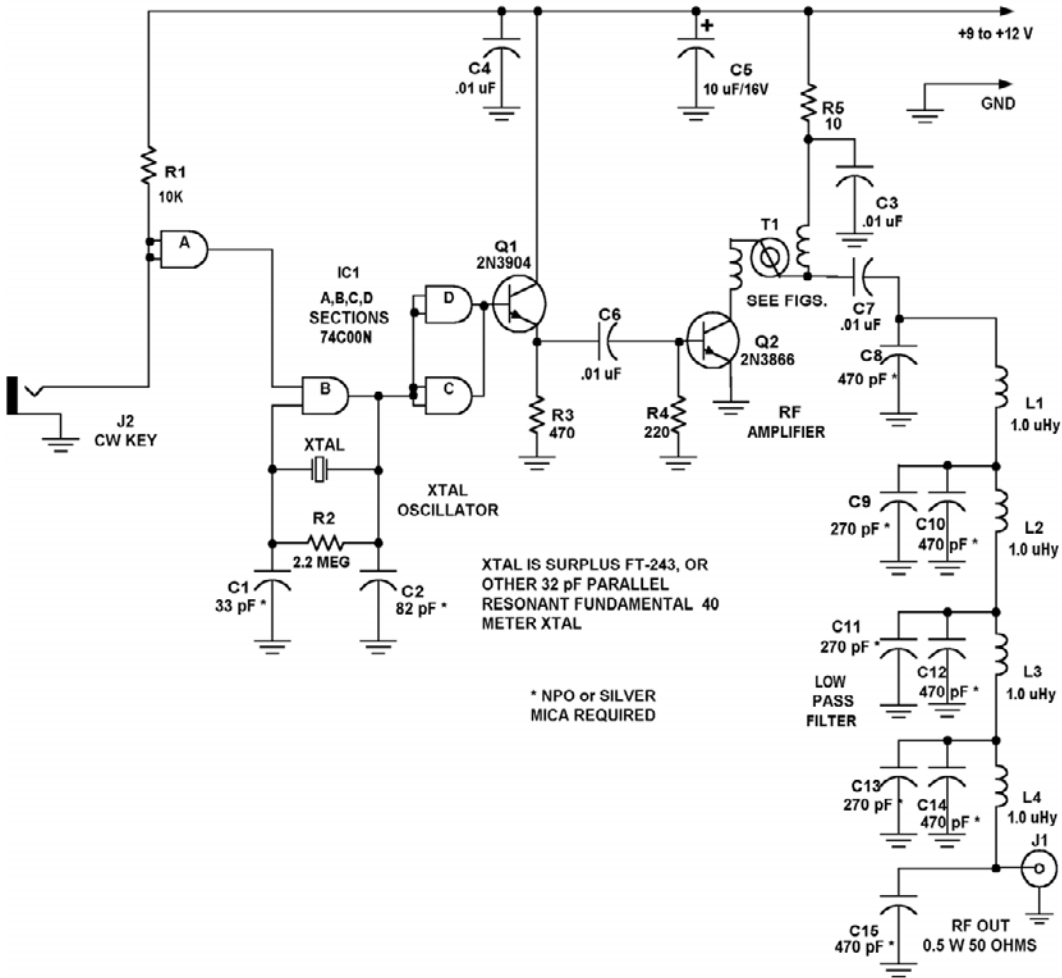

Figure 19-1
Schematic of 0.5 W 40 meter No-Tune CW Transmitter

types are cheap and rugged. R1 is a bias resistor for oscillator gate IC1B, and C1 and C2 are feedback capacitors. C1 may be made variable as a fine frequency adjust, but we found this unnecessary. Use a 10–100 pf variable trimmer here if this feature is desired. IC2A is used as a keyer, only producing a DC logic high if the CW key connected to J2 is depressed. IC1A acts as an inverter and supplies keying voltage to oscillator section IC1B. The oscillator produces an output only if the logic level on pin 3 of IC1A is high. Therefore, the oscillator functions only when the CW key is depressed. During keyup times, pin 6 of IC2B is high. The remaining two sections of IC1, C and D, are paralleled and used as a buffer for driving emitter follower Q1.

Q1 supplies current gain and drives output amplifier Q2. C6 is a coupling capacitor. R3 biases Q1, and R4 provides base bias for Q2 in the presence of RF drive from the emitter of Q1. Q2 is a class C amplifier. The collector circuit of Q2 is matched to a 50-ohm load via broadband transformer T1 (see Figure 19-2) and blocking capacitor C7. Decoupling resistor R5 and bypass capacitor C7 supply DC to the RF output stage Q2.

Twist two 30" lengths of #32 enamelled wire 4 to 10 twists per inch. For ease of identification, use wires with different color enamel insulation.

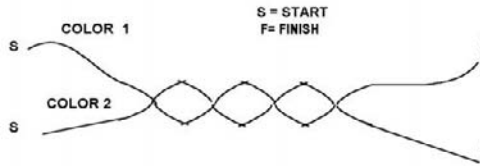
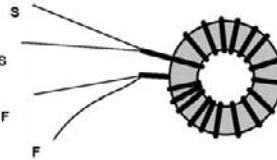
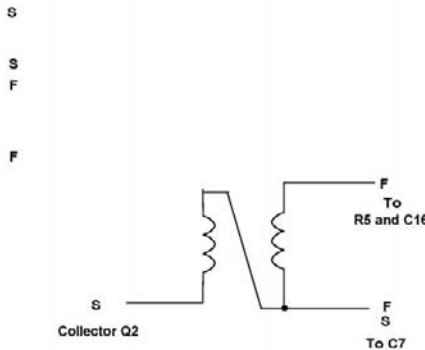

Figure 19-2
Coil Data for the 40
Meter CW Trans-
mitter

Wind 15 to 20 turns of this twisted pair around a .375-inch ferrite core. Use Ferroxcube P/N 266T125-4C4 Core. Strip insulation and tin all 4 leads.



Connect finish of wire color 1 to start of wire color 2 as shown. This forms a transformer as shown.



At this point, we have RF power but with considerable harmonic energy. It is desirable to reduce this energy by about 40 dB or better so the output is a fairly clean sinewave. A lowpass filter with nine components is employed. The filter is a 0.3 dB modified Tschebychev lowpass filter, which is modified to use standard component values. This was done on a computer, and the resulting filter gives better than 40 dB suppression of all harmonics. Four chokes, L1 through L4, and capacitors C8 through C17 make up this filter. The filter values can all be doubled if it is desired to operate this transmitter on 3.5 MHz. A PC board parts placement diagram and PC pattern is shown in Figures 19-3 and 19-4.

Tuneup is simple. Connect the transmitter output (J1) to a small 50-ohm load. A 47-, 51-, (preferred value if you can get it), or 56-ohm carbon resistor of 1-watt rating may be used. Do not place this transmitter on the air until testing is done. Use a crystal of 7.0–7.1 MHz at X1 (CW subband on 40 meters). Check your wiring and then apply 12 volts to the transmitter. Very little current drain should be noticed (a

Build Your Own Low-Power Transmitters: Projects for the Electronics Experimenter

Figure 19-3
Parts Placement
Component Side
of the 40 Meter
CW Transmitter

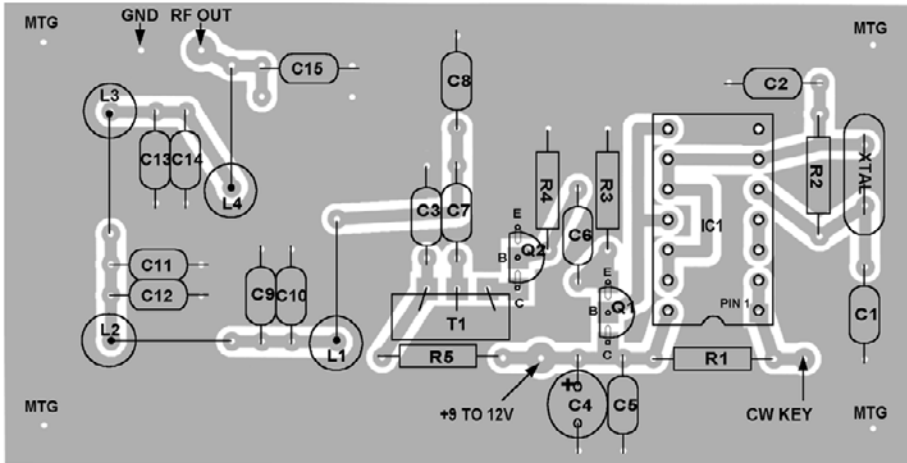
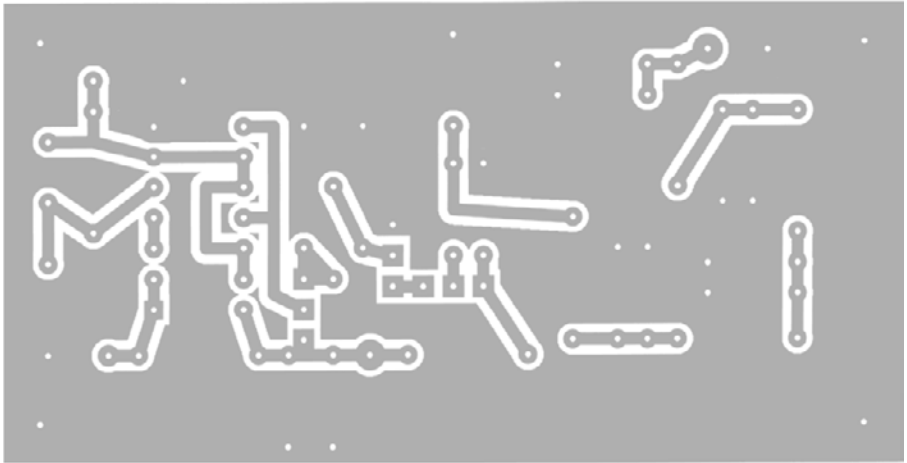

Figure 19-4
PC Board Pattern
of the 40 Meter
CW Transmitter



few milliamperes at most). Next connect a key to J2 and, while monitoring current drawn from the power supply, about 100 mA should be drawn. After a few seconds, the resistor connected to J1 should get noticeably warm, indicating RF output. A #47 pilot lamp (6.3 volts at 150 mA) or equal connected to J1 should glow to almost normal brilliance (if a 12-volt supply is used) when the key is depressed. This is a good visual test of adequate RF output. Next, listen to the transmitter, while connected to a dummy load, on your receiver. The CW should sound good without soft edges or keying chirps.

At this point, the transmitter can be used. The antenna should be resonant at the operating frequency, have an impedance close to 50 ohms, and exhibit less than a 2:1 VSWR, with less than 1.5:1 preferred for best results. A half-wave dipole cut for 40 meters (about 66 feet or 20 meters long), mounted 10 meters or 30 feet above ground, and in the clear works well. The antenna can be fed with coaxial cable such as RG8 or RG58 types, and the use of a balun at the center of the dipole is recommended. The antenna is by far the most important component as far as your success

in making contacts is concerned, so use the best antenna you can. If you have one, an antenna tuner is recommended to get the best matching. Because the transmitter power is low, a good tuner can be constructed out of receiver-level components. See any good text on general amateur radio practice, such as the ARRL or RSGB handbooks, for information on antennas and antenna tuners. The transmitter should be mounted in a metal box, and a crystal socket should be used for X1 to facilitate crystal changing because two or more different frequencies will probably be desired. A two-pole, multiposition switch can be wired in if desired, to simplify frequency changing, with a crystal socket wired to each switch position. Make sure the 12-volt supply is clean, well regulated, and free of hum. Beware of wall transformers because they are usually not good enough. Because current drain is light and present only when the key is pressed, a battery pack consisting of eight AA cells is practical and recommended.

This Page Intentionally Left Blank

20. Single Sideband Basics

Single sideband (SSB) is an important mode of transmission that is used for the bulk of long-distance HF communication in the spectrum between 1.5–30 MHz, which encompasses the part of the radio spectrum known for years as the “shortwave band.” These frequencies have the characteristic of being able to be used for long distance, fairly dependable communication using transmitters in the 100-watt power output class and rather simple wire antennas, vertical whips, and small yagis. The lowest frequencies around 2 MHz have propagation characteristics similar to the high end of the AM broadcast band, with frequencies in the 10–18 MHz range being prime long-distance frequencies. The 20–30 MHz range has phenomenal long-distance propagation with low-power transmitters during years of high solar activity, and conversely behave more like VHF during periods of low solar activity. The period 1988–1991 was a time of high solar activity, peaking in the latter half of 1989. The years 1995–1997 were a period of low solar activity. At the time of this writing, solar activity is on the rise (late 1999) and will likely peak in 2000–2001. It is currently possible for amateur radio operators to make worldwide contacts in daylight hours on the 10-, 12-, 15-, and 17-meter ham bands (18–30 MHz) with a few watts of power and a reasonable antenna, such as a ground plane, half-wave dipole, or a simple three-element yagi. This also assumes the use of SSB and a reasonably good receiver. We discuss how SSB is generated and how the generated SSB signal is processed.

SSB is a form of amplitude modulation (AM). In AM, we have the carrier and two sideband components, which are “mirror images” of each other, if the carrier is considered as the “mirror.” The sidebands carry equal intelligence, and each is half the amplitude of the carrier wave, assuming 100 percent modulation. Because power is proportional to the square of voltage, each sideband has one-quarter of the power of the carrier. In other words, a 100-watt AM signal has two sidebands with 25 watts power in each. This means that there is a total power of 50 watts—25 in each sideband—and 100 watts in the carrier. All of the transmitted information is present in each sideband. A little thought shows that all we have to transmit is one of the sidebands because it contains all of the intelligence or information (speech, music, data, etc.). Another way of looking at this is that one 25-watt sideband has everything we need, and the other 25-watt sideband is redundant, and the 100-watt carrier has no information. These sidebands and the carrier are all radio frequency energy and can be transmitted over the air, and the carrier “carries” nothing at all.

The use of the term *carrier* probably causes more confusion and misunderstanding to those learning how SSB works. We do not need the carrier to “carry” anything. It is merely produced as a product of AM modulation and is needed only for detection at a receiver using a simple diode or envelope detector. The missing carrier in an SSB received signal can be supplied by a local oscillator in the receiver, which

is commonly referred to as the *beat frequency oscillator*. Therefore, it is not necessary to transmit the carrier. This SSB concept allows a 25-watt transmitter to be as effective as a 100-watt AM transmitter, and in practice actually better since only half the receiver bandwidth is needed for reception because only one of the sidebands needs to be passed. This gives theoretically a 2:1 improvement in signal-to-noise ratio, or 3 dB. A 100-watt SSB transmitter is four times as effective as a 100-watt AM transmitter, for a total system advantage of eight times, or 9 dB over an AM system of the same power. SSB is less affected by propagation distortions such as selective fading, in which certain frequencies fade or null out. Overall, the reliability of a communications circuit is greatly improved.

In real life, however, there is seldom a “free lunch,” and this axiom is true here as well. An SSB transmitter is more complex than an AM transmitter, must have high-frequency stability, and requires more care in setup and maintenance. An SSB receiver is somewhat more complex and places much more demands with regard to frequency stability and calibration than does an AM receiver. Modern solid-state circuitry and techniques have greatly eased things, but the statement is still true to some degree; however, most voice communications in the HF spectrum are SSB and have been for a few decades. AM is mainly used in the HF spectrum for international shortwave broadcasting and for CB radio. AM has some advantages over SSB and is preferred as an operating mode by some individuals. Some radio amateurs still use AM in the 1.8-, 3.9-, and 28-MHz bands, mainly with older or restored “antique” equipment from the 1940s–1960s era. This aspect of the ham radio hobby might be likened to the enjoyment some individuals derive from driving a classic automobile or collecting antiques and should not be looked down upon as “obsolete and spectrum hogging.”

It often takes considerable skill to restore this old AM equipment because often long-unavailable parts must be repaired or even homemade. As a group, the “AMers” are generally a lot more knowledgeable technically than most SSB operators using modern factory-built SSB equipment. They cannot send their 40-year-old equipment back to the factory for service because the factory is likely long out of business. Even if they are still in business, they would not likely offer support or be able to provide parts for such old equipment. In any event, shipping would cost a small fortune because of the weight of heavy iron transformers used in this vintage equipment. Some of this older AM equipment really sounds great and, for audio quality, makes SSB audio sound “tinny” by comparison. Restricted audio frequency response is a consequence of the design of most SSB equipment used for voice communications because sharp cutoff narrowband filters with rather nonlinear phase response and inevitable delay distortion must be used to eliminate the unwanted sideband in the SSB generation process. Several methods are used to generate SSB, but we discuss the filter and phasing methods that have been used in most SSB equipment manufactured in the past few decades. First the filter method is described.

Referring to Figure 20-1, SSB is generated as follows: Audio information at the transmitter input is first fed into an amplifier and possibly a speech compressor or clipper. This increases the average modulation level. A word of caution here: Unlike an AM signal, in which the envelope has the same waveform as the modulating waveform, the envelope waveform of an SSB signal has no direct simple relationship to the modulating signal (see Figure 20-2), and using clipping of peaks may and can introduce undesirable effects and actually degrade the signal. Compression, on the other hand, largely preserves the waveshape of the modulating signal, mainly affecting its amplitude, and can be effective in boosting the average modulation level. The

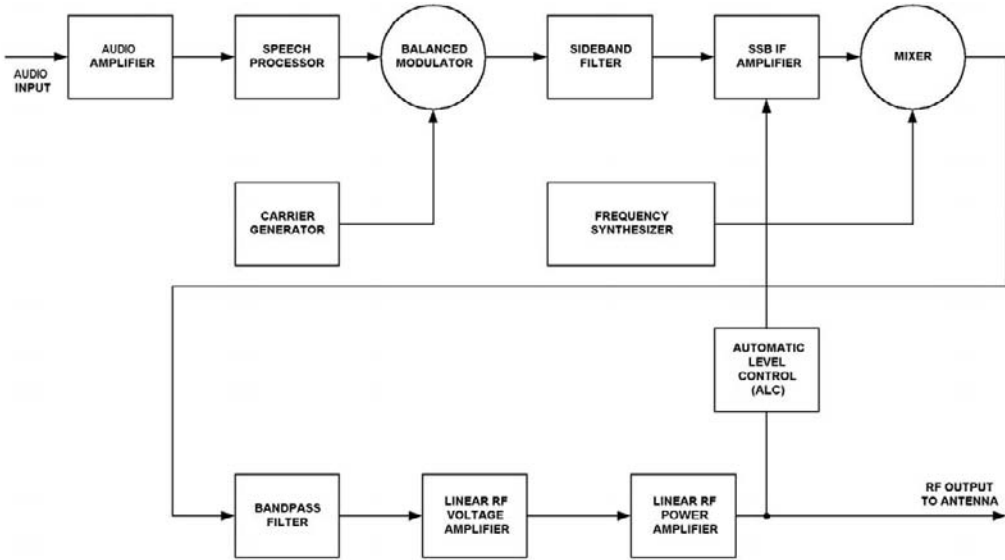

Figure 20-1
Block Diagram of the SSB Transmitter Using Filter Method

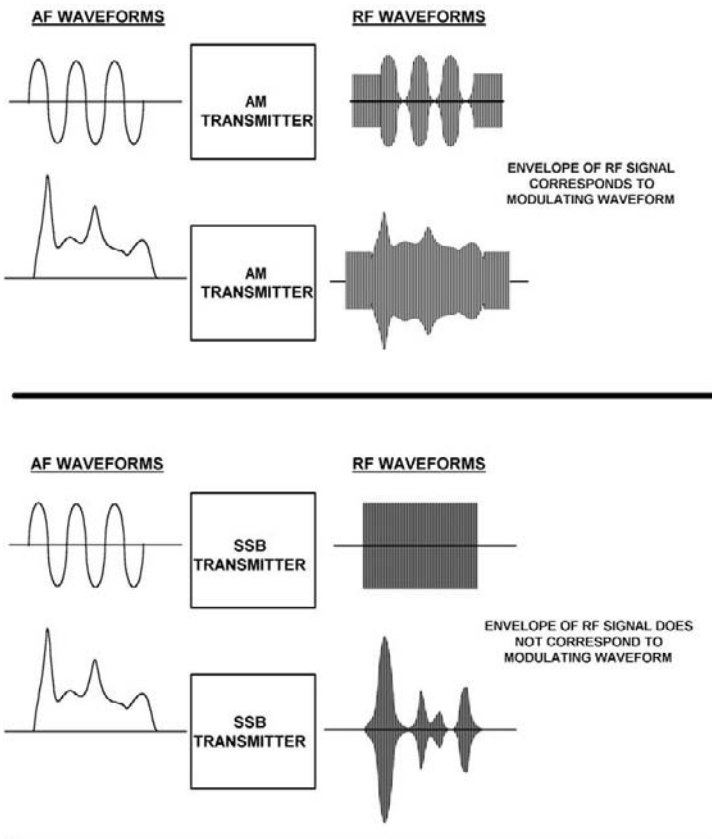

Figure 20-2
AM and Single Sideband (SSB) Transmitter Waveforms

lesson here is to avoid the all too commonly heard overclipped and overcompressed signals that are strong but nearly unreadable. The standard phrase “If enough is enough, then more is better, and too much is just right” does not apply in this case.

Next, the audio should be bandlimited to eliminate products outside the intended bandwidth. Typically, this will be 200–3500 Hz for speech, although 2500 Hz is sometimes used as an upper limit. Next, the audio is fed to a balanced modulator that is also driven with an RF carrier at the SSB generation frequency, or sometimes called the *transmitting IF frequency*. In many instances, this is the same receiver IF frequency, as often done in transceiver systems, where the same circuitry is used for modulation and demodulation. The output of the balanced modulator (actually a mixer) is a double sideband (DSB) suppressed carrier signal because the carrier is canceled out. In the absence of a modulating signal, the output is ideally zero. In practical balanced modulators, about 30–40 dB suppression of the carrier is obtained. Some provision is usually provided for optimizing carrier suppression in most circuits, although with modern solid-state, diode double-balanced mixer assemblies, inherent suppression is good enough and no adjustment is necessary. The FM stereo transmitters in this book use a double-balanced mixer operating at 38 kHz to generate the stereo subcarrier.

Next, the output of the mixer or modulator is fed to a sharp cutoff filter. This filter may be made up of LC elements (in the 10–50 kHz range) or mechanical resonators (455 or 500 kHz), or most often made from quartz crystals. Crystal filters are available at many popular frequencies as off-the-shelf assemblies. Common SSB IF frequencies that are stock crystal filters include 1.65, 3.0, 5, 9, 10.7, and 21.4 MHz, and many other frequencies are also used. The 5–9 MHz range seems most popular because crystal filters for this range are readily made. The filter should have a bandwidth (for speech) of about 2.1–3 kHz, a center frequency about 1.5 kHz above or below the carrier frequency, and 20–30 dB rejection at the carrier frequency. The filter should cut off sharply on the carrier side and have 40 dB or better rejection of the unwanted sideband. This is why crystals are used in these filters because we need the high Q values to realize this kind of rejection and bandwidth. The filter is generally one of the most expensive components in any SSB system.

An SSB generator of this type can generate an SSB signal of either lower or upper sideband. This is a function of the filter response characteristics. If capability to generate a signal of either sideband is needed, several approaches are available. First, two separate filters can be used with a switching arrangement to select the desired sideband. Alternately, a filter with a symmetrical response curve that has a sharp cutoff on each side can be used, and the carrier oscillator can be shifted to either side of the filter. A scheme that was popular some years ago used a filter at 9.000 MHz that had a symmetrical response ± 1.2 kHz from each side of center at 9.000 MHz. This gave a bandwidth of 2.4 kHz for the signal, and two separate crystals were provided in the carrier oscillator, one at 8998.5 for USB generation and another at 9001.5 for lower sideband generation. This had the disadvantage of having a 1.5-kHz nominal error in the 9.000-MHz nominal frequency, but this was corrected by shifting the LO signal ± 1.5 kHz to compensate, so the final output frequency would be correct. This is easily done in today’s transmitters via a software offset in the microcontroller used for programming the frequency synthesizer, so the entire operation is transparent and automatic.

Another method using only one filter involves using a mixer. One scheme used in the past was to generate the SSB signal at 455 kHz using a mechanical filter as the SSB filter. The output was USB from the SSB generator. Next, the 455-kHz signal is

mixed with the fourth harmonic of the carrier, 4×455 kHz or 1820 kHz, giving a USB signal of 2275 kHz, which is the IF frequency used in this system. If an LSB signal is desired, the sixth harmonic of 455 kHz at 2730 kHz is used, and the 455-kHz USB signal when mixed with 2730 kHz results in a 2275-kHz SSB signal as before, but now this is an LSB signal. This is because we are taking the difference rather than the sum. In sum mixing, the output is the sum of the IF signal and the LO signal. If the IF increases in frequency, so does the sum of the two signals. In difference mixing, when the IF signal increases in frequency, the resulting sum of the IF and LO decrease in frequency. This results in inversion of the SSB signal about the carrier frequency (in this case, 2275 kHz). This system has the disadvantage of needing a mixer and extra stages to generate the times-four and times-six signals needed to mix with the generated SSB signal, and corresponding switching arrangements, and the extra cost and complexity must be weighed against the cost of an extra filter. In amateur radio HF transceivers, a commonly used technique is the use of one symmetrical filter with corresponding offsetting the LO because the software needed in the synthesizer costs nothing once it is written and debugged and takes up no physical space. The sharp symmetrical filter is also cheaper than two separate filters, and transceiver design is simplified because the same conditions apply to both receive and transmit.

The output of the filter is a SSB signal at the IF frequency. This signal is then mixed with a stable and pure local oscillator signal from a stable VFO or frequency synthesizer. This is done in a high-level linear mixer to produce the desired SSB output frequency. A filter system then removes unwanted mixer products, and the resulting SSB signal is amplified to the final transmitter power output level, which may be a few watts to many kilowatts. A linear amplifier must be used to prevent the generation of intermodulation distortion products that appear as unwanted components and interference on the transmitted signal. Linear amplifiers may be vacuum tube or solid state. For high-power levels (more than 500 watts), vacuum tube technology is still preferred. Most transmitters in the 100-watt class use solid-state bipolar or power FET devices. Higher-power solid-state amplifiers above a few hundred watts generally need large and heavy heatsinks, power combiners, and several large, expensive transistors, together with a high current, low-voltage supply, and often sophisticated protection circuitry is needed to protect the transistors against load faults and power spikes. Vacuum tube amplifiers are smaller, can be just as or more efficient, and are more reliable, with much better immunity to load faults, such as high VSWR caused by broken, mismatched, or shorted antennas. A vacuum tube can usually stand a severe fault for a few seconds, whereas transistors can fail in microseconds. Therefore, high-power applications are often better implemented with vacuum tubes; however, for low-power transmitter use, solid state is the best approach.

Another approach to SSB generation is called the *phasing method*. In this approach, a clever phase cancellation technique is used. This method eliminates the need for a sharp SSB filter and is potentially lower in cost (see Figure 20-3). First, the audio signal after processing and bandlimiting (very important in this approach) is split into two components that are equal in amplitude but exactly 90 degrees apart in phase. This is the difficult part because a network is needed that provides a 90-degree phaseshift within ± 1 or 1.5 degrees over the entire audio range of 300–3000 Hertz. Some classes of RC networks have this property, generally involving precision components. In practice, each audio component is fed to a separate network, and while the individual network phaseshifts vary over the audio frequency range, the

Build Your Own Low-Power Transmitters: Projects for the Electronics Experimenter

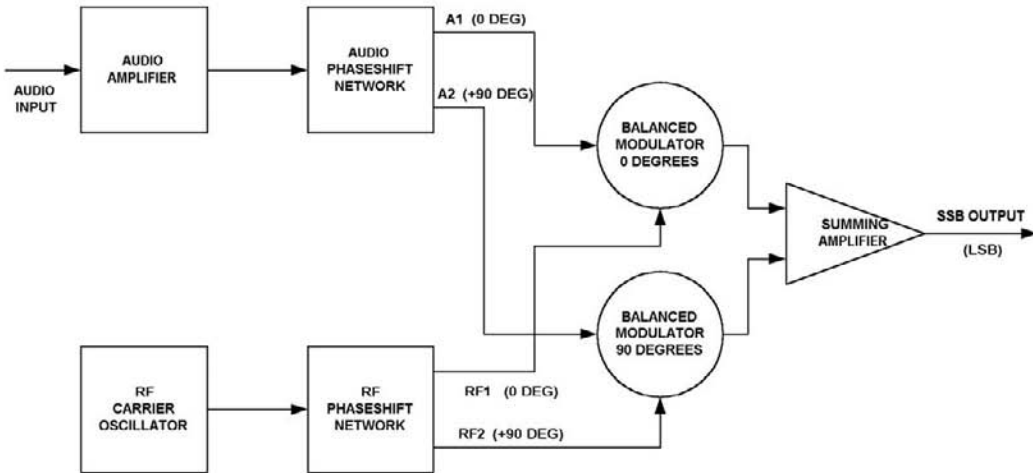

IF: $A1 = \sin WmT$
 $A2 = \cos WmT$
 and
 $RF1 = \sin WcT$
 $RF2 = \cos WcT$

$\sin A \sin B = 1/2 \cos(A-B) - 1/2 \cos(A+B)$
 $\cos A \cos B = 1/2 \cos(A+B) - 1/2 \cos(A-B)$

THEN:

$$SSB \text{ OUTPUT} = 1/2 \cos (WcT - WmT) - 1/2 \cos (WcT + WmT) + 1/2 \cos (WcT + WmT) + 1/2 \cos (WcT - WmT)$$

SUMMING TERMS AND SUBSTITUTING:

$$SSB \text{ OUTPUT} = 1/2 (LSB) - 1/2(USB) + 1/2(USB) + 1/2 (LSB) = LSB \text{ ONLY}$$

Figure 20-3
 Block Diagram of the SSB Transmitter Using Phasing Method

difference between their outputs stays within 1 degree of 90 degrees, with constant amplitude. The synthesis of these networks is beyond the scope of this book.

A schematic of a typical network is shown. It is rather simple but requires precision components. The degree of unwanted sideband suppression depends on it. Next, the two audio channels 90 degrees apart are fed to identical balanced modulators or double-balanced mixers that are driven with two carriers identical in frequency but also exactly 90 degrees apart in phase. This is easily done because the carrier frequency is generally fixed. A network consisting of RC or LC circuits can provide this 90-degree phaseshift, or a divide-by-2 frequency divider can be used. Two JK flip-flops driven by two identical clock signal squarewaves 180 degrees apart produce two outputs at half the input frequency and 90 degrees apart in phase. Next, the outputs of the two mixers are combined. It can be shown that the output will consist of only one sideband (see Figure 20-3) because the DSB signals from each mixer have phase relationships such that one of the sideband components has opposite phase with respect to the other, and the other is in phase.

Sideband selection is accomplished simply by reversing the phase of either one audio or one carrier channel. In practice, the audio channel method is usually used. Although it is a good method, the phasing method requires accurate component matching, narrow tolerances, and accurate setup. Nevertheless, it has been success-

fully used in amateur radio equipment, mainly in the past when separate transmitters and receivers were used. Today, transceivers are mainly used, and the phasing method is not used because a filter is still needed for the receiver section. Although other methods exist, undoubtedly most SSB generation will be done for awhile using the filter method. SSB crystal filters have decreased somewhat in price because of manufacturing and design improvements, as well as increasing market demand, keeping the filter method the most popular approach. This could change as digital signal processing techniques may replace the filter as the most common method of SSB generation in the future.

Reception of SSB signals generally follows the reverse of the generation process. A look at the spectrum of a voice SSB signal shows that it is simply the input audio input spectrum shifted up into the RF region. For example, consider a 10.000-MHz voice frequency SSB signal. If the USB mode is used, the transmitter produces a signal having frequency components of 10.0003–10.0030 MHz, or simply 300–3000 Hz (0.3–3 kHz) shifted arithmetically higher in frequency by 10 MHz. To receive this signal, we must simply shift it back down to the audio region. For LSB, the transmitted spectrum is also inverted, the higher voice frequency components producing lower transmitter frequency components. A simple mixer (in this application, commonly called a *product detector*—same mixer circuit, different name) can be used for this function. A receiver can be built in which an antenna is connected to a mixer that is fed with an LO. If the LO is exactly the same frequency as the suppressed carrier of the input SSB signal from the antenna, the product detector output is the original audio that modulated the SSB transmitter. This type of detector—when used with an antenna and a suitable audio amplifier—makes up a receiver commonly called a *direct conversion receiver*. Useful for SSB and CW (Morse code) reception, this scheme is popular for low-cost ham radio receiver construction and eliminates much RF circuitry. The LO must be stable and have good noise characteristics, and a low-noise audio amplifier is necessary, but sensitivities around 1 microvolt can be obtained. The bandwidth is that of the audio amplifier. Disadvantages of this receiver are a lack of sideband selection, poor RF selectivity, a lack of AM reception capability because of LO beating with the AM carrier, and susceptibility to RF overload because generally no AGC is used; however, this receiver provides a lot of performance with little circuitry and is superior to and easier to use than a regenerative receiver for SSB and CW reception.

The carrier must be reinserted at the detector within a few hertz of the original carrier; otherwise, the frequency of the audio output is shifted from the original by an amount equal to this difference. For speech 50 Hz is acceptable, but for quality 10 Hz is desirable, and for music or where frequencies are critical, 1 Hz may be needed. In order to assist in this process, a pilot carrier may be transmitted. This is a residual sample of the original carrier sent at a known level (i.e., –30 or –40 dB down so that it is not noticeable). A phase locked loop (PLL) at the receiver is used to lock onto this pilot carrier, ensuring accurate tuning. Modern SSB equipment used by amateur radio operators can easily hold frequency within 10 Hz, so this is not often done. If the reinserted carrier is way off, the SSB signal will sound like gibberish, which is often called the “Donald Duck” sound. If the carrier is way off (by a few kHz) and is placed on the opposite side of the signal, the recovered audio may actually be spectrally inverted, so that original low speech frequencies (300–400 Hz) are now at the high end of the audio band, near 3000 Hz, and the original audio components at the 3000 Hz end of the audio spectrum are now shifted down to the 300-Hz region. This is called *inverted speech*, and this concept is used elsewhere to scramble

an audio signal for privacy or security purposes. In practice, this is done with special circuitry designed for this purpose.

Other than the requirements for an accurate and stable LO frequency and a product detector, an SSB receiver is generally a standard superheterodyne receiver with high RF performance in areas of dynamic range, noise floor, and stability, with special AGC circuitry, because there is no carrier for AGC reference as exists in an AM receiver. A SSB receiver usually has a separate envelope or synchronous detector for AM reception anyway and has switchable AGC for each reception mode. In a transceiver system, often the same circuitry run “backwards” is used for SSB generation and detection. This is called *bilateral circuitry* and is not discussed here. The interested reader is referred to books such as the *ARRL Radio Amateurs Handbook* or the *RSGB Handbook* for details on this type of circuitry. This discussion of SSB techniques has necessarily been brief. Entire books have been written on SSB, but this topic is not the focus of this book. Our intent in this chapter has been to familiarize the reader with SSB in order to understand the following chapter on SSB generator circuits.

21. Basic Single Sideband Generator/Exciter Unit

Although a complete single sideband (SSB) transmitter can be complex, the “heart” of one is not too bad to construct and can be an educational project. In addition, some of the principles and circuits employed in other projects in this book can be used to extend this basic unit into a small SSB transmitter. We concentrate on that circuitry used to generate the SSB signal. Much of the remaining circuitry is straightforward, albeit it might require care in planning, design, and construction.

A SSB signal can be generated in several ways, but for the experimenter with limited test equipment, the easiest way is the filter method discussed in the previous chapter. A complete prepackaged SSB filter can be obtained from several manufacturers, or a lattice filter can be constructed from commonly available microprocessor crystals. This route is undoubtedly the cheapest way to go but requires some experimentation because the particular crystals that you purchase or have on hand may differ somewhat from those we used in our prototype. This is to be expected because the crystals are being used in a somewhat different application from what they were intended for; however, the money saved is considerable because a commercial prepackaged filter may run \$30 or more in small quantities, whereas microprocessor crystals can often be bought for \$1 or less, and only five are needed.

The balanced modulator can be made from prepackaged diode ring mixers. These have excellent performance and relative freedom from adjustment, provided they are not overdriven with excessive signal levels. The prepackaged mixer circumvents the necessity of building a balanced mixer and eliminates several parts. Alternately, a balanced modulator IC, such as the MC1496, can be used, as was used in the FM stereo transmitters described elsewhere in this book. This approach needs more components and is probably not much cheaper than the diode ring mixers, considering the extra parts and adjustments. The MC1496 is better suited to lower-frequency applications that run at relatively large signal, medium- to high-impedance (1000 ohms or more) levels. The diode ring mixer is better suited to higher-frequency, low-impedance applications, and they work well in 50-ohm RF applications. Low-cost units are available that cover the 0.5–500 MHz frequency range. They have three ports: RF (input), IF (output), and LO (local oscillator). The IF port on these units generally functions down to DC, and in addition, these mixers are bilateral (signal direction can be reversed) and are inherently balanced, which means that a signal inputted to a given port does not appear at any other port. This allows for easier design. For example, in a receiver or transmitter application, the LO signal or the RF input signal frequency does not appear in the mixer output, only the desired sum and difference mixer output frequencies. This greatly simplifies filtering.

The price paid for this performance is that only relatively low-level signals can be handled, and considerable LO injection power is required. The low-cost mixers used in this application (Minicircuits SBL-1) require +7 dBm LO injection power, and for

best performance a pad of 3–6 dB is used on the LO input, so about 10 milliwatts (mW) of oscillator signal is needed to properly drive these mixers. This is 0.7–1 volt RMS into 50 ohms. Other mixers that handle much larger signal levels are available, but some of these require 50–200 mW LO drive. These mixers are used in critical applications needing high dynamic range. Depending on the permissible level of performance with respect to intermodulation products, the input signal level should be limited to a maximum of one-tenth (–10 dB) of the LO power, and preferably a maximum of –15 to –20 dB below the LO power level. For the SBL-1 in this application, with an LO drive signal of 0.5 volts RMS (+7 dBm), this means about 50 mV maximum input. There is a theoretical 6 dB conversion loss (SSB), plus about 1 dB device loss, so a total conversion loss of 7 dB can be expected. With a maximum 50-mV RMS input, about 20-mV RMS output can be expected. Exceeding these levels results in higher levels of spurious product generation; however, in some cases this may be acceptable, depending on the application. We mention this issue to explain why the circuitry to be discussed operates at such seemingly low signal levels.

A block diagram of the circuit to be discussed appears in Figure 21-1. An audio signal of about 20 mV RMS from a high-impedance source (microphone, etc.) is applied to an audio amplifier. Because only about 50 mV RMS is needed to drive the modulator, a voltage gain of 2.5 is needed, but the drive impedance of the audio input of the balanced mixer is low (less than 50 ohms). This signal is fed to the IF input of the mixer, the only port that handles audio frequency signals. A crystal oscillator at the carrier frequency (11.0592 MHz nominally) generates an RF drive signal. A buffer amplifier amplifies this to a 20-mW level (1 volt into 50 ohms). This drive signal is fed to a 3 dB attenuator network with a 50-ohm impedance. This network helps to stabilize the source impedance of the carrier signal source, so a good 50-ohm source is provided. The signal is fed to the LO port.

At the RF port, the audio and RF carrier are canceled, but a signal consisting of the sum and difference frequencies appears. These are the lower and upper sidebands, respectively. The output level of each sideband is about 20 mV RMS. This is fed through an impedance matching network to the filter. The filter has a 330-ohm impedance, and therefore a matching network is needed. The impedance stepup from 50–330 ohms implies a voltage stepup of 2.56, so the filter receives about

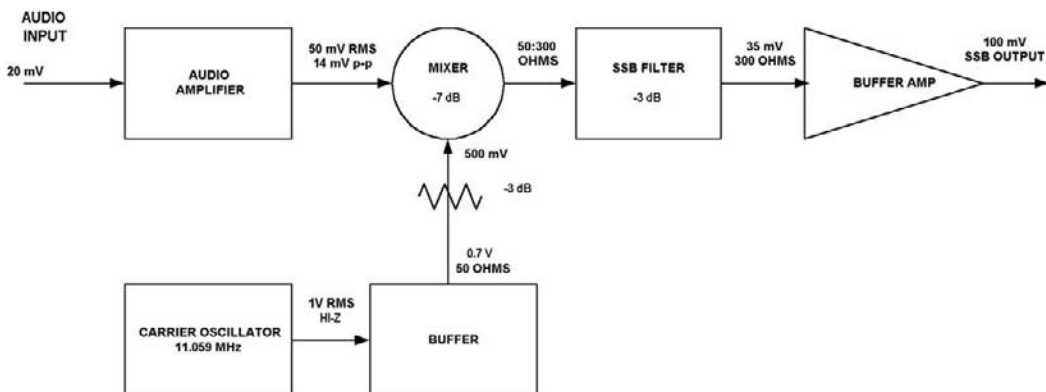

Figure 21-1
Block Diagram of a Single Sideband (SSB) Generator

50 mV RMS per sideband. The crystal filter has a loss of about 3 dB, so 35 mV appears at the output. This is the lower sideband only, the upper sideband being rejected by the filter. A buffer amplifier is used so as not to load the filter, which is terminated by a 330-ohm resistor. About 100 mV of signal into 50 ohms is obtained from the buffer. This is enough to drive another mixer, allowing for a 3–6 dB attenuator at the input of the next mixer (not shown). This mixer can be used to mix the signal with another LO signal for conversion to another frequency and/or sideband inversion to get an upper sideband signal (USB).

Referring to Figure 21-2, the schematic of the SSB generator, operation is as follows: Audio input is fed between R1 and ground. Q1 and Q2 make up a feedback amplifier with a nominal gain of approximately 50. R2, R3, R4, R5, and R6 are biasing and gain setting resistors. The ratio of R3 to (R1 + source impedance) determines audio gain. R5 and R6 form a voltage divider and produce a 30-ohm source impedance for driving mixer M1. The input impedance of M1 to audio is around 50 ohms, so about 50 mV RMS of audio appears at the junction of R5, R6, and coupling capacitor C3. R7 and C2 form a bypass and decoupling network for the audio stage. Approximately 6 volts DC appears across C2.

FET Q3 and crystal X1, together with trimmer C4, R9, R8, L1, C5, and C6 form a Pierce crystal oscillator circuit. X1 must oscillate at a frequency on the slope of the filter for maximum sideband suppression, and C4 sets the exact frequency needed, which is determined by the filter response curve. C5 and C6 feed a sample of oscillator signal to buffer amplifier Q4. L1 and R8 couple DC bias to the FET, and L1 raises the impedance of the DC feed circuit so as not to cause RF loading. Buffer Q4 is biased by R10 and R11, and an unbypassed emitter resistor R12 gives some degenerative feedback, keeping the Q4 buffer both RF stable and low in distortion. T1 is a

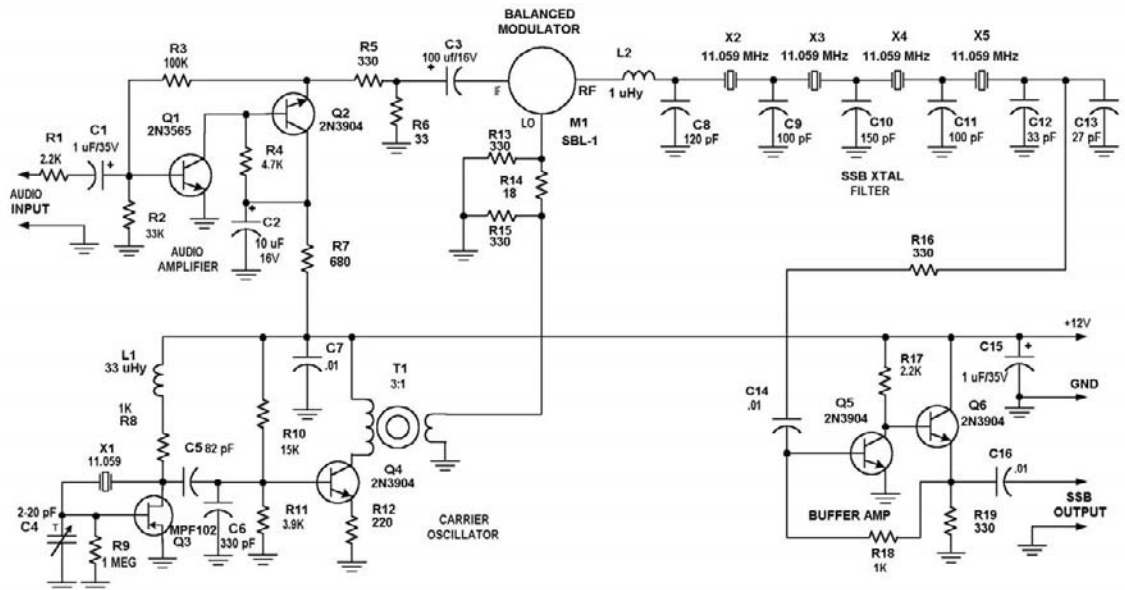

Figure 21-2 Schematic of a Single Sideband (SSB) Generator

3:1 stepdown toroidal RF transformer to match the 50-ohm mixer to the higher collector impedance of Q4. About 1 volt of RF signal is available from the secondary of T1. R13, R14, and R15 make up a 3 dB attenuator to ensure a good 50-ohm source impedance of the oscillator circuit as seen by mixer M1.

The SSB filter is made up of four microprocessor crystals. A frequency of 11.059 MHz was chosen based on a good choice of SSB generator frequency for conversion to the 10-meter amateur band (28–29.7 MHz) and available stock microprocessor crystals. This permits use of an LO in the 39–40 MHz range to provide mixer injection and also, because the LO is above the generator frequency, sideband inversion occurs in mixing, yielding a 28–29 MHz USB signal, which is required on 10 meters. This LO frequency is readily produced with a PLL chip such as the Motorola MC145XXX series of PLL chips. The “oddball” 11.059-MHz frequency is no problem because this can easily be compensated for in the software used to serially program the PLL synthesizer microcontroller. With proper programming, the desired output frequency of 28.000–29.000 in 100-Hz steps is produced. L2 and C8 form a matching network to transform 50 ohms to 330 ohms.

C8 would normally be 60 pf, but an extra 60 pf capacitance is bundled into the value of C8 because the filter needs a 60 pf capacitor to ground at this point, making a total of 120 pf. X2 through X5 are 11.059-MHz microprocessor crystals. C9, C10, C11, C12, and C13 determine filter response and were determined with some trial and error because the crystals we used were of unknown characteristics. Very likely, these values will be different if different makes of crystals are used. Filter insertion loss was found to be 3–4 dB, which is reasonable for a filter of this type. The filter has a steeper skirt on the high side, so LSB operation was more appropriate. This characteristic is inherent in this type of homemade filter. Bandwidth was 3000 Hz, which is just right for SSB use. (See Figure 21-3 for filter response curve obtained.) If desired, a commercially made filter of another frequency could be substituted, with appropriate circuit value changes as needed to accommodate the new frequency.

The filter output is fed to a buffer amplifier Q5-Q6. This provides proper termination of the filter and makes up for the loss in the mixer and filter. R16 provides termination and determines the gain of buffer amplifier Q5-Q6. R17, R18, and R19 bias Q5 and Q6 and determine gain, which was set at 10 dB voltage gain. About 100 mV of LSB signal is available, and the output impedance is low. C14 and C16 provide DC blocking. C15 is a supply bypass capacitor. The output can be fed into a second mixer, preferably through a 3 dB attenuator pad similar to R13, R14, and R15, in much the same way. This mixer can provide conversion to another frequency and/or sideband inversion as required.

Alignment is simple. Connect an audio generator set for 2000 Hz to the audio input. Use no more than a 10-mV level. Note the output of the buffer amplifier at C16. Now change the audio frequency to 400 Hz. Adjust C4 so that the output is –6 dB with respect to the output the 2000-Hz tone produced (about one-half amplitude). Now, varying the audio frequency, plot the RF output versus the audio frequency. The object is a sharp rise above 400 Hz, leveling off and flat within 2 dB or better between about 700–3000 Hz, and dropping off rapidly beyond 3500 Hz. The filter network largely determines this response. Note that the RF envelope should be a pure carrier with little or no modulation ripple evident on the RF envelope, if everything is working right. This is not perfect below 700 Hz but should be good between 700–3500 Hz audio input. Excessive ripple indicates nonlinearity, excessive audio drive, or poor filter performance.

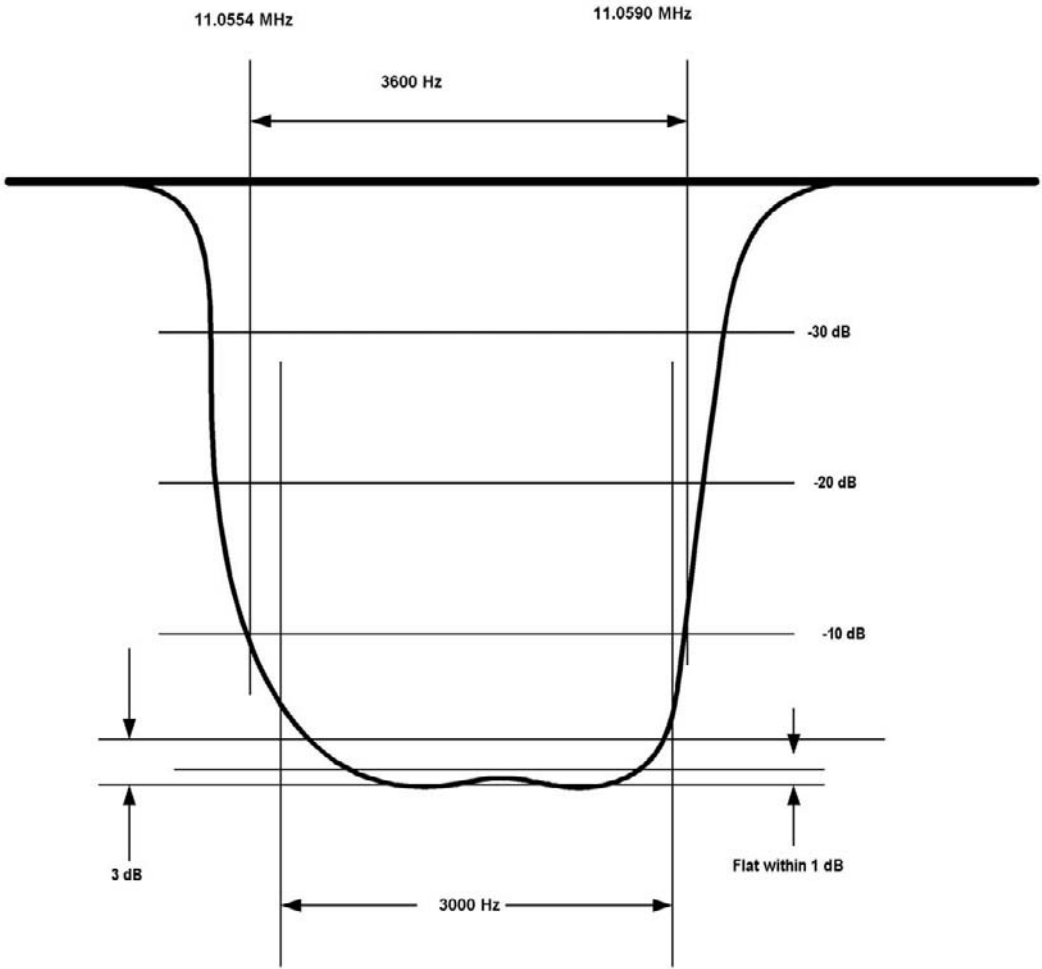

Figure 21-3
Filter Response of the Single Sideband (SSB) Generator

This Page Intentionally Left Blank

22. 1-Watt CW Transmitter for the 1750-Meter “LOWFER” Band

A little-known fact is that it is perfectly legal under Part 15 of the FCC rules and regulations to place an unlicensed 1-watt transmitter on the air if the transmitter operates into a maximum 50-foot antenna, in the frequency range 160–190 kHz. This range of frequencies, in the long-wave range, is characterized by dependable ground-wave propagation, especially over seawater. In Europe, this range is part of the long-wave AM broadcast band, which is generally 150–285 kHz. In this range, AM broadcasts can be reliably received over several hundred miles in daytime. This range is also useful in mountainous territory where VHF signals such as those used for FM broadcasts are blocked by mountains and terrain. In the United States, this range is allocated to fixed services, but there are few signals in this range at the time of this writing (spring 2000). In fact, the main signals that are detectable in the northeastern part of the United States (New York/New England) are AM broadcast signals that originate in Europe. These signals are sometimes surprisingly strong, especially in winter, coming through as early as 3 P.M. during winter afternoons. During late spring and summer months, static levels caused by thunderstorm activity are high. The relatively short nights at this time of year in the higher latitudes (50–60 degrees North) do not favor low-frequency radio propagation over the North Atlantic Ocean. As a result, these signals are not usually heard during the summer months, but the main sources of interference in this frequency range are manmade. Triac devices, switching power supplies used in computers, TV sets, fluorescent lighting, and power line noise are all sources of interference in this region of the spectrum.

Several hobbyists have set up stations in this band and operate continuously running beacons that transmit a Morse code identifier. Ranges obtained are generally 10 to a few hundred miles. By using weak-signal techniques, such as very narrowband receivers and phase coherent signals, as well as digital methods in which very narrow effective bandwidths of 1 Hz or less can be realized, ranges of several hundred miles have been obtained. By careful tuning and patience, it is often possible to hear one or more of these beacons on a reasonably good receiver covering this range (some of the newer shortwave receivers do).

This chapter describes a 1-watt transmitter that can be used on this band. Most of the operation in this band has been and still tends to be in the upper 10-kHz segment, from 180–190 kHz. There is probably less interference in this range, and antenna efficiencies are slightly better, although some operators prefer to use the lower end of the band. There are more broadcast signals in the lower part of the band than in the upper; however, recently (1999) a new station in Reykjavik, Iceland, which is used for domestic broadcasting, has been putting in a fairly good 189-kHz signal into eastern Canada and the northeastern United States, to the dismay of some LF hobbyists. At the time of this writing, a petition for an amateur LF allocation has been filed with the FCC, both for the 160–190 kHz band and at 135–137 kHz, to

match the current LF amateur allocation in Europe. If this allocation is granted, use of this band by amateurs may change current operating practices. Undoubtedly, larger antennas and/or more transmitter power will be permitted. We will have to wait and see because it may take a few years to change.

It is important on this band to accurately know the transmitter frequency and to maintain a good degree of stability. The approach used here is to generate a signal in the HF range, around 8–9.5 MHz, and then divide the frequency by 50 to produce output in the 160–190 kHz range. The HF signal is best generated with a PLL to obtain good frequency stability. A Motorola MC145151-2 chip used in other projects in this book is employed. Although the chip is capable of operating at twice this frequency, the maximum divide ratio obtainable is 16383. If we settle for 1-kHz synthesizer frequency steps (resolution), the output frequency resolution is 20 Hz because we are dividing by 50. To divide by 100 and get 10-Hz resolution would require a divide ratio of 16000 to 19000, which this chip will not support. We also could use a divide-by-64 ratio, but this will give 15.625-Hz resolution (not convenient for us humans), so the 20-Hz resolution will be used. A pair of 7490 TTL logic chips is used to obtain the division by 50. The first chip is used as a divide by 5. The second chip is configured to divide by 10. This chip is configured to first divide by 5 then divide by 2. This gives a simple squarewave output, which is perfect for driving the power amplifier circuitry, and the symmetrical squarewave has a lower even harmonic content than the asymmetrical pulse train output that would result from using first a divide by 2 into the divide by 5 portion of the chip. Pins 2 and 3 of IC4 are normally held low but will reset the counter to 0 and hold it there when high. This feature is used to key the transmitter via an external telegraph key or other keyer. The squarewave from the chip is fed to a 2N3904 predriver. The power amplifier is an MJE180, which produces 1-watt RF output, including any losses in the output filter network. The CW signal, as heard on a receiver, sounds crisp and clean, with no objectionable keying clicks or chirps evident. Some of the circuitry is similar to that used in the PLL AM transmitter described in this book.

The circuit of the PLL synthesizer shown in Figure 22-1 operates as follows: Q5, an MPF102 FET, is configured as an oscillator whose frequency is determined by T1 and the capacity of varactor diode D2, trimmer C10, and the circuit stray and FET input capacitance. This oscillator operates in the 8.0–9.5 MHz range. R15 provides DC bias for Q5. C9 RF grounds the anode of D2, which is fed a variable DC bias from R13 and R14. Depending on this DC bias and the setting of C10, this is anywhere from 8–9.5 MHz. Oscillator signal is taken from the source of Q5. Part of this signal is passed to amplifier stage Q2. R7 feeds signal to Q2, which is connected as a wideband feedback stage with R5 and R6 for feedback and bias. A signal large enough to drive the input of the divide by 50 IC chain IC3 and IC4 appears at the collector of Q2. The variable divider section of PLL synthesizer chip IC1 is programmable via DIP switch S1 sections 1 through 12 to divide between 8000 and 9500. This is equal to the desired output frequency times 50. For example, if a frequency of 180 kHz is desired, then the divide ratio will be programmed as 9000 via the setting of S1. The internal variable divider will produce a signal to be fed to the phase detector at the transmitter frequency divided by 9000 because we have a division of 9000 times from the programmable divider.

Meanwhile, the phase detector is fed a 1-kHz reference signal derived from an internal reference oscillator and divider, which uses external components R4, C2, X1 (8192-kHz crystal), and trimmer C1. These parts determine the oscillator frequency. C1 is used to set the frequency exactly to 8192 kHz. An internal divider

1-Watt CW Transmitter for the 1750-Meter "LOWFER" Band

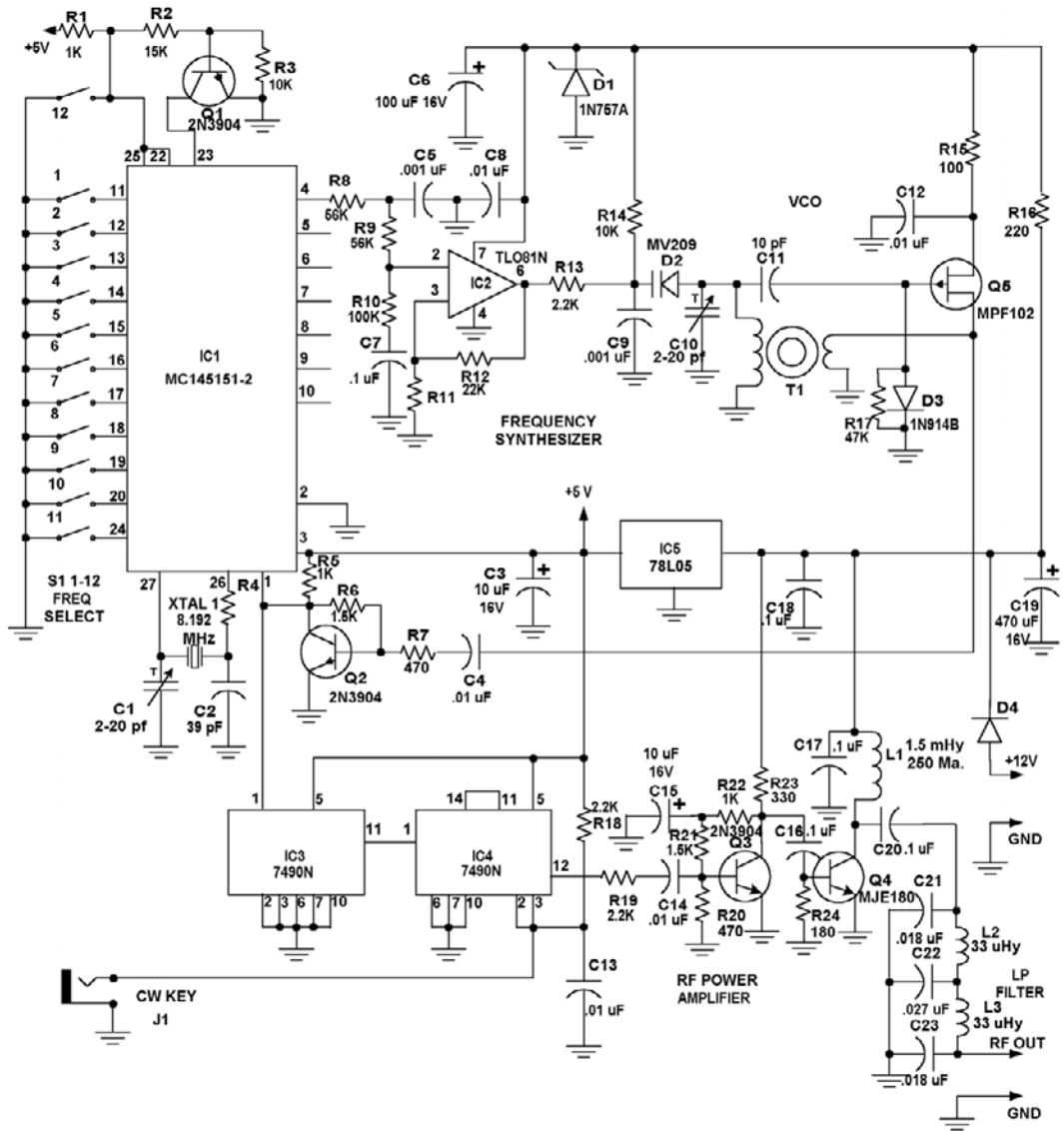

Figure 22-1
Schematic of a Synthesized 1W 160-190 kHz (1750 Meter Band) CW Transmitter

divides this by 8192 and produces the 1-kHz reference used by the phase detector inside the IC. The output frequency accuracy depends on having an exact 1.000 kHz, which in turn needs an exact 8192-kHz crystal oscillator frequency. The internal phase detector generates a voltage, which depends on the relative phase difference between the reference and variable divider output waveforms. For example, suppose the divider output starts to lag the reference. This implies that the divider, and hence the VCO frequency, is tending to go lower. In this case, the phase detector produces positive-going pulses and feeds these to the sample and hold network R8, C5, R9, R10, and C7. C7 is charged to a higher DC voltage. IC2, a TLO81 FET op-amp, acts

as a buffer amplifier for the PLL phase detector and provides a very high impedance for the sample and hold circuit, minimizing 1-kHz reference frequency sidebands and allowing smaller capacitors to be used in the compensation network. The high-impedance FET amplifier consisting of IC2, R11, R12, and R13 produces a positive-going output, which is fed to D2 via R13 and R14, causing the oscillator frequency to increase. The opposite happens if the VCO drifts higher, causing the divider output to lead the reference. Then D2 is biased with a negative-going change in DC bias and causes the VCO to lower its frequency. In this way, the VCO frequency is locked to the reference frequency and will not drift. It will be exactly equal, in kHz, to the programmed divide ratio divided by 50. In our case, we have programmed 9000 so that the output frequency will be $9000 \text{ kHz} \div 50$, or 180.00 kHz. This frequency is the final desired 180.00-kHz transmitter output.

The PLL output signal is 50 times the desired transmit frequency. This signal is present at the output of Q2, being a sample of the VCO voltage amplified to TTL-compatible levels. This point is also connected to the input of a frequency divider chain consisting of a pair of 7490 TTL ICs. These ICs have a divide-by-2 section and a divide-by-5 section and produce a BCD count at their four output pins. We use only the divide-by-5 section (input pin 1) of IC3, the first counter; the divide by 2 is not needed. The output of IC3 at pin 11 is a pulse train at one-fifth the VCO frequency and is in the frequency range 1600–1900 kHz, in 200-Hz increments, because the PLL resolution is 1 kHz. This output is fed to the input (pin 1) of IC4, another 7490 counter. The divide-by-5 output is at pin 11 and is in the range of 320–380 kHz. This pulse train is fed into the divide-by-2 section of IC4 (pin 14), and a symmetrical squarewave at the transmitter output frequency appears at pin 12 of IC4. This is fed to the RF amplifier section Q3 and Q4 and results in the transmitter producing RF output. IC4 is also used for keying the transmitter RF output as follows: pins 2 or 3 of IC4 reset and hold the count state of IC4 at 0 when either or both are at a logical high. These pins are tied to +5 volts via R18 and connected to keying jack J1. A telegraph keyer, identifier circuit, or other keyer connected to J1 drives pins 2 and 3 of IC4 to ground when the keying device has a low impedance to ground, resulting in output from the divider chain at pin 12 IC4. When the keyer shows an open or high impedance, pins 2 and 3 are pulled high by R18, causing the count output of IC4 to be 0, and no RF energy is produced by the transmitter.

The transmitter RF power amplifier section consists of driver Q3 and output power amplifier Q4. R20, R21, R22, and R23 bias Q3 while C15 prevents RF feedback through the bias network. R19 and C14 couple the squarewave signal from IC4 to driver amplifier Q3, a 2N3904. C16 couples drive from Q3 to the base of Q4. R24 is a base bias resistor for Q4. RF choke L1 feeds DC to Q4, and C20 couples RF energy to RF output network C21, L2, C22, L3, and C23. This network provides impedance matching and suppresses harmonics. Efficiency is good, and no heatsink is needed for Q4. The transmitter RF output from J2 appears as a pure sinewave on an oscilloscope. The transmitter is designed for a 50-ohm load, and the antenna should present this impedance to the transmitter. RF output is approximately 1 watt. The entire transmitter draws approximately 130 mA (key down full output conditions) at 12 volts DC supply voltage. Modulation is continuous wave (CW), and voice modulation is not supported.

If binary phase-shifting keying (BPSK) operation is desired, a modulator may be used to reverse the phase of the CW signal, and this modulator may be fed with the TTL keying waveform. Either a passive diode mixer or an active type such as an LM1496N may be used. It is also possible to use an NAND or XOR logic gate IC

arrangement to do this, which might be the simplest and cheapest approach. This decision is left to the experimenter. Because this project is specialized, with limited mass-market demand, no PC board was designed for this project, and it was built "ugly bug" style. Basically, most of the circuit is similar to the AM88 project discussed in Chapter 5, and the PC board for this project can be used to build the synthesizer, VCO, and RF PA/output filter. The divider section IC3 and IC4 was built on perfboard in our prototype and mounted to the AM88 PC board via its leads.

Tuneup of this transmitter requires only a few steps. A 12-volt supply, which must provide clean DC with little ripple and be able to deliver 250–300 mA, is needed to power the transmitter. Beware, however, that most wall-type transformers are not good enough. Use batteries if you are in doubt—eight alkaline AA, or C or D cells connected in series, will handle the transmitter power requirements. Connect a 50-ohm load (use two 100-ohm 1-watt resistors connected in parallel) to the RF output jack. Set the DIP switches S1-1 to S1-12 for 190.000-kHz output. Set trimmer C10 (VCO trimmer) to maximum capacitance. With a VOM on pin 6 of the op-amp IC2, you should read close to 8.5 volts. While watching this voltage, adjust C10 until this voltage drops to 7.5 volts. Next, connect an accurate frequency counter across the 50-ohm load. (Use a 10:1 probe if one is available because 7 volts of RF will be present here, which may overload some counters.) Connect a key to J1. While depressing the key to key the transmitter, adjust C1 for exactly 190.0000 kHz. Use a 10-second gating time if the frequency counter will support this, for the best accuracy. Try to set the transmitter frequency to ± 1 Hz if possible. Note that the two 100-ohm resistors used as a load will become warm. This reaction indicates the presence of adequate RF output and that everything is working correctly. A 6-volt dial lamp, such as a type 47, rated 6.3 volts at 0.15 amperes, is close enough to 50 ohms when lit and should light to full brilliance when connected to the RF output jack. This lamp provides a good visual proof of transmitter output.

This completes initial tuneup. You will need a good antenna to use this transmitter on the air. Consult a good text on antennas to get educated on this subject if necessary, and check out the Long Wave Club of America (LWCA) Website at www.LWCA.org for more information on antennas and LF operation in general.

This Page Intentionally Left Blank

23. Simple CW Identifier

A continuous wave (CW) identifier (ID) has several uses, from automatic identification of repeaters, transmitters, and beacons, to performing repetitive CW chores such as calling CQ. An identifier is a device generating a preprogrammed message of some kind, generally a call sign and possibly additional data such as the geographic location or status of the transmitter with which it is used. An identifier can be set up to generate a message either on command or continuously, depending on the application. There are several approaches to the circuitry, which may involve anything from simple mechanical keyers, a tape-recorded audio tone driving a keying relay, or a purely digital approach that generates the required keying waveform from a programmed memory of some sort. A microprocessor can be programmed to generate the desired message, but if no other control, monitoring, or data transmission features are needed, it is easier to simply read out a message stored in a memory such as an EPROM.

We had a requirement for a simple ID circuit for an experimental beacon transmitter system currently under construction. The generation of a keying waveform that would be continuously running and that would include call sign and grid square, together with a short carrier for tuning purposes, was needed. In addition, simplicity and low cost was desired. A circuit evolved, using a 555 timer running at the baud rate, feeding a counter that addresses a CMOS EPROM. The message can be programmed into the EPROM with an EPROM programmer. Our programmer runs off the laboratory PC, and its DOS-based software makes the programming simple. It connects to a second parallel port (LPT2). If you do not have a programmer and/or a PC, the EPROM can be manually programmed via a simple circuit consisting of a pulse generator and a few SPDT switches. See the EPROM manufacturer's data sheets for the exact procedure. In many cases, these instructions can be found on the Internet and downloaded free.

EPROMs have become cheap and easily available. Even a long-winded ID sequence will fit into the smallest of them. The smallest commonly available one today is the 2716, which is a 16K-bit unit. The memory is arranged in bytes, so there are 2048 bytes (8 bits); however, there seems to be no correlation between price and size, and the 2764 is usually cheaper because it is common in surplus, so we used the CMOS version, the 27C64. These parts are fairly common. If you use a surplus part, make sure it is erased clean (all bits logical 1) before using it. You can use an EPROM eraser or a strong UV lamp to do this, or try leaving the EPROM with its window uncovered, in strong sunlight, for a few days. Otherwise, use a new part. The desired code is programmed into the EPROM one byte (8 bits) at a time.

We used a logic high (an erased, "clean" EPROM has all bits at logic high) as a space and a logic low as a mark; however, a little thought can save some circuitry and programming effort. Normally, each bit is addressed sequentially. This requires

circuitry at the EPROM output (which is 8 lines per address) to select each bit 0 through 7 in sequence; however, we have 8192 addresses, so why not use only one bit per byte and ignore the rest? This saves circuitry and simplifies programming. One other bit can be used to signify the end of the message and to reset the counter once the last needed address is reached. This approach is wasteful in terms of memory utilization, but we have far more than we need anyway. We used the #4 bit as the programmed output and bit 0 as a control bit. When bit 0, normally the same as bit 4, is different from bit 4, this condition can be employed as an end-of-message marker and used to reset the counter back to 0, starting the cycle over. Of course, any other two bits can be used as well.

Morse characters are formed from dots and dashes. Generally, a dot is considered as a unit length. Then a dash is three but may be up to five dots in length, and dots and dashes are separated by the length of a dot. Letters are spaced generally three to five dots, or the length of a dash. Words are spaced somewhat farther apart, five dots or so. These spacing rules are a matter of individual preference, but longer dashes are somewhat easier to read at very slow (less than 5 words per minute) CW speeds because the dots may be made shorter for a given CW speed. This method is also somewhat more “comfortable” to read and avoids the dots being at first mistaken for dashes. Wider spacing between individual letters with correspondingly faster transmission speeds for individual letters is sometimes used. This makes for better copy by CW operators who are used to faster speeds. (When you are used to normal 18–25 words per minute QSOs, 5 words per minute can be a bit tedious to copy.) We found that a ratio of 3:1 sounded best at the 10 words per minute speed intended and adopted a spacing of one dot between dots and dashes, and three dots (one dash) between letters.

The EPROM is programmed sequentially depending on the desired message. A given address location is programmed all ones (FFh), where the quantity in the brackets is the hexadecimal number programmed at that address, or all zeroes (00h). For those having to rig up a simple EPROM programming circuit, this makes life easier because all locations are the same logic level, reducing the chances of error. If you have ever manually programmed an EPROM, you will appreciate this fact. A single mistake in programming usually means erasing all data and starting over. In accordance with Murphy’s law, this generally seems to happen when you are three-quarters done or more, or have manually entered a few hundred data bytes. We strongly suggest using an EPROM programmer that operates with a PC if at all possible if you are going to program a long message; however, for a short ID, such as your call letters, you can get by with a manual programmer. The only location where there is any difference is the last one, which is used to signify the end of the message. In this location, an F0h is programmed. This condition is sensed by the logic and used to reset the counter that addresses the EPROM.

Circuit Operation

Referring to Figure 23-1, IC1 is configured as a free-running oscillator that has a frequency range of 4.5–13 Hz. The period of this waveform, which is determined by the total resistance of R2 plus the resistance of speed control pot R1, and capacitor C1, determines the CW speed. Assuming that an average Morse letter plus the space between letters has 10 dot periods, this means 27–81 letters per minute, or roughly 5–16 words per minute, assuming an average of five letters per word. This speed can

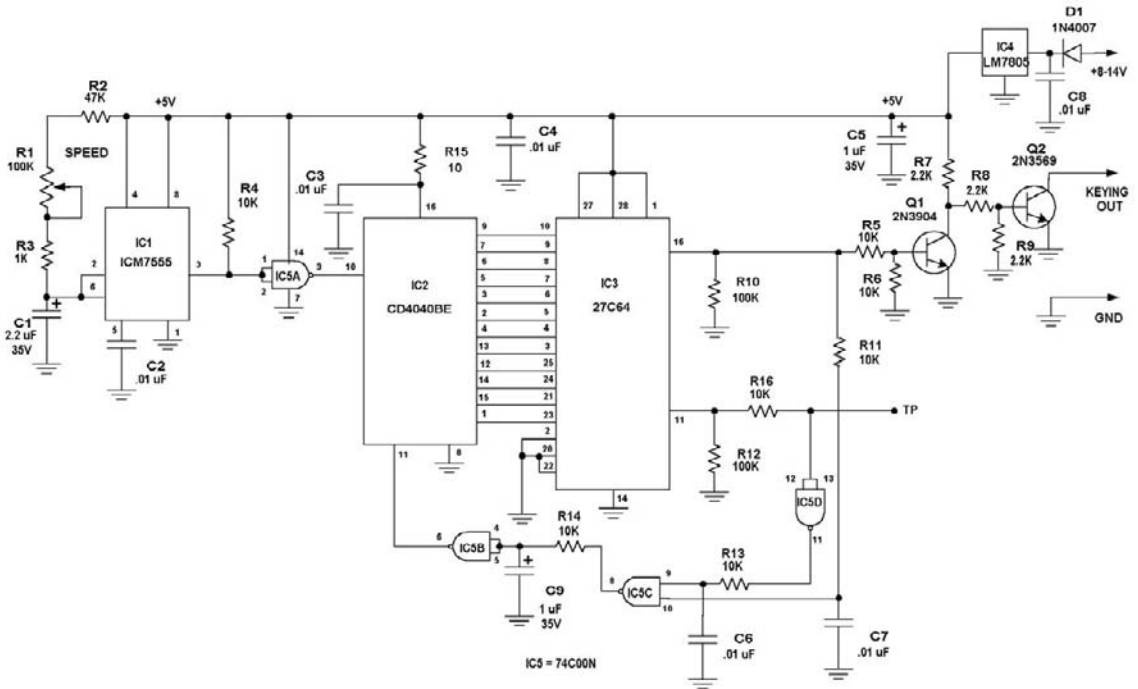

Figure 23-1
Schematic of a CW Identifier

be changed by changing the value of C1. R3 determines the discharge time of C1 and hence the width of the negative pulses appearing at pin 3 of IC1. This is not critical. R4 is used as a pullup resistor for the output of the timer IC connected to IC5. A section of IC5, a quad NAND, is used as an inverter to derive the positive-going CMOS level pulses to drive counter IC2. Counter IC2 has 12 output lines, and thus has 4096 states, and can address 4096 addresses (0000h to 0FFFh) of the EPROM IC3. Note that the counter drives address lines A0–A11 of IC3. The A12 line (pin 2 of IC3) is connected to ground. By the way, a switch or a jumper could be arranged to tie pin 2 of IC3 alternately high. This technique results in the addressing of locations 4096 to 8191 (1000h to 1FFFh) of IC3, and a second message could be programmed in this memory space. We did not bother with this option because it was not needed, but it should be mentioned in passing.

R15 and C3 provide power and bypassing to the V_{dd} pin 16 of IC2. R15 is probably unnecessary and was used as a jumper to avoid the necessity of a double-sided PC board layout. C4 and C5 provide bypassing for the 5-volt DC supply line. The data programmed into the EPROM appears at the eight outputs O0 through O7 of the EPROM, but we need only O4 and O0, the other output pins being disregarded. During the message, the outputs of O4 and O0 are identical. Typically, only the first 50–150 addresses are used, depending on message length, but all 4096 can be used if needed. At the average speed of one Morse letter per second, this allows up to around a 6–7 minute, 350–420 letter (80-word) message to be programmed.

Output from the EPROM is fed to Q1 via resistors R5 and R6. When the desired output is a space (key up), the EPROM is programmed with an FFh (all ones) and O4 and O0 is high. This biases on Q1, and the collector of Q1 is driven low, causing bias

current from collector load R7 to flow to ground. This removes bias fed via R8 and R9 to Q2, cutting Q2 off, and the collector of Q2, the keying transistor, is left floating. This corresponds to a keyup condition. If a mark (keydown) is desired, then a 00h programmed into the EPROM causes Q1 to cut off, allowing bias to flow to the base of Q2 from R8 and R9, turning on Q2. The collector of Q2 is forced to ground, producing a mark (keydown) condition.

Normally, O4 and O0 are identical. A sample of O0 is fed via R16 to a section c of IC5. IC5c is configured as an inverter. Its output is fed through RC filter R13 and C6 (to remove switching spikes) to one input of an NAND gate IC5d. A sample of O4 is fed through a similar filter R11 and C7 to the other input of NAND gate IC5d. Therefore, the output of IC5d is always high during the message because the two inputs must be both high for the output to go low. This high level is passed through RC network R14 and C9, which provides further despiking of the output of IC5d. The level out of the RC network is passed to IC5 section b, which is connected as an inverter. The output of the inverter is connected to the reset input of the counter IC2. IC2 will count with a low on pin 11 and reset to 0 with a high. Because the output of the inverter is low during the message interval, the counter counts up starting from 0, sequentially addressing the locations in the EPROM.

After the end of the message, the next EPROM address is programmed with F0h, so that O4 is high but O0 is low. This results in both inputs to IC5d being high, which forces its output (pin 8) low. This causes C9 to discharge through R14, eventually driving the input of IC5b low. Then, the output of IC5b goes high, producing a high level at pin 11 (reset) input of counter IC1, resetting it to 0. This starts the message cycle over. In addition, C9 holds the voltage at pins 4 and 5 of IC5b momentarily at ground on power up, providing a reset to counter IC2, initializing it at 0. This step ensures that the message starts at the beginning on power up. Also, if the counter was not initialized at 0, it may initialize at a count beyond the end of the message. It would have to then count up to 4095 and roll over before the message starts again. This could take several minutes and would be undesirable.

IC4, an LM7805, provides regulated +5 volts to the circuit and works with any input voltage of +8 volts or higher, up to +35 volts. It is not necessary to use such a large regulator, but plenty were on hand. A smaller 78L05 will suffice if the supply voltage is kept below about 18 volts. D1 provides polarity protection and “Murphy’s law insurance” and C5 and C8 ensure regulator stability. Current drain is about 7–9 mA.

If monostable operation (one ID cycle only rather than continuous operation) is present, a latch could be used between IC5d and the counter. The latch could be reset by the output of pin 8 IC5d and would hold counter IC2 in a set to 0 state until this latch was set by an external signal, starting the cycle again. IC5b could be one-half of this latch, and another gate would form the other half, or a discrete transistor could be used to save a gate. The signal would be derived from some outside source and would go low or high as necessary when an ID cycle was required. We did not incorporate this feature into the circuit because it would mean another IC package, and we did not need this feature. It is merely being mentioned for the benefit of those who might need monostable or one-shot operation because it is easily incorporated in the circuit. Also, an LED indicator driven by the output of the keying circuit can be added for a visual check of operation if desired. You can substitute an LED for R8 if desired. R7 could be changed to 1K to increase LED brightness. Nothing is critical here. Speed is not important, and we just need to ensure adequate drive to the keying transistor Q2 to handle about 50-mA load current. Make sure to observe LED

polarity. See Figure 23-2 for these modifications. You are on your own because we did not try them, but they should work fine.

Other applications of this circuit are possible. The use of this circuit as a timer with up to 4096 possible on-off segments is certainly feasible. The timing components in the 7555 circuit (R1, R2, R3, and C1) can be made large enough to produce clock speeds of as low as one cycle per several minutes (resistors of around 20 megohm and tantalum capacitors of 10 mfd or more). Do not use aluminum electrolytic capacitors because their leakage is too high for this application, and circuit operation will be erratic and unreliable. Large values permit a 4096-state cycle that may easily exceed one week. Almost any conceivable timing pattern within this time interval can be programmed, with 4096 segments possible. If no reset is used, the counter will simply roll over to 0 when a count of 4096 is reached, and then repeat the cycle. An optoisolator and triac arrangement could be used to control large AC loads at 120- or 240-volt line voltages. Similarly, the counter can be speeded up and used to generate serial digital waveforms for experiments or as an arbitrary waveform source.

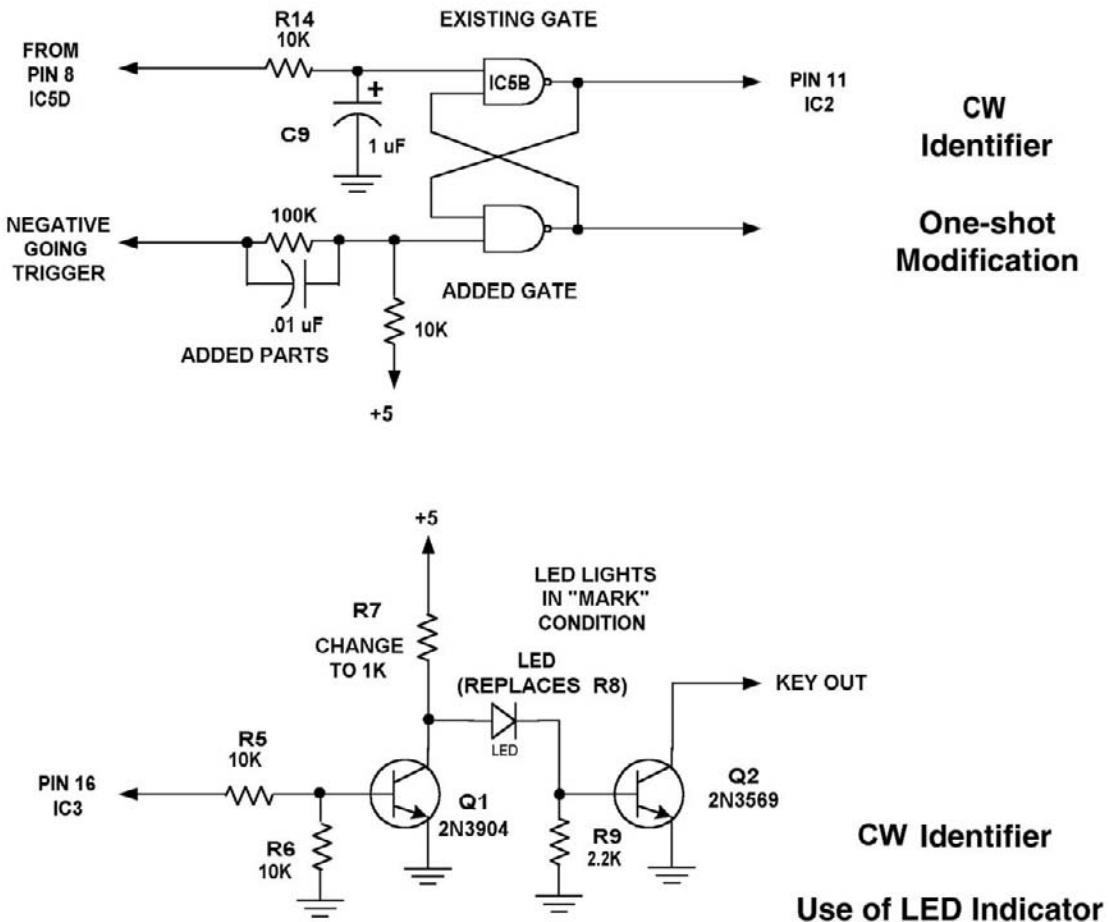

Figure 23-2
CW Identifier Modifications

Build Your Own Low-Power Transmitters: Projects for the Electronics Experimenter

Construction can be on the PC layout shown in Figures 23-3 and 23-4 or, if you prefer, you can use vectorboard and hard wire the connections, or use “ugly bug” or wire wrap. The highest frequencies present are in the low audio range, so almost any reasonable layout can be used. A diagram of the programming scheme is presented in Figure 23-5.

Figure 23-3
Printed Circuit
Board Component
Side Parts Layout
of the CW
Identifier

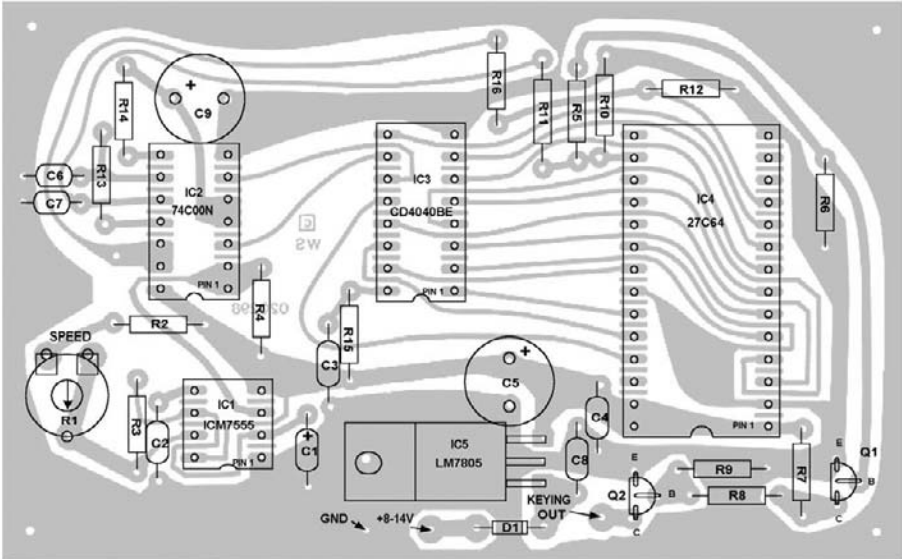
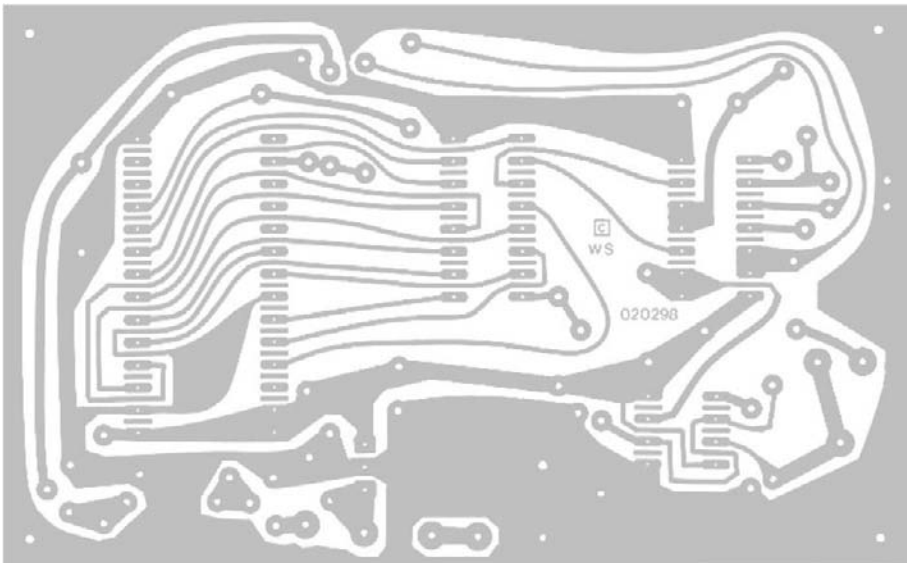

Figure 23-4
Printed Circuit
Board Solder Side
of the CW
Identifier



HEX	O7	O6	O5	O4	O3	O2	O1	O0
001D	X	X	X	X	X	X	X	X
001C	X	X	X	X	X	X	X	X
001B	X	X	X	X	X	X	X	X
001A	X	X	X	X	X	X	X	X
0019	X	X	X	X	X	X	X	X
0018	X	X	X	X	X	X	X	X
0017	X	X	X	X	X	X	X	X
0016	X	X	X	X	X	X	X	X
0014	X	X	X	X	X	X	X	X
0013	X	X	X	X	X	X	X	X
0012	X	X	X	X	X	X	X	X
0011	X	X	X	X	X	X	X	X
0010	X	X	X	X	X	X	X	X
000F	X	X	X	X	X	X	X	X
000E	X	X	X	X	X	X	X	X
000D	X	X	X	X	X	X	X	X
000C	X	X	X	X	X	X	X	X
000B	X	X	X	X	X	X	X	X
000A	X	X	X	X	X	X	X	X
0009	X	X	X	X	X	X	X	X
0008	X	X	X	X	X	X	X	X
0007	X	X	X	X	X	X	X	X
0006	X	X	X	X	X	X	X	X
0005	X	X	X	X	X	X	X	X
0004	X	X	X	X	X	X	X	X
0003	X	X	X	X	X	X	X	X
0002	X	X	X	X	X	X	X	X
0001	X	X	X	X	X	X	X	X
0000	X	X	X	X	X	X	X	X

- SPACE (LOGIC 0)
- MARK (LOGIC 1)
- ⊗ DONT CARE

EPROM PROGRAMMING

1) Only O0 and O4 are used

2) SPACE = Logic 1

MARK = Logic 0

X = DONT CARE

3) Message AB shown, O0 and O4 programmed as shown in memory pattern.

4) Counter reset requires O4 to be space, O0 to be a mark.

5) Leave first location as space to avoid longer cycle that will occur on first oscillator cycle after power up.



Parts List

Resistors 1/4W 5%		Capacitors	
R1	100 K pot	C1	2.2 uf 35V tantalum
R2	47K	C2, C3, C4	
R3	1K	C6, C7, C8	.01 disc GMV
R4, R5, R6, R11	10K	C5, C9	1 uf 35V electrolytic
R13, R14, R16			
R7, R8, R9	2.2K		
R10, R12	100K		
R15	10		

Build Your Own Low-Power Transmitters: Projects for the Electronics Experimenter

Semiconductors		Integrated Circuits	
D1	1N4007	IC1	ICM7555 CMOS timer
Q1	2N3904	IC2	CD4040 counter
Q2	2N3569	IC3	27C64 CMOS EPROM
Miscellaneous		IC4	74C00N quad NAND
1 ea	PC Board	IC5	LM7805 5V regulator
1 ea	4-40 BHMS		
1 ea	4-40 lockwasher		
1 ea	4-40 hex nut		

Part 15 AM Broadcast Applications

For most short-range applications, a 4-foot whip antenna in parallel with a 56-ohm terminating resistor may be connected to the transmitter RF output. A maximum field strength of $24,000/f$ (kHz) microvolts per meter at 30 meters is allowed between 510–1600 kHz. This is 15 uv/m at 1600 kHz 100 feet from the transmitter. Below 490 kHz, $2400/f$ (kHz) at 300 meters is allowed. This is 12 uv/m at 1000 feet. These levels are that of a weak AM broadcast band station. Alternatively, 100 mW of RF into a 10-foot antenna is allowed in the AM broadcast band, and 1 watt of RF is allowed into a 50-foot antenna between 160–190 kHz. These figures actually assume 100 percent power amplifier efficiency, and the power is defined as input to the final RF amplifier stage.

This information is from the vacuum tube days when RF power was not easily measured with simple equipment; however, nowadays solid-state RF amplifiers are specified in terms of RF output. An efficiency of 60–80 percent is typical of transistor power amplifiers, although 90 percent or more may be reached in some instances. Therefore, to comply with Part 15 of the FCC rules, either make sure the RF output is kept at 1.6–2 volts rms or less into a 50-ohm load, or use the unmatched 4-foot whip antenna. *Do not* use the 100-mW input into a 10-foot antenna unless you can measure and verify the RF output power. Although you may operate anywhere in the AM band, the high end (1600 kHz) is preferred because antenna efficiency is better.

A center-loaded 10-foot radiator may also be used (see Figure A-1). See Figures A-3 for a typical center-loading coil used with an 8-foot whip. This involves splitting the radiator into two sections and adding an inductance to bring the radiator to resonance at the desired frequency. Approximately enough inductance is needed to resonate with the self-capacitance of the top whip antenna. For 1600 kHz, this is on the order of 400–1000 microhenries, depending on whip length and diameter, as well as frequency. A good ground system is required, and antenna bandwidth of 10 kHz is typical. Radiation resistances of 0.1–0.3 ohms are typical, and the radiation efficiency of a system such as this one is a few percent at best, assuming ideal grounding, and 0.5 percent for the typical home experimenter setup; however, experience at 1880 kHz with 160-meter amateur mobile operation, using 10 watts AM and a center-loaded 8-foot whip mounted on an automobile, shows that two-way contacts at 30–60 miles are possible and fairly common. Extrapolating this data based on theory, with 100 mW (20 dB below 10 watts), therefore, ranges of 3–6 miles would seem possible without violating FCC rules; however, noise and interference are the main limitations. It is all in the location and antenna system and how well everything is tuned and matched.

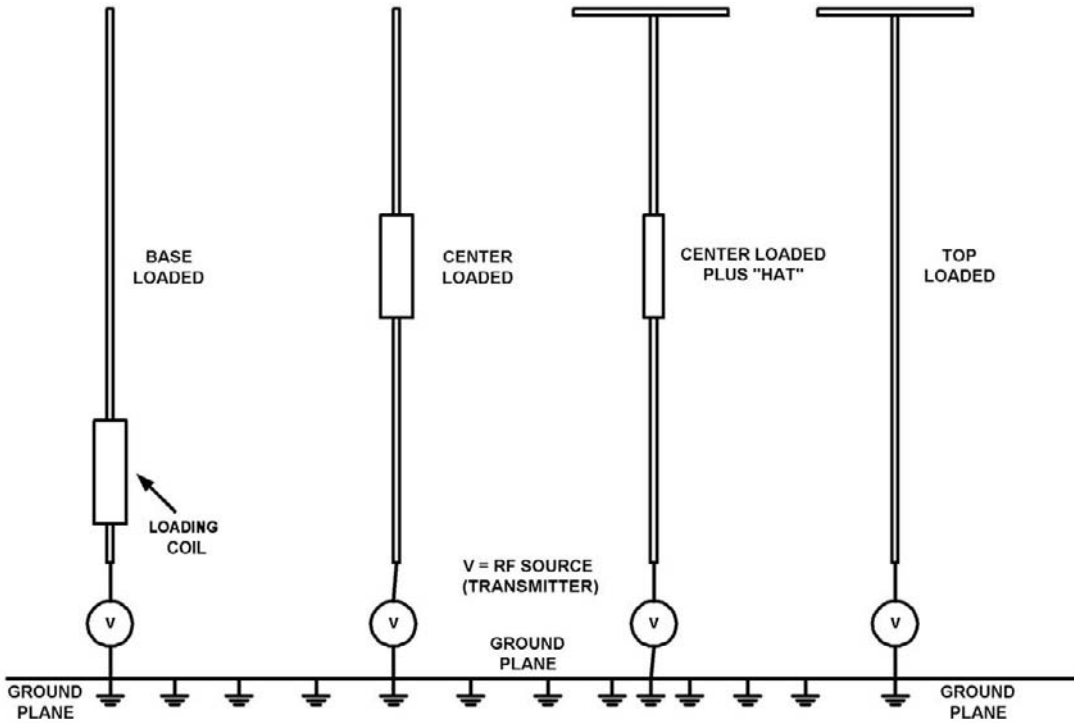

Figure A-1
Types of Vertical Antennas Suitable for Low Power Transmitters

The FCC rules specifically state a 10-foot antenna and ground length, however. The wire used in the loading coil could count if it radiates. A helical whip using 200–300 feet of wire wound on a pole 8–10 feet long would physically appear to be a legal antenna, especially if it has a plastic jacket; however, these helical antennas commonly used for HF mobile SSB communication would likely be illegal unless the wire was wound in a specific configuration so as not to have more than 10 feet radiating. This is a continuously loaded antenna, and you cannot easily separate the inductor from the antenna, so some kind of legal interpretation and clarification may be needed. Use of these antennas with their legality question is at the discretion of the experimenter. Operating in the 160-meter ham band (General Class license needed; a Code-Free Technician class *will not do*) sidesteps these problems of legality as long as the transmitter is not used for commercial purposes of any kind.

Part 15 160–190 KHZ (1750 Meters)

In this band, no license is required (although several experimenters using this band are also licensed hams). CW (Morse code) is predominant because of the weak-signal narrowband capability of this mode. Some experimenters have set up CW radiobeacons for others to try to copy and send them reception reports. Distances of 10–30 miles are routine, with a few reports of more than 100 miles, and in one instance, 800 miles. This latter feat requires a very low-noise, rural receiving

Figure A-2
Collapsible Whip
Antenna for Low
Power FM Trans-
mitters

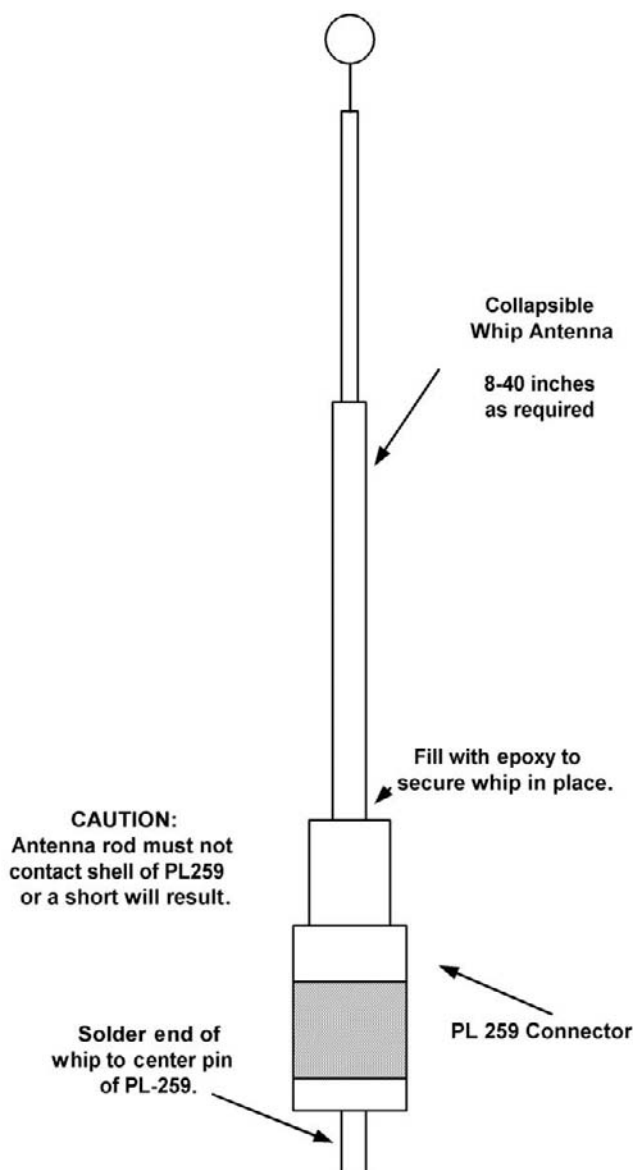

location away from power lines and other sources of manmade noise, very well tuned and matched antennas, and a very sensitive (less than 0.01 microvolt) narrowband (200- to 400-Hz-wide) receiver. This feat requires knowledge, dedication, and patience, but it shows what can be done. A receiver of 200-Hz bandwidth and 1 dB noise figure has a -157 dBm noise floor (0.003 microvolts into 50 ohms approximately), and a good CW operator can copy a very weak Morse code signal equal to the noise level. Considering that the efficiency of a 50-foot vertical antenna at 180 kHz is probably less than a fraction of a percent (0.3–0.5 percent is typical), this is not bad DX for 3–5 mW effective radiated power.

More details of this mode of operation can be obtained from the Longwave Club of America, 45 Wildflower Rd., Levittown, PA 19057; telephone (215) 945-0543. If

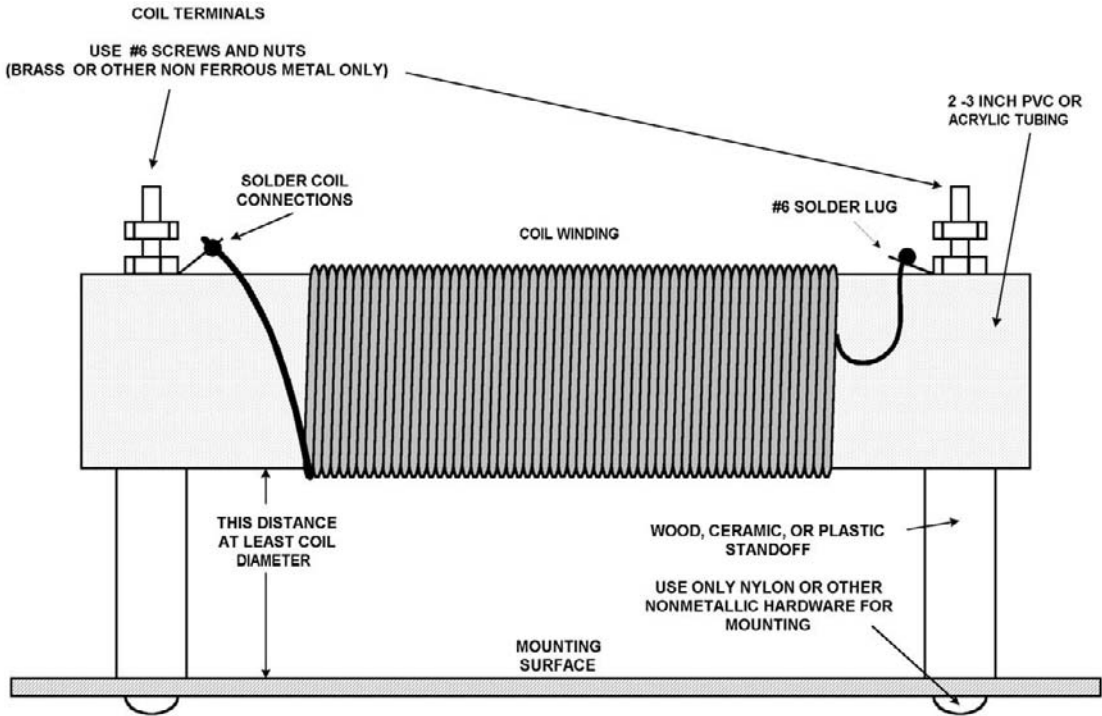

Figure A-3 Loading Coil Construction for 1650 kHz AM Antenna

you can locate a copy of it, an excellent source of information is the *Low and Medium Frequency Scrapbook*, by the late Ken Cornell, W2IMB, published by Communications Technology, Inc., 1977. This book is a classic in this field and still an excellent reference. The circuits are naturally somewhat dated (some are vacuum tube), but the principles are still the same and the ideas still apply. The antenna information and experimental data are a gold mine of information in this field. Several experimenters' publications, such as *QST*, *CQ magazine*, *Ham Radio* (defunct), and *73 magazine*, as well as *Electronics Now* (formerly *Radio Electronics*) and *Popular Electronics*, have run articles in past issues on the subject. Some of these articles, being "older" traditional technology, appeared 20 years ago or more but are still applicable. In addition, the Radio Society of Great Britain has a book called the *LF Sourcebook*. This book is also excellent and describes operation at 73 and 136 kHz as well as 160–190 kHz. Being a more recent book, it is somewhat more up to date as far as circuit approaches and has good antenna articles applicable to LF operation. (See Figure A-4 for a ground system.)

FM Dipole for 88–108 MHz

A simple dipole antenna can be used for improved reception of FM broadcast signals. A dipole is basically a length of conductor (wire) split into two portions, and signal is taken off at the split. A dipole has a nominal 3 dB gain over an isotropic source and is directional, tending to favor signals coming broadside to the wire. The

Figure A-4
 Typical Ground
 Systems Low-
 Power and LF
 Transmitters that
 meet Part 15

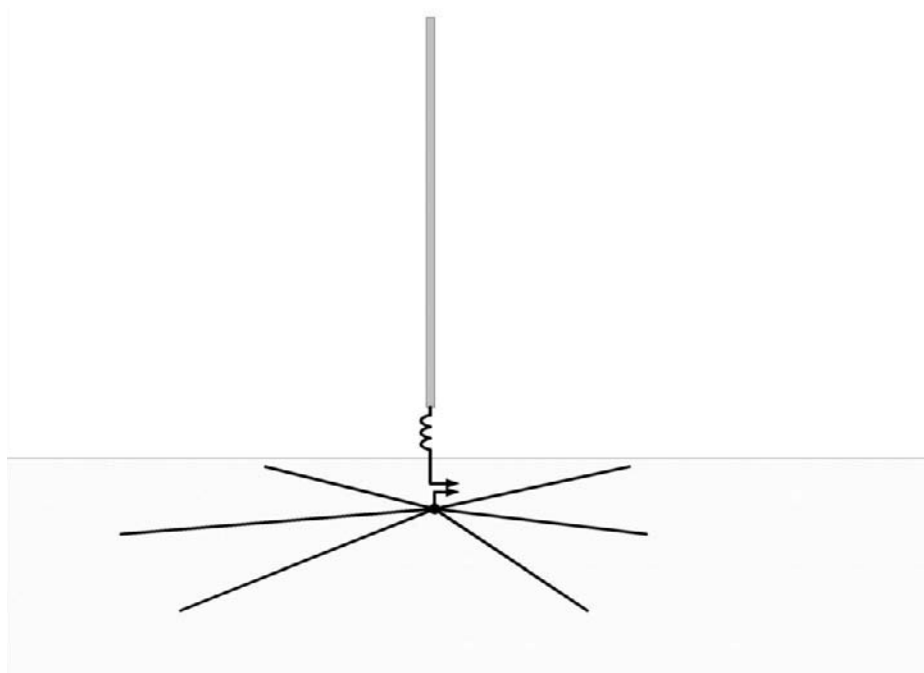

dipole is customarily an electrical half-wavelength of wire at the frequency of interest because the impedance under this condition is theoretically 72 ohms resistive and is a good match to a 50- to 75-ohm source or load generally presented by interfacing equipment such as receivers and transmitters designed to work in this range of impedances.

The length of a half-wave dipole in feet is calculated as 468 divided by the frequency in MHz or in inches as $5606/f$ MHz. This formula takes “end effect” and the fact that the dipole elements are of finite thickness into consideration and works out fairly close in practice. Therefore, a dipole for 98 MHz, which is band center of the FM broadcast band, calculates out as 4.78 feet or 57.3 inches. The dipole would then consist of two lengths of wire each 2.39 feet or 28.65 inches long. Coaxial cable can be used to connect to the antenna, but for best results, a balun should be used to prevent feedline radiation or pickup, which tends to distort the pattern. For 88–108 MHz, this can be made by winding the coaxial feedline through a toroidal core or around a ferrite rod. The idea is to insert a series impedance to shield currents on the outside of the outer conductor, effectively decoupling it from the antenna. The current inside the line does not see this because the inner and outer conductors are carrying equal and opposite currents and produce no external magnetic field, so no loss is experienced.

The ferrite can be almost anything that yields a high impedance at the operating frequency. For 88–108 MHz, this can be a small toroid or rod with three to four turns of the cable. We used a Ferroxcube part number 768T188 made from 4C4 material specified for 1–20 MHz, wound with three turns of RG 174/U miniature coax. The measured loss was 0.3 dB, including two connectors in the test setup, and the impedance across the toroid effectively in series with the outer surface of the shield was 1100 ohms shunted by -1.2 pf as read on a Boonton RX meter. This is more than 10 times the feedline impedance and should be adequate. The antenna should be mounted high and in the clear for best results (30 feet away from anything else) and oriented facing the favored direction of reception.

Antennas and Induced Hum in Low-Power Transmitters

It is convenient and easy to use a wall transformer with a low-power FM transmitter, but we do not recommend it for best results unless proper measures are taken to avoid induced hum. Hum modulation appearing on the transmitted audio signal can be a problem. *This is not caused by insufficient filtering of the DC voltage.* Rather, it has to do with induced modulation of the RF ground return caused by the nonlinearity of the rectifier diodes in the wall transformer. What happens is that the case and PC board ground foil and any other conductive material acts as a ground plane for the antenna. Because the power supply cord is connected to the transmitter, it is part of this ground plane. The windings of the transformer in the wall supply are closely coupled for RF energy; therefore, even the AC house wiring acts as part of the ground plane. The rectifier diodes are in series with the power cord and the AC house wiring, however, as far as RF is concerned.

The diode impedance for RF is forced to vary at the 50–60 Hz line frequency, which effectively modulates the ground plane impedance. This introduces incidental hum modulation into the transmitted signal. Although this is largely an AM component, no FM system is perfectly free from AM susceptibility, and it is easy to wind up with a hum component that is 40–50 dB below peak audio level. This hum is annoying and noticeable. It has nothing to do with the transmitter circuit design being a function of the wall transformer and the environment. It is reduced by bypassing the rectifier diodes, using RF chokes in the supply lines and a large ground plane immediately under the antenna, or by using a balanced antenna such as a dipole with a good balun transformer; however, these measures are not practical because wall transformers are generally sealed. Because many low-power transmitter users want to simply use a small whip antenna mounted on the rear of the transmitter, the previously mentioned precautions must be taken to avoid induced hum in the transmitted signal. A good earth ground, such as a cold water pipe that is known to be grounded, or a ground consisting of several 8- to 10-foot ground rods spaced at least their length apart and connected together with a heavy ground wire, should be used if available. This kind of ground is most effective at low (less than 1 MHz) frequencies. If no ground is available, you should consider using a balanced coaxial feed antenna, such as a dipole.

Antenna Considerations and Range Expectations

The results you obtain with low-power ATV transmitters depend on the following factors, which are listed in order of importance:

1. Antennas and height thereof
2. Expected picture quality
3. Path of propagation of signals
4. Geographic location and terrain
5. Presence of interference
6. Receiver sensitivity
7. Transmitter power

A frequently asked question concerns performance with regard to how much range specific antenna, transmitter, and receiver setups will have. Although it is theoretically possible to predict this in free space, environmental factors present on this

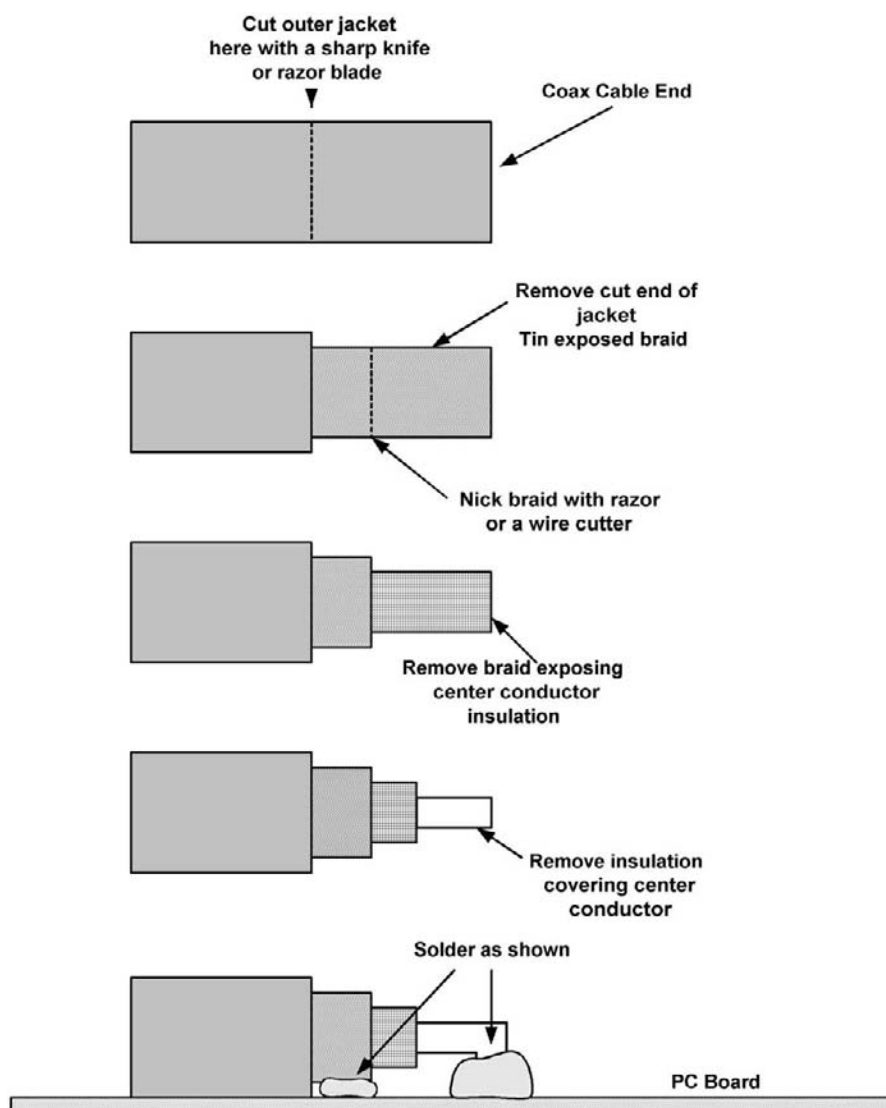

Figure A-5
Correct Method of
Attaching Coaxial
Cable to PC Board.

planet affect this prediction in an unfortunately negative manner. Like the weather for next year, this information is difficult to predict and impossible to guarantee. It has nothing to do with the manufacturer or kinds of circuits. To demonstrate what is involved, we compare an ATV system to a radio system using a 2-watt walkie-talkie, such as those used by hams, police, or security personnel, and so forth. These devices have ranges varying from 1/4 mile in bad locations to 10 or more miles from a good location such as a hilltop. No repeaters are assumed, just simplex operation to another walkie-talkie or base setup. Typically, these units have receivers with 0.2-microvolt sensitivity at threshold and small whip antennas with zero gain or less. System bandwidth is typically 13 kHz for two-way narrowband FM receivers, and transmitter deviation is usually 5 kHz.

Remember that ordinary TV broadcast (and most ATV) NTSC format signals need 3–5 MHz bandwidth depending on resolution and whether they are black and white or color, so the receiver must have this bandwidth. Because thermal noise

limits sensitivity and is directly proportional to bandwidth, a TV receiver has a much larger background noise level. Assuming that the TV receiver and the HT have similar noise figures (3–6 dB is typical), then the ratio of background noise power is:

$$\begin{aligned} \text{Noise of TV receiver} \div \text{Noise of HT receiver} &= 5 \text{ MHz} \\ \div 13 \text{ kHz} &= 5,000,000 \div 13,000 = 384.61 \text{ or } 385 \text{ times} \end{aligned}$$

The TV receiver must contend with 385 times as much noise power as does the radio receiver. Also, consider the fact that an 8 dB signal-to-noise power ratio gives adequate copy on the radio, but 8 dB is useless for any watchable picture. Some receivers need at least 10–15 dB just to hold sync. You would not watch a TV picture with a 20 dB signal-to-noise ratio because it would be very snowy, and 30 dB would still be somewhat snowy. Therefore, another 22 dB more signal is needed at the TV set at the minimum. This 22 dB is 158 times more received signal power. For a good cable-quality picture, 45–50 dB is the minimum. For ham use, the 30 dB figure might be adequate. This means that 385×158 or 60,830 times the signal power is needed at the TV receiver. This is a ratio of 48 dB; however, this number is not as bleak as it may sound. A good amateur installation would use directional Yagi antennas at both receiver and transmitter sites, having 15–20 dB gain, low-noise (less than 3dB noise figure) downconverters, and possibly 100- to 200-watt linear amplifiers. This could increase system gain by $(15 + 15 + 3)$ or 33 dB, and if a 100-watt linear amplifier is used, another 17 dB (assuming a 2-watt ATV transmitter as an exciter). This is 50 dB and even more if 20 dB gain antennas are used, and higher power up to 1 kW for a total of 70 dB possible. A station like this would have an effective radiated power of 1–100 kW. The latter figure is typical of a UHF broadcast station.

A relatively low-power transmitter with an effective antenna far outperforms a higher-power transmitter with a mediocre antenna. An average receiver with a good antenna likewise far outperforms a more sensitive receiver with a simple whip or loop antenna. Remember that at UHF, propagation is generally restricted to line of sight. If both receiver and transmitter sites have good antennas (10- to 15-element Yagi or better) and a relatively unobstructed path exists between the sites, ranges of 30–100 miles can be obtained. On the other extreme, if simple antennas such as 6-inch whip antennas are used in rough or hilly terrain, 1/2 mile would be doing well. In cities with concrete and steel structures, this range might be reduced to as little as 100 yards. Therefore, the antenna system is the single most important factor in regard to range obtained. At 915 and 1260 MHz, simple whip antennas are nearly useless for significant range, and there are no cure-all circuits to improve this limitation.

For many years, a lot of research has gone into small antennas, and there seems to be no way to get around this problem. You have to radiate the transmitter power efficiently and at the receiving site capture as much as possible. It has nothing to do with the kind of transmitter or receiver being used. There simply are no magic tricks. Poor antennas give poor results. Miniature antennas yield miniature results. Theoretically, a small antenna can be efficient, but in practice the very low radiation resistances encountered are difficult to match without high losses in the required matching networks. Also, bandwidth can be a problem, and NTSC television needs 4 MHz for good definition. Some antennas may be a problem in this regard, as for example, long Yagis with gamma match feed. On the other hand, big antennas generally yield big results if properly tuned and matched. ATV operation, unlike 2-meter FM or HF SSB operation, is not a “plug together and play” business if you want best results. To get good results, all peripheral equipment must be compatible and properly interfaced, video levels must be correct, and you must do your homework on your antenna system. Proper setup is needed to get best results.

All antennas have a gain factor expressed in decibels. Usually, this factor is relative to an isotropic radiator. An isotropic radiator radiates uniformly in all directions, as does a point source of light. All the power that the transmitter produces ideally is radiated by the antenna; however, this is not generally true in practice because there are losses in both the antenna and its associated feedline. The transmitted power is effectively multiplied by the antenna system gain, which is the sum of the line losses and the antenna gain (or loss for many small simple antennas). The gains in decibels directly add and may be expressed as a numerical factor. The transmitter power and the antenna gain when multiplied equal the effective radiated power (ERP). Directional gain antennas, such as Yagi arrays and log periodics, increase the range and reduce interference and ghosting. You should do everything possible at the receiver before attempting to make improvements at the transmitter end of the path. This is the least expensive, most environmentally sound, and best engineering practice and will reduce RF pollution for other users of the spectrum.

Next, install a good directional transmitting antenna and a low-loss feedline. Use only low-loss coax, and if more than 40–50 feet, use hardline because line losses are high at 440 MHz and still higher at 915 and 1280 MHz. Also remember that obstructions such as buildings, hills, foliage, and large metal structures can cause shadows in the propagation path, limiting coverage in these areas. This effect becomes more pronounced at higher frequencies. Also, although some “fill” occurs in these shadow areas because of reflections, diffraction, and some scattering, multiple paths and reflections can cause ghosting problems. A good directional antenna can help to reduce these effects. The most ineffective way to reduce these effects from a cost standpoint is to use more transmitter power. You will be disappointed if you use this method to increase range. Good antennas are far more effective than brute force, and increased power is *always the last resort*.

Some typical figures follow. Antenna gain also counts at the receiver in the same way. Always use the better antenna at the receiving site if at all possible.

Table A-1
Expectation of Antenna Performance

Type Antenna	Gain db	Improvement Factor	ERP with 2-Watt XMTR
Makeshift, no or poor ground	–30 to –10	0.001–0.1	0.002–0.2 watts
Rubber Duckie	–20 to –2	0.01–0.7	0.02–1.4 watts
1/4 wave whip (poor ground)	–20 to –6	0.01–0.25	0.02–0.5 watts
1/4 wave whip w/ ground plane	–2 to 0	0.64–1.0	1.3–2 watts
Discone	–6 to 0	0.25–1.0	0.5–2 watts
5/8 wave whip	0 to +3	1–2	2–4 watts
1/2 wave dipole	0 to +3	1–2	2–4 watts
Vertical collinear	+3 to +6	2–4	4–8 watts
3-element Yagi	+3 to +8	2–6	4–12 watts
Log periodic array	+5 to +9	5–8	10–16 watts
Corner reflector	+6 to +10	4–10	8–20 watts
Helical antenna	+8 to +13	6–20	12–40 watts
10-element Yagi	+10 to +12	10–16	20–32 watts
15-element Yagi	+14 to +15	25–32	50–64 watts
4 stacked Yagis, 15 elements or larger	+17 to +20	50–100	100–200 watts
Dish, parabolic (practical at 915 and 1260 MHz)	+15 to +25	32–316	64–732 watts

Gains are practically observed in actual use, not theoretical figures.

Build Your Own Low-Power Transmitters: Projects for the Electronics Experimenter

You can see the dramatic difference in using good antennas. To increase range, perform the following steps, in order of priority:

1. Use a better receiving antenna with 8 dB or higher gain.
2. Use a low-noise downconverter and/or a low-noise preamplifier.
3. Increase the height of the receive antenna.
4. Make sure to use low-loss feedlines, as short as possible.
5. Increase the height of the transmitting antenna.
6. Use a better transmitting antenna if possible.
7. If possible, use black and white instead of color video because less bandwidth is required.
8. If audio is unnecessary, disable the sound subcarrier to reduce bandwidth.
9. Increase the transmitter power only as a *last resort*.

For more antenna information, consult a good text on antennas, such as the *ARRL Antenna Handbook*, and antenna manufacturers' literature. Another excellent reference text is the Radio Society of Great Britain (RSGB) handbook. This latter text has much detailed information for home construction. These books may be obtained from most amateur radio dealers or directly from the American Radio Relay League, 225 Main Street, Newington CT 06111 USA.

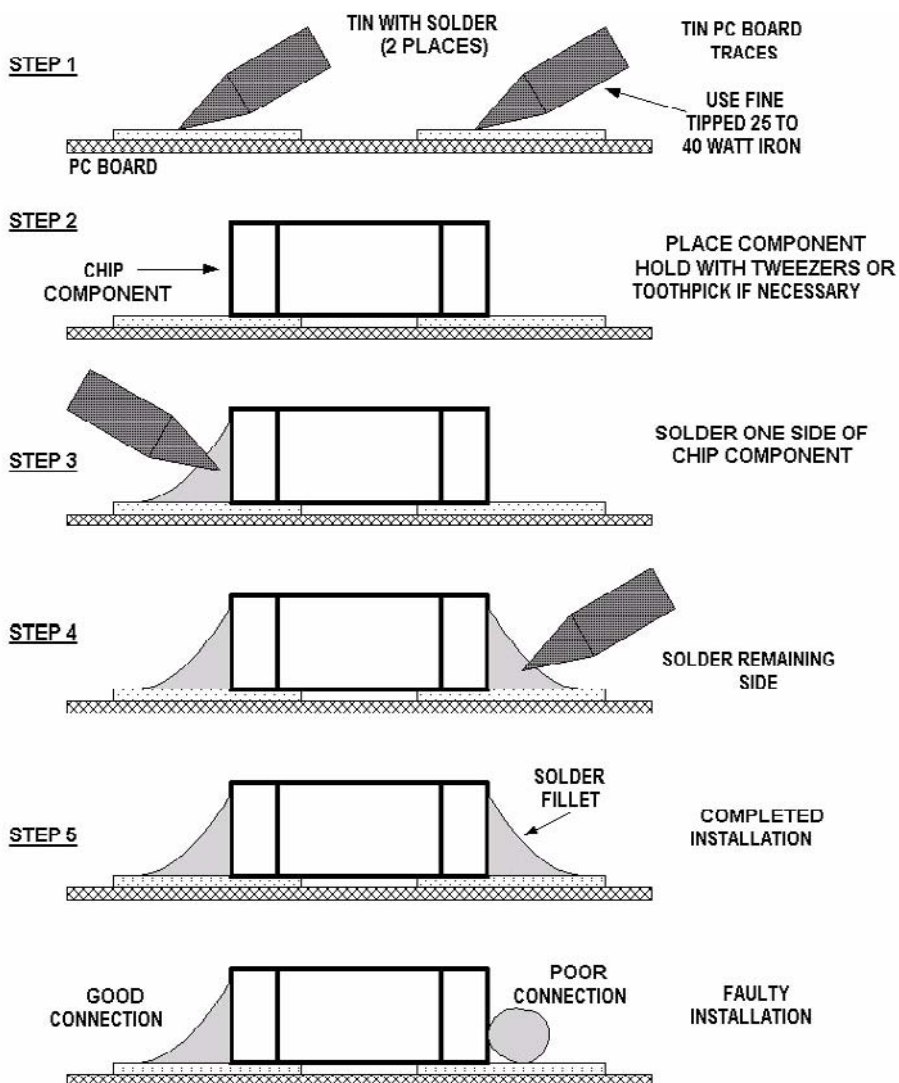

Figure A-6
 Chip Component
 Installation

This Page Intentionally Left Blank