

FIRST AID
A NEW book contains
FREE access to essential
online resources
for a better grade!

Introduction to

ELECTRIC CIRCUITS

SIXTH EDITION

*with Electric
Circuit Study
Applets*

RICHARD C. DORF | JAMES A. SVOBODA

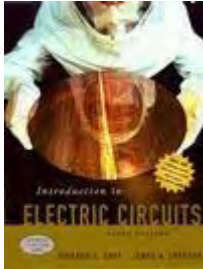

Solution Manual

to accompany

Introduction to Electric Circuits, 6e

By R. C. Dorf and J. A. Svoboda

Table of Contents

Chapter 1 Electric Circuit Variables

Chapter 2 Circuit Elements

Chapter 3 Resistive Circuits

Chapter 4 Methods of Analysis of Resistive Circuits

Chapter 5 Circuit Theorems

Chapter 6 The Operational Amplifier

Chapter 7 Energy Storage Elements

Chapter 8 The Complete Response of RL and RC Circuits

Chapter 9 The Complete Response of Circuits with Two Energy Storage Elements

Chapter 10 Sinusoidal Steady-State Analysis

Chapter 11 AC Steady-State Power

Chapter 12 Three-Phase Circuits

Chapter 13 Frequency Response

Chapter 14 The Laplace Transform

Chapter 15 Fourier Series and Fourier Transform

Chapter 16 Filter Circuits

Chapter 17 Two-Port and Three-Port Networks

Errata for Introduction to Electric Circuits, 6th Edition

Page 18, voltage reference direction should be + on the right in part B:

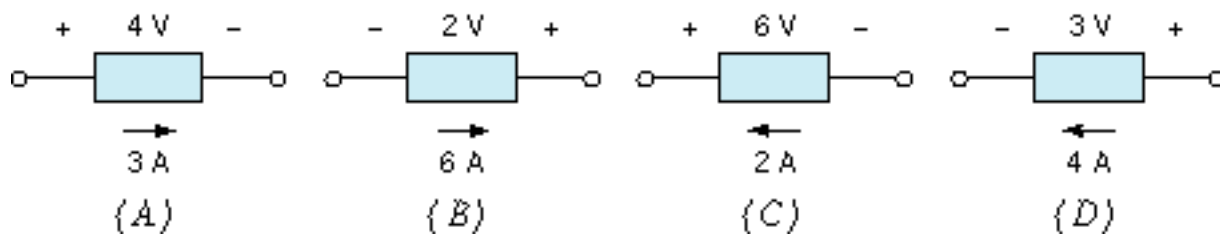

Page 28, caption for Figure 2.3-1: "current" instead of "cuurent"

Page 41, line 2: "voltage or current" instead of "voltage or circuit"

Page 41, Figure 2.8-1 b: the short circuit is drawn as an open circuit.

Page 42, line 11: "Each dependent source ..." instead of "Each dependent sources..."

Page 164, Table 5.5-1: method 2, part c, one should insert the phrase "Zero all independent sources, then" between the "(c)" and "Connect a 1-A source. . ." The edited phrase will read:

"Zero all independent sources, then connect a 1-A source from terminal b to terminal a. Determine V_{ab} .
Then $R_t = V_{ab}/1$."

Page 340, Problem P8.3-5: The answer should be $v_o(t) = 10 - 5e^{-12.5t}$ V for $t > 0$.

Page 340, Problem P8.3-6: The answer should be $v_o(t) = 5e^{-4000t}$ V for $t > 0$.

Page 341, Problem P.8.4-1: The answer should be
$$v(t) = \begin{cases} 5 + 5e^{-5t} \text{ V for } 0 < t < 1.5 \text{ s} \\ 10 - 5e^{-2.5(t-1.5)} \text{ V for } 1.5 \text{ s} < t \end{cases}$$

Page 546, line 4: The angle is θ_{AI} instead of θ_{IA} .

Page 554, Problem 12.4.1 Missing parenthesis: $V_a = (208/\sqrt{3}) \angle -30^\circ$

Page 687, Equation 15.5-2: Partial t in exponent: $e^{j\omega_0 t}$

Page 757, Problem 16.5-7: $H_b(s) = V_2(s) / V_1(s)$ and $H_c(s) = V_2(s) / V_s(s)$ instead of $H_b(s) = V_1(s) / V_2(s)$ and $H_c(s) = V_1(s) / V_s(s)$.

Chapter 1 – Electric Circuit Variables

Exercises

Ex. 1.3-1

$$i(t) = 8t^2 - 4t \text{ A}$$

$$q(t) = \int_0^t i d\tau + q(0) = \int_0^t (8\tau^2 - 4\tau) d\tau + 0 = \frac{8}{3}\tau^3 - 2\tau^2 \Big|_0^t = \frac{8}{3}t^3 - 2t^2 \text{ C}$$

Ex. 1.3-3

$$q(t) = \int_0^t i(\tau) d\tau + q(0) = \int_0^t 4\sin 3\tau d\tau + 0 = -\frac{4}{3}\cos 3\tau \Big|_0^t = -\frac{4}{3}\cos 3t + \frac{4}{3} \text{ C}$$

Ex. 1.3-4

$$i(t) = \frac{dq(t)}{dt} \quad i(t) = \begin{cases} 0 & t < 0 \\ 2 & 0 < t < 2 \\ -2e^{-2(t-2)} & t > 2 \end{cases}$$

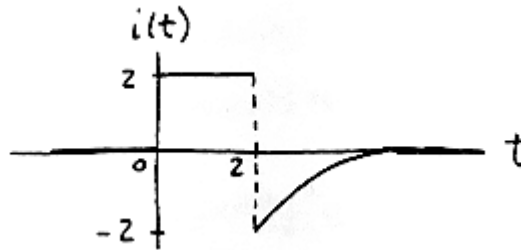

Ex. 1.4-1

$$i_1 = 45 \mu\text{A} = 45 \times 10^{-6} \text{ A} < i_2 = 0.03 \text{ mA} = .03 \times 10^{-3} \text{ A} = 3 \times 10^{-5} \text{ A} < i_3 = 25 \times 10^{-4} \text{ A}$$

Ex. 1.4-2

$$\Delta q = i\Delta t = (4000 \text{ A})(0.001 \text{ s}) = \underline{4 \text{ C}}$$

Ex. 1.4-3

$$i = \frac{\Delta q}{\Delta t} = \frac{45 \times 10^{-9}}{5 \times 10^{-3}} = 9 \times 10^{-6} = 9 \mu\text{A}$$

Ex. 1.4-4

$$\begin{aligned} i &= \left[10 \text{ billion} \frac{\text{electron}}{\text{s}} \right] \left[1.602 \times 10^{-19} \frac{\text{C}}{\text{electron}} \right] = \left[10 \times 10^9 \frac{\text{electron}}{\text{s}} \right] \left[1.602 \times 10^{-19} \frac{\text{C}}{\text{electron}} \right] \\ &= 10^{10} \times 1.602 \times 10^{-19} \frac{\text{electron}}{\text{s}} \frac{\text{C}}{\text{electron}} \\ &= 1.602 \times 10^{-9} \frac{\text{C}}{\text{s}} = \underline{1.602 \text{ nA}} \end{aligned}$$

Ex. 1.6-1

- (a) The element voltage and current do not adhere to the passive convention in Figures 1.6-1B and 1.6-1C so the product of the element voltage and current is the power supplied by these elements.
- (b) The element voltage and current adhere to the passive convention in Figures 1.6-1A and 1.6-1D so the product of the element voltage and current is the power delivered to, or absorbed by these elements.
- (c) The element voltage and current do not adhere to the passive convention in Figure 1.6-1B, so the product of the element voltage and current is the power delivered by this element: $(2 \text{ V})(6 \text{ A}) = 12 \text{ W}$. The power received by the element is the negative of the power delivered by the element, -12 W .
- (d) The element voltage and current do not adhere to the passive convention in Figure 1.6-1B, so the product of the element voltage and current is the power supplied by this element: $(2 \text{ V})(6 \text{ A}) = 12 \text{ W}$.
- (e) The element voltage and current adhere to the passive convention in Figure 1.6-1D, so the product of the element voltage and current is the power delivered to this element: $(2 \text{ V})(6 \text{ A}) = 12 \text{ W}$. The power supplied by the element is the negative of the power delivered to the element, -12 W .

Problems**Section 1-3 Electric Circuits and Current Flow****P1.3-1**

$$i(t) = \frac{d}{dt} 4(1 - e^{-5t}) = 20e^{-5t} \text{ A}$$

P1.3-2

$$q(t) = \int_0^t i(\tau) d\tau + q(0) = \int_0^t 4(1 - e^{-5\tau}) d\tau + 0 = \int_0^t 4 d\tau - \int_0^t 4e^{-5\tau} d\tau = 4t + \frac{4}{5}e^{-5t} - \frac{4}{5} \text{ C}$$

P1.3-3

$$q(t) = \int_{-\infty}^t i(\tau) d\tau = \int_{-\infty}^t 0 d\tau = 0 \text{ C for } t \leq 2 \text{ so } q(2) = 0.$$

$$q(t) = \int_2^t i(\tau) d\tau + q(2) = \int_2^t 2 d\tau = 2\tau \Big|_2^t = 2t - 4 \text{ C for } 2 \leq t \leq 4. \text{ In particular, } q(4) = 4 \text{ C.}$$

$$q(t) = \int_4^t i(\tau) d\tau + q(4) = \int_4^t -1 d\tau + 4 = -\tau \Big|_4^t + 4 = 8 - t \text{ C for } 4 \leq t \leq 8. \text{ In particular, } q(8) = 0 \text{ C.}$$

$$q(t) = \int_8^t i(\tau) d\tau + q(8) = \int_8^t 0 d\tau + 0 = 0 \text{ C for } 8 \leq t.$$

P1.3-4

$$i = 600 \text{ A} = 600 \frac{\text{C}}{\text{s}}$$

$$\text{Silver deposited} = 600 \frac{\text{C}}{\text{s}} \times 20 \text{ min} \times 60 \frac{\text{s}}{\text{min}} \times 1.118 \frac{\text{mg}}{\text{C}} = 8.05 \times 10^5 \text{ mg} = \underline{805 \text{ g}}$$

Section 1-6 Power and Energy**P1.6-1**

$$\text{a.) } q = \int i dt = i \Delta t = (10 \text{ A})(2 \text{ hrs})(3600 \text{ s/hr}) = \underline{7.2 \times 10^4 \text{ C}}$$

$$\text{b.) } P = v i = (110 \text{ V})(10 \text{ A}) = \underline{1100 \text{ W}}$$

$$\text{c.) } \text{Cost} = \frac{0.06 \$}{\text{kWhr}} \times 1.1 \text{ kW} \times 2 \text{ hrs} = \underline{0.132 \$}$$

P1.6-2

$$P = (6 \text{ V})(10 \text{ mA}) = 0.06 \text{ W}$$

$$\Delta t = \frac{\Delta w}{P} = \frac{200 \text{ W}\cdot\text{s}}{0.06 \text{ W}} = \underline{3.33 \times 10^3 \text{ s}}$$

P1.6-3

$$\text{for } 0 \leq t \leq 10 \text{ s: } v = 30 \text{ V} \text{ and } i = \frac{30}{15}t = 2t \text{ A} \quad \therefore \underline{P = 30(2t) = 60t \text{ W}}$$

$$\text{for } 10 \leq t \leq 15 \text{ s: } v(t) = -\frac{25}{5}t + b \Rightarrow v(10) = 30 \text{ V} \Rightarrow b = 80 \text{ V}$$

$$v(t) = -5t + 80 \text{ and } i(t) = 2t \text{ A} \Rightarrow \underline{P = (2t)(-5t + 80) = -10t^2 + 160t \text{ W}}$$

$$\text{for } 15 \leq t \leq 25 \text{ s: } v = 5 \text{ V} \text{ and } i(t) = -\frac{30}{10}t + b \text{ A}$$

$$i(25) = 0 \Rightarrow b = 75 \Rightarrow i(t) = -3t + 75 \text{ A}$$

$$\therefore \underline{P = (5)(-3t + 75) = -15t + 375 \text{ W}}$$

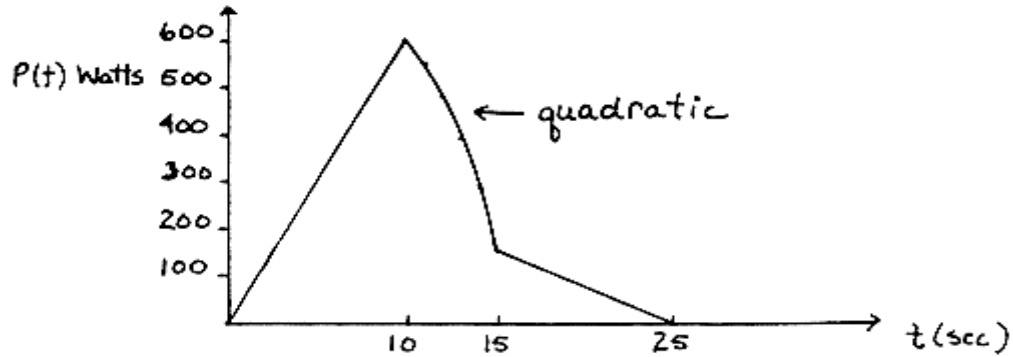

$$\begin{aligned} \text{Energy} &= \int P dt = \int_0^{10} 60t dt + \int_{10}^{15} (160t - 10t^2) dt + \int_{15}^{25} (375 - 15t) dt \\ &= 30t^2 \Big|_0^{10} + 80t^2 - \frac{10}{3}t^3 \Big|_{10}^{15} + 375t - \frac{15}{2}t^2 \Big|_{15}^{25} = 5833.3 \text{ J} \end{aligned}$$

P1.6-4

a.) Assuming no more energy is delivered to the battery after 5 hours (battery is fully charged).

$$\begin{aligned} w &= \int P dt = \int_0^t vi d\tau = \int_0^{5(3600)} 2 \left(11 + \frac{0.5 \tau}{3600} \right) d\tau = 22t + \frac{0.5}{3600} \tau^2 \Big|_0^{5(3600)} \\ &= 441 \times 10^3 \text{ J} = \underline{441 \text{ kJ}} \end{aligned}$$

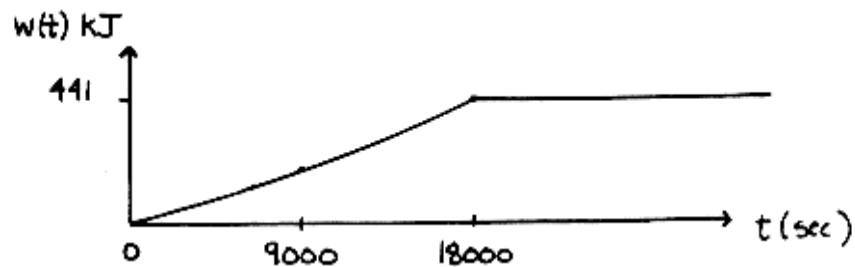

$$\text{b.) Cost} = 441 \text{ kJ} \times \frac{1 \text{ hr}}{3600 \text{ s}} \times \frac{10 \text{¢}}{\text{kWhr}} = \underline{1.23 \text{¢}}$$

P1.6-5

$$p(t) = \frac{1}{3}(\cos 3t)(\sin 3t) = \frac{1}{6} \sin 6t$$

$$p(0.5) = \frac{1}{6} \sin 3 = 0.0235 \text{ W}$$

$$p(1) = \frac{1}{6} \sin 6 = -0.0466 \text{ W}$$

Here is a MATLAB program to plot $p(t)$:

```
clear

t0=0;           % initial time
tf=2;           % final time
dt=0.02;        % time increment
t=t0:dt:tf;     % time

v=4*cos(3*t);   % device voltage
i=(1/12)*sin(3*t); % device current

for k=1:length(t)
    p(k)=v(k)*i(k); % power
end

plot(t,p)
xlabel('time, s');
ylabel('power, W')
```

P1.6-6

$$p(t) = 16(\sin 3t)(\sin 3t) = 8(\cos 0 - \cos 6t) = 8 - 8\cos 6t \text{ W}$$

Here is a MATLAB program to plot $p(t)$:

```
clear

t0=0;           % initial time
tf=2;           % final time
dt=0.02;        % time increment
t=t0:dt:tf;     % time

v=8*sin(3*t);   % device voltage
i=2*sin(3*t);   % device current

for k=1:length(t)
    p(k)=v(k)*i(k); % power
end

plot(t,p)
xlabel('time, s');
ylabel('power, W')
```

P1.6-7

$$p(t) = 4(1 - e^{-2t}) \times 2e^{-2t} = 8(1 - e^{-2t})e^{-2t}$$

Here is a MATLAB program to plot $p(t)$:

```
clear

t0=0;           % initial time
tf=2;           % final time
dt=0.02;        % time increment
t=t0:dt:tf;     % time

v=4*(1-exp(-2*t)); % device voltage
i=2*exp(-2*t);    % device current

for k=1:length(t)
    p(k)=v(k)*i(k); % power
end

plot(t,p)
xlabel('time, s');
ylabel('power, W')
```

P1.6-8

$$P = VI = 3 \times 0.2 = \underline{0.6 \text{ W}}$$

$$w = P \cdot t = 0.6 \times 5 \times 60 = \underline{180 \text{ J}}$$

Verification Problems

VP 1-1

Notice that the element voltage and current of each branch adhere to the passive convention. The sum of the powers absorbed by each branch are:

$$\begin{aligned}(-2 \text{ V})(2 \text{ A})+(5 \text{ V})(2 \text{ A})+(3 \text{ V})(3 \text{ A})+(4 \text{ V})(-5 \text{ A})+(1 \text{ V})(5 \text{ A}) &= -4 \text{ W} + 10 \text{ W} + 9 \text{ W} -20 \text{ W} + 5 \text{ W} \\ &= 0 \text{ W}\end{aligned}$$

The element voltages and currents satisfy conservation of energy and may be correct.

VP 1-2

Notice that the element voltage and current of some branches do not adhere to the passive convention. The sum of the powers absorbed by each branch are:

$$\begin{aligned}-(-3 \text{ V})(3 \text{ A})+(3 \text{ V})(2 \text{ A})+ (3 \text{ V})(2 \text{ A})+(4 \text{ V})(3 \text{ A})+(-3 \text{ V})(-3 \text{ A})+(4 \text{ V})(-3 \text{ A}) \\ = -9 \text{ W} + 6 \text{ W} + 6 \text{ W} + 12 \text{ W} + 9 \text{ W} -12 \text{ W} \\ \neq 0 \text{ W}\end{aligned}$$

The element voltages and currents do not satisfy conservation of energy and cannot be correct.

Design Problems

DP 1-1

The voltage may be as large as $20(1.25) = 25 \text{ V}$ and the current may be as large as $(0.008)(1.25) = 0.01 \text{ A}$. The element needs to be able to absorb $(25 \text{ V})(0.01 \text{ A}) = 0.25 \text{ W}$ continuously. A Grade B element is adequate, but without margin for error. Specify a Grade B device if you trust the estimates of the maximum voltage and current and a Grade A device otherwise.

DP1-2

$$p(t) = 20(1 - e^{-8t}) \times 0.03e^{-8t} = 0.6(1 - e^{-8t})e^{-8t}$$

Here is a MATLAB program to plot $p(t)$:

```
clear

t0=0;           % initial time
tf=1;           % final time
dt=0.02;        % time increment
t=t0:dt:tf;     % time

v=20*(1-exp(-8*t)); % device voltage
i=.030*exp(-8*t);   % device current

for k=1:length(t)
    p(k)=v(k)*i(k); % power
end

plot(t,p)
xlabel('time, s');
ylabel('power, W')
```

Here is the plot:

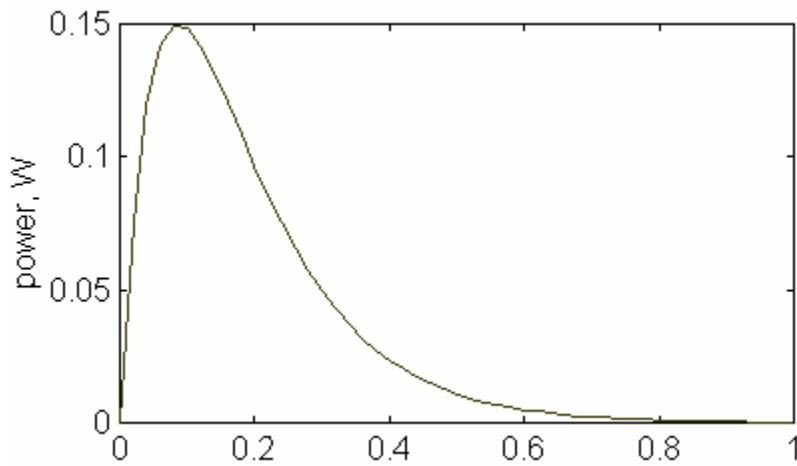

The circuit element must be able to absorb 0.15 W.

Chapter 2 - Circuit Elements

Exercises

Ex. 2.3-1

$$m(i_1 + i_2) = mi_1 + mi_2 \Rightarrow \text{superposition is satisfied}$$

$$m(ai_1) = a(mi_1) \Rightarrow \text{homogeneity is satisfied}$$

Therefore the element is linear.

Ex. 2.3-2

$$m(i_1 + i_2) + b = mi_1 + mi_2 + b \neq (mi_1 + b) + (mi_2 + b) \Rightarrow \text{superposition is not satisfied}$$

Therefore the element is not linear.

Ex. 2.5-1

$$P = \frac{v^2}{R} = \frac{(10)^2}{100} = \underline{1 \text{ W}}$$

Ex. 2.5-2

$$P = \frac{v^2}{R} = \frac{(10 \cos t)^2}{10} = \underline{10 \cos^2 t \text{ W}}$$

Ex. 2.8-1

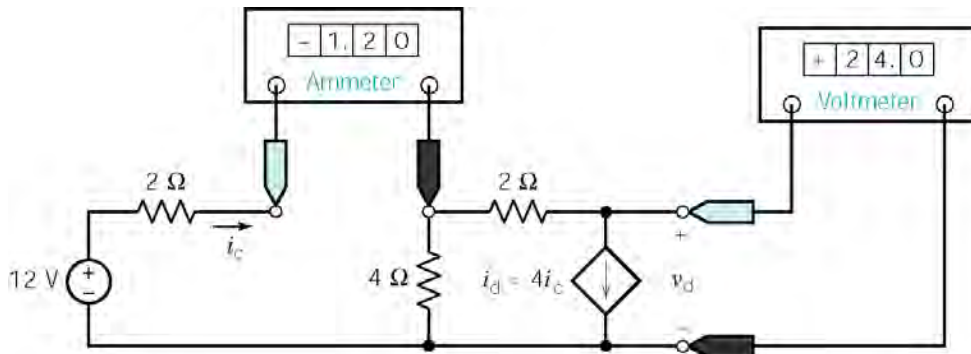

$$i_c = -1.2 \text{ A}, v_d = 24 \text{ V}$$

$$i_d = 4(-1.2) = -4.8 \text{ A}$$

i_d and v_d adhere to the passive convention so

$$P = v_d i_d = (24)(-4.8) = \underline{-115.2 \text{ W}}$$

is the power received by the dependent source

Ex. 2.8-2

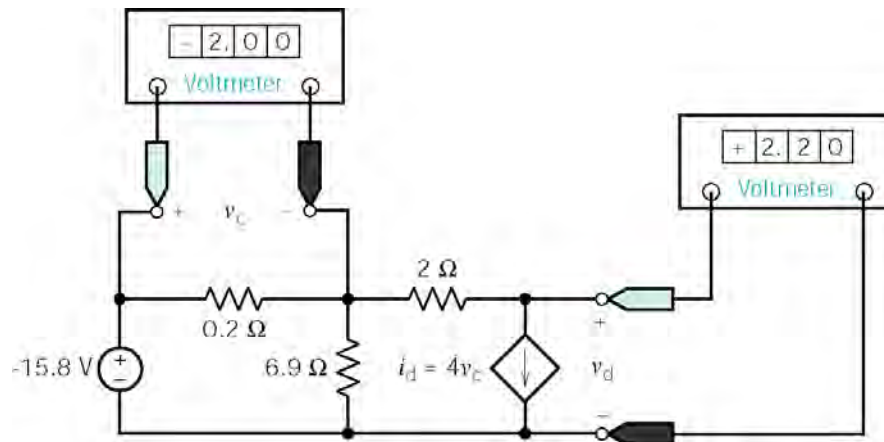

$$v_c = -2 \text{ V}, i_d = 4v_c = -8 \text{ A} \text{ and } v_d = 2.2 \text{ V}$$

i_d and v_d adhere to the passive convention so

$$P = v_d i_d = (2.2)(-8) = \underline{-17.6 \text{ W}}$$

is the power received by the dependent source. The power supplied by the dependent source is 17.6 W.

Ex. 2.8-3

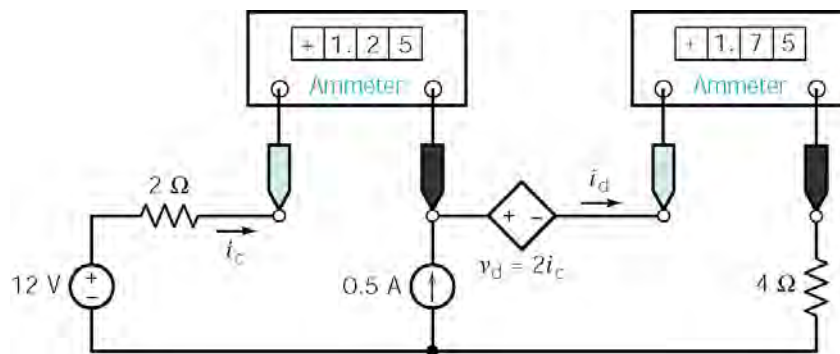

$$i_c = 1.25 \text{ A}, v_d = 2i_c = 2.5 \text{ V} \text{ and } i_d = 1.75 \text{ A}$$

i_d and v_d adhere to the passive convention so

$$P = v_d i_d = (2.5)(1.75) = \underline{4.375 \text{ W}}$$

is the power received by the dependent source.

Ex. 2.9-1

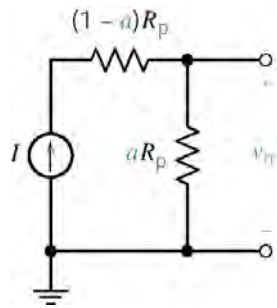

$$\theta = 45^\circ, I = 2 \text{ mA}, R_p = 20 \text{ k}\Omega$$

$$a = \frac{\theta}{360} \Rightarrow a R_p = \frac{45}{360} (20 \text{ k}\Omega) = 2.5 \text{ k}\Omega$$

$$v_m = (2 \times 10^{-3})(2.5 \times 10^3) = \underline{5 \text{ V}}$$

Ex. 2.9-2

$$v = 10 \text{ V}, i = 280 \mu\text{A}, k = 1 \frac{\mu\text{A}}{\text{K}} \text{ for AD590}$$

$$i = kT \Rightarrow T = \frac{i}{k} = (280 \mu\text{A}) \left(1 \frac{\text{K}}{\mu\text{A}} \right) = \underline{280^\circ \text{ K}}$$

Ex. 2.10-1

At $t = 4 \text{ s}$ both switches are open, so $i = 0 \text{ A}$.

Ex. 2.10.2

At $t = 4 \text{ s}$ the switch is in the up position, so $v = iR = (2 \text{ mA})(3 \text{ k}\Omega) = \underline{6 \text{ V}}$.

At $t = 6 \text{ s}$ the switch is in the down position, so $v = 0 \text{ V}$.

Problems

Section 2-3 Engineering and Linear Models

P2.3-1

The element is not linear. For example, doubling the current from 2 A to 4 A does not double the voltage. Hence, the property of homogeneity is not satisfied.

P2.3-2

(a) The data points do indeed lie on a straight line. The slope of the line is 0.12 V/A and the line passes through the origin so the equation of the line is $v = 0.12i$. The element is indeed linear.

(b) When $i = 40 \text{ mA}$, $v = (0.12 \text{ V/A}) \times (40 \text{ mA}) = (0.12 \text{ V/A}) \times (0.04 \text{ A}) = 4.8 \text{ mV}$

(c) When $v = 4 \text{ V}$, $i = \frac{4}{0.12} = 33 \text{ A} = 33 \text{ A}$.

P2.3-3

(a) The data points do indeed lie on a straight line. The slope of the line is 256.5 V/A and the line passes through the origin so the equation of the line is $v = 256.5 i$. The element is indeed linear.

(b) When $i = 4$ mA, $v = (256.5 \text{ V/A}) \times (4 \text{ mA}) = (256.5 \text{ V/A}) \times (0.004 \text{ A}) = 1.026 \text{ V}$

(c) When $v = 12$ V, $i = \frac{12}{256.5} = 0.04678 \text{ A} = 46.78 \text{ mA}$.

P2.3-4

Let $i = 1$ A, then $v = 3i + 5 = 8$ V. Next $2i = 2$ A but $16 = 2v \neq 3(2i) + 5 = 11$. Hence, the property of homogeneity is not satisfied. The element is not linear.

Section 2-5 Resistors

P2.5-1

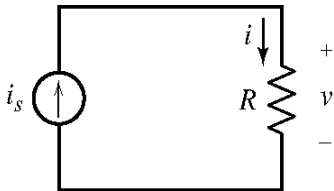

$$i = i_s = 3 \text{ A and } v = Ri = 7 \times 3 = \underline{21 \text{ V}}$$

v and i adhere to the passive convention

$$\therefore P = vi = 21 \times 3 = \underline{63 \text{ W}}$$

is the power absorbed by the resistor.

P2.5-2

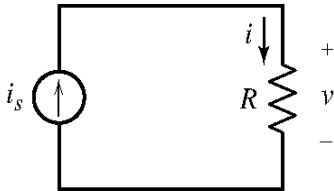

$$i = i_s = 3 \text{ mA and } v = 24 \text{ V}$$

$$R = \frac{v}{i} = \frac{24}{.003} = 8000 = \underline{8 \text{ k}\Omega}$$

$$P = (3 \times 10^{-3}) \times 24 = 72 \times 10^{-3} = \underline{72 \text{ mW}}$$

P2.5-3

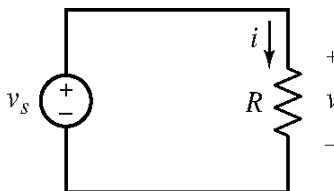

$$v = v_s = 10 \text{ V and } R = 5 \Omega$$

$$i = \frac{v}{R} = \frac{10}{5} = \underline{2 \text{ A}}$$

v and i adhere to the passive convention

$$\therefore p = vi = 2 \cdot 10 = \underline{20 \text{ W}}$$

is the power absorbed by the resistor

P2.5-4

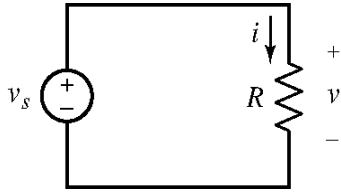

$$v = v_s = 24 \text{ V and } i = 2 \text{ A}$$

$$R = \frac{v}{i} = \frac{24}{2} = \underline{12 \text{ } \Omega}$$

$$p = vi = 24 \cdot 2 = \underline{48 \text{ W}}$$

P2.5-5

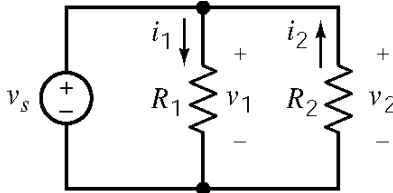

$$v_1 = v_2 = v_s = 150 \text{ V};$$

$$R_1 = 50 \text{ } \Omega; R_2 = 25 \text{ } \Omega$$

v_1 and i_1 adhere to the passive convention so

$$i_1 = \frac{v_1}{R_1} = \frac{150}{50} = \underline{3 \text{ A}}$$

v_2 and i_2 do not adhere to the passive convention so $i_2 = -\frac{v_2}{R_2} = -\frac{150}{25} = \underline{-6 \text{ A}}$

The power absorbed by R_1 is $P_1 = v_1 i_1 = 150 \cdot 3 = \underline{450 \text{ W}}$

The power absorbed by R_2 is $P_2 = -v_2 i_2 = -150(-6) = \underline{900 \text{ W}}$

P2.5-6

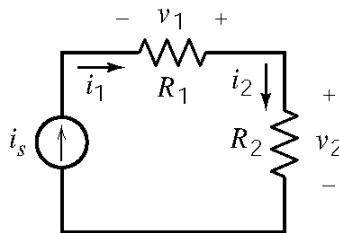

$$i_1 = i_2 = i_s = 2 \text{ A};$$

$$R_1 = 4 \text{ } \Omega \text{ and } R_2 = 8 \text{ } \Omega$$

v_1 and i_1 do not adhere to the passive convention so

$$v_1 = -R_1 i_1 = -4 \cdot 2 = \underline{-8 \text{ V.}}$$

The power absorbed by R_1 is

$$P_1 = -v_1 i_1 = -(-8)(2) = \underline{16 \text{ W.}}$$

v_2 and i_2 do adhere to the passive convention so $v_2 = R_2 i_2 = 8 \cdot 2 = \underline{16 \text{ V.}}$

The power absorbed by R_2 is $P_2 = v_2 i_2 = 16 \cdot 2 = \underline{32 \text{ W.}}$

P2.5-7

Model the heater as a resistor, then

with a 250 V source: $P = \frac{v^2}{R} \Rightarrow R = \frac{v^2}{P} = \frac{(250)^2}{1000} = \underline{62.5 \text{ } \Omega}$

with a 210 V source: $P = \frac{v^2}{R} = \frac{(210)^2}{62.5} = \underline{705.6 \text{ W}}$

P2.5-8

The current required by the mine lights is: $i = \frac{P}{v} = \frac{5000}{120} = \frac{125}{3}$ A

Power loss in the wire is : $i^2 R$

Thus the maximum resistance of the copper wire allowed is

$$R = \frac{0.05P}{i^2} = \frac{0.05 \times 5000}{(125/3)^2} = 0.144 \Omega$$

now since the length of the wire is $L = 2 \times 100 = 200$ m = 20,000 cm

thus $R = \rho L / A$ with $\rho = 1.7 \times 10^{-6} \Omega \cdot \text{cm}$ from Table 2.5-1

$$A = \frac{\rho L}{R} = \frac{1.7 \times 10^{-6} \times 20,000}{0.144} = \underline{0.236 \text{ cm}^2}$$

Section 2-6 Independent Sources**P2.6-1**

(a) $i = \frac{v_s}{R} = \frac{15}{5} = \underline{3 \text{ A}}$ and $P = R i^2 = 5 (3)^2 = \underline{45 \text{ W}}$

(b) i and P do not depend on i_s .

The values of i and P are 3 A and 45 W, both when $i_s = 3$ A and when $i_s = 5$ A.

P2.6-2

(a) $v = R i_s = 5 \cdot 2 = \underline{10 \text{ V}}$ and $P = \frac{v^2}{R} = \frac{10^2}{5} = \underline{20 \text{ W}}$

(b) v and P do not depend on v_s .

The values of v and P are 10V and 20 W both when $v_s = 10$ V and when $v_s = 5$ V

P2.6-3

Consider the current source:

i_s and v_s do not adhere to the passive convention,

$$\text{so } P_{cs} = i_s v_s = 3 \cdot 12 = \underline{36 \text{ W}}$$

is the power supplied by the current source.

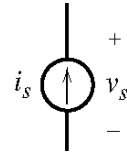

Consider the voltage source:

i_s and v_s do adhere to the passive convention,

$$\text{so } P_{vs} = i_s v_s = 3 \cdot 12 = \underline{36 \text{ W}}$$

is the power absorbed by the voltage source.

\therefore The voltage source supplies -36 W .

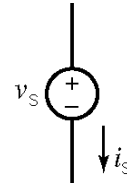
**P2.6-4**

Consider the current source:

i_s and v_s adhere to the passive convention

$$\text{so } P_{cs} = i_s v_s = 3 \cdot 12 = \underline{36 \text{ W}}$$

is the power absorbed by the current source.

Current source supplies -36 W .

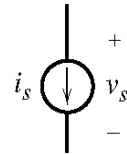

Consider the voltage source:

i_s and v_s do not adhere to the passive convention

$$\text{so } P_{vs} = i_s v_s = 3 \cdot 12 = \underline{36 \text{ W}}$$

is the power supplied by the voltage source.

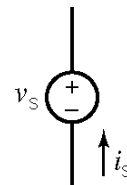
**P2.6-5**

$$(a) P = v i = (2 \cos t) (10 \cos t) = \underline{20 \cos^2 t \text{ mW}}$$

$$(b) w = \int_0^1 P dt = \int_0^1 20 \cos^2 t dt = 20 \left(\frac{1}{2} t + \frac{1}{4} \sin 2t \right) \Big|_0^1 = \underline{10 + 5 \sin 2 \text{ mJ}}$$

Section 2-7 Voltmeters and Ammeters

P2.7-1

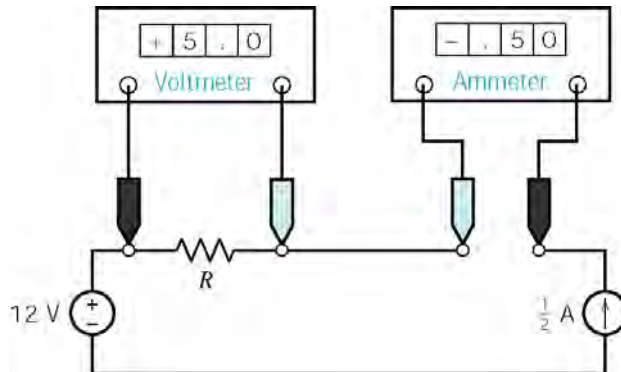

$$(a) R = \frac{v}{i} = \frac{5}{0.5} = 10 \Omega$$

(b) The voltage, 12 V, and the current, 0.5 A, of the voltage source adhere to the passive convention so the power

$$P = 12 (0.5) = 6 \text{ W}$$

is the power received by the source. The voltage source delivers -6 W.

P2.7-2

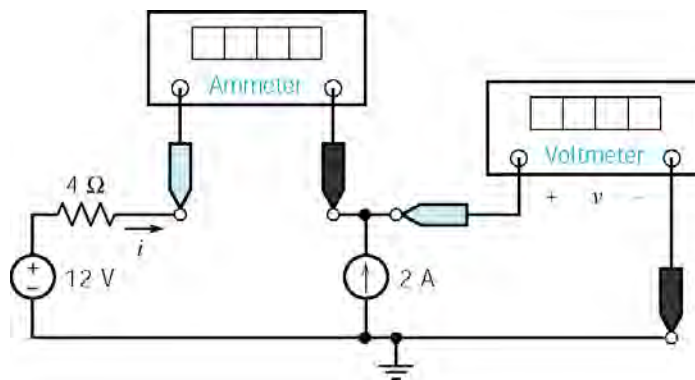

The voltmeter current is zero so the ammeter current is equal to the current source current except for the reference direction:

$$i = -2 \text{ A}$$

The voltage v is the voltage of the current source. The power supplied by the current source is 40 W so

$$40 = 2 v \Rightarrow v = 20 \text{ V}$$

Section 2-8 Dependent Sources

P2.8-1

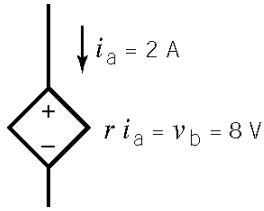

$$r = \frac{v_b}{i_a} = \frac{8}{2} = 4 \, \Omega$$

P2.8-2

$$v_b = 8 \, \text{V}; \quad g v_b = i_a = 2 \, \text{A}; \quad g = \frac{i_a}{v_b} = \frac{2}{8} = 0.25 \, \frac{\text{A}}{\text{V}}$$

P2.8-3

$$i_b = 8 \, \text{A}; \quad d i_b = i_a = 32 \, \text{A}; \quad d = \frac{i_a}{i_b} = \frac{32}{8} = 4 \, \frac{\text{A}}{\text{A}}$$

P2.8-4

$$v_a = 2 \, \text{V}; \quad b v_a = v_b = 8 \, \text{V}; \quad b = \frac{v_b}{v_a} = \frac{8}{2} = 4 \, \frac{\text{V}}{\text{V}}$$

Section 2-9 Transducers

P2.9-1

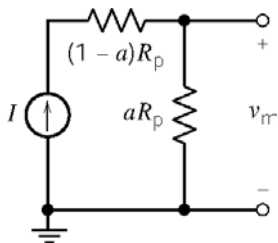

$$a = \frac{\theta}{360}, \quad \theta = \frac{360 v_m}{R_p I}$$

$$\theta = \frac{(360)(23\text{V})}{(100 \, \text{k}\Omega)(1.1 \, \text{mA})} = 75.27^\circ$$

P2.9-2

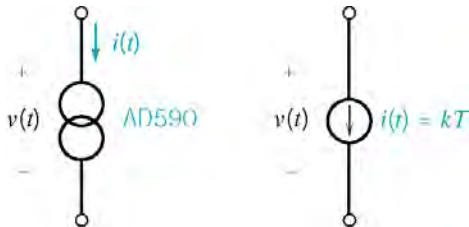

$$\text{AD590} : k = 1 \, \frac{\mu\text{A}}{^\circ\text{K}},$$

$v = 20 \, \text{V}$ (voltage condition satisfied)

$$\left. \begin{array}{l} 4 \, \mu\text{A} < i < 13 \, \mu\text{A} \\ T = \frac{i}{k} \end{array} \right\} \Rightarrow \underline{4^\circ\text{K} < T < 13^\circ\text{K}}$$

Section 2-10 Switches

P2.10-1

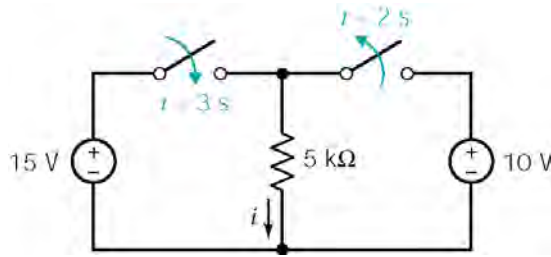

At $t = 1$ s the left switch is open and the right switch is closed so the voltage across the resistor is 10 V.

$$i = \frac{v}{R} = \frac{10}{5 \times 10^3} = \underline{2 \text{ mA}}$$

At $t = 4$ s the left switch is closed and the right switch is open so the voltage across the resistor is 15 V.

$$i = \frac{v}{R} = \frac{15}{5 \times 10^3} = \underline{3 \text{ mA}}$$

P2.10-2

At $t = 1$ s the current in the resistor is 3 mA so $v = 15$ V.

At $t = 4$ s the current in the resistor is 0 A so $v = 0$ V.

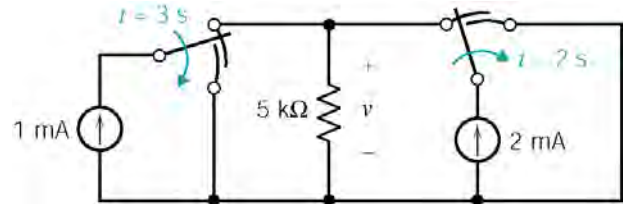

Verification Problems

VP2-1

$v_o = 40$ V and $i_s = -(-2) = 2$ A. (Notice that the ammeter measures $-i_s$ rather than i_s .)

$$\text{So } \frac{v_o}{i_s} = \frac{40}{2} = 20 \frac{\text{V}}{\text{A}}$$

Your lab partner is wrong.

VP2-2

We expect the resistor current to be $i = \frac{v_s}{R} = \frac{12}{25} = 0.48$ A. The power absorbed by this resistor will be $P = i v_s = (0.48)(12) = 5.76$ W.

A half watt resistor can't absorb this much power. You should not try another resistor.

Design Problems

DP2-1

$$1.) \frac{10}{R} > 0.04 \Rightarrow R < \frac{10}{0.04} = 250 \Omega$$

$$2.) \frac{10^2}{R} < \frac{1}{2} \Rightarrow R > 200 \Omega$$

Therefore $200 < R < 250 \Omega$. For example, $R = 225 \Omega$.

DP2-2

$$1.) 2R > 40 \Rightarrow R > 20 \Omega$$

$$2.) 2^2 R < 15 \Rightarrow R < \frac{15}{4} = 3.75 \Omega$$

Therefore $20 < R < 3.75 \Omega$. These conditions cannot be satisfied simultaneously.

DP2-3

$$P_1 = (30 \text{ mA})^2 \cdot (1000 \Omega) = (.03)^2 (1000) = 0.9 \text{ W} < 1 \text{ W}$$

$$P_2 = (30 \text{ mA})^2 \cdot (2000 \Omega) = (.03)^2 (2000) = 1.8 \text{ W} < 2 \text{ W}$$

$$P_3 = (30 \text{ mA})^2 \cdot (4000 \Omega) = (.03)^2 (4000) = 3.6 \text{ W} < 4 \text{ W}$$

Chapter 3 – Resistive Circuits

Exercises

Ex 3.3-1

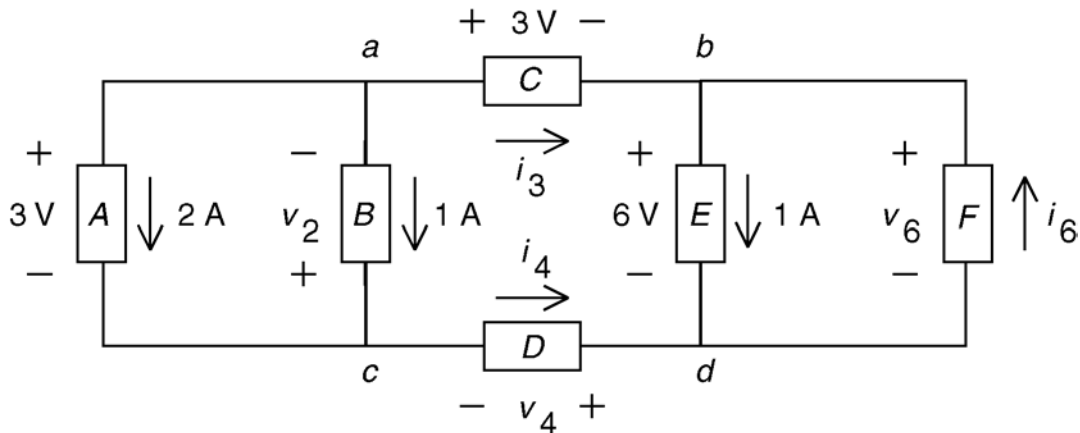

Apply KCL at node a to get $2 + 1 + i_3 = 0 \Rightarrow i_3 = -3 \text{ A}$

Apply KCL at node c to get $2 + 1 = i_4 \Rightarrow i_4 = 3 \text{ A}$

Apply KCL at node b to get $i_3 + i_6 = 1 \Rightarrow -3 + i_6 = 1 \Rightarrow i_6 = 4 \text{ A}$

Apply KVL to the loop consisting of elements A and B to get

$$-v_2 - 3 = 0 \Rightarrow v_2 = -3 \text{ V}$$

Apply KVL to the loop consisting of elements C , E , D , and A to get

$$3 + 6 + v_4 - 3 = 0 \Rightarrow v_4 = -6 \text{ V}$$

Apply KVL to the loop consisting of elements E and F to get

$$v_6 - 6 = 0 \Rightarrow v_6 = 6 \text{ V}$$

Check: The sum of the power supplied by all branches is

$$-(3)(2) + (-3)(1) - (3)(-3) + (-6)(3) - (6)(1) + (6)(4) = -6 - 3 + 9 - 18 - 6 + 24 = 0$$

Ex 3.3-2

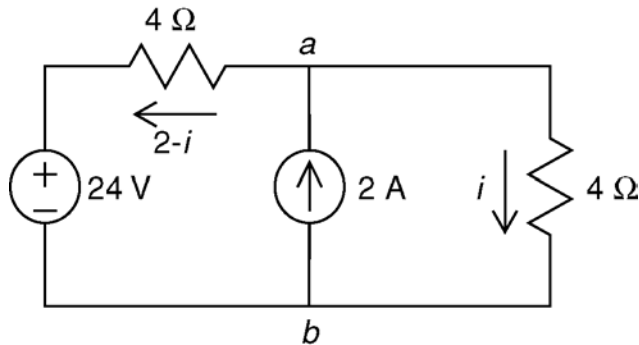

Apply KCL at node a to determine the current in the horizontal resistor as shown.

Apply KVL to the loop consisting of the voltage source and the two resistors to get

$$-4(2-i) + 4(i) - 24 = 0 \Rightarrow i = 4 \text{ A}$$

Ex 3.3-3

$$-18 + 0 - 12 - v_a = 0 \Rightarrow v_a = -30 \text{ V} \quad \text{and} \quad i_m = \frac{2}{5}v_a + 3 \Rightarrow i_m = 9 \text{ A}$$

Ex 3.3-4

$$-v_a - 10 + 4v_a - 8 = 0 \Rightarrow v_a = \frac{18}{3} = 6 \text{ V} \quad \text{and} \quad v_m = 4v_a = 24 \text{ V}$$

Ex 3.4-1

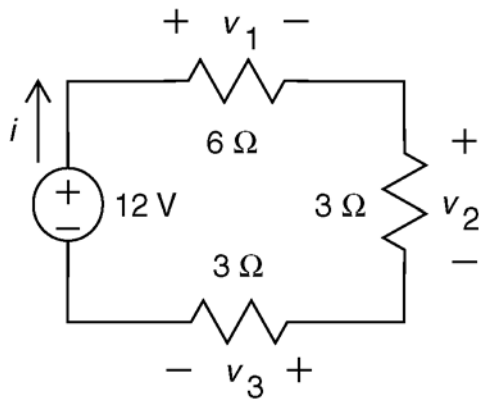

From voltage division

$$v_3 = 12 \left(\frac{3}{3+9} \right) = \underline{3\text{V}}$$

then

$$i = \frac{v_3}{3} = \underline{1\text{A}}$$

The power absorbed by the resistors is: $(1^2)(6) + (1^2)(3) + (1^2)(3) = 12 \text{ W}$

The power supplied by the source is $(12)(1) = 12 \text{ W}$.

Ex 3.4-2

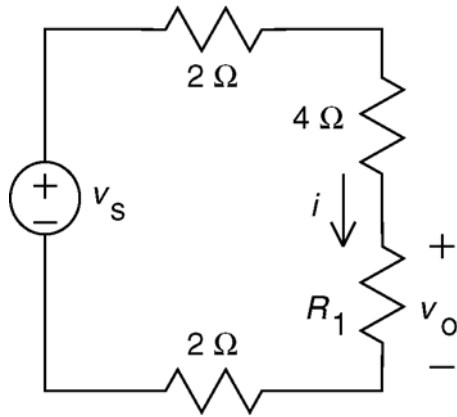

$$P = 6 \text{ W and } R_1 = 6 \Omega$$

$$i^2 = \frac{P}{R_1} = \frac{6}{6} = 1 \text{ or } i = 1 \text{ A}$$

$$v_o = i R_1 = (1)(6) = \underline{6\text{V}}$$

$$\text{from KVL: } -v_s + i(2+4+6+2) = 0$$

$$\Rightarrow \underline{v_s = 14i = 14 \text{ V}}$$

Ex 3.4-3 From voltage division $\Rightarrow v_m = \frac{25}{25+75}(8) = 2 \text{ V}$

Ex 3.4-4 From voltage division $\Rightarrow v_m = \frac{25}{25+75}(-8) = -2 \text{ V}$

Ex. 3.5-1

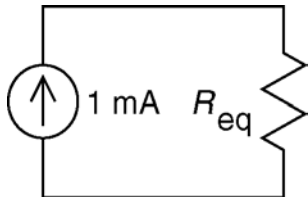

$$\frac{1}{R_{eq}} = \frac{1}{10^3} + \frac{1}{10^3} + \frac{1}{10^3} + \frac{1}{10^3} = \frac{4}{10^3} \Rightarrow R_{eq} = \frac{10^3}{4} = \underline{\frac{1}{4} \text{ k}\Omega}$$

$$\text{By current division, the current in each resistor} = \frac{1}{4}(10^{-3}) = \underline{\frac{1}{4} \text{ mA}}$$

Ex 3.5-2

$$\text{From current division } \Rightarrow i_m = \frac{10}{10+40}(-5) = -1 \text{ A}$$

Problems

Section 3-3 Kirchoff's Laws

P3.3-1

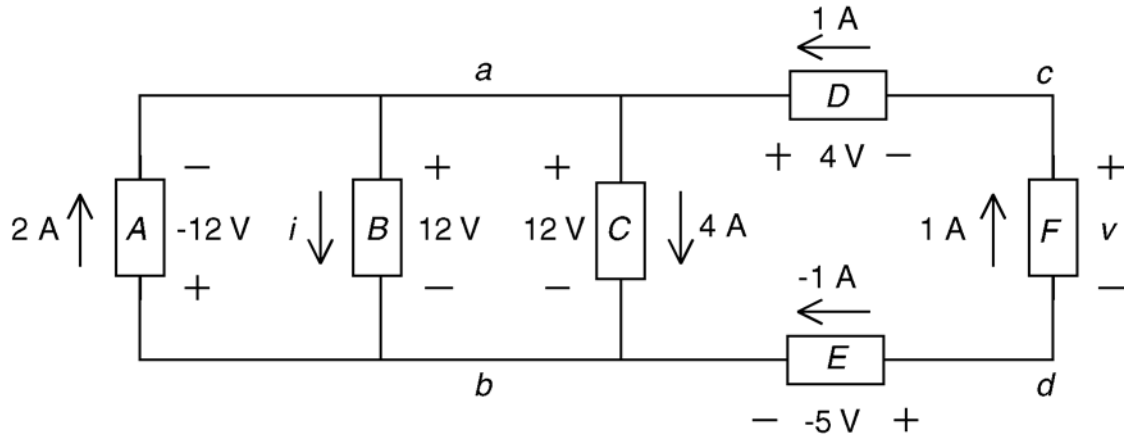

Apply KCL at node a to get $2 + 1 = i + 4 \Rightarrow i = -1 \text{ A}$

The current and voltage of element B adhere to the passive convention so $(12)(-1) = -12 \text{ W}$ is power received by element B . The power supplied by element B is 12 W.

Apply KVL to the loop consisting of elements D , F , E , and C to get

$$4 + v + (-5) - 12 = 0 \Rightarrow v = 13 \text{ V}$$

The current and voltage of element F do not adhere to the passive convention so $(13)(1) = 13 \text{ W}$ is the power supplied by element F .

Check: The sum of the power supplied by all branches is

$$-(2)(-12) + \underline{12} - (4)(12) + (1)(4) + \underline{13} - (-1)(-5) = 24 + 12 - 48 + 4 + 13 - 5 = 0$$

P3.3-2

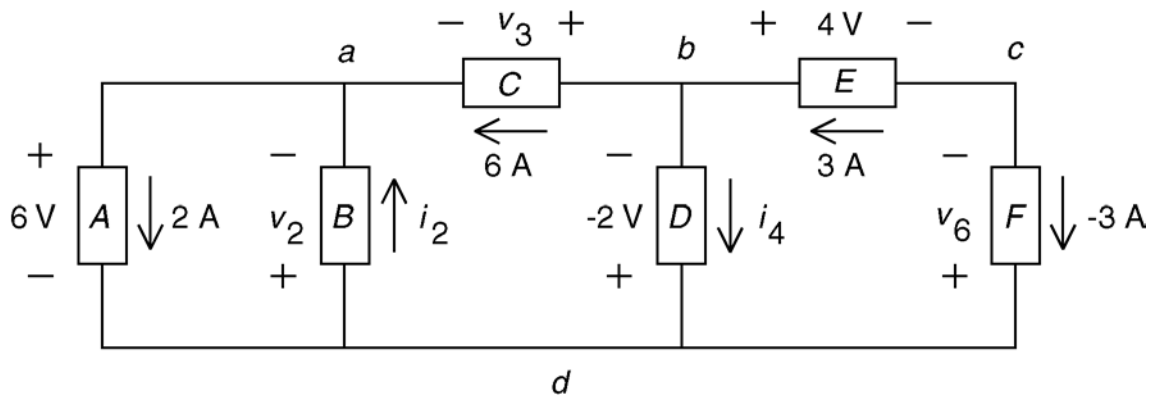

Apply KCL at node a to get $2 = i_2 + 6 = 0 \Rightarrow i_2 = -4 \text{ A}$

Apply KCL at node b to get $3 = i_4 + 6 \Rightarrow i_4 = -3 \text{ A}$

Apply KVL to the loop consisting of elements A and B to get

$$-v_2 - 6 = 0 \Rightarrow v_2 = -6 \text{ V}$$

Apply KVL to the loop consisting of elements C , D , and A to get

$$-v_3 - (-2) - 6 = 0 \Rightarrow v_3 = -4 \text{ V}$$

Apply KVL to the loop consisting of elements E , F and D to get

$$4 - v_6 + (-2) = 0 \Rightarrow v_6 = 2 \text{ V}$$

Check: The sum of the power supplied by all branches is

$$-(6)(2) - (-6)(-4) - (-4)(6) + (-2)(-3) + (4)(3) + (2)(-3) = -12 - 24 + 24 + 6 + 12 - 6 = 0$$

P3.3-3

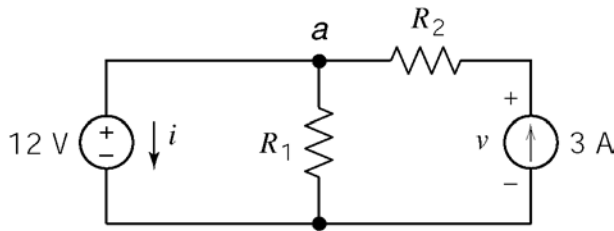

KVL : $-12 - R_2(3) + v = 0$ (outside loop)

$$v = 12 + 3R_2 \text{ or } R_2 = \frac{v-12}{3}$$

KCL $i + \frac{12}{R_1} - 3 = 0$ (top node)

$$i = 3 - \frac{12}{R_1} \text{ or } R_1 = \frac{12}{3-i}$$

(a)

$$v = 12 + 3(3) = 21 \text{ V}$$

$$i = 3 - \frac{12}{6} = 1 \text{ A}$$

(b)

$$R_2 = \frac{2-12}{3} = \underline{\underline{-\frac{10}{3} \Omega}} ; R_1 = \frac{12}{3-1.5} = \underline{\underline{8 \Omega}}$$

(checked using LNAP 8/16/02)

(c)

$$24 = -12 i, \text{ because } 12 \text{ and } i \text{ adhere to the passive convention.}$$

$$\therefore \underline{\underline{i = -2 \text{ A}}} \text{ and } R_1 = \frac{12}{3+2} = \underline{\underline{2.4 \Omega}}$$

$$9 = 3v, \text{ because } 3 \text{ and } v \text{ do not adhere to the passive convention}$$

$$\therefore \underline{\underline{v = 3 \text{ V}}} \text{ and } R_2 = \frac{3-12}{3} = \underline{\underline{-3 \Omega}}$$

The situations described in (b) and (c) cannot occur if R_1 and R_2 are required to be nonnegative.

P3.3-4

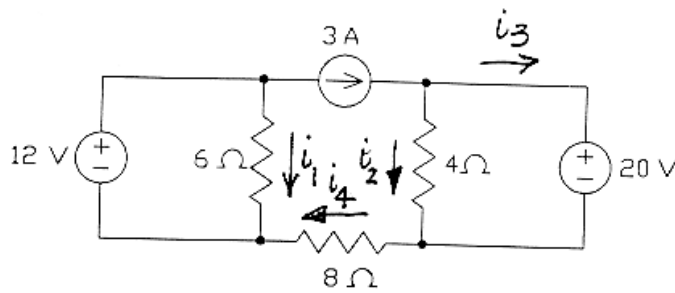

$$i_1 = \frac{12}{6} = 2 \text{ A}$$

$$i_2 = \frac{20}{4} = 5 \text{ A}$$

$$i_3 = 3 - i_2 = -2 \text{ A}$$

$$i_4 = i_2 + i_3 = 3 \text{ A}$$

Power absorbed by the 4 Ω resistor = $4 \cdot i_2^2 = \underline{100 \text{ W}}$

Power absorbed by the 6 Ω resistor = $6 \cdot i_1^2 = \underline{24 \text{ W}}$

Power absorbed by the 8 Ω resistor = $8 \cdot i_4^2 = \underline{72 \text{ W}}$

(checked using LNAP 8/16/02)

P3.3-5

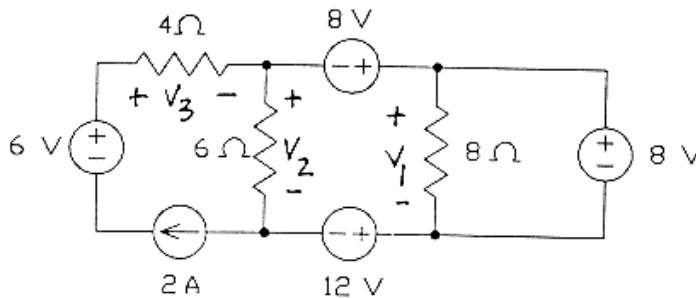

$$v_1 = 8 \text{ V}$$

$$v_2 = -8 + 8 + 12 = 12 \text{ V}$$

$$v_3 = 2 \cdot 4 = 8 \text{ V}$$

$$4\Omega: P = \frac{v_3^2}{4} = \underline{16 \text{ W}}$$

$$6\Omega: P = \frac{v_2^2}{6} = \underline{24 \text{ W}}$$

$$8\Omega: P = \frac{v_1^2}{8} = \underline{8 \text{ W}}$$

(checked using LNAP 8/16/02)

P3.3-6

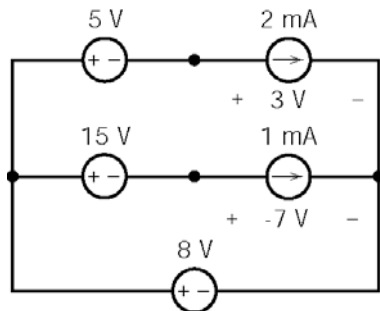

$$P_{2\text{mA}} = -[3 \times (2 \times 10^{-3})] = -6 \times 10^{-3} = -6 \text{ mW}$$

$$P_{1\text{mA}} = -[-7 \times (1 \times 10^{-3})] = 7 \times 10^{-3} = 7 \text{ mW}$$

(checked using LNAP 8/16/02)

P3.3-7

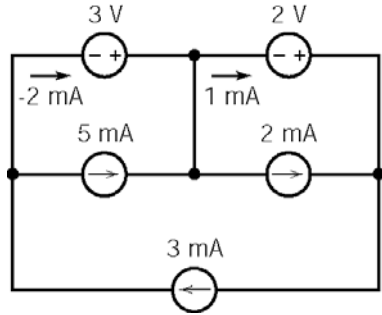

$$P_{2V} = +[2 \times (1 \times 10^{-3})] = 2 \times 10^{-3} = 2 \text{ mW}$$

$$P_{3V} = +[3 \times (-2 \times 10^{-3})] = -6 \times 10^{-3} = -6 \text{ mW}$$

(checked using LNAP 8/16/02)

P3.3-8

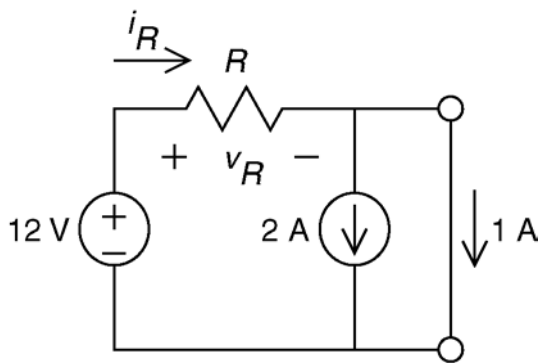

$$\text{KCL: } i_R = 2 + 1 \Rightarrow i_R = 3 \text{ A}$$

$$\text{KVL: } v_R + 0 - 12 = 0 \Rightarrow v_R = 12 \text{ V}$$

$$\therefore R = \frac{v_R}{i_R} = \frac{12}{3} = 4 \Omega$$

(checked using LNAP 8/16/02)

P3.3-9

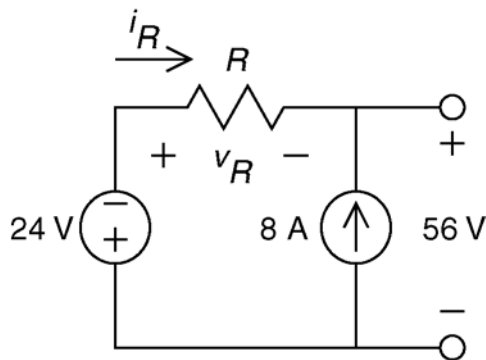

$$\text{KVL: } v_R + 56 + 24 = 0 \Rightarrow v_R = -80 \text{ V}$$

$$\text{KCL: } i_R + 8 = 0 \Rightarrow i_R = -8 \text{ A}$$

$$\therefore R = \frac{v_R}{i_R} = \frac{-80}{-8} = 10 \Omega$$

(checked using LNAP 8/16/02)

P3.3-10

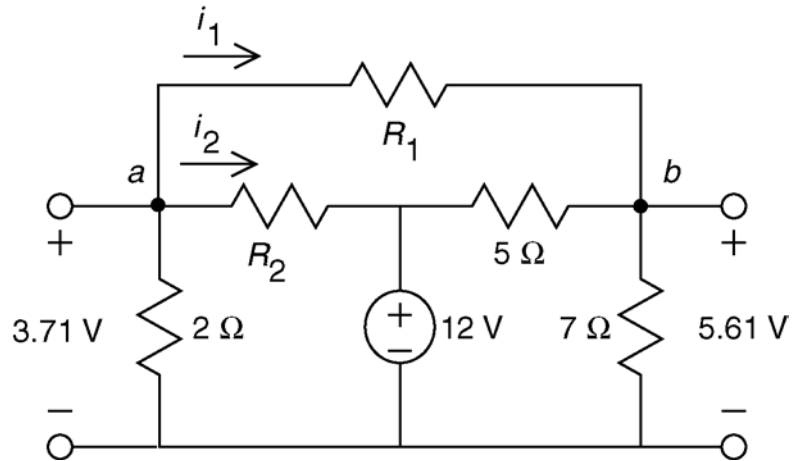

KCL at node b :

$$\frac{5.61}{7} = \frac{3.71 - 5.61}{R_1} + \frac{12 - 5.61}{5} \Rightarrow 0.801 = \frac{-1.9}{R_1} + 1.278$$

$$\Rightarrow R_1 = \frac{1.9}{1.278 - 0.801} = 3.983 \approx 4 \Omega$$

KCL at node a :

$$\frac{3.71}{2} + \frac{3.71 - 5.61}{4} + \frac{3.71 - 12}{R_2} = 0 \Rightarrow 1.855 + (-0.475) + \frac{-8.29}{R_2} = 0$$

$$\Rightarrow R_2 = \frac{8.29}{1.855 - 0.475} = 6.007 \approx 6 \Omega$$

(checked using LNAP 8/16/02)

Section 3-4 A Single-Loop Circuit – The Voltage Divider

P3.4-1

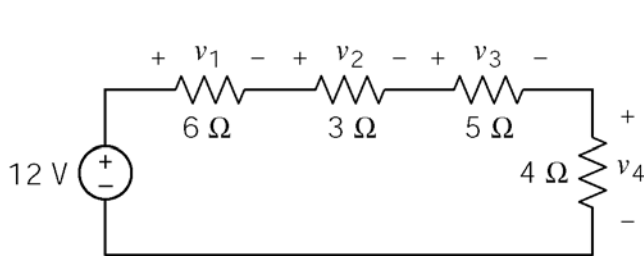

$$v_1 = \frac{6}{6+3+5+4} 12 = \frac{6}{18} 12 = \underline{4 \text{ V}}$$

$$v_2 = \frac{3}{18} 12 = \underline{2 \text{ V}} ; v_3 = \frac{5}{18} 12 = \underline{\frac{10}{3} \text{ V}}$$

$$v_4 = \frac{4}{18} 12 = \underline{\frac{8}{3} \text{ V}}$$

(checked using LNAP 8/16/02)

P3.4-2

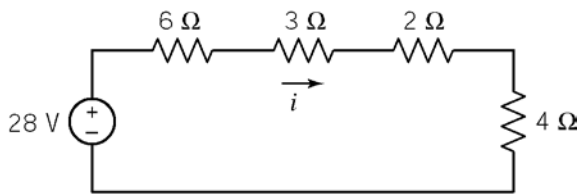

(a)

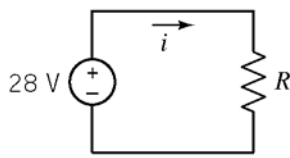

(b)

(a) $R = 6 + 3 + 2 + 4 = \underline{15 \Omega}$

(b) $i = \frac{28}{R} = \frac{28}{15} = \underline{1.867 \text{ A}}$

(c) $p = 28 \cdot i = 28(1.867) = \underline{52.27 \text{ W}}$

(28 V and i do not adhere to the passive convention.)

(checked using LNAP 8/16/02)

P3.4-3

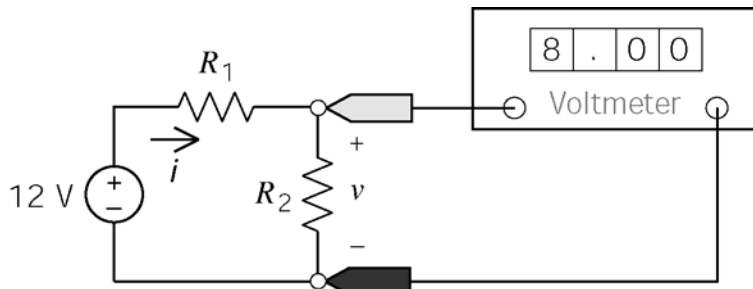

$$i R_2 = v = 8 \text{ V}$$

$$12 = i R_1 + v = i R_1 + 8$$

$$\Rightarrow 4 = i R_1$$

(a) $i = \frac{8}{R_2} = \frac{8}{100}$; $R_1 = \frac{4}{i} = \frac{4 \cdot 100}{8} = \underline{50 \Omega}$

(b) $i = \frac{4}{R_1} = \frac{4}{100}$; $R_2 = \frac{8}{i} = \frac{8 \cdot 100}{4} = \underline{200 \Omega}$

(c) $1.2 = 12 i \Rightarrow i = 0.1 \text{ A}$; $R_1 = \frac{4}{i} = \underline{40 \Omega}$; $R_2 = \frac{8}{i} = \underline{80 \Omega}$

(checked using LNAP 8/16/02)

P3.4-4

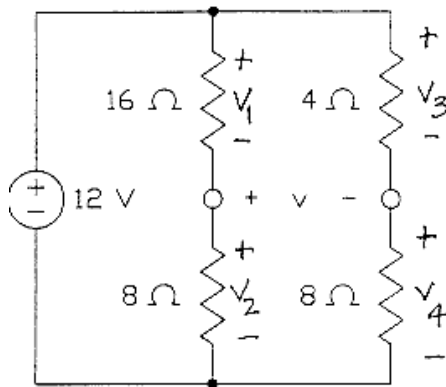

Voltage division

$$v_1 = \frac{16}{16+8} 12 = 8 \text{ V}$$

$$v_3 = \frac{4}{4+8} 12 = 4 \text{ V}$$

KVL: $v_3 - v - v_1 = 0$

$$\underline{v = -4 \text{ V}}$$

(checked using LNAP 8/16/02)

P3.4-5

using voltage divider: $v_0 = \left(\frac{100}{100+2R} \right) v_s \Rightarrow R = 50 \left(\frac{v_s}{v_0} - 1 \right)$

$$\left. \begin{array}{l} \text{with } v_s = 20 \text{ V and } v_0 > 9 \text{ V, } R < 61.1 \Omega \\ \text{with } v_s = 28 \text{ V and } v_0 < 13 \text{ V, } R > 57.7 \Omega \end{array} \right\} \underline{R = 60 \Omega}$$

P3.4-6

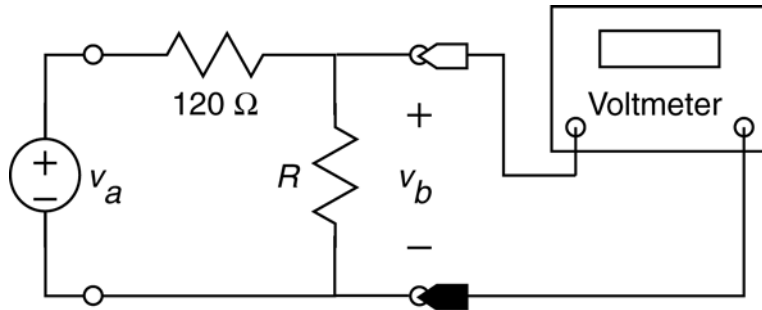

a.) $\left(\frac{240}{120+240}\right)18=12 \text{ V}$

b.) $18\left(\frac{18}{120+240}\right)=0.9 \text{ W}$

c.) $\left(\frac{R}{R+120}\right)18=2 \Rightarrow 18R=2R+2(120) \Rightarrow R=15 \Omega$

d.) $0.2=\frac{R}{R+120} \Rightarrow (0.2)(120)=0.8R \Rightarrow R=30 \Omega$

(checked using LNAP 8/16/02)

Section 3-5 Parallel Resistors and Current Division

P3.5-1

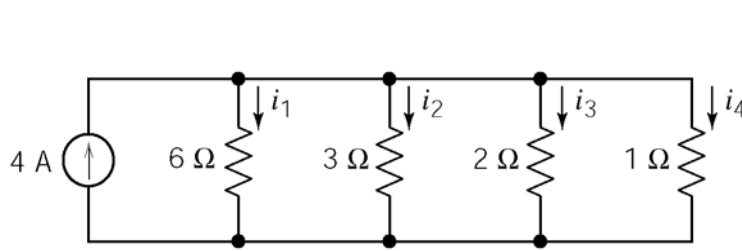

$$i_1 = \frac{\frac{1}{6}}{\frac{1}{6} + \frac{1}{3} + \frac{1}{2} + \frac{1}{1}} 4 = \frac{1}{1+2+3+6} 4 = \underline{\frac{1}{3} \text{ A}}$$

$$i_2 = \frac{\frac{1}{3}}{\frac{1}{6} + \frac{1}{3} + \frac{1}{2} + \frac{1}{1}} 4 = \underline{\frac{2}{3} \text{ A}}$$

$$i_3 = \frac{\frac{1}{2}}{\frac{1}{6} + \frac{1}{3} + \frac{1}{2} + \frac{1}{1}} 4 = \underline{1 \text{ A}}$$

$$i_4 = \frac{1}{\frac{1}{6} + \frac{1}{3} + \frac{1}{2} + \frac{1}{1}} 4 = \underline{2 \text{ A}}$$

P3.5-2

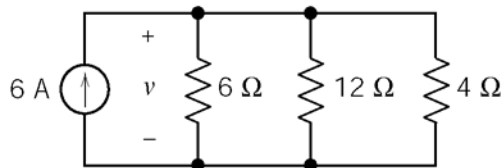

(a)

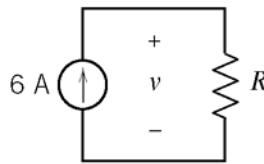

(b)

$$(a) \frac{1}{R} = \frac{1}{6} + \frac{1}{12} + \frac{1}{4} = \frac{1}{2} \Rightarrow R = \underline{2 \Omega}$$

$$(b) v = 6 \cdot 2 = \underline{12 \text{ V}}$$

$$(c) p = 6 \cdot 12 = \underline{72 \text{ W}}$$

P3.5-3

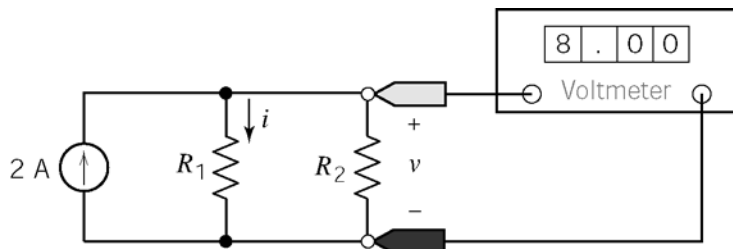

$$i = \frac{8}{R_1} \text{ or } R_1 = \frac{8}{i}$$

$$8 = R_2(2 - i) \Rightarrow i = 2 - \frac{8}{R_2} \text{ or } R_2 = \frac{8}{2 - i}$$

$$(a) i = 2 - \frac{8}{12} = \frac{4}{3} \text{ A} ; R_1 = \frac{8}{4/3} = \underline{6 \Omega}$$

$$(b) i = \frac{8}{12} = \frac{2}{3} \text{ A} ; R_2 = \frac{8}{2 - 2/3} = \underline{6 \Omega}$$

(c) $R_1 = R_2$ will cause $i = \frac{1}{2} \cdot 2 = 1$ A. The current in both R_1 and R_2 will be 1 A.

$$2 \cdot \frac{R_1 R_2}{R_1 + R_2} = 8; \quad R_1 = R_2 \Rightarrow 2 \cdot \frac{1}{2} R_1 = 8 \Rightarrow R_1 = 8 \therefore \underline{R_1 = R_2 = 8 \Omega}$$

P3.5-4

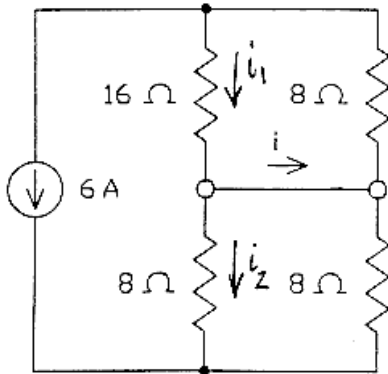

Current division:

$$i_1 = \frac{8}{16+8}(-6) = -2 \text{ A}$$

$$i_2 = \frac{8}{8+8}(-6) = -3 \text{ A}$$

$$i = i_1 - i_2 = +1 \text{ A}$$

P3.5-5

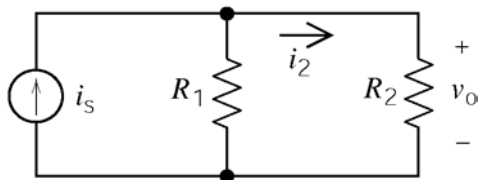

current division: $i_2 = \left(\frac{R_1}{R_1 + R_2} \right) i_s$ and

Ohm's Law: $v_o = i_2 R_2$ yields

$$i_s = \left(\frac{v_o}{R_2} \right) \left(\frac{R_1 + R_2}{R_1} \right)$$

plugging in $R_1 = 4 \Omega$, $v_o > 9$ V gives $i_s > 3.15$ A

and $R_1 = 6 \Omega$, $v_o < 13$ V gives $i_s < 3.47$ A

So any $3.15 \text{ A} < i_s < 3.47 \text{ A}$ keeps $9 \text{ V} < v_o < 13 \text{ V}$.

P3.5-6

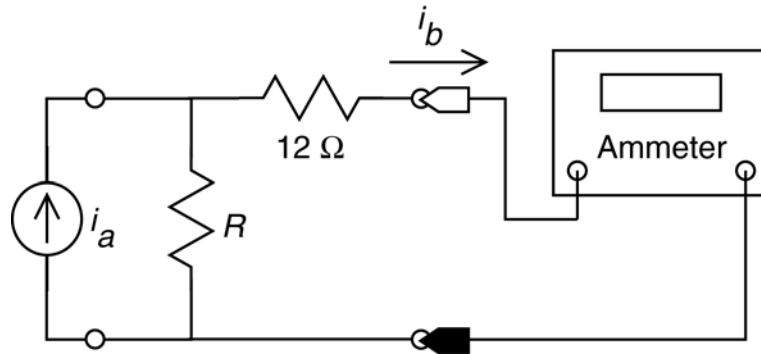

- a) $\left(\frac{24}{12+24}\right)1.8 = 1.2 \text{ A}$
- b) $\left(\frac{R}{R+12}\right)2 = 1.6 \Rightarrow 2R = 1.6R + 1.6(12) \Rightarrow R = 48 \text{ } \Omega$
- c) $0.4 = \frac{R}{R+12} \Rightarrow (0.4)(12) = 0.6R \Rightarrow R = 8 \text{ } \Omega$

Section 3-7 Circuit Analysis

P3.7-1

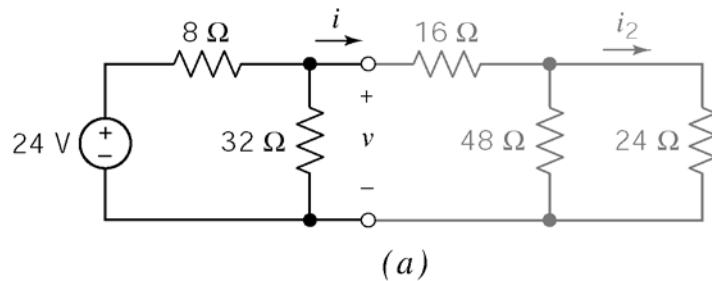

(a) $R = 16 + \frac{48 \cdot 24}{48 + 24} = \underline{32 \text{ } \Omega}$

(b) $v = \frac{\frac{32 \cdot 32}{32 + 32}}{8 + \frac{32 \cdot 32}{32 + 32}} 24 = \underline{16 \text{ V}}$;

$i = \frac{16}{32} = \underline{\frac{1}{2} \text{ A}}$

(c) $i_2 = \frac{48}{48 + 24} \cdot \frac{1}{2} = \underline{\frac{1}{3} \text{ A}}$

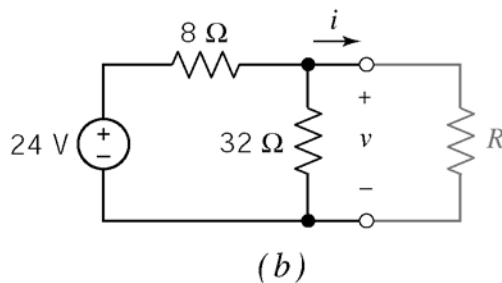

P3.7-2

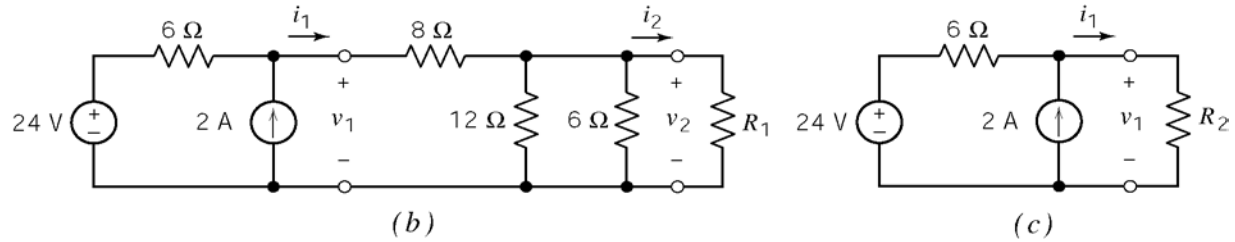
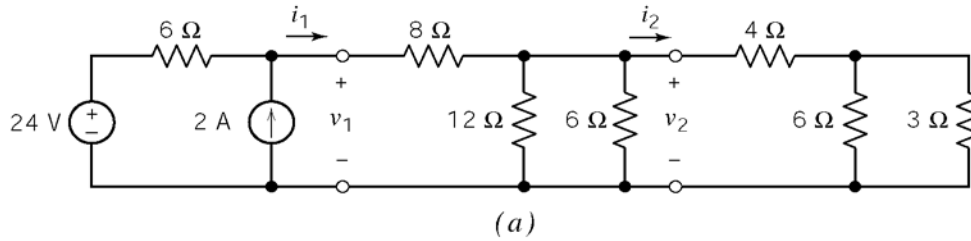

(a) $R_1 = 4 + \frac{3 \cdot 6}{3 + 6} = \underline{6 \Omega}$

(b) $\frac{1}{R_p} = \frac{1}{12} + \frac{1}{6} + \frac{1}{6} \Rightarrow R_p = 2.4 \Omega$ then $R_2 = 8 + R_p = \underline{10.4 \Omega}$

(c) KCL: $i_2 + 2 = i_1$ and $-24 + 6i_2 + R_2i_1 = 0$
 $\Rightarrow -24 + 6(i_1 - 2) + 10.4i_1 = 0$
 $\Rightarrow i_1 = \frac{36}{16.4} = \underline{2.2 \text{ A}} \Rightarrow v_1 = i_1 R_2 = 2.2(10.4) = \underline{22.88 \text{ V}}$

(d) $i_2 = \frac{\frac{1}{6}}{\frac{1}{6} + \frac{1}{6} + \frac{1}{12}}(2.2) = \underline{0.878 \text{ A}}$
 $v_2 = (0.878)(6) = \underline{5.3 \text{ V}}$

(e) $i_3 = \frac{6}{3 + 6}i_2 = 0.585 \text{ A} \Rightarrow P = 3i_3^2 = \underline{1.03 \text{ W}}$

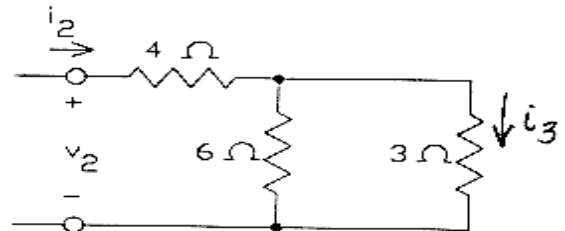

P3.7-3

Reduce the circuit from the right side by repeatedly replacing series 1 Ω resistors in parallel with a 2 Ω resistor by the equivalent 1 Ω resistor

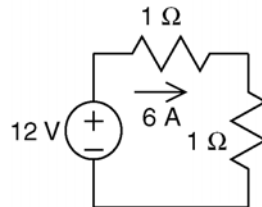
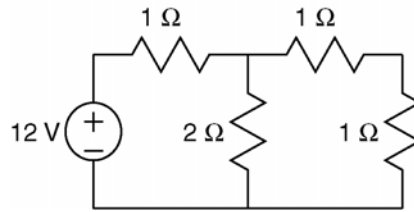
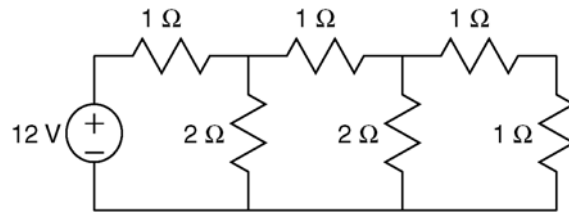

This circuit has become small enough to be easily analyzed. The vertical 1 Ω resistor is equivalent to a 2 Ω resistor connected in parallel with series 1 Ω resistors:

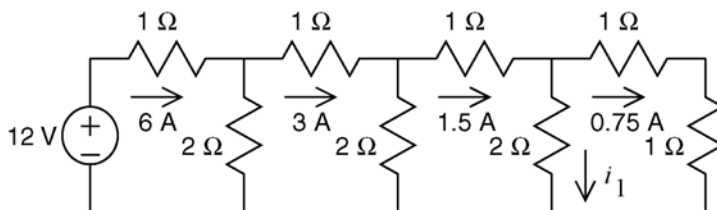
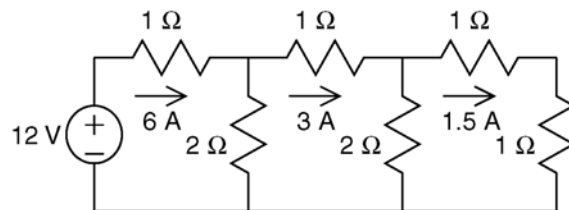
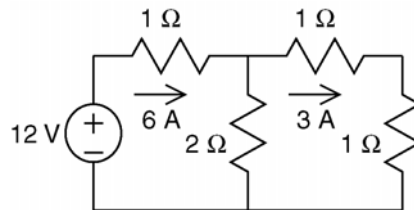

$$i_1 = \frac{1+1}{2+(1+1)}(1.5) = 0.75 \text{ A}$$

P3.7-4

(a)
$$\frac{1}{R_2} = \frac{1}{24} + \frac{1}{12} + \frac{1}{8} \Rightarrow R_2 = 4\Omega \quad \text{and} \quad R_1 = \frac{(10+8) \cdot 9}{(10+8)+9} = 6\Omega$$

(b)

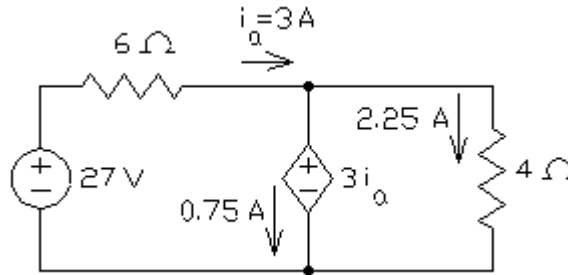

First, apply KVL to the left mesh to get $-27 + 6i_a + 3i_a = 0 \Rightarrow i_a = 3\text{ A}$. Next, apply KVL to the right mesh to get $4i_b - 3i_a = 0 \Rightarrow i_b = 2.25\text{ A}$.

(c)

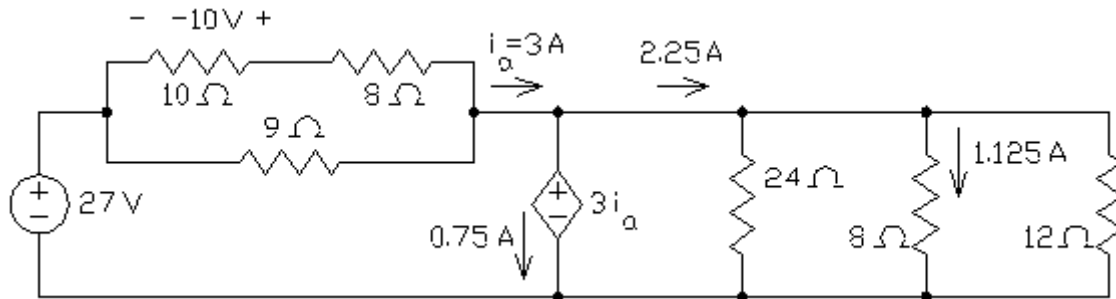

$$i_2 = \frac{\frac{1}{8}}{\frac{1}{24} + \frac{1}{8} + \frac{1}{12}} 2.25 = 1.125\text{ A} \quad \text{and} \quad v_1 = -(10) \left[\frac{9}{(10+8)+9} \right] = -10\text{ V}$$

P3.7-5

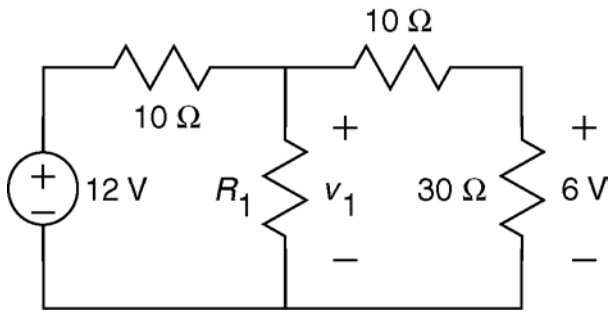

$$\frac{30}{10+30}v_1 = 6 \Rightarrow v_1 = 8 \text{ V}$$

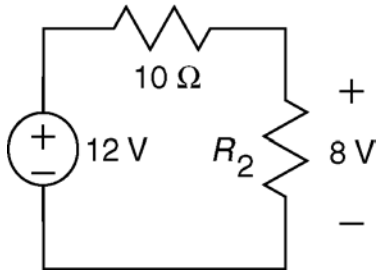

$$\frac{R_2}{R_2+10}12 = 8 \Rightarrow R_2 = 20 \Omega$$

$$20 = \frac{R_1(10+30)}{R_1+(10+30)} \Rightarrow R_1 = 40 \Omega$$

Alternate values that can be used to change the numbers in this problem:

meter reading, V	Right-most resistor, Ω	R_1, Ω
6	30	40
4	30	10
4	20	15
4.8	20	30

P3.7-6

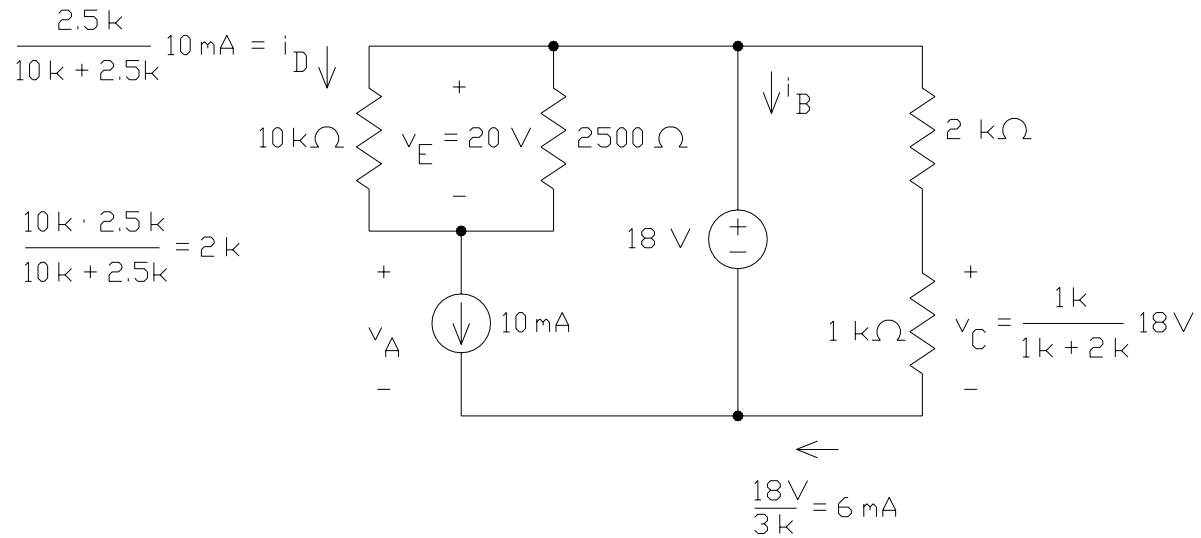

P3.7-7

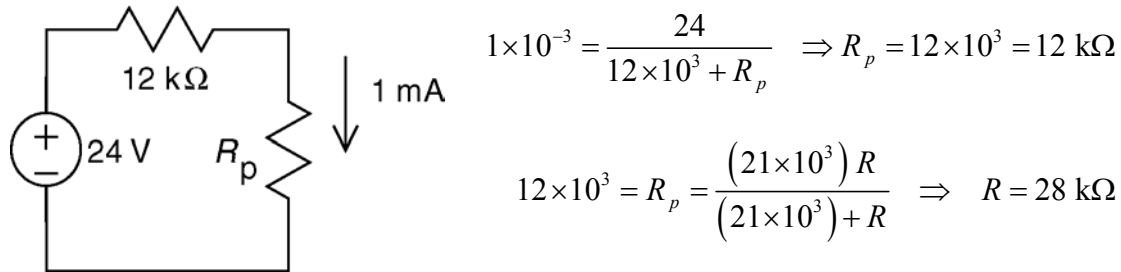

P3.7-8

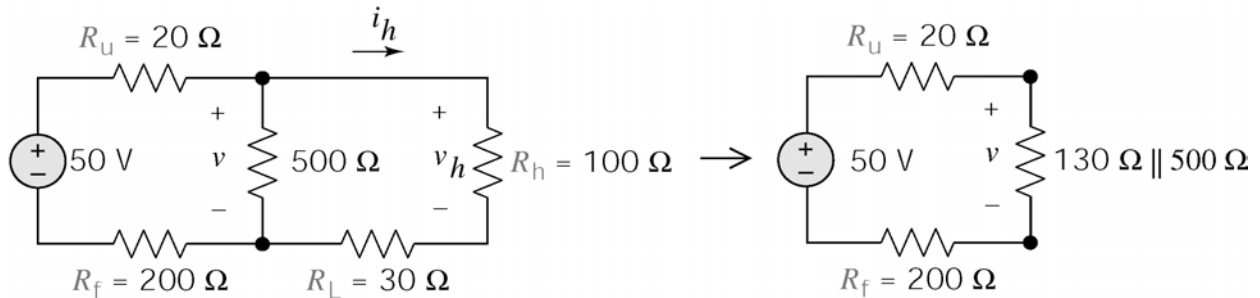

Voltage division $\Rightarrow v = 50 \left(\frac{130 \parallel 500}{130 \parallel 500 + 200 + 20} \right) = 15.963 \text{ V}$

$\therefore v_h = v \left(\frac{100}{100 + 30} \right) = (15.963) \left(\frac{10}{13} \right) = 12.279 \text{ V}$

$\therefore i_h = \frac{v_h}{100} = 122.79 \text{ A}$

P3.7-9

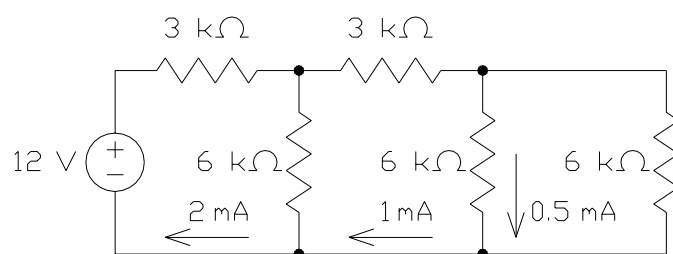
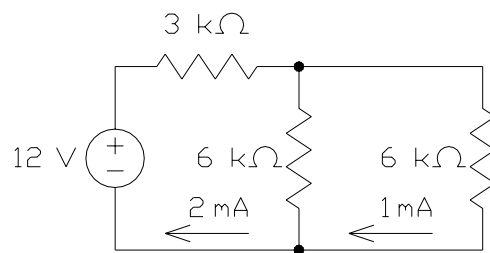
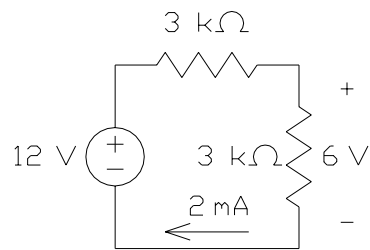
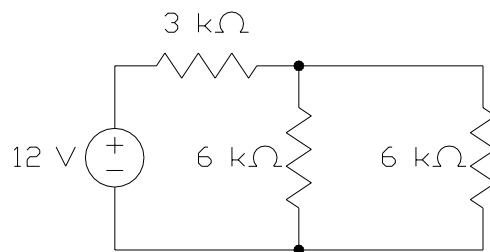
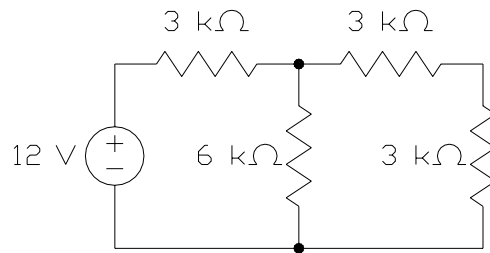
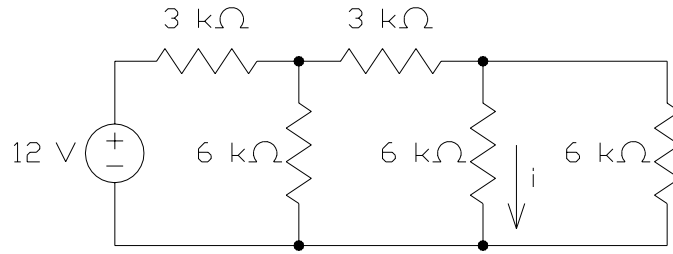

P3.7-10

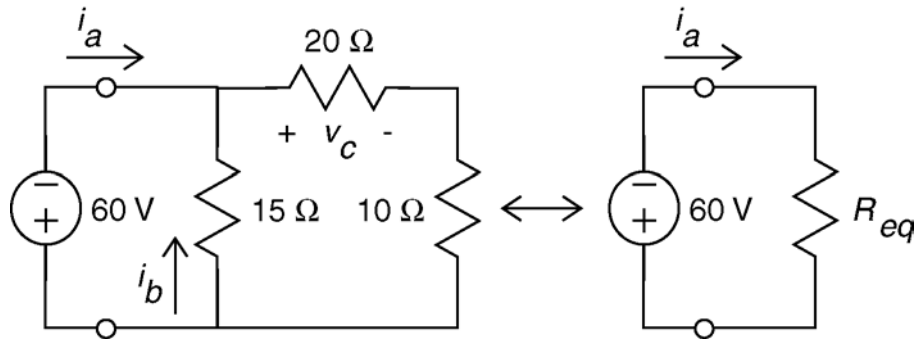

$$R_{eq} = \frac{15(20+10)}{15+(20+10)} = 10 \Omega$$

$$i_a = -\frac{60}{R_{eq}} = -6 \text{ A}, \quad i_b = \left(\frac{30}{30+15}\right)\left(\frac{60}{R_{eq}}\right) = 4 \text{ A}, \quad v_c = \left(\frac{20}{20+10}\right)(-60) = -40 \text{ V}$$

P3.7-11

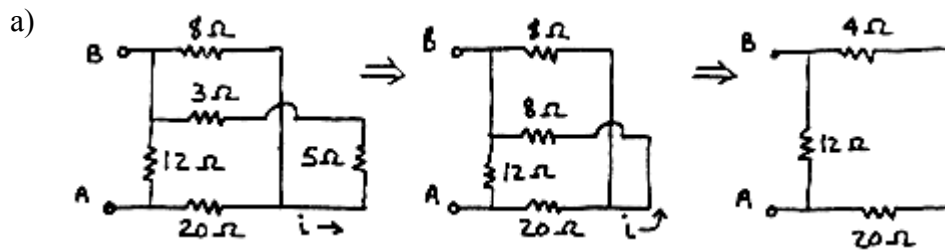

$$R_{eq} = 24 \parallel 12 = \frac{(24)(12)}{24 + 12} = 8 \Omega$$

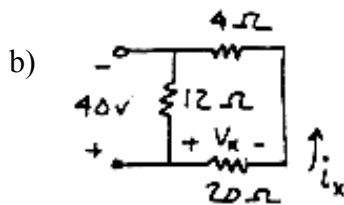

from voltage division:

$$v_x = 40 \left(\frac{20}{20+4} \right) = \frac{100}{3} \text{ V} \therefore i_x = \frac{\frac{100}{3}}{20} = \frac{5}{3} \text{ A}$$

from current division: $i = i_x \left(\frac{8}{8+8} \right) = \frac{5}{6} \text{ A}$

P3.7-12

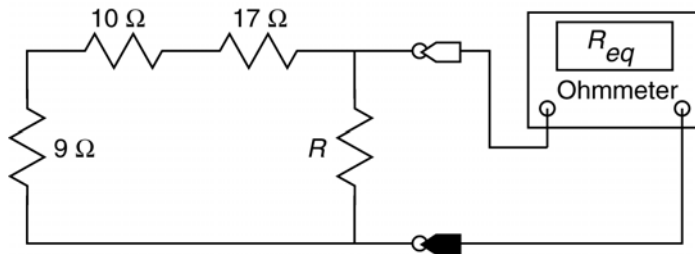

$$9 + 10 + 17 = 36 \Omega$$

$$\text{a.) } \frac{36(18)}{36+18} = 12 \Omega$$

$$\text{b.) } \frac{36R}{36+R} = 18 \Rightarrow 18R = (18)(36) \Rightarrow R = 36 \Omega$$

P3.7-13

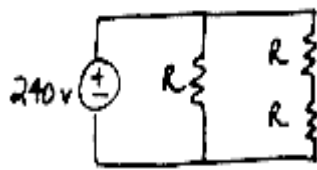

$$R_{eq} = \frac{2R(R)}{2R+R} = \frac{2}{3}R$$

$$P_{deliv. \text{ to ckt}} = \frac{v^2}{R_{eq}} = \frac{240^2}{\frac{2}{3}R} = 1920 \text{ W}$$

Thus $R=45 \Omega$

P3.7-14

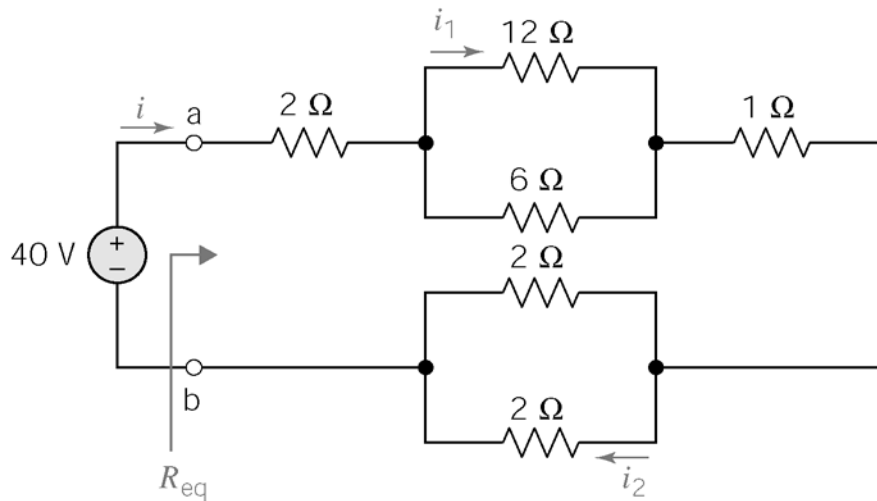

$$R_{eq} = 2 + 1 + (6 \parallel 12) + (2 \parallel 2) = 3 + 4 + 1 = \underline{8 \Omega}$$

$$\therefore i = \frac{40}{R_{eq}} = \frac{40}{8} = \underline{5 \text{ A}}$$

$$i_1 = i \left(\frac{6}{6+12} \right) = (5) \left(\frac{1}{3} \right) = \underline{\frac{5}{3} \text{ A}} \quad \text{from current division}$$

$$i_2 = i \left(\frac{2}{2+2} \right) = (5) \left(\frac{1}{2} \right) = \underline{\frac{5}{2} \text{ A}}$$

Verification Problems

VP3-1

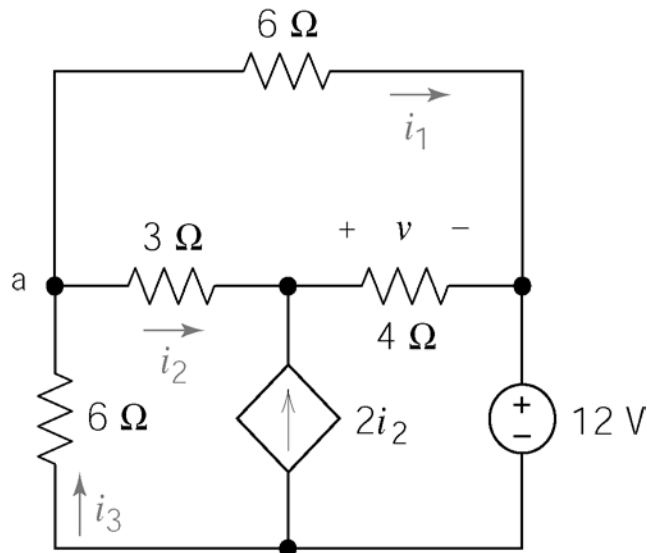

KCL at node a: $i_3 = i_1 + i_2$

$$-1.167 = -0.833 + (-0.333)$$

$$-1.167 = -1.166 \text{ OK}$$

KVL loop consisting of the vertical 6 Ω resistor, the 3 Ω and 4 Ω resistors, and the voltage source:

$$6i_3 + 3i_2 + v + 12 = 0$$

yields $v = -4.0 \text{ V}$ not $v = -2.0 \text{ V}$

VP3-2

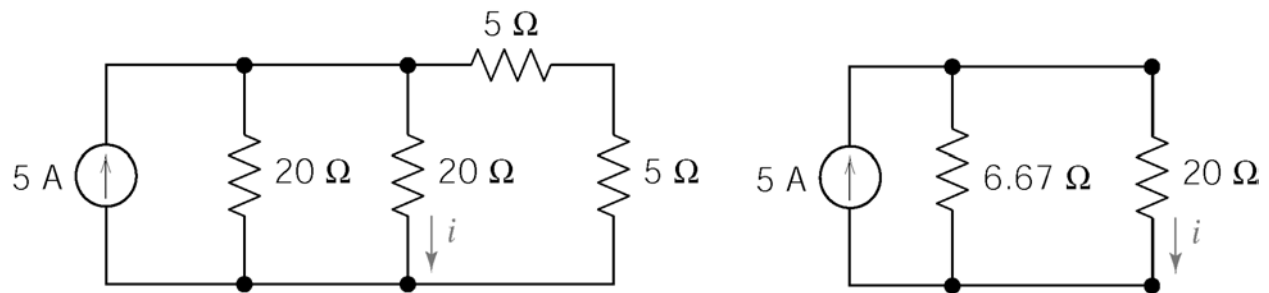

reduce circuit: $5+5=10$ in parallel with 20Ω gives 6.67Ω

by current division: $i = \left(\frac{6.67}{20+6.67} \right) 5 = \underline{1.25 \text{ A}}$

\therefore Reported value was correct.

VP3-3

$$v_o = \left(\frac{320}{320+650+230} \right) (24) = \underline{6.4 \text{ V}}$$

\therefore Reported value was incorrect.

VP3-4

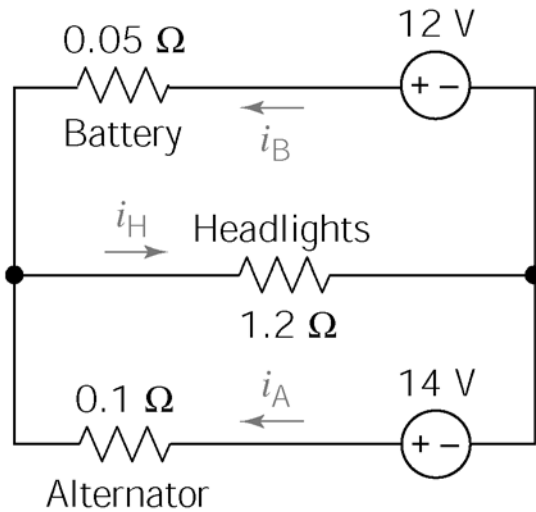

KVL bottom loop: $-14 + 0.1i_A + 1.2i_H = 0$

KVL right loop: $-12 + 0.05i_B + 1.2i_H = 0$

KCL at left node: $i_A + i_B = i_H$

This alone shows the reported results were incorrect.

Solving the three above equations yields:

$i_A = 16.8 \text{ A}$

$i_H = 10.3 \text{ A}$

$i_B = -6.49 \text{ A}$

∴ Reported values were incorrect.

VP3-5

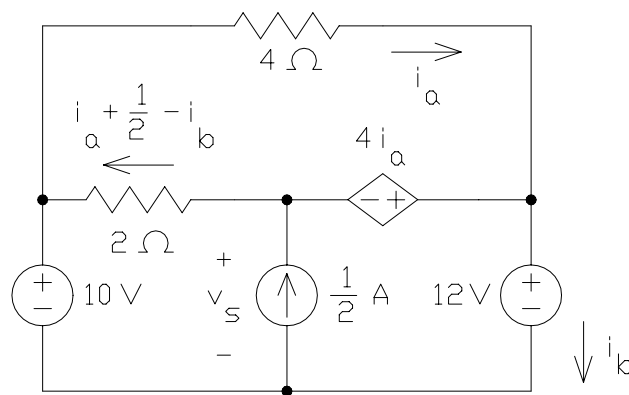

Top mesh: $0 = 4i_a + 4i_a + 2\left(i_a + \frac{1}{2} - i_b\right) = 10(-0.5) + 1 - 2(-2)$

Lower left mesh: $v_s = 10 + 2\left(i_a + 0.5 - i_b\right) = 10 + 2(2) = 14 \text{ V}$

Lower right mesh: $v_s + 4i_a = 12 \Rightarrow v_s = 12 - 4(-0.5) = 14 \text{ V}$

The KVL equations are satisfied so the analysis is correct.

VP3-6

Apply KCL at nodes b and c to get:

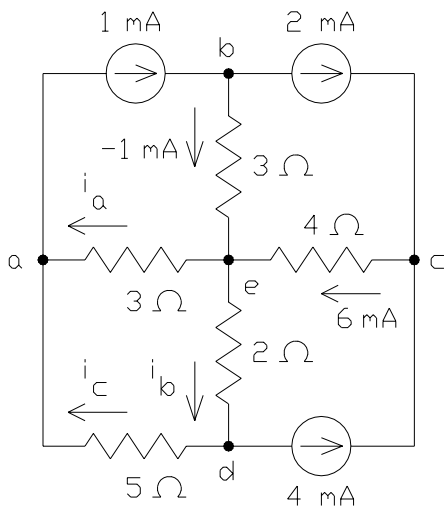

KCL equations:

$$\text{Node e: } -1 + 6 = 0.5 + 4.5$$

$$\text{Node a: } 0.5 + i_c = -1 \Rightarrow i_c = -1.5 \text{ mA}$$

$$\text{Node d: } i_c + 4 = 4.5 \Rightarrow i_c = 0.5 \text{ mA}$$

That's a contradiction. The given values of i_a and i_b are not correct.

Design Problems

DP3-1

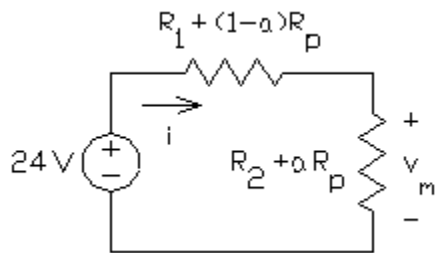

Using voltage division:

$$v_m = \frac{R_2 + aR_p}{R_1 + (1-a)R_p + R_2 + aR_p} 24 = \frac{R_2 + aR_p}{R_1 + R_2 + R_p} 24$$

$$v_m = 8 \text{ V when } a = 0 \Rightarrow$$

$$\frac{R_2}{R_1 + R_2 + R_p} = \frac{1}{3}$$

$$v_m = 12 \text{ V when } a = 1 \Rightarrow$$

$$\frac{R_2 + R_p}{R_1 + R_2 + R_p} = \frac{1}{2}$$

The specification on the power of the voltage source indicates

$$\frac{24^2}{R_1 + R_2 + R_p} \leq \frac{1}{2} \Rightarrow R_1 + R_2 + R_p \geq 1152 \Omega$$

Try $R_p = 2000 \Omega$. Substituting into the equations obtained above using voltage division gives $3R_2 = R_1 + R_2 + 2000$ and $2(R_2 + 2000) = R_1 + R_2 + 2000$. Solving these equations gives $R_1 = 6000 \Omega$ and $R_2 = 4000 \Omega$.

With these resistance values, the voltage source supplies 48 mW while R_1 , R_2 and R_p dissipate 24 mW, 16 mW and 8 mW respectively. Therefore the design is complete.

DP3-2

Try $R_1 = \infty$. That is, R_1 is an open circuit. From KVL, 8 V will appear across R_2 . Using voltage division, $\frac{200}{R_2 + 200} 12 = 4 \Rightarrow R_2 = 400 \Omega$. The power required to be dissipated by R_2

is $\frac{8^2}{400} = 0.16 \text{ W} < \frac{1}{8} \text{ W}$. To reduce the voltage across any one resistor, let's implement R_2 as the series combination of two 200Ω resistors. The power required to be dissipated by each of these resistors is $\frac{4^2}{200} = 0.08 \text{ W} < \frac{1}{8} \text{ W}$.

Now let's check the voltage:

$$11.88 \frac{190}{190 + 420} < v_0 < 12.12 \frac{210}{210 + 380}$$

$$3.700 < v_0 < 4.314$$

$$4 - 7.5\% < v_0 < 4 + 7.85\%$$

Hence, $v_0 = 4 \text{ V} \pm 8\%$ and the design is complete.

DP3-3

$$V_{ab} \cong 200 \text{ mV}$$

$$v = \frac{10}{10 + R} 120 V_{ab} = \frac{10}{10 + R} (120) (0.2)$$

$$\text{let } v = 16 = \frac{240}{10 + R} \Rightarrow \underline{R = 5 \Omega}$$

$$\therefore P = \frac{16^2}{10} = \underline{25.6 \text{ W}}$$

DP3-4

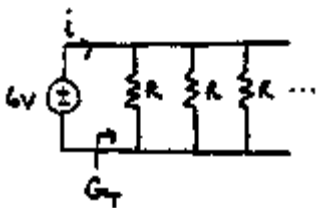

$$i = G_T v = \frac{N}{R} v \quad \text{where } G_T = \sum_{n=1}^N \frac{1}{R_n} = N \left(\frac{1}{R} \right)$$

$$\therefore N = \frac{iR}{v} = \frac{(9)(12)}{6} = \underline{18 \text{ bulbs}}$$

Chapter 4 – Methods of Analysis of Resistive Circuits

Exercises

Ex. 4.3-1

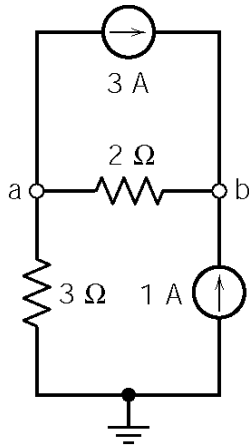

$$\text{KCL at a: } \frac{v_a}{3} + \frac{v_a - v_b}{2} + 3 = 0 \Rightarrow 5v_a - 3v_b = -18$$

$$\text{KCL at b: } \frac{v_b - v_a}{2} - 3 - 1 = 0 \Rightarrow v_b - v_a = 8$$

Solving these equations gives:

$$v_a = 3 \text{ V and } v_b = 11 \text{ V}$$

Ex. 4.3-2

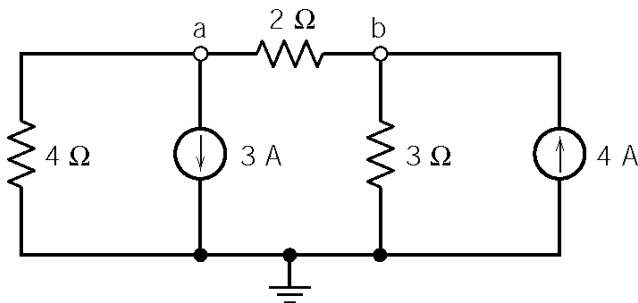

KCL at a:

$$\frac{v_a}{4} + \frac{v_a - v_b}{2} + 3 = 0 \Rightarrow 3v_a - 2v_b = -12$$

$$\text{KCL at b: } \frac{v_b}{3} - \frac{v_a - v_b}{2} - 4 = 0$$

$$\Rightarrow -3v_a + 5v_b = 24$$

Solving:

$$v_a = -4/3 \text{ V and } v_b = 4 \text{ V}$$

Ex. 4.4-1

Apply KCL to the supernode to get

$$2 + \frac{v_b + 10}{20} + \frac{v_b}{30} = 5$$

Solving:

$$v_b = 30 \text{ V and } v_a = v_b + 10 = 40 \text{ V}$$

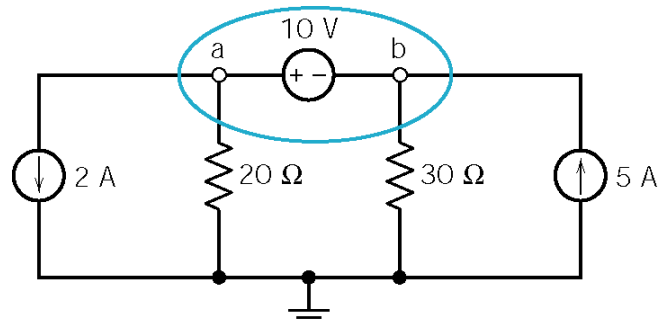

Ex. 4.4-2

$$\frac{(v_b + 8) - (-12)}{10} + \frac{v_b}{40} = 3 \Rightarrow v_b = 8 \text{ V and } v_a = 16 \text{ V}$$

Ex. 4.5-1

Apply KCL at node a to express i_a as a function of the node voltages. Substitute the result into $v_b = 4 i_a$ and solve for v_b .

$$\frac{6}{8} + \frac{v_b}{12} = i_a \Rightarrow v_b = 4 i_a = 4 \left(\frac{9 + v_b}{12} \right) \Rightarrow v_b = 4.5 \text{ V}$$

Ex. 4.5-2

The controlling voltage of the dependent source is a node voltage so it is already expressed as a function of the node voltages. Apply KCL at node a.

$$\frac{v_a - 6}{20} + \frac{v_a - 4 v_a}{15} = 0 \Rightarrow v_a = -2 \text{ V}$$

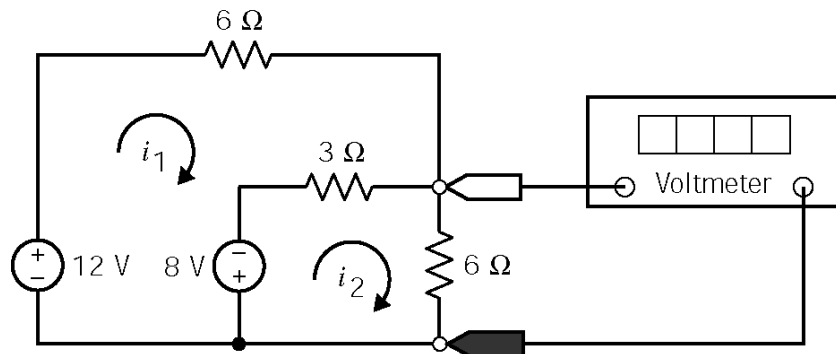
Ex. 4.6-1

Mesh equations:

$$-12 + 6i_1 + 3(i_1 - i_2) - 8 = 0 \Rightarrow 9i_1 - 3i_2 = 20$$

$$8 - 3(i_1 - i_2) + 6i_2 = 0 \Rightarrow -3i_1 + 9i_2 = -8$$

Solving these equations gives:

$$i_1 = \frac{13}{6} \text{ A and } i_2 = -\frac{1}{6} \text{ A}$$

The voltage measured by the meter is $6 i_2 = -1 \text{ V}$.

Ex. 4.7-1

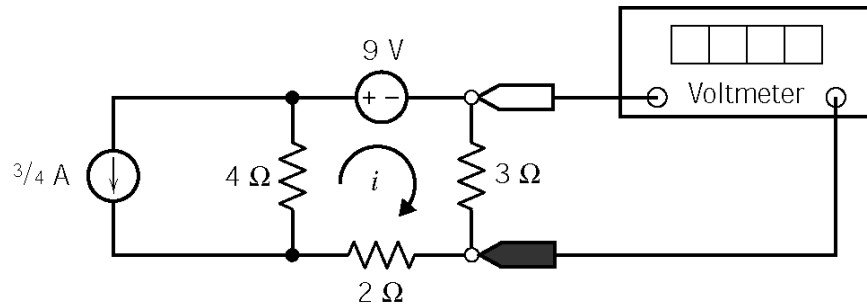

Mesh equation: $9 + 3i + 2i + 4\left(i + \frac{3}{4}\right) = 0 \Rightarrow (3 + 2 + 4)i = -9 - 3 \Rightarrow i = \frac{-12}{9} \text{ A}$

The voltmeter measures $3i = -4 \text{ V}$

Ex. 4.7-2

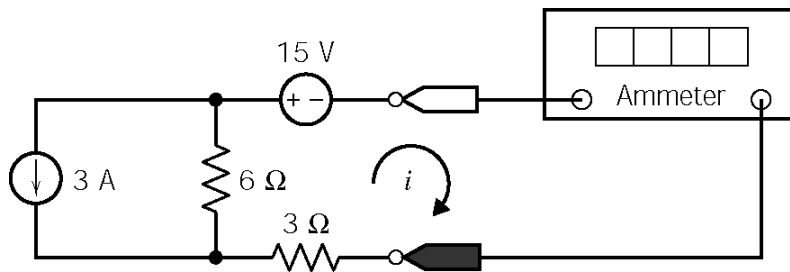

Mesh equation: $15 + 3i + 6(i + 3) = 0 \Rightarrow (3 + 6)i = -15 - 6(3) \Rightarrow i = \frac{-33}{9} = -3\frac{2}{3} \text{ A}$

Ex. 4.7-3

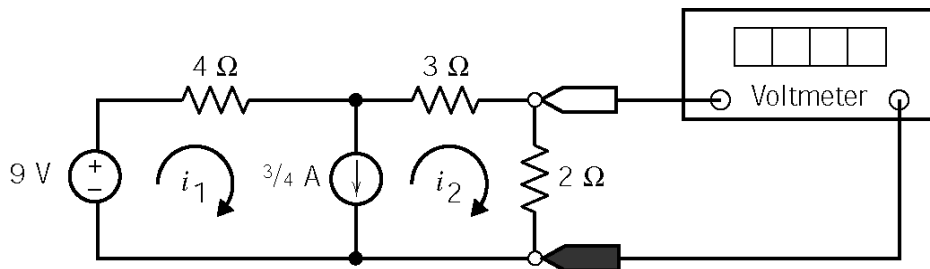

Express the current source current in terms of the mesh currents: $\frac{3}{4} = i_1 - i_2 \Rightarrow i_1 = \frac{3}{4} + i_2$.

Apply KVL to the supermesh: $-9 + 4i_1 + 3i_2 + 2i_2 = 0 \Rightarrow 4\left(\frac{3}{4} + i_2\right) + 5i_2 = 9 \Rightarrow 9i_2 = 6$

so $i_2 = \frac{2}{3} \text{ A}$ and the voltmeter reading is $2i_2 = \frac{4}{3} \text{ V}$

Ex. 4.7-4

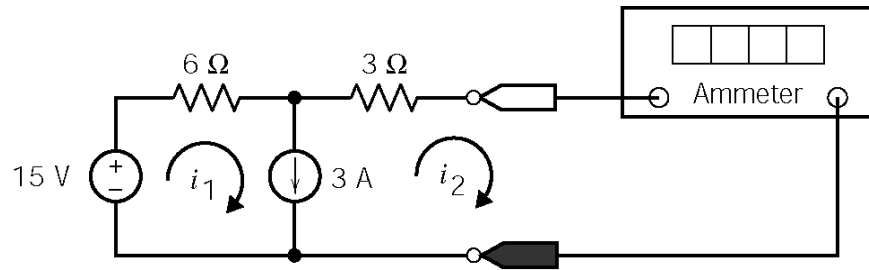

Express the current source current in terms of the mesh currents: $3 = i_1 - i_2 \Rightarrow i_1 = 3 + i_2$.

Apply KVL to the supermesh: $-15 + 6i_1 + 3i_2 = 0 \Rightarrow 6(3 + i_2) + 3i_2 = 15 \Rightarrow 9i_2 = -3$

Finally, $i_2 = -\frac{1}{3}$ A is the current measured by the ammeter.

Problems

Section 4-3 Node Voltage Analysis of Circuits with Current Sources

P4.3-1

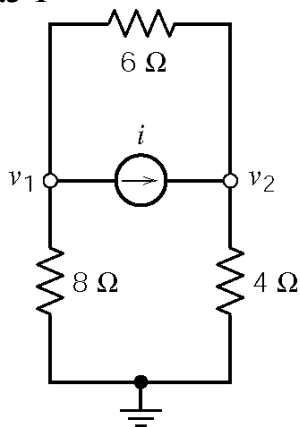

KCL at node 1:

$$0 = \frac{v_1}{8} + \frac{v_1 - v_2}{6} + i = \frac{-4}{8} + \frac{-4 - 2}{6} + i = -1.5 + i \Rightarrow i = 1.5 \text{ A}$$

(checked using LNAP 8/13/02)

P4.3-2

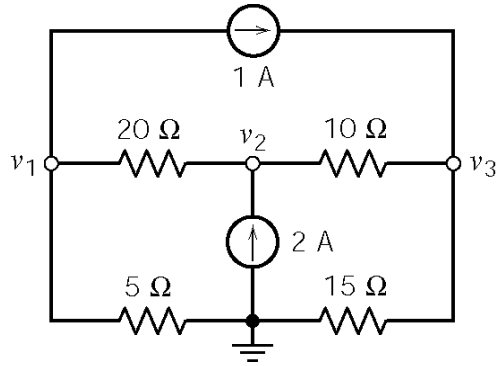

KCL at node 1:

$$\frac{v_1 - v_2}{20} + \frac{v_1}{5} + 1 = 0 \Rightarrow 5v_1 - v_2 = -20$$

KCL at node 2:

$$\frac{v_1 - v_2}{20} + 2 = \frac{v_2 - v_3}{10} \Rightarrow -v_1 + 3v_2 - 2v_3 = 40$$

KCL at node 3:

$$\frac{v_2 - v_3}{10} + 1 = \frac{v_3}{15} \Rightarrow -3v_2 + 5v_3 = 30$$

Solving gives $v_1 = 2$ V, $v_2 = 30$ V and $v_3 = 24$ V.

(checked using LNAP 8/13/02)

P4.3-3

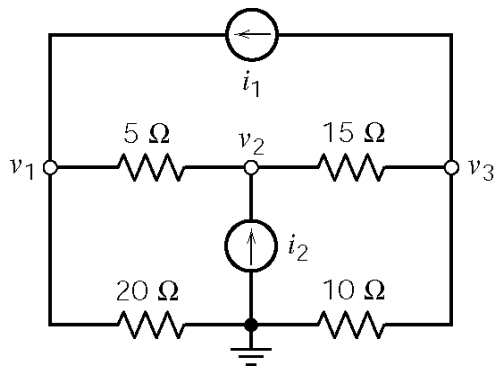

KCL at node 1:

$$\frac{v_1 - v_2}{5} + \frac{v_1}{20} = i_1 \Rightarrow i_1 = \frac{4 - 15}{5} + \frac{4}{20} = -2 \text{ A}$$

KCL at node 2:

$$\begin{aligned} \frac{v_1 - v_2}{5} + i_2 &= \frac{v_2 - v_3}{15} \\ \Rightarrow i_2 &= -\left(\frac{4 - 15}{5}\right) + \frac{15 - 18}{15} = 2 \text{ A} \end{aligned}$$

(checked using LNAP 8/13/02)

P4.3-4

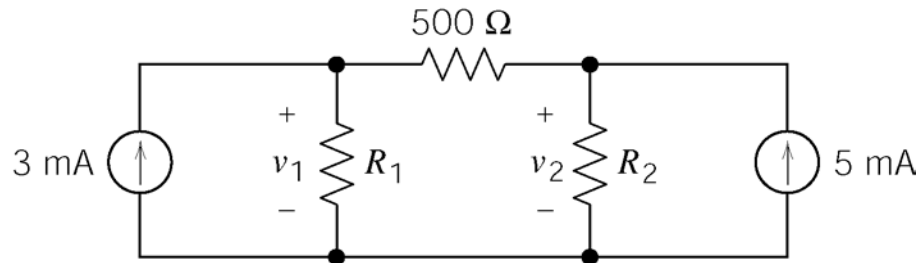

Node equations:

$$-.003 + \frac{v_1}{R_1} + \frac{v_1 - v_2}{500} = 0$$

$$-\frac{v_1 - v_2}{500} + \frac{v_2}{R_2} - .005 = 0$$

When $v_1 = 1 \text{ V}$, $v_2 = 2 \text{ V}$

$$-.003 + \frac{1}{R_1} + \frac{-1}{500} = 0 \Rightarrow R_1 = \frac{1}{.003 + \frac{1}{500}} = \underline{200 \Omega}$$

$$-\frac{-1}{500} + \frac{2}{R_2} - .005 = 0 \Rightarrow R_2 = \frac{2}{.005 - \frac{1}{500}} = \underline{667 \Omega}$$

(checked using LNAP 8/13/02)

P4.3-5

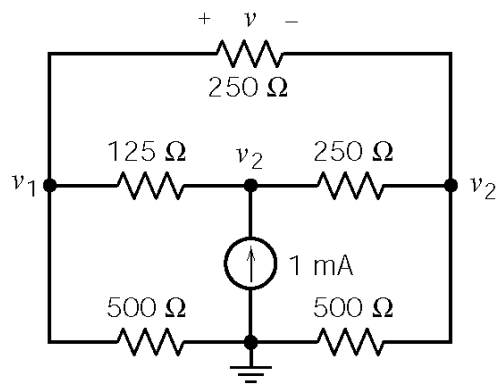

Node equations:

$$\frac{v_1}{500} + \frac{v_1 - v_2}{125} + \frac{v_1 - v_3}{250} = 0$$

$$-\frac{v_1 - v_2}{125} - .001 + \frac{v_2 - v_3}{250} = 0$$

$$-\frac{v_2 - v_3}{250} - \frac{v_1 - v_3}{250} + \frac{v_3}{500} = 0$$

Solving gives:

$$v_1 = 0.261 \text{ V}, \quad v_2 = 0.337 \text{ V}, \quad v_3 = 0.239 \text{ V}$$

Finally, $v = v_1 - v_3 = \underline{0.022 \text{ V}}$

(checked using LNAP 8/13/02)

Section 4-4 Node Voltage Analysis of Circuits with Current and Voltage Sources

P4.4-1

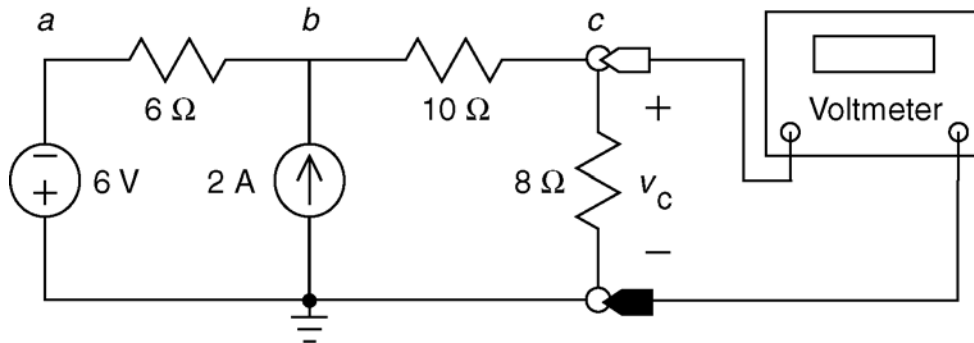

Express the branch voltage of the voltage source in terms of its node voltages:

$$0 - v_a = 6 \Rightarrow v_a = -6 \text{ V}$$

KCL at node b :

$$\frac{v_a - v_b}{6} + 2 = \frac{v_b - v_c}{10} \Rightarrow \frac{-6 - v_b}{6} + 2 = \frac{v_b - v_c}{10} \Rightarrow -1 - \frac{v_b}{6} + 2 = \frac{v_b - v_c}{10} \Rightarrow 30 = 8v_b - 3v_c$$

KCL at node c :

$$\frac{v_b - v_c}{10} = \frac{v_c}{8} \Rightarrow 4v_b - 4v_c = 5v_c \Rightarrow v_b = \frac{9}{4}v_c$$

Finally:

$$30 = 8\left(\frac{9}{4}v_c\right) - 3v_c \Rightarrow v_c = 2 \text{ V}$$

(checked using LNAP 8/13/02)

P4.4-2

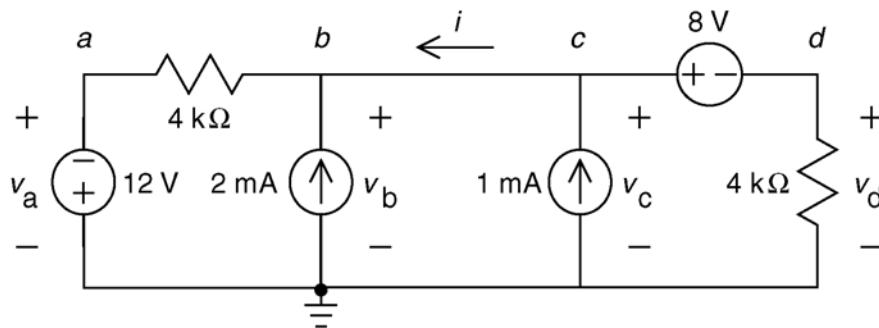

Express the branch voltage of each voltage source in terms of its node voltages to get:

$$v_a = -12 \text{ V}, v_b = v_c = v_d + 8$$

KCL at node b :

$$\frac{v_b - v_a}{4000} = 0.002 + i \Rightarrow \frac{v_b - (-12)}{4000} = 0.002 + i \Rightarrow v_b + 12 = 8 + 4000 i$$

KCL at the supernode corresponding to the 8 V source:

$$0.001 = \frac{v_d}{4000} + i \Rightarrow 4 = v_d + 4000 i$$

so $v_b + 4 = 4 - v_d \Rightarrow (v_d + 8) + 4 = 4 - v_d \Rightarrow v_d = -4 \text{ V}$

Consequently $v_b = v_c = v_d + 8 = 4 \text{ V}$ and $i = \frac{4 - v_d}{4000} = 2 \text{ mA}$

(checked using LNAP 8/13/02)

P4.4-3

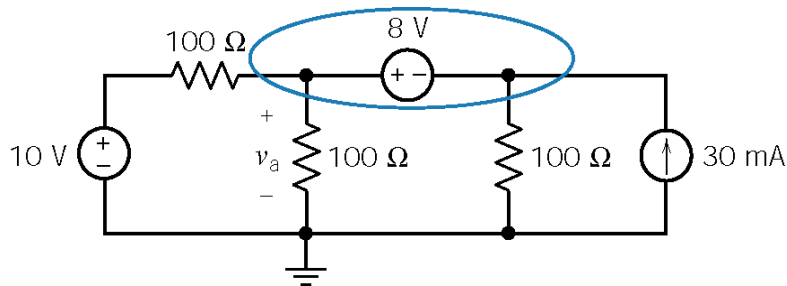

Apply KCL to the supernode:

$$\frac{v_a - 10}{100} + \frac{v_a}{100} + \frac{v_a - 8}{100} - .03 = 0 \Rightarrow \underline{v_a = 7 \text{ V}}$$

(checked using LNAP 8/13/02)

P4.4-4

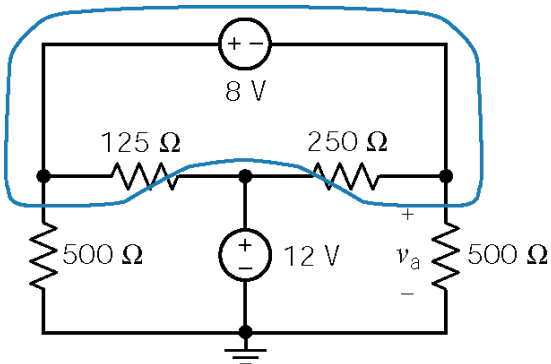

Apply KCL to the supernode:

$$\frac{v_a + 8}{500} + \frac{(v_a + 8) - 12}{125} + \frac{v_a - 12}{250} + \frac{v_a}{500} = 0$$

Solving yields

$$v_a = 4 \text{ V}$$

(checked using LNAP 8/13/02)

P4.4-5

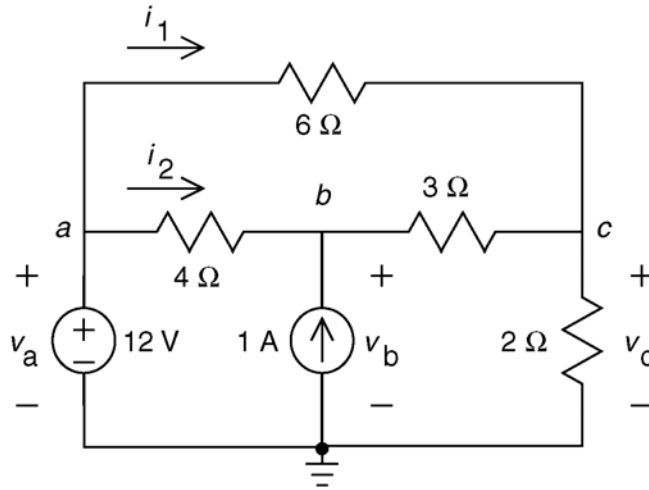

The power supplied by the voltage source is

$$v_a (i_1 + i_2) = v_a \left(\frac{v_a - v_b}{4} + \frac{v_a - v_c}{6} \right) = 12 \left(\frac{12 - 9.882}{4} + \frac{12 - 5.294}{6} \right)$$

$$= 12(0.5295 + 1.118) = 12(1.648) = 19.76 \text{ W}$$

(checked using LNAP 8/13/02)

P4.4-6

Label the voltage measured by the meter. Notice that this is a node voltage.

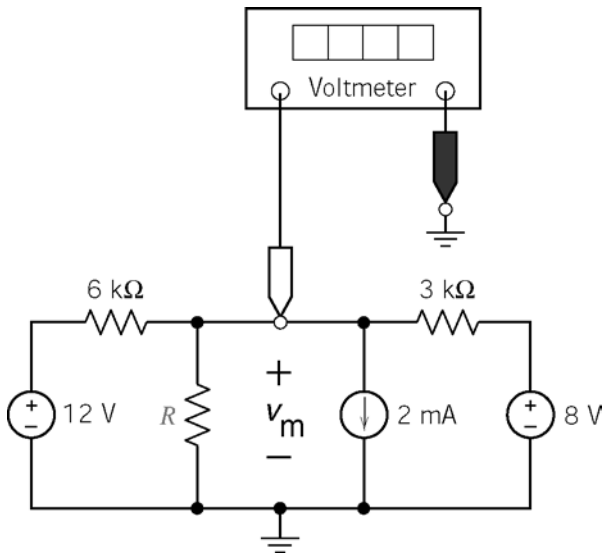

Write a node equation at the node at which the node voltage is measured.

$$-\left(\frac{12 - v_m}{6000} \right) + \frac{v_m}{R} + 0.002 + \frac{v_m - 8}{3000} = 0$$

That is

$$\left(3 + \frac{6000}{R} \right) v_m = 16 \Rightarrow R = \frac{6000}{\frac{16}{v_m} - 3}$$

- (a) The voltage measured by the meter will be 4 volts when $R = 6 \text{ k}\Omega$.
- (b) The voltage measured by the meter will be 2 volts when $R = 1.2 \text{ k}\Omega$.

Section 4-5 Node Voltage Analysis with Dependent Sources

P4.5-1

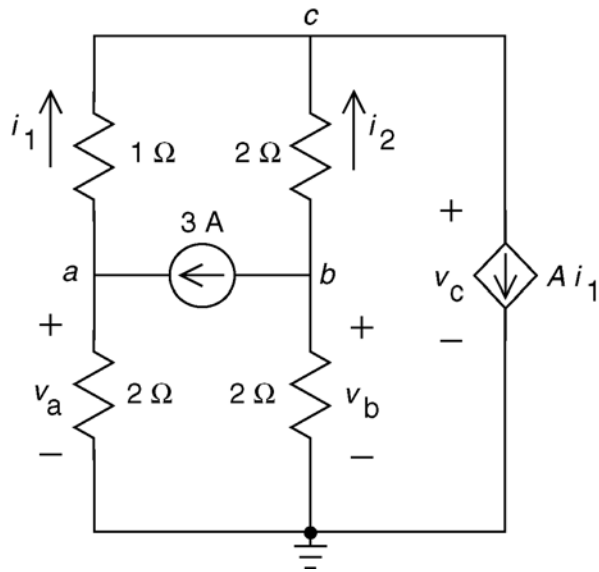

Express the resistor currents in terms of the node voltages:

$$i_1 = \frac{v_a - v_c}{1} = 8.667 - 10 = -1.333 \text{ A and}$$

$$i_2 = \frac{v_b - v_c}{2} = \frac{2 - 10}{2} = -4 \text{ A}$$

Apply KCL at node c:

$$i_1 + i_2 = A i_1 \Rightarrow -1.333 + (-4) = A(-1.333)$$

$$\Rightarrow A = \frac{-5.333}{-1.333} = 4$$

(checked using LNAP 8/13/02)

P4.5-2

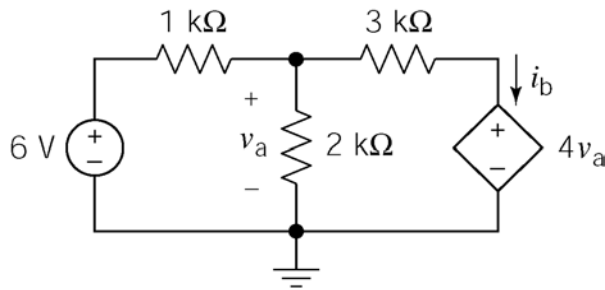

Write and solve a node equation:

$$\frac{v_a - 6}{1000} + \frac{v_a}{2000} + \frac{v_a - 4v_a}{3000} = 0 \Rightarrow v_a = 12 \text{ V}$$

$$i_b = \frac{v_a - 4v_a}{3000} = \underline{-12 \text{ mA}}$$

(checked using LNAP 8/13/02)

P4.5-3

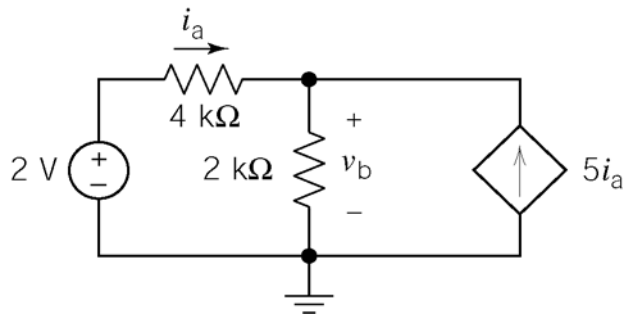

First express the controlling current in terms of the node voltages:

$$i_a = \frac{2 - v_b}{4000}$$

Write and solve a node equation:

$$-\frac{2 - v_b}{4000} + \frac{v_b}{2000} - 5\left(\frac{2 - v_b}{4000}\right) = 0 \Rightarrow \underline{v_b = 1.5 \text{ V}}$$

(checked using LNAP 8/14/02)

P4.5-4

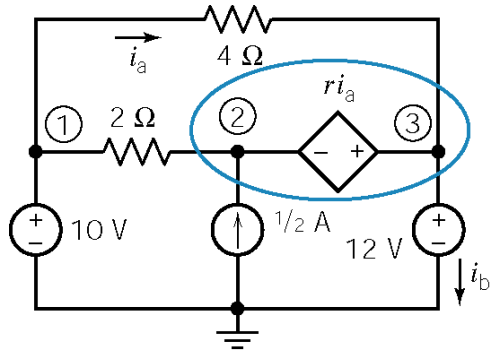

Apply KCL to the supernode of the CCVS to get

$$\frac{12-10}{4} + \frac{14-10}{2} - \frac{1}{2} + i_b = 0 \Rightarrow i_b = -2 \text{ A}$$

Next

$$\left. \begin{aligned} i_a &= \frac{10-12}{4} = -\frac{1}{2} \\ r i_a &= 12-14 \end{aligned} \right\} \Rightarrow r = \frac{-2}{-\frac{1}{2}} = 4 \frac{\text{V}}{\text{A}}$$

(checked using LNAP 8/14/02)

P4.5-5

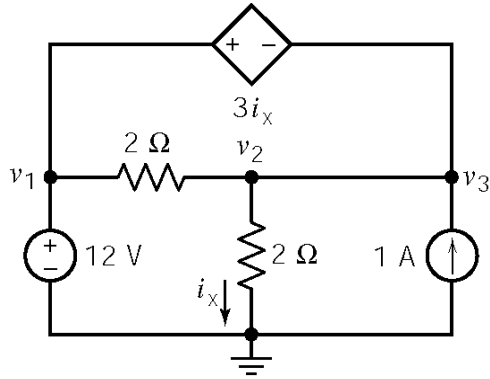

First, express the controlling current of the CCVS in terms of the node voltages: $i_x = \frac{v_2}{2}$

Next, express the controlled voltage in terms of the node voltages:

$$12 - v_2 = 3i_x = 3 \frac{v_2}{2} \Rightarrow v_2 = \frac{24}{5} \text{ V}$$

so $i_x = 12/5 \text{ A} = 2.4 \text{ A}$.

(checked using ELab 9/5/02)

Section 4-6 Mesh Current Analysis with Independent Voltage Sources

P 4.6-1

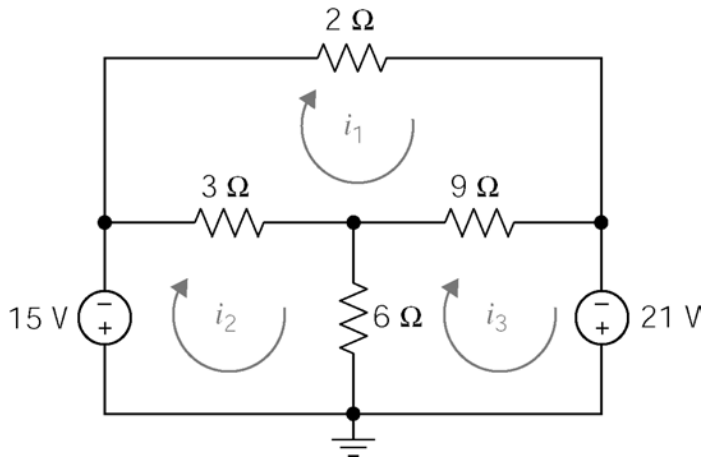

$$2i_1 + 9(i_1 - i_3) + 3(i_1 - i_2) = 0$$

$$15 - 3(i_1 - i_2) + 6(i_2 - i_3) = 0$$

$$-6(i_2 - i_3) - 9(i_1 - i_3) - 21 = 0$$

or

$$14i_1 - 3i_2 - 9i_3 = 0$$

$$-3i_1 + 9i_2 - 6i_3 = -15$$

$$-9i_1 - 6i_2 + 15i_3 = 21$$

so

$$i_1 = 3 \text{ A}, \quad i_2 = 2 \text{ A} \text{ and } i_3 = 4 \text{ A}.$$

(checked using LNAP 8/14/02)

P 4.6-2

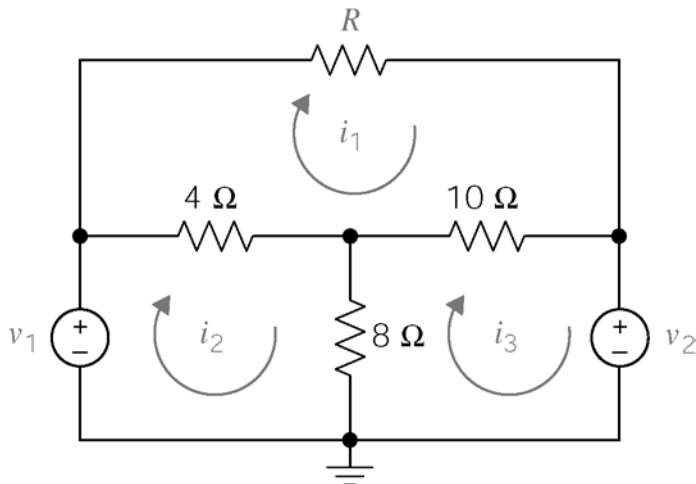

Top mesh:

$$4(2 - 3) + R(2) + 10(2 - 4) = 0$$

so $R = 12 \Omega$.

Bottom, right mesh:

$$8(4 - 3) + 10(4 - 2) + v_2 = 0$$

so $v_2 = -28 \text{ V}$.

Bottom left mesh

$$-v_1 + 4(3 - 2) + 8(3 - 4) = 0$$

so $v_1 = -4 \text{ V}$.

(checked using LNAP 8/14/02)

P 4.6-3

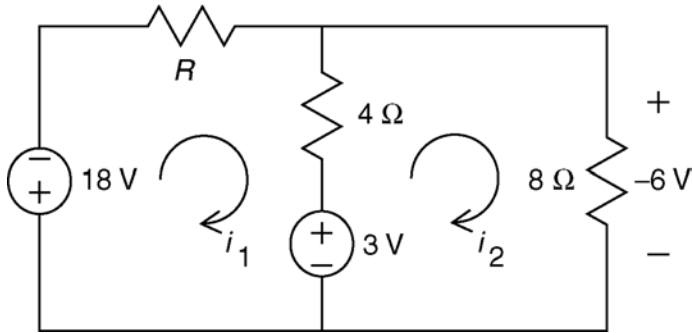

Ohm's Law: $i_2 = \frac{-6}{8} = -0.75 \text{ A}$

KVL for loop 1:
 $R i_1 + 4(i_1 - i_2) + 3 + 18 = 0$

KVL for loop 2:
 $+(-6) - 3 - 4(i_1 - i_2) = 0$

$\Rightarrow -9 - 4(i_1 - (-0.75)) = 0$

$\Rightarrow i_1 = -3 \text{ A}$

$R(-3) + 4(-3 - (-0.75)) + 21 = 0 \Rightarrow R = 4 \Omega$

(checked using LNAP 8/14/02)

P4.6-4

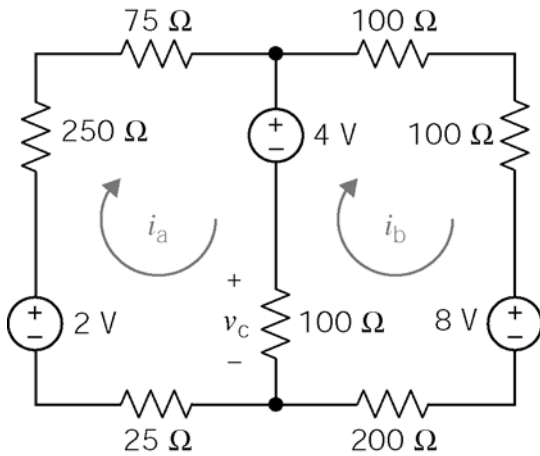

KVL loop 1:

$25 i_a - 2 + 250 i_a + 75 i_a + 4 + 100 (i_a - i_b) = 0$
 $450 i_a - 100 i_b = -2$

KVL loop 2:

$-100(i_a - i_b) - 4 + 100 i_b + 100 i_b + 8 + 200 i_b = 0$
 $-100 i_a + 500 i_b = -4$
 $\Rightarrow \underline{i_a = -6.5 \text{ mA}}, \underline{i_b = -9.3 \text{ mA}}$

(checked using LNAP 8/14/02)

P4.6-5

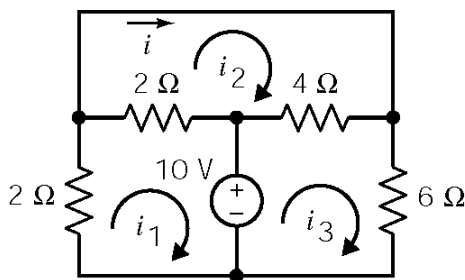

Mesh Equations:

mesh 1 : $2i_1 + 2(i_1 - i_2) + 10 = 0$

mesh 2 : $2(i_2 - i_1) + 4(i_2 - i_3) = 0$

mesh 3 : $-10 + 4(i_3 - i_2) + 6i_3 = 0$

Solving:

$i = i_2 \Rightarrow i = -\frac{5}{17} = -0.294 \text{ A}$

(checked using LNAP 8/14/02)

Section 4-7 Mesh Current Analysis with Voltage and Current Sources

P4.7-1

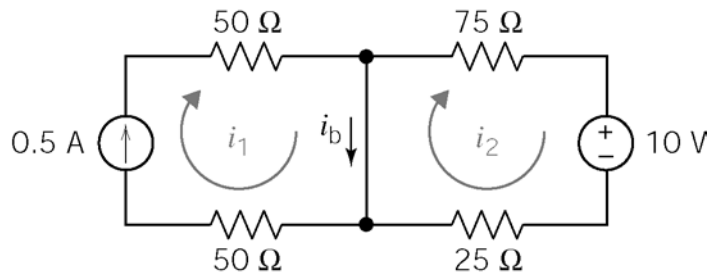

$$\text{mesh 1: } i_1 = \frac{1}{2} \text{ A}$$

$$\text{mesh 2: } 75 i_2 + 10 + 25 i_2 = 0$$

$$\Rightarrow i_2 = -0.1 \text{ A}$$

$$i_b = i_1 - i_2 = \underline{0.6 \text{ A}}$$

(checked using LNAP 8/14/02)

P4.7-2

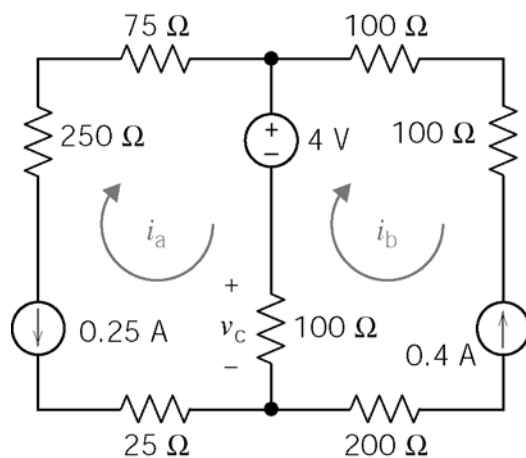

$$\text{mesh a: } i_a = -0.25 \text{ A}$$

$$\text{mesh b: } i_b = -0.4 \text{ A}$$

$$v_c = 100(i_a - i_b) = 100(0.15) = \underline{15 \text{ V}}$$

(checked using LNAP 8/14/02)

P4.7-3

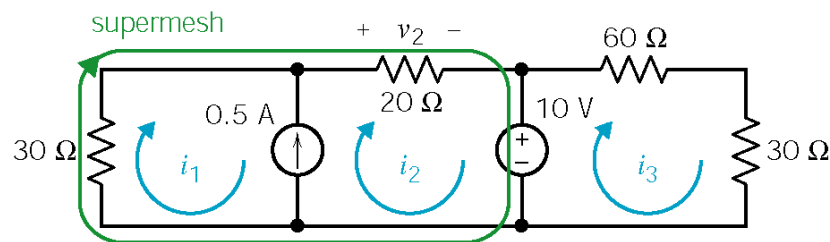

Express the current source current as a function of the mesh currents:

$$i_1 - i_2 = -0.5 \Rightarrow i_1 = i_2 - 0.5$$

Apply KVL to the supermesh:

$$30 i_1 + 20 i_2 + 10 = 0 \Rightarrow 30(i_2 - 0.5) + 20 i_2 = -10$$

$$50 i_2 - 15 = -10 \Rightarrow i_2 = \frac{5}{50} = .1 \text{ A}$$

$$i_1 = -0.4 \text{ A} \quad \text{and} \quad v_2 = 20 i_2 = \underline{2 \text{ V}}$$

(checked using LNAP 8/14/02)

P4.7-4

Express the current source current in terms of the mesh currents:

$$i_b = i_a - 0.02$$

Apply KVL to the supermesh:

$$250 i_a + 100 (i_a - 0.02) + 9 = 0$$

$$\therefore i_a = -0.02 \text{ A} = -20 \text{ mA}$$

$$v_c = 100(i_a - 0.02) = \underline{-4 \text{ V}}$$

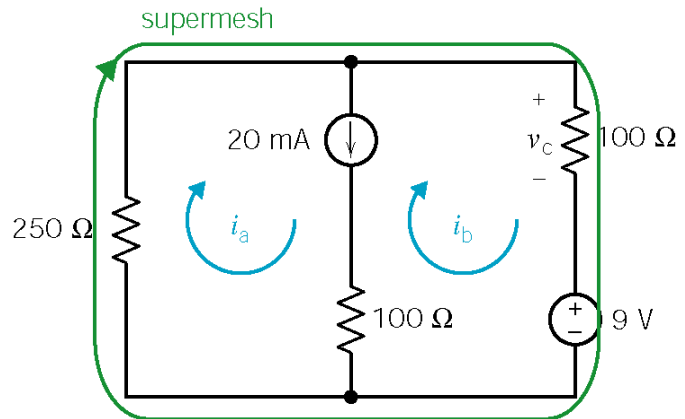

(checked using LNAP 8/14/02)

P4.7-5

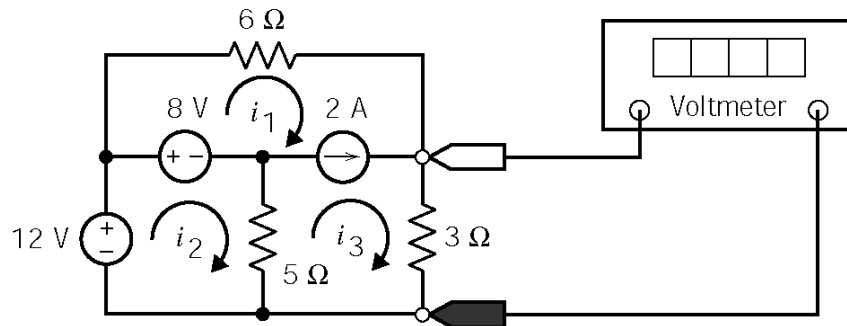

Express the current source current in terms of the mesh currents:

$$i_3 - i_1 = 2 \Rightarrow i_1 = i_3 - 2$$

Supermesh: $6 i_1 + 3 i_3 - 5 (i_2 - i_3) - 8 = 0 \Rightarrow 6 i_1 - 5 i_2 + 8 i_3 = 8$

Lower, left mesh: $-12 + 8 + 5 (i_2 - i_3) = 0 \Rightarrow 5 i_2 = 4 + 5 i_3$

Eliminating i_1 and i_2 from the supermesh equation:

$$6 (i_3 - 2) - (4 + 5 i_3) + 8 i_3 = 8 \Rightarrow 9 i_3 = 24$$

The voltage measured by the meter is: $3 i_3 = 3 \left(\frac{24}{9} \right) = 8 \text{ V}$

(checked using LNAP 8/14/02)

P4.7-6

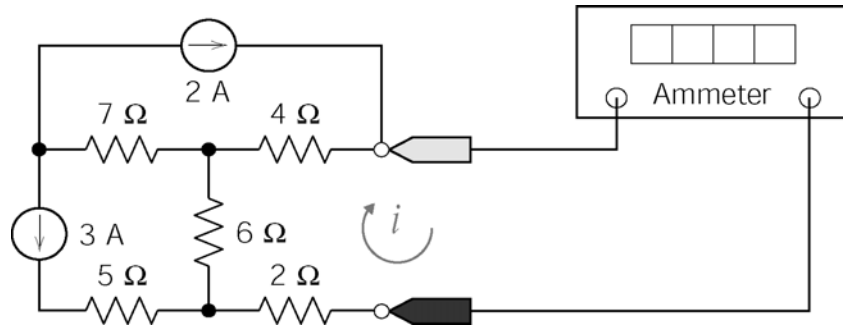

Mesh equation for right mesh:

$$4(i-2)+2i+6(i+3)=0 \Rightarrow 12i-8+18=0 \Rightarrow i=-\frac{10}{12} \text{ A} = -\frac{5}{6} \text{ A}$$

(checked using LNAP 8/14/02)

P 4.7-7

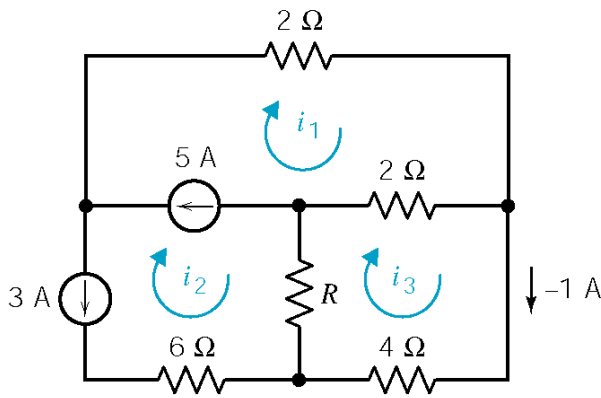

$$i_2 = -3 \text{ A}$$

$$i_1 - i_2 = 5 \Rightarrow i_1 - (-3) = 5$$

$$\Rightarrow i_1 = 2 \text{ A}$$

$$2(i_3 - i_1) + 4i_3 + R(i_3 - i_2) = 0$$

$$\Rightarrow 2(-1-2) + 4(-1) + R(-1-(-3)) = 0$$

$$\Rightarrow R = 5 \text{ } \Omega$$

(checked using LNAP 8/14/02)

P 4.7-8

Express the controlling voltage of the dependent source as a function of the mesh current

$$v_2 = 50 i_1$$

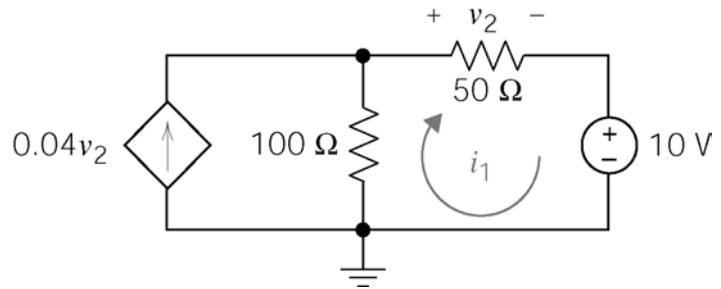

Apply KVL to the right mesh:

$$-100 (0.04(50i_1) - i_1) + 50i_1 + 10 = 0 \Rightarrow i_1 = 0.2 \text{ A}$$

$$v_2 = 50 i_1 = 10 \text{ V}$$

(checked using LNAP 8/14/02)

P 4.7-9

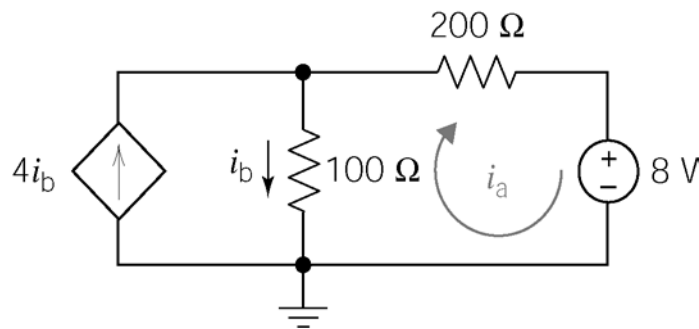

$$i_b = 4i_b - i_a \Rightarrow i_b = \frac{1}{3} i_a$$

$$-100 \left(\frac{1}{3} i_a \right) + 200i_a + 8 = 0$$

$$\Rightarrow \underline{i_a = -0.048 \text{ A}}$$

(checked using LNAP 8/14/02)

P4.7-10

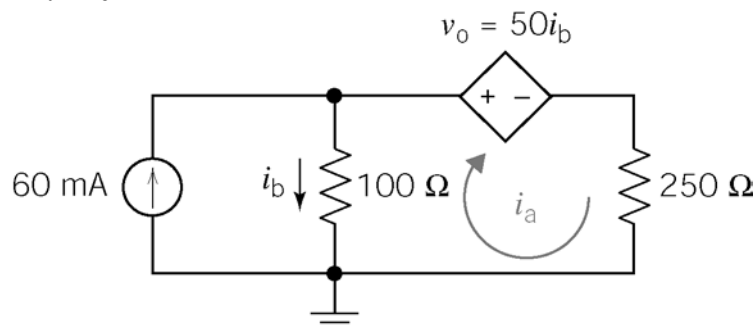

Express the controlling current of the dependent source as a function of the mesh current:

$$i_b = .06 - i_a$$

Apply KVL to the right mesh:

$$-100 (0.06 - i_a) + 50 (0.06 - i_a) + 250 i_a = 0 \Rightarrow i_a = 10 \text{ mA}$$

Finally:

$$v_o = 50 i_b = 50(0.06 - 0.01) = 2.5 \text{ V}$$

(checked using LNAP 8/14/02)

P4.7-11

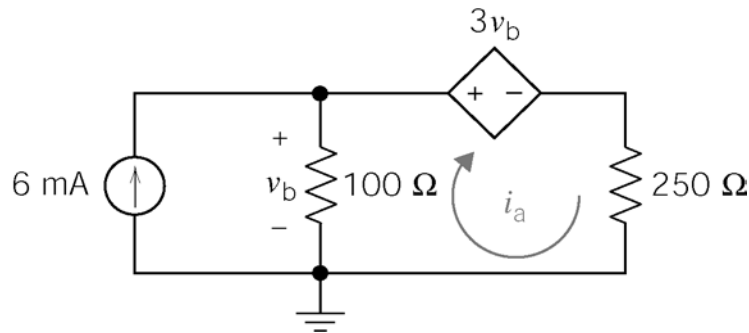

Express the controlling voltage of the dependent source as a function of the mesh current:

$$v_b = 100 (.006 - i_a)$$

Apply KVL to the right mesh:

$$-100 (.006 - i_a) + 3[100(.006 - i_a)] + 250 i_a = 0 \Rightarrow \underline{i_a = -24 \text{ mA}}$$

(checked using LNAP 8/14/02)

P4.7-12

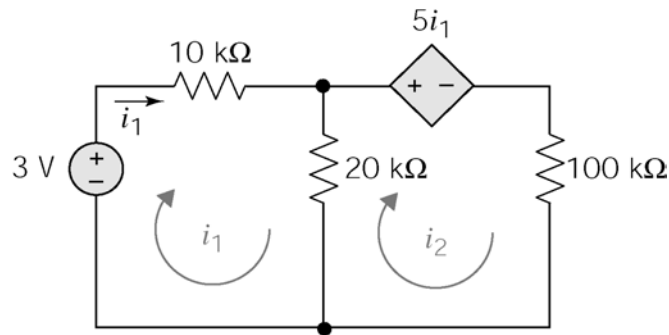

apply KVL to left mesh : $-3 + 10 \times 10^3 i_1 + 20 \times 10^3 (i_1 - i_2) = 0 \Rightarrow \underline{30 \times 10^3 i_1 - 20 \times 10^3 i_2 = 3}$ (1)

apply KVL to right mesh : $5 \times 10^3 i_1 + 100 \times 10^3 i_2 + 20 \times 10^3 (i_2 - i_1) = 0 \Rightarrow \underline{i_1 = 8i_2}$ (2)

Solving (1) & (2) simultaneously $\Rightarrow i_1 = \frac{6}{55} \text{ mA}, i_2 = \frac{3}{220} \text{ mA}$

$$\begin{aligned} \text{Power delivered to cathode} &= (5i_1)(i_2) + 100(i_2)^2 \\ &= 5\left(\frac{6}{55}\right)\left(\frac{3}{220}\right) + 100\left(\frac{3}{220}\right)^2 = 0.026 \text{ mW} \end{aligned}$$

$$\begin{aligned} \therefore \text{Energy in 24 hr.} &= Pt = \left(2.6 \times 10^{-5} \text{ W}\right)(24 \text{ hr})\left(3600 \text{ s/hr}\right) \\ &= \underline{2.25 \text{ J}} \end{aligned}$$

P4.7-13

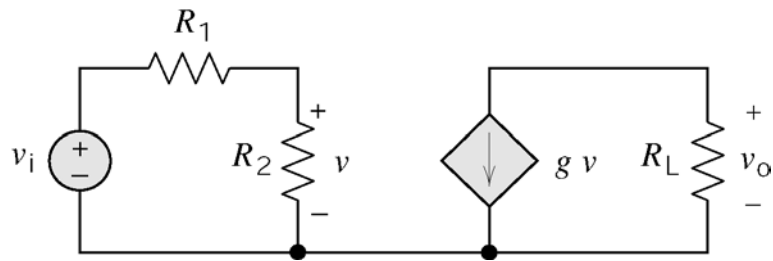

(a) $v_o = -g R_L v$ and $v = \frac{R_2}{R_1 + R_2} v_i \Rightarrow \frac{v_o}{v_i} = -g \frac{R_L R_2}{R_1 + R_2}$

(b) $\therefore \frac{v_o}{v_i} = -g \frac{(5 \times 10^3)(10^3)}{1.1 \times 10^3} = -170 \Rightarrow \underline{g = 0.0374 \text{ S}}$

PSpice Problems

SP 4-1

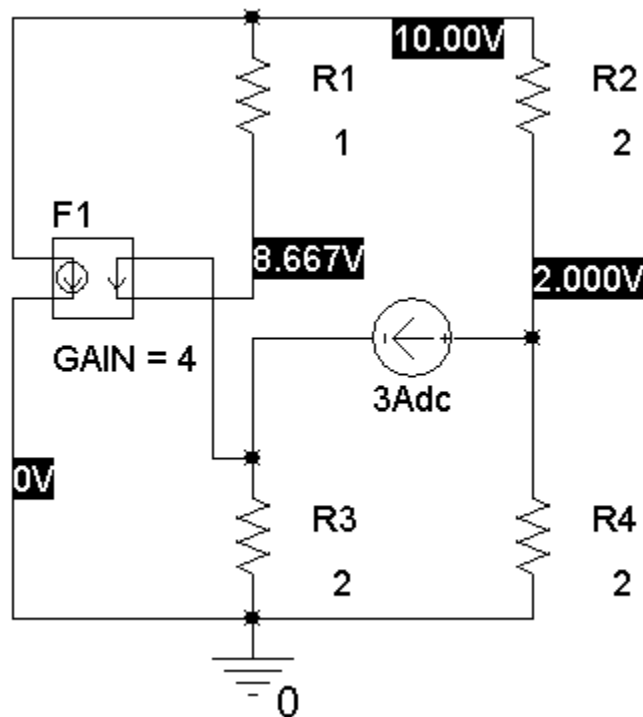

SP 4-2

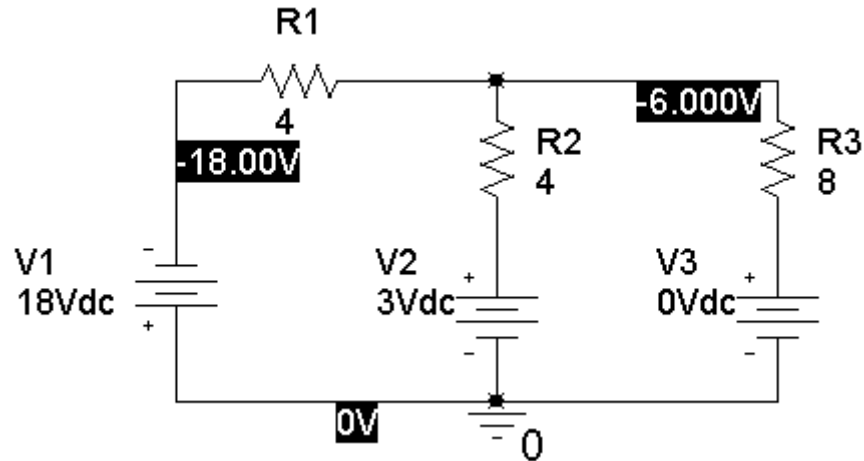

From the PSpice output file:

VOLTAGE SOURCE CURRENTS	
NAME	CURRENT
V_V1	-3.000E+00
V_V2	-2.250E+00
V_V3	-7.500E-01

The voltage source labeled V3 is a short circuit used to measure the mesh current. The mesh currents are $i_1 = -3$ A (the current in the voltage source labeled V1) and $i_2 = -0.75$ A (the current in the voltage source labeled V3).

SP 4-3

The PSpice schematic after running the simulation:

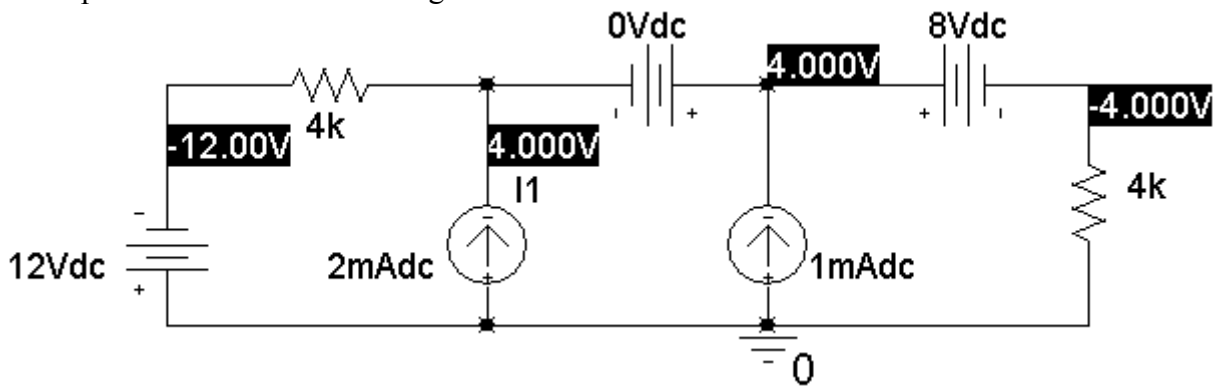

The PSpice output file:

```

**** INCLUDING sp4_2-SCHEMATIC1.net ****
* source SP4_2
V_V4      0 N01588 12Vdc
    
```

```

R_R4      N01588 N01565 4k
V_V5      N01542 N01565 0Vdc
R_R5      0 N01516 4k
V_V6      N01542 N01516 8Vdc
I_I1      0 N01565 DC 2mAdc
I_I2      0 N01542 DC 1mAdc

```

VOLTAGE SOURCE CURRENTS

NAME	CURRENT
V_V4	-4.000E-03
V_V5	2.000E-03
V_V6	-1.000E-03

From the PSpice schematic: $v_a = -12$ V, $v_b = v_c = 4$ V, $v_d = -4$ V. From the output file: $i = 2$ mA.

SP 4-4

The PSpice schematic after running the simulation:

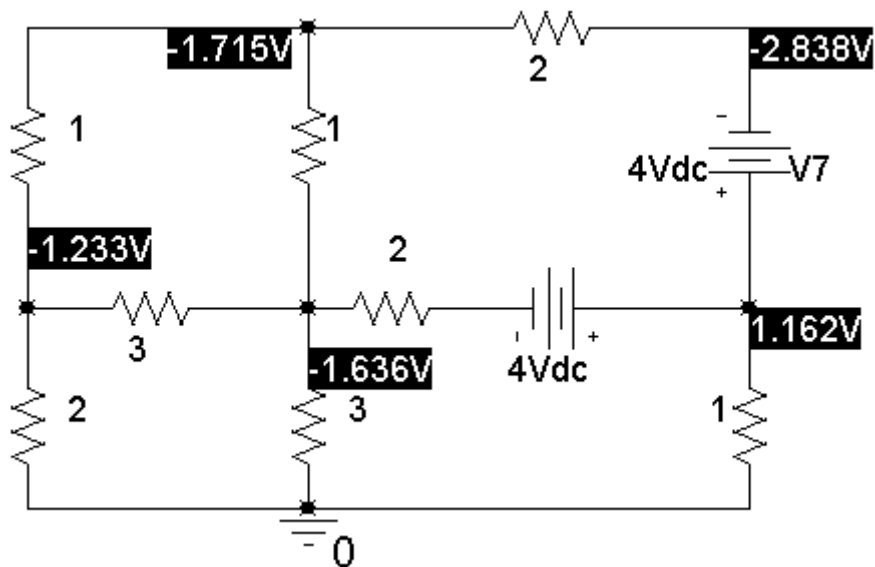

The PSpice output file:

VOLTAGE SOURCE CURRENTS	
NAME	CURRENT
V_V7	-5.613E-01
V_V8	-6.008E-01

The current of the voltage source labeled V7 is also the current of the 2Ω resistor at the top of the circuit. However this current is directed from right to left in the 2Ω resistor while the current i is directed from left to right. Consequently, $i = +5.613$ A.

Verification Problems

VP 4-1

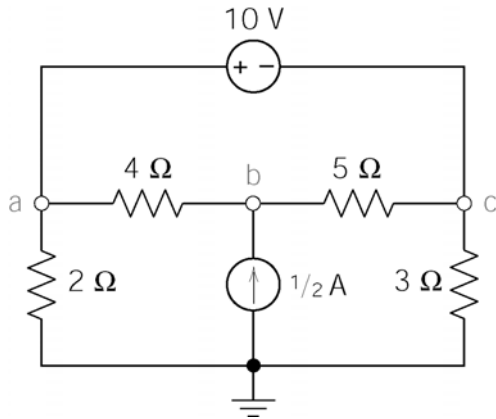

Apply KCL at node b :

$$\frac{v_b - v_a}{4} - \frac{1}{2} + \frac{v_b - v_c}{5} = 0$$

$$\frac{-4.8 - 5.2}{4} - \frac{1}{2} + \frac{-4.8 - 3.0}{5} \neq 0$$

The given voltages do not satisfy the KCL equation at node b . They are not correct.

VP 4-2

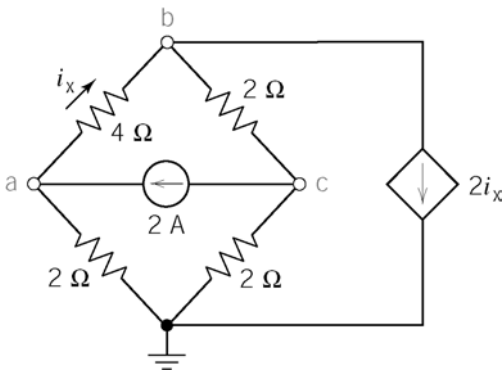

Apply KCL at node a :

$$-\left(\frac{v_b - v_a}{4}\right) - 2 + \frac{v_a}{2} = 0$$

$$-\left(\frac{20 - 4}{4}\right) - 2 + \frac{4}{2} = -4 \neq 0$$

The given voltages do not satisfy the KCL equation at node a . They are not correct.

VP 4-3

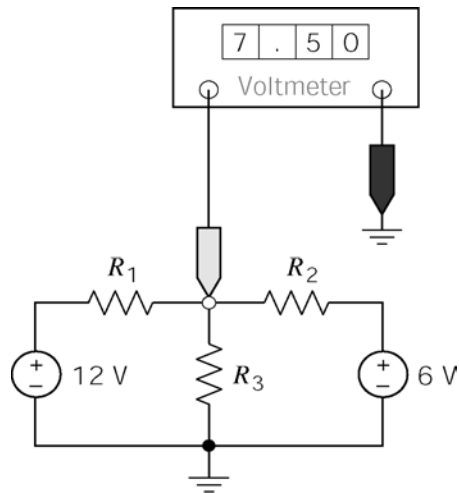

Writing a node equation:

$$-\left(\frac{12-7.5}{R_1}\right) + \frac{7.5}{R_3} + \frac{7.5-6}{R_2} = 0$$

so

$$-\frac{4.5}{R_1} + \frac{7.5}{R_3} + \frac{1.5}{R_2} = 0$$

There are only three cases to consider. Suppose $R_1 = 5 \text{ k}\Omega$ and $R_2 = R_3 = 10 \text{ k}\Omega$. Then

$$-\frac{4.5}{R_1} + \frac{7.5}{R_3} + \frac{1.5}{R_2} = \frac{-0.9 + 0.75 + 0.15}{1000} = 0$$

This choice of resistance values corresponds to branch currents that satisfy KCL. Therefore, it is indeed possible that two of the resistances are $10 \text{ k}\Omega$ and the other resistance is $5 \text{ k}\Omega$. The $5 \text{ k}\Omega$ is R_1 .

VP 4-4

KCL at node 1:

$$0 = \frac{v_1 - v_2}{20} + \frac{v_1}{5} + 1 \Rightarrow \frac{-8 - (-20)}{20} + \frac{-8}{5} + 1 = 0$$

KCL at node 2:

$$\begin{aligned} \frac{v_1 - v_2}{20} &= 2 + \frac{v_2 - v_3}{10} \Rightarrow \frac{-8 - (-20)}{20} = 2 + \frac{-20 - (-6)}{10} \\ &\Rightarrow \frac{12}{20} = \frac{6}{10} \end{aligned}$$

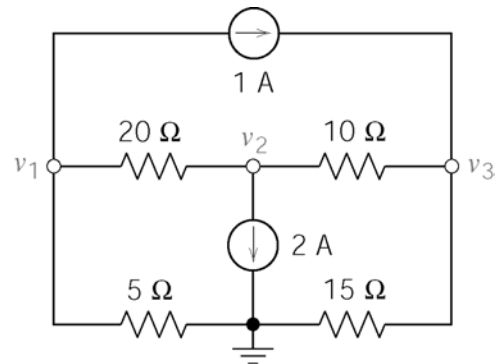

KCL at node 3: $\frac{v_2 - v_3}{10} + 1 = \frac{v_3}{15} \Rightarrow \frac{-20 - (-6)}{10} + 1 = \frac{-6}{15} \Rightarrow \frac{-4}{10} = \frac{-6}{15}$

KCL is satisfied at all of the nodes so the computer analysis is correct.

VP 4-5

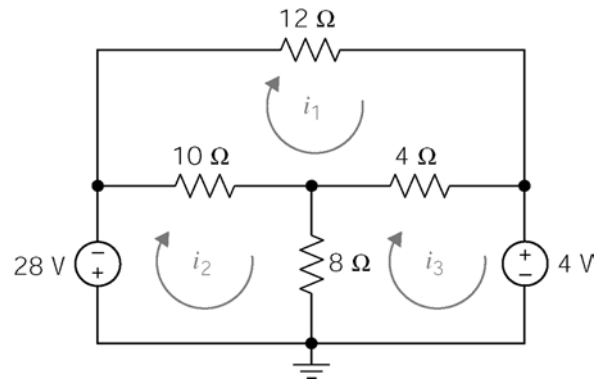

Top mesh: $10(2-4) + 12(2) + 4(2-3) = 0$

Bottom right mesh $8(3-4) + 4(3-2) + 4 = 0$

Bottom, left mesh: $28 + 10(4-2) + 8(4-3) \neq 0$ (Perhaps the polarity of the 28 V source was entered incorrectly.)

KVL is not satisfied for the bottom, left mesh so the computer analysis is not correct.

Design Problems

DP 4-1

Model the circuit as:

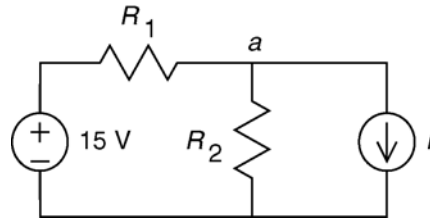

a)

We need to keep v_2 across R_2 as $4.8 \leq v_2 \leq 5.4$

For $I = \begin{cases} 0.3 \text{ A} & \text{display is active} \\ 0.1 \text{ A} & \text{display is not active} \end{cases}$

$$\text{KCL at a: } \frac{v_2 - 15}{R_1} + \frac{v_2}{R_2} + I = 0$$

Assumed that maximum I results in minimum v_2 and visa-versa.

Then

$$v_2 = \begin{cases} 4.8 \text{ V} & \text{when } I = 0.3 \text{ A} \\ 5.4 \text{ V} & \text{when } I = 0.1 \text{ A} \end{cases}$$

Substitute these corresponding values of v_2 and I into the KCL equation and solve for the resistances

$$\frac{4.8 - 15}{R_1} + \frac{4.8}{R_2} + 0.3 = 0$$

$$\frac{5.4 - 15}{R_1} + \frac{5.4}{R_2} + 0.1 = 0$$

$$\Rightarrow \underline{R_1 = 7.89 \Omega}, \underline{R_2 = 4.83 \Omega}$$

$$\text{b) } I_{R_1 \max} = \frac{15 - 4.8}{7.89} = 1.292 \text{ A} \Rightarrow P_{R_1 \max} = (1.292)^2 (7.89) = 13.17 \text{ W}$$

$$I_{R_2 \max} = \frac{5.4}{4.83} = 1.118 \text{ A} \Rightarrow P_{R_2 \max} = \frac{(5.4)^2}{4.83} = 6.03 \text{ W}$$

$$\text{maximum supply current} = I_{R_1 \max} = 1.292 \text{ A}$$

c) No; if the supply voltage (15V) were to rise or drop, the voltage at the display would drop below 4.8V or rise above 5.4V.

The power dissipated in the resistors is excessive. Most of the power from the supply is dissipated in the resistors, not the display.

DP 4-2

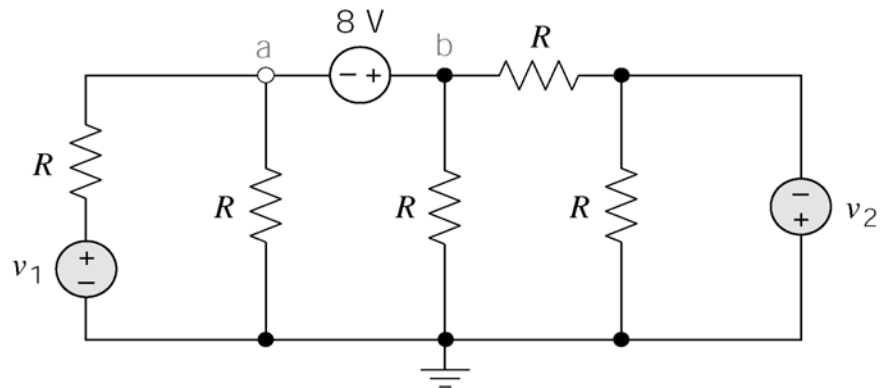

Express the voltage of the 8 V source in terms of its node voltages to get $v_b - v_a = 8$. Apply KCL to the supernode corresponding to the 8 V source:

$$\begin{aligned} \frac{v_a - v_1}{R} + \frac{v_a}{R} + \frac{v_b}{R} + \frac{v_b - (-v_2)}{R} &= 0 \Rightarrow 2v_a - v_1 + 2v_b + v_2 = 0 \\ &\Rightarrow 2v_a - v_1 + 2(v_a + 8) + v_2 = 0 \\ &\Rightarrow 4v_a - v_1 + v_2 + 16 = 0 \\ &\Rightarrow v_a = \frac{v_1 - v_2}{4} - 4 \end{aligned}$$

Next set $v_a = 0$ to get

$$0 = \frac{v_1 - v_2}{4} - 4 \Rightarrow v_1 - v_2 = 16 \text{ V}$$

For example, $v_1 = 18 \text{ V}$ and $v_2 = 2 \text{ V}$.

DP 4-3

a)

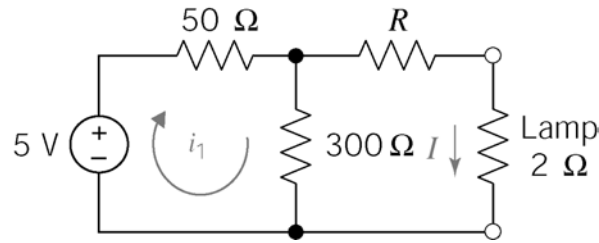

Apply KCL to left mesh: $-5 + 50i_1 + 300(i_1 - I) = 0$

Apply KCL to right mesh: $(R + 2)I + 300(I - i_1) = 0$

Solving for I:
$$I = \frac{150}{1570 + 35R}$$

We desire $50 \text{ mA} \leq I \leq 75 \text{ mA}$ so if $R = 100 \Omega$, then $I = 29.59 \text{ mA} \Rightarrow$ 1 amp so the lamp will not light.

b) From the equation for I , we see that decreasing R increases I :

try $R = 50 \Omega \Rightarrow I = 45 \text{ mA}$ (won't light)

try $R = 25 \Omega \Rightarrow I = 61 \text{ mA} \Rightarrow$ will light

Now check $R \pm 10\%$ to see if the lamp will light and not burn out:

$$\left. \begin{array}{l} -10\% \rightarrow 22.5\Omega \rightarrow I = 63.63 \text{ mA} \\ +10\% \rightarrow 27.5\Omega \rightarrow I = 59.23 \text{ mA} \end{array} \right\} \begin{array}{l} \text{lamp will} \\ \text{stay on} \end{array}$$

DP 4-4

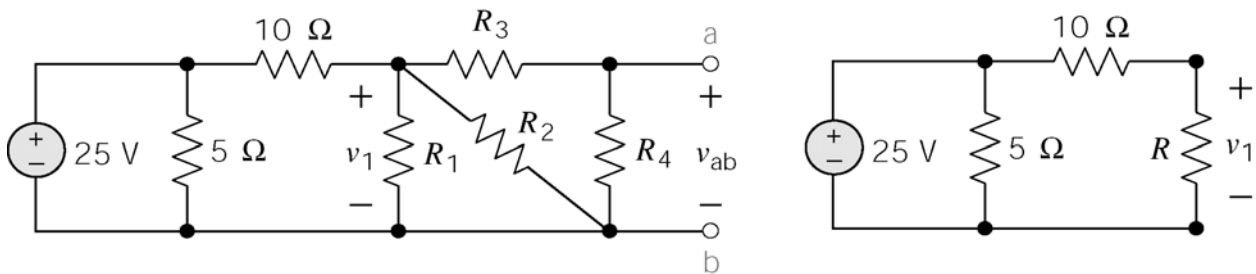

Equivalent resistance: $R = R_1 \parallel R_2 \parallel (R_3 + R_4)$

Voltage division in the equivalent circuit: $v_1 = \frac{R}{10 + R}(25)$

We require $v_{ab} = 10 \text{ V}$. Apply the voltage division principle in the left circuit to get:

$$10 = \frac{R_4}{R_3 + R_4} v_1 = \frac{R_4}{R_3 + R_4} \times \frac{(R_1 \parallel R_2 \parallel (R_3 + R_4))}{10 + (R_1 \parallel R_2 \parallel (R_3 + R_4))} \times 25$$

This equation does not have a unique solution. Here's one solution:

$$\text{choose } R_1 = R_2 = 25 \Omega \text{ and } R_3 + R_4 = 20 \Omega$$

$$\text{then } 10 = \frac{R_4}{20} \times \frac{(12.5 \parallel 20)}{10 + (12.5 \parallel 20)} \times 25 \Rightarrow \underline{R_4 = 18.4 \Omega}$$

$$\text{and } R_3 + R_4 = 20 \Rightarrow \underline{R_3 = 1.6 \Omega}$$

DP 4-5

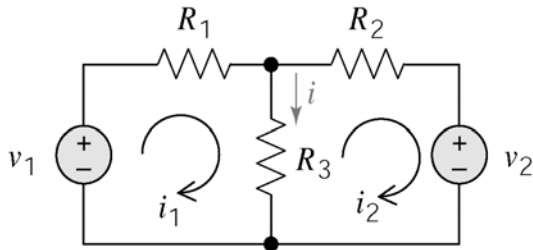

Apply KCL to the left mesh:

$$(R_1 + R_3) i_1 - R_3 i_2 - v_1 = 0$$

Apply KCL to the right mesh:

$$-R_3 i_1 + (R_2 + R_3) i_2 + v_2 = 0$$

Solving for the mesh currents using Cramer's rule:

$$i_1 = \frac{\begin{bmatrix} v_1 & -R_3 \\ -v_2 & (R_2 + R_3) \end{bmatrix}}{\Delta} \text{ and } i_2 = \frac{\begin{bmatrix} (R_1 + R_3) & v_1 \\ -R_3 & -v_2 \end{bmatrix}}{\Delta}$$

$$\text{where } \Delta = (R_1 + R_3)(R_2 + R_3) - R_3^2$$

Try $R_1 = R_2 = R_3 = 1 \text{ k}\Omega = 1000 \Omega$. Then $\Delta = 3 \text{ M}\Omega$. The mesh currents will be given by

$$i_1 = \frac{[2v_1 - v_2] 1000}{3 \times 10^6} \text{ and } i_2 = \frac{[-2v_2 + v_1] 1000}{3 \times 10^6} \Rightarrow i = i_1 - i_2 = \frac{v_1 + v_2}{3000}$$

Now check the extreme values of the source voltages:

$$\text{if } v_1 = v_2 = 1 \text{ V} \Rightarrow i = \frac{2}{3} \text{ mA} \quad \text{okay}$$

$$\text{if } v_1 = v_2 = 2 \text{ V} \Rightarrow i = \frac{4}{3} \text{ mA} \quad \text{okay}$$

Chapter 5 Circuit Theorems

Exercises

Ex 5.3-1

$$R = 10 \Omega \text{ and } i_s = 1.2 \text{ A.}$$

Ex 5.3-2

$$R = 10 \Omega \text{ and } i_s = -1.2 \text{ A.}$$

Ex 5.3-3

$$R = 8 \Omega \text{ and } v_s = 24 \text{ V.}$$

Ex 5.3-4

$$R = 8 \Omega \text{ and } v_s = -24 \text{ V.}$$

Ex 5.4-1

$$v_m = \frac{20}{10+20+20}(15) + 20 \left[-\frac{10}{10+(20+20)}(2) \right] = 6 + 20\left(-\frac{2}{5}\right) = -2 \text{ V}$$

Ex 5.4-2

$$i_m = \frac{25}{3+2} - \frac{3}{2+3}(5) = 5 - 3 = 2 \text{ A}$$

Ex 5.4-3

$$v_m = 3 \left[\frac{3}{3+(3+3)}(5) \right] - \frac{3}{3+(3+3)}(18) = 5 - 6 = -1 \text{ A}$$

Ex 5.5-1

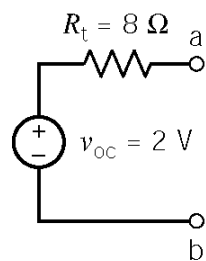
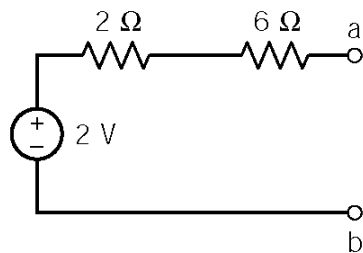
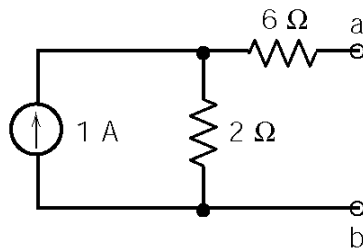
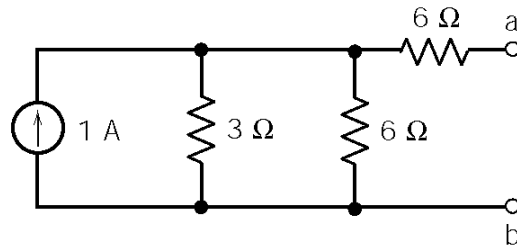
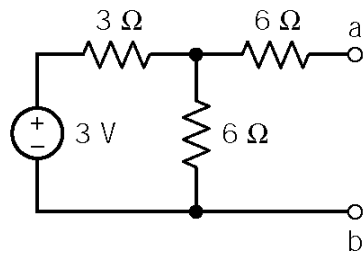

Ex 5.5-2

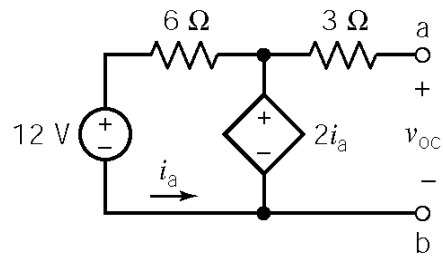

$$i_a = \frac{2i_a - 12}{6} \Rightarrow i_a = -3 \text{ A}$$

$$v_{oc} = 2i_a = -6 \text{ V}$$

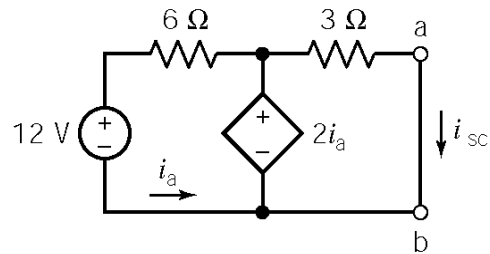

$$12 + 6i_a = 2i_a \Rightarrow i_a = -3 \text{ A}$$

$$3i_{sc} = 2i_a \Rightarrow i_{sc} = \frac{2}{3}(-3) = -2 \text{ A}$$

$$R_t = \frac{-6}{-2} = 3 \Omega$$

Ex 5.6-1

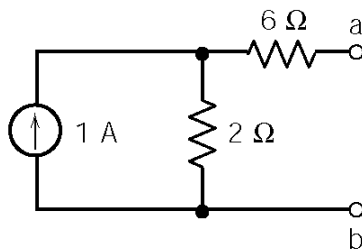
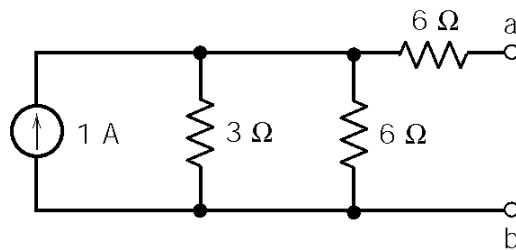
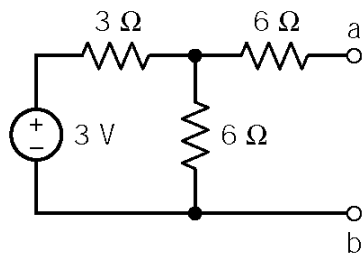

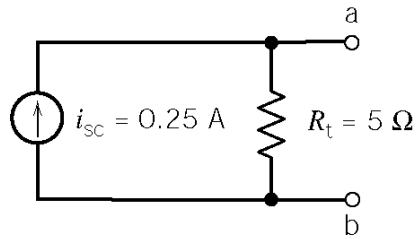
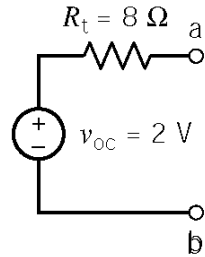
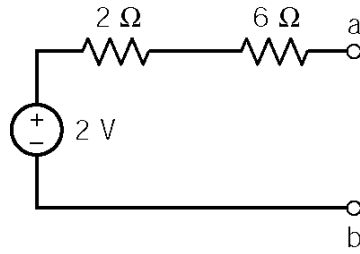

Ex 5.6-2

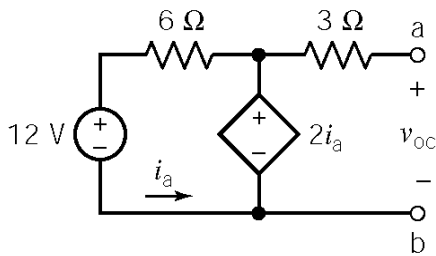

$$i_a = \frac{2i_a - 12}{6} \Rightarrow i_a = -3 \text{ A}$$

$$v_{oc} = 2i_a = -6 \text{ V}$$

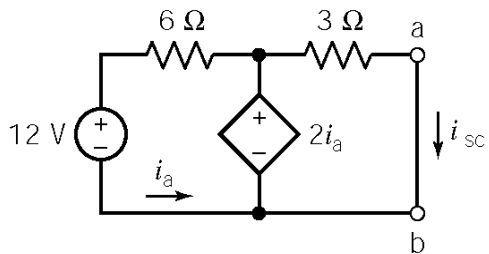

$$12 + 6i_a = 2i_a \Rightarrow i_a = -3 \text{ A}$$

$$3i_{sc} = 2i_a \Rightarrow i_{sc} = \frac{2}{3}(-3) = -2 \text{ A}$$

$$R_t = \frac{-6}{-2} = 3 \Omega$$

Ex 5.6-3

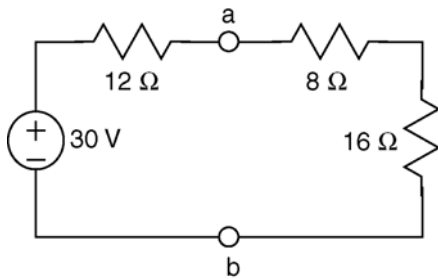

$$R_t = \frac{12 \times 24}{12 + 24} = \frac{12 \times 24}{36} = 8 \Omega$$

$$v_{oc} = \frac{24}{12 + 24} (30) = 20 \text{ V}$$

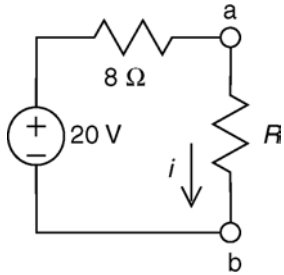

$$i = \frac{20}{8 + R}$$

Ex 5.7-1

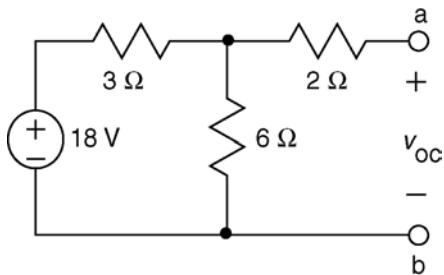

$$v_{oc} = \frac{6}{6 + 3} (18) = 12 \text{ V}$$

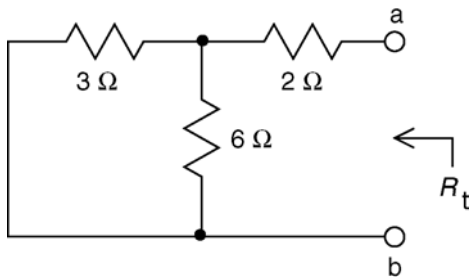

$$R_t = 2 + \frac{(3)(6)}{3 + 6} = 4 \Omega$$

For maximum power, we require

$$R_L = R_t = 4 \Omega$$

Then

$$p_{\max} = \frac{v_{oc}^2}{4 R_t} = \frac{12^2}{4(4)} = 9 \text{ W}$$

Ex 5.7-2

$$i_{sc} = \frac{\frac{1}{3}}{\frac{1}{3} + \frac{1}{150} + \frac{1}{30}} (5.6) = \frac{50}{50+1+5} (5.6) = 5 \text{ A}$$

$$R_t = 3 + \frac{150(30)}{150+30} = 3 + 25 = 28 \Omega$$

$$p_{\max} = \frac{R_t i_{sc}^2}{4} = \frac{(28)5^2}{4} = 175 \text{ W}$$

Ex 5.7-3

$$p = i v = \left(\frac{10}{R_t + R_L} \right) \left[\frac{R_L}{R_t + R_L} (10) \right] = \frac{100 R_L}{(R_t + R_L)^2}$$

The power increases as R_t decreases so choose $R_t = 1 \Omega$. Then

$$p_{\max} = i v = \frac{100(5)}{(1+5)^2} = 13.9 \text{ W}$$

Ex 5.7-4

From the plot, the maximum power is 5 W when $R = 20 \Omega$. Therefore:

$$R_t = 20 \Omega$$

and

$$p_{\max} = \frac{v_{oc}^2}{4 R_t} \Rightarrow v_{oc} = \sqrt{p_{\max} 4 R_t} = \sqrt{5(4)20} = 20 \text{ V}$$

Problems

Section 5-3: Source Transformations

P5.3-1

(a)

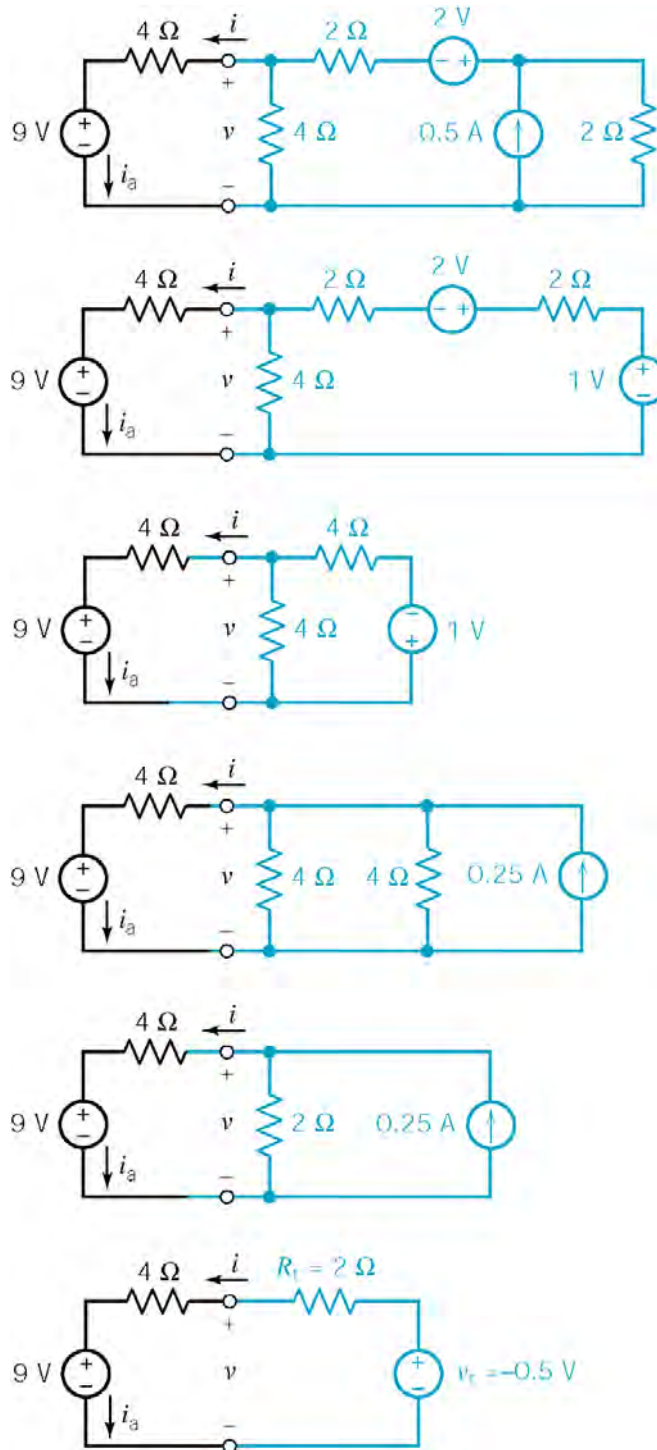

$$\therefore R_t = 2 \Omega$$

$$v_t = -0.5 \text{ V}$$

(b) $-9 - 4i - 2i + (-0.5) = 0$

$$i = \frac{-9 + (-0.5)}{4 + 2} = -1.58 \text{ A}$$

$$v = 9 + 4i = 9 + 4(-1.58) = 2.67 \text{ V}$$

(c) $i_a = i = -1.58 \text{ A}$

(checked using LNAP 8/15/02)

P5.3-2

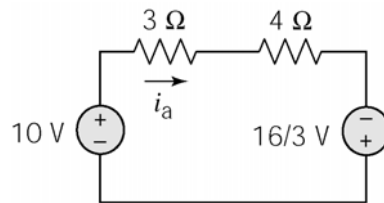
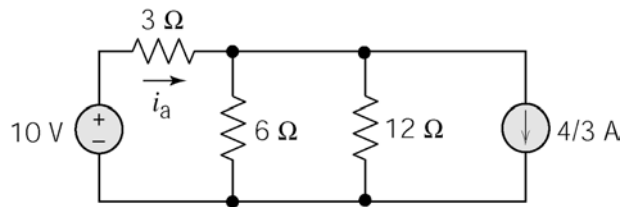
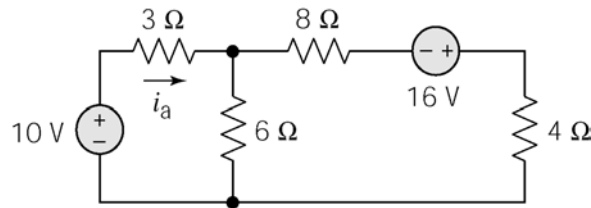
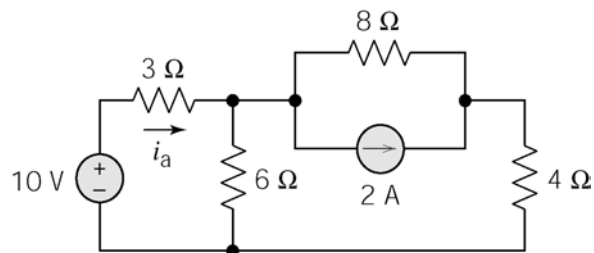

Finally, apply KVL: $-10 + 3i_a + 4i_a - \frac{16}{3} = 0 \quad \therefore \underline{i_a = 2.19 \text{ A}}$

(checked using LNAP 8/15/02)

P5.3-3

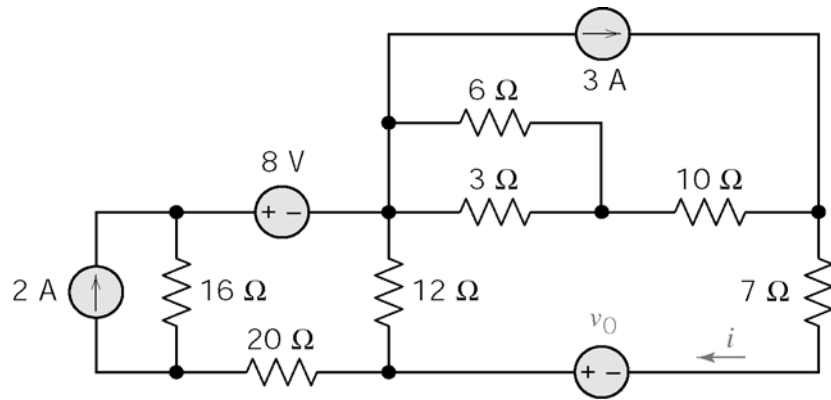

Source transformation at left; equivalent resistor for parallel 6 and 3 Ω resistors:

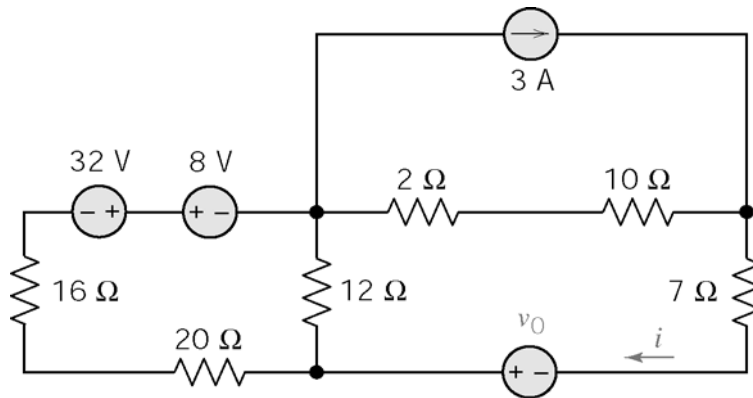

Equivalents for series resistors, series voltage source at left; series resistors, then source transformation at top:

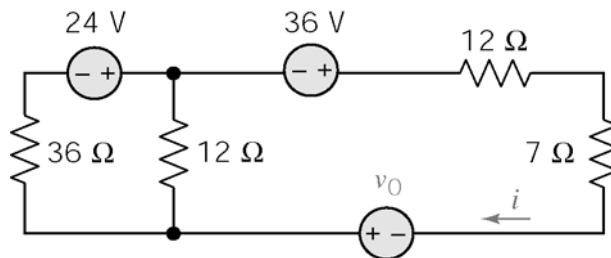

Source transformation at left; series resistors at right:

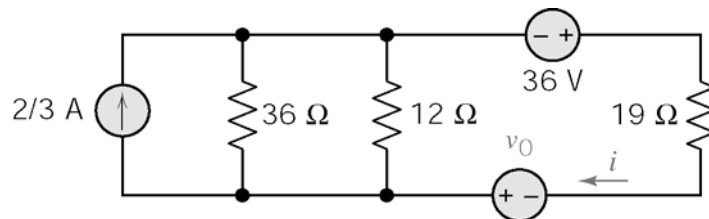

Parallel resistors, then source transformation at left:

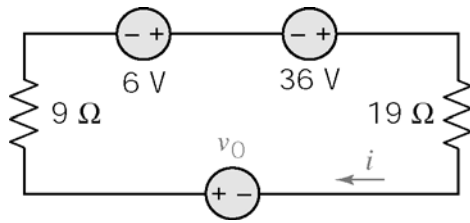

Finally, apply KVL to loop

$$-6 + i(9 + 19) - 36 - v_o = 0$$

$$i = 5/2 \Rightarrow v_o = -42 + 28(5/2) = 28 \text{ V}$$

(checked using LNAP 8/15/02)

P5.3-4

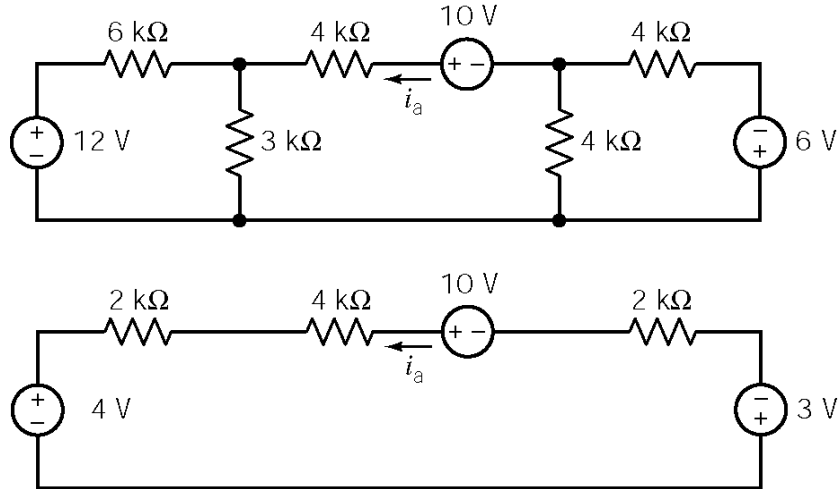

$$-4 - 2000 i_a - 4000 i_a + 10 - 2000 i_a - 3 = 0$$

$$\therefore i_a = 375 \mu\text{A}$$

(checked using LNAP 8/15/02)

P5.3-5

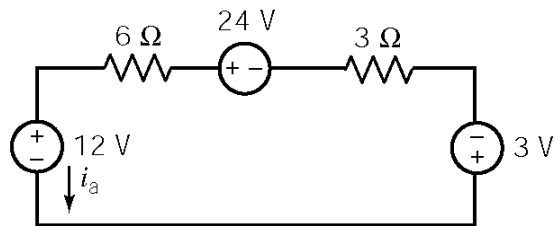
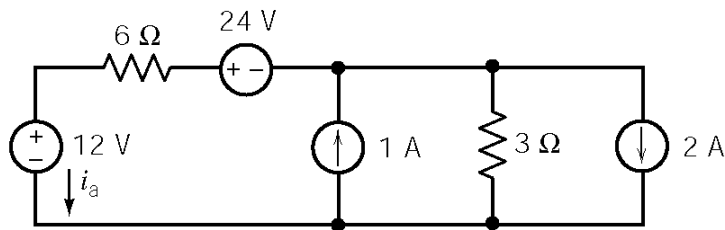
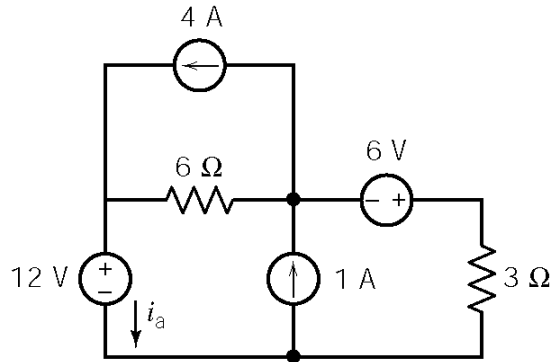

$$-12 - 6i_a + 24 - 3i_a - 3 = 0 \Rightarrow i_a = 1 \text{ A}$$

(checked using LNAP 8/15/02)

P5.3-6

A source transformation on the right side of the circuit, followed by replacing series resistors with an equivalent resistor:

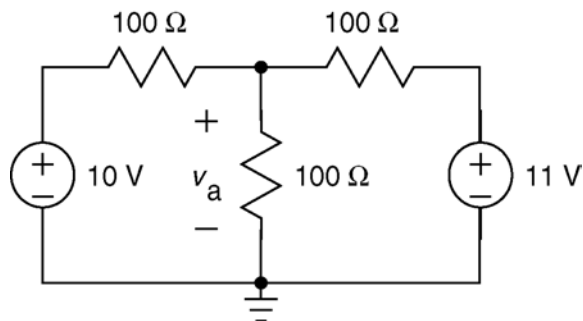

Source transformations on both the right side and the left side of the circuit:

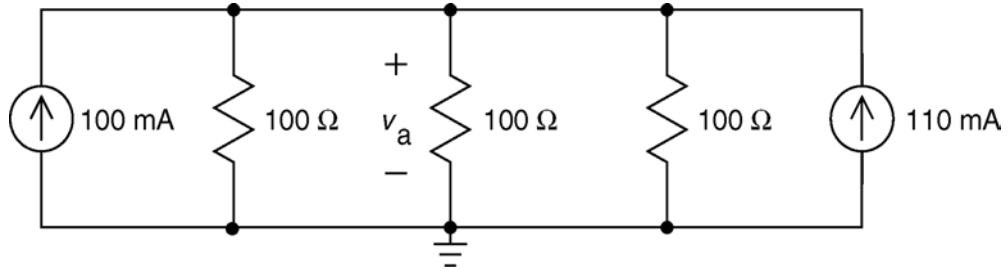

Replacing parallel resistors with an equivalent resistor and also replacing parallel current sources with an equivalent current source:

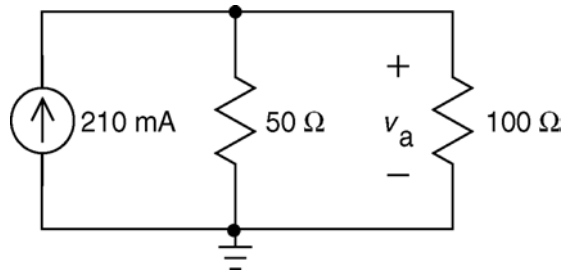

Finally,

$$v_a = \frac{50(100)}{50+100}(0.21) = \frac{100}{3}(0.21) = 7 \text{ V}$$

(checked using LNAP 8/15/02)

Section 5-4 Superposition

P5.4-1

Consider 6 A source only (open 9 A source)

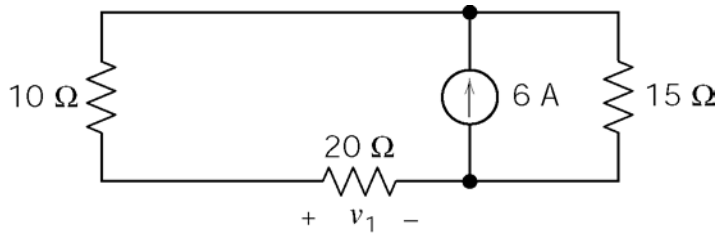

Use current division:

$$\frac{v_1}{20} = 6 \left[\frac{15}{15 + 30} \right] \Rightarrow \underline{v_1 = 40 \text{ V}}$$

Consider 9 A source only (open 6 A source)

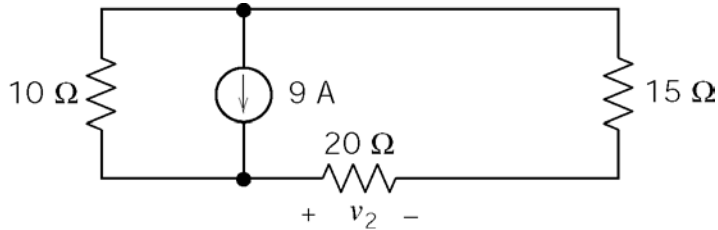

Use current division:

$$\frac{v_2}{20} = 9 \left[\frac{10}{10 + 35} \right] \Rightarrow \underline{v_2 = 40 \text{ V}}$$

$$\therefore \underline{v = v_1 + v_2 = 40 + 40 = 80 \text{ V}}$$

(checked using LNAP 8/15/02)

P5.4-2

Consider 12 V source only (open both current sources)

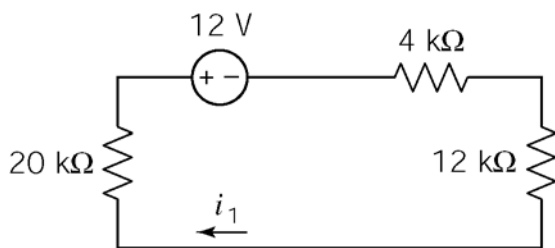

KVL:

$$20 i_1 + 12 + 4 i_1 + 12 i_1 = 0 \\ \Rightarrow \underline{i_1 = -1/3 \text{ mA}}$$

Consider 3 mA source only (short 12 V and open 9 mA sources)

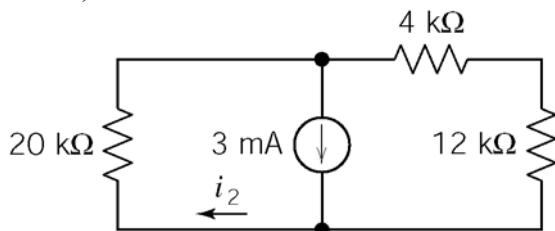

Current Division:

$$i_2 = 3 \left[\frac{16}{16 + 20} \right] = \underline{\frac{4}{3} \text{ mA}}$$

Consider 9 mA source only (short 12 V and open 3 mA sources)

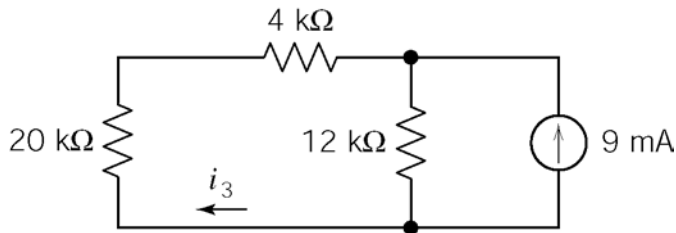

Current Division:

$$i_3 = -9 \left[\frac{12}{24+12} \right] = \underline{-3 \text{ mA}}$$

$$\therefore i = i_1 + i_2 + i_3 = -1/3 + 4/3 - 3 = \underline{-2 \text{ mA}}$$

(checked using LNAP 8/15/02)

P5.4-3

Consider 30 mA source only (open 15 mA and short 15 V sources). Let i_1 be the part of i due to the 30 mA current source.

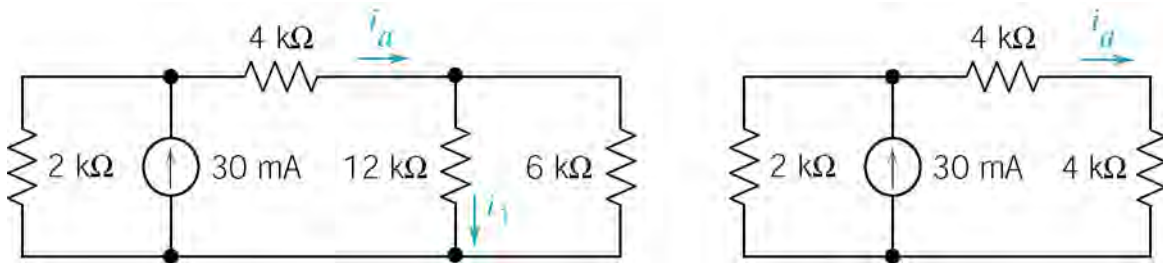

$$i_a = 30 \left(\frac{2}{2+8} \right) = 6 \text{ mA} \Rightarrow i_1 = i_a \left(\frac{6}{6+12} \right) = \underline{2 \text{ mA}}$$

Consider 15 mA source only (open 30 mA source and short 15 V source) Let i_2 be the part of i due to the 15 mA current source.

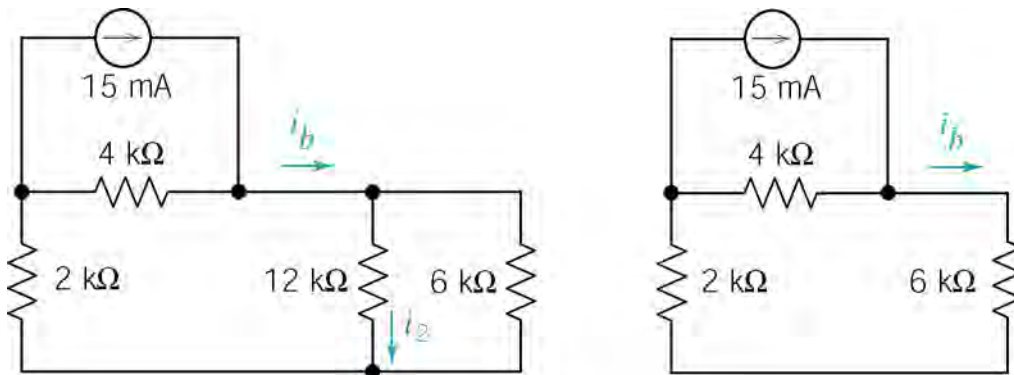

$$i_b = 15 \left(\frac{4}{4+6} \right) = 6 \text{ mA} \Rightarrow i_2 = i_b \left(\frac{6}{6+12} \right) = \underline{2 \text{ mA}}$$

Consider 15 V source only (open both current sources). Let i_3 be the part of i due to the 15 V voltage source.

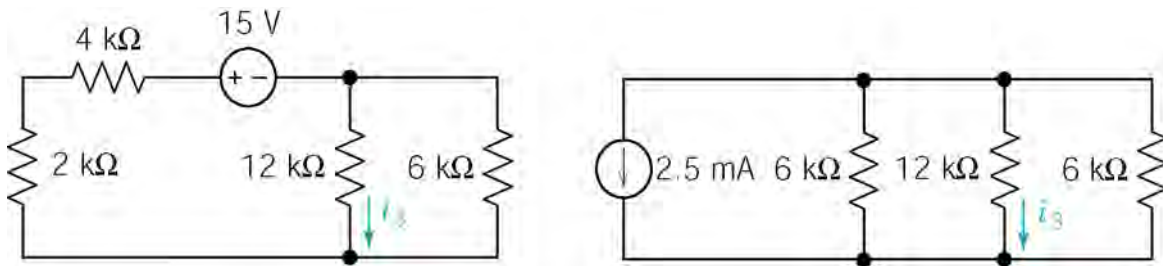

$$i_3 = -2.5 \left(\frac{6 \parallel 6}{(6 \parallel 6) + 12} \right) = -10 \left(\frac{3}{3 + 12} \right) = \underline{-0.5 \text{ mA}}$$

Finally, $i = i_1 + i_2 + i_3 = 2 + 2 - 0.5 = 3.5 \text{ mA}$

(checked using LNAP 8/15/02)

P5.4-4

Consider 10 V source only (open 30 mA source and short the 8 V source)

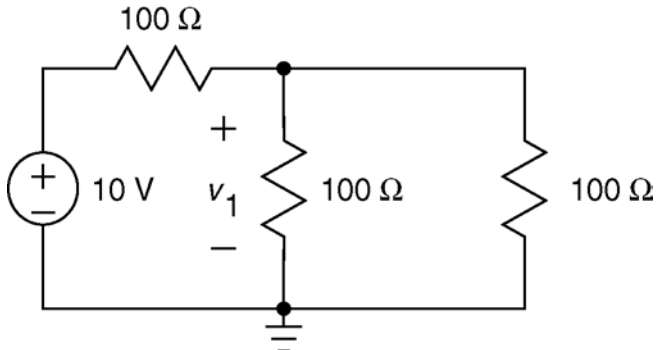

Let v_1 be the part of v_a due to the 10 V voltage source.

$$\begin{aligned} v_1 &= \frac{100 \parallel 100}{(100 \parallel 100) + 100} (10) \\ &= \frac{50}{150} (10) = \frac{10}{3} \text{ V} \end{aligned}$$

Consider 8 V source only (open 30 mA source and short the 10 V source)

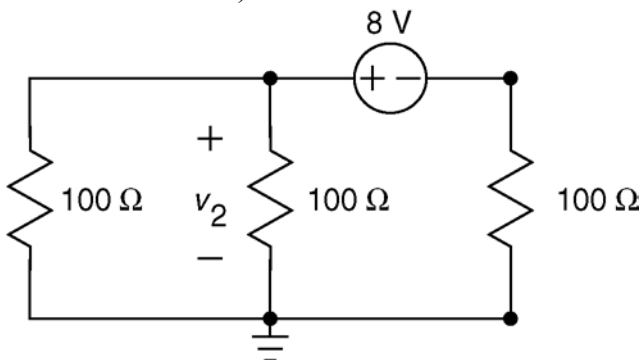

Let v_2 be the part of v_a due to the 8 V voltage source.

$$\begin{aligned} v_2 &= \frac{100 \parallel 100}{(100 \parallel 100) + 100} (8) \\ &= \frac{50}{150} (8) = \frac{8}{3} \text{ V} \end{aligned}$$

Consider 30 mA source only (short both the 10 V source and the 8 V source)

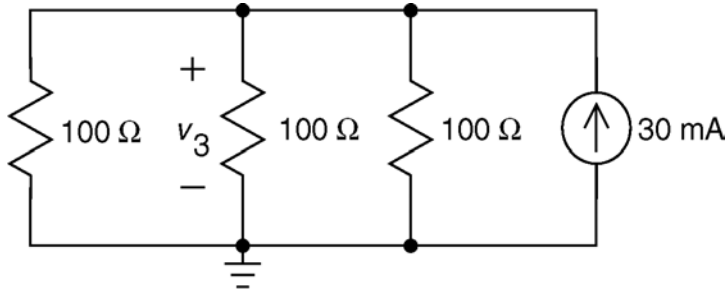

Let v_2 be the part of v_a due to the 30 mA current source.

$$v_3 = (100 \parallel 100 \parallel 100)(0.03) \\ = \frac{100}{3}(0.03) = 1 \text{ V}$$

Finally,
$$v_a = v_1 + v_2 + v_3 = \frac{10}{3} + \frac{8}{3} + 1 = 7 \text{ V}$$

(checked using LNAP 8/15/02)

P5.4-5

Consider 8 V source only (open the 2 A source)

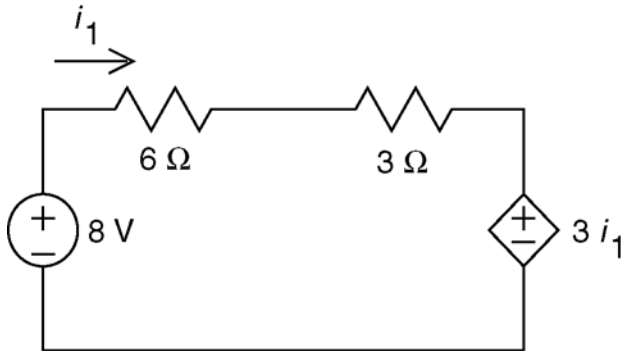

Let i_1 be the part of i_x due to the 8 V voltage source.

Apply KVL to the supermesh:

$$6(i_1) + 3(i_1) + 3(i_1) - 8 = 0 \\ i_1 = \frac{8}{12} = \frac{2}{3} \text{ A}$$

Consider 2 A source only (short the 8 V source)

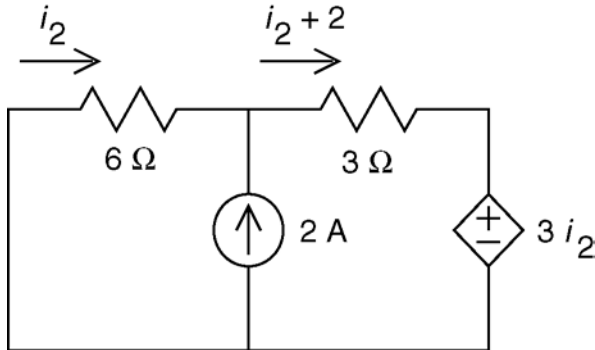

Let i_2 be the part of i_x due to the 2 A current source.

Apply KVL to the supermesh:

$$6(i_2) + 3(i_2 + 2) + 3i_2 = 0 \\ i_2 = \frac{-6}{12} = -\frac{1}{2} \text{ A}$$

Finally,
$$i_x = i_1 + i_2 = \frac{2}{3} - \frac{1}{2} = \frac{1}{6} \text{ A}$$

Section 5-5: Thévenin's Theorem

P5.5-1

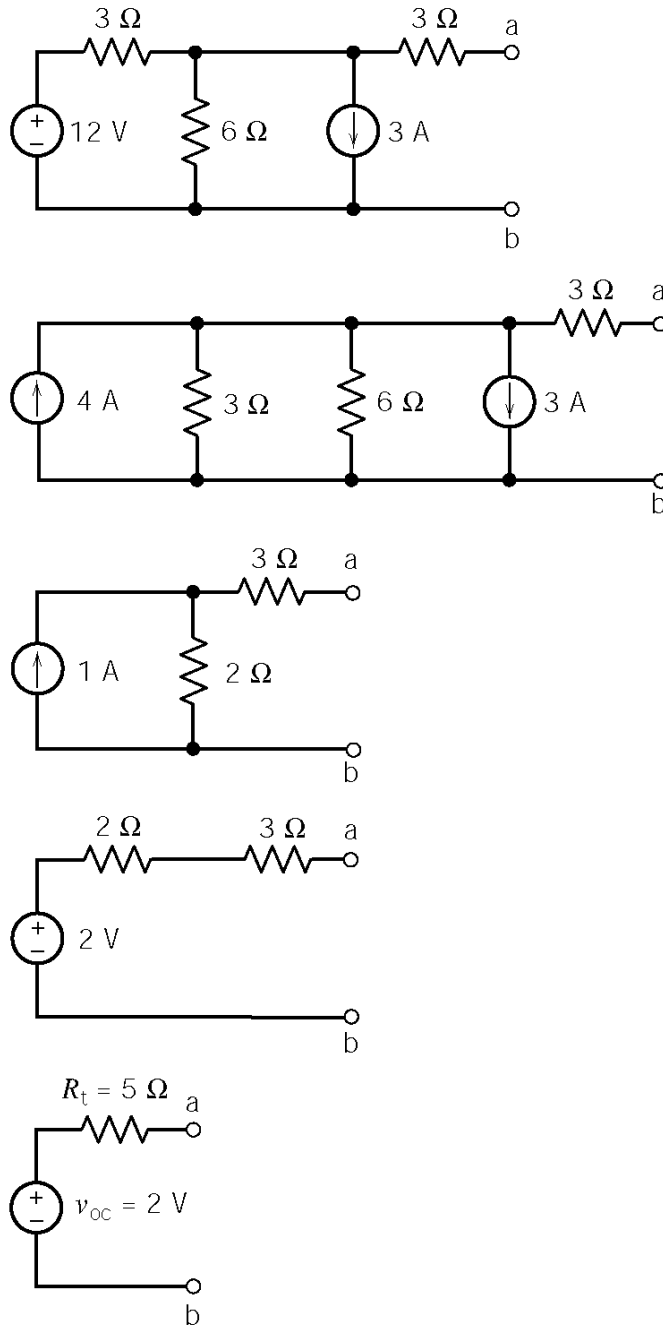

(checked using LNAP 8/15/02)

P5.5-2

The circuit from Figure P5.5-2a can be reduced to its Thevenin equivalent circuit in four steps:

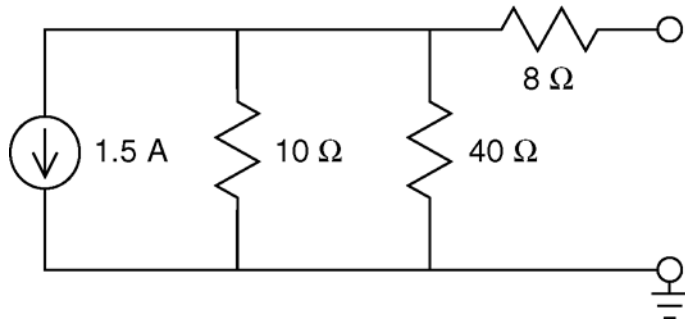

(a)

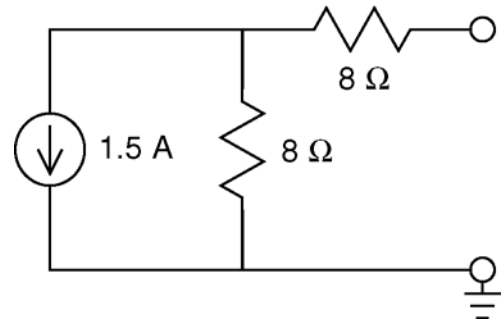

(b)

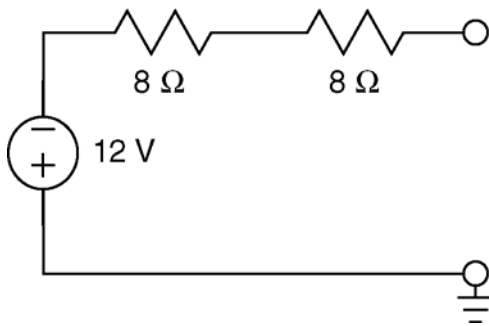

(c)

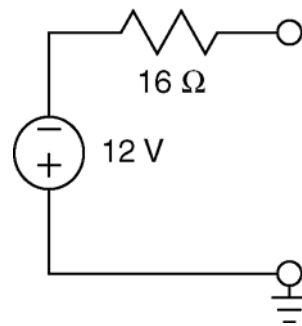

(d)

Comparing (d) to Figure P5.5-2b shows that the Thevenin resistance is $R_t = 16 \Omega$ and the open circuit voltage, $v_{oc} = -12 \text{ V}$.

P5.5-3

The circuit from Figure P5.5-3a can be reduced to its Thevenin equivalent circuit in five steps:

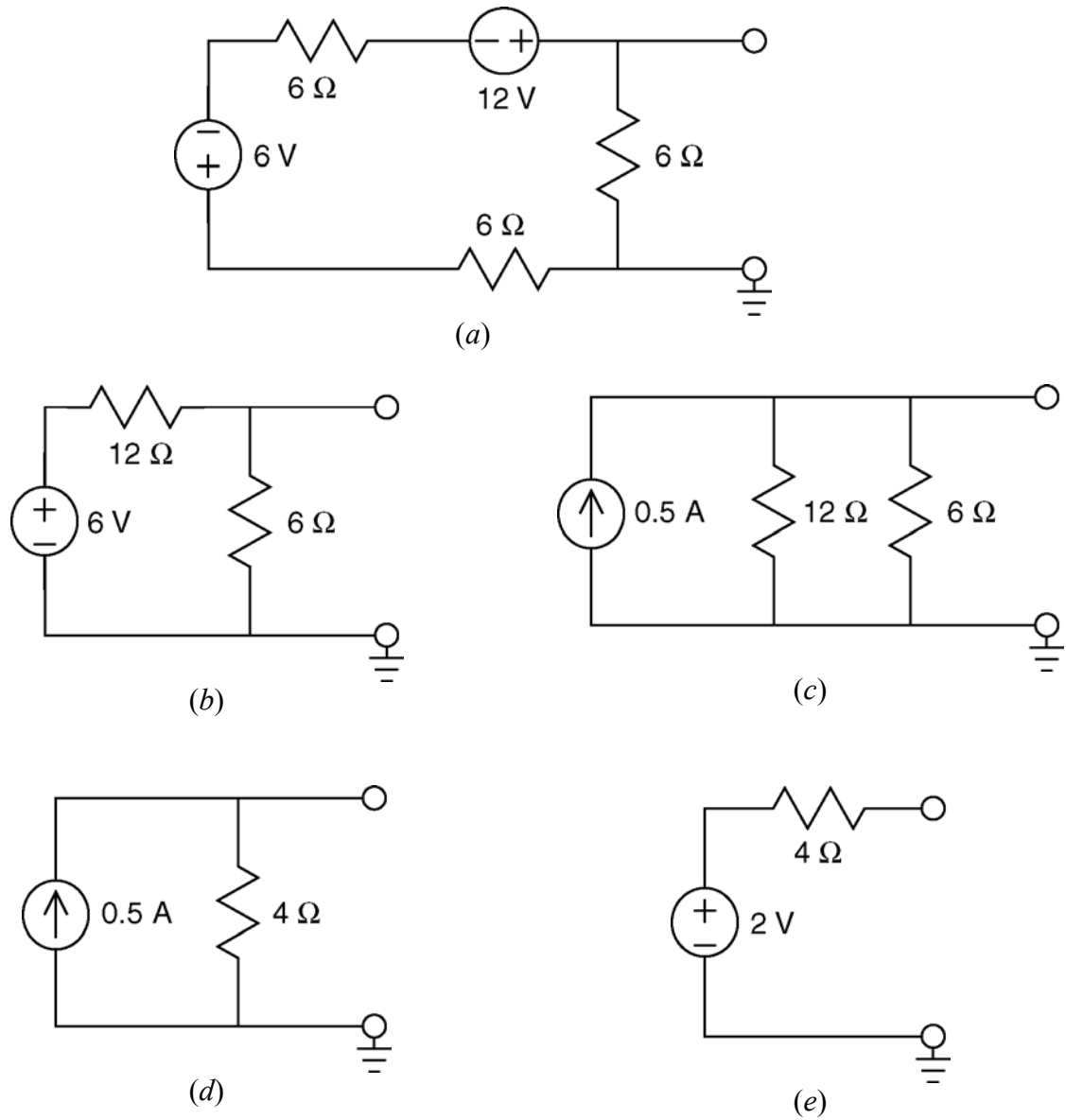

Comparing (e) to Figure P5.5-3b shows that the Thevenin resistance is $R_t = 4 \Omega$ and the open circuit voltage, $v_{oc} = 2 \text{ V}$.

(checked using LNAP 8/15/02)

P5.5-4
Find R_t :

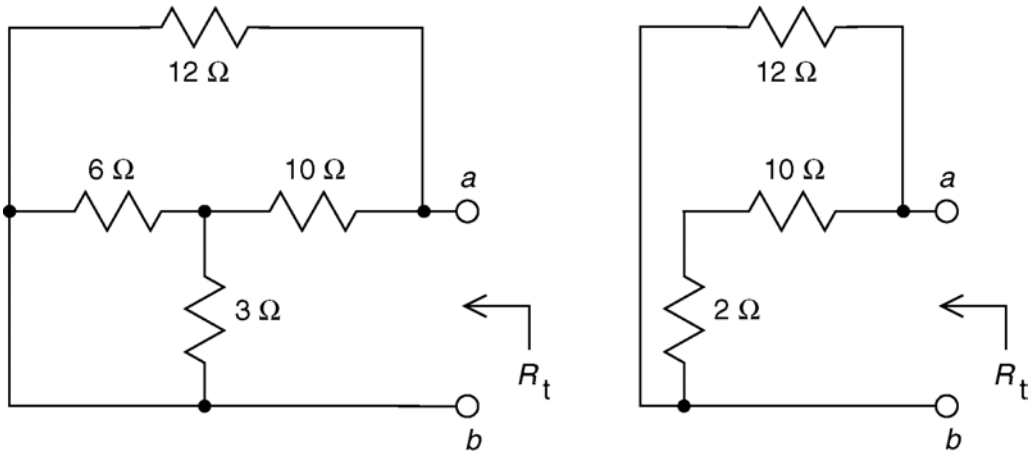

$$R_t = \frac{12(10+2)}{12+(10+2)} = 6 \Omega$$

Write mesh equations to find v_{oc} :

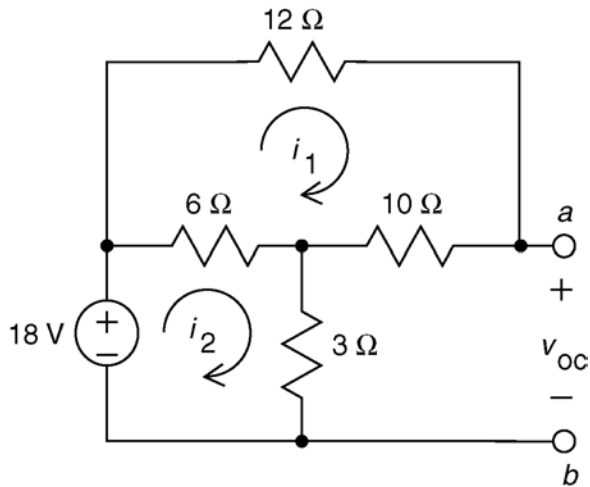

Mesh equations:

$$12 i_1 + 10 i_1 - 6(i_2 - i_1) = 0$$

$$6(i_2 - i_1) + 3 i_2 - 18 = 0$$

$$28 i_1 = 6 i_2$$

$$9 i_2 - 6 i_1 = 18$$

$$36 i_1 = 18 \Rightarrow i_1 = \frac{1}{2} \text{ A}$$

$$i_2 = \frac{14}{3} \left(\frac{1}{2} \right) = \frac{7}{3} \text{ A}$$

Finally,
$$v_{oc} = 3 i_2 + 10 i_1 = 3 \left(\frac{7}{3} \right) + 10 \left(\frac{1}{2} \right) = 12 \text{ V}$$

(checked using LNAP 8/15/02)

P5.5-5

Find v_{oc} :

Notice that v_{oc} is the node voltage at node a. Express the controlling voltage of the dependent source as a function of the node voltage:

$$v_a = -v_{oc}$$

Apply KCL at node a:

$$-\left(\frac{6-v_{oc}}{8}\right) + \frac{v_{oc}}{4} + \left(-\frac{3}{4}v_{oc}\right) = 0$$

$$-6 + v_{oc} + 2v_{oc} - 6v_{oc} = 0 \Rightarrow v_{oc} = -2 \text{ V}$$

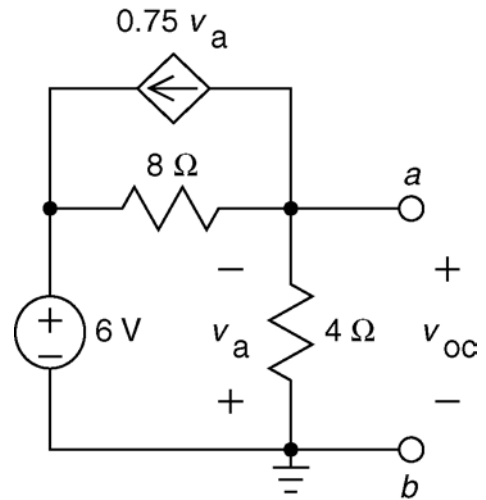

Find R_t :

We'll find i_{sc} and use it to calculate R_t . Notice that the short circuit forces

$$v_a = 0$$

Apply KCL at node a:

$$-\left(\frac{6-0}{8}\right) + \frac{0}{4} + \left(-\frac{3}{4} \cdot 0\right) + i_{sc} = 0$$

$$i_{sc} = \frac{6}{8} = \frac{3}{4} \text{ A}$$

$$R_t = \frac{v_{oc}}{i_{sc}} = \frac{-2}{3/4} = -\frac{8}{3} \Omega$$

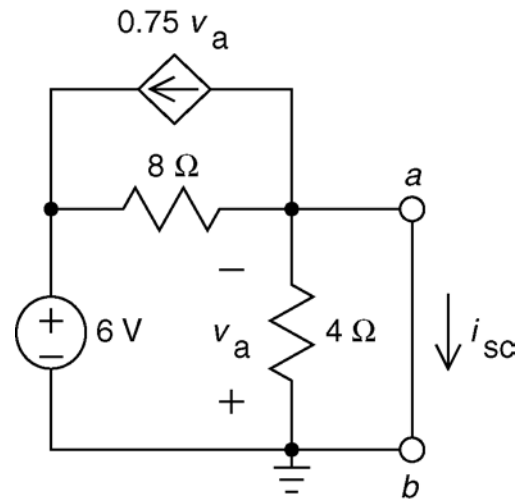

(checked using LNAP 8/15/02)

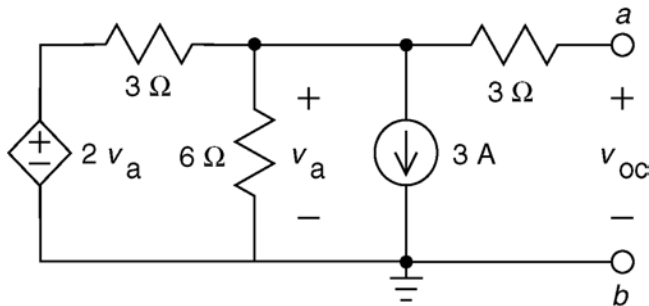
P5.5-6Find v_{oc} :

Apply KCL at the top, middle node: $\frac{2v_a - v_a}{3} = \frac{v_a}{6} + 3 + 0 \Rightarrow v_a = 18 \text{ V}$

The voltage across the right-hand 3Ω resistor is zero so: $v_a = v_{oc} = 18 \text{ V}$

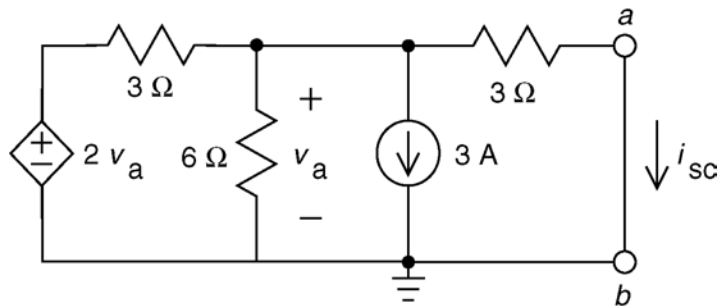
Find i_{sc} :

Apply KCL at the top, middle node: $\frac{2v_a - v_a}{3} = \frac{v_a}{6} + 3 + \frac{v_a}{3} \Rightarrow v_a = -18 \text{ V}$

Apply Ohm's law to the right-hand 3Ω resistor: $i_{sc} = \frac{v_a}{3} = \frac{-18}{3} = -6 \text{ V}$

Finally: $R_t = \frac{v_{oc}}{i_{sc}} = \frac{18}{-6} = -3 \Omega$

(checked using LNAP 8/15/02)

P5.5-7

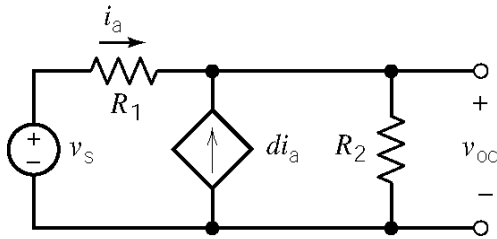

(a)

$$-v_s + R_1 i_a + (d+1)R_2 i_a = 0$$

$$i_a = \frac{v_s}{R_1 + (d+1)R_2}$$

$$v_{oc} = \frac{(d+1)R_2 v_s}{R_1 + (d+1)R_2}$$

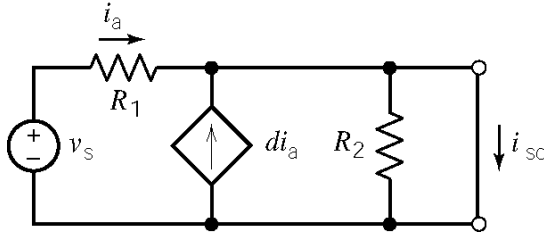

$$i_a = \frac{v_s}{R_1}$$

$$i_{sc} = (d+1)i_a = \frac{(d+1)v_s}{R_1}$$

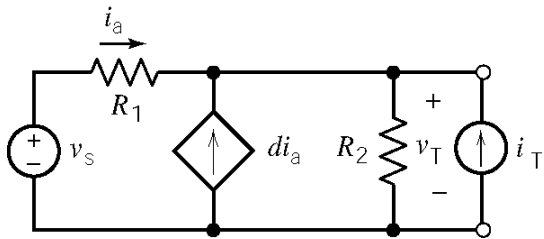

$$-i_a - d i_a + \frac{v_T}{R_2} - i_T = 0$$

$$R_1 i_a = -v_T$$

$$i_T = (d+1)\frac{v_T}{R_1} + \frac{v_T}{R_2} = \frac{R_2(d+1) + R_1}{R_1 R_2} \times v_T$$

$$R_t = \frac{v_T}{i_T} = \frac{R_1 R_2}{R_1 + (d+1)R_2}$$

(b) Let $R_1 = R_2 = 1 \text{ k}\Omega$. Then

$$625 \Omega = R_t = \frac{1000}{d+2} \Rightarrow d = \frac{1000}{625} - 2 = -0.4 \text{ A/A}$$

and

$$5 = v_{oc} = \frac{(d+1)v_s}{d+2} \Rightarrow v_s = \frac{-0.4+2}{-0.4+1} 5 = 13.33 \text{ V}$$

(checked using LNAP 8/15/02)

P5.5-8

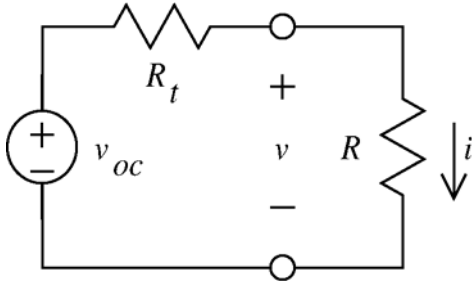

$$v = \frac{R}{R_t + R} v_{oc}$$

From the given data:

$$\left. \begin{aligned} 6 &= \frac{2000}{R_t + 2000} v_{oc} \\ 2 &= \frac{4000}{R_t + 4000} v_{oc} \end{aligned} \right\} \Rightarrow \begin{cases} v_{oc} = 1.2 \text{ V} \\ R_t = -1600 \Omega \end{cases}$$

When $R = 8000 \Omega$,

$$v = \frac{8000}{-1600 + 8000} (1.2) = 1.5 \text{ V}$$

P5.5-9

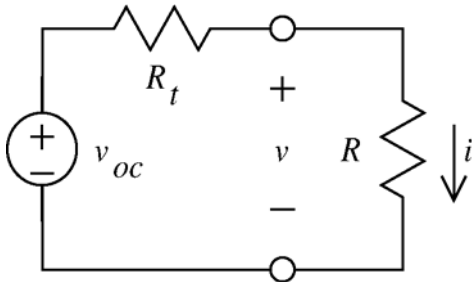

$$i = \frac{v_{oc}}{R_t + R}$$

From the given data:

$$\left. \begin{aligned} 0.004 &= \frac{v_{oc}}{R_t + 2000} \\ 0.003 &= \frac{v_{oc}}{R_t + 4000} \end{aligned} \right\} \Rightarrow \begin{cases} v_{oc} = 24 \text{ V} \\ R_t = 4000 \Omega \end{cases}$$

(a) When $i = 0.002 \text{ A}$:

$$0.002 = \frac{24}{4000 + R} \Rightarrow R = 8000 \Omega$$

(b) Maximum i occurs when $R = 0$:

$$\frac{24}{4000} = 0.006 = 6 \text{ mA} \Rightarrow i \leq 6 \text{ mA}$$

P5.5-10

The current at the point on the plot where $v = 0$ is the short circuit current, so $i_{sc} = 20 \text{ mA}$.

The voltage at the point on the plot where $i = 0$ is the open circuit voltage, so $v_{oc} = -3 \text{ V}$.

The slope of the plot is equal to the negative reciprocal of the Thevenin resistance, so

$$-\frac{1}{R_t} = \frac{0 - 0.002}{-3 - 0} \Rightarrow R_t = -150 \Omega$$

P5.5-11

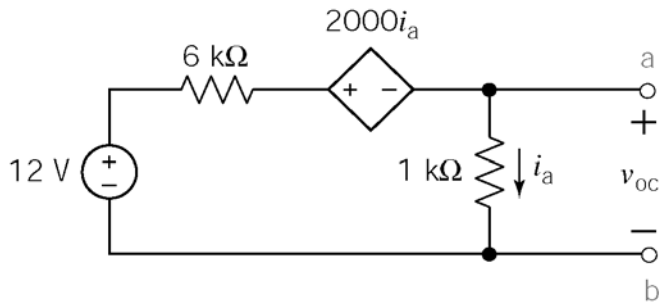

$$-12 + 6000i_a + 2000i_a + 1000i_a = 0$$

$$i_a = 4/3000 \text{ A}$$

$$v_{oc} = 1000 i_a = \frac{4}{3} \text{ V}$$

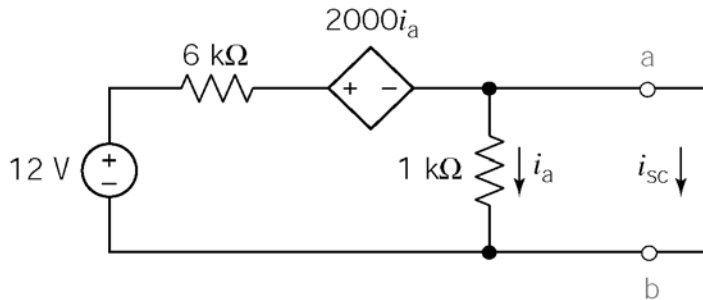

$i_a = 0$ due to the short circuit

$$-12 + 6000i_{sc} = 0 \Rightarrow i_{sc} = 2 \text{ mA}$$

$$R_t = \frac{v_{oc}}{i_{sc}} = \frac{\frac{4}{3}}{.002} = 667 \Omega$$

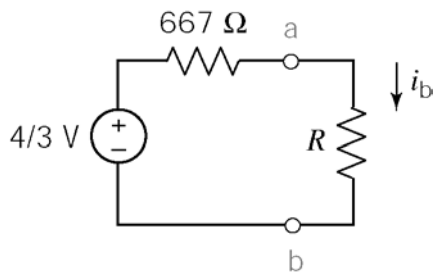

$$i_b = \frac{\frac{4}{3}}{667 + R}$$

$i_b = 0.002 \text{ A}$ requires

$$R = \frac{\frac{4}{3}}{0.002} - 667 = 0$$

(checked using LNAP 8/15/02)

P5.5-12

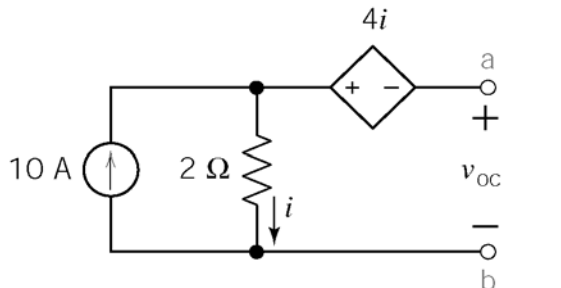

$$10 = i + 0 \Rightarrow i = 10 \text{ A}$$

$$v_{oc} + 4i - 2i = 0$$

$$\Rightarrow v_{oc} = -2i = \underline{-20 \text{ V}}$$

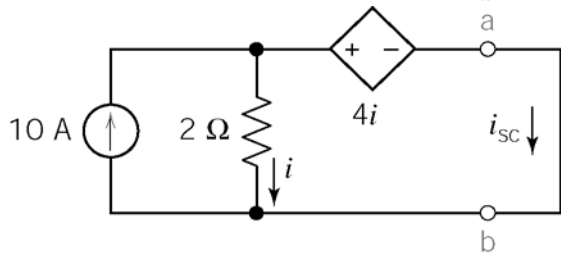

$$i + i_{sc} = 10 \Rightarrow i = 10 - i_{sc}$$

$$4i + 0 - 2i = 0 \Rightarrow i = 0 \Rightarrow i_{sc} = 10 \text{ A}$$

$$R_t = \frac{v_{oc}}{i_{sc}} = \frac{-20}{10} = -2 \Omega$$

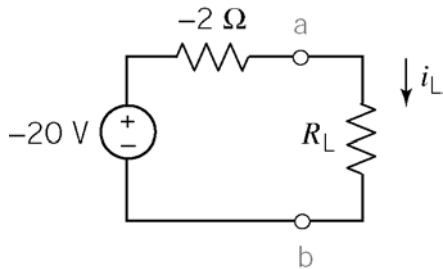

$$-2 = i_L = \frac{-20}{R_L - 2} \Rightarrow R_L = 12 \Omega$$

(checked using LNAP 8/15/02)

Section 5-6: Norton's Theorem

P5.6-1

When the terminals of the boxes are open-circuited, no current flows in Box A, but the resistor in Box B dissipates 1 watt. Box B is therefore warmer than Box A. If you short the terminals of each box, the resistor in Box A will draw 1 amp and dissipate 1 watt. The resistor in Box B will be shorted, draw no current, and dissipate no power. Then Box A will warm up and Box B will cool off.

P5.6-2

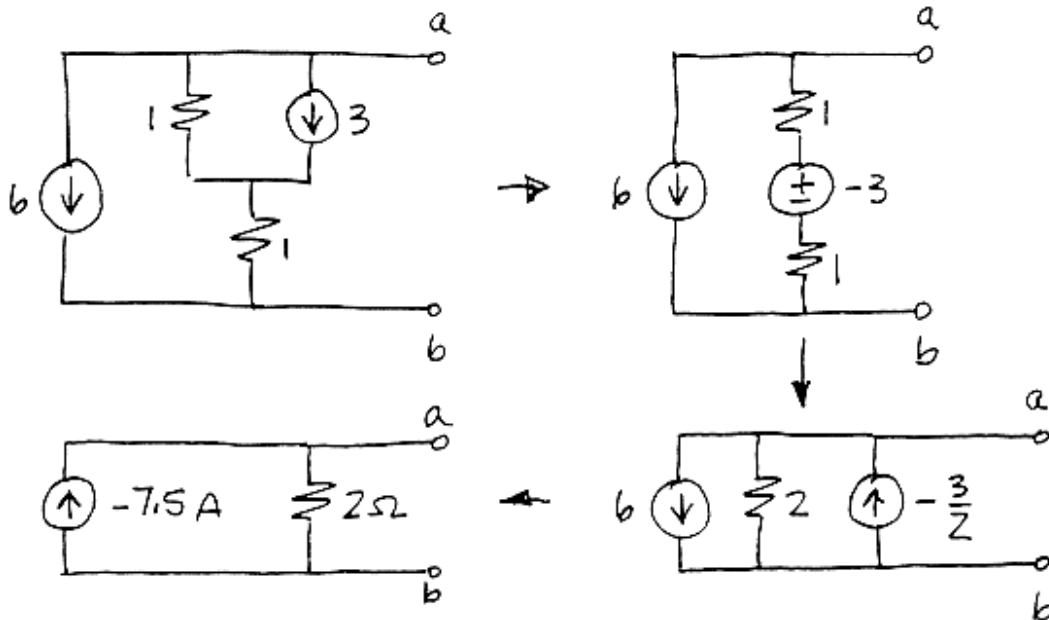

(checked using LNAP 8/16/02)

P5.6-3

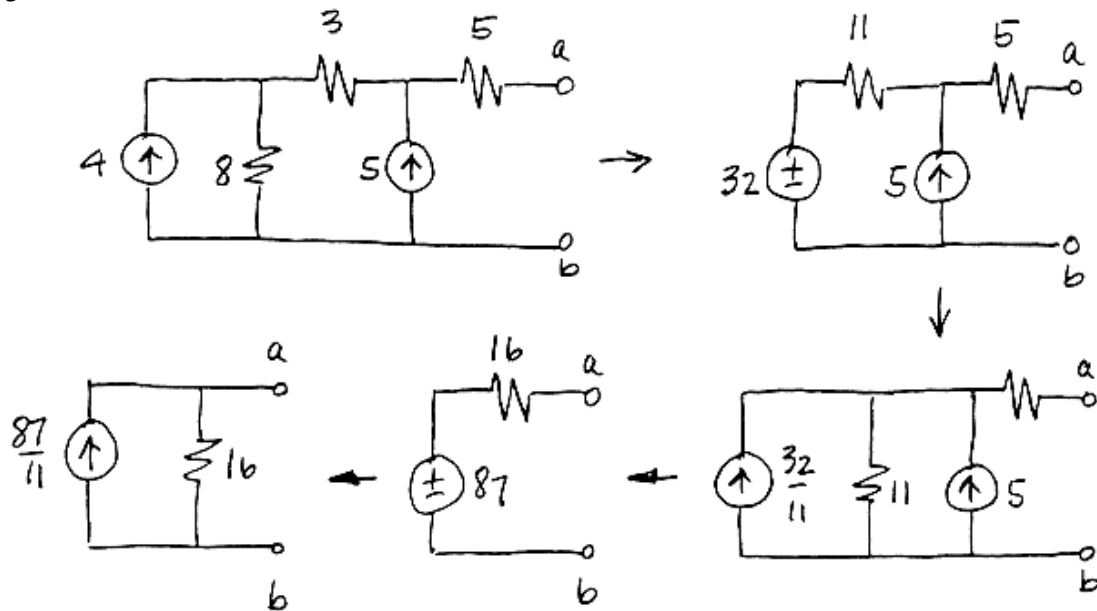

P5.6-4

To determine the value of the short circuit current, i_{sc} , we connect a short circuit across the terminals of the circuit and then calculate the value of the current in that short circuit. Figure (a) shows the circuit from Figure 5.6-4a after adding the short circuit and labeling the short circuit current. Also, the meshes have been identified and labeled in anticipation of writing mesh equations. Let i_1 and i_2 denote the mesh currents in meshes 1 and 2, respectively.

In Figure (a), mesh current i_2 is equal to the current in the short circuit. Consequently, $i_2 = i_{sc}$. The controlling current of the CCVS is expressed in terms of the mesh currents as

$$i_a = i_1 - i_2 = i_1 - i_{sc}$$

Apply KVL to mesh 1 to get

$$3i_1 - 2(i_1 - i_2) + 6(i_1 - i_2) - 10 = 0 \Rightarrow 7i_1 - 4i_2 = 10 \quad (1)$$

Apply KVL to mesh 2 to get

$$5i_2 - 6(i_1 - i_2) = 0 \Rightarrow -6i_1 + 11i_2 = 0 \Rightarrow i_1 = \frac{11}{6}i_2$$

Substituting into equation 1 gives

$$7\left(\frac{11}{6}i_2\right) - 4i_2 = 10 \Rightarrow i_2 = 1.13 \text{ A} \Rightarrow i_{sc} = 1.13 \text{ A}$$

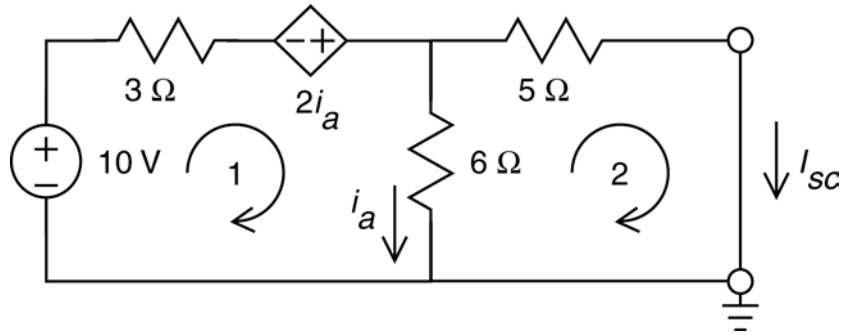

Figure (a) Calculating the short circuit current, i_{sc} , using mesh equations.

To determine the value of the Thevenin resistance, R_t , first replace the 10 V voltage source by a 0 V voltage source, i.e. a short circuit. Next, connect a current source across the terminals of the circuit and then label the voltage across that current source as shown in Figure (b). The Thevenin resistance will be calculated from the current and voltage of the current source as

$$R_t = \frac{v_T}{i_T}$$

In Figure (b), the meshes have been identified and labeled in anticipation of writing mesh equations. Let i_1 and i_2 denote the mesh currents in meshes 1 and 2, respectively.

In Figure (b), mesh current i_2 is equal to the negative of the current source current. Consequently, $i_2 = i_T$. The controlling current of the CCVS is expressed in terms of the mesh currents as

$$i_a = i_1 - i_2 = i_1 + i_T$$

Apply KVL to mesh 1 to get

$$3i_1 - 2(i_1 - i_2) + 6(i_1 - i_2) = 0 \Rightarrow 7i_1 - 4i_2 = 0 \Rightarrow i_1 = \frac{4}{7}i_2 \quad (2)$$

Apply KVL to mesh 2 to get

$$5i_2 + v_T - 6(i_1 - i_2) = 0 \Rightarrow -6i_1 + 11i_2 = -v_T$$

Substituting for i_1 using equation 2 gives

$$-6\left(\frac{4}{7}i_2\right) + 11i_2 = -v_T \Rightarrow 7.57i_2 = -v_T$$

Finally,

$$R_t = \frac{v_T}{i_T} = \frac{-v_T}{-i_T} = \frac{-v_T}{i_2} = 7.57 \Omega$$

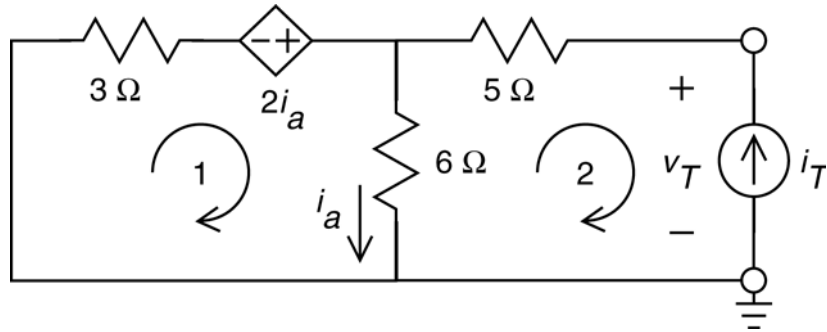

Figure (b) Calculating the Thevenin resistance, $R_t = \frac{v_T}{i_T}$, using mesh equations.

To determine the value of the open circuit voltage, v_{oc} , we connect an open circuit across the terminals of the circuit and then calculate the value of the voltage across that open circuit. Figure (c) shows the circuit from Figure 4.6-4a after adding the open circuit and labeling the open circuit voltage. Also, the meshes have been identified and labeled in anticipation of writing mesh equations. Let i_1 and i_2 denote the mesh currents in meshes 1 and 2, respectively.

In Figure (c), mesh current i_2 is equal to the current in the open circuit. Consequently, $i_2 = 0$ A. The controlling current of the CCVS is expressed in terms of the mesh currents as

$$i_a = i_1 - i_2 = i_1 - 0 = i_1$$

Apply KVL to mesh 1 to get

$$\begin{aligned} 3i_1 - 2(i_1 - i_2) + 6(i_1 - i_2) - 10 &= 0 \Rightarrow 3i_1 - 2(i_1 - 0) + 6(i_1 - 0) - 10 = 0 \\ &\Rightarrow i_1 = \frac{10}{7} = 1.43 \text{ A} \end{aligned}$$

Apply KVL to mesh 2 to get

$$5i_2 + v_{oc} - 6(i_1 - i_2) = 0 \Rightarrow v_{oc} = 6(i_1) = 6(1.43) = 8.58 \text{ V}$$

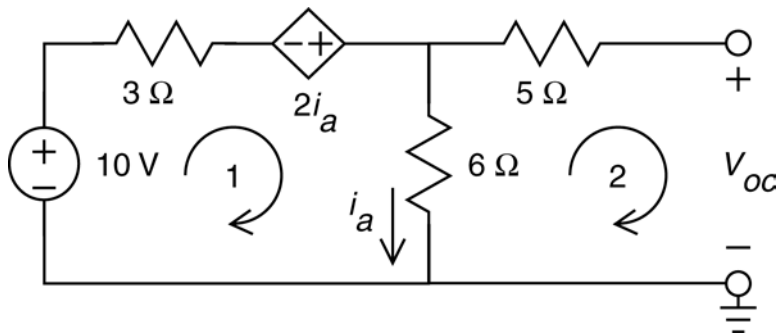

Figure (c) Calculating the open circuit voltage, v_{oc} , using mesh equations.

As a check, notice that $R_t i_{sc} = (7.57)(1.13) = 8.55 \approx v_{oc}$

(checked using LNAP 8/16/02)

P5.6-5

To determine the value of the short circuit current, I_{sc} , we connect a short circuit across the terminals of the circuit and then calculate the value of the current in that short circuit. Figure (a) shows the circuit from Figure 4.6-5a after adding the short circuit and labeling the short circuit current. Also, the nodes have been identified and labeled in anticipation of writing node equations. Let v_1 , v_2 and v_3 denote the node voltages at nodes 1, 2 and 3, respectively.

In Figure (a), node voltage v_1 is equal to the negative of the voltage source voltage. Consequently, $v_1 = -24 \text{ V}$. The voltage at node 3 is equal to the voltage across a short, $v_3 = 0$. The controlling voltage of the VCCS, v_a , is equal to the node voltage at node 2, i.e. $v_a = v_2$. The voltage at node 3 is equal to the voltage across a short, i.e. $v_3 = 0$.

Apply KCL at node 2 to get

$$\frac{v_1 - v_2}{3} = \frac{v_2 - v_3}{6} \Rightarrow 2v_1 + v_3 = 3v_2 \Rightarrow -48 = 3v_a \Rightarrow v_a = -16 \text{ V}$$

Apply KCL at node 3 to get

$$\frac{v_2 - v_3}{6} + \frac{4}{3}v_2 = i_{sc} \Rightarrow \frac{9}{6}v_a = i_{sc} \Rightarrow i_{sc} = \frac{9}{6}(-16) = -24 \text{ A}$$

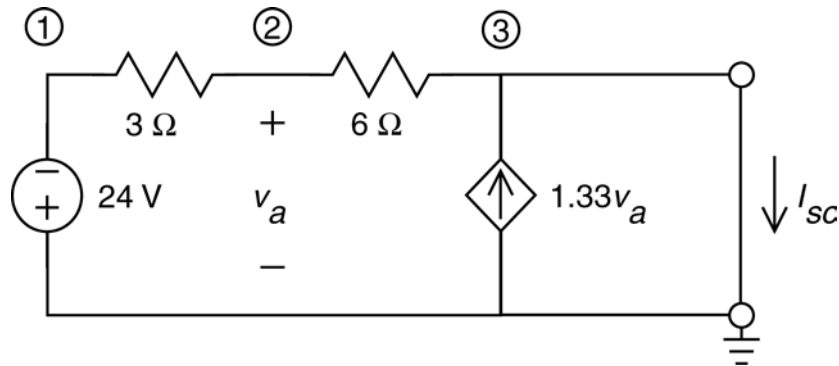

Figure (a) Calculating the short circuit current, I_{sc} , using mesh equations.

To determine the value of the Thevenin resistance, R_{th} , first replace the 24 V voltage source by a 0 V voltage source, i.e. a short circuit. Next, connect a current source circuit across the terminals of the circuit and then label the voltage across that current source as shown in Figure (b). The Thevenin resistance will be calculated from the current and voltage of the current source as

$$R_{th} = \frac{v_T}{i_T}$$

Also, the nodes have been identified and labeled in anticipation of writing node equations. Let v_1 , v_2 and v_3 denote the node voltages at nodes 1, 2 and 3, respectively.

In Figure (b), node voltage v_1 is equal to the across a short circuit, i.e. $v_1 = 0$. The controlling voltage of the VCCS, v_a , is equal to the node voltage at node 2, i.e. $v_a = v_2$. The voltage at node 3 is equal to the voltage across the current source, i.e. $v_3 = v_T$.

Apply KCL at node 2 to get

$$\frac{v_1 - v_2}{3} = \frac{v_2 - v_3}{6} \Rightarrow 2v_1 + v_3 = 3v_2 \Rightarrow v_T = 3v_a$$

Apply KCL at node 3 to get

$$\begin{aligned} \frac{v_2 - v_3}{6} + \frac{4}{3}v_2 + i_T &= 0 \Rightarrow 9v_2 - v_3 + 6i_T = 0 \\ &\Rightarrow 9v_a - v_T + 6i_T = 0 \\ &\Rightarrow 3v_T - v_T + 6i_T = 0 \Rightarrow 2v_T = -6i_T \end{aligned}$$

Finally,

$$R_t = \frac{v_T}{i_T} = -3 \Omega$$

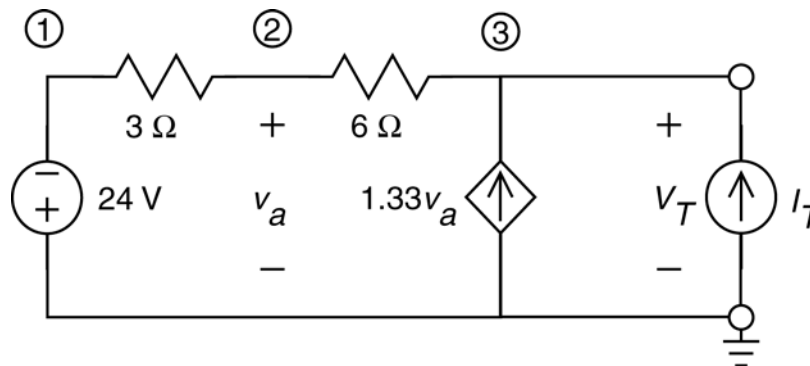

Figure (b) Calculating the Thevenin resistance, $R_{th} = \frac{v_T}{i_T}$, using mesh equations.

To determine the value of the open circuit voltage, v_{oc} , we connect an open circuit across the terminals of the circuit and then calculate the value of the voltage across that open circuit. Figure (c) shows the circuit from Figure P 4.6-5a after adding the open circuit and labeling the open circuit voltage. Also, the nodes have been identified and labeled in anticipation of writing node equations. Let v_1 , v_2 and v_3 denote the node voltages at nodes 1, 2 and 3, respectively.

In Figure (c), node voltage v_1 is equal to the negative of the voltage source voltage. Consequently, $v_1 = -24$ V. The controlling voltage of the VCCS, v_a , is equal to the node voltage at node 2, i.e. $v_a = v_2$. The voltage at node 3 is equal to the open circuit voltage, i.e. $v_3 = v_{oc}$.

Apply KCL at node 2 to get

$$\frac{v_1 - v_2}{3} = \frac{v_2 - v_3}{6} \Rightarrow 2v_1 + v_3 = 3v_2 \Rightarrow -48 + v_{oc} = 3v_a$$

Apply KCL at node 3 to get

$$\frac{v_2 - v_3}{6} + \frac{4}{3}v_2 = 0 \Rightarrow 9v_2 - v_3 = 0 \Rightarrow 9v_a = v_{oc}$$

Combining these equations gives

$$3(-48 + v_{oc}) = 9v_a = v_{oc} \Rightarrow v_{oc} = 72 \text{ V}$$

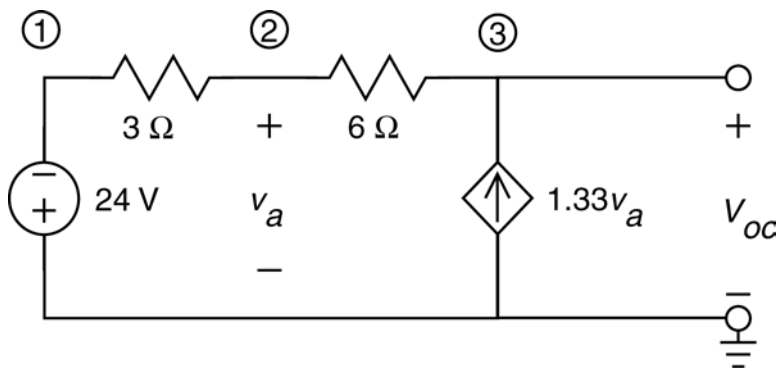

Figure (c) Calculating the open circuit voltage, v_{oc} , using node equations.

As a check, notice that

$$R_{th} I_{sc} = (-3)(-24) = 72 = V_{oc}$$

(checked using LNAP 8/16/02)

Section 5-7: Maximum Power Transfer

P5.7-1

a) For maximum power transfer, set R_L equal to the Thevenin resistance:

$$R_L = R_t = 100 + 1 = 101 \Omega$$

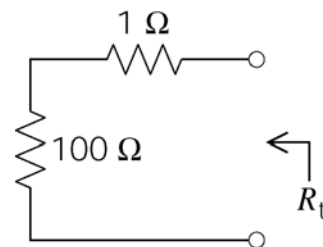

b) To calculate the maximum power, first replace the circuit connected to R_L by its Thevenin equivalent circuit:

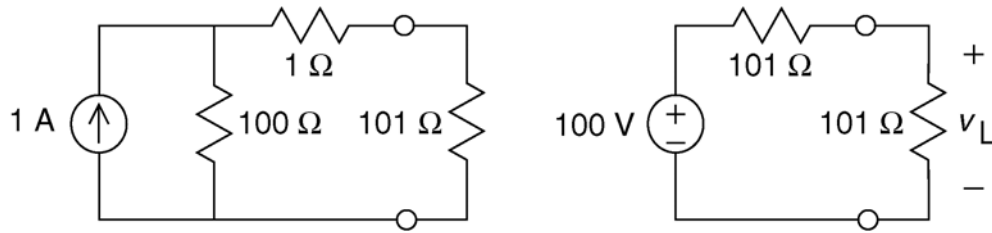

The voltage across R_L is
$$v_L = \frac{101}{101+101}(100) = 50 \text{ V}$$

Then
$$p_{\max} = \frac{v_L^2}{R_L} = \frac{50^2}{101} = 24.75 \text{ W}$$

P5.7-2

Reduce the circuit using source transformations:

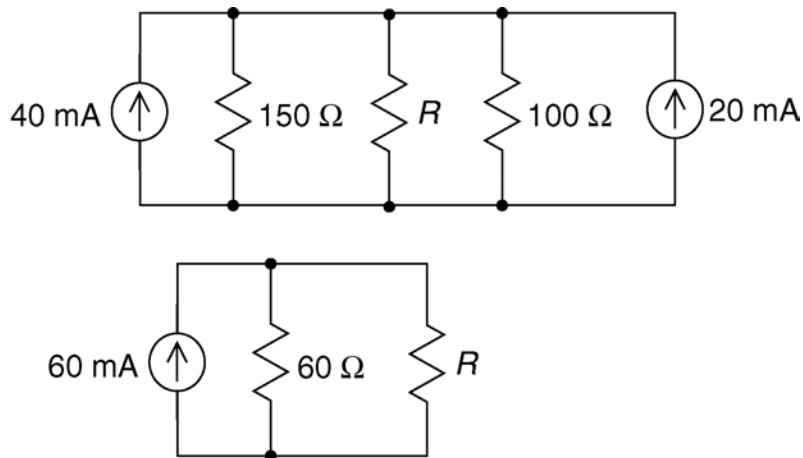

Then (a) maximum power will be dissipated in resistor R when: $R = R_t = 60 \Omega$ and (b) the value of that maximum power is

$$P_{\max} = i_R^2(R) = (0.03)^2(60) = \underline{54 \text{ mW}}$$

P5.7-3

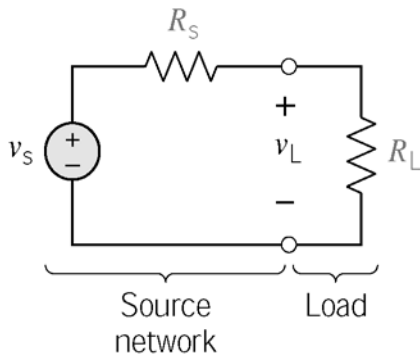

$$v_L = v_s \left[\frac{R_L}{R_s + R_L} \right]$$

$$\therefore p_L = \frac{v_L^2}{R_L} = \frac{v_s^2 R_L}{(R_s + R_L)^2}$$

By inspection, p_L is max when you reduce R_s to get the smallest denominator.

\therefore set $R_s = 0$

P5.7-4

Find R_t by finding i_{sc} and v_{oc} :

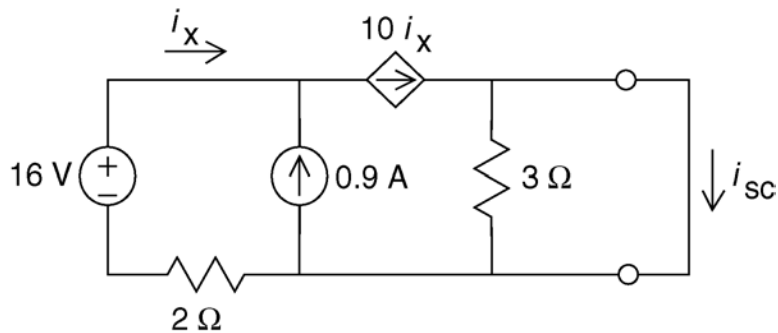

The current in the 3 Ω resistor is zero because of the short circuit. Consequently, $i_{sc} = 10 i_x$. Apply KCL at the top-left node to get

$$i_x + 0.9 = 10 i_x \Rightarrow i_x = \frac{0.9}{9} = 0.1 \text{ A}$$

so

$$i_{sc} = 10 i_x = 1 \text{ A}$$

Next

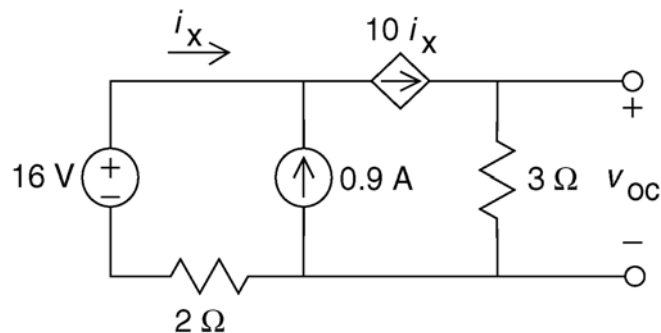

Apply KCL at the top-left node to get

$$i_x + 0.9 = 10 i_x \Rightarrow i_x = \frac{0.9}{9} = 0.1 \text{ A}$$

Apply Ohm's law to the 3Ω resistor to get

$$v_{oc} = 3(10 i_x) = 30(0.1) = 3 \text{ V}$$

For maximum power transfer to R_L :

$$R_L = R_t = \frac{v_{oc}}{i_{sc}} = \frac{3}{1} = 3 \Omega$$

The maximum power delivered to R_L is given by

$$p_{\max} = \frac{v_{oc}^2}{4 R_t} = \frac{3^2}{4(3)} = \frac{3}{4} \text{ W}$$

P5.7-5

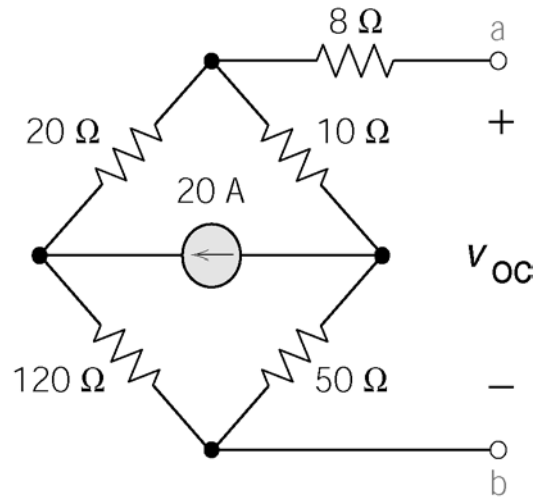
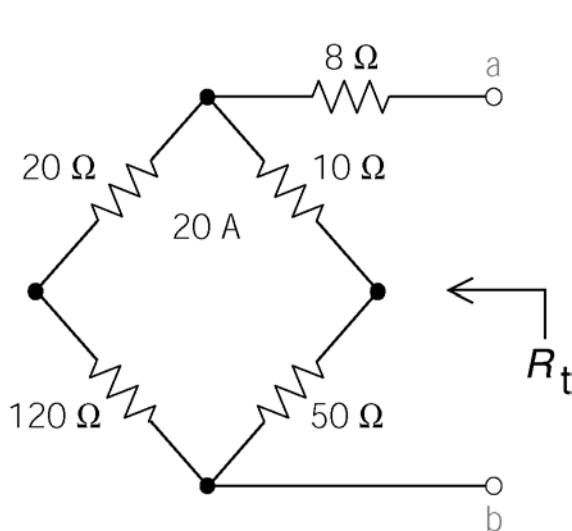

The required value of R is

$$R = R_t = 8 + \frac{(20+120)(10+50)}{(20+120)+(10+50)} = 50 \Omega$$

$$\begin{aligned} v_{oc} &= \left[\frac{170}{170+30}(20) \right] 10 - \left[\frac{30}{170+30}(20) \right] 50 \\ &= \frac{170(20)(10) - 30(20)(50)}{200} = \frac{4000}{200} = 20 \text{ V} \end{aligned}$$

The maximum power is given by

$$p_{\max} = \frac{v_{oc}^2}{4 R_t} = \frac{20^2}{4(50)} = 2 \text{ W}$$

PSpice Problems

SP5-1

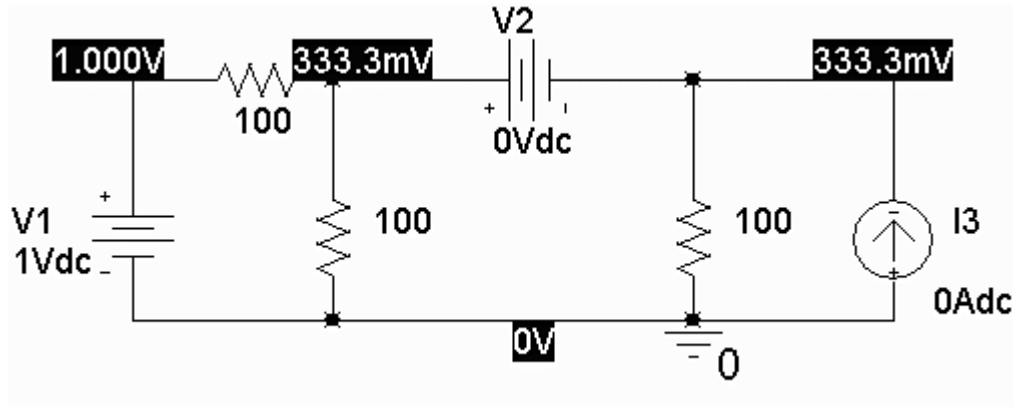

$$a = 0.3333$$

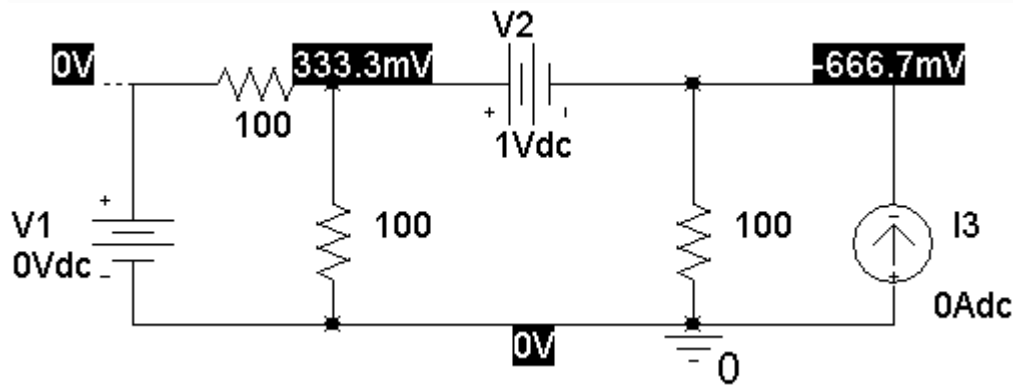

$$b = 0.3333$$

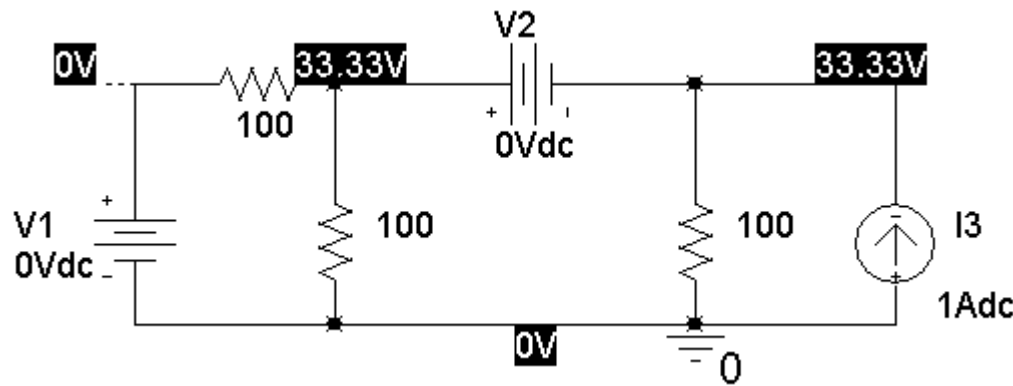

$$c = 33.33 \text{ V/A}$$

(a)
$$v_o = 0.3333 v_1 + 0.3333 v_2 + 33.33 i_3$$

(b)
$$7 = 0.3333(10) + 0.3333(8) + 33.33 i_3 \Rightarrow i_3 = \frac{7 - \frac{18}{3}}{\frac{100}{3}} = \frac{3}{100} = 30 \text{ mA}$$

SP5-2

Before the source transformation:

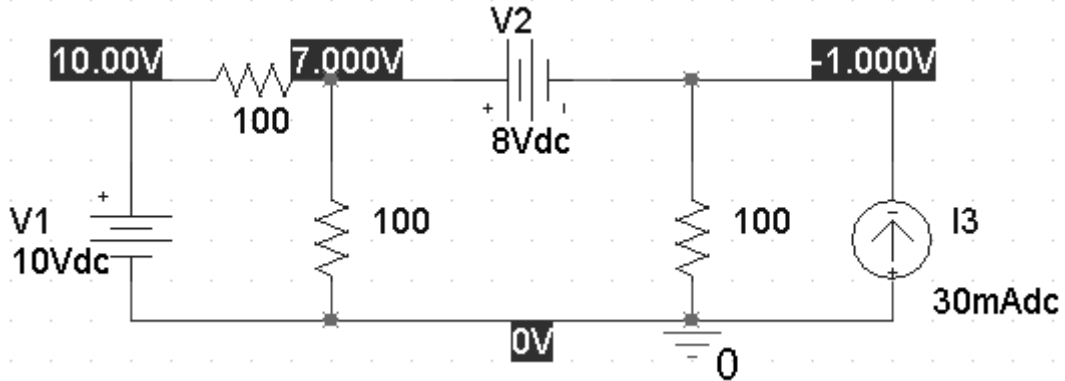

VOLTAGE SOURCE CURRENTS

NAME	CURRENT
V_V1	-3.000E-02
V_V2	-4.000E-02

After the source transformation:

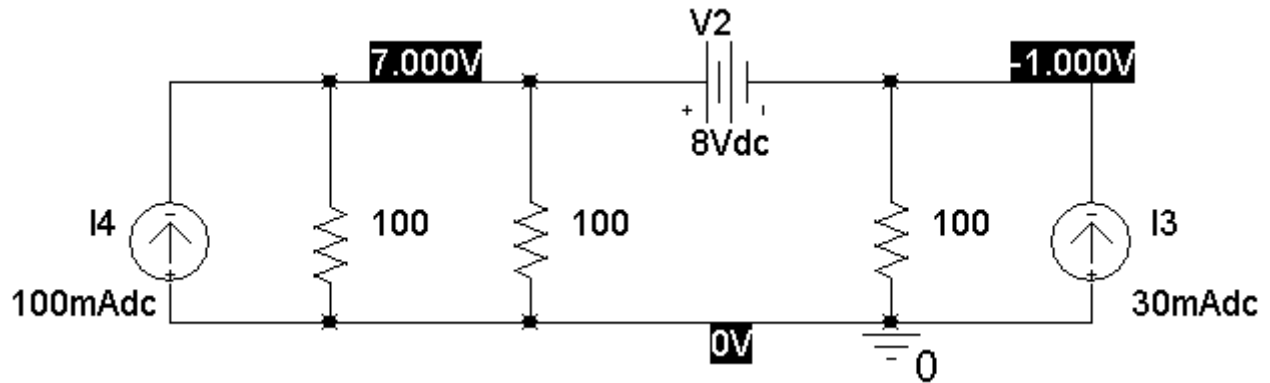

VOLTAGE SOURCE CURRENTS

NAME	CURRENT
V_V2	-4.000E-02

SP5-3

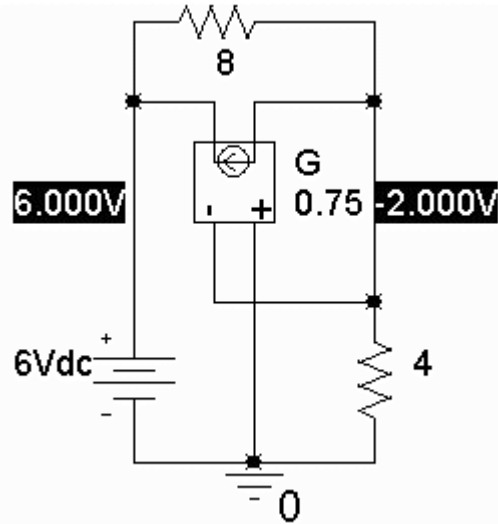

$$v_{oc} = -2 \text{ V}$$

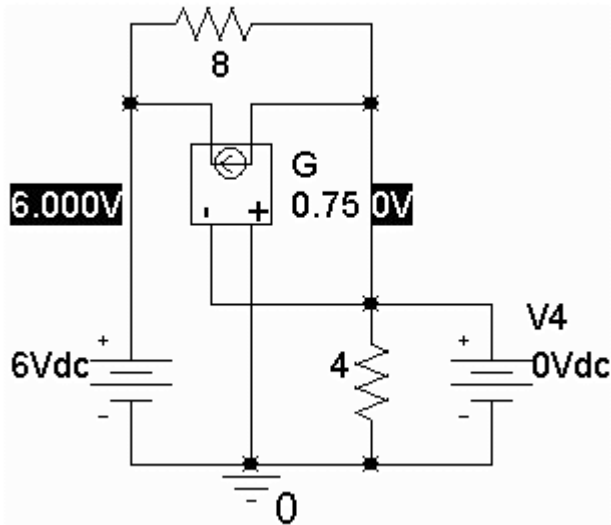

VOLTAGE SOURCE CURRENTS

NAME	CURRENT
V_V3	-7.500E-01
V_V4	7.500E-01

$$i_{sc} = 0.75 \text{ A}$$

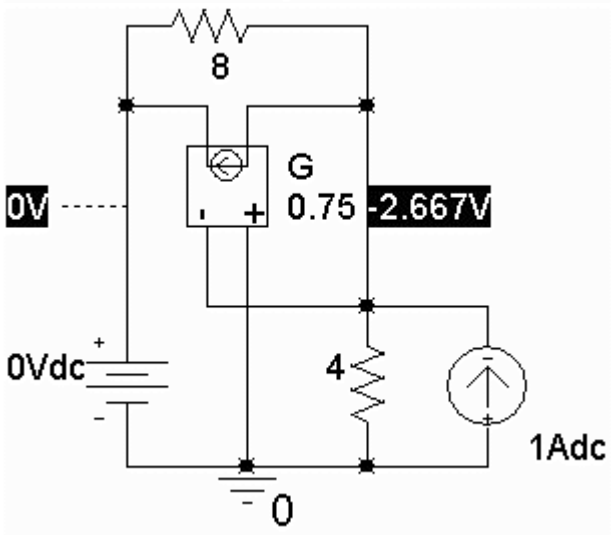

$$R_t = -2.66 \Omega$$

SP5-4

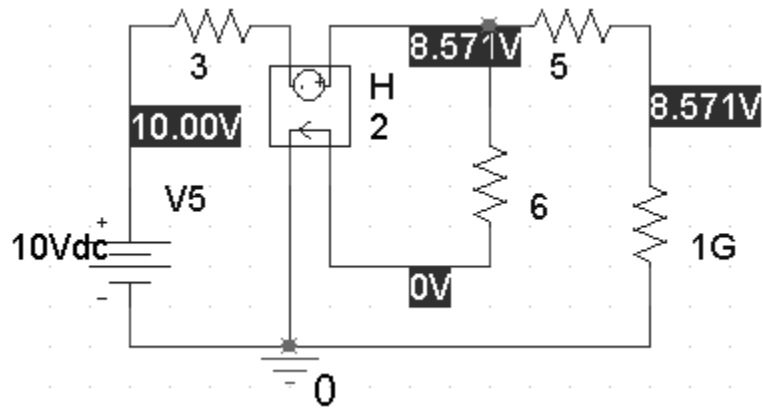

$$v_{oc} = 8.571 \text{ V}$$

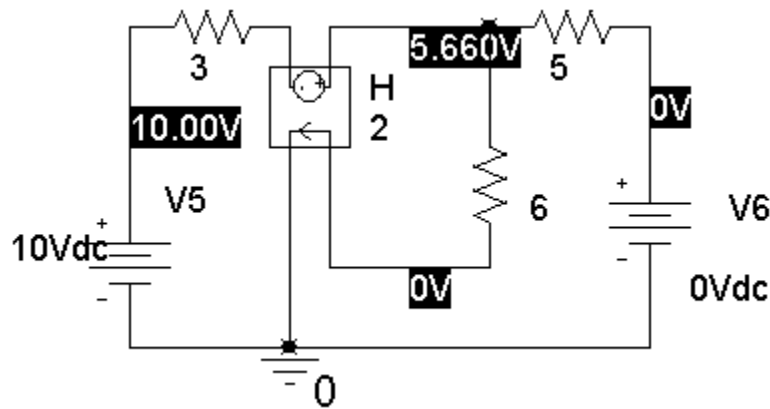

VOLTAGE SOURCE CURRENTS

NAME	CURRENT
V_V5	-2.075E+00
V_V6	1.132E+00
X_H1.VH_H1	9.434E-01

$$i_{sc} = 1.132 \text{ A}$$

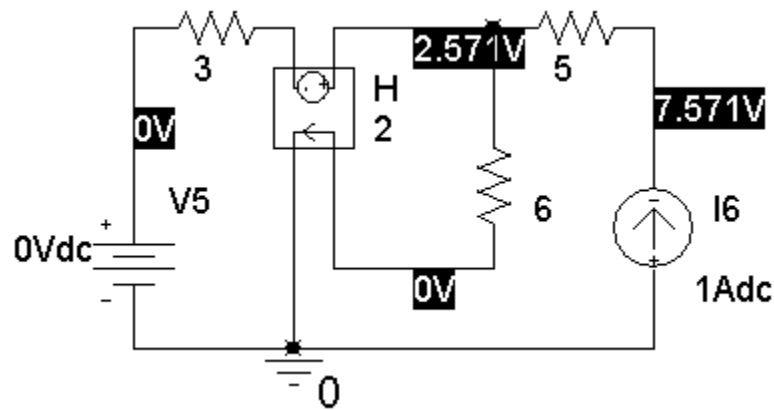

$$R_t = 7.571 \Omega$$

Verification Problems

VP5-1

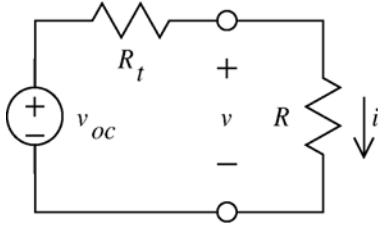

Use the data in the first two lines of the table to determine v_{oc} and R_t :

$$\left. \begin{aligned} 0.0972 &= \frac{v_{oc}}{R_t + 0} \\ 0.0438 &= \frac{v_{oc}}{R_t + 500} \end{aligned} \right\} \Rightarrow \begin{cases} v_{oc} = 39.9 \text{ V} \\ R_t = 410 \text{ } \Omega \end{cases}$$

Now check the third line of the table. When $R = 5000 \text{ } \Omega$:

$$i = \frac{v_{oc}}{R_t + R} = \frac{39.9}{410 + 5000} = 7.37 \text{ mA}$$

which disagree with the data in the table.

The data is not consistent.

VP5-2

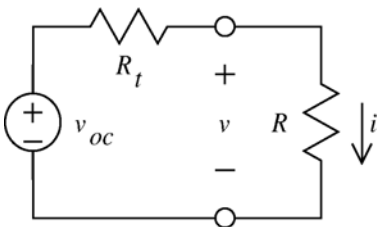

Use the data in the table to determine v_{oc} and i_{sc} :

$$v_{oc} = 12 \text{ V} \quad (\text{line 1 of the table})$$

$$i_{sc} = 3 \text{ mA} \quad (\text{line 3 of the table})$$

$$\text{so } R_t = \frac{v_{oc}}{i_{sc}} = 4 \text{ k}\Omega$$

Next, check line 2 of the table. When $R = 10 \text{ k}\Omega$:

$$i = \frac{v_{oc}}{R_t + R} = \frac{12}{10(10^3) + 4(10^3)} = 0.857 \text{ mA}$$

which agrees with the data in the table.

$$\text{To cause } i = 1 \text{ mA requires } 0.001 = i = \frac{v_{oc}}{R_t + R} = \frac{12}{10(10^3) + R} \Rightarrow R = 8000 \text{ } \Omega$$

I agree with my lab partner's claim that $R = 8000$ causes $i = 1 \text{ mA}$.

VP5-3

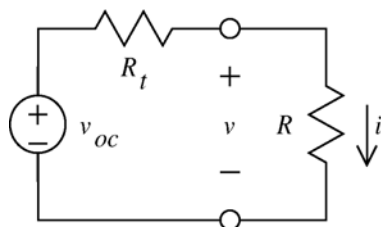

$$i = \frac{v_{oc}}{R_t + R} = \frac{\frac{60}{11}}{\frac{6}{11}(110) + 40} = \frac{\frac{60}{11}}{60 + 40} = 54.55 \text{ mA}$$

The measurement supports the prelab calculation.

Design Problems

DP5-1

The equation of representing the straight line in Figure DP 5-1b is $v = -R_t i + v_{oc}$. That is, the slope of the line is equal to -1 times the Thevenin resistance and the "v - intercept" is equal to the open circuit voltage. Therefore: $R_t = -\frac{0-5}{0.008-0} = 625 \Omega$ and $v_{oc} = 5 \text{ V}$.

Try $R_1 = R_2 = 1 \text{ k}\Omega$. ($R_1 \parallel R_2$ must be smaller than $R_t = 625 \Omega$.) Then

$$5 = \frac{R_2}{R_1 + R_2} v_s = \frac{1}{2} v_s \Rightarrow v_s = 10 \text{ V}$$

and

$$625 = R_3 + \frac{R_1 R_2}{R_1 + R_2} = R_3 + 500 \Rightarrow R_3 = 125 \Omega$$

Now v_s , R_1 , R_2 and R_3 have all been specified so the design is complete.

DP5-2

The equation of representing the straight line in Figure DP 5-2b is $v = -R_t i + v_{oc}$. That is, the slope of the line is equal to -1 times the Thevenin resistance and the "v - intercept" is equal to the open circuit voltage. Therefore: $R_t = -\frac{0-(-3)}{-0.006-0} = 500 \Omega$ and $v_{oc} = -3 \text{ V}$.

From the circuit we calculate

$$R_t = \frac{R_3(R_1 + R_2)}{R_1 + R_2 + R_3} \text{ and } v_{oc} = -\frac{R_1 R_3}{R_1 + R_2 + R_3} i_s$$

so

$$500 \Omega = \frac{R_3(R_1 + R_2)}{R_1 + R_2 + R_3} \text{ and } -3 \text{ V} = -\frac{R_1 R_3}{R_1 + R_2 + R_3} i_s$$

Try $R_3 = 1\text{k}\Omega$ and $R_1 + R_2 = 1\text{k}\Omega$. Then $R_t = 500\ \Omega$ and

$$-3 = -\frac{1000R_1}{2000}i_s = -\frac{R_1}{2}i_s \Rightarrow 6 = R_1 i_s$$

This equation can be satisfied by taking $R_1 = 600\ \Omega$ and $i_s = 10\ \text{mA}$. Finally, $R_2 = 1\ \text{k}\Omega - 400\ \Omega = 400\ \Omega$. Now i_s , R_1 , R_2 and R_3 have all been specified so the design is complete.

DP5-3

The slope of the graph is positive so the Thevenin resistance is negative. This would require

$$R_3 + \frac{R_1 R_2}{R_1 + R_2} < 0, \text{ which is not possible since } R_1, R_2 \text{ and } R_3 \text{ will all be non-negative.}$$

Is it not possible to specify values of v_s , R_1 , R_2 and R_3 that cause the current i and the voltage v in Figure DP 5-3a to satisfy the relationship described by the graph in Figure DP 5-3b.

DP5-4

The equation of representing the straight line in Figure DP 5-4b is $v = -R_t i + v_{oc}$. That is, the slope of the line is equal to the Thevenin impedance and the "v - intercept" is equal to the open circuit voltage. Therefore: $R_t = -\frac{-5-0}{0-0.008} = -625\ \Omega$ and $v_{oc} = -5\ \text{V}$.

The open circuit voltage, v_{oc} , the short circuit current, i_{sc} , and the Thevenin resistance, R_t , of this circuit are given by

$$v_{oc} = \frac{R_2(d+1)}{R_1 + (d+1)R_2} v_s,$$

$$i_{sc} = \frac{(d+1)}{R_1} v_s$$

and

$$R_t = \frac{R_1 R_2}{R_1 + (d+1)R_2}$$

Let $R_1 = R_2 = 1\ \text{k}\Omega$. Then

$$-625\ \Omega = R_t = \frac{1000}{d+2} \Rightarrow d = \frac{1000}{-625} - 2 = -3.6\ \text{A/A}$$

and

$$-5 = \frac{(d+1)v_s}{d+2} \Rightarrow v_s = \frac{-3.6+2}{-3.6+1}(-5) = -3.077\ \text{V}$$

Now v_s , R_1 , R_2 and d have all been specified so the design is complete.

Chapter 6: The Operational Amplifier

Exercises

Ex. 6.4-1

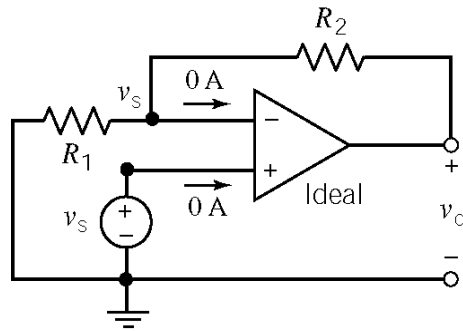

$$\frac{v_s}{R_1} + \frac{v_s - v_o}{R_2} + 0 = 0$$

$$\frac{v_o}{v_s} = 1 + \frac{R_2}{R_1}$$

Ex. 6.4-2

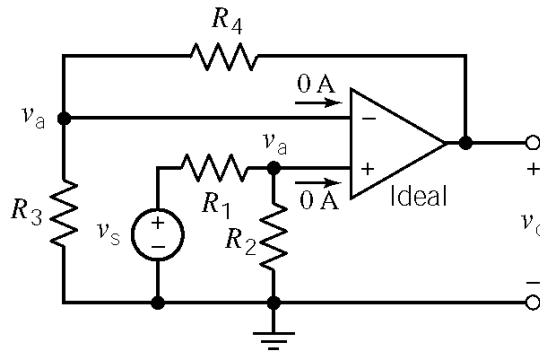

a)

$$v_a = \frac{R_2}{R_1 + R_2} v_s$$

$$\frac{v_a}{R_3} + \frac{v_a - v_o}{R_4} + 0 = 0$$

$$\frac{v_o}{v_a} = 1 + \frac{R_4}{R_3} \Rightarrow \frac{v_o}{v_s} = \left(\frac{R_2}{R_1 + R_2} \right) \left(1 + \frac{R_4}{R_3} \right)$$

b) When $R_2 \gg R_1$ then $\frac{R_2}{R_1 + R_2} \approx \frac{R_2}{R_2} = 1$ and $\frac{v_o}{v_s} \approx 1 + \frac{R_4}{R_3}$

Ex. 6.5-1

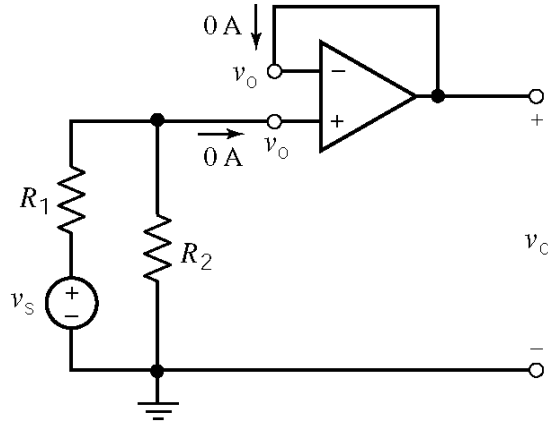

$$\frac{v_o}{R_2} + \frac{v_o - v_s}{R_1} + 0 = 0$$

$$\frac{v_o}{v_s} = \frac{R_2}{R_1 + R_2}$$

Ex. 6.6-1

$$\frac{v_{in} - v_{out}}{R_f} + \frac{v_{in}}{R_1} + 0 = 0 \Rightarrow v_{out} = \left(1 + \frac{R_f}{R_1}\right) v_{in}$$

when $R_f = 100 \text{ k}\Omega$ and $R_1 = 25 \text{ k}\Omega$ then

$$\frac{v_{out}}{v_{in}} = \left(1 + \frac{100 \cdot 10^3}{25 \cdot 10^3}\right) = 5$$

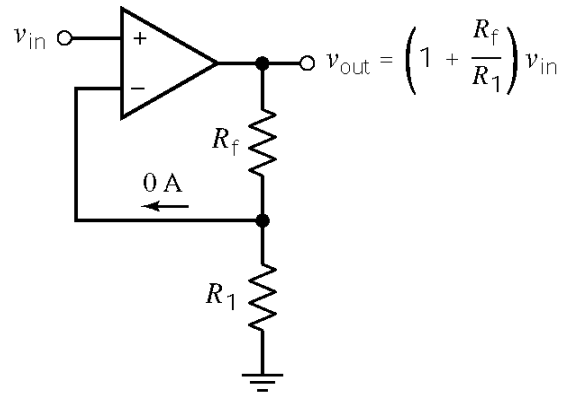

(b) Noninverting amplifier

Ex. 6.7-1

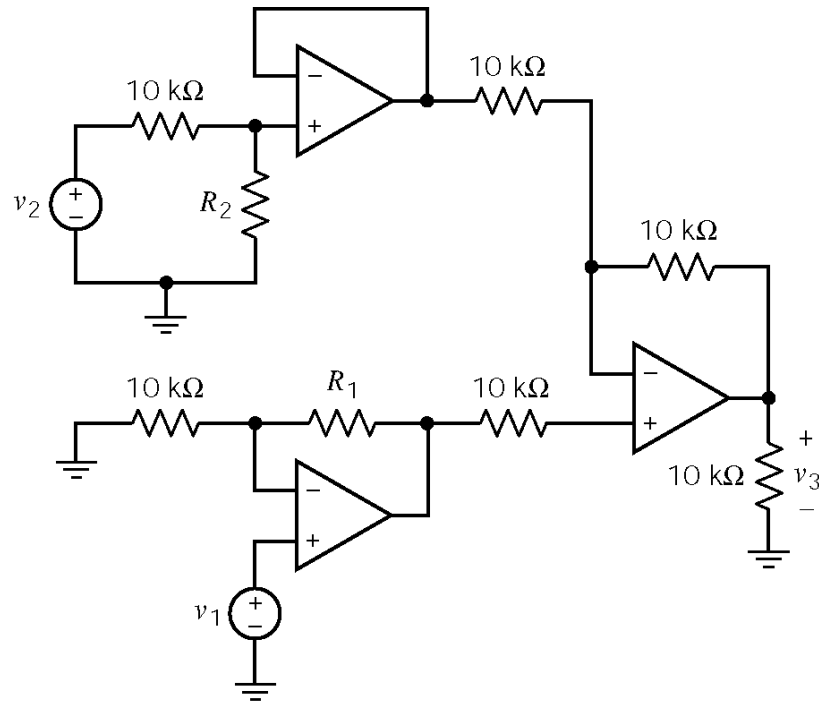

$$v_3 = \left(-\frac{10 \times 10^3}{10 \times 10^3} \right) \left(\frac{R_2}{R_2 + 10 \times 10^3} \right) v_2 + \left(1 + \frac{10 \times 10^3}{10 \times 10^3} \right) \left(1 + \frac{R_1}{10 \times 10^3} \right) v_1$$

$$= -\left(\frac{R_2}{R_2 + 10 \times 10^3} \right) v_2 + 2 \left(1 + \frac{R_1}{10 \times 10^3} \right) v_1$$

We require $v_3 = (4)v_1 - \left(\frac{1}{5}\right)v_2$, so

$$4 = 2 \left(1 + \frac{R_1}{10 \times 10^3} \right) \Rightarrow R_1 = 10 \times 10^3 = 10 \text{ k}\Omega$$

and

$$\frac{1}{5} = \frac{R_2}{R_2 + 10 \times 10^3} \Rightarrow R_2 + 10 \times 10^3 = 5 R_2 \Rightarrow R_2 = 2.5 \text{ k}\Omega$$

Ex. 6.7-2

As in Ex 6.7-1

$$v_3 = -\left(\frac{R_2}{R_2 + 10 \times 10^3}\right)v_2 + 2\left(1 + \frac{R_1}{10 \times 10^3}\right)v_1$$

We require $v_3 = (6)v_1 - \left(\frac{4}{5}\right)v_2$, so

$$6 = 2\left(1 + \frac{R_1}{10 \times 10^3}\right) \Rightarrow R_1 = 20 \times 10^3 = 20 \text{ k}\Omega$$

and

$$\frac{4}{5} = \frac{R_2}{R_2 + 10 \times 10^3} \Rightarrow 4R_2 + 40 \times 10^3 = 5R_2 \Rightarrow R_2 = 40 \text{ k}\Omega$$

Ex. 6.8-1

Analysis of the circuit in Section 6.7 showed that output offset voltage = $6 v_{os} + (50 \times 10^3) i_{b1}$

For a $\mu\text{A}741$ op amp, $|v_{os}| \leq 1 \text{ mV}$ and $|i_{b1}| \leq 80 \text{ nA}$ so

$$|\text{output offset voltage}| = |6 v_{os} + (50 \times 10^3) i_{b1}| \leq 6(10^{-3}) + (50 \times 10^3)(80 \times 10^{-9}) = 10 \text{ mV}$$

Ex. 6.8-2

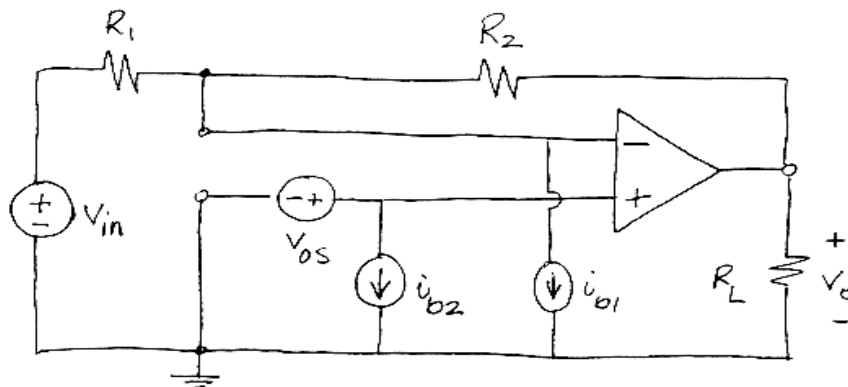

$$v_o = -\frac{R_2}{R_1} v_{in} + \left(1 + \frac{R_2}{R_1}\right) v_{os} + R_2 i_{b1}$$

When $R_2 = 10 \text{ k}\Omega$, $R_1 = 2 \text{ k}\Omega$, $|v_{os}| \leq 5 \text{ mV}$ and $|i_{b1}| \leq 500 \text{ nA}$ then

$$\text{output offset voltage} \leq 6(5 \times 10^{-3}) + (10 \times 10^3)(500 \cdot 10^{-9}) \leq 35 \times 10^{-3} = 35 \text{ mV}$$

Ex. 6.8-3

Analysis of this circuit in Section 6.7 showed that output offset voltage = $6 v_{os} + (50 \times 10^3) i_{b1}$

For a typical OPA101AM, $v_{os} = 0.1 \text{ mV}$ and $i_b = 0.012 \text{ nA}$ so

$$\begin{aligned} |\text{output offset voltage}| &\leq 6[0.1 \times 10^{-3}] + (50 \times 10^3)[0.012 \times 10^{-9}] \\ &\leq 0.6 \times 10^{-3} + 0.6 \times 10^{-6} \approx 0.6 \times 10^{-3} = 0.6 \text{ mV} \end{aligned}$$

Ex. 6.8-4

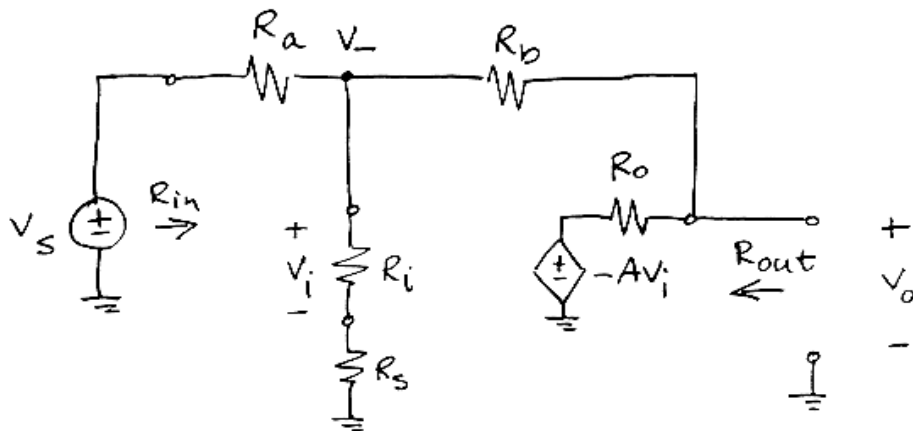

Writing node equations

$$\begin{aligned} \frac{v_- - v_s}{R_a} + \frac{v_- - v_o}{R_b} + \frac{v_-}{R_i + R_s} &= 0 \\ v_o - \left(-A \frac{R_i}{R_i + R_s} v_- \right) & \\ \frac{\quad}{R_o} + \frac{v_o - v_-}{R_b} &= 0 \end{aligned}$$

After some algebra

$$A_v = \frac{v_o}{v_s} = \frac{R_o (R_i + R_s) + A R_i R_f}{(R_f + R_o)(R_i + R_s) + R_a (R_f + R_o + R_i + R_s) - A R_i R_a}$$

For the given values, $A_v = -2.00006 \text{ V/V}$.

Problems

Section 6-4: The Ideal Operational Amplifier

P6.4-1

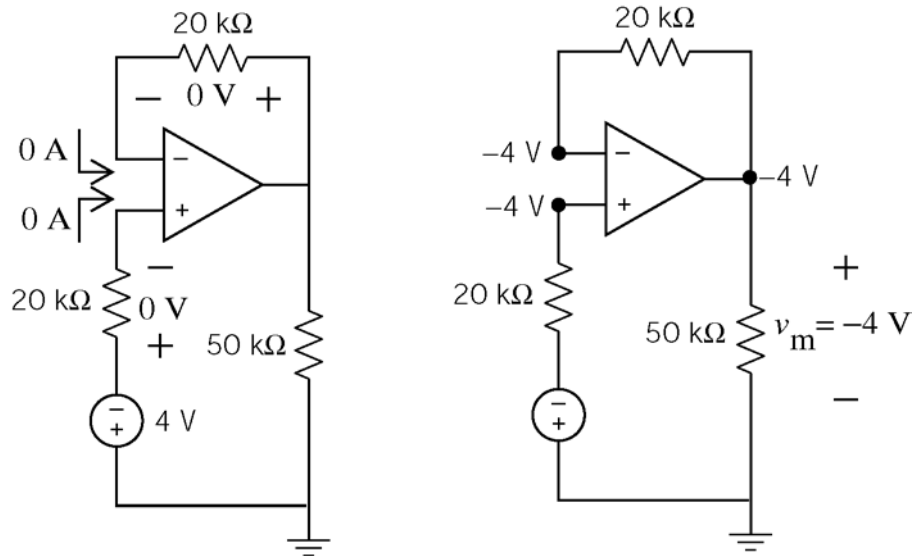

(checked using LNAP 8/16/02)

P6.4-2

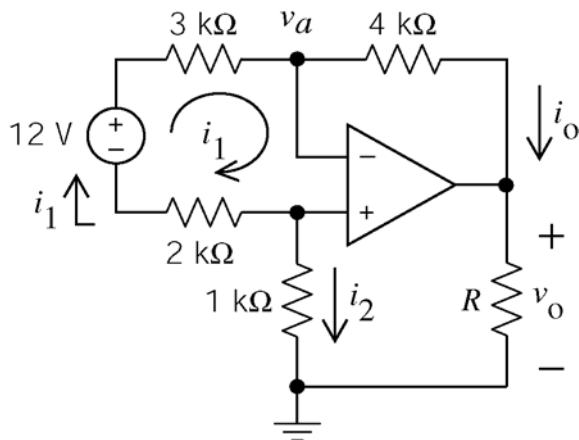

Apply KVL to loop 1:

$$-12 + 3000 i_1 + 0 + 2000 i_1 = 0$$

$$\Rightarrow i_1 = \frac{12}{5000} = 2.4 \text{ mA}$$

The currents into the inputs of an ideal op amp are zero so

$$i_o = i_1 = 2.4 \text{ mA}$$

$$i_2 = -i_1 = -2.4 \text{ mA}$$

$$v_a = i_2(1000) + 0 = -2.4 \text{ V}$$

Apply Ohm's law to the 4 kΩ resistor

$$v_o = v_a - i_o(4000)$$

$$= -2.4 - (2.4 \times 10^{-3})(4000) = -12 \text{ V}$$

(checked using LNAP 8/16/02)

P6.4-3

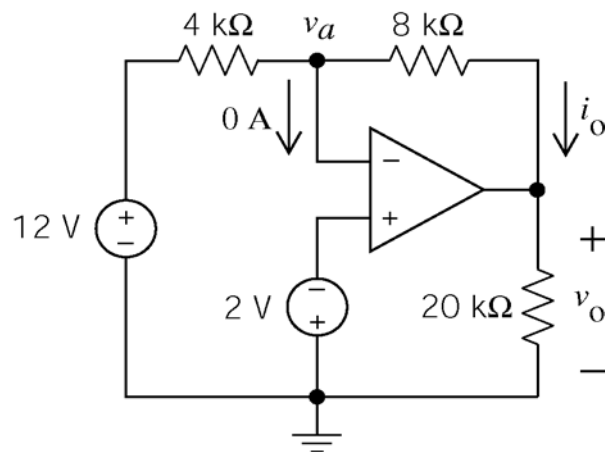

The voltages at the input nodes of an ideal op amp are equal so $v_a = -2 \text{ V}$.

Apply KCL at node a :

$$\frac{v_o - (-2)}{8000} + \frac{12 - (-2)}{4000} = 0 \Rightarrow v_o = -30 \text{ V}$$

Apply Ohm's law to the 8 kΩ resistor

$$i_o = \frac{-2 - v_o}{8000} = 3.5 \text{ mA}$$

(checked using LNAP 8/16/02)

P6.4-4

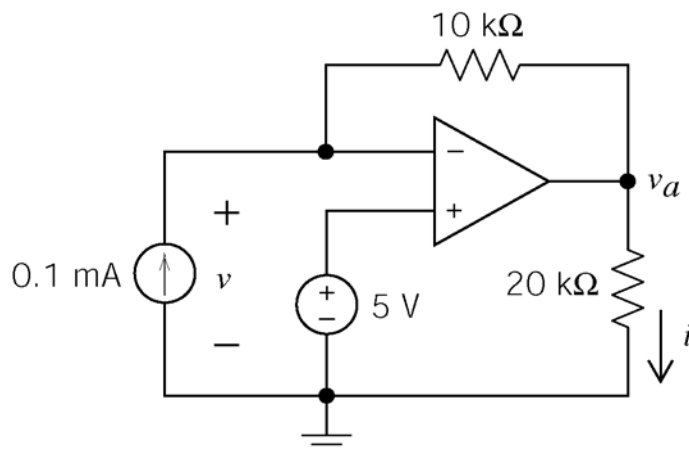

The voltages at the input nodes of an ideal op amp are equal so $v = 5 \text{ V}$.

Apply KCL at the inverting input node of the op amp:

$$-\left(\frac{v_a - 5}{10000}\right) - 0.1 \times 10^{-3} - 0 = 0 \Rightarrow v_a = 4 \text{ V}$$

Apply Ohm's law to the 20 kΩ resistor

$$i = \frac{v_a}{20000} = \frac{1}{5} \text{ mA}$$

(checked using LNAP 8/16/02)

P6.4-5

The voltages at the input nodes of an ideal op amp are equal so $v_a = 0 \text{ V}$. Apply KCL at node a :

$$-\left(\frac{v_o - 0}{3000}\right) - \left(\frac{12 - 0}{4000}\right) - 2 \cdot 10^{-3} = 0$$

$$\Rightarrow v_o = -15 \text{ V}$$

Apply KCL at the output node of the op amp:

$$i_o + \frac{v_o}{6000} + \frac{v_o}{3000} = 0 \Rightarrow i_o = 7.5 \text{ mA}$$

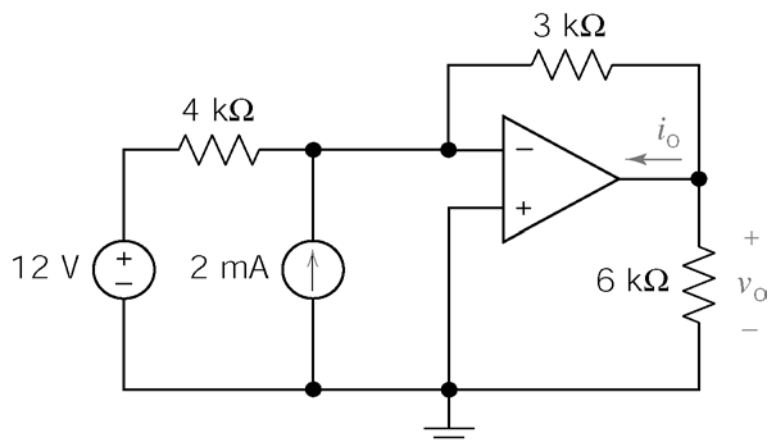

(checked using LNAP 8/16/02)

P6.4-6

The currents into the inputs of an ideal op amp are zero and the voltages at the input nodes of an ideal op amp are equal so $v_a = 2.5 \text{ V}$.

Apply Ohm's law to the $4 \text{ k}\Omega$ resistor:

$$i_a = \frac{v_a}{4000} = \frac{2.5}{4000} = 0.625 \text{ mA}$$

Apply KCL at node a :

$$i_b = i_a = 0.625 \text{ mA}$$

Apply KVL:

$$\begin{aligned} v_o &= 8000 i_b + 4000 i_a \\ &= (12 \times 10^3)(0.625 \times 10^{-3}) = 7.5 \text{ V} \end{aligned}$$

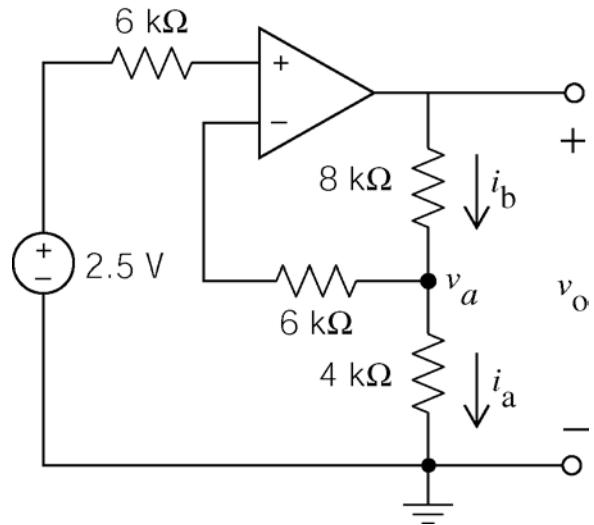

(checked using LNAP 8/16/02)

P6.4-7

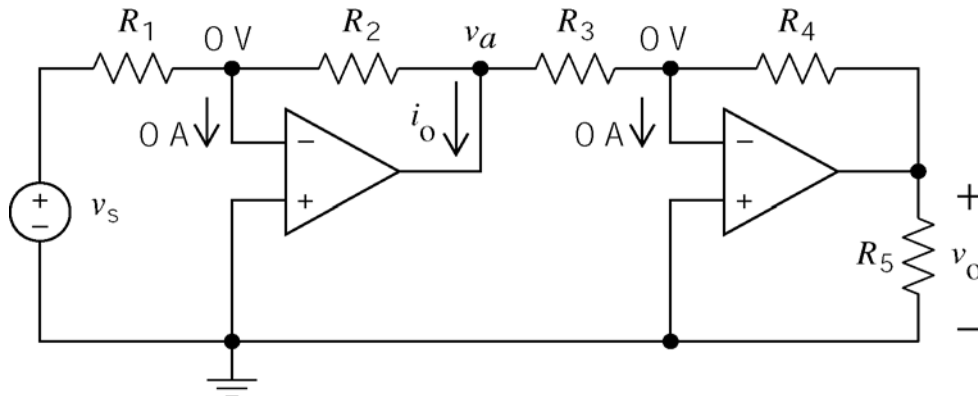

$$-\left(\frac{v_s - 0}{R_1}\right) - \left(\frac{v_a - 0}{R_2}\right) + 0 = 0 \Rightarrow v_a = -\frac{R_2}{R_1} v_s$$

$$i_o = \frac{0 - v_a}{R_2} + \frac{0 - v_a}{R_3} = -\frac{R_2 + R_3}{R_2 R_3} v_a = \left(\frac{R_2 + R_3}{R_1 R_3}\right) v_s$$

$$-\left(\frac{v_o - 0}{R_4}\right) - \left(\frac{v_a - 0}{R_3}\right) + 0 = 0 \Rightarrow v_o = -\frac{R_4}{R_3} v_a = \frac{R_2 R_4}{R_1 R_3} v_s$$

P6.4-8

The node voltages have been labeled using:

1. The currents into the inputs of an ideal op amp are zero and the voltages at the input nodes of an ideal op amp are equal.

2. KCL

3. Ohm's law

Then

$$v_o = 11.8 - 1.8 = 10 \text{ V}$$

and

$$i_o = \frac{10}{4000} = 2.5 \text{ mA}$$

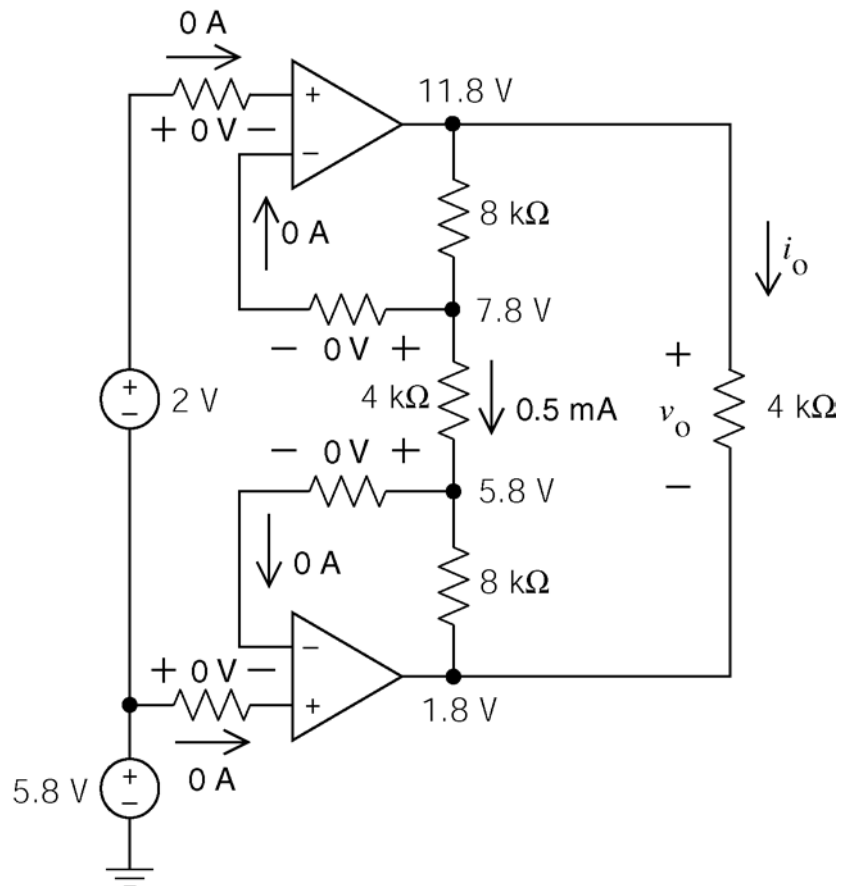

(checked using LNAP 8/16/02)

P6.4-9

KCL at node a:

$$\frac{v_a - (-18)}{4000} + \frac{v_a}{8000} + 0 = 0 \Rightarrow v_a = -12 \text{ V}$$

The node voltages at the input nodes of ideal op amps are equal so $v_b = v_a$.

Voltage division:

$$v_o = \frac{8000}{4000 + 8000} v_b = -8 \text{ V}$$

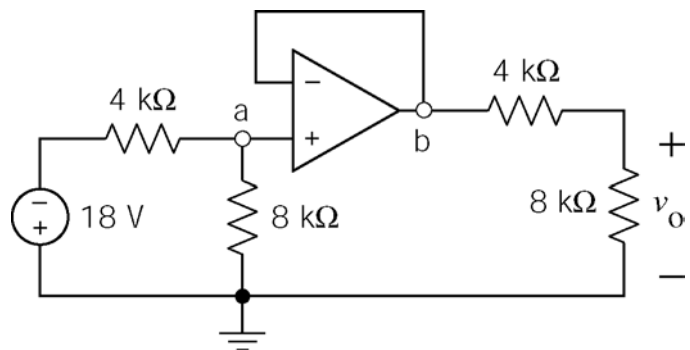

(check using LNAP 8/16/02)

Section 6-5: Nodal Analysis of Circuits Containing Ideal Operational Amplifiers

P6.5-1

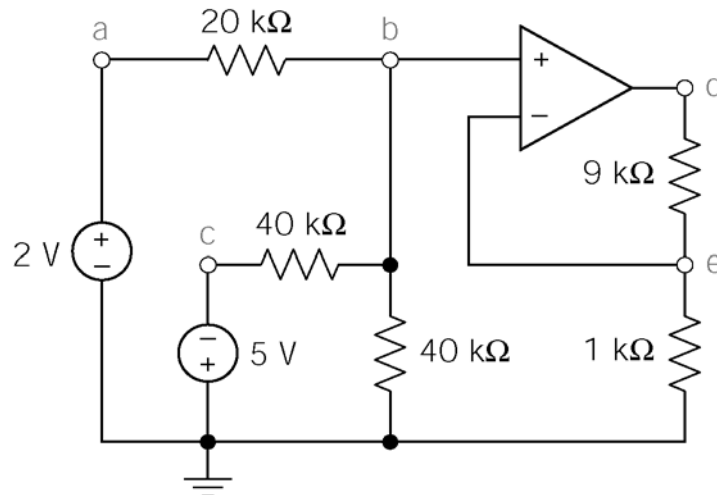

$$\text{KCL at node b: } \frac{v_b - 2}{20000} + \frac{v_b}{40000} + \frac{v_b + 5}{40000} = 0 \Rightarrow v_b = -\frac{1}{4} \text{ V}$$

The node voltages at the input nodes of an ideal op amp are equal so $v_e = v_b = -\frac{1}{4} \text{ V}$.

$$\text{KCL at node e: } \frac{v_e}{1000} + \frac{v_e - v_d}{9000} = 0 \Rightarrow v_d = 10v_e = -\frac{10}{4} \text{ V}$$

(checked using LNAP 8/16/02)

P6.5-2

Apply KCL at node a:

$$0 = \frac{v_a - 12}{6000} + \frac{v_a}{6000} + \frac{v_a - 0}{6000} \Rightarrow v_a = 4 \text{ V}$$

Apply KCL at the inverting input of the op amp:

$$-\left(\frac{v_a - 0}{6000}\right) + 0 + \left(\frac{0 - v_o}{6000}\right) = 0$$

$$\Rightarrow v_o = -v_a = -4 \text{ V}$$

Apply KCL at the output of the op amp:

$$i_o - \left(\frac{0 - v_o}{6000}\right) + \frac{v_o}{6000} = 0$$

$$\Rightarrow i_o = -\frac{v_o}{3000} = 1.33 \text{ mA}$$

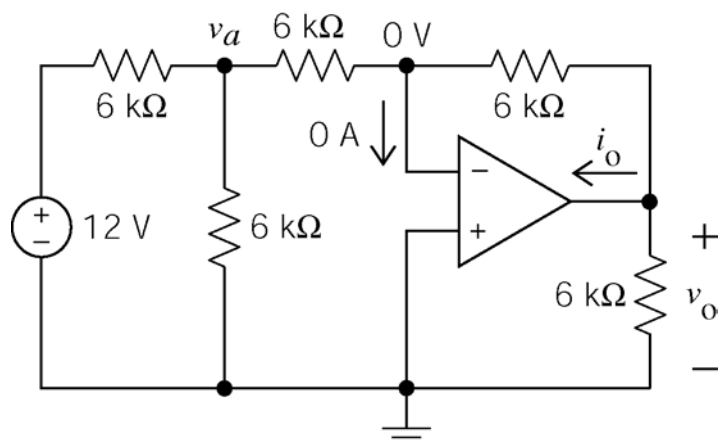

(checked using LNAP 8/16/02)

P6.5-3

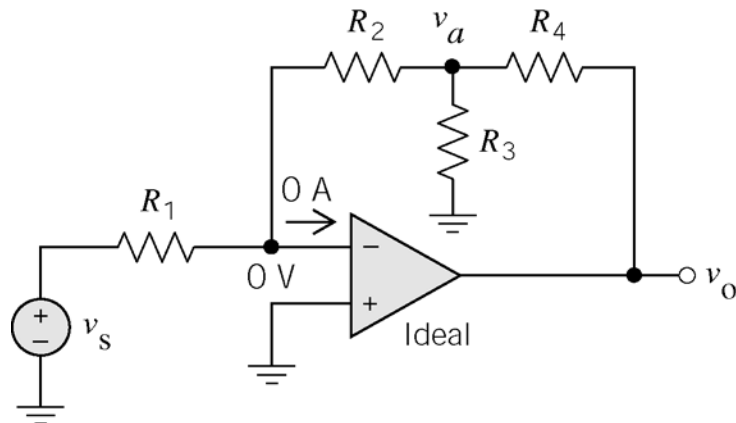

Apply KCL at the inverting input of the op amp:

$$-\left(\frac{v_a - 0}{R_2}\right) - \left(\frac{v_s - 0}{R_1}\right) = 0$$

$$\Rightarrow v_a = -\frac{R_2}{R_1} v_s$$

Apply KCL at node a:

$$\frac{v_a - v_o}{R_4} + \frac{v_a}{R_3} + \frac{v_a - 0}{R_2} = 0 \Rightarrow v_o = R_4 \left(\frac{1}{R_4} + \frac{1}{R_3} + \frac{1}{R_2} \right) v_a = \frac{R_2 R_3 + R_2 R_4 + R_3 R_4}{R_2 R_3} v_a$$

$$= -\frac{R_2 R_3 + R_2 R_4 + R_3 R_4}{R_1 R_3} v_s$$

Plug in values \Rightarrow yields $\frac{v_o}{v_s} = -\frac{30+900+30}{4.8} = -200 \text{ V/V}$

P6.5-4

Ohm's law:

$$i = \frac{v_1 - v_2}{R_2}$$

KVL:

$$v_o = (R_1 + R_2 + R_3) i = \frac{R_1 + R_2 + R_3}{R_2} (v_1 - v_2)$$

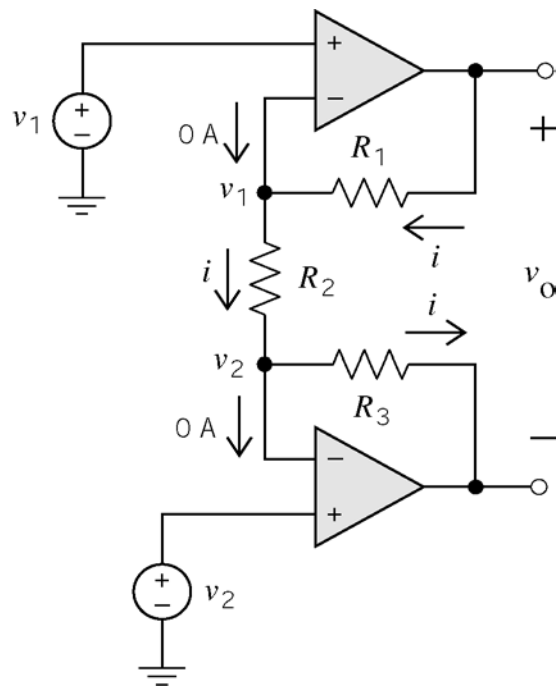

P6.5-5

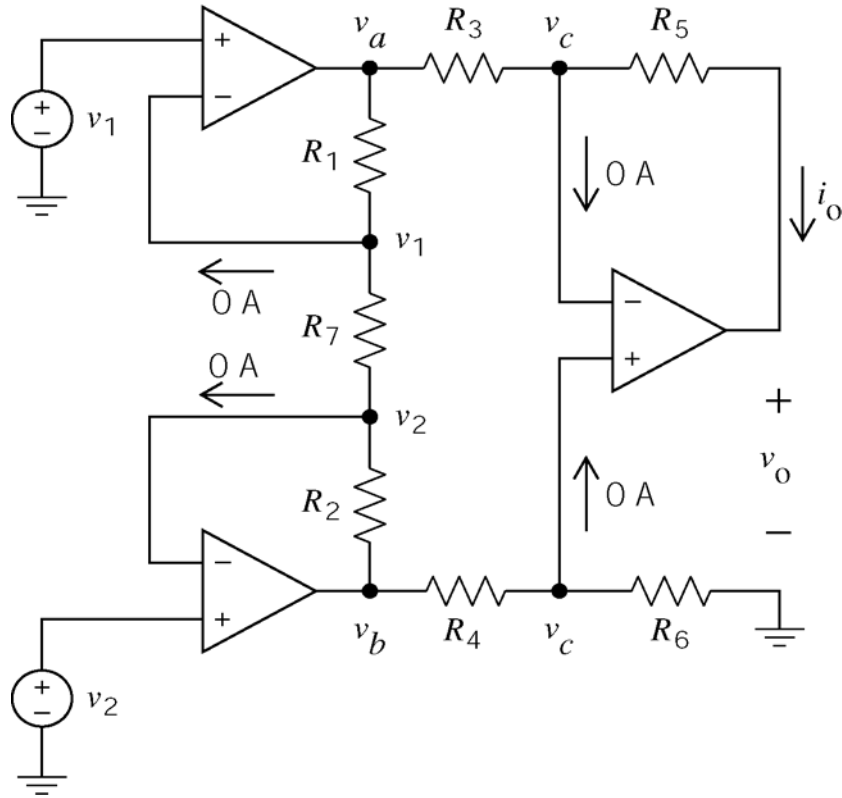

$$\frac{v_1 - v_a}{R_1} + \frac{v_1 - v_2}{R_7} + 0 = 0 \Rightarrow v_a = \left(1 + \frac{R_1}{R_7}\right)v_1 - \frac{R_1}{R_7}v_2$$

$$\frac{v_2 - v_b}{R_2} - \frac{v_1 - v_2}{R_7} + 0 = 0 \Rightarrow v_b = \left(1 + \frac{R_2}{R_7}\right)v_2 - \frac{R_2}{R_7}v_1$$

$$-\left(\frac{v_b - v_c}{R_4}\right) + \frac{v_c - 0}{R_6} + 0 = 0 \Rightarrow v_c = \frac{R_6}{R_4 + R_6}v_b$$

$$-\left(\frac{v_a - v_c}{R_3}\right) + \left(\frac{v_c - v_0}{R_5}\right) + 0 = 0 \Rightarrow v_0 = -\frac{R_5}{R_3}v_a + \left(1 + \frac{R_5}{R_3}\right)v_c$$

$$v_0 = \left[\frac{R_5 R_1}{R_3 R_7} + \frac{R_6 (R_3 + R_5)}{R_3 (R_4 + R_6)} \left(1 + \frac{R_2}{R_7}\right)\right] v_2 - \left[\frac{R_5}{R_3} \left(1 + \frac{R_1}{R_7}\right) + \frac{R_6 (R_3 + R_5) R_2}{R_3 (R_4 + R_6) R_7}\right] v_1$$

$$i_0 = \frac{v_c - v_0}{R_5} = \dots$$

P6.5-6

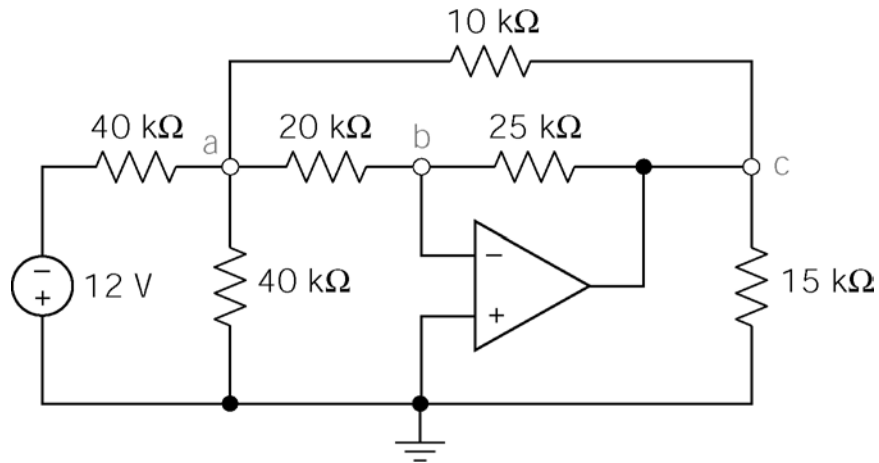

KCL at node b:

$$\frac{v_a}{20 \times 10^3} + \frac{v_c}{25 \times 10^3} = 0 \Rightarrow v_c = -\frac{5}{4} v_a$$

KCL at node a:

$$\frac{v_a - (-12)}{40 \times 10^3} + \frac{v_a}{10 \times 10^3} + \frac{v_a + 0}{20 \times 10^3} + \frac{v_a - \left(-\frac{5}{4} v_a\right)}{10 \times 10^3} = 0 \Rightarrow v_a = -\frac{12}{13} \text{ V}$$

So

$$v_c = -\frac{5}{4} v_a = -\frac{15}{13}.$$

P6.5-7

Apply KCL at the inverting input node of the op amp

$$-\left(\frac{v_a - 0}{10000}\right) + 0 - \left(\frac{(v_a + 6) - 0}{30000}\right) = 0$$

$$\Rightarrow v_a = -1.5 \text{ V}$$

Apply KCL to the super node corresponding the voltage source:

$$\frac{v_a - 0}{10000} + \frac{v_a + 6 - 0}{30000}$$

$$+ \frac{v_a - v_b}{30000} + \frac{(v_a + 6) - v_b}{10000} = 0$$

$$\Rightarrow 3v_a + v_a + 6 + v_a - v_b$$

$$+ 3[(v_a + 6) - v_b] = 0$$

$$\Rightarrow v_b = 2v_a + 6 = 3 \text{ V}$$

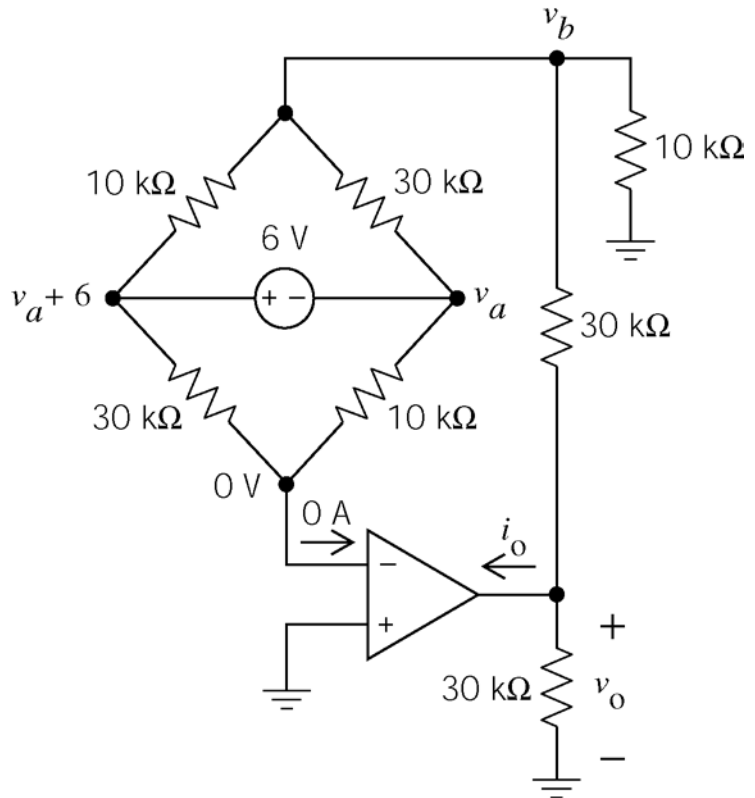

Apply KCL at node b:

$$\frac{v_b}{10000} + \frac{v_b - v_o}{30000} - \left(\frac{v_a - v_b}{30000}\right) - \left(\frac{(v_a + 6) - v_b}{10000}\right) = 0$$

$$\Rightarrow 3v_b + (v_b - v_o) - (v_a - v_b) - 3[(v_a + 6) - v_b] = 0$$

$$\Rightarrow v_o = 8v_b - 4v_a - 18 = \underline{12 \text{ V}}$$

Apply KCL at the output node of the op amp:

$$i_o + \frac{v_o}{30000} + \frac{v_o - v_b}{30000} = 0 \Rightarrow i_o = -0.7 \text{ mA}$$

P6.5-8

Apply KVL to the bottom mesh:

$$-i_o(10000) - i_o(20000) + 5 = 0$$

$$\Rightarrow i_o = \frac{1}{6} \text{ mA}$$

The node voltages at the input nodes of an ideal op amp are equal. Consequently

$$v_a = 10000 i_o = \frac{10}{6} \text{ V}$$

Apply KCL at node a :

$$\frac{v_a}{10000} + \frac{v_a - v_o}{20000} = 0 \Rightarrow v_o = 3v_a = 5 \text{ V}$$

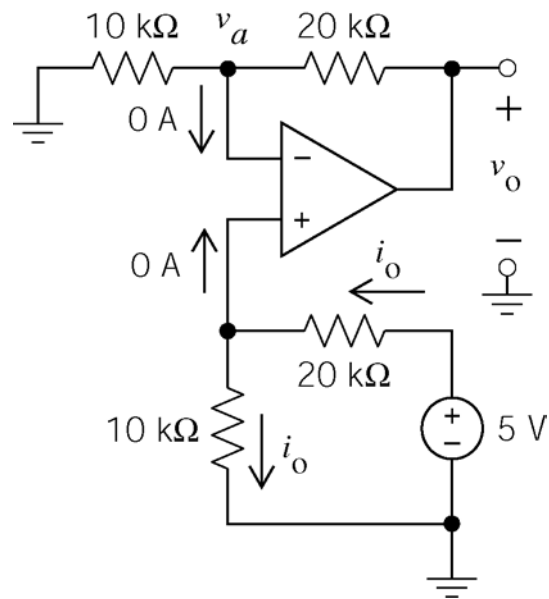

P6.5-9

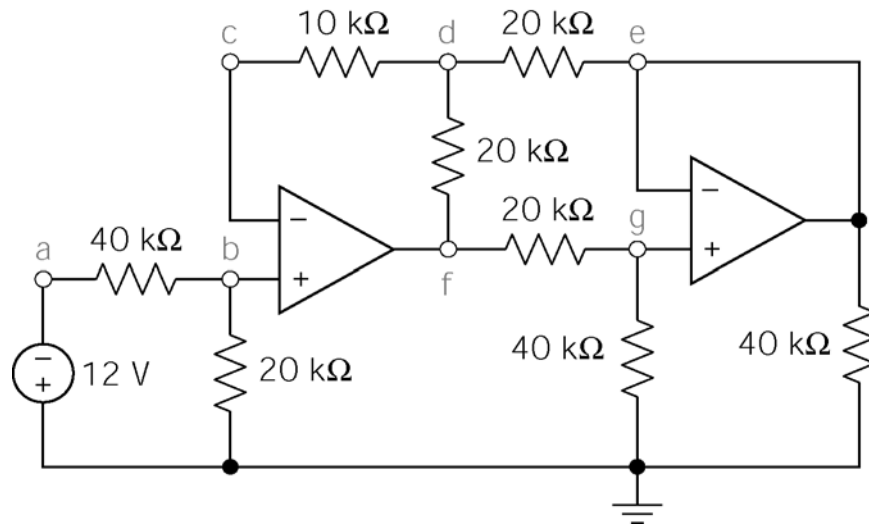

KCL at node b :
$$\frac{v_b + 12}{40000} + \frac{v_b}{20000} = 0 \Rightarrow v_b = -4 \text{ V}$$

The node voltages at the input nodes of an ideal op amp are equal, so $v_c = v_b = -4 \text{ V}$.

The node voltages at the input nodes of an ideal op amp are equal, so $v_d = v_c + 0 \times 10^4 = -4 \text{ V}$.

KCL at node g :
$$-\left(\frac{v_f - v_g}{20 \times 10^3}\right) + \frac{v_g}{40 \times 10^3} = 0 \Rightarrow v_g = \frac{2}{3} v_f$$

The node voltages at the input nodes of an ideal op amp are equal, so $v_e = v_g = \frac{2}{3}v_f$.

$$\text{KCL at node d: } 0 = \frac{v_d - v_f}{20 \times 10^3} + \frac{v_d - v_e}{20 \times 10^3} = \frac{v_d - v_f}{20 \times 10^3} + \frac{v_d - \frac{2}{3}v_f}{20 \times 10^3} \Rightarrow v_f = \frac{6}{5}v_d = -\frac{24}{5} \text{ V}$$

$$\text{Finally, } v_e = v_g = \frac{2}{3}v_f = -\frac{16}{5} \text{ V.}$$

P6.5-10

By voltage division (or by applying KCL at node a)

$$v_a = \frac{R_0}{R_1 + R_0} v_s$$

Applying KCL at node b :

$$\begin{aligned} \frac{v_b - v_s}{R_1} + \frac{v_b - v_0}{R_0 + \Delta R} &= 0 \\ \Rightarrow \frac{R_0 + \Delta R}{R_1} (v_b - v_s) + v_b &= v_0 \end{aligned}$$

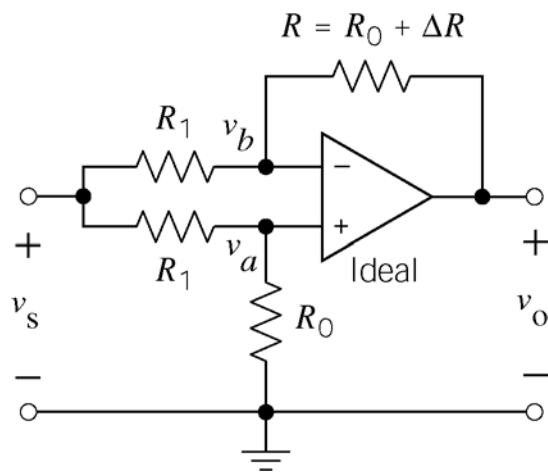

The node voltages at the input nodes of an ideal op amp are equal so $v_b = v_a$.

$$v_0 = \left[\left(\frac{R_0 + \Delta R}{R_1} + 1 \right) \frac{R_0}{R_1 + R_0} - \frac{R_0 + \Delta R}{R_1} \right] v_s = -\frac{\Delta R}{R_1 + R_0} v_s = \left(-v_s \frac{R_0}{R_1 + R_0} \right) \frac{\Delta R}{R_0}$$

Section 6-6: Design Using Operational Amplifier

P6.6-1

Use the current-to-voltage converter, entry (g) in Figure 6.6-1.

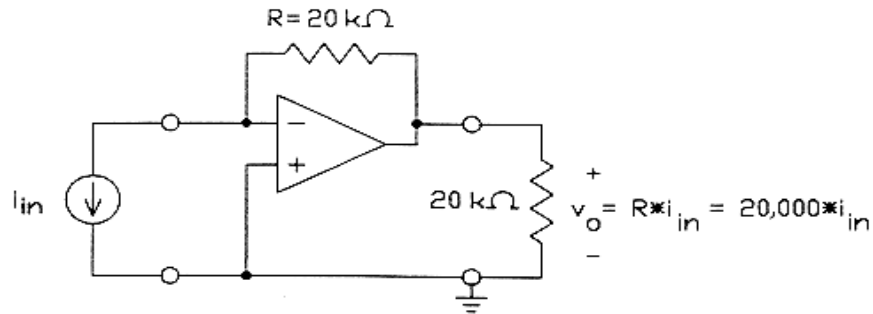

P6.6-2

Use the voltage-controlled current source, entry (i) in Figure 6.6-1.

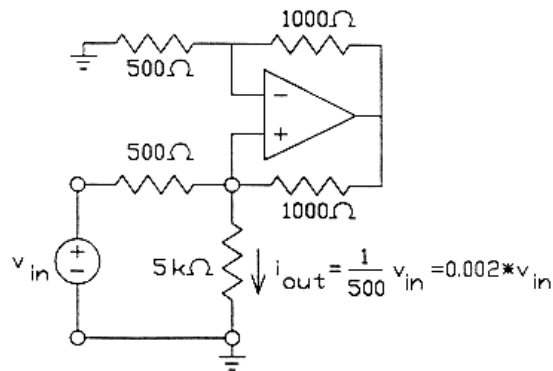

P6.6-3

Use the noninverting summing amplifier, entry (e) in Figure 6.6-1.

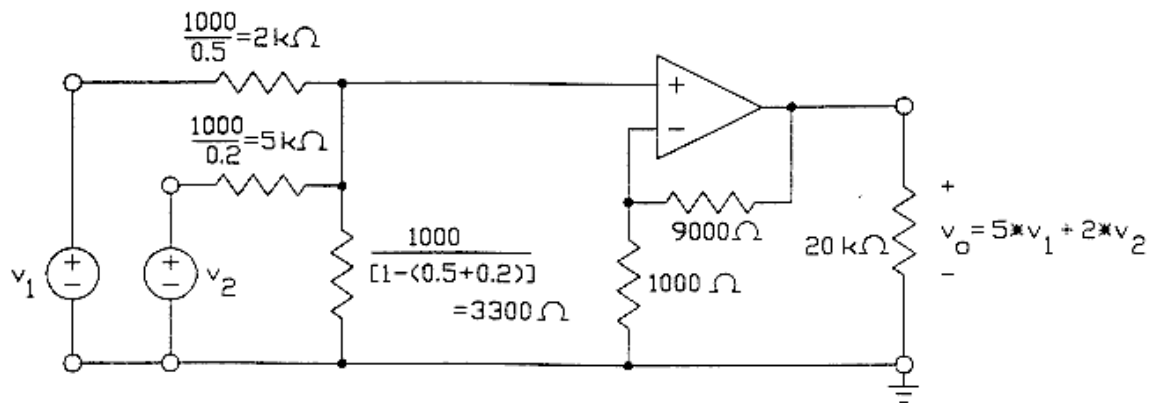

P6.6-4

Use the difference amplifier, entry (f) in Figure 6.6-1.

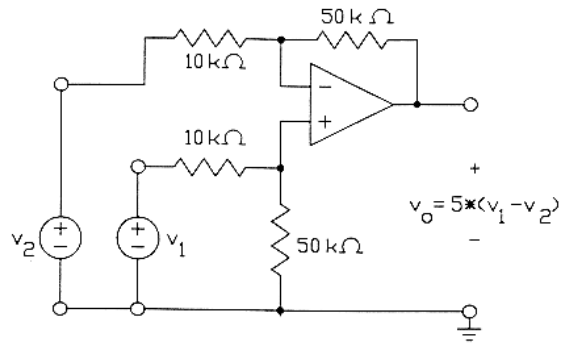

P6.6-5

Use the inverting amplifier and the summing amplifier, entries (a) and (d) in Figure 6.6-1.

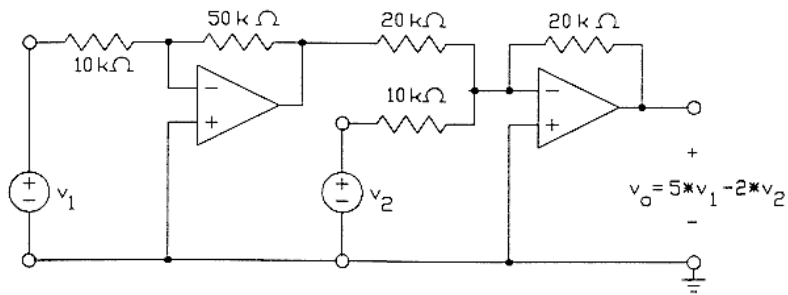

P6.6-6

Use the negative resistance converter, entry (h) in Figure 6.6-1.

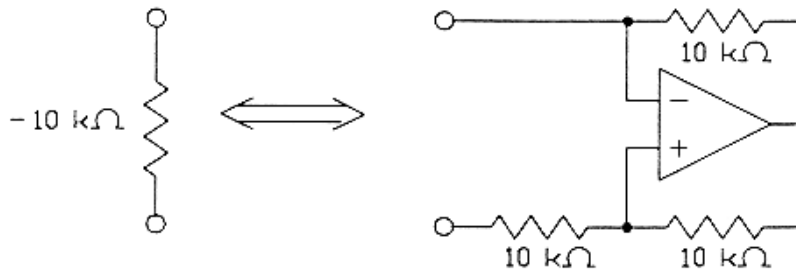

P6.6-7

Use the noninverting amplifier, entry (b) in Figure 6.6-1. Notice that the ideal op amp forces the current i_{in} to be zero.

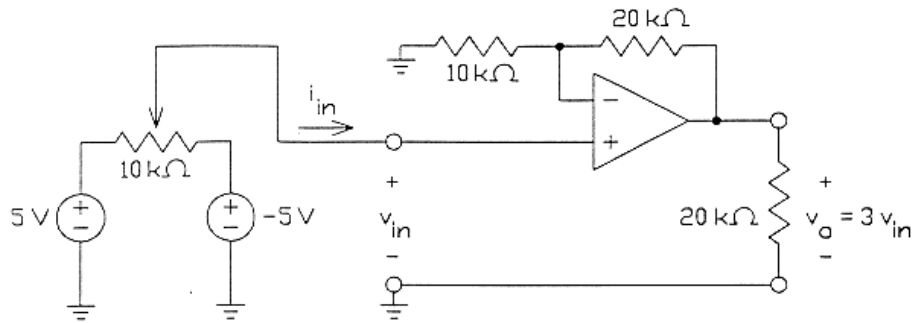

P6.6-8

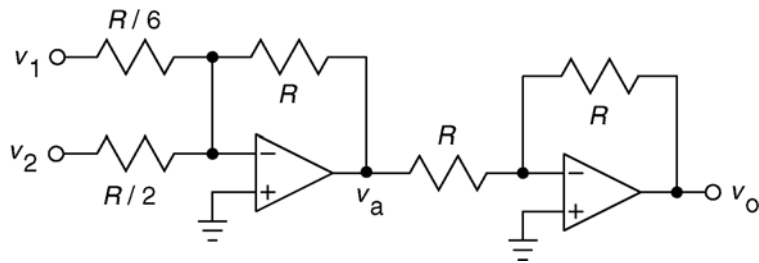

$$\left. \begin{array}{l} \text{Summing Amplifier: } v_a = -(6v_1 + 2v_2) \\ \text{Inverting Amplifier: } v_o = -v_a \end{array} \right\} \Rightarrow v_o = 6v_1 + 2v_2$$

P6.6-9

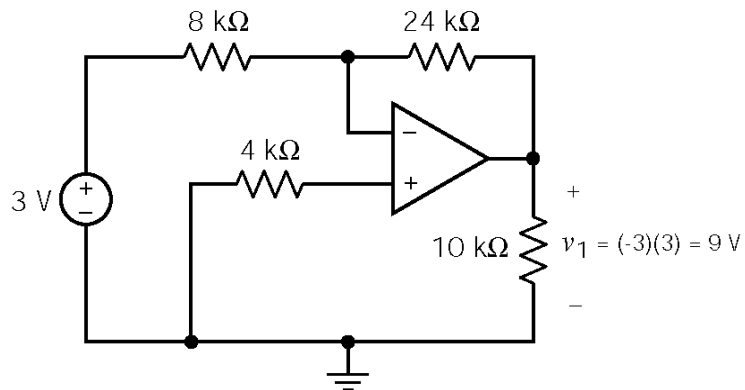

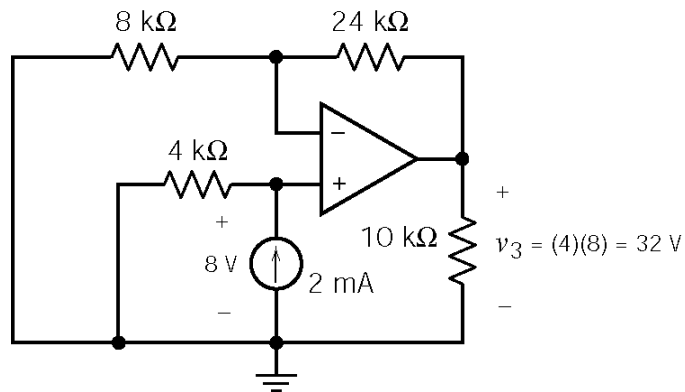
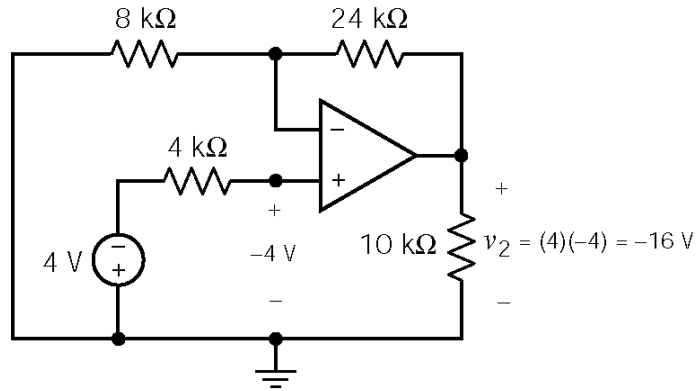

Using superposition, $v_o = v_1 + v_2 + v_3 = -9 - 16 + 32 = 7 \text{ V}$

P6.6-10

R_1	6	12	24	$6 \parallel 12$	$6 \parallel 24$
R_2	$12 \parallel 12 \parallel 24$	$6 \parallel 12 \parallel 24$	$6 \parallel 12 \parallel 12$	$12 \parallel 24$	$12 \parallel 12$
$-v_o/v_s$	0.8	0.286	0.125	2	1.25

R_1	$12 \parallel 12$	$12 \parallel 24$	$6 \parallel 12 \parallel 12$	$6 \parallel 12 \parallel 24$	$12 \parallel 12 \parallel 24$
R_2	$6 \parallel 24$	$6 \parallel 12$	24	12	6
$-v_o/v_s$	0.8	0.5	8	3.5	1.25

Section 6-7: Operational Amplifier Circuits and Linear Algebraic Equations

P6.7-1

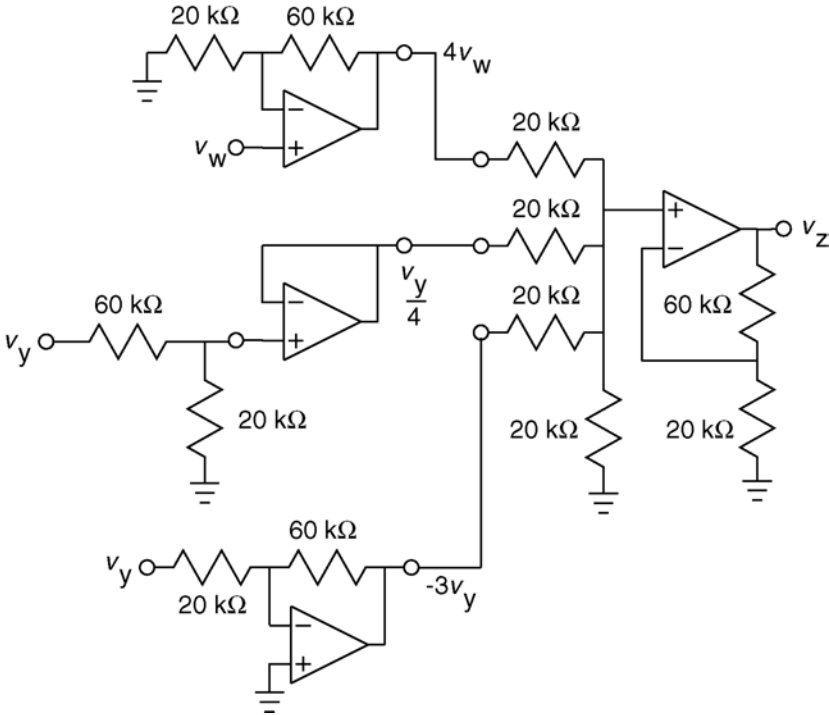

P6.7-2

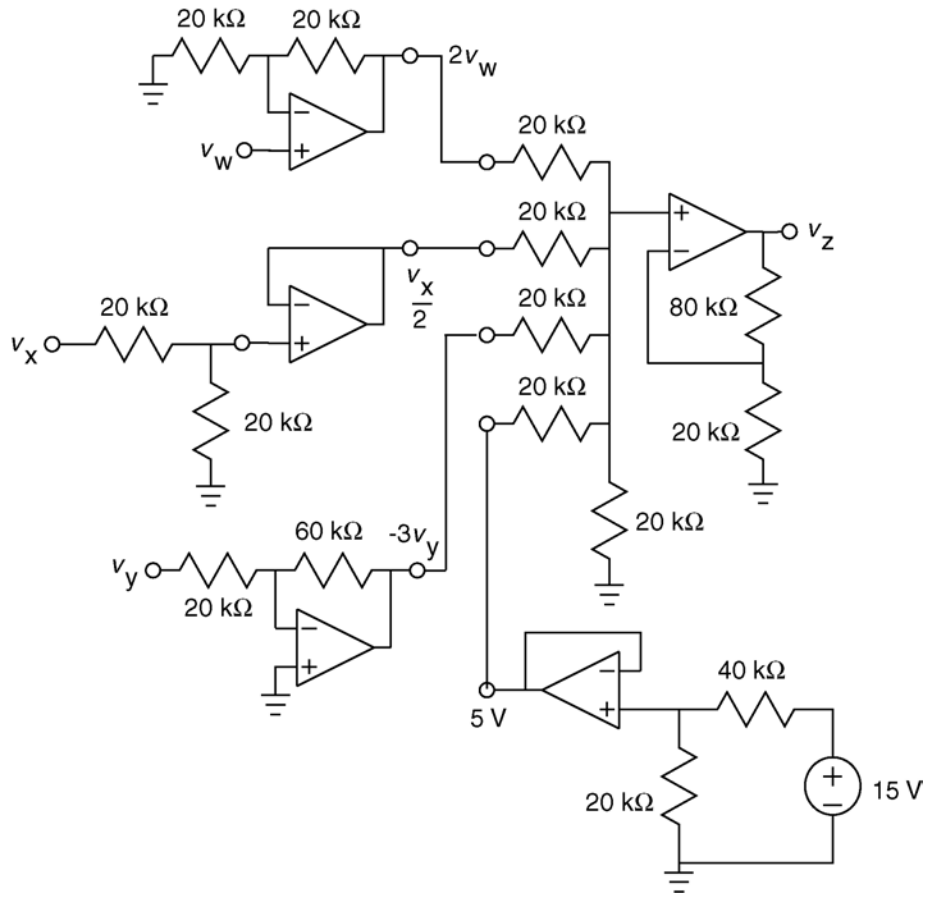

Section 6-8: Characteristics of the Practical Operational Amplifier

P6.8-1

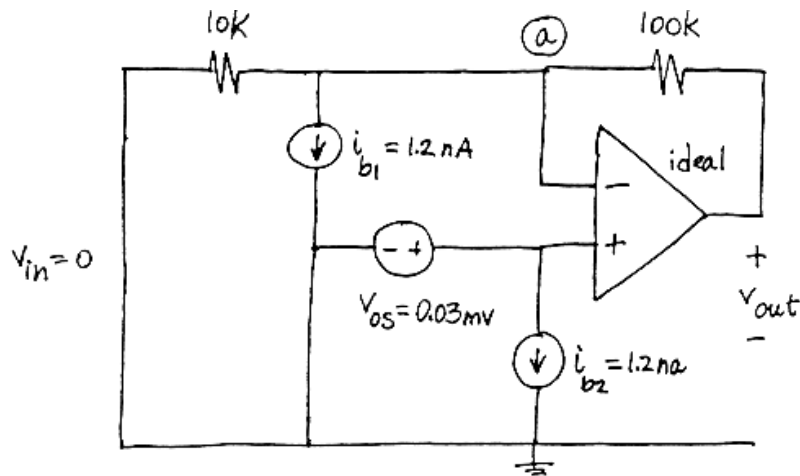

The node equation at node a is:
$$\frac{v_{out} - v_{os}}{100 \times 10^3} = \frac{v_{os}}{10 \times 10^3} + i_{b1}$$

Solving for v_{out} :

$$\begin{aligned} v_{out} &= \left(1 + \frac{100 \times 10^3}{10 \times 10^3}\right) v_{os} + (100 \times 10^3) i_{b1} = 11v_{os} + (100 \times 10^3) i_{b1} \\ &= 11(0.03 \times 10^{-3}) + (100 \times 10^3)(1.2 \times 10^{-9}) = 0.45 \text{ mV} \end{aligned}$$

P6.8-2

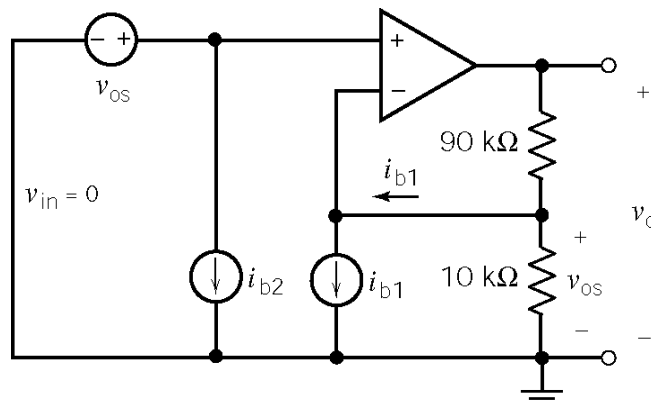

The node equation at node a is:
$$\frac{v_{os}}{10000} + i_{b1} = \frac{v_o - v_{os}}{90000}$$

Solving for v_o :

$$\begin{aligned} v_o &= \left(1 + \frac{90 \times 10^3}{10 \times 10^3}\right) v_{os} + (90 \times 10^3) i_{b1} = 10 v_{os} + (90 \times 10^3) i_{b1} \\ &= 10(5 \times 10^{-3}) + (90 \times 10^3)(.05 \times 10^{-9}) = 50.0045 \times 10^{-3} \approx \underline{50 \text{ mV}} \end{aligned}$$

P6.8-3

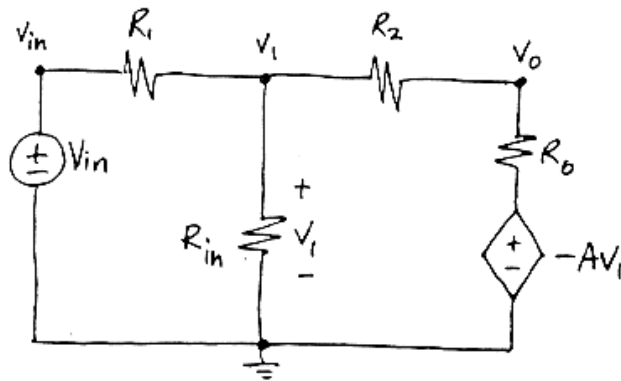

$$\left. \begin{aligned} \frac{v_1 - v_{in}}{R_1} + \frac{v_1}{R_{in}} + \frac{v_1 - v_0}{R_2} &= 0 \\ \frac{v_0 + Av_1}{R_0} + \frac{v_0 - v_1}{R_2} &= 0 \end{aligned} \right\} \Rightarrow \frac{v_0}{v_{in}} = \frac{R_{in}(R_0 - AR_2)}{(R_1 + R_{in})(R_0 + R_2) + R_1 R_{in}(1 + A)}$$

P6.8-4

a) $\frac{v_0}{v_{in}} = -\frac{R_2}{R_1} = -\frac{49 \times 10^3}{5.1 \times 10^3} = \underline{-9.6078}$

b) $\frac{v_0}{v_{in}} = \frac{(2 \times 10^6)(75 - (200,000)(50 \times 10^3))}{(5 \times 10^3 + 2 \times 10^6)(75 + 50 \times 10^3) + (5 \times 10^3)(2 \times 10^6)(1 + 200,000)} = \underline{-9.9957}$

c) $\frac{v_0}{v_{in}} = \frac{2 \times 10^6(75 - (200,000)(49 \times 10^3))}{(5.1 \times 10^3 + 2 \times 10^6)(75 + 49 \times 10^3) + (5.1 \times 10^3)(2 \times 10^6)(1 + 200,000)} = \underline{-9.6037}$

P6.8-5

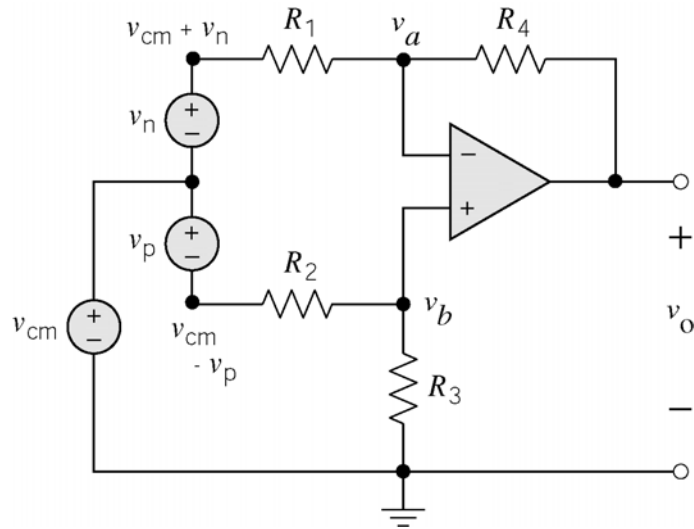

Apply KCL at node b :

$$v_b = \frac{R_3}{R_2 + R_3}(v_{cm} - v_p)$$

Apply KCL at node a :

$$\frac{v_a - v_o}{R_4} + \frac{v_a - (v_{cm} + v_n)}{R_1} = 0$$

The voltages at the input nodes of an ideal op amp are equal so

$$v_a = v_b.$$

$$v_o = -\frac{R_4}{R_1}(v_{cm} + v_n) + \frac{R_4 + R_1}{R_1}v_a$$

$$v_o = -\frac{R_4}{R_1}(v_{cm} + v_n) +$$

$$\frac{(R_4 + R_1)R_3}{R_1(R_2 + R_3)}(v_{cm} - v_p)$$

when $\frac{R_4}{R_1} = \frac{R_3}{R_2}$ then $\frac{(R_4 + R_1)R_3}{R_1(R_2 + R_3)} = \frac{\frac{R_4}{R_1} + 1}{\frac{R_3}{R_2} + 1} \times \frac{R_3}{R_2} = \frac{R_4}{R_1}$

so

$$v_o = -\frac{R_4}{R_1}(v_{cm} + v_n) + \frac{R_4}{R_1}(v_{cm} - v_p) = -\frac{R_4}{R_1}(v_n + v_p)$$

PSpice Problems

SP6-1:

(a)
$$v_z = a v_w + b v_x + c v_y$$

The following three PSpice simulations show

$$1 \text{ V} = v_z = a \text{ when } v_w = 1 \text{ V, } v_x = 0 \text{ V and } v_y = 0 \text{ V}$$

$$4 \text{ V} = v_z = b \text{ when } v_w = 0 \text{ V, } v_x = 1 \text{ V and } v_y = 0 \text{ V}$$

$$-5 \text{ V} = v_z = c \text{ when } v_w = 0 \text{ V, } v_x = 0 \text{ V and } v_y = 1 \text{ V}$$

Therefore

$$v_z = v_w + 4 v_x - 5 v_y$$

(b) When $v_w = 2 \text{ V}$:

$$v_z = 4 v_x - 5 v_y + 2$$

1 V = $v_z = a$ when $v_w = 1 \text{ V}$, $v_x = 0 \text{ V}$ and $v_y = 0 \text{ V}$:

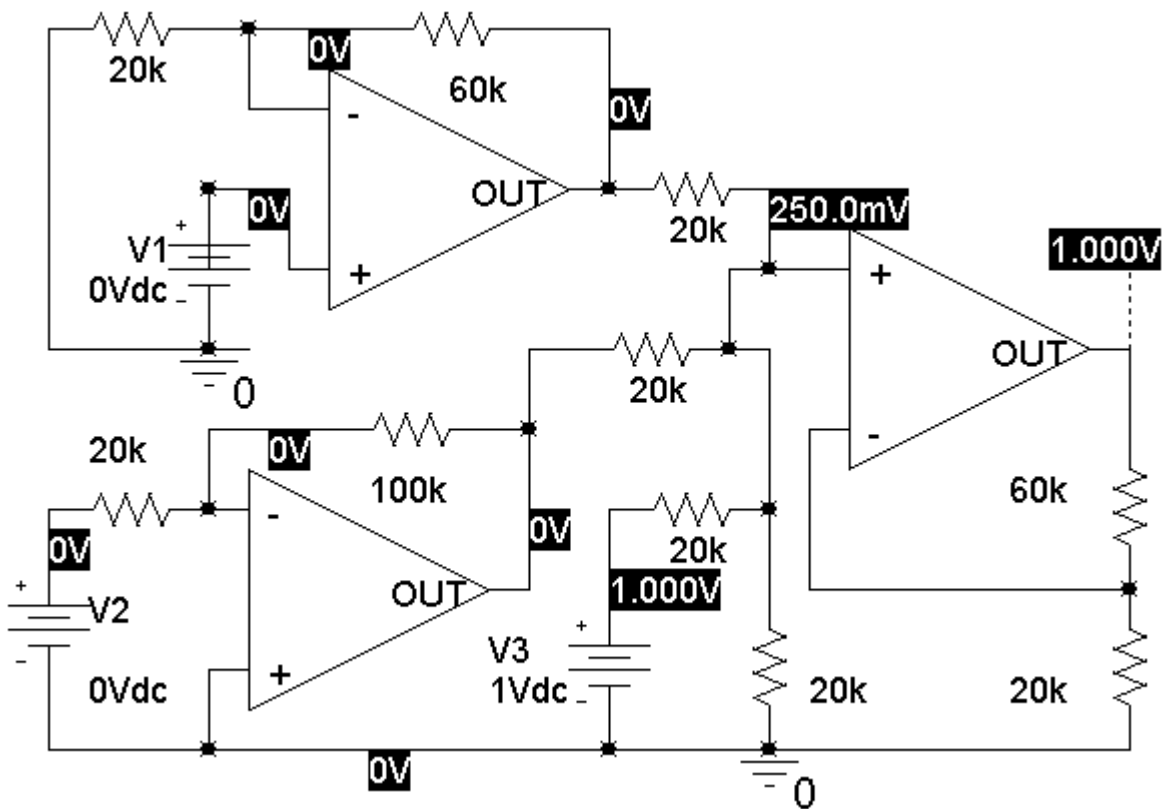

$4\text{ V} = v_z = b$ when $v_w = 0\text{ V}$, $v_x = 1\text{ V}$ and $v_y = 0\text{ V}$:

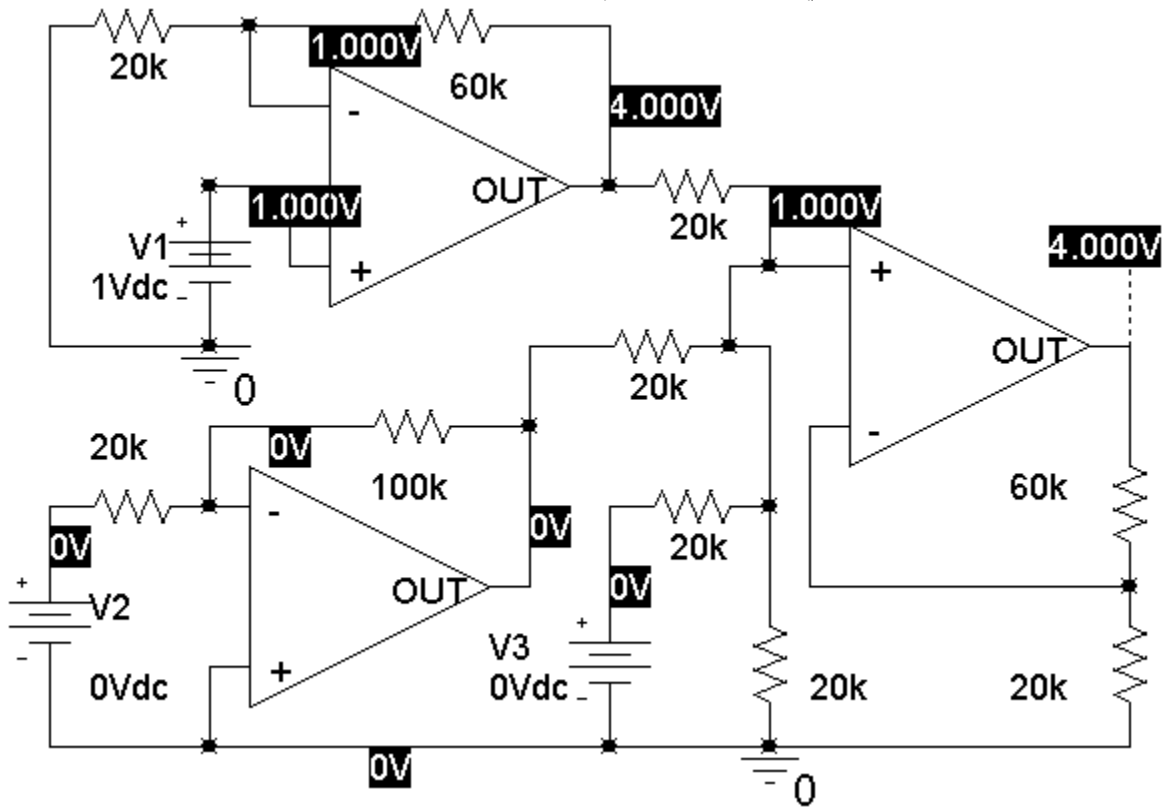

$-5\text{ V} = v_z = c$ when $v_w = 0\text{ V}$, $v_x = 0\text{ V}$ and $v_y = 1\text{ V}$:

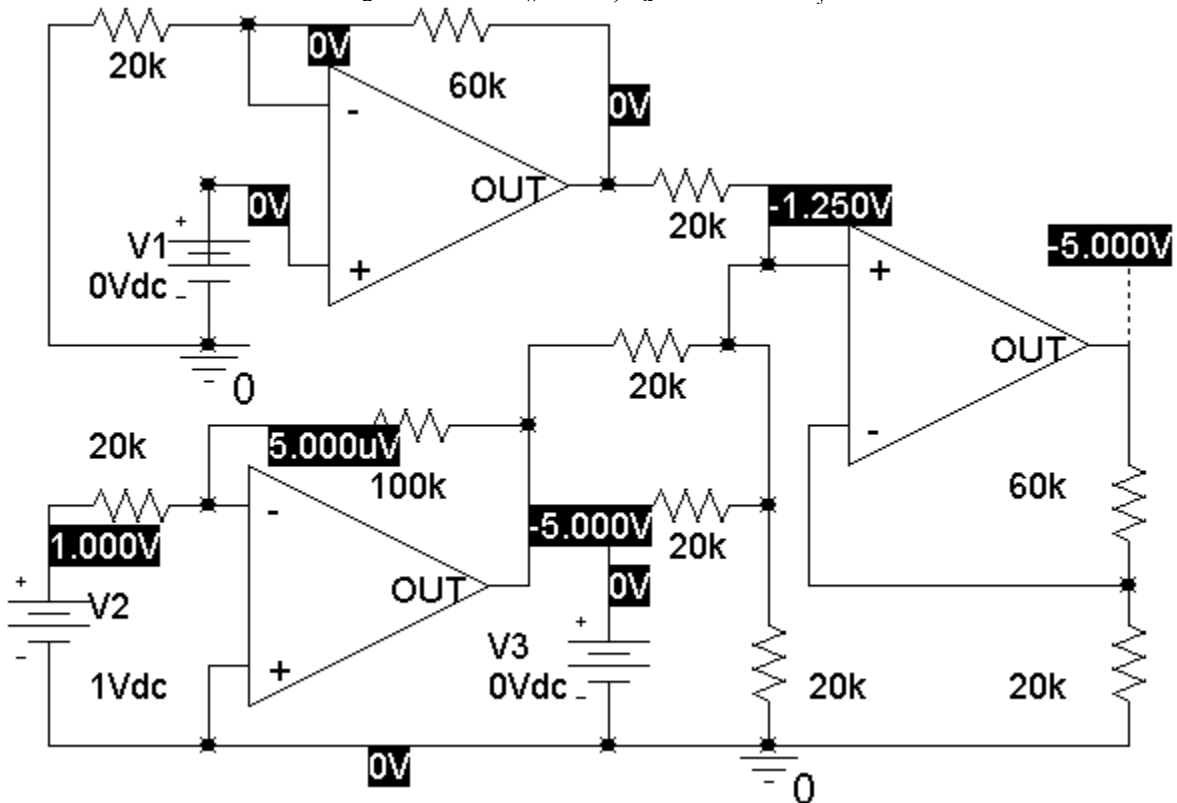

SP6-2

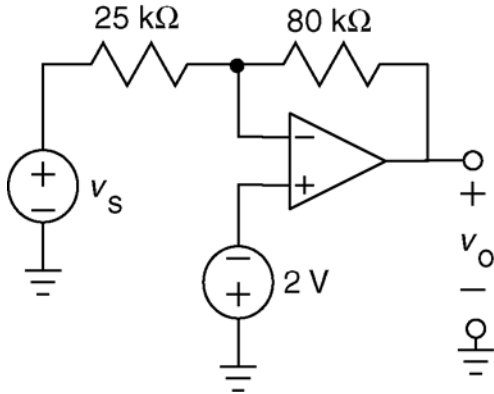

a) Using superposition and recognizing the inverting and noninverting amplifiers:

$$v_o = -\frac{80}{25} v_s + \left(1 + \frac{80}{25}\right)(-2) = -3.2 v_s - 8.4$$

b) Using the DC Sweep feature of PSpice produces the plot show below. Two points have been labeled in anticipation of c).

c) Notice that the equation predicts

$$(-3.2)(-5) - 8.4 = 7.6$$

and

$$(-3.2)(0) - 8.4 = -8.4$$

Both agree with labeled points on the plot.

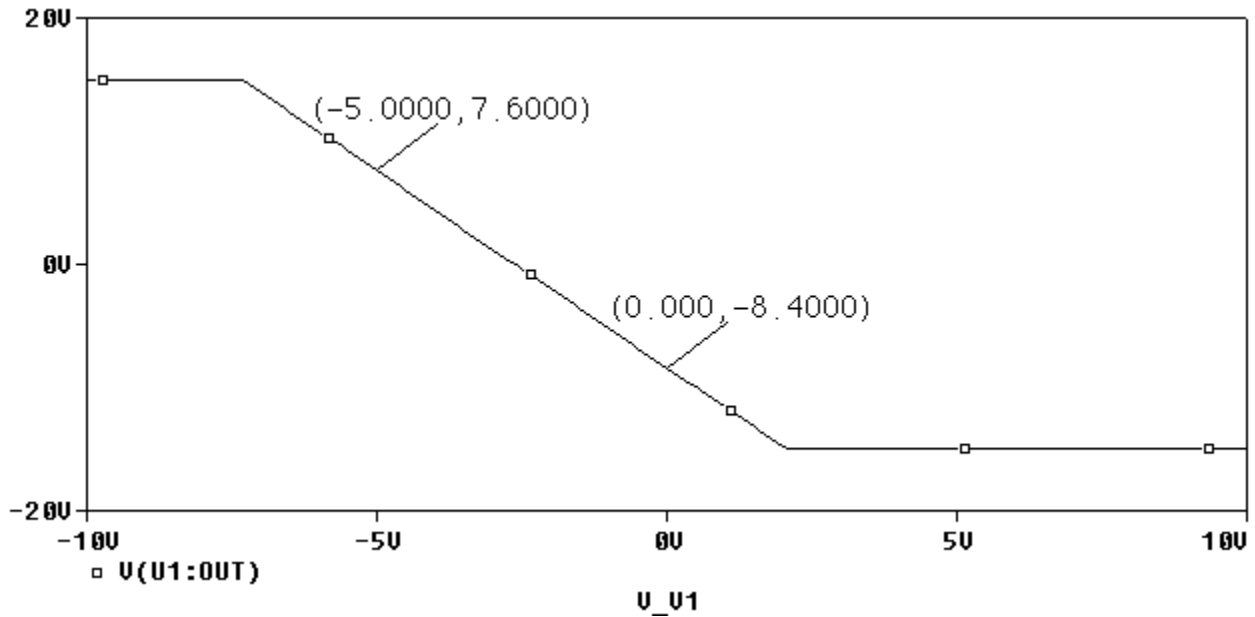

SP6-3

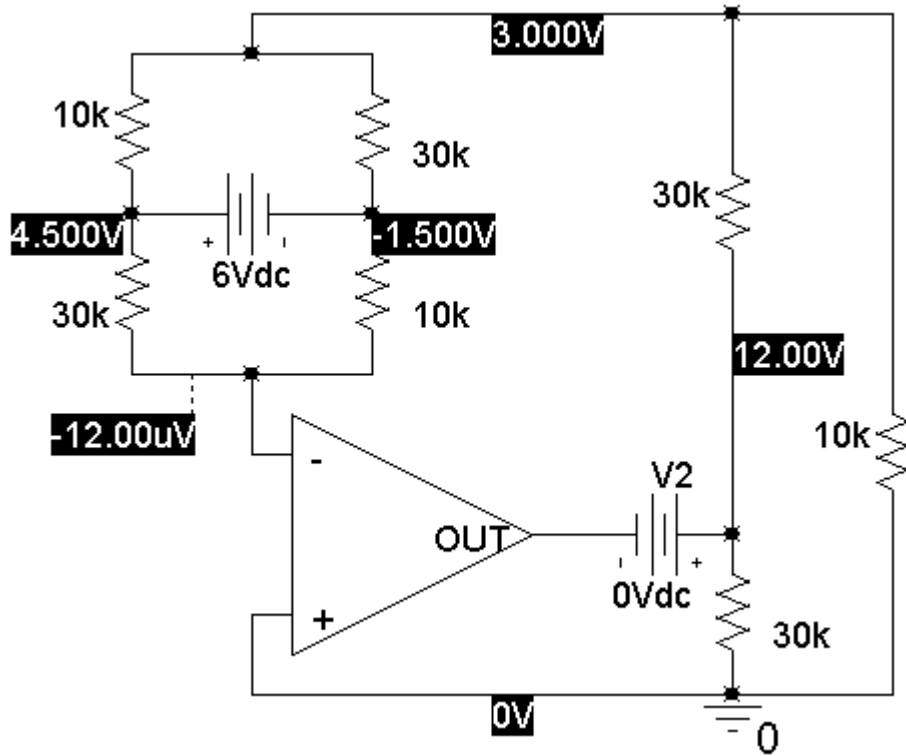

VOLTAGE SOURCE CURRENTS

NAME	CURRENT
V_V1	-3.000E-04
V_V2	-7.000E-04

$$v_{34} = -1.5 - -12 \times 10^{-6} \cong -1.5 \text{ V}$$

$$v_{23} = 4.5 - (-1.5) = 6 \text{ V}$$

$$v_{50} = 12 - 0 = 12 \text{ V}$$

$$i_o = -7 \times 10^{-4} = -0.7 \text{ mA}$$

SP6-4

V4 is a short circuit used to measure i_o .

The input of the VCCS is the voltage of the left-hand voltage source. (The nominal value of the input is 20 mV.) The output of the VCCS is i_o .

A plot of the output of the VCCS versus the input is shown below.

The gain of the VCVS is

$$gain = \frac{50 \times 10^{-6} - (-50 \times 10^{-6})}{100 \times 10^{-3} - (-100 \times 10^{-3})} = \frac{1}{2} \times 10^{-3} \frac{A}{V}$$

(The op amp saturates for the inputs larger than 0.1 V, limiting the operating range of this VCCS.)

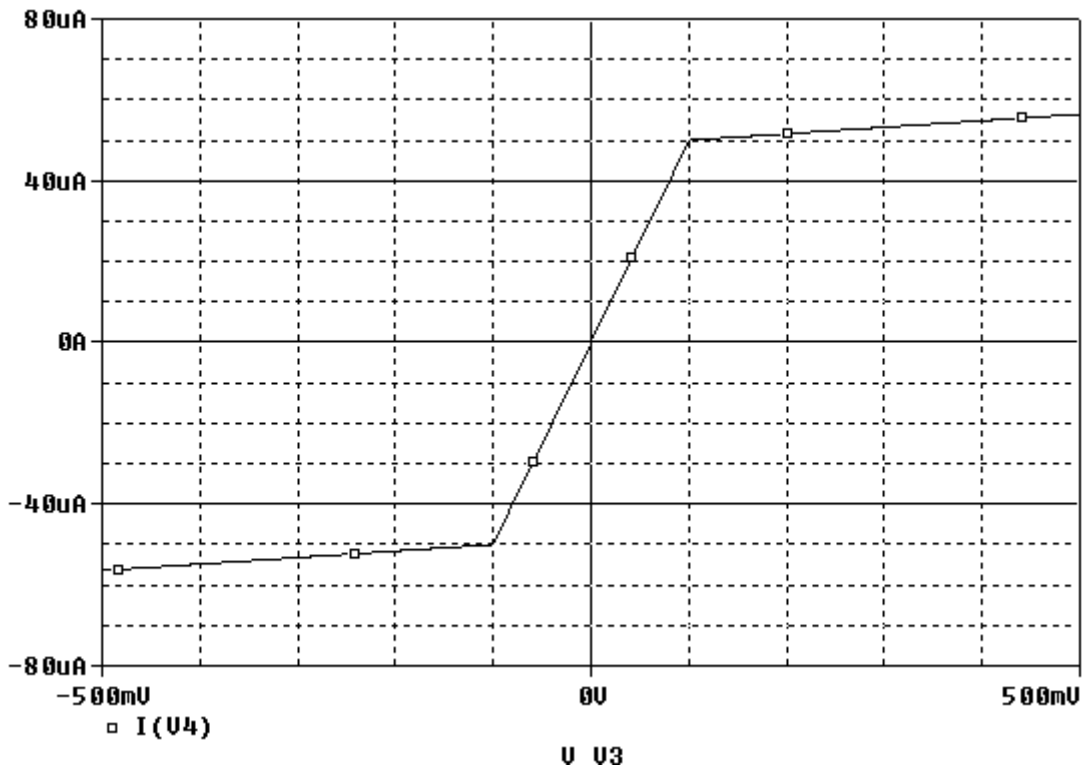
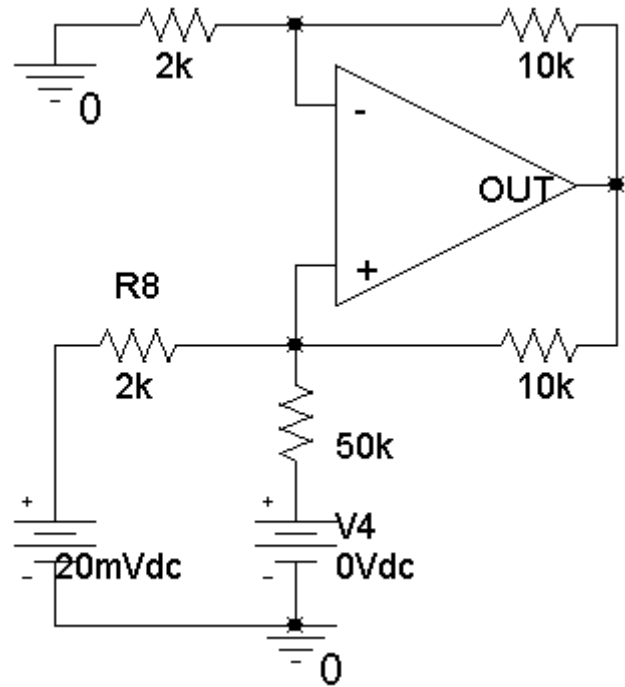

Verification Problems

VP6-1

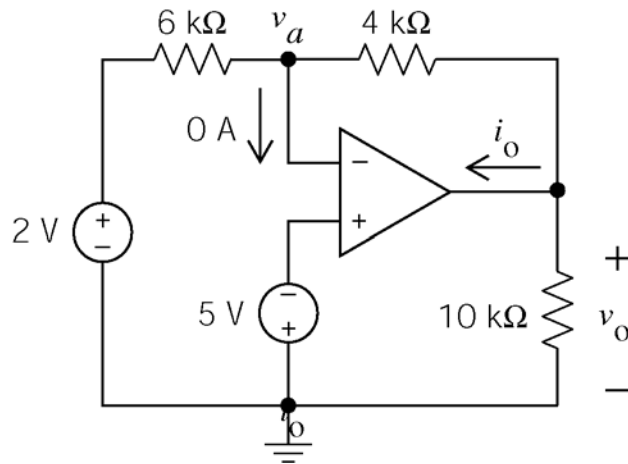

Apply KCL at the output node of the op amp

$$i_o = \frac{v_o}{10000} + \frac{v_o - (-5)}{4000} = 0$$

Try the given values: $i_o = -1 \text{ mA}$ and $v_o = 7 \text{ V}$

$$-1 \times 10^{-3} \neq 3.7 \times 10^{-3} = \frac{7}{10000} + \frac{7 - (-5)}{4000}$$

KCL is not satisfied. These cannot be the correct values of i_o and v_o .

VP6-2

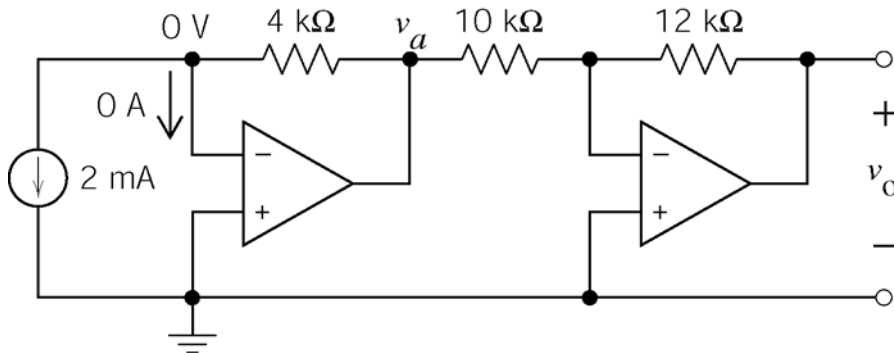

$$v_a = (4 \times 10^3)(2 \times 10^{-3}) = 8 \text{ V}$$

$$v_o = -\frac{12 \times 10^3}{10 \times 10^3} v_a = -1.2(8) = -9.6 \text{ V}$$

So $v_o = -9.6 \text{ V}$ instead of 9.6 V .

VP6-3

First, redraw the circuit as:

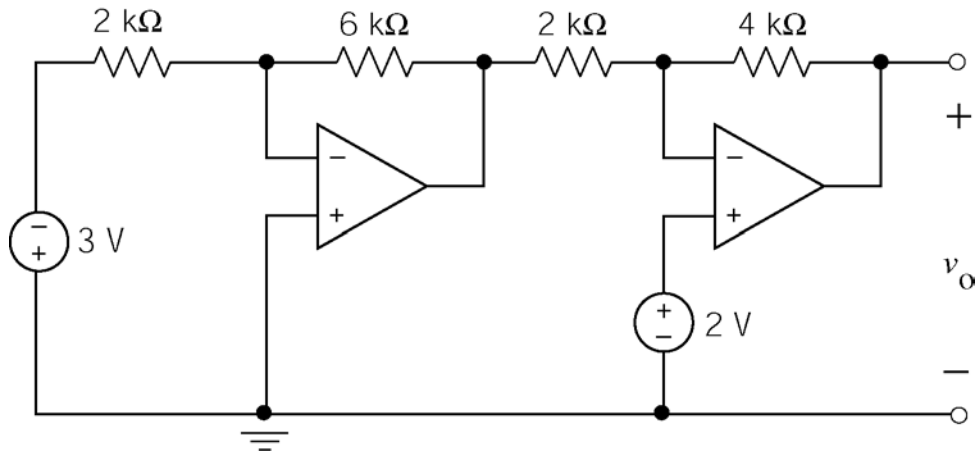

Then using superposition, and recognizing of the inverting and noninverting amplifiers:

$$v_o = \left(-\frac{6}{2}\right)\left(-\frac{4}{2}\right)(-3) + \left(1 + \frac{4}{2}\right)(2) = -18 + 6 = -12 \text{ V}$$

The given answer is correct.

VP6-4

First notice that $v_e = v_f = v_c$ is required by the ideal op amp. (There is zero current into the input lead of an ideal op amp so there is zero current in the 10 kΩ connected between nodes e and f, hence zero volts across this resistor. Also, the node voltages at the input nodes of an ideal op amp are equal.)

The given voltages satisfy all the node equations at nodes b, c and d:

node b:
$$\frac{0 - (-5)}{10000} + \frac{0}{40000} + \frac{0 - 2}{4000} = 0$$

node c:
$$\frac{0 - 2}{4000} = \frac{2 - 5}{6000} + 0$$

node d:
$$\frac{2 - 5}{6000} = \frac{5}{5000} + \frac{5 - 11}{4000}$$

Therefore, the analysis is correct.

VP6-5

The given voltages satisfy the node equations at nodes b and e:

$$\text{node b:} \quad \frac{-2.5-2}{20000} + \frac{-0.25}{40000} + \frac{-2.5-(-5)}{40000} = 0$$

$$\text{node e:} \quad \frac{-2.5-(-0.25)}{9000} \neq \frac{-0.25}{1000} + 0$$

Therefore, the analysis is not correct.

$$\text{Notice that} \quad \frac{-2.5-(+0.25)}{9000} = \frac{+0.25}{1000} + 0$$

So it appears that $v_e = +0.25$ V instead of $v_e = -0.25$ V.

Also, the circuit is an noninverting summer with $R_a = 10$ k Ω and $R_b = 1$ k Ω , $K_1 = 1/2$, $K_2 = 1/4$ and $K_4 = 9$. The given node voltages satisfy the equation

$$-2.5 = v_d = K_4 (K_1 v_a + K_2 v_c) = 10 \left(\frac{1}{2}(2) + \frac{1}{4}(-5) \right)$$

None-the-less, the analysis is not correct.

Design Problems

DP6-1

From Figure 6.6-1g, this circuit

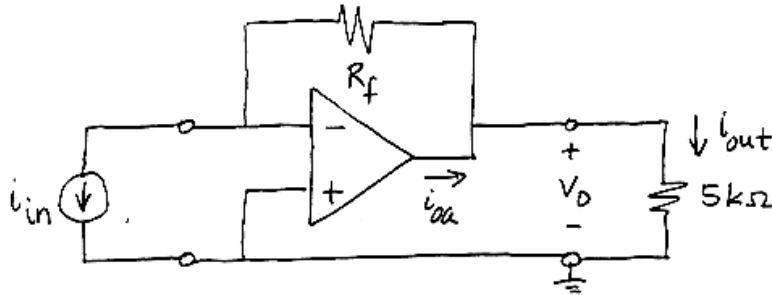

is described by $v_o = R_f i_{in}$. Since $i_{out} = \frac{v_o}{5000}$, we require $\frac{1}{4} = \frac{i_{out}}{i_{in}} = \frac{R_f}{5000}$, or $R_f = 1250 \Omega$

Notice that $i_{oa} = i_{in} + \frac{(1250)i_{in}}{5000} = \frac{5}{4}i_{in}$. To avoid current saturation requires $\frac{5}{4}i_{in} < i_{sat}$ or

$i_{in} < \frac{4}{5}i_{sat}$. For example, if $i_{sat} = 2 \text{ mA}$, then $i_{in} < 1.6 \text{ mA}$ is required to avoid current saturation.

DP6-2

$$v_o = -\frac{3}{4}v_i + 3 = -\frac{3}{4}v_i + \left(1 + \frac{3}{4}\right)\left(\frac{12}{35}\right)5 - \frac{3}{4}v_i + \left(1 + \frac{3}{4}\right)\left(\frac{12}{12+23}\right)5$$

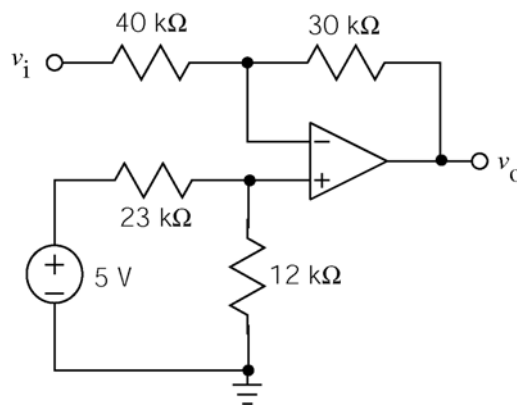

DP6-3

(a) $12v_i + 6 = 24\left(\frac{1}{2}v_i + \frac{1}{20}(5)\right) \Rightarrow K_4 = 24, K_1 = \frac{1}{2}, \text{ and } K_2 = \frac{1}{20}$. Take $R_a = 18 \text{ k}\Omega$ and $R_b = 1 \text{ k}\Omega$ to get

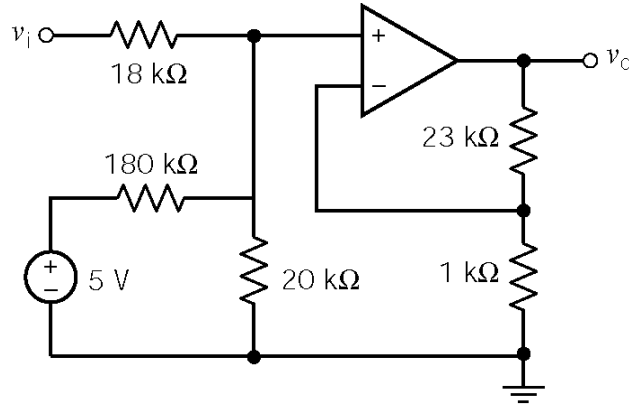

(b)

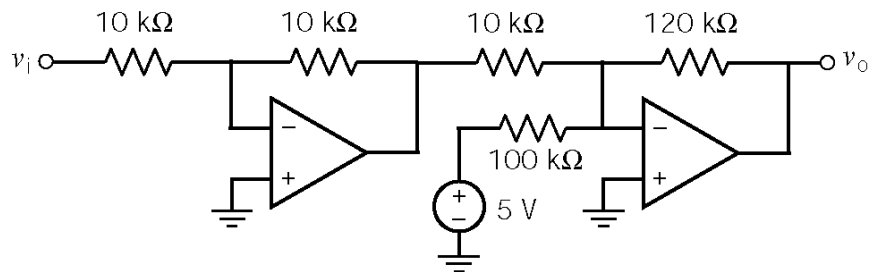

(c)

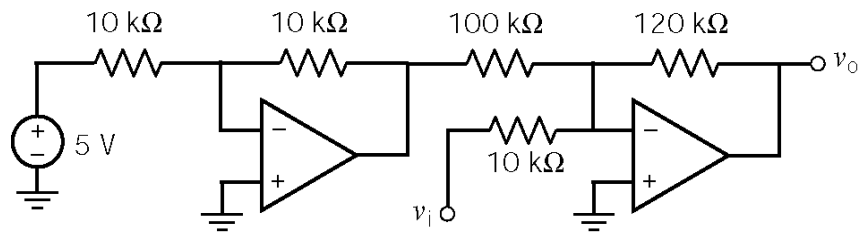

(d)

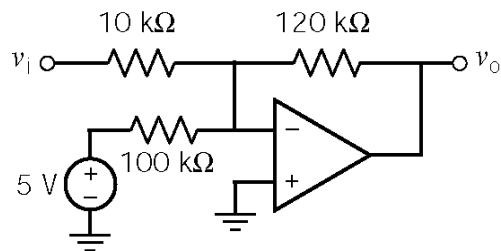

DP6-4

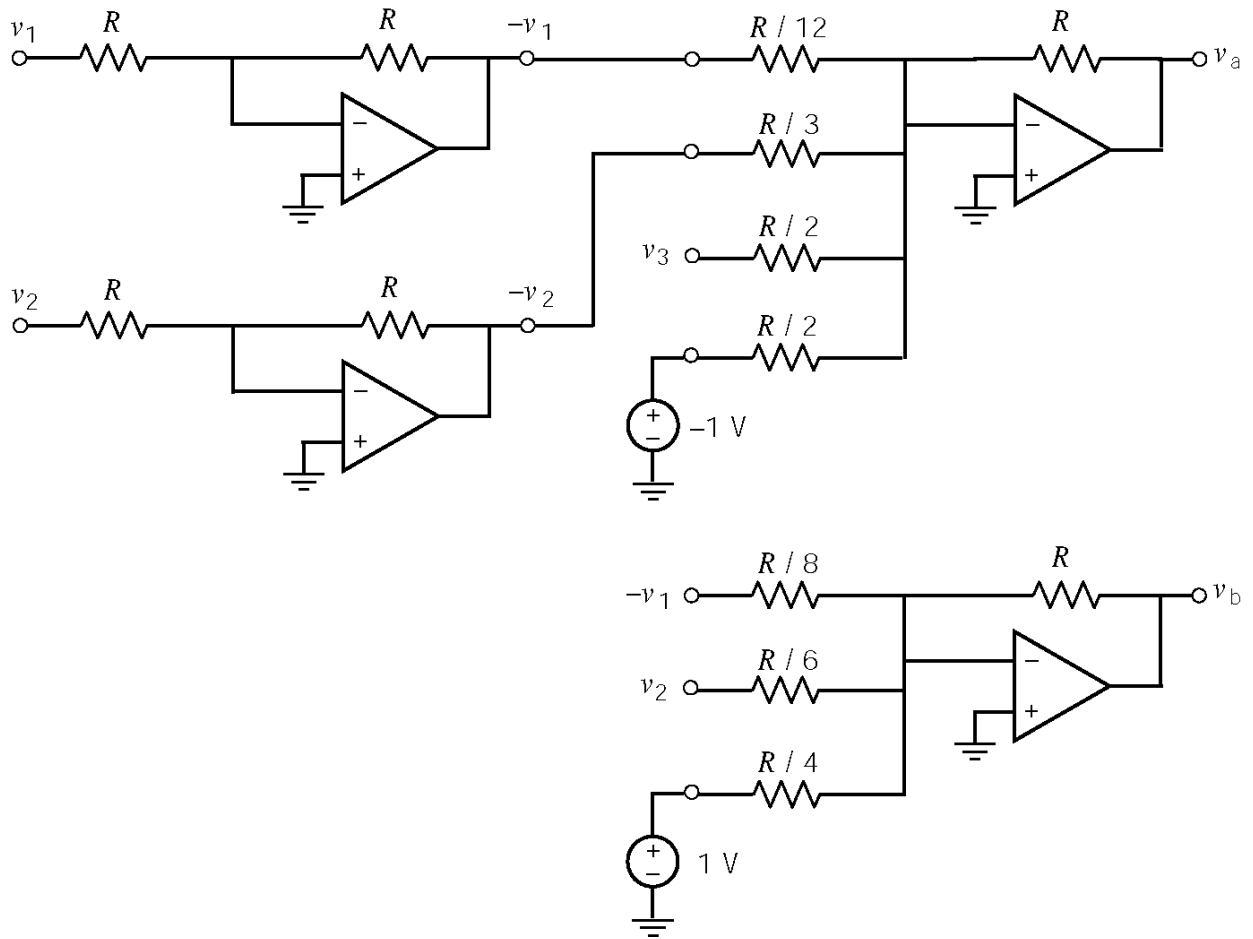

DP6-5

We require a gain of $\frac{4}{20 \times 10^{-3}} = 200$. Using an inverting amplifier:

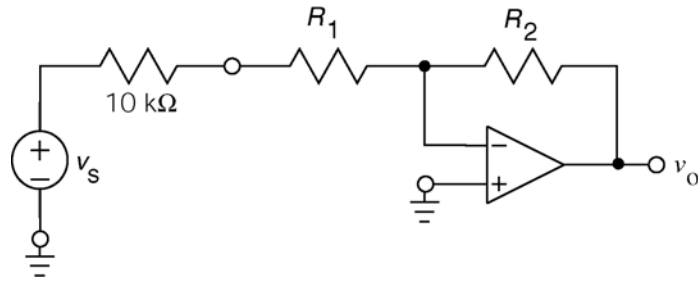

Here we have $200 = \left| -\frac{R_2}{10 \times 10^3 + R_1} \right|$. For example, let $R_1 = 0$ and $R_2 = 1 \text{ M}\Omega$. Next, using the noninverting amplifier:

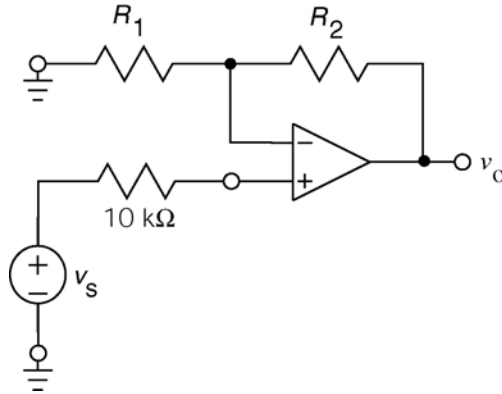

Here we have $200 = 1 + \frac{R_2}{R_1}$. For example, let $R_1 = 1 \text{ k}\Omega$ and $R_2 = 199 \text{ k}\Omega$.

The gain of the inverting amplifier circuit does not depend on the resistance of the microphone. Consequently, the gain does not change when the microphone resistance changes.

Chapter 7 Energy Storage Elements

Exercises

Ex. 7.3-1

$$i_C(t) = 1 \frac{d}{dt} v_s(t) = \begin{cases} 2 & 2 < t < 4 \\ -1 & 4 < t < 8 \\ 0 & \text{otherwise} \end{cases} \quad \text{and} \quad i_R(t) = 1 v_s(t) = \begin{cases} 2t-4 & 2 < t < 4 \\ 8-t & 4 < t < 8 \\ 0 & \text{otherwise} \end{cases}$$

so $i(t) = i_C(t) + i_R(t) = \begin{cases} 2t-2 & 2 < t < 4 \\ 7-t & 4 < t < 8 \\ 0 & \text{otherwise} \end{cases}$

Ex. 7.3-2

$$v(t) = \frac{1}{C} \int_{t_0}^t i_s(\tau) d\tau + v(t_0) = \frac{1}{\frac{1}{3}} \int_0^t i_s(\tau) d\tau - 12$$

$$v(t) = 3 \int_0^t 4 d\tau - 12 = 12t - 12 \quad \text{for } 0 < t < 4 \quad \text{In particular, } v(4) = 36 \text{ V.}$$

$$v(t) = 3 \int_4^t (-2) d\tau + 36 = 60 - 6t \quad \text{for } 4 < t < 10 \quad \text{In particular, } v(10) = 0 \text{ V.}$$

$$v(t) = 3 \int_{10}^t 0 d\tau + 0 = 0 \quad \text{for } 10 < t$$

Ex. 7.4-1

$$w = \frac{Cv^2}{2} = \frac{1}{2} (2 \times 10^{-4}) (100)^2 = \underline{1 \text{ J}}$$

$$v_c(0^+) = v_c(0^-) = \underline{100 \text{ V}}$$

Ex. 7.4-2

- a) $w(t) = w(0) + \int_0^t v i dt$
 First, $w(0) = 0$ since $v(0) = 0$
 Next, $v(t) = v(0) + \frac{1}{C} \int_0^t i dt = 10^4 \int_0^t 2 dt = 2 \times 10^4 t$
 $\therefore w(t) = \int_0^t (2 \times 10^4) t (2) dt = 2 \times 10^4 t^2$
 $w(1s) = 2 \times 10^4 J = \underline{20 \text{ kJ}}$
- b) $w(100s) = 2 \times 10^4 (100)^2 = 2 \times 10^8 J = \underline{200 \text{ MJ}}$

Ex. 7.4-3

We have $v(0^+) = v(0^-) = 3 \text{ V}$
 $v_c(t) = \frac{1}{C} \int_0^t i(t) dt + v_c(0) = 5 \int_0^t 3 e^{5t} dt + 3 = 3(e^{5t} - 1) + 3 = 3 e^{5t} \text{ V}, 0 < t < 1$

- a) $v(t) = v_R(t) + v_c(t) = 5 i(t) + v_c(t) = 15 e^{5t} + 3 e^{5t} = \underline{18 e^{5t} \text{ V}}, 0 < t < 1$
- b) $w(t) = \frac{1}{2} C v_c^2(t) = \frac{1}{2} \times 0.2 (3 e^{5t})^2 = 0.9 e^{10t} \text{ J} \Rightarrow \begin{cases} w(t)|_{t=0.2s} = \underline{6.65 \text{ J}} \\ w(t)|_{t=0.8s} = \underline{2.68 \text{ kJ}} \end{cases}$

Ex. 7.5-1

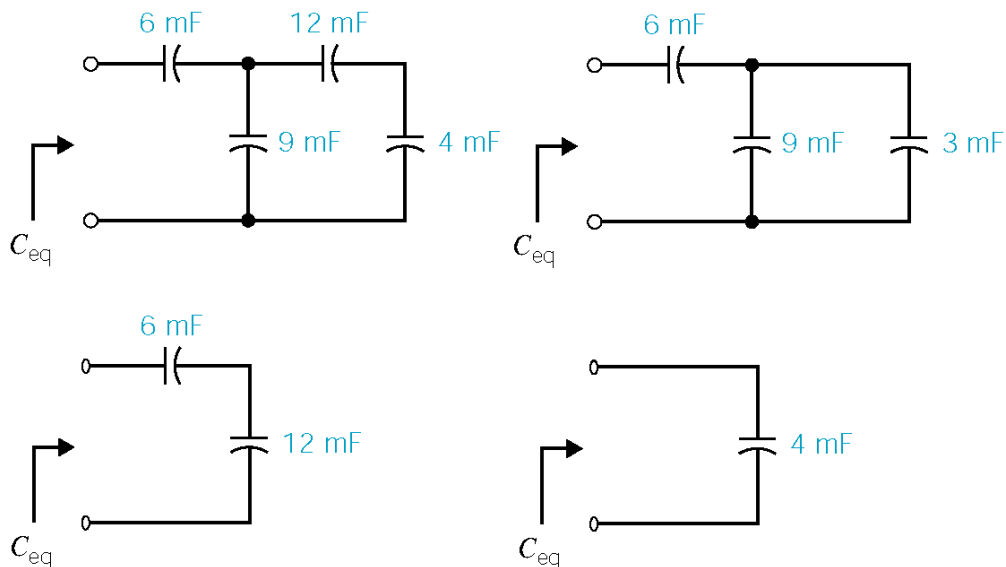

Ex. 7.5-2

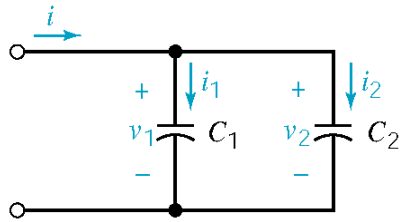

$$v_1 = v_2 \Rightarrow \frac{dv_1}{dt} = \frac{dv_2}{dt} \Rightarrow \frac{i_1}{C_1} = \frac{i_2}{C_2} \Rightarrow i_1 = \frac{C_1}{C_2} i_2$$

$$\text{KCL: } i = i_1 + i_2 = \left(\frac{C_1}{C_2} + 1 \right) i_2 \Rightarrow \underline{i_2 = \frac{C_2}{C_1 + C_2} i}$$

Ex. 7.5-3

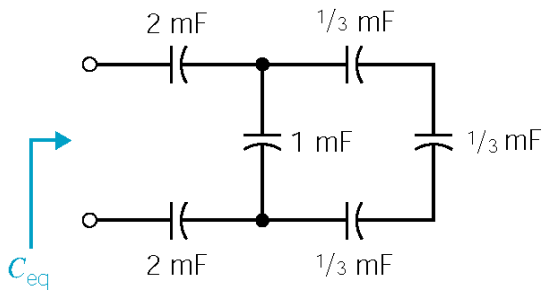

(a)

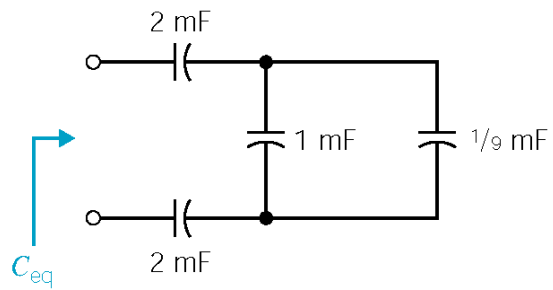

(b)

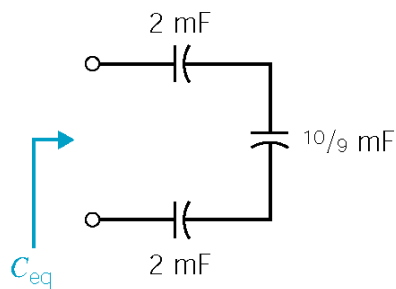

(c)

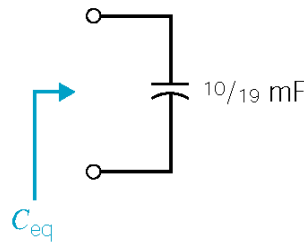

(d)

$$\text{(a) to (b): } \frac{1}{\frac{1}{3} + \frac{1}{3} + \frac{1}{3}} = \frac{1}{9} \text{ mF}, \quad \text{(b) to (c): } 1 + \frac{1}{9} = \frac{10}{9} \text{ mF},$$

$$\text{(c) to (d): } \frac{1}{C_{eq}} = \frac{1}{2} + \frac{1}{2} + \frac{1}{\frac{10}{9}} \Rightarrow \underline{C_{eq} = \frac{10}{19} \text{ mF}}$$

Ex. 7.6-1

$$v_L(t) = 1 \frac{d}{dt} i_s(t) = \begin{cases} 2 & 2 < t < 4 \\ -1 & 4 < t < 8 \\ 0 & \text{otherwise} \end{cases} \quad \text{and} \quad v_R(t) = 1 i_s(t) = \begin{cases} 2t-4 & 2 < t < 4 \\ 8-t & 4 < t < 8 \\ 0 & \text{otherwise} \end{cases}$$

$$\text{so } v(t) = v_L(t) + v_R(t) = \begin{cases} 2t-2 & 2 < t < 4 \\ 7-t & 4 < t < 8 \\ 0 & \text{otherwise} \end{cases}$$

Ex. 7.6-2

$$i(t) = \frac{1}{L} \int_{t_0}^t v_s(\tau) d\tau + i(t_0) = \frac{1}{\frac{1}{3}} \int_0^t v_s(\tau) d\tau - 12$$

$$i(t) = 3 \int_0^t 4 d\tau - 12 = 12t - 12 \quad \text{for } 0 < t < 4 \quad \text{In particular, } i(4) = 36 \text{ A.}$$

$$i(t) = 3 \int_4^t (-2) d\tau + 36 = 60 - 6t \quad \text{for } 4 < t < 10 \quad \text{In particular, } i(10) = 0 \text{ A.}$$

$$i(t) = 3 \int_{10}^t 0 d\tau + 0 = 0 \quad \text{for } 10 < t$$

Ex. 7.7-1

$$v = L \frac{di}{dt} = \left(\frac{1}{4} \right) \frac{d}{dt} (4t e^{-t}) = \underline{(1-t) e^{-t} \text{ V}}$$

$$P = vi = \left[(1-t) e^{-t} \right] (4t e^{-t}) = \underline{4t(1-t) e^{-2t} \text{ W}}$$

$$w = \frac{1}{2} Li^2 = \frac{1}{2} \left(\frac{1}{4} \right) (4t e^{-t})^2 = \underline{2t^2 e^{-2t} \text{ J}}$$

Ex. 7.7-2

$$v(t) = L \frac{di}{dt} = \frac{1}{2} \frac{di}{dt} \quad \text{and} \quad i(t) = \begin{cases} 0 & t < 0 \\ 2t & 0 < t < 1 \\ -2(t-2) & 1 < t < 2 \\ 0 & t > 2 \end{cases} \Rightarrow v(t) = \begin{cases} 0 & t < 0 \\ 1 & 0 < t < 1 \\ -1 & 1 < t < 2 \\ 0 & t > 2 \end{cases}$$

$$p(t) = v(t)i(t) = \begin{cases} 0 & t < 0 \\ 2t & 0 < t < 1 \\ 2(t-2) & 1 < t < 2 \\ 0 & t > 2 \end{cases}$$

$$\mathcal{W}(t) = \mathcal{W}(t_0) + \int_{t_0}^t p(t) dt$$

$$i(t) = 0 \text{ for } t < 0 \Rightarrow p(t) = 0 \text{ for } t < 0 \Rightarrow \mathcal{W}(t_0) = 0$$

$$0 < t < 1: \mathcal{W}(t) = \int_0^t 2t dt = t^2$$

$$1 < t < 2: \mathcal{W}(t) = \mathcal{W}(1) + \int_1^t 2(t-2) dt = t^2 - 4t + 4$$

$$t > 2: \mathcal{W}(t) = \mathcal{W}(2) = 0$$

Ex. 7.8-1

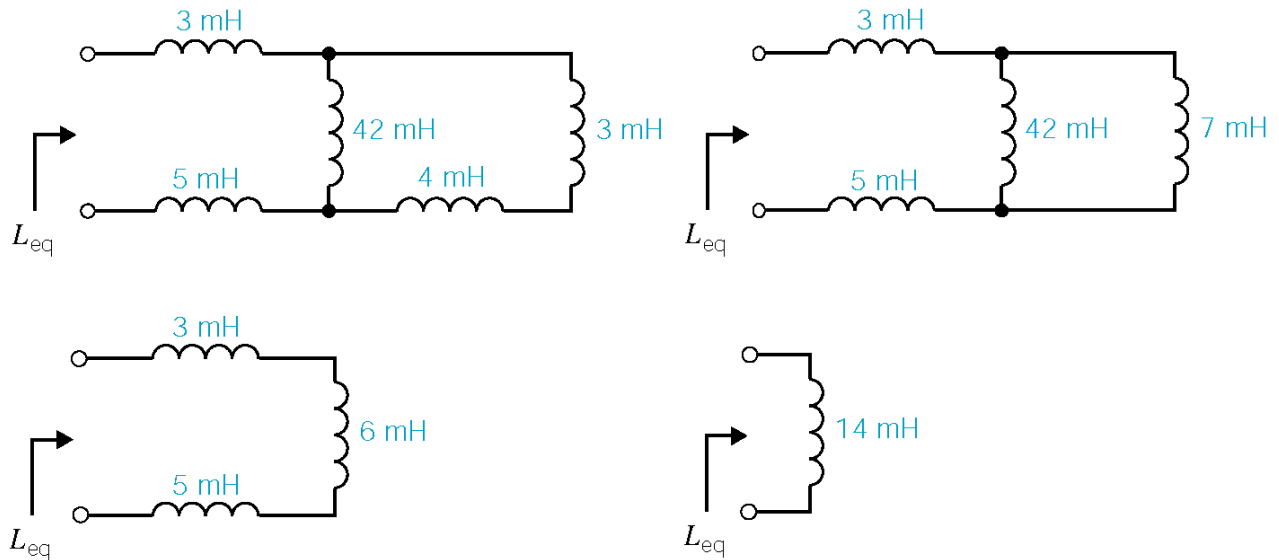

Ex. 7.8-2

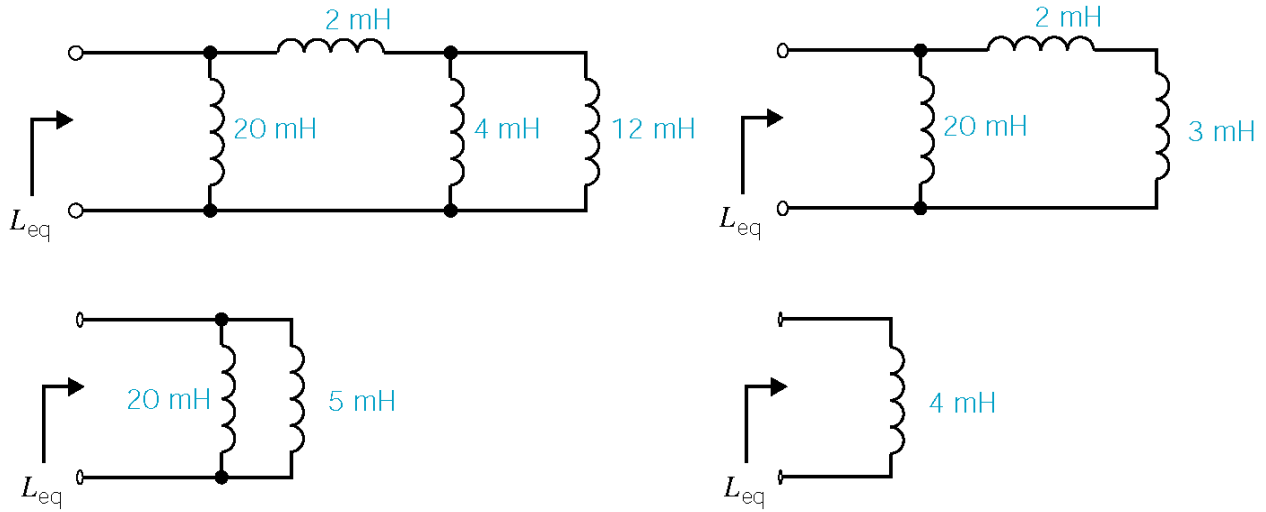

Ex. 7.8-3

$$i_1 = \frac{1}{L_1} \int_{t_0}^t v dt + i_1(t_0), \quad i_2 = \frac{1}{L_2} \int_{t_0}^t v dt + i_2(t_0) \quad \text{but } i_1(t_0) = 0 \text{ and } i_2(t_0) = 0$$

$$i = i_1 + i_2 = \frac{1}{L_1} \int_{t_0}^t v dt + \int_{t_0}^t v dt = \left(\frac{1}{L_1} + \frac{1}{L_2} \right) \int_{t_0}^t v dt = \frac{1}{L_p} \int_{t_0}^t v dt$$

$$\therefore \frac{i_1}{i} = \frac{\frac{1}{L_1} \int_{t_0}^t v dt}{\frac{1}{L_p} \int_{t_0}^t v dt} = \frac{\frac{1}{L_1}}{\frac{1}{L_1} + \frac{1}{L_2}} = \frac{L_2}{L_1 + L_2}$$

Problems

Section 7-3: Capacitors

P7.3-1

$$v(t) = v(0) + \frac{1}{C} \int_0^t i(\tau) d\tau \quad \text{and} \quad q = Cv$$

In our case, the current is constant so $\int_0^t i(\tau) d\tau$.

$$\therefore Cv(t) = Cv(0) + it$$

$$\therefore t = \frac{q - Cv(0)}{i} = \frac{150 \times 10^{-6} - (15 \times 10^{-6})(5)}{25 \times 10^{-3}} = \underline{3 \text{ ms}}$$

P7.3-2

$$i(t) = C \frac{d}{dt} v(t) = \frac{1}{8} \frac{d}{dt} 12 \cos(2t + 30^\circ) = \frac{1}{8} (12)(-2) \sin(2t + 30^\circ) = 3 \cos(2t + 120^\circ) \text{ A}$$

P7.3-3

$$\begin{aligned} (3 \times 10^{-3}) \cos(500t + 45^\circ) &= C \frac{d}{dt} 12 \cos(500t - 45^\circ) = C(12)(-500) \sin(500t - 45^\circ) \\ &= C(6000) \cos(500t + 45^\circ) \end{aligned}$$

so

$$C = \frac{3 \times 10^{-3}}{6 \times 10^3} = \frac{1}{2} \times 10^{-6} = \frac{1}{2} \mu\text{F}$$

P7.3-4

$$v(t) = \frac{1}{C} \int_0^t i(\tau) d\tau + v(0) = \frac{1}{2 \times 10^{-12}} \int_0^t i(\tau) d\tau - 10^{-3}$$

$$0 < t < 2 \times 10^{-9} \quad i_s(t) = 0 \Rightarrow v(t) = \frac{1}{2 \times 10^{-12}} \int_0^t 0 d\tau - 10^{-3} = -10^{-3}$$

$$2 \times 10^{-9} < t < 3 \times 10^{-9} \quad i_s(t) = 4 \times 10^{-6} \text{ A}$$

$$\Rightarrow v(t) = \frac{1}{2 \times 10^{-12}} \int_{2 \text{ ns}}^t (4 \times 10^{-6}) d\tau - 10^{-3} = -5 \times 10^{-3} + (2 \times 10^6) t$$

$$\text{In particular, } v(3 \times 10^{-9}) = -5 \times 10^{-3} + (2 \times 10^6)(3 \times 10^{-9}) = 10^{-3}$$

$$3 \times 10^{-9} < t < 5 \times 10^{-9} \quad i_s(t) = -2 \times 10^{-6} \text{ A}$$

$$\Rightarrow v(t) = \frac{1}{2 \times 10^{-12}} \int_{3 \text{ ns}}^t (-2 \times 10^{-6}) d\tau + 10^{-3} = 4 \times 10^{-3} - (10^6) t$$

$$\text{In particular, } v(5 \times 10^{-9}) = 4 \times 10^{-3} - (10^6)(5 \times 10^{-9}) = -10^{-3} \text{ V}$$

$$5 \times 10^{-9} < t \quad i_s(t) = 0 \Rightarrow v(t) = \frac{1}{2 \times 10^{-12}} \int_{5 \text{ ns}}^t 0 d\tau - 10^{-3} = -10^{-3} \text{ V}$$

P7.3-5

$$(b) \quad i(t) = C \frac{d}{dt} v(t) = \begin{cases} 0 & 0 < t < 1 \\ 4 & 1 < t < 2 \\ -4 & 2 < t < 3 \\ 0 & 3 < t \end{cases}$$

$$(a) \quad v(t) = \frac{1}{C} \int_0^t i(\tau) d\tau + v(0) = \int_0^t i(\tau) d\tau$$

$$\text{For } 0 < t < 1, i(t) = 0 \text{ A so } v(t) = \int_0^t 0 d\tau + 0 = 0 \text{ V}$$

$$\text{For } 1 < t < 2, i(t) = (4t - 4) \text{ A so}$$

$$v(t) = \int_1^t (4\tau - 4) d\tau + 0 = (2\tau^2 - 4\tau) \Big|_1^t = 2t^2 - 4t + 2 \text{ V}$$

$$v(2) = 2(2^2) - 4(2) + 2 = 2 \text{ V. For } 2 < t < 3, i(t) = (-4t + 12) \text{ A so}$$

$$v(t) = \int_2^t (-4\tau + 12) d\tau + 2 = (-2\tau^2 + 12\tau) \Big|_2^t + 2 = (-2t^2 + 12t - 14) \text{ V}$$

$$v(3) = -2(3^2) + 12(3) - 14 = 4 \text{ V}$$

$$\text{For } 3 < t, i(t) = 0 \text{ A so } v(t) = \int_0^t 0 d\tau + 4 = 4 \text{ V}$$

P7.3-6

(a)
$$i(t) = C \frac{d}{dt} v(t) = \begin{cases} 0 & 0 < t < 2 \\ 0.1 & 2 < t < 6 \\ 0 & 6 < t \end{cases}$$

(b)
$$v(t) = \frac{1}{C} \int_0^t i(\tau) d\tau + v(0) = 2 \int_0^t i(\tau) d\tau$$

For $0 < t < 2$, $i(t) = 0$ A so $v(t) = 2 \int_0^t 0 d\tau + 0 = 0$ V

For $2 < t < 6$, $i(t) = 0.2 t - 0.4$ V so

$$v(t) = 2 \int_1^t (0.2\tau - 0.4) d\tau + 0 = (0.2\tau^2 - 0.8\tau) \Big|_2^t = 0.2t^2 - 0.8t + 0.8$$
 V

$v(6) = 0.2(6^2) - 0.8(6) + 0.8 = 3.2$ V. For $6 < t$, $i(t) = 0.8$ A so

$$v(t) = 2 \int_6^t 0.8 d\tau + 3.2 = 1.6t - 6.4$$
 V

P7.3-7

$$\begin{aligned} v(t) &= v(0) + \frac{1}{C} \int_0^t i(\tau) d\tau = 25 + 2.5 \times 10^4 \int_0^t (6 \times 10^{-3}) e^{-6\tau} d\tau \\ &= 25 + 150 \int_0^t e^{-6\tau} d\tau \\ &= 25 + 150 \left[-\frac{1}{6} e^{-6\tau} \right]_0^t = \underline{50 - 25e^{-6t}} \text{ V} \end{aligned}$$

P7.3-8

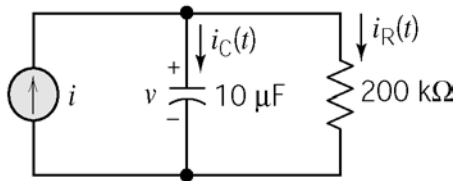

$$i_R = \frac{v}{200 \times 10^3} = \frac{1}{40} (1 - 2e^{-2t}) \times 10^{-3} = 25(1 - 2e^{-2t}) \mu\text{A}$$

$$i_C = C \frac{dv}{dt} = (10 \times 10^{-6}) (-2) (-10 e^{-2t}) = 200 e^{-2t} \mu\text{A}$$

$$\begin{aligned} i &= i_R + i_C = 200 e^{-2t} + 25 - 50 e^{-2t} \\ &= \underline{25 + 150 e^{-2t}} \mu\text{A} \end{aligned}$$

Section 7-4: Energy Storage in a Capacitor

P7.4-1

Given

$$i(t) = \begin{cases} 0 & t < 2 \\ 0.2(t-2) & 2 < t < 6 \\ 0.8 & t > 6 \end{cases}$$

The capacitor voltage is given by

$$v(t) = \frac{1}{0.5} \int_0^t i(\tau) d\tau + v(0) = 2 \int_0^t i(\tau) d\tau + v(0)$$

For $t < 2$

$$v(t) = 2 \int_0^t 0 d\tau + 0 = 0$$

In particular, $v(2) = 0$. For $2 < t < 6$

$$v(t) = 2 \int_2^t 2(\tau-2) d\tau + 0 = (0.2\tau^2 - 0.8\tau) \Big|_2^t = (0.2t^2 - 0.8t + 0.8) \text{ V} = 0.2(t^2 - 4t + 4) \text{ V}$$

In particular, $v(6) = 3.2 \text{ V}$. For $6 < t$

$$v(t) = 2 \int_6^t 0.8 d\tau + 3.2 = 1.6\tau \Big|_6^t + 3.2 = (1.6t - 6.4) \text{ V} = 1.6(t-4) \text{ V}$$

Now the power and energy are calculated as

$$p(t) = v(t)i(t) = \begin{cases} 0 & t < 2 \\ 0.04(t-2)^2 & 2 < t < 6 \\ 1.28(t-4) & 6 < t \end{cases}$$

and

$$w(t) = \int_0^t p(\tau) d\tau = \begin{cases} 0 & t < 2 \\ 0.01(t-2)^4 & 2 < t < 6 \\ 0.8(t-4)^2 - 0.64 & 6 < t \end{cases}$$

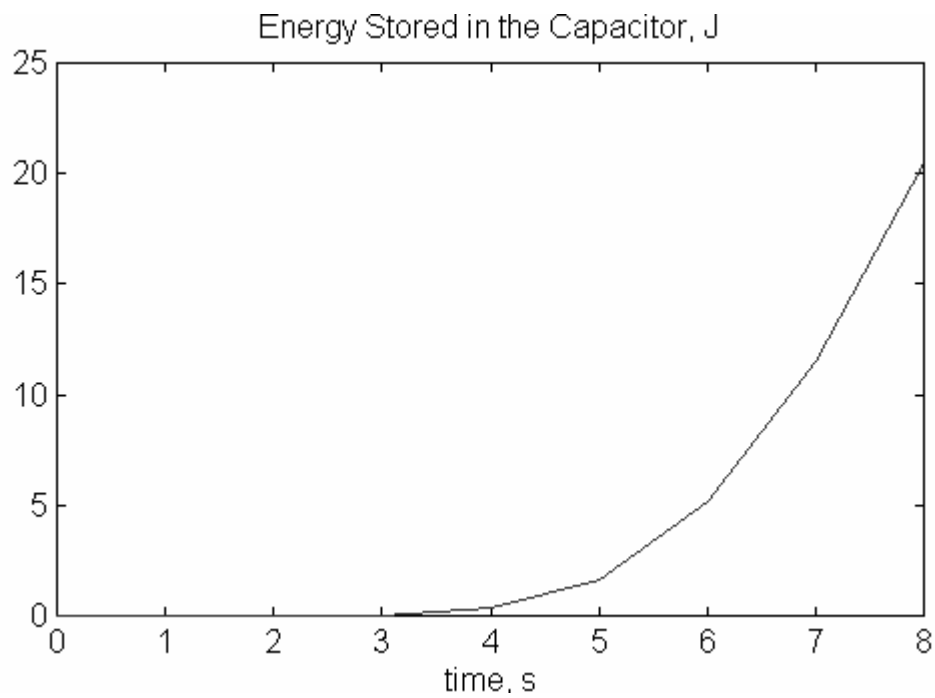
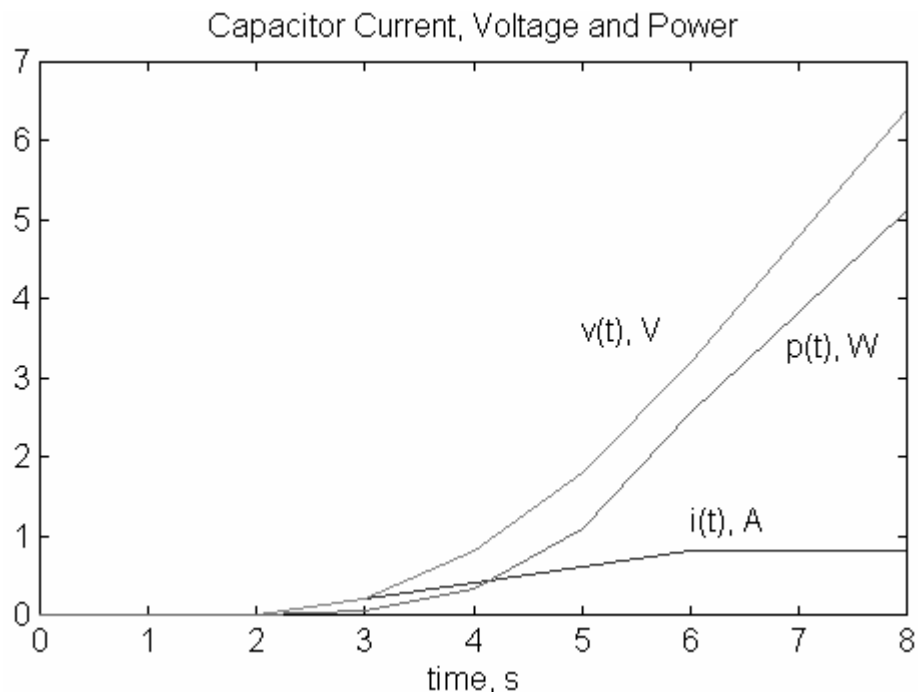

These plots were produced using three MATLAB scripts:

```
capvol.m      function v = CapVol(t)
              if t<2
                v = 0;
              elseif t<6
                v = 0.2*t*t - .8*t + .8;
              else
                v = 1.6*t - 6.4;
              end

capcur.m      function i = CapCur(t)
              if t<2
                i=0;
              elseif t<6
                i=.2*t - .4;
              else
                i =.8;
              end

c7s4p1.m     t=0:1:8;
              for k=1:1:length(t)
                i(k)=CapCur(k-1);
                v(k)=CapVol(k-1);
                p(k)=i(k)*v(k);
                w(k)=0.5*v(k)*v(k);
              end

              plot(t,i,t,v,t,p)
              text(5,3.6,'v(t), V')
              text(6,1.2,'i(t), A')
              text(6.9,3.4,'p(t), W')
              title('Capacitor Current, Voltage and Power')
              xlabel('time, s')

              % plot(t,w)
              % title('Energy Stored in the Capacitor, J')
              % xlabel('time, s')
```

P7.4-2

$$i_c = C \frac{dv}{dt} = (10 \times 10^{-6})(-5)(-4000)e^{-4000t} = \underline{0.2e^{-4000t} \text{ A}} \Rightarrow \begin{cases} i_c(0) = 0.2 \text{ A} \\ i_c(10\text{ms}) = 8.5 \times 10^{-19} \text{ A} \end{cases}$$

$$w(t) = \frac{1}{2} C v^2(t) \quad \text{and} \quad v(0) = 5 - 5e^0 = 0 \Rightarrow \underline{w(0) = 0}$$

$$v(10 \times 10^{-3}) = 5 - 5e^{-40} = 5 - 21.2 \times 10^{-18} \cong 5 \Rightarrow \underline{w(10) = 1.25 \times 10^{-4} \text{ J}}$$

P7.4-3

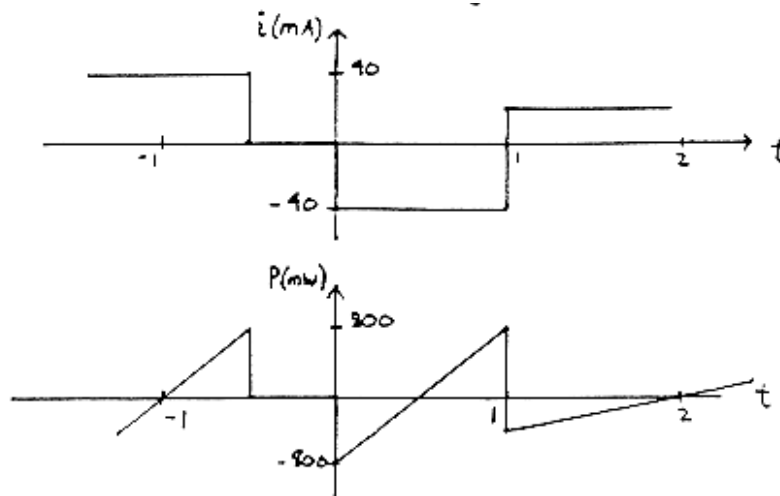

$$i(t) = C \frac{dv_c}{dt} \text{ so read off slope of } v_c(t) \text{ to get } i(t)$$

$$p(t) = v_c(t) i(t) \text{ so multiply } v_c(t) \text{ \& } i(t) \text{ curves to get } p(t)$$

P7.4-4

$$v_c(t) = v_c(0) + \frac{1}{C} \int_0^t i \, d\tau = v_c(0) + \frac{1}{2} \int_0^t 50 \cos\left(10\tau + \frac{\pi}{6}\right) d\tau = \left[v_c(0) - \frac{5}{2} \sin\frac{\pi}{6} \right] + \frac{5}{2} \sin\left(10t + \frac{\pi}{6}\right)$$

$$\text{Now since } v_c(t)_{ave} = 0 \Rightarrow v_c(0) - \frac{5}{2} \sin\frac{\pi}{6} = 0 \Rightarrow v_c(t) = \frac{5}{2} \sin\left(10t + \frac{\pi}{6}\right) \text{ V}$$

$$\therefore w_{\max} = \frac{1}{2} C v_{c_{\max}}^2 = \frac{(2 \times 10^{-6})(2.5)^2}{2} = \underline{6.25 \mu\text{J}}$$

$$\text{First non-negative } t \text{ for max energy occurs when: } 10t + \frac{\pi}{6} = \frac{\pi}{2} \Rightarrow t = \underline{\underline{\frac{\pi}{30} = 0.1047 \text{ s}}}$$

P7.4-5

$$\text{Max. charge on capacitor} = C v = (10 \times 10^{-6}) (6) = 60 \mu\text{C}$$

$$\Delta t = \frac{\Delta q}{i} = \frac{60 \times 10^{-6}}{10 \times 10^{-6}} = \underline{6 \text{ sec to charge}}$$

$$\text{stored energy} = \mathcal{W} = \frac{1}{2} C v^2 = \frac{1}{2} (10 \times 10^{-6}) (6)^2 = \underline{180 \mu\text{J}}$$

Section 7-5: Series and Parallel capacitors**P7.5-1**

$$2 \mu\text{F} \parallel 4 \mu\text{F} = 6 \mu\text{F}$$

$$6 \mu\text{F} \text{ in series with } 3 \mu\text{F} = \frac{6 \mu\text{F} \cdot 3 \mu\text{F}}{6 \mu\text{F} + 3 \mu\text{F}} = 2 \mu\text{F}$$

$$i(t) = 2 \mu\text{F} \frac{d}{dt} (6 \cos 100t) = (2 \times 10^{-6}) (6) (100) (-\sin 100t) \text{ A} = \underline{-1.2 \sin 100t \text{ mA}}$$

P7.5-2

$$4 \mu\text{F} \text{ in series with } 4 \mu\text{F} = \frac{4 \mu\text{F} \times 4 \mu\text{F}}{4 \mu\text{F} + 4 \mu\text{F}} = 2 \mu\text{F}$$

$$2 \mu\text{F} \parallel 2 \mu\text{F} = 4 \mu\text{F}$$

$$4 \mu\text{F} \text{ in series with } 4 \mu\text{F} = 2 \mu\text{F}$$

$$i(t) = (2 \times 10^{-6}) \frac{d}{dt} (5 + 3 e^{-250t}) = (2 \times 10^{-6}) (0 + 3(-250) e^{-250t}) \text{ A} = \underline{-1.5 e^{-250t} \text{ mA}}$$

P7.5-3

$$C \text{ in series with } C = \frac{C \cdot C}{C + C} = \frac{C}{2}$$

$$C \parallel C \parallel \frac{C}{2} = \frac{5}{2} C$$

$$C \text{ in series with } \frac{5}{2} C = \frac{C \cdot \frac{5}{2} C}{C + \frac{5}{2} C} = \frac{5}{7} C$$

$$(25 \times 10^{-3}) \cos 250t = \left(\frac{5}{7} C \right) \frac{d}{dt} (14 \sin 250t) = \left(\frac{5}{7} C \right) (14)(250) \cos 250t$$

$$\text{so } 25 \times 10^{-3} = 2500 C \Rightarrow C = 10 \times 10^{-6} = 10 \mu\text{F}$$

Section 7-6: Inductors

P7.6-1

Find max. voltage across coil: $v(t) = L \frac{di}{dt} = 200 [100(400) \cos 400t] \text{ V}$

$\therefore v_{\max} = 8 \times 10^6 \text{ V}$ thus have a field of $\frac{8 \times 10^6}{2} \text{ V/m} = 4 \times 10^6 \text{ V/m}$

which exceeds dielectric strength in air of $3 \times 10^6 \text{ V/m}$

\therefore We get a discharge as the air is ionized.

P7.6-2

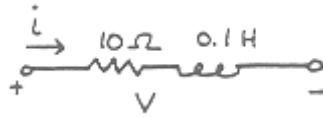

$$v = L \frac{di}{dt} + R i = (.1) (4e^{-t} - 4te^{-t}) + 10(4te^{-t}) = \underline{0.4e^{-t} + 39.6te^{-t} \text{ V}}$$

P7.6-3

$$(a) \quad v(t) = L \frac{d}{dt} i(t) = \begin{cases} 0 & 0 < t < 1 \\ 4 & 1 < t < 2 \\ -4 & 2 < t < 3 \\ 0 & 3 < t \end{cases}$$

$$(b) \quad i(t) = \frac{1}{L} \int_0^t v(\tau) d\tau + i(0) = \int_0^t v(\tau) d\tau$$

For $0 < t < 1$, $v(t) = 0 \text{ V}$ so $i(t) = \int_0^t 0 d\tau + 0 = 0 \text{ A}$

For $1 < t < 2$, $v(t) = (4t - 4) \text{ V}$ so

$$i(t) = \int_0^t (4\tau - 4) d\tau + 0 = (2\tau^2 - 4\tau) \Big|_1^t = 2t^2 - 4t + 2 \text{ A}$$

$$i(2) = 4(2^2) - 4(2) + 2 = 2 \text{ A}$$

For $2 < t < 3$, $v(t) = -4t + 12 \text{ V}$ so

$$i(t) = \int_2^t (-4\tau + 12) d\tau + 2 = (-2\tau^2 + 12\tau) \Big|_2^t + 2 = (-2t^2 + 12t - 14) \text{ A}$$

$$i(3) = -2(3^2) + 12(3) - 14 = 4 \text{ A}$$

For $3 < t$, $v(t) = 0 \text{ V}$ so $i(t) = \int_3^t 0 d\tau + 4 = 4 \text{ A}$

P7.6-4

$$v(t) = (250 \times 10^{-3}) \frac{d}{dt} (120 \times 10^{-3}) \sin(500t - 30^\circ) = (0.25)(0.12)(500) \cos(500t - 30^\circ)$$

$$= 15 \cos(500t - 30^\circ)$$

P7.6-5

$$i_L(t) = \frac{1}{5 \times 10^{-3}} \int_0^t v_s(\tau) d\tau - 2 \times 10^{-6}$$

for $0 < t < 1 \mu\text{s}$ $v_s(t) = 4 \text{ mV}$

$$i_L(t) = \frac{1}{5 \times 10^{-3}} \int_0^t 4 \times 10^{-3} d\tau - 2 \times 10^{-6} = \left(\frac{4 \times 10^{-3}}{5 \times 10^{-3}} \right) t - 2 \times 10^{-6} = 0.8t - 2 \times 10^{-6} \text{ A}$$

$$i_L(1 \mu\text{s}) = \left(\frac{4 \times 10^{-3}}{5 \times 10^{-3}} (1 \times 10^{-6}) \right) - 2 \times 10^{-6} = -\frac{6}{5} \times 10^{-6} \text{ A} = -1.2 \text{ A}$$

for $1 \mu\text{s} < t < 3 \mu\text{s}$ $v_s(t) = -1 \text{ mV}$

$$i_L(t) = \frac{1}{5 \times 10^{-3}} \int_{1 \mu\text{s}}^t (-1 \times 10^{-3}) d\tau - \frac{6}{5} \times 10^{-6} = -\frac{1 \times 10^{-3}}{5 \times 10^{-3}} (t - 1 \times 10^{-6}) - \frac{6}{5} \times 10^{-6} = (-0.2t - 10^{-6}) \text{ A}$$

$$i_L(3 \mu\text{s}) = \left(-\frac{1 \times 10^{-3}}{5 \times 10^{-3}} + 3 \times 10^{-6} \right) - 1 \times 10^{-6} = -1.6 \mu\text{A}$$

for $3 \mu\text{s} < t$ $v_s(t) = 0$ so $i_L(t)$ remains $-1.6 \mu\text{A}$

P7.6-6

$$v(t) = (2 \times 10^3) i_s(t) + (4 \times 10^{-3}) \frac{d}{dt} i_s(t) \quad (\text{in general})$$

$$\text{for } 0 < t < 1 \mu\text{s} \quad i_s(t) = (1) \left(\frac{1 \times 10^{-3}}{1 \times 10^{-6}} \right) t = 10^3 t \Rightarrow \frac{d}{dt} i_s(t) = 1 \times 10^3$$

$$v(t) = (2 \times 10^3)(1 \times 10^3) t + 4 \times 10^{-3}(1 \times 10^3) = (2 \times 10^6 t + 4) \text{ V}$$

$$\text{for } 1 \mu\text{s} < t < 3 \mu\text{s} \quad i_s(t) = 1 \text{ mA} \Rightarrow \frac{d}{dt} i_s(t) = 0$$

$$v(t) = (2 \times 10^3)(1 \times 10^{-3}) + (4 \times 10^{-3}) \times 0 = 2 \text{ V}$$

$$\text{for } 3 \mu\text{s} < t < 5 \mu\text{s} \quad i_s(t) = 4 \times 10^{-3} - \left(\frac{1 \times 10^{-3}}{1 \times 10^{-6}} \right) t \Rightarrow \frac{d}{dt} i_s(t) = -\frac{1 \times 10^{-3}}{1 \times 10^{-6}} = -10^3$$

$$v(t) = (2 \times 10^3)(4 \times 10^{-3} - 10^3 t) + 4 \times 10^{-3}(-10^3) = 4 - (2 \times 10^6) t$$

$$\text{when } 5 \mu\text{s} < t < 7 \mu\text{s} \quad i_s(t) = -1 \times 10^{-3} \text{ and } \frac{d}{dt} i_s(t) = 0$$

$$v(t) = (2 \times 10^3)(10^{-3}) = -2 \text{ V}$$

$$\text{when } 7 \mu\text{s} < t < 8 \mu\text{s} \quad i_s(t) = \left(\frac{1 \times 10^{-3}}{1 \times 10^{-6}} \right) t - 8 \times 10^{-3} \Rightarrow \frac{d}{dt} i_s(t) = 1 \times 10^3$$

$$v(t) = (2 \times 10^3)(10^3 t - 8 \times 10^{-3}) + (4 \times 10^{-3})(10^3) = -12 + (2 \times 10^6) t$$

$$\text{when } 8 \mu\text{s} < t, \text{ then } i_s(t) = 0 \Rightarrow \frac{d}{dt} i_s(t) = 0$$

$$v(t) = 0$$

P7.6-8

$$(a) \quad v(t) = L \frac{d}{dt} i(t) = \begin{cases} 0 & 0 < t < 2 \\ 0.1 & 2 < t < 6 \\ 0 & 6 < t \end{cases}$$

$$(b) \quad i(t) = \frac{1}{L} \int_0^t v(\tau) d\tau + i(0) = 2 \int_0^t v(\tau) d\tau$$

$$\text{For } 0 < t < 2, v(t) = 0 \text{ V so } i(t) = 2 \int_0^t 0 d\tau + 0 = 0 \text{ A}$$

$$\text{For } 2 < t < 6, v(t) = 0.2 t - 0.4 \text{ V so}$$

$$i(t) = 2 \int_2^t (0.2\tau - 0.4) d\tau + 0 = (0.2\tau^2 - 0.8\tau) \Big|_2^t = 0.2t^2 - 0.8t + 0.8 \text{ A}$$

$$i(6) = 0.2(6^2) - 0.8(6) + 0.8 = 3.2 \text{ A.}$$

$$\text{For } 6 < t, v(t) = 0.8 \text{ V so}$$

$$i(t) = 2 \int_6^t 0.8 \, d\tau + 3.2 = (1.6t - 6.4) \text{ A}$$

Section 7-7: Energy Storage in an Inductor

P7.7-1

$$v(t) = 100 \times 10^{-3} \frac{d}{dt} i(t) = \begin{cases} 0 & t < 0 \\ 0.4 & 0 \leq t \leq 1 \\ 0 & t > 1 \end{cases}$$

$$p(t) = v(t)i(t) = \begin{cases} 0 & t < 0 \\ 1.6t & 0 \leq t \leq 1 \\ 0 & t > 1 \end{cases}$$

$$w(t) = \int_0^t p(\tau) \, d\tau = \begin{cases} 0 & t < 0 \\ 0.8t^2 & 0 < t < 1 \\ 0.8 & t > 1 \end{cases}$$

P7.7-2

$$\begin{aligned}
p(t) &= v(t) i(t) = \left[5 \frac{d}{dt} (4 \sin 2t) \right] (4 \sin 2t) \\
&= 5 (8 \cos 2t) (4 \sin 2t) \\
&= 80 [2 \cos 2t \sin 2t] \\
&= 80 [\sin(2t+2t) + \sin(2t-2t)] = 80 \sin 4t \text{ W} \\
\mathcal{W}(t) &= \int_0^t p(\tau) d\tau = 80 \int_0^t \sin 4\tau d\tau = -\frac{80}{4} [\cos 4\tau]_0^t = 20 (1 - \cos 4t)
\end{aligned}$$

P7.7-3

$$\begin{aligned}
i(t) &= \frac{1}{25 \times 10^{-3}} \int_0^t 6 \cos 100\tau d\tau + 0 \\
&= \frac{6}{(25 \times 10^{-3})(100)} [\sin 100\tau]_0^t = 2.4 \sin 100t \\
p(t) &= v(t) i(t) = (6 \cos 100t)(2.4 \sin 100t) \\
&= 7.2 [2(\cos 100t)(\sin 100t)] \\
&= 7.2 [\sin 200t + \sin 0] = 7.2 \sin 200t \\
\mathcal{W}(t) &= \int_0^t p(\tau) d\tau = 7.2 \int_0^t \sin 200\tau d\tau \\
&= -\frac{7.2}{200} [\cos 200\tau]_0^t \\
&= 0.036 [1 - \cos 200t] \text{ J} = 36 [1 - \cos 200t] \text{ mJ}
\end{aligned}$$

Section 7-8: Series and Parallel Inductors**P7.8-1**

$$\begin{aligned}
6 \text{ H} \parallel 3 \text{ H} &= \frac{6 \times 3}{6+3} = 2 \text{ H} \quad \text{and} \quad 2 \text{ H} + 2 \text{ H} = 4 \text{ H} \\
i(t) &= \frac{1}{4} \int_0^t 6 \cos 100\tau d\tau = \frac{6}{4 \times 100} [\sin 100\tau]_0^t = 0.015 \sin 100t \text{ A} = 15 \sin 100t \text{ mA}
\end{aligned}$$

P7.8-2

$$\begin{aligned}
4 \text{ mH} + 4 \text{ mH} &= 8 \text{ mH} \quad , \quad 8 \text{ mH} \parallel 8 \text{ mH} = \frac{(8 \times 10^{-3}) \times (8 \times 10^{-3})}{8 \times 10^{-3} + 8 \times 10^{-3}} = 4 \text{ mH} \\
\text{and} \quad 4 \text{ mH} + 4 \text{ mH} &= 8 \text{ mH} \\
v(t) &= (8 \times 10^{-3}) \frac{d}{dt} (5 + 3e^{-250t}) = (8 \times 10^{-3})(0 + 3(-250)e^{-250t}) = -6e^{-250t} \text{ V}
\end{aligned}$$

P7.8-3

$$L \parallel L = \frac{L \cdot L}{L+L} = \frac{L}{2} \quad \text{and} \quad L + L + \frac{L}{2} = \frac{5}{2} L$$
$$25 \cos 250t = \left(\frac{5}{2} L\right) \frac{d}{dt} \left((14 \times 10^{-3}) \sin 250t \right) = \left(\frac{5}{2} L\right) (14 \times 10^{-3}) (250) \cos 250t$$
$$\text{so } L = \frac{25}{\frac{5}{2} (14 \times 10^{-3}) (250)} = 2.86 \text{ H}$$

Section 7-9: Initial Conditions of Switched Circuits

P7.9-1

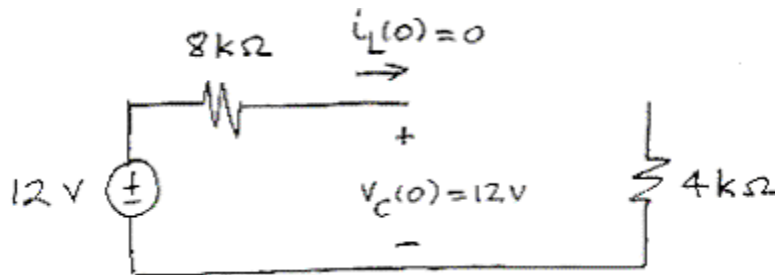

Then

$$i_L(0^+) = i_L(0^-) = 0 \quad \text{and} \quad v_C(0^+) = v_C(0^-) = 12\text{ V}$$

Next

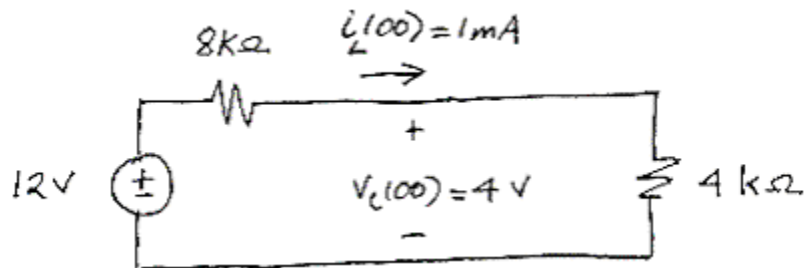

P7.9-2

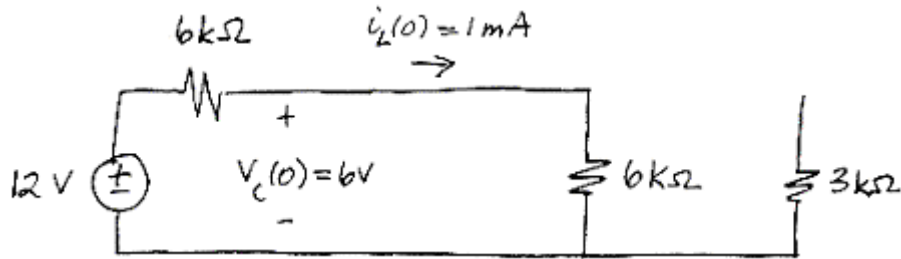

Then

$$i_L(0^+) = i_L(0^-) = 1 \text{ mA} \quad \text{and} \quad v_C(0^+) = v_C(0^-) = 6 \text{ V}$$

Next

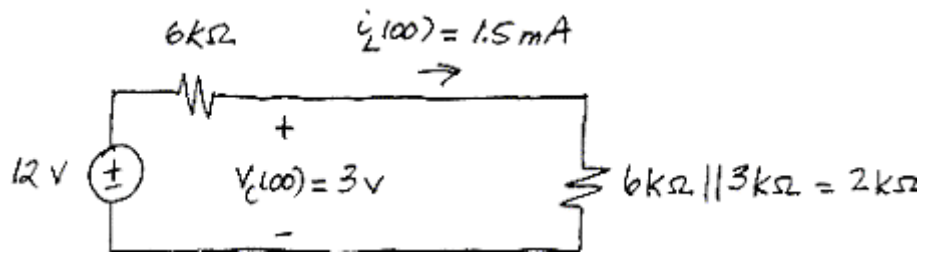

P7.9-3

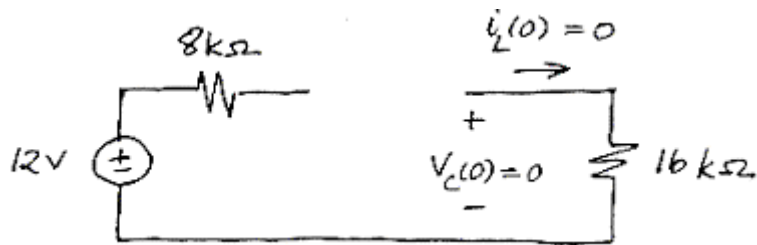

Then

$$i_L(0^+) = i_L(0^-) = 0 \quad \text{and} \quad v_C(0^+) = v_C(0^-) = 0 \text{ V}$$

Next

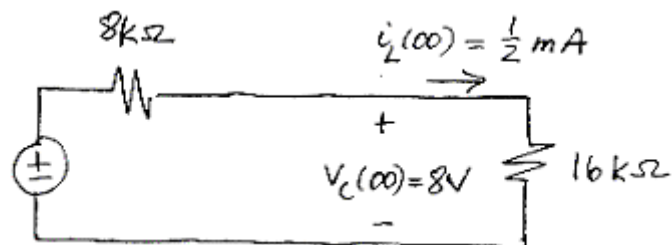

P7.9-4

at $t = 0^-$

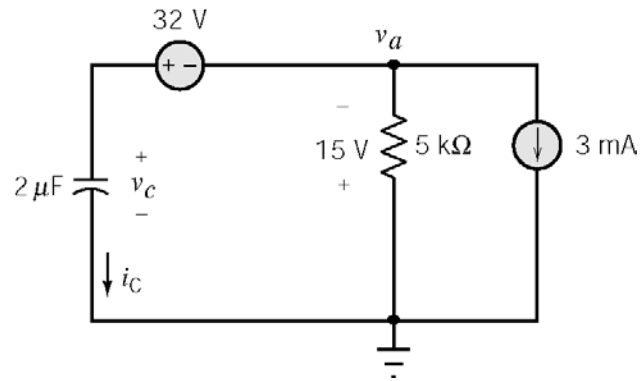

$$\text{KVL: } -v_c(0^-) + 32 - 15 = 0 \Rightarrow \underline{v_c(0^-) = v_c(0^+) = 17 \text{ V}}$$

at $t = 0^+$

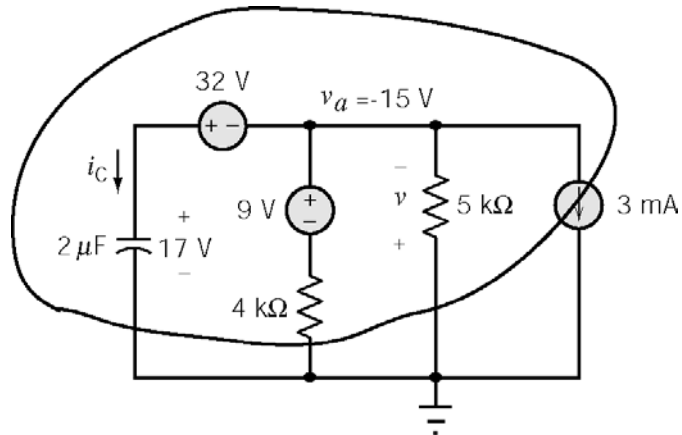

Apply KCL to supernode shown above:

$$i_c(0^+) + \frac{-15 - 9}{4000} - \frac{15}{5000} + 0.003 = 0 \Rightarrow i_c(0^+) = 6 \text{ mA}$$

Then

$$\left. \frac{dv_c}{dt} \right|_{t=0^+} = \frac{i_c(0^+)}{C} = \frac{6 \times 10^{-3}}{2 \times 10^{-6}} = 3000 \frac{\text{V}}{\text{s}}$$

Section 7-10: Operational amplifier Circuits and Linear Differential Equations

P7.10-1

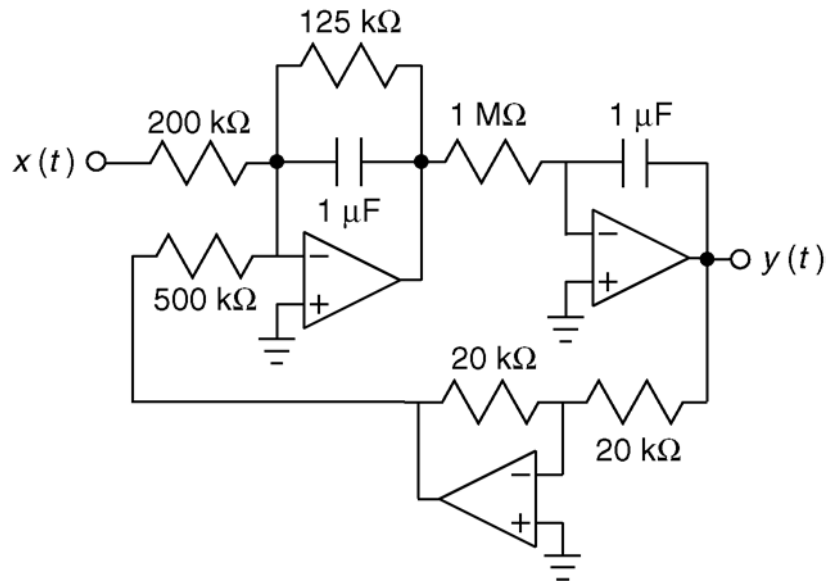

P7.10-2

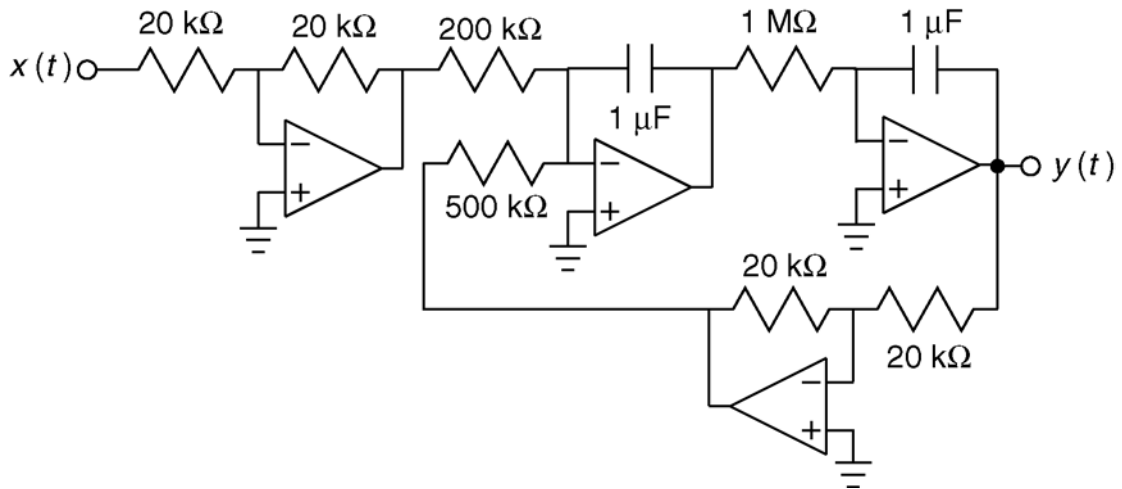

P7.10-3

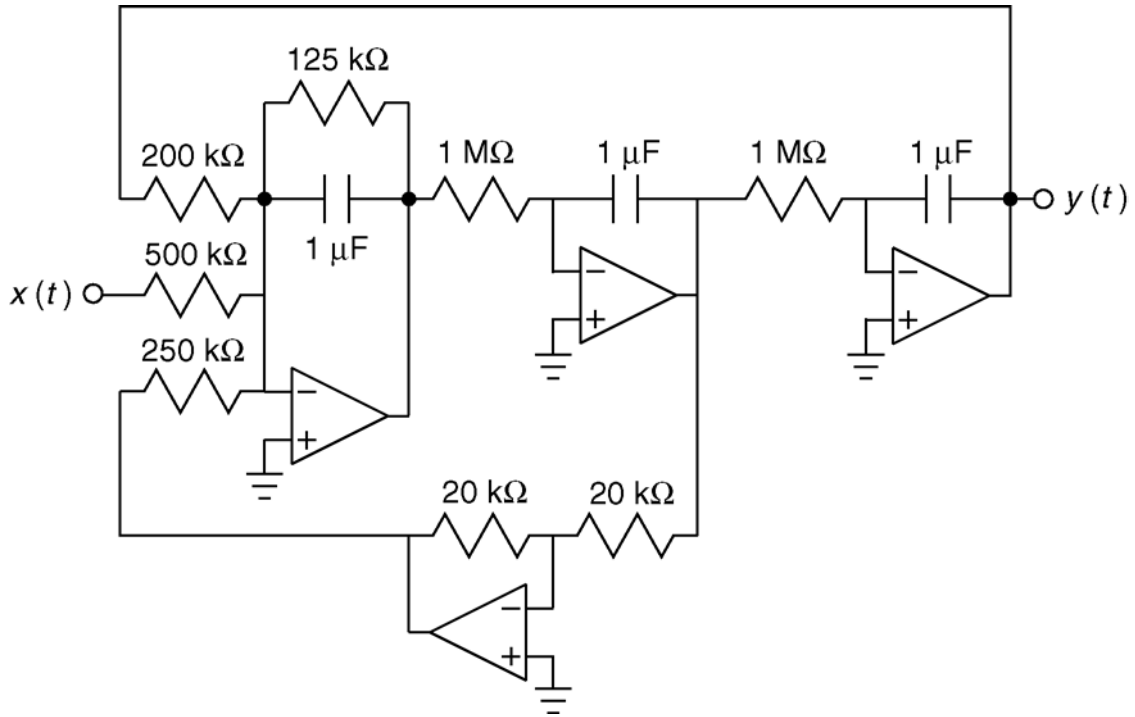

P7.10-4

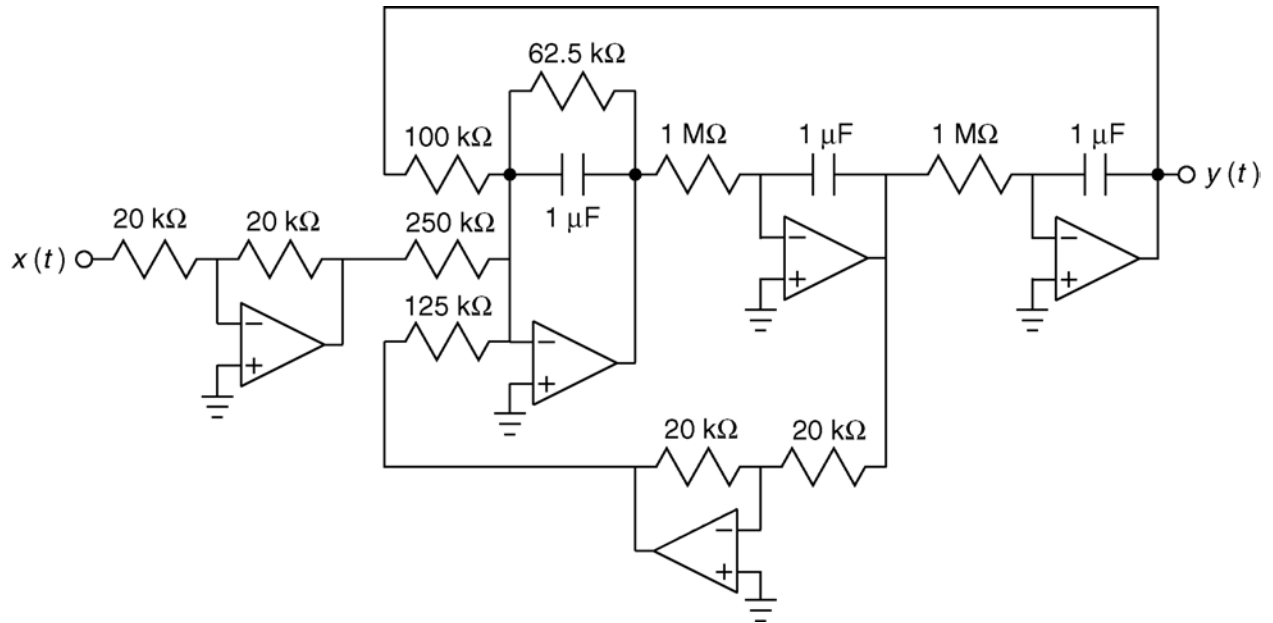

Verification Problems

VP7-1

We need to check the values of the inductor current at the ends of the intervals.

$$\text{at } t=1 \quad 0.025 \stackrel{?}{=} -\frac{1}{25} + 0.065 = 0.025 \quad (\text{Yes!})$$

$$\begin{aligned} \text{at } t=3 \quad -\frac{3}{25} + 0.065 &\stackrel{?}{=} \frac{3}{50} - 0.115 \\ &= -0.055 = -0.055 \quad (\text{Yes!}) \end{aligned}$$

$$\begin{aligned} \text{at } t=9 \quad \frac{9}{50} - 0.115 &\stackrel{?}{=} 0.065 \\ &= 0.065 \quad (\text{Yes!}) \end{aligned}$$

The given equations for the inductor current describe a current that is continuous, as must be the case since the given inductor voltage is bounded.

VP7-2

We need to check the values of the inductor current at the ends of the intervals.

$$\text{at } t=1 \quad -\frac{1}{200} + 0.025 \stackrel{?}{=} -\frac{1}{100} + 0.03 \quad (\text{Yes!})$$

$$\text{at } t=4 \quad -\frac{4}{100} + 0.03 \stackrel{?}{=} \frac{4}{100} - 0.03 \quad (\text{No!})$$

The equation for the inductor current indicates that this current changes instantaneously at $t = 4\text{s}$. This equation cannot be correct.

Design Problems

DP7-1

a) $\frac{d}{dt}v(t) = -6e^{-3t}$ is proportional to $i(t)$ so the element is a capacitor. $C = \frac{i(t)}{\frac{d}{dt}v(t)} = 0.5 \text{ F}$.

b) $\frac{d}{dt}i(t) = -6e^{-3t}$ is proportional to $v(t)$ so the element is an inductor. $L = \frac{v(t)}{\frac{d}{dt}i(t)} = 0.5 \text{ H}$.

c) $v(t)$ is proportional to $i(t)$ so the element is a resistor. $R = \frac{v(t)}{i(t)} = 2 \Omega$.

DP7-2

$$1.131 \cos(2t + 45^\circ) = 1.131 [\cos(45^\circ) \cos(2t) - \sin(45^\circ) \sin(2t)] \\ = 0.8 \cos 2t - 0.8 \sin 2t$$

The first term is proportional to the voltage. Associate it with the resistor. The noticing that

$$\int_{-\infty}^t v(\tau) d\tau = \int_{-\infty}^t 4 \cos 2t d\tau = 2 \sin 2t \\ \frac{d}{dt} v(t) = \frac{d}{dt} 4 \cos 2t = -8 \sin 2t$$

associate the second term with a capacitor to get the minus sign.

Then

$$R = \frac{4 \cos 2t}{i_1(t)} = \frac{4 \cos 2t}{0.8 \cos 2t} = 5 \Omega \text{ and} \\ C = \frac{i_2(t)}{\frac{d}{dt} 4 \cos 2t} = \frac{-0.8 \sin 2t}{-8 \sin 2t} = 0.1 \text{ F}$$

$$1.131 \cos(2t - 45^\circ) = 1.131 [\cos(-45^\circ) \cos(2t) - \sin(-45^\circ) \sin(2t)] \\ = 0.8 \cos 2t + 0.8 \sin 2t$$

The first term is proportional to the voltage. Associate it with the resistor. Then noticing that

$$\int_{-\infty}^t v(\tau) d\tau = \int_{-\infty}^t 4 \cos 2t d\tau = 2 \sin 2t \\ \frac{d}{dt} v(t) = \frac{d}{dt} 4 \cos 2t = -8 \sin 2t$$

associate the second term with an inductor to get the plus sign. Then

$$R = \frac{4 \cos 2t}{i_1(t)} = \frac{4 \cos 2t}{0.8 \cos 2t} = 5 \Omega \text{ and} \\ L = \frac{\int_{-\infty}^t 4 \cos 2t d\tau}{i_2(t)} = \frac{2 \sin 2t}{0.8 \sin 2t} = 2.5 \text{ H}$$

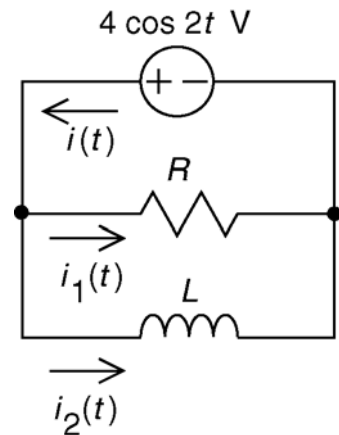
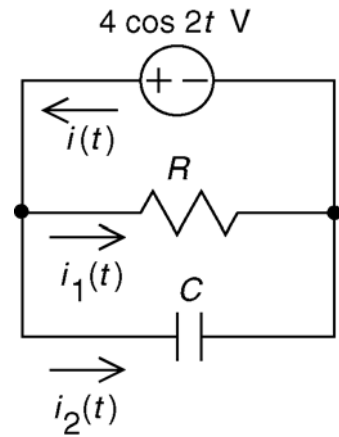

DP7-3

a)

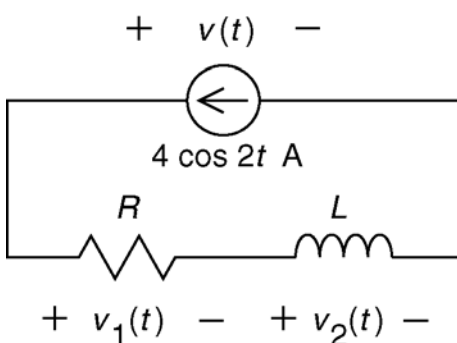

$$11.31 \cos(2t + 45^\circ) = 11.31 [\cos(45^\circ) \cos(2t) - \sin(45^\circ) \sin(2t)]$$

$$= 8 \cos 2t - 8 \sin 2t$$

The first term is proportional to the voltage. Associate it with the resistor. The noticing that

$$\int_{-\infty}^t i(\tau) d\tau = \int_{-\infty}^t 4 \cos 2\tau d\tau = 2 \sin 2t$$

$$\frac{d}{dt} i(t) = \frac{d}{dt} 4 \cos 2t = -8 \sin 2t$$

associate the second term with an inductor to get the minus sign. Then

$$R = \frac{v_1(t)}{4 \cos 2t} = \frac{8 \cos 2t}{4 \cos 2t} = 2 \Omega \quad \text{and} \quad L = \frac{v_2(t)}{\frac{d}{dt} 4 \cos 2t} = \frac{-8 \sin 2t}{-8 \sin 2t} = 1 \text{ H}$$

b)

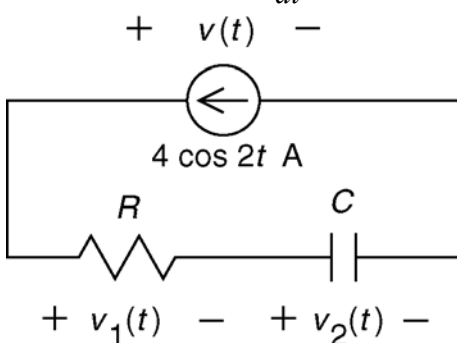

$$11.31 \cos(2t + 45^\circ) = 11.31 [\cos(-45^\circ) \cos(2t) - \sin(-45^\circ) \sin(2t)]$$

$$= 8 \cos 2t + 8 \sin 2t$$

The first term is proportional to the voltage. Associate it with the resistor. The noticing that

$$\int_{-\infty}^t i(\tau) d\tau = \int_{-\infty}^t 4 \cos 2\tau d\tau = 2 \sin 2t$$

$$\frac{d}{dt} i(t) = \frac{d}{dt} 4 \cos 2t = -8 \sin 2t$$

associate the second term with a capacitor to get the minus sign. Then

$$R = \frac{v_1(t)}{4 \cos 2t} = \frac{8 \cos 2t}{4 \cos 2t} = 2 \Omega \quad \text{and} \quad C = \frac{\int_{-\infty}^t 4 \cos 2\tau d\tau}{v_2(t)} = \frac{2 \sin 2t}{8 \sin 2t} = 0.25 \text{ F}$$

DP7-4

at $t=0^-$

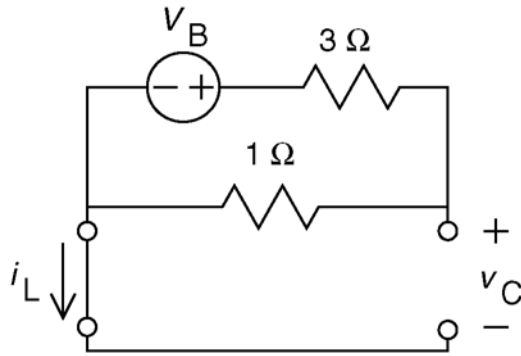

$$i_L(0^-) = 0$$

By voltage division: $v_C(0^-) = \frac{V_B}{4}$

We require $v_C(0^-) = 3 \text{ V}$ so

$$V_B = 12 \text{ V}$$

at $t=0^+$

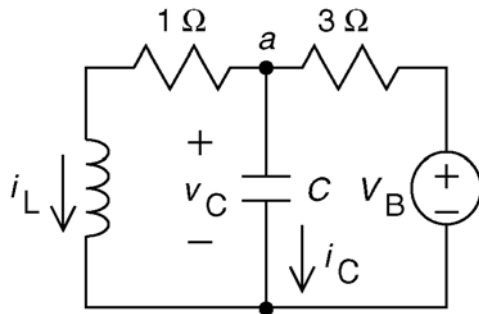

Now we will check $\left. \frac{dv_C}{dt} \right|_{t=0^+}$

First:

$$i_L(0^+) = i_L(0^-) = 0$$

and

$$v_C(0^+) = v_C(0^-) = 3 \text{ V}$$

Apply KCL at node a :

$$i_L(0^+) + i_C(0^+) = \frac{V_B - v_C(0^+)}{3}$$

$$0 + i_C(0^+) = \frac{12 - 3}{3} \Rightarrow i_C(0^+) = 3 \text{ A}$$

Finally

$$\left. \frac{dv_C}{dt} \right|_{t=0^+} = \frac{i_C(0^+)}{C} = \frac{3}{0.125} = 24 \frac{\text{V}}{\text{s}}$$

as required.

DP7-5

We require $\frac{1}{2} L i_L^2 = \frac{1}{2} C v_C^2$ where i_L and v_C are the steady state inductor current and capacitor

voltage. At steady state, $i_L = \frac{v_C}{R}$. Then

$$L \left(\frac{v_C}{R} \right)^2 = C v_C^2 \Rightarrow C = \frac{L}{R^2} \Rightarrow R = \sqrt{\frac{L}{C}} = \sqrt{\frac{10^{-2}}{10^{-6}}} = \sqrt{10^4} = 10^2 \Omega$$

so $R = 100 \Omega$.

Chapter 8 – The Complete Response of RL and RC Circuit

Exercises

Ex. 8.3-1

Before the switch closes:

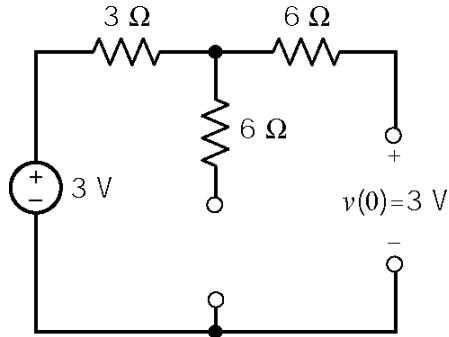

After the switch closes:

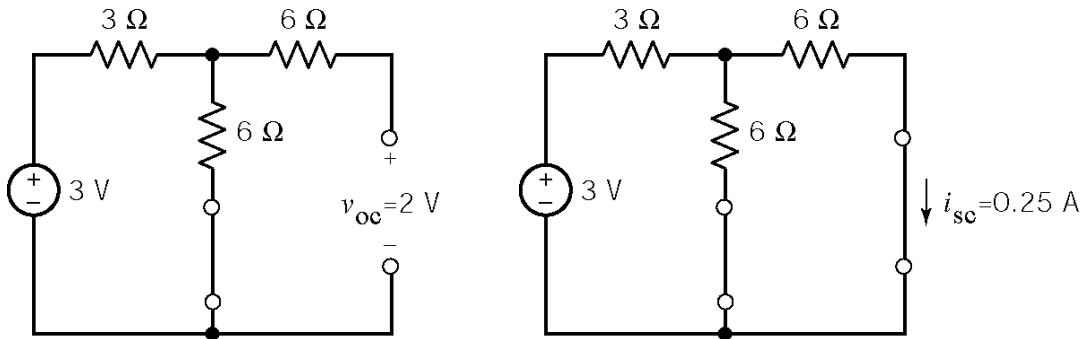

Therefore $R_t = \frac{2}{0.25} = 8 \Omega$ so $\tau = 8(0.05) = 0.4 \text{ s}$.

Finally, $v(t) = v_{oc} + (v(0) - v_{oc}) e^{-t/\tau} = 2 + e^{-2.5t} \text{ V}$ for $t > 0$

Ex. 8.3-2

Before the switch closes:

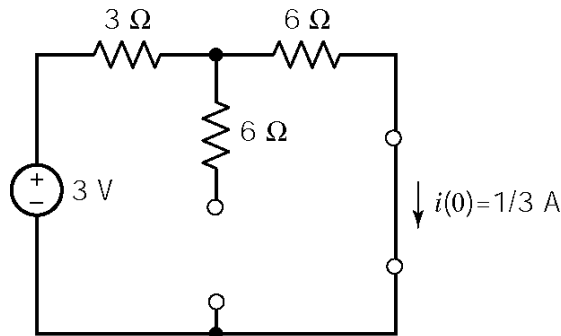

After the switch closes:

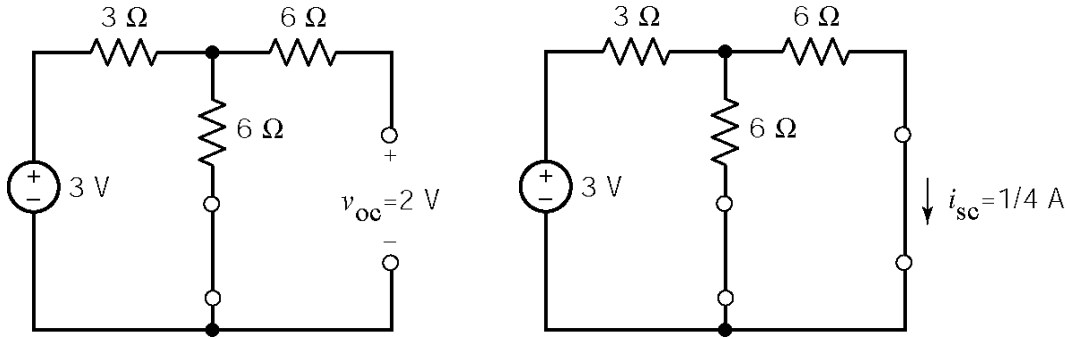

Therefore $R_t = \frac{2}{0.25} = 8 \Omega$ so $\tau = \frac{6}{8} = 0.75 \text{ s}$.

Finally, $i(t) = i_{sc} + (i(0) - i_{sc}) e^{-t/\tau} = \frac{1}{4} + \frac{1}{12} e^{-1.33t} \text{ A}$ for $t > 0$

Ex. 8.3-3

At steady-state, immediately before $t = 0$:

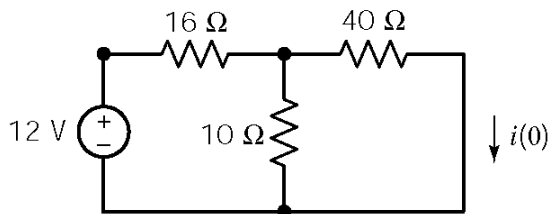

$$i(0) = \left(\frac{10}{10+40} \right) \left(\frac{12}{16+40 \parallel 10} \right) = 0.1 \text{ A}$$

After $t = 0$, the Norton equivalent of the circuit connected to the inductor is found to be

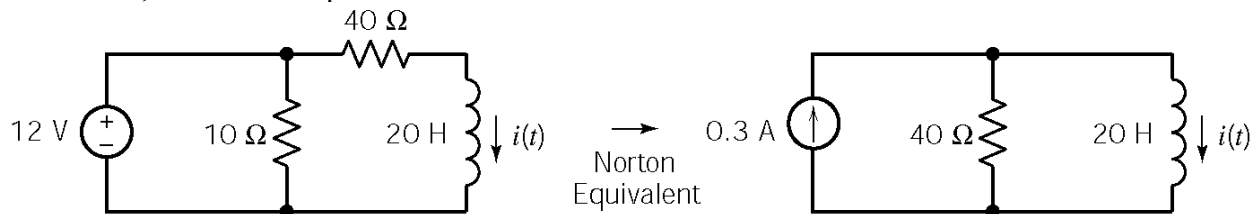

$$\text{so } I_{sc} = 0.3 \text{ A}, R_t = 40 \Omega, \tau = \frac{L}{R_t} = \frac{20}{40} = \frac{1}{2} \text{ s}$$

$$\text{Finally: } i(t) = (0.1 - 0.3)e^{-2t} + 0.3 = 0.3 - 0.2e^{-2t} \text{ A}$$

Ex. 8.3-4

At steady-state, immediately before $t = 0$

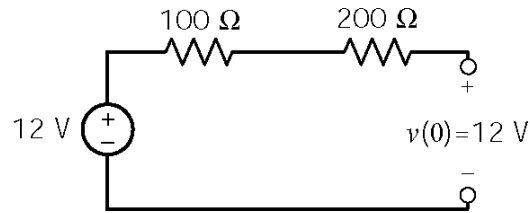

After $t = 0$, we have:

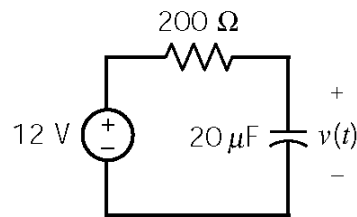

so $V_{oc} = 12 \text{ V}$, $R_t = 200 \Omega$, $\tau = R_t C = (200)(20 \cdot 10^{-6}) = 4 \text{ ms}$

Finally: $v(t) = (12 - 12)e^{-t/4} + 12 = 12 \text{ V}$

Ex. 8.3-5

Immediately before $t = 0$, $i(0) = 0$.

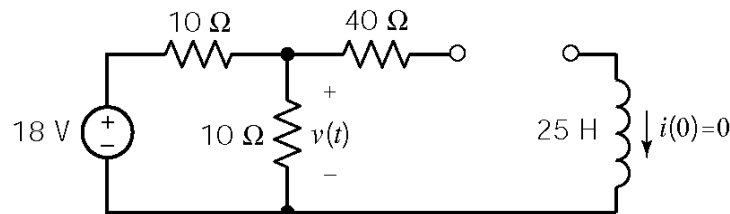

After $t = 0$, replace the circuit connected to the inductor by its Norton equivalent to calculate the inductor current:

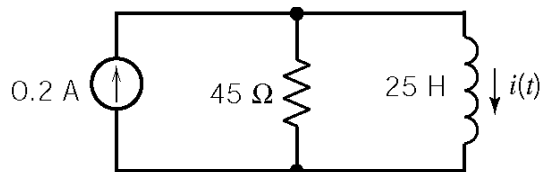

$$I_{sc} = 0.2 \text{ A}, R_t = 45 \Omega, \tau = \frac{L}{R_{th}} = \frac{25}{45} = \frac{5}{9}$$

$$\text{So } i(t) = 0.2(1 - e^{-1.8t}) \text{ A}$$

Now that we have the inductor current, we can calculate $v(t)$:

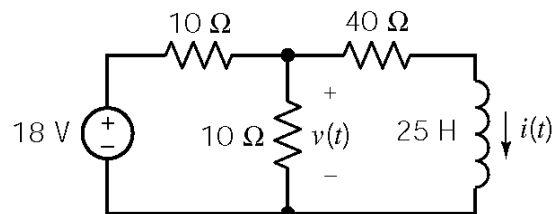

$$\begin{aligned} v(t) &= 40 i(t) + 25 \frac{d}{dt} i(t) \\ &= 8(1 - e^{-1.8t}) + 5(1.8)e^{-1.8t} \\ &= 8 + e^{-1.8t} \text{ V for } t > 0 \end{aligned}$$

Ex. 8.3-6

At steady-state, immediately before $t = 0$

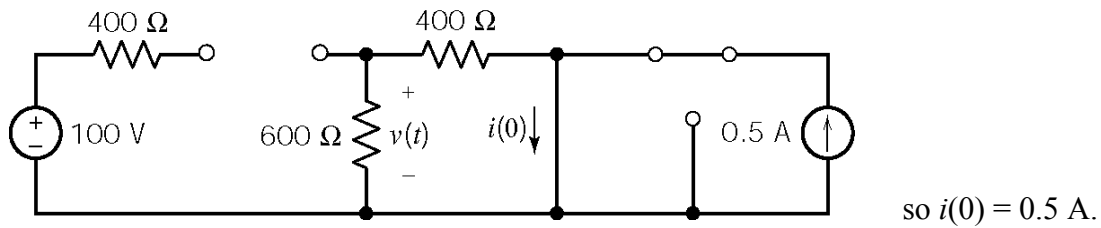

After $t > 0$: Replace the circuit connected to the inductor by its Norton equivalent to get

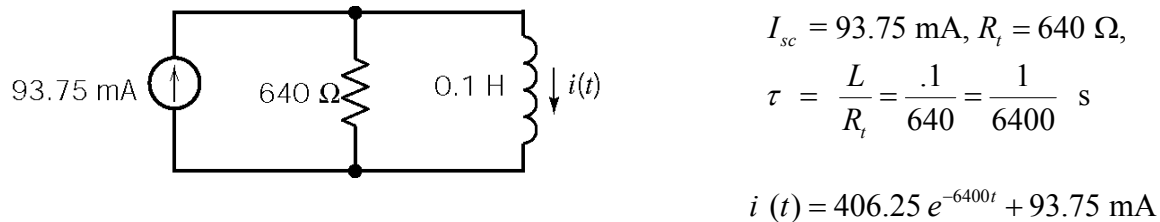

Finally:

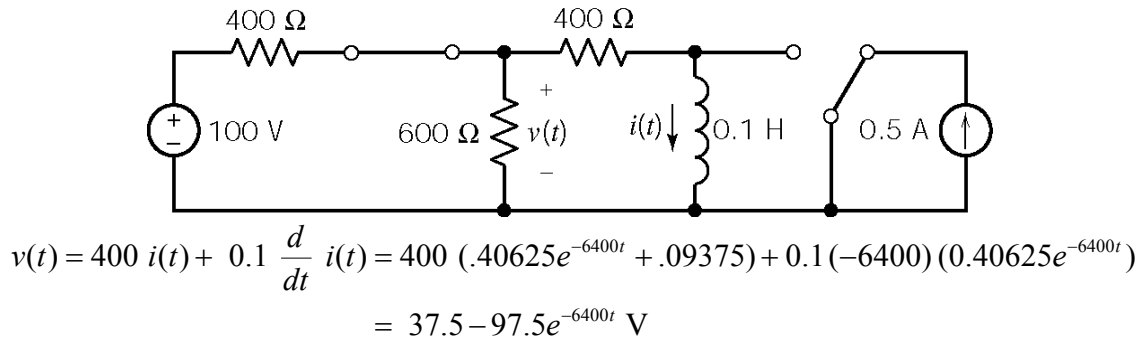

Ex. 8.4-1

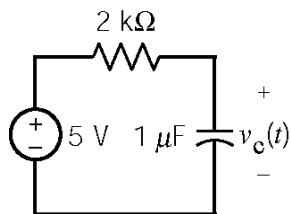

$$\tau = (2 \times 10^3)(1 \times 10^{-6}) = 2 \times 10^{-3} \text{ s}$$

$$v_c(t) = 5 + (1.5 - 5)e^{-500t} \text{ V}$$

$$v_c(0.001) = 5 - 3.5e^{-0.5} = 2.88 \text{ V}$$

So $v_c(t)$ will be equal to v_T at $t = 1 \text{ ms}$ if $v_T = 2.88 \text{ V}$.

Ex. 8.4-2

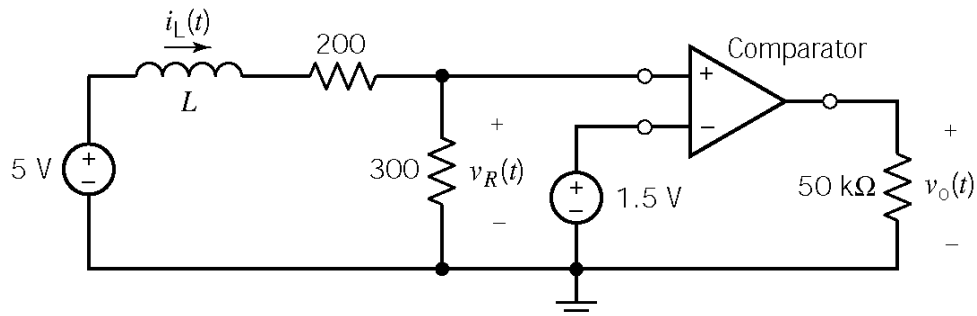

$$\left. \begin{aligned} i_L(0) &= 1 \text{ mA}, I_{sc} = 10 \text{ mA} \\ R_t &= 500 \Omega, \tau = \frac{L}{500} \end{aligned} \right\} \Rightarrow i_L(t) = 10 - 9 e^{-\frac{500}{L}t} \text{ mA}$$

$$v_R(t) = 300 i_L(t) = 3 - 2.7 e^{-\frac{500}{L}t} \text{ V}$$

We require that $v_R(t) = 1.5 \text{ V}$ at $t = 10 \text{ ms} = 0.01 \text{ s}$. That is

$$1.5 = 3 - 2.7 e^{-\frac{500}{L}(0.01)} \Rightarrow L = \frac{5}{0.588} = 8.5 \text{ H}$$

Ex. 8.6-1

$0 < t < t_1$

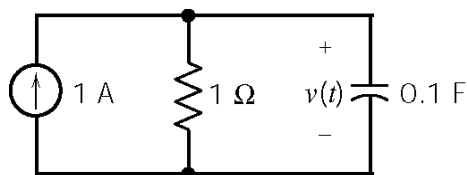

$$v(t) = v(\infty) + A e^{-t/RC} \text{ where } v(\infty) = (1 \text{ A})(1 \Omega) = 1 \text{ V}$$

$$v(t) = 1 + A e^{-t/(1)(1)} = 1 + A e^{-10t}$$

$$\text{Now } v(0^-) = v(0^+) = 0 = 1 + A \Rightarrow A = -1$$

$$\therefore v(t) = 1 - e^{-10t} \text{ V}$$

$t > t_1$

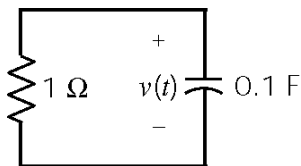

$$t_1 = 0.5 \text{ s}, \quad v(t) = v(t_1) e^{-\frac{t-t_1}{(1)(1)}} = v(0.5) e^{-10(t-0.5)}$$

$$\text{Now } v(0.5) = 1 - e^{-10(0.5)} = 0.993 \text{ V}$$

$$\therefore v(t) = 0.993 e^{-10(t-0.5)} \text{ V}$$

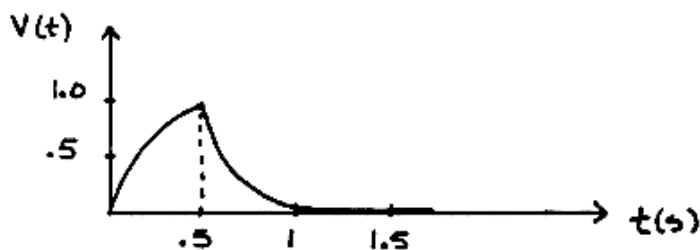

Ex. 8 6-2

$t < 0$ no sources $\therefore v(0^-) = v(0^+) = 0$

$0 < t < t_1$

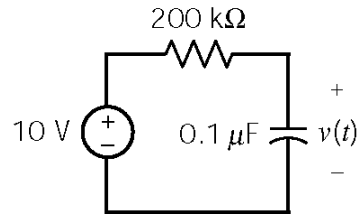

$$v(t) = v(\infty) + Ae^{-t/RC} = v(\infty) + Ae^{-t/2 \times 10^5 (10^{-7})}$$

where for $t = \infty$ (steady-state)

\therefore capacitor becomes an open $\Rightarrow v(\infty) = 10$ V

$$v(t) = 10 + Ae^{-50t}$$

Now $v(0) = 0 = 10 + A \Rightarrow A = -10$

$$\therefore \underline{v(t) = 10(1 - e^{-50t}) \text{ V}}$$

$t > t_1$, $t_1 = .1$ s

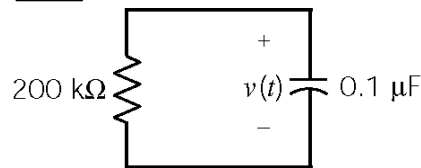

$$v(t) = v(.1) e^{-50(t-.1)}$$

where $v(.1) = 10(1 - e^{-50(.1)}) = 9.93$ V

$$\therefore \underline{v(t) = 9.93e^{-50(t-.1)} \text{ V}}$$

Ex. 8.6-3

For $t < 0$ $i = 0$.

For $0 < t < 0.2$ s

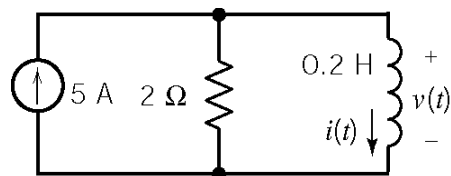

$$\left. \begin{array}{l} \text{KCL: } -5 + v/2 + i = 0 \\ \text{also: } v = 0.2 \frac{di}{dt} \end{array} \right\} \frac{di}{dt} + 10i = 50$$

$$\therefore i(t) = 5 + Ae^{-10t}$$

$i(0) = 0 = 5 + A \Rightarrow A = -5$

$$\text{so we have } \underline{i(t) = 5(1 - e^{-10t}) \text{ A}}$$

For $t > 0.2$ s

$$i(0.2) = 4.32 \text{ A} \quad \therefore \underline{i(t) = 4.32e^{-10(t-.2)} \text{ A}}$$

Ex. 8.7-1

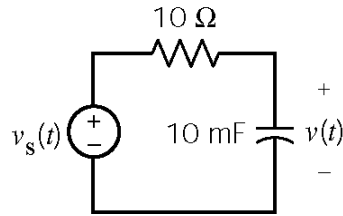

$$v_s(t) = 10 \sin 20t \text{ V}$$

$$\text{KVL: } -10 \sin 20t + 10 \left(.01 \frac{d v(t)}{dt} \right) + v(t) = 0$$

$$\Rightarrow \frac{d v(t)}{dt} + 10 v(t) = 100 \sin 20t$$

Natural response: $v_n(t) = A e^{-t/\tau}$ where $\tau = R_t C \therefore v_n(t) = A e^{-10t}$

Forced response: try $v_f(t) = B_1 \cos 20t + B_2 \sin 20t$

Plugging $v_f(t)$ into the differential equation and equating like terms yields: $B_1 = -4$ & $B_2 = 2$

Complete response: $v(t) = v_n(t) + v_f(t)$

$$v(t) = A e^{-10t} - 4 \cos 20t + 2 \sin 20t$$

Now $v(0^-) = v(0^+) = 0 = A - 4 \therefore A = 4$

$$\therefore \underline{v(t) = 4 e^{-10t} - 4 \cos 20t + 2 \sin 20t \text{ V}}$$

Ex. 8.7-2

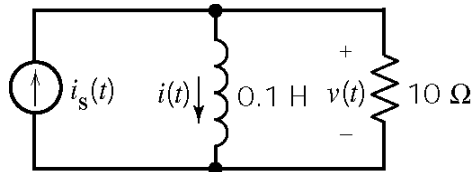

$$i_s(t) = 10 e^{-5t} \text{ for } t > 0$$

$$\text{KCL at top node: } -10 e^{-5t} + i(t) + v(t)/10 = 0$$

$$\text{Now } v(t) = 0.1 \frac{di(t)}{dt} \Rightarrow \underline{\underline{\frac{di(t)}{dt} + 100 i(t) = 1000 e^{-5t}}}$$

Natural response: $i_n(t) = A e^{-t/\tau}$ where $\tau = L/R_t \therefore i_n(t) = A e^{-100t}$

Forced response: try $i_f(t) = B e^{-5t}$ & plug into the differential equation

$$-5 B e^{-5t} + 100 B e^{-5t} = 1000 e^{-5t} \Rightarrow B = 10.53$$

Complete response: $i(t) = A e^{-100t} + 10.53 e^{-5t}$

Now $i(0^-) = i(0^+) = 0 = A + 10.53 \Rightarrow A = -10.53$

$$\therefore \underline{i(t) = 10.53 (e^{-5t} - e^{-100t}) \text{ A}}$$

Ex. 8.7-3

When the switch is closed, the inductor current is $i_L = v_s / R = v_s$. When the switch opens, the inductor current is forced to change instantaneously. The energy stored in the inductor instantaneously dissipates in the spark. To prevent the spark, add a resistor (say 1 kΩ) across the switch terminals.

Problems

Section 8.3: The Response of a First Order Circuit to a Constant Input

P8.3-1

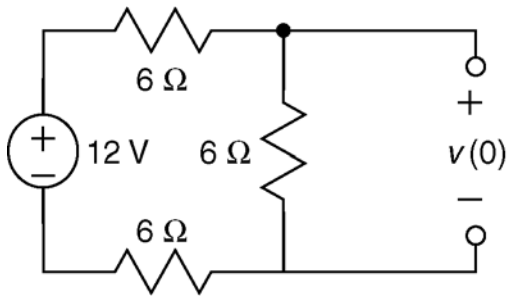

Here is the circuit before $t = 0$, when the switch is open and the circuit is at steady state. The open switch is modeled as an open circuit.

A capacitor in a steady-state dc circuit acts like an open circuit, so an open circuit replaces the capacitor. The voltage across that open circuit is the initial capacitor voltage, $v(0)$.

By voltage division

$$v(0) = \frac{6}{6+6+6}(12) = 4 \text{ V}$$

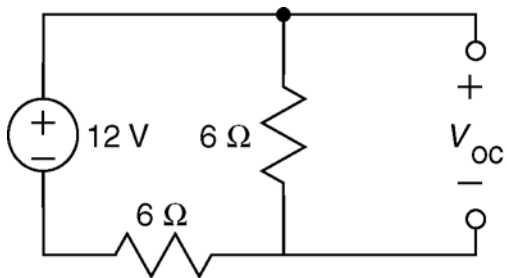

Next, consider the circuit after the switch closes. The closed switch is modeled as a short circuit.

We need to find the Thevenin equivalent of the part of the circuit connected to the capacitor. Here's the circuit used to calculate the open circuit voltage, V_{oc} .

$$V_{oc} = \frac{6}{6+6}(12) = 6 \text{ V}$$

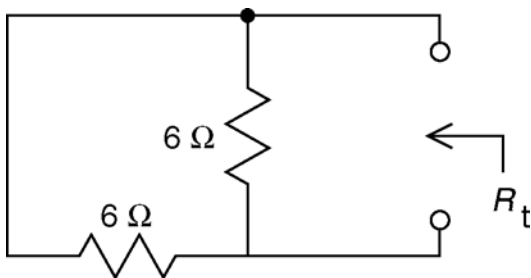

Here is the circuit that is used to determine R_t . A short circuit has replaced the closed switch. Independent sources are set to zero when calculating R_t , so the voltage source has been replaced by a short circuit.

$$R_t = \frac{(6)(6)}{6+6} = 3 \text{ } \Omega$$

Then

$$\tau = R_t C = 3(0.25) = 0.75 \text{ s}$$

Finally,

$$v(t) = V_{oc} + (v(0) - V_{oc})e^{-t/\tau} = 6 - 2e^{-1.33t} \text{ V for } t > 0$$

P8.3-2

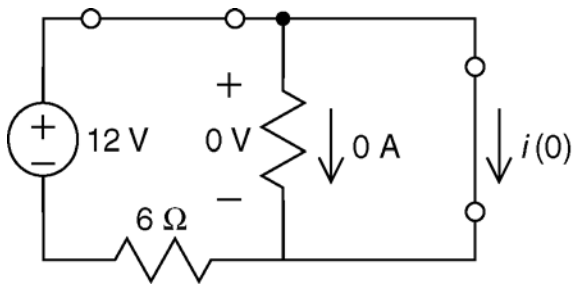

Here is the circuit before $t = 0$, when the switch is closed and the circuit is at steady state. The closed switch is modeled as a short circuit.

An inductor in a steady-state dc circuit acts like an short circuit, so a short circuit replaces the inductor. The current in that short circuit is the initial inductor current, $i(0)$.

$$i(0) = \frac{12}{6} = 2 \text{ A}$$

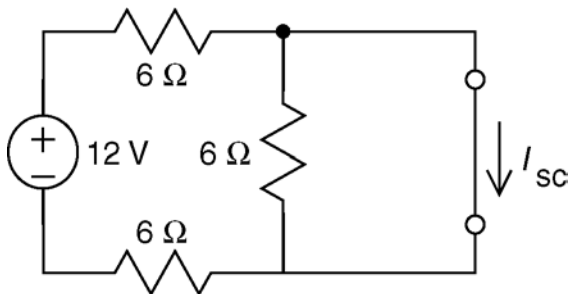

Next, consider the circuit after the switch opens. The open switch is modeled as an open circuit.

We need to find the Norton equivalent of the part of the circuit connected to the inductor. Here's the circuit used to calculate the short circuit current, I_{sc} .

$$I_{sc} = \frac{12}{6+6} = 1 \text{ A}$$

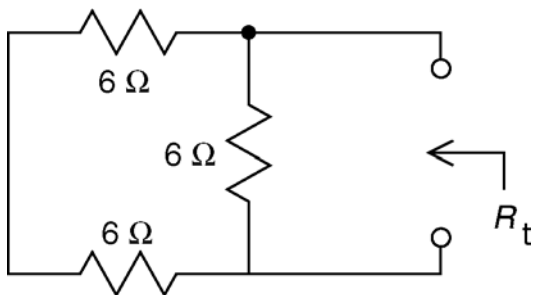

Here is the circuit that is used to determine R_t . An open circuit has replaced the open switch. Independent sources are set to zero when calculating R_t , so the voltage source has been replaced by an short circuit.

$$R_t = \frac{(6+6)(6)}{(6+6)+6} = 4 \text{ } \Omega$$

Then

$$\tau = \frac{L}{R_t} = \frac{8}{4} = 2 \text{ s}$$

Finally,

$$i(t) = I_{sc} + (i(0) - I_{sc}) e^{-t/\tau} = 1 + e^{-0.5t} \text{ A for } t > 0$$

P8.3-3

Before the switch closes:

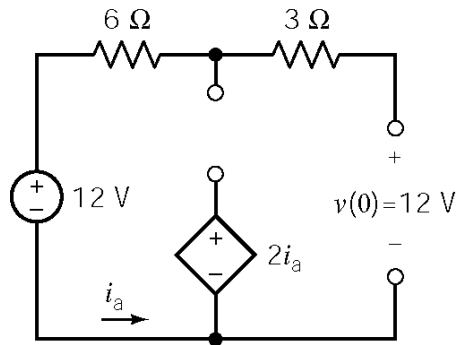

After the switch closes:

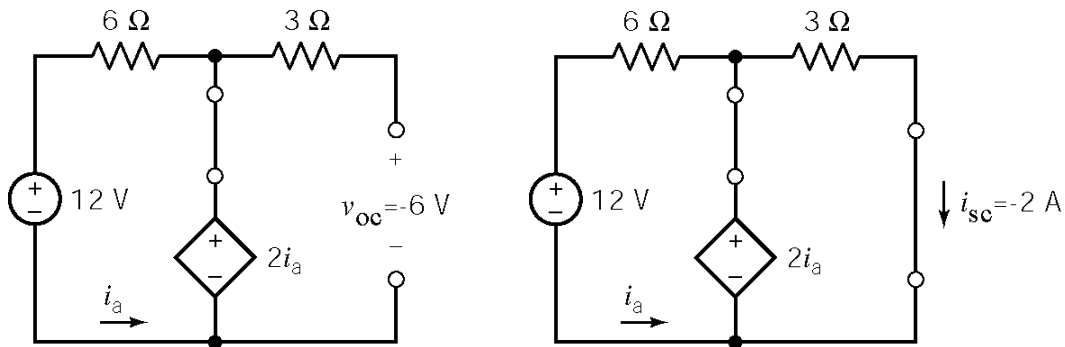

Therefore $R_t = \frac{-6}{-2} = 3 \Omega$ so $\tau = 3(0.05) = 0.15 \text{ s}$.

Finally, $v(t) = v_{oc} + (v(0) - v_{oc}) e^{-t/\tau} = -6 + 18 e^{-6.67t} \text{ V}$ for $t > 0$

P8.3-4

Before the switch closes:

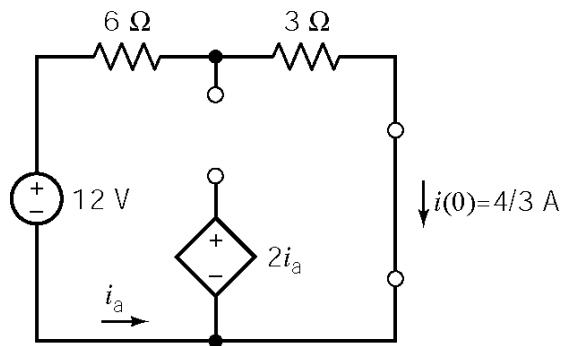

After the switch closes:

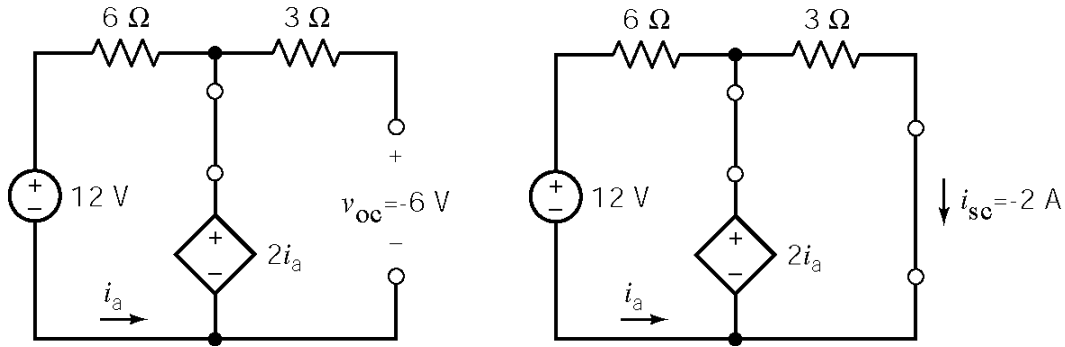

Therefore $R_t = \frac{-6}{-2} = 3 \Omega$ so $\tau = \frac{6}{3} = 2 \text{ s}$.

Finally, $i(t) = i_{sc} + (i(0) - i_{sc}) e^{-\frac{t}{\tau}} = -2 + \frac{10}{3} e^{-0.5t} \text{ A}$ for $t > 0$

P8.3-5

Before the switch opens, $v_o(t) = 5 \text{ V} \Rightarrow v_o(0) = 5 \text{ V}$. After the switch opens the part of the circuit connected to the capacitor can be replaced by its Thevenin equivalent circuit to get:

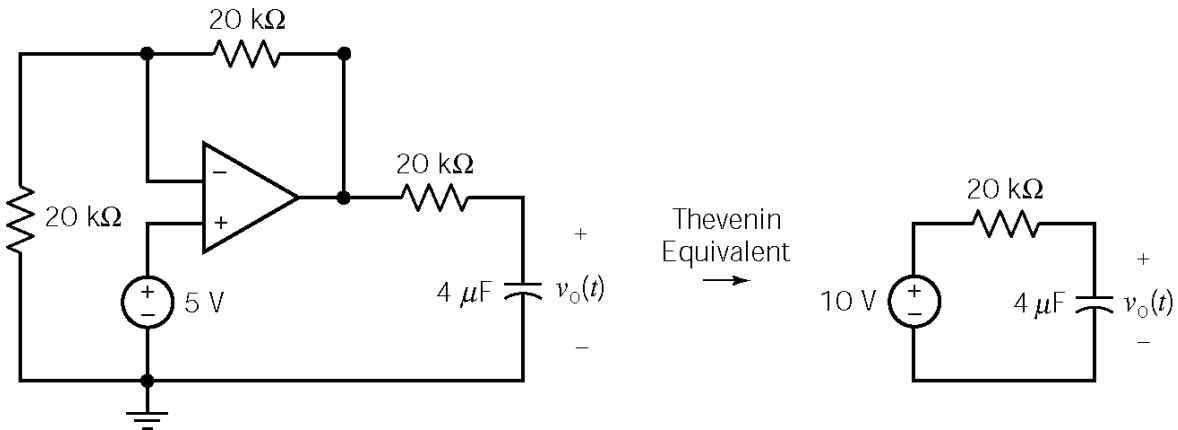

Therefore $\tau = (20 \times 10^3)(4 \times 10^{-6}) = 0.08 \text{ s}$.

Next, $v_C(t) = v_{oc} + (v(0) - v_{oc}) e^{-\frac{t}{\tau}} = 10 - 5 e^{-12.5t} \text{ V}$ for $t > 0$

Finally, $v_o(t) = v_C(t) = 10 - 5 e^{-12.5t} \text{ V}$ for $t > 0$

P8.3-6

Before the switch opens, $v_o(t) = 5 \text{ V} \Rightarrow v_o(0) = 5 \text{ V}$. After the switch opens the part of the circuit connected to the capacitor can be replaced by it's Norton equivalent circuit to get:

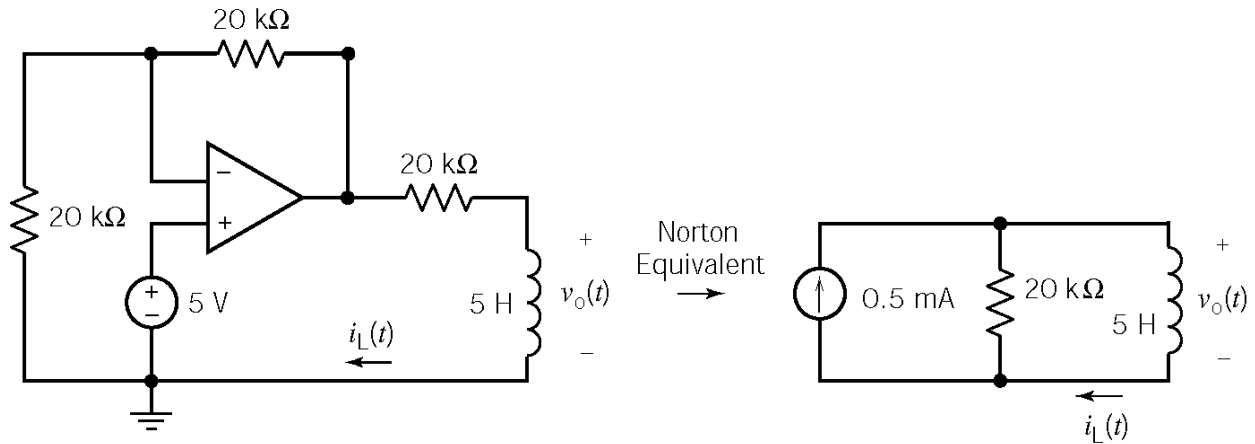

Therefore $\tau = \frac{5}{20 \times 10^3} = 0.25 \text{ ms}$.

Next, $i_L(t) = i_{sc} + (i_L(0) - i_{sc}) e^{-\frac{t}{\tau}} = 0.5 - 0.25 e^{-4000t} \text{ mA}$ for $t > 0$

Finally, $v_o(t) = 5 \frac{d}{dt} i_L(t) = 5 e^{-4000t} \text{ V}$ for $t > 0$

P8.3-7

At $t = 0^-$ (steady-state)

Since the input to this circuit is constant, the inductor will act like a short circuit when the circuit is at steady-state:

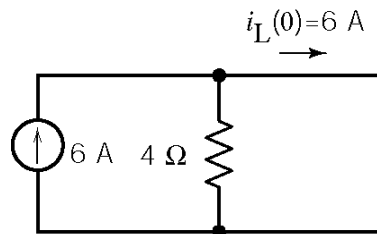

for $t > 0$

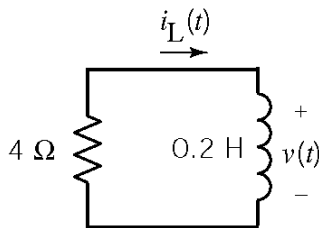

$i_L(t) = i_L(0) e^{-(R/L)t} = 6 e^{-20t} \text{ A}$

P8.3-8

Before the switch opens, the circuit will be at steady state. Because the only input to this circuit is the constant voltage of the voltage source, all of the element currents and voltages, including the capacitor voltage, will have constant values. Opening the switch disturbs the circuit. Eventually the disturbance dies out and the circuit is again at steady state. All the element currents and voltages will again have constant values, but probably different constant values than they had before the switch opened.

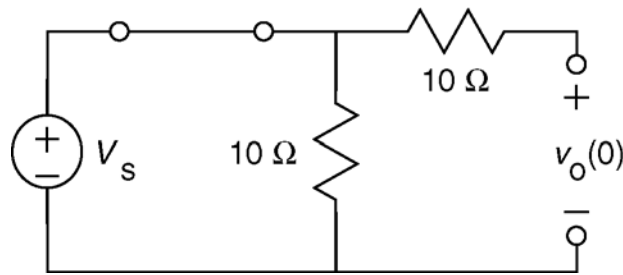

Here is the circuit before $t = 0$, when the switch is closed and the circuit is at steady state. The closed switch is modeled as a short circuit. The combination of resistor and a short circuit connected is equivalent to a short circuit. Consequently, a short circuit replaces the switch and the resistor R . A capacitor in a steady-state dc circuit acts like an open circuit, so an open circuit replaces the capacitor. The voltage across that open circuit is the capacitor voltage, $v_o(t)$.

Because the circuit is at steady state, the value of the capacitor voltage will be constant. This constant is the value of the capacitor voltage just before the switch opens. In the absence of unbounded currents, the voltage of a capacitor must be continuous. The value of the capacitor voltage immediately after the switch opens is equal to the value immediately before the switch opens. This value is called the initial condition of the capacitor and has been labeled as $v_o(0)$. There is no current in the horizontal resistor due to the open circuit. Consequently, $v_o(0)$ is equal to the voltage across the vertical resistor, which is equal to the voltage source voltage. Therefore

$$v_o(0) = V_s$$

The value of $v_o(0)$ can also be obtained by setting $t = 0$ in the equation for $v_o(t)$. Doing so gives

$$v_o(0) = 2 + 8e^0 = 10 \text{ V}$$

Consequently,

$$V_s = 10 \text{ V}$$

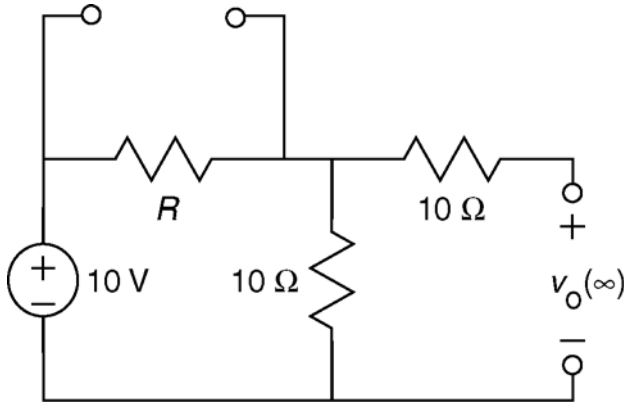

Next, consider the circuit after the switch opens. Eventually (certainly as $t \rightarrow \infty$) the circuit will again be at steady state. Here is the circuit at $t = \infty$, when the switch is open and the circuit is at steady state. The open switch is modeled as an open circuit. A capacitor in a steady-state dc circuit acts like an open circuit, so an open circuit replaces the capacitor. The voltage across that open circuit is the steady-state capacitor voltage, $v_o(\infty)$. There is no current in the horizontal resistor and $v_o(\infty)$ is equal to the voltage across the vertical resistor. Using voltage division,

$$v_o(\infty) = \frac{10}{R+10}(10)$$

The value of $v_o(\infty)$ can also be obtained by setting $t = \infty$ in the equation for $v_o(t)$. Doing so gives

$$v_o(\infty) = 2 + 8e^{-\infty} = 2 \text{ V}$$

Consequently,

$$2 = \frac{10}{R+10}(10) \Rightarrow 2R+20=100 \Rightarrow R=40 \Omega$$

Finally, the exponential part of $v_o(t)$ is known to be of the form $e^{-t/\tau}$ where $\tau = R_t C$ and R_t is the Thevenin resistance of the part of the circuit connected to the capacitor.

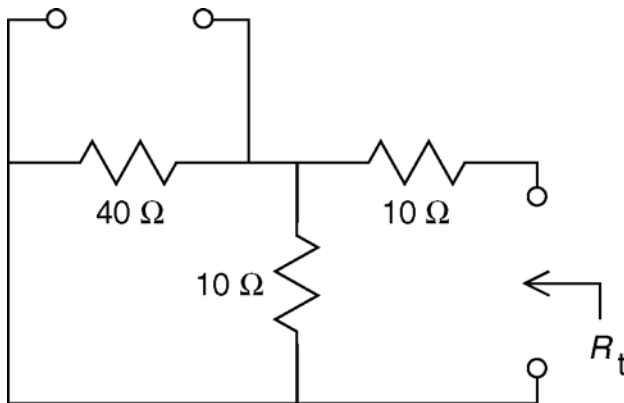

Here is the circuit that is used to determine R_t . An open circuit has replaced the open switch. Independent sources are set to zero when calculating R_t , so the voltage source has been replaced by a short circuit.

$$R_t = 10 + \frac{(40)(10)}{40+10} = 18 \Omega$$

$$\tau = R_t C = 18 C$$

From the equation for $v_o(t)$

$$-0.5t = -\frac{t}{\tau} \Rightarrow \tau = 2 \text{ s}$$

Consequently,

$$2 = 18 C \Rightarrow C = 0.111 = 111 \text{ mF}$$

P8.3-9:

Before the switch closes, the circuit will be at steady state. Because the only input to this circuit is the constant voltage of the voltage source, all of the element currents and voltages, including the inductor current, will have constant values. Closing the switch disturbs the circuit by shorting out the resistor R_1 . Eventually the disturbance dies out and the circuit is again at steady state. All the element currents and voltages will again have constant values, but probably different constant values than they had before the switch closed.

The inductor current is equal to the current in the $3\ \Omega$ resistor. Consequently,

$$i(t) = \frac{v_o(t)}{3} = \frac{6 - 3e^{-0.35t}}{3} = 2 - e^{-0.35t} \text{ A when } t > 0$$

In the absence of unbounded voltages, the current in any inductor is continuous. Consequently, the value of the inductor current immediately before $t = 0$ is equal to the value immediately after $t = 0$.

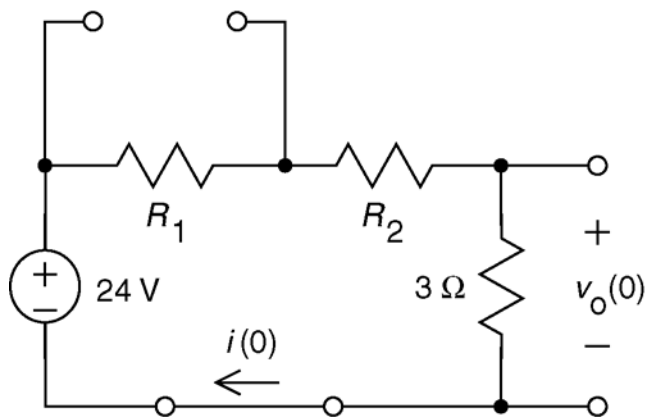

Here is the circuit before $t = 0$, when the switch is open and the circuit is at steady state. The open switch is modeled as an open circuit. An inductor in a steady-state dc circuit acts like a short circuit, so a short circuit replaces the inductor. The current in that short circuit is the steady state inductor current, $i(0)$. Apply KVL to the loop to get

$$R_1 i(0) + R_2 i(0) + 3 i(0) - 24 = 0$$

$$\Rightarrow i(0) = \frac{24}{R_1 + R_2 + 3}$$

The value of $i(0)$ can also be obtained by setting $t = 0$ in the equation for $i(t)$. Do so gives

$$i(0) = 2 - e^0 = 1 \text{ A}$$

Consequently,

$$1 = \frac{24}{R_1 + R_2 + 3} \Rightarrow R_1 + R_2 = 21$$

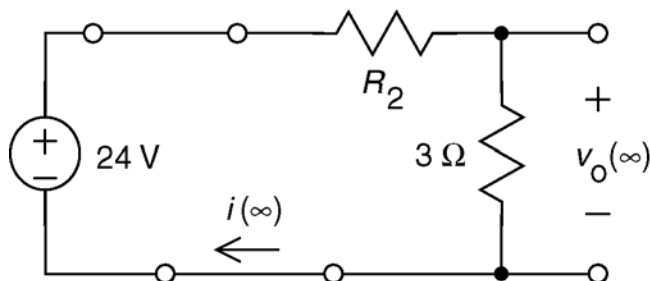

Next, consider the circuit after the switch closes. Here is the circuit at $t = \infty$, when the switch is closed and the circuit is at steady state. The closed switch is modeled as a short circuit. The combination of resistor and a short circuit connected is equivalent to a short circuit. Consequently, a short circuit replaces the switch and the resistor R_1 .

An inductor in a steady-state dc circuit acts like a short circuit, so a short circuit replaces the inductor. The current in that short circuit is the steady state inductor current, $i(\infty)$. Apply KVL to the loop to get

$$R_2 i(\infty) + 3 i(\infty) - 24 = 0 \Rightarrow i(\infty) = \frac{24}{R_2 + 3}$$

The value of $i(\infty)$ can also be obtained by setting $t = \infty$ in the equation for $i(t)$. Doing so gives

$$i(\infty) = 2 - e^{-\infty} = 2 \text{ A}$$

Consequently

$$2 = \frac{24}{R_2 + 3} \Rightarrow R_2 = 9 \ \Omega$$

Then

$$R_1 = 12 \ \Omega$$

Finally, the exponential part of $i(t)$ is known to be of the form $e^{-t/\tau}$ where $\tau = \frac{L}{R_t}$ and

R_t is the Thevenin resistance of the part of the circuit that is connected to the inductor.

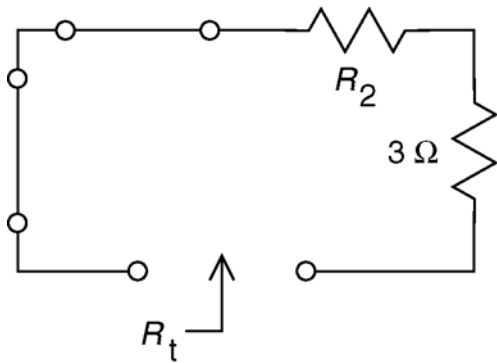

Here is shows the circuit that is used to determine R_t . A short circuit has replaced combination of resistor R_1 and the closed switch. Independent sources are set to zero when calculating R_t , so the voltage source has been replaced by an short circuit.

$$R_t = R_2 + 3 = 9 + 3 = 12 \ \Omega$$

so

$$\tau = \frac{L}{R_t} = \frac{L}{12}$$

From the equation for $i(t)$

$$-0.35 t = -\frac{t}{\tau} \Rightarrow \tau = 2.857 \text{ s}$$

Consequently,

$$2.857 = \frac{L}{12} \Rightarrow L = 34.28 \text{ H}$$

P8.3-10

First, use source transformations to obtain the equivalent circuit

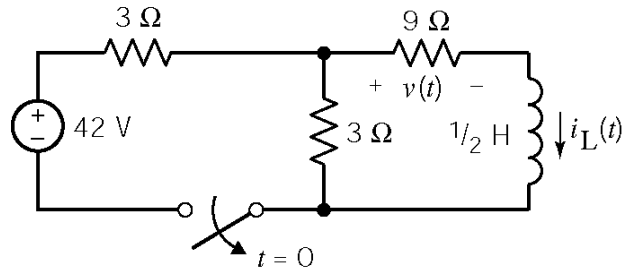

for $t < 0$:

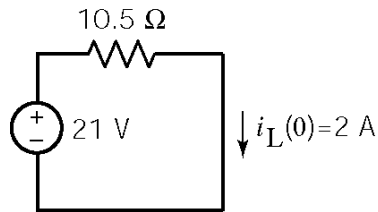

for $t > 0$:

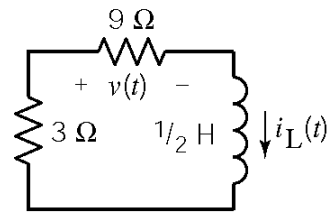

So $i_L(0) = 2 \text{ A}$, $I_{sc} = 0$, $R_t = 3 + 9 = 12 \Omega$, $\tau = \frac{L}{R_t} = \frac{1/2}{12} = \frac{1}{24} \text{ s}$

and $i_L(t) = 2e^{-24t} \quad t > 0$

Finally $v(t) = 9 i_L(t) = 18 e^{-24t} \quad t > 0$

Section 8-4: Sequential Switching

P8.4-1

Replace the part of the circuit connected to the capacitor by its Thevenin equivalent circuit to get:

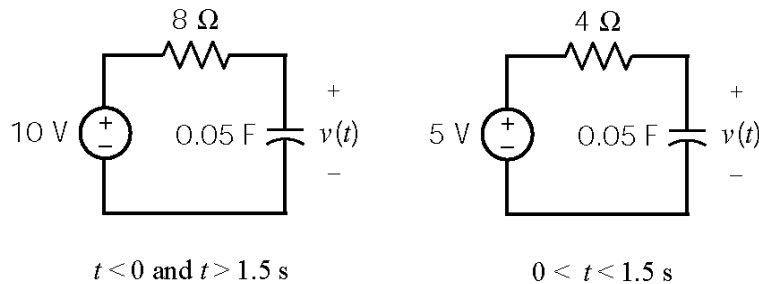

Before the switch closes at $t = 0$ the circuit is at steady state so $v(0) = 10$ V. For $0 < t < 1.5$ s, $v_{oc} = 5$ V and $R_t = 4$ Ω so $\tau = 4 \times 0.05 = 0.2$ s. Therefore

$$v(t) = v_{oc} + (v(0) - v_{oc}) e^{-t/\tau} = 5 + 5e^{-5t} \text{ V for } 0 < t < 1.5 \text{ s}$$

At $t = 1.5$ s, $v(1.5) = 5 + 5e^{-0.05(1.5)} = 5$ V. For $1.5 \text{ s} < t$, $v_{oc} = 10$ V and $R_t = 8$ Ω so $\tau = 8 \times 0.05 = 0.4$ s. Therefore

$$v(t) = v_{oc} + (v(1.5) - v_{oc}) e^{-(t-1.5)/\tau} = 10 - 5e^{-2.5(t-1.5)} \text{ V for } 1.5 \text{ s} < t$$

Finally

$$v(t) = \begin{cases} 5 + 5e^{-5t} \text{ V} & \text{for } 0 < t < 1.5 \text{ s} \\ 10 - 5e^{-2.5(t-1.5)} \text{ V} & \text{for } 1.5 \text{ s} < t \end{cases}$$

P8.4-2

Replace the part of the circuit connected to the inductor by its Norton equivalent circuit to get:

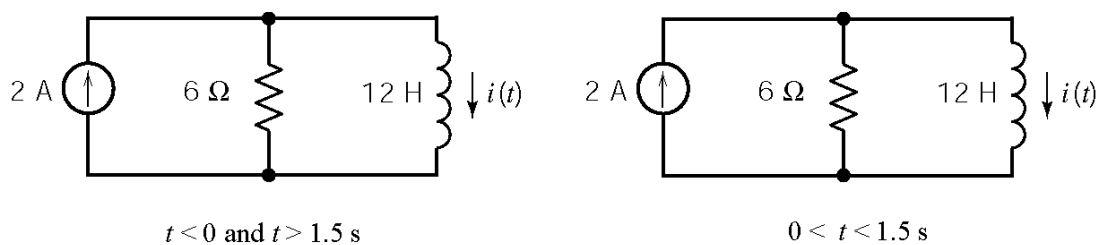

Before the switch closes at $t = 0$ the circuit is at steady state so $i(0) = 3$ A. For $0 < t < 1.5$ s, $i_{sc} = 2$ A and $R_t = 6$ Ω so $\tau = \frac{12}{6} = 2$ s. Therefore

$$i(t) = i_{sc} + (i(0) - i_{sc}) e^{-t/\tau} = 2 + e^{-0.5t} \text{ A for } 0 < t < 1.5 \text{ s}$$

At $t=1.5$ s, $i(1.5) = 2 + e^{-0.5(1.5)} = 2.47$ A. For 1.5 s $< t$, $i_{sc} = 3$ A and $R_t = 8 \Omega$ so $\tau = \frac{12}{8} = 1.5$ s.

Therefore

$$i(t) = i_{sc} + (i(1.5) - i_{sc}) e^{-(t-1.5)/\tau} = 3 - 0.53 e^{-0.667(t-1.5)} \text{ V for } 1.5 \text{ s} < t$$

Finally

$$i(t) = \begin{cases} 2 + e^{-0.5t} \text{ A} & \text{for } 0 < t < 1.5 \text{ s} \\ 3 - 0.53 e^{-0.667(t-1.5)} \text{ A} & \text{for } 1.5 \text{ s} < t \end{cases}$$

P8.4-3

At $t = 0^-$:

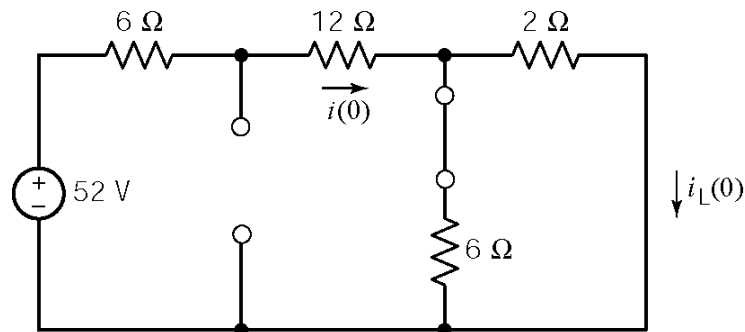

$$\text{KVL: } -52 + 18i + (12/8)i = 0$$

$$\Rightarrow i(0^-) = 104/39 \text{ A}$$

$$\therefore i_L = i \left(\frac{6}{6+2} \right) = \underline{2 \text{ A} = i_L(0^+)}$$

For $0 < t < 0.051$ s

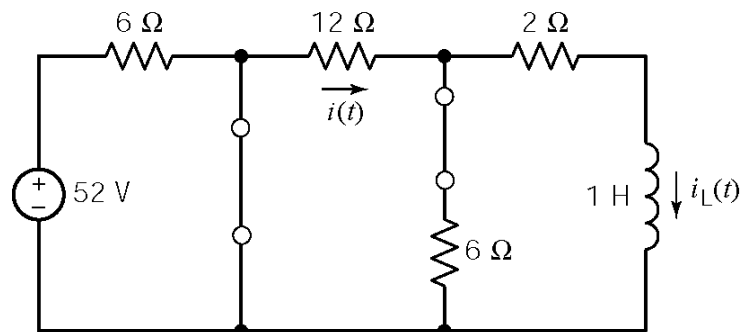

$$i_L(t) = i_L(0) e^{-t/\tau} \text{ where } \tau = L/R_t$$

$$R_t = 6 \parallel 12 + 2 = 6 \Omega$$

$$i_L(t) = 2 e^{-6t} \text{ A}$$

$$\therefore i(t) = i_L(t) \left(\frac{6+12}{6} \right) = \underline{6 e^{-6t} \text{ A}}$$

For $t > 0.051$ s

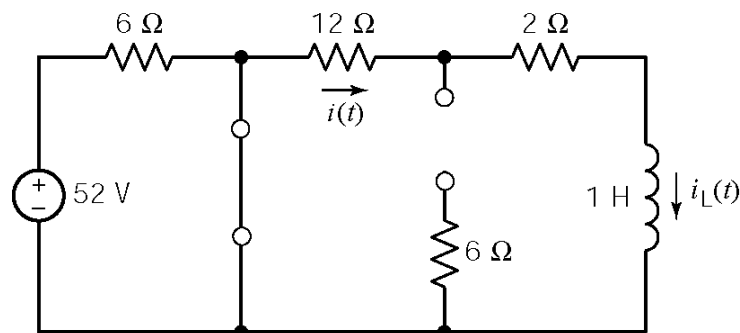

$$i_L(t) = i_L(0.051) e^{-(R/L)(t-0.051)}$$

$$i_L(0.051) = 2 e^{-6(0.051)} = 1.473 \text{ A}$$

$$i_L(t) = 1.473 e^{-14(t-0.051)} \text{ A}$$

$$i(t) = i_L(t) = 1.473 e^{-14(t-0.051)} \text{ A}$$

P8.4-4

At $t = 0^-$: Assume that the circuit has reached steady state so that the voltage across the $100 \mu\text{F}$ capacitor is 3 V . The charge stored by the capacitor is

$$q(0^-) = (100 \times 10^{-6})(3) = 300 \times 10^{-6} \text{ C}$$

$0 < t < 10\text{ms}$: With R negligibly small, the circuit reaches steady state almost immediately (i.e. at $t = 0^+$). The voltage across the parallel capacitors is determined by considering charge conservation:

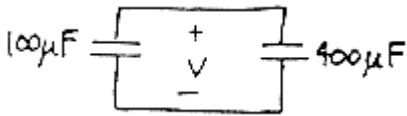

$$q(0^+) = (100 \mu\text{F}) v(0^+) + (400 \mu\text{F}) v(0^+)$$

$$v(0^+) = \frac{q(0^-)}{100 \times 10^{-6} + 400 \times 10^{-6}} = \frac{q(0^-)}{500 \times 10^{-6}} = \frac{300 \times 10^{-6}}{500 \times 10^{-6}}$$

$$v(0^+) = 0.6 \text{ V}$$

$10 \text{ ms} < t < 1 \text{ s}$: Combine $100 \mu\text{F}$ & $400 \mu\text{F}$ in parallel to obtain



$$v(t) = v(0^+) e^{-(t-0.01)/RC}$$

$$= 0.6 e^{-(t-0.01)/(10^3)(5 \times 10^{-4})}$$

$$v(t) = 0.6 e^{-2(t-0.01)} \text{ V}$$

P8.4-5

For $t < 0$:

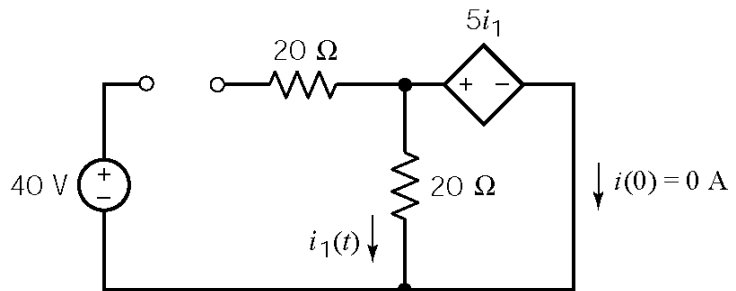

Find the Thevenin equivalent of the circuit connected to the inductor (after $t > 0$). First, the open circuit voltage:

$$i_1 = \frac{40}{20 + 20} = 1 \text{ A}$$

$$v_{oc} = 20 i_1 - 5 i_1 = 15 \text{ V}$$

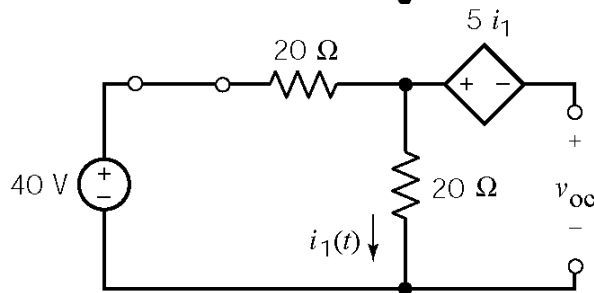

Next, the short circuit current:

$$20 i_1 = 5 i_1 \Rightarrow i_1 = 0$$

$$i_{sc} + 0 = \frac{40}{20} \Rightarrow i_{sc} = 2 \text{ A}$$

Then

$$R_t = \frac{v_{oc}}{i_{sc}} = \frac{15}{2} = 7.5 \text{ } \Omega$$

Replace the circuit connected to the inductor by its Norton equivalent circuit. First

$$\tau = \frac{L}{R_t} = \frac{15 \times 10^{-3}}{7.5} = \frac{1}{500}$$

Next

$$i(t) = 2 - 2 e^{-500t} \text{ A} \quad t > 0$$

After $t = 0$, the steady state inductor current is 2 A. 99% of 2 is 1.98.

$$1.98 = 2 - 2 e^{-500t} \Rightarrow t = \underline{9.2 \text{ ms}}$$

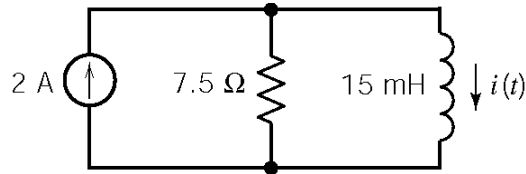
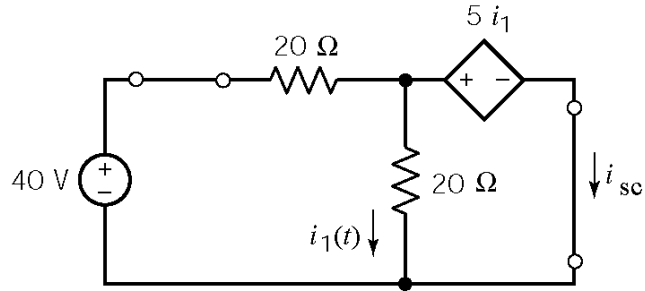

P8.4-6

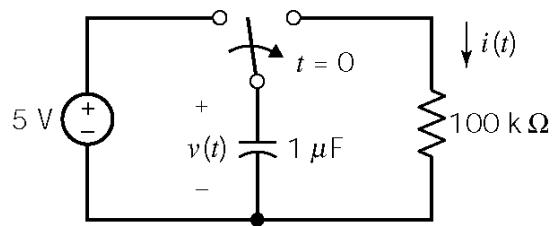

$$v(0) = 5 \text{ V}, \quad v(\infty) = 0 \quad \text{and} \quad \tau = 10^5 \times 10^{-6} = 0.1 \text{ s}$$

$$\therefore v(t) = 5 e^{-10t} \text{ V for } t > 0$$

$$2.5 = 5 e^{-10t_1} \quad \underline{t_1 = 0.0693 \text{ s}}$$

$$i(t_1) = \frac{v(t_1)}{100 \times 10^3} = \frac{2.5}{100 \times 10^3} = \underline{25 \text{ } \mu\text{A}}$$

Section 8-5: Stability of First Order Circuits

P8.5-1

This circuit will be stable if the Thévenin equivalent resistance of the circuit connected to the inductor is positive. The Thévenin equivalent resistance of the circuit connected to the inductor is calculated as

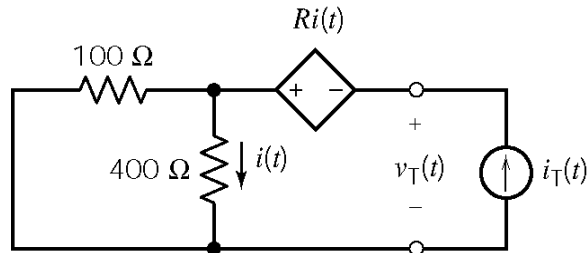

$$\left. \begin{aligned} i(t) &= \frac{100}{100+400} i_T \\ v_T &= 400 i(t) - R i(t) \end{aligned} \right\} \Rightarrow R_t = \frac{v_T}{i_T} = \frac{(400-R)100}{100+400}$$

The circuit is stable when $R < 400 \Omega$.

P8.5-2

The Thévenin equivalent resistance of the circuit connected to the inductor is calculated as

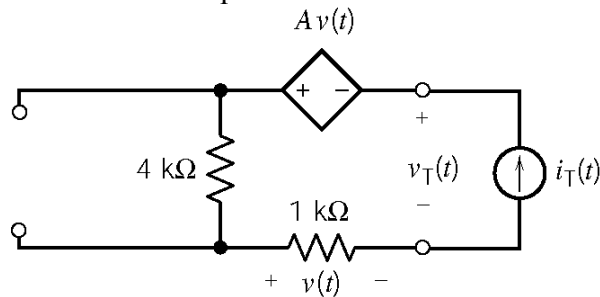

Ohm's law: $v(t) = 1000 i_T(t)$

KVL: $A v(t) + v_T(t) - v(t) - 4000 i_T(t) = 0$

$\therefore v_T(t) = (1-A)1000 i_T(t) + 4000 i_T(t)$

$$R_t = \frac{v_T(t)}{i_T(t)} = (5-A) \times 1000$$

The circuit is stable when $A < 5 \text{ V/V}$.

P8.5-3

The Thévenin equivalent resistance of the circuit connected to the inductor is calculated as

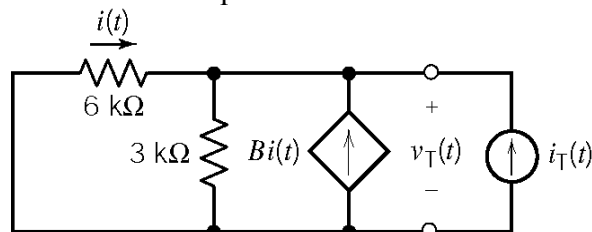

Ohm's law: $i(t) = -\frac{v_T(t)}{6000}$

KCL: $i(t) + B i(t) + i_T(t) = \frac{v_T(t)}{3000}$

$$\therefore i_T(t) = -(B+1) \left(-\frac{v_T(t)}{6000} \right) + \frac{v_T(t)}{3000}$$

$$= \frac{(B+3)v_T(t)}{6000}$$

$$R_t = \frac{v_T(t)}{i_T(t)} = \frac{6000}{B+3}$$

The circuit is stable when $B > -3 \text{ A/A}$.

P8.5-4

The Thévenin equivalent resistance of the circuit connected to the inductor is calculated as

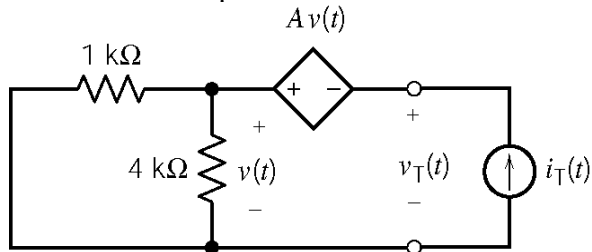

$$v(t) = \frac{(1000)(4000)}{1000 + 4000} i_T(t) = 800 i_T(t)$$

$$v_T(t) = v(t) - Av(t) = (1 - A) v(t)$$

$$R_t = \frac{v_T(t)}{i_T(t)} = 800 (1 - A)$$

The circuit is stable when $A < 1$ V/V.

Section 8-6: The Unit Step Response

P8.6-1

The value of the input is one constant, 8 V, before time $t = 0$ and a different constant, -7 V, after time $t = 0$. The response of the first order circuit to the change in the value of the input will be

$$v_o(t) = A + B e^{-at} \quad \text{for } t > 0$$

where the values of the three constants A , B and a are to be determined.

The values of A and B are determined from the steady state responses of this circuit before and after the input changes value.

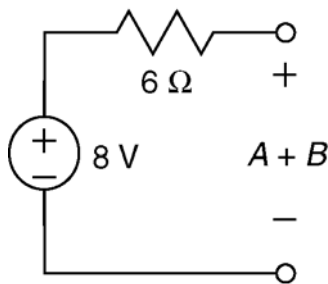

The steady-state circuit for $t < 0$.

Capacitors act like open circuits when the input is constant and the circuit is at steady state. Consequently, the capacitor is replaced by an open circuit.

The value of the capacitor voltage at time $t = 0$, will be equal to the steady state capacitor voltage before the input changes. At time $t = 0$ the output voltage is

$$v_o(0) = A + B e^{-a(0)} = A + B$$

Consequently, the capacitor voltage is labeled as $A + B$. Analysis of the circuit gives

$$A + B = 8 \text{ V}$$

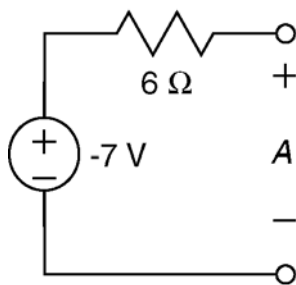

The steady-state circuit for $t > 0$.

Capacitors act like open circuits when the input is constant and the circuit is at steady state. Consequently, the capacitor is replaced by an open circuit.

The value of the capacitor voltage at time $t = \infty$, will be equal to the steady state capacitor voltage after the input changes. At time $t = \infty$ the output voltage is

$$v_o(\infty) = A + B e^{-a(\infty)} = A$$

Consequently, the capacitor voltage is labeled as A . Analysis of the circuit gives

$$A = -7 \text{ V}$$

Therefore

$$B = 15 \text{ V}$$

The value of the constant a is determined from the time constant, τ , which is in turn calculated from the values of the capacitance C and of the Thevenin resistance, R_t , of the circuit connected to the capacitor.

$$\frac{1}{a} = \tau = R_t C$$

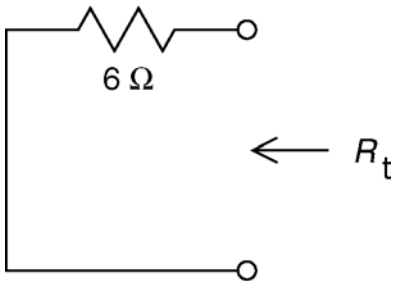

Here is the circuit used to calculate R_t .

$$R_t = 6 \Omega$$

Therefore

$$a = \frac{1}{(6)(66.7 \times 10^{-3})} = 2.5 \frac{1}{s}$$

(The time constant is $\tau = (6)(66.7 \times 10^{-3}) = 0.4 \text{ s.}$)

Putting it all together:

$$v_o(t) = \begin{cases} 8 \text{ V} & \text{for } t \leq 0 \\ -7 + 15 e^{-2.5t} \text{ V} & \text{for } t \geq 0 \end{cases}$$

P8.6-2

The value of the input is one constant, 3 V, before time $t = 0$ and a different constant, 6 V, after time $t = 0$. The response of the first order circuit to the change in the value of the input will be

$$v_o(t) = A + B e^{-at} \quad \text{for } t > 0$$

where the values of the three constants A , B and a are to be determined.

The values of A and B are determined from the steady state responses of this circuit before and after the input changes value.

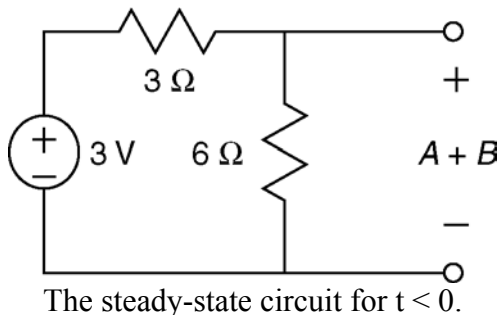

Capacitors act like open circuits when the input is constant and the circuit is at steady state. Consequently, the capacitor is replaced by an open circuit.

The value of the capacitor voltage at time $t = 0$, will be equal to the steady state capacitor voltage before the input changes. At time $t = 0$ the output voltage is

$$v_o(0) = A + B e^{-a(0)} = A + B$$

Consequently, the capacitor voltage is labeled as $A + B$. Analysis of the circuit gives

$$A + B = \frac{6}{3+6}(3) = 2 \text{ V}$$

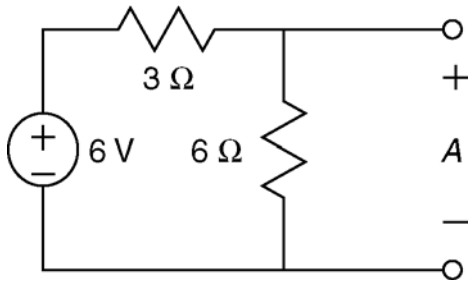

The steady-state circuit for $t > 0$.

Capacitors act like open circuits when the input is constant and the circuit is at steady state. Consequently, the capacitor is replaced by an open circuit.

The value of the capacitor voltage at time $t = \infty$, will be equal to the steady state capacitor voltage after the input changes. At time $t = \infty$ the output voltage is

$$v_o(\infty) = A + B e^{-a(\infty)} = A$$

Consequently, the capacitor voltage is labeled as A . Analysis of the circuit gives

$$A = \frac{6}{3+6}(6) = 4 \text{ V}$$

Therefore

$$B = -2 \text{ V}$$

The value of the constant a is determined from the time constant, τ , which is in turn calculated from the values of the capacitance C and of the Thevenin resistance, R_t , of the circuit connected to the capacitor.

$$\frac{1}{a} = \tau = R_t C$$

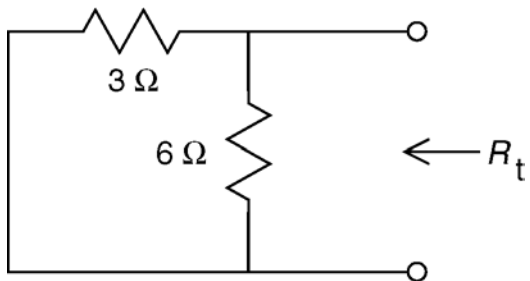

Here is the circuit used to calculate R_t .

$$R_t = \frac{(3)(6)}{3+6} = 2 \text{ } \Omega$$

Therefore

$$a = \frac{1}{(2)(.5)} = 1 \text{ } \frac{1}{\text{s}}$$

(The time constant is $\tau = (2)(0.5) = 1 \text{ s.}$)

Putting it all together:

$$v_o(t) = \begin{cases} 2 \text{ V} & \text{for } t \leq 0 \\ 4 - 2 e^{-t} \text{ V} & \text{for } t \geq 0 \end{cases}$$

P8.6-3

The value of the input is one constant, -7 V , before time $t = 0$ and a different constant, 6 V , after time $t = 0$. The response of the first order circuit to the change in the value of the input will be

$$v_o(t) = A + B e^{-at} \quad \text{for } t > 0$$

where the values of the three constants A , B and a are to be determined.

The values of A and B are determined from the steady state responses of this circuit before and after the input changes value.

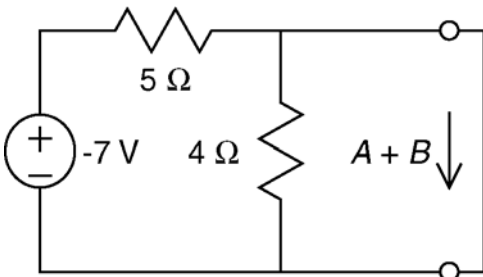

The steady-state circuit for $t < 0$.

Inductors act like short circuits when the input is constant and the circuit is at steady state. Consequently, the inductor is replaced by a short circuit.

The value of the inductor current at time $t = 0$, will be equal to the steady state inductor current before the input changes. At time $t = 0$ the output current is

$$i_o(0) = A + B e^{-a(0)} = A + B$$

Consequently, the inductor current is labeled as $A + B$. Analysis of the circuit gives

$$A + B = \frac{-7}{5} = -1.4\text{ A}$$

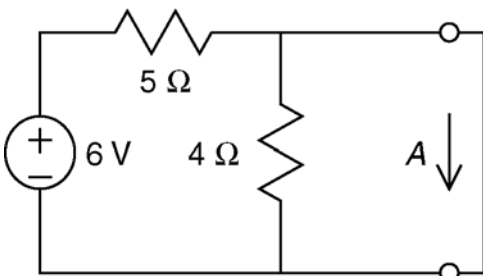

The steady-state circuit for $t > 0$.

Inductors act like short circuits when the input is constant and the circuit is at steady state. Consequently, the inductor is replaced by a short circuit.

The value of the inductor current at time $t = \infty$, will be equal to the steady state inductor current after the input changes. At time $t = \infty$ the output current is

$$i_o(\infty) = A + B e^{-a(\infty)} = A$$

Consequently, the inductor current is labeled as A . Analysis of the circuit gives

$$A = \frac{6}{5} = 1.2\text{ A}$$

Therefore

$$B = -2.6\text{ V}$$

The value of the constant a is determined from the time constant, τ , which is in turn calculated from the values of the inductance L and of the Thevenin resistance, R_t , of the circuit connected to the inductor.

$$\frac{1}{a} = \tau = \frac{L}{R_t}$$

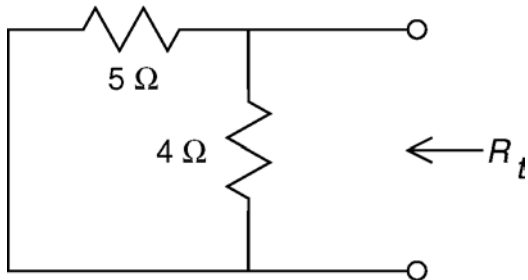

Here is the circuit used to calculate R_t .

$$R_t = \frac{(5)(4)}{5+4} = 2.22 \text{ } \Omega$$

Therefore

$$a = \frac{2.22}{1.2} = 1.85 \text{ } \frac{1}{\text{s}}$$

$$\text{(The time constant is } \tau = \frac{1.2}{2.22} = 0.54 \text{ s.)}$$

Putting it all together:

$$i_o(t) = \begin{cases} -1.4 \text{ A} & \text{for } t \leq 0 \\ 1.2 - 2.6 e^{-1.85t} \text{ A} & \text{for } t \geq 0 \end{cases}$$

P8.6-4

$$v(t) = 4u(t) - u(t-1) - u(t-2) + u(t-4) - u(t-6)$$

P8.6-5

$$v_s(t) = \begin{cases} 0 & t < 1 \\ 4 & 1 < t < 2 \\ 0 & t > 2 \end{cases}$$

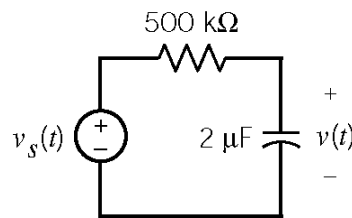

Assume that the circuit is at steady state at $t = 1^-$. Then

$$v(t) = 4 - 4e^{-(t-1)} \text{ V for } 1 \leq t \leq 2$$

$$\text{so } v(2) = 4 - 4e^{-(2-1)} = 2.53 \text{ V}$$

$$\tau = RC = (5 \times 10^5)(2 \times 10^{-6}) = 1 \text{ s and}$$

$$v(t) = 2.53 e^{-(t-2)} \text{ V for } t \geq 2$$

$$\therefore v(t) = \begin{cases} 0 & t \leq 1 \\ 4 - 4e^{-(t-1)} & 1 \leq t \leq 2 \\ 2.53e^{-(t-2)} & t \geq 2 \end{cases}$$

P8.6-6

The capacitor voltage is $v(0^-) = 10$ V immediately before the switch opens at $t = 0$.

For $0 < t < 0.5$ s the switch is open:

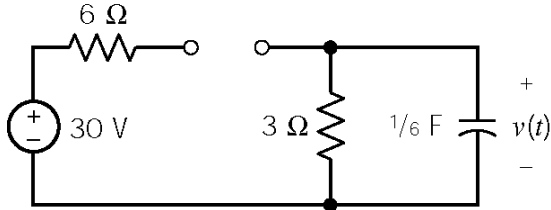

$$v(0) = 10 \text{ V}, \quad v(\infty) = 0 \text{ V}, \quad \tau = 3 \times \frac{1}{6} = \frac{1}{2} \text{ s}$$

$$\text{so } v(t) = 10 e^{-2t} \text{ V}$$

$$\text{In particular, } v(0.5) = 10 e^{-2(0.5)} = 3.679 \text{ V}$$

For $t > 0.5$ s the switch is closed:

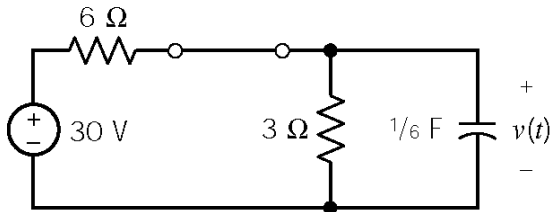

$$v(0) = 3.679 \text{ V}, \quad v(\infty) = 10 \text{ V}, \quad R_t = 6 \parallel 3 = 2 \text{ } \Omega,$$

$$\tau = 2 \times \frac{1}{6} = \frac{1}{3} \text{ s}$$

so

$$v(t) = 10 + (3.679 - 10)e^{-3(t-0.5)} \text{ V}$$

$$= 10 - 6.321 e^{-3(t-0.5)} \text{ V}$$

P8.6-7

Assume that the circuit is at steady state before $t = 0$. Then the initial inductor current is $i(0^-) = 0$ A.

For $0 < t < 1$ ms:

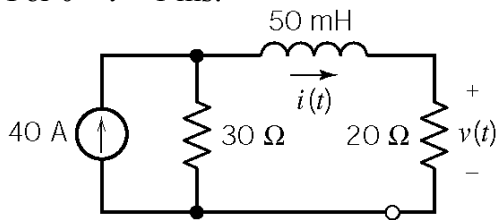

The steady state inductor current will be

$$i(\infty) = \lim_{t \rightarrow \infty} i(t) = \frac{30}{30+20}(40) = 24 \text{ A}$$

The time constant will be

$$\tau = \frac{50 \times 10^{-3}}{30+20} = 10^{-3} = \frac{1}{1000} \text{ s}$$

The inductor current is $i(t) = 24(1 - e^{-1000t})$ A

In particular, $i(0.001) = 24(1 - e^{-1}) = 15.2$ A

For $t > 1$ ms

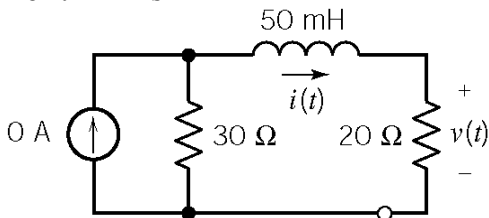

Now the initial current is $i(0.001) = 15.2$ A and the steady state current is 0 A. As before, the time constant is 1 ms. The inductor current is

$$i(t) = 15.2 e^{-1000(t-0.001)} \text{ A}$$

The output voltage is

$$v(t) = 20 i(t) = \begin{cases} 480(1 - e^{-1000t}) & \text{V } t < 1 \text{ ms} \\ 303 e^{-1000(t-0.001)} & \text{V } t > 1 \text{ ms} \end{cases}$$

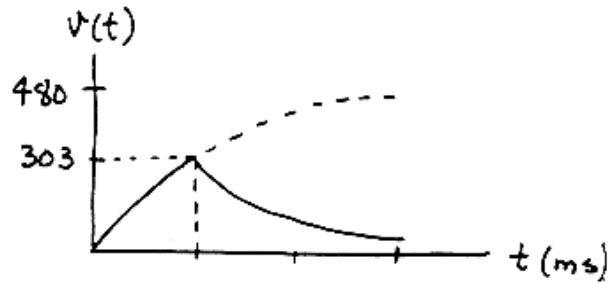

P8.6-8

For $t < 0$, the circuit is:

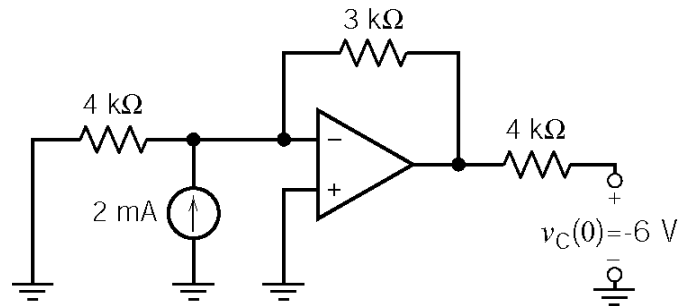

After $t = 0$, replace the part of the circuit connected to the capacitor by its Thevenin equivalent circuit to get:

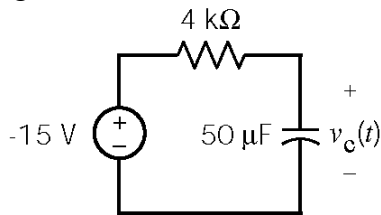

$$\begin{aligned} v_c(t) &= -15 + (-6 - (-15)) e^{-t/(4000 \times 0.00005)} \\ &= -15 + 9 e^{-5t} \text{ V} \end{aligned}$$

Section 8-7 The Response of an RL or RC Circuit to a Nonconstant Source

P8.7-1

Assume that the circuit is at steady state before $t = 0$:

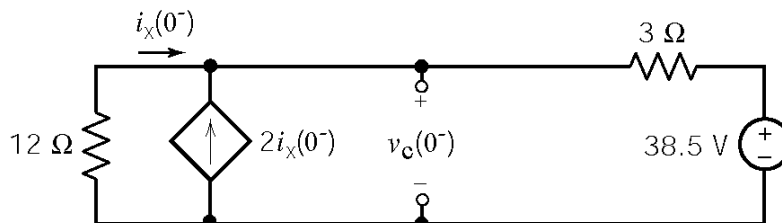

$$\text{KVL} : 12i_x + 3(3i_x) + 38.5 = 0 \Rightarrow i_x = -1.83 \bar{\text{A}}$$

$$\text{Then } \underline{v_c(0^-) = -12i_x = 22 \text{ V} = v_c(0^+)}$$

After $t = 0$:

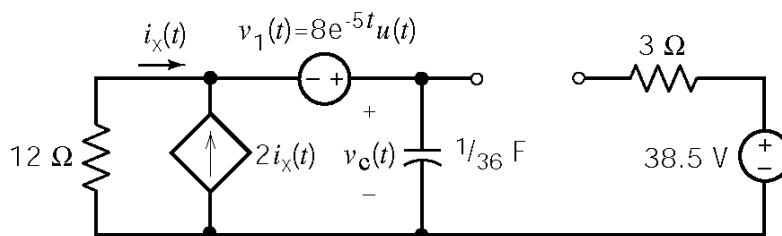

$$\text{KVL} : 12i_x(t) - 8e^{-5t} + v_c(t) = 0$$

$$\text{KCL} : -i_x(t) - 2i_x(t) + (1/36) \frac{dv_c(t)}{dt} = 0 \Rightarrow i_x(t) = \frac{1}{108} \frac{dv_c(t)}{dt}$$

$$\therefore 12 \left[\frac{1}{108} \frac{dv_c(t)}{dt} \right] - 8e^{-5t} + v_c(t) = 0$$

$$\frac{dv_c(t)}{dt} + 9v_c(t) = 72e^{-5t} \Rightarrow v_{cn}(t) = Ae^{-9t}$$

Try $v_{cf}(t) = Be^{-5t}$ & substitute into the differential equation $\Rightarrow B = 18$

$$\therefore v_c(t) = Ae^{-9t} + 18e^{-5t}$$

$$v_c(0) = 22 = A + 18 \Rightarrow A = 4$$

$$\therefore \underline{v_c(t) = 4e^{-9t} + 18e^{-5t} \text{ V}}$$

P8.7-2

Assume that the circuit is at steady state before $t = 0$:

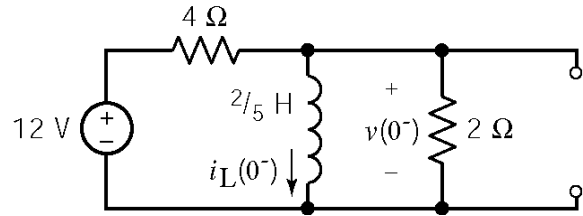

$$i_L(0^+) = i_L(0^-) = \frac{12}{4} = 3 \text{ A}$$

After $t = 0$:

$$\text{KCL: } \frac{v(t)-12}{4} + i_L(t) + \frac{v(t)}{2} = 6e^{-2t}$$

$$\text{also: } v(t) = (2/5) \frac{di_L(t)}{dt}$$

$$i_L(t) + \frac{3}{4} \left[(2/5) \frac{di_L(t)}{dt} \right] = 3 + 6e^{-2t}$$

$$\frac{di_L(t)}{dt} + \frac{10}{3} i_L(t) = 10 + 20e^{-2t}$$

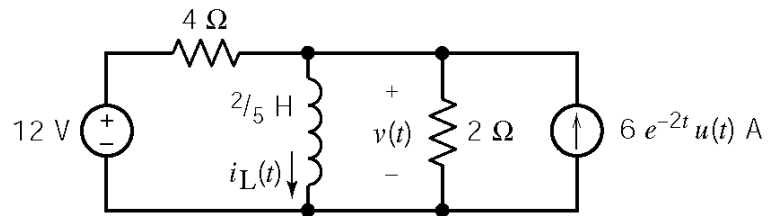

$\therefore i_n(t) = Ae^{-(10/3)t}$, try $i_f(t) = B + Ce^{-2t}$, substitute into the differential equation,

and then equating like terms $\Rightarrow B=3, C=15 \Rightarrow i_f(t)=3+15e^{-2t}$

$\therefore i_L(t) = i_n(t) + i_f(t) = Ae^{-(10/3)t} + 3 + 15e^{-2t}$, $i_L(0) = 3 = A + 3 + 15 \Rightarrow A = -15$

$$\therefore i_L(t) = -15e^{-(10/3)t} + 3 + 15e^{-2t}$$

Finally, $v(t) = (2/5) \frac{di_L}{dt} = 20e^{-(10/3)t} - 12e^{-2t} \text{ V}$

P8.7-3

Assume that the circuit is at steady state before $t = 0$:

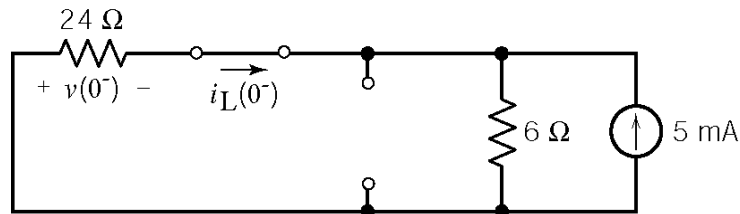

Current division: $i_L(0^-) = -5 \left(\frac{6}{6+24} \right) = -1 \text{ mA}$

After $t = 0$:

$$\text{KVL: } -25 \sin 4000 t + 24i_L(t) + .008 \frac{di_L(t)}{dt} = 0$$

$$\frac{di_L(t)}{dt} + 3000i_L(t) = \frac{25}{.008} \sin 4000t$$

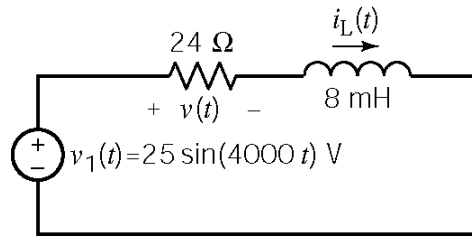

$i_n(t) = Ae^{-3000t}$, try $i_f(t) = B \cos 4000t + C \sin 4000t$, substitute into the differential equation and equate like terms $\Rightarrow B = -1/2, C = 3/8 \Rightarrow i_f(t) = -0.5 \cos 4000t + 0.375 \sin 4000t$

$$i_L(t) = i_n(t) + i_f(t) = Ae^{-3000t} - 0.5 \cos 4000t + 0.375 \sin 4000t$$

$$i_L(0^+) = i_L(0^-) = -10^{-3} = A - 0.5 \Rightarrow A \cong 0.5$$

$$\therefore i_L(t) = 0.5 e^{-3000t} - 0.5 \cos 4000t + 0.375 \sin 4000t \text{ mA}$$

$$\text{but } v(t) = 24i_L(t) = 12 e^{-3000t} - 12 \cos 4000t + 9 \sin 4000t \text{ V}$$

P8.7-4

Assume that the circuit is at steady state before $t = 0$:

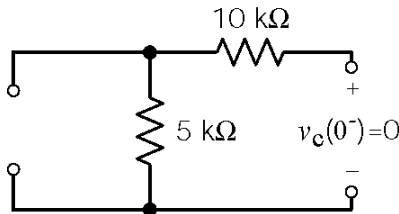

Replace the circuit connected to the capacitor by its Thevenin equivalent (after $t=0$) to get:

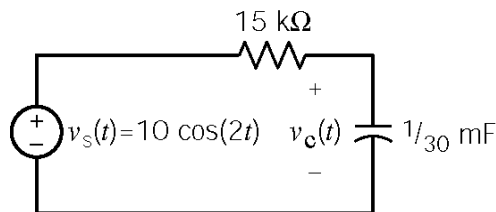

$$\text{KVL: } -10 \cos 2t + 15 \left(\frac{1}{30} \frac{dv_c(t)}{dt} \right) + v_c(t) = 0 \Rightarrow \frac{dv_c(t)}{dt} + 2v_c(t) = 20 \cos 2t$$

$v_n(t) = Ae^{-2t}$, Try $v_f(t) = B \cos 2t + C \sin 2t$ & substitute into the differential equation to get

$$B = C = 5 \Rightarrow v_f(t) = 5 \cos 2t + 5 \sin 2t. \therefore v_c(t) = v_n(t) + v_f(t) = Ae^{-2t} + 5 \cos 2t + 5 \sin 2t$$

$$\text{Now } v_c(0) = 0 = A + 5 \Rightarrow A = -5 \Rightarrow \underline{v_c(t) = -5e^{-2t} + 5 \cos 2t + 5 \sin 2t \text{ V}}$$

P8.7-5

Assume that the circuit is at steady state before $t = 0$. There are no sources in the circuit so $i(0) = 0$ A. After $t = 0$, we have:

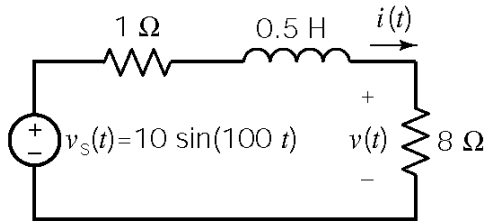

$$\text{KVL : } -10 \sin 100t + i(t) + 5 \frac{di(t)}{dt} + v(t) = 0$$

$$\text{Ohm's law : } i(t) = \frac{v(t)}{8}$$

$$\therefore \frac{dv(t)}{dt} + 18 v(t) = 160 \sin 100t$$

$\therefore v_n(t) = Ae^{-18t}$, try $v_f(t) = B \cos 100t + C \sin 100t$, substitute into the differential equation and equate like terms $\Rightarrow B = -1.55$ & $C = 0.279 \Rightarrow v_f(t) = -1.55 \cos 100t + 0.279 \sin 100t$

$$\therefore v(t) = v_n(t) + v_f(t) = Ae^{-18t} - 1.55 \cos 100t + 0.279 \sin 100t$$

$$v(0) = 8 i(0) = 0 \Rightarrow v(0) = 0 = A - 1.55 \Rightarrow A = 1.55$$

$$\text{so } \underline{v(t) = 1.55e^{-18t} - 1.55 \cos 100t + 0.279 \sin 100t \text{ V}}$$

P8.7-6

Assume that the circuit is at steady state before $t = 0$.

$$v_o(t) = -v_c(t)$$

$$v_c(0^+) = v_c(0^-) = -10 \text{ V}$$

After $t = 0$, we have

$$i(t) = \frac{v_s(t)}{15000} = \frac{8e^{-5t}}{15000} = 0.533 e^{-5t} \text{ mA}$$

The circuit is represented by the differential equation: $i(t) = C \frac{dv_c(t)}{dt} + \frac{v_c(t)}{R}$. Then

$$i(t) = C \frac{dv_c(t)}{dt} + \frac{v_c(t)}{R}$$

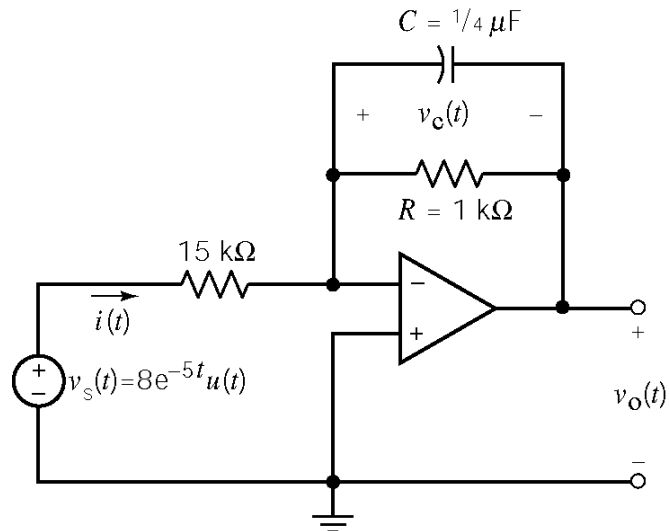

$$(0.533 \times 10^{-3}) e^{-5t} = (0.25 \times 10^{-6}) \frac{dv_c(t)}{dt} + (10^{-3}) v_c(t) \Rightarrow \frac{dv_c(t)}{dt} + 4000 v_c(t) = 4000 e^{-5t}$$

Then $v_n(t) = Ae^{-4000t}$. Try $v_f(t) = Be^{-5t}$. Substitute into the differential equation to get

$$\frac{d(Be^{-5t})}{dt} + 4000(Be^{-5t}) = 4000 e^{-5t} \Rightarrow B = \frac{4000}{-3995} = -1.00125 \cong -1$$

$$v_c(t) = v_f(t) + v_n(t) = e^{-5t} + Ae^{-4000t}$$

$$v_c(0) = -10 = 1 + A \Rightarrow A = -11 \Rightarrow v_c(t) = 1e^{-2t} - 11e^{-4000t} \text{ V}$$

Finally

$$\underline{v_o(t) = -v_c(t) = 11e^{-4000t} - 1e^{-5t} \text{ V}, t \geq 0}$$

P8.7-7

From the graph $i_L(t) = \frac{1}{4}t$ mA. Use KVL to get

$$(1)i_L(t) + 0.4 \frac{di_L(t)}{dt} = v_1(t) \Rightarrow \frac{di_L(t)}{dt} + 2.5 i_L(t) = 2.5 v_1(t)$$

Then

$$\frac{di}{dt} \left[\frac{1}{4}t \right] + 2.5 \left[\frac{1}{4}t \right] = 2.5 v_1(t) \Rightarrow \underline{v_1 = 0.1 + 0.25t \text{ V}}$$

P8.7-8

Assume that the circuit is at steady state before $t = 0$.

$$v(0^+) = v(0^-) = \frac{2}{4+2} 30 = 10 \text{ V}$$

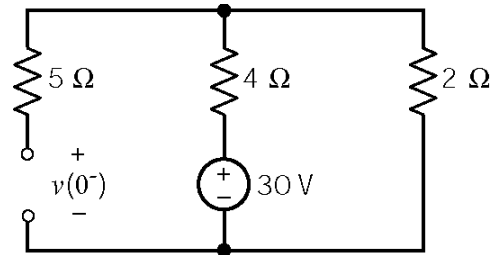

After $t = 0$ we have

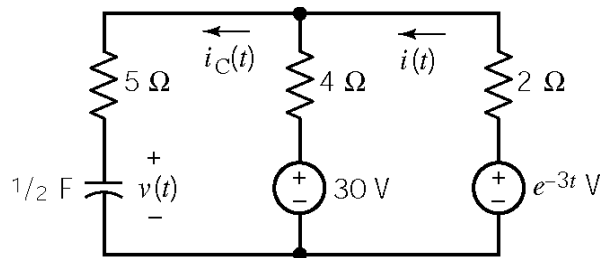

$$\text{KVL: } \frac{5}{2} \frac{dv(t)}{dt} + v(t) + 4 \left(\frac{1}{2} \frac{dv(t)}{dt} - i \right) = 30$$

$$2i(t) + 4 \left(i(t) - \frac{1}{2} \frac{dv(t)}{dt} \right) + 30 = e^{-3t}$$

The circuit is represented by the differential equation

$$\frac{dv(t)}{dt} + \frac{6}{19} v(t) = \frac{6}{19} \left(10 + \frac{2}{3} e^{-3t} \right)$$

Take $v_n(t) = Ae^{-(6/19)t}$. Try $v_f(t) = B + Ce^{-3t}$, substitute into the differential equation to get

$$-3Ce^{-3t} + \frac{6}{19}(B + Ce^{-3t}) = \frac{60}{19} + \frac{4}{19}e^{-3t}$$

Equate coefficients to get

$$B = 10, C = -\frac{4}{51} \Rightarrow v_f(t) = \frac{4}{51}e^{-3t} + Ae^{-(6/19)t}$$

Then

$$v(t) = v_n(t) + v_f(t) = 10 - \frac{4}{51}e^{-3t} + Ae^{-(6/19)t}$$

Finally

$$v_c(0^+) = 10 \text{ V}, \Rightarrow 10 = 10 - \frac{4}{51} + A \Rightarrow A = \frac{4}{51}$$

$$\therefore v_c(t) = 10 + \frac{4}{51}(e^{-(6/19)t} - e^{-3t}) \text{ V}$$

P8.7-9

We are given $v(0) = 0$. From part *b* of the figure:

$$v_s(t) = \begin{cases} 5t & 0 \leq t \leq 2 \text{ s} \\ 10 & t > 2 \text{ s} \end{cases}$$

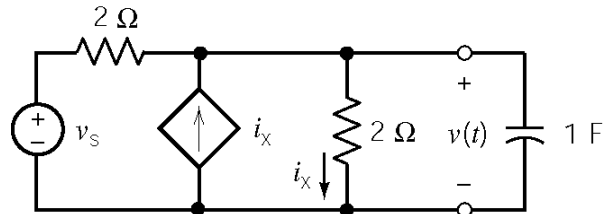

Find the Thevenin equivalent of the part of the circuit that is connected to the capacitor:

The open circuit voltage:

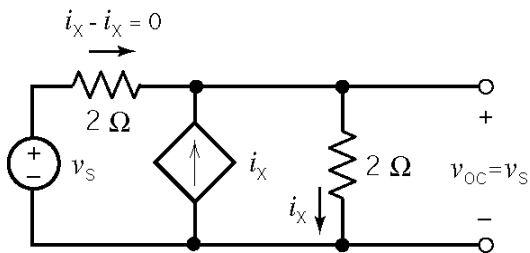

The short circuit current:

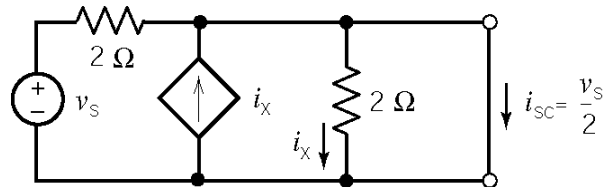

($i_x = 0$ because of the short across the right 2Ω resistor)

Replace the part of the circuit connected to the capacitor by its Thevenin equivalent:

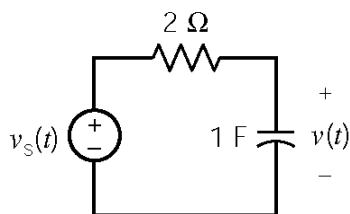

KVL:

$$2 \frac{dv(t)}{dt} + v(t) - v_s(t) = 0$$

$$\frac{dv(t)}{dt} + \frac{v(t)}{2} = \frac{v_s(t)}{2}$$

$$v_n(t) = Ae^{-0.5t}$$

For $0 < t < 2$ s, $v_s(t) = 5t$. Try $v_f(t) = B + Ct$. Substituting into the differential equation and equating coefficients gives $B = -10$ and $C = 5$. Therefore $v(t) = 5t - 10 + Ae^{-t/2}$. Using $v(0) = 0$, we determine that $A = 10$. Consequently, $v(t) = 5t + 10(e^{-t/2} - 1)$.

At $t = 2$ s, $v(2) = 10e^{-1} = 3.68$.

Next, for $t > 2$ s, $v_s(t) = 10$ V. Try $v_f(t) = B$. Substituting into the differential equation and equating coefficients gives $B = 10$. Therefore $v(t) = 10 + Ae^{-(t-2)/2}$. Using $v(2) = 3.68$, we determine that $A = -6.32$. Consequently, $v(t) = 10 - 6.32e^{-(t-2)/2}$.

P8.7-10

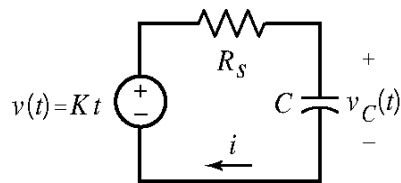

$$\begin{aligned} \text{KVL: } -kt + R_s \left[C \frac{dv_C(t)}{dt} \right] + v_C(t) &= 0 \\ \Rightarrow \frac{dv_C(t)}{dt} + \frac{1}{R_s C} v_C(t) &= \frac{k}{R_s C} t \end{aligned}$$

$v_c(t) = v_n(t) + v_f(t)$, where $v_c(t) = Ae^{-t/R_s C}$. Try $v_f(t) = B_0 + B_1 t$

& plug into D.E. $\Rightarrow B_1 + \frac{1}{R_s C} [B_0 + B_1 t] = \frac{k}{R_s C} t$ thus $B_0 = -kR_s C$, $B_1 = k$.

Now we have $v_c(t) = Ae^{-t/R_s C} + k(t - R_s C)$. Use $v_c(0) = 0$ to get $0 = A - kR_s C \Rightarrow A = kR_s C$.

$\therefore v_c(t) = k[t - R_s C(1 - e^{-t/R_s C})]$. Plugging in $k=1000$, $R_s = 625$ k Ω & $C=2000$ pF get

$$\underline{v_c(t) = 1000[t - 1.25 \times 10^{-3}(1 - e^{-800t})]}$$

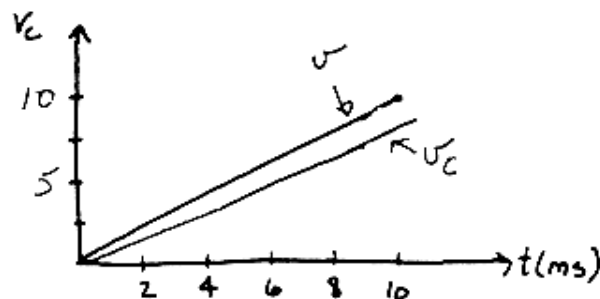

$v(t)$ and $v_C(t)$ track well on a millisecond time scale.

Spice Problems

SP 8-1

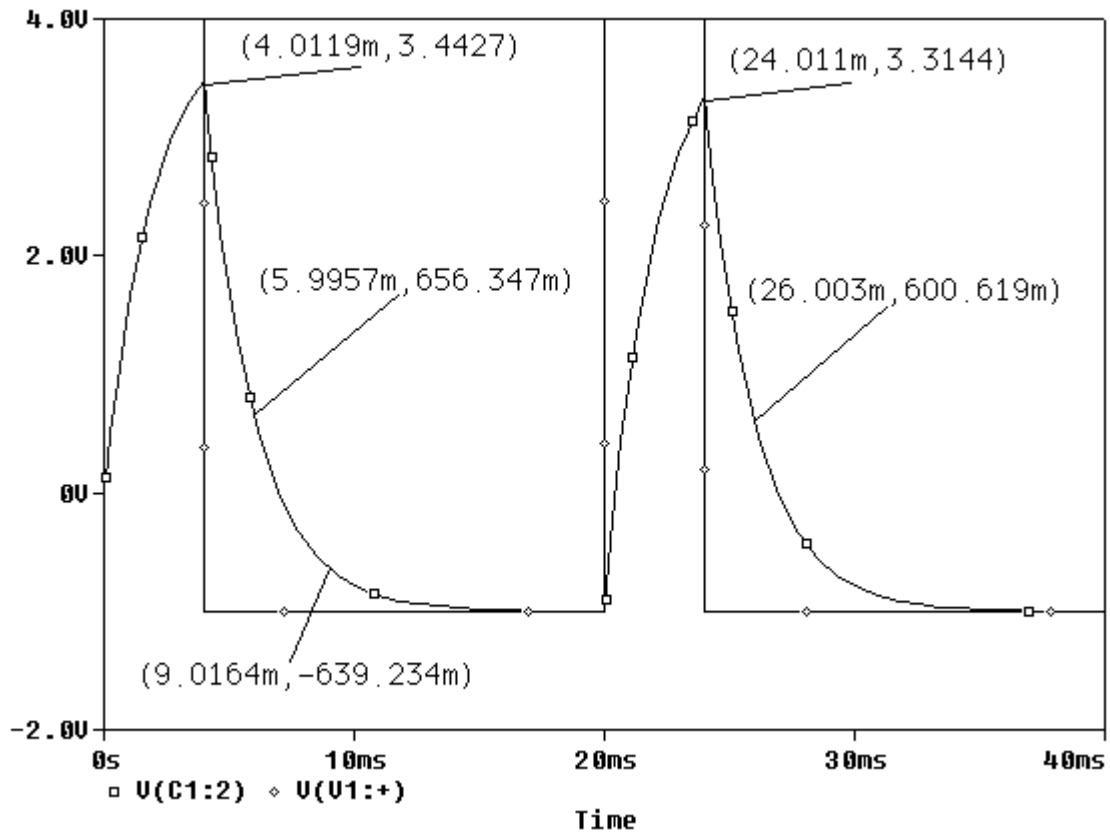
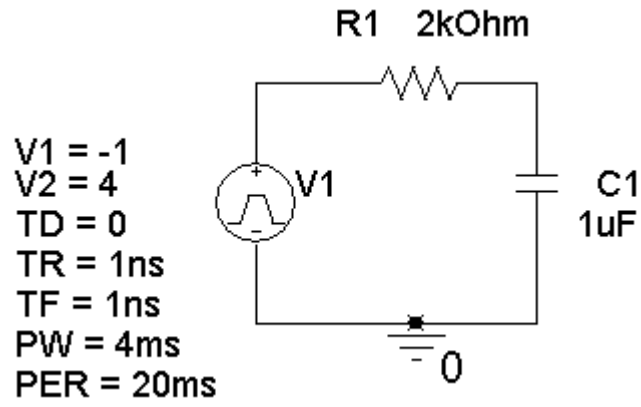

SP 8-2

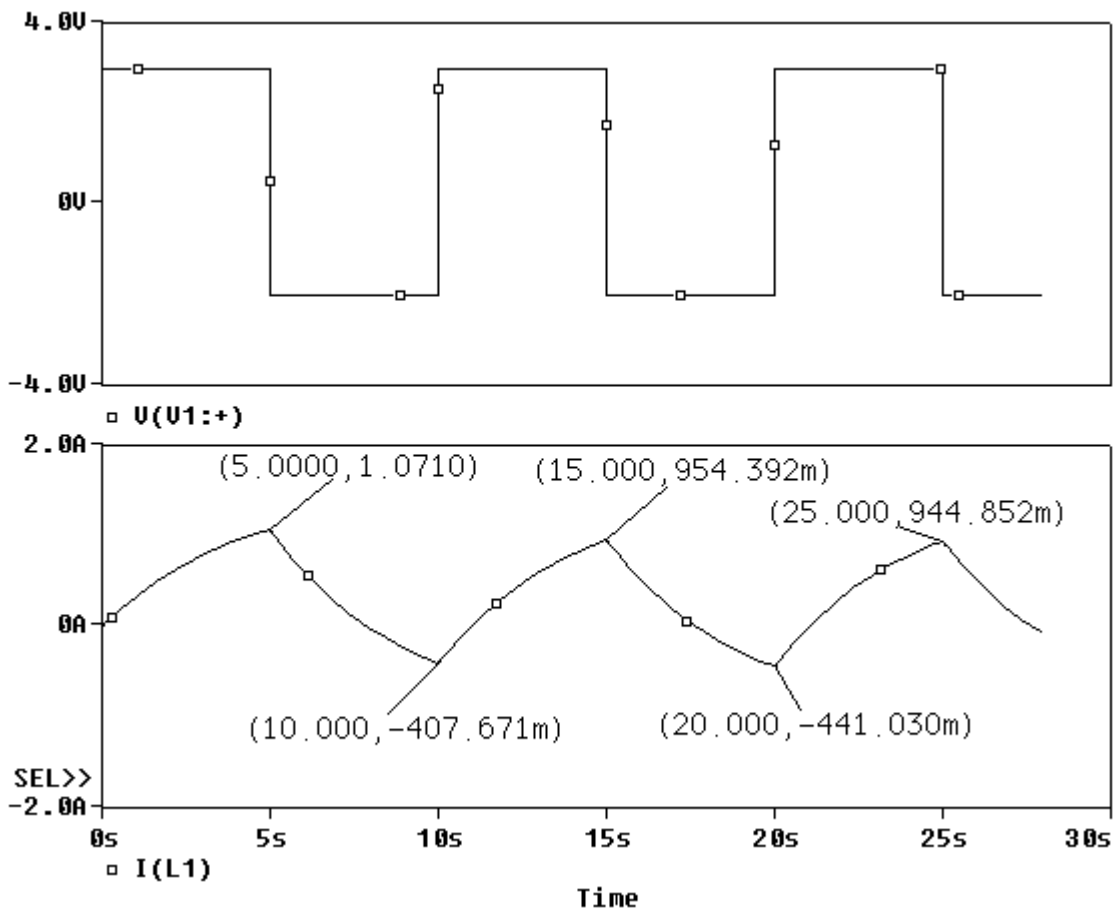
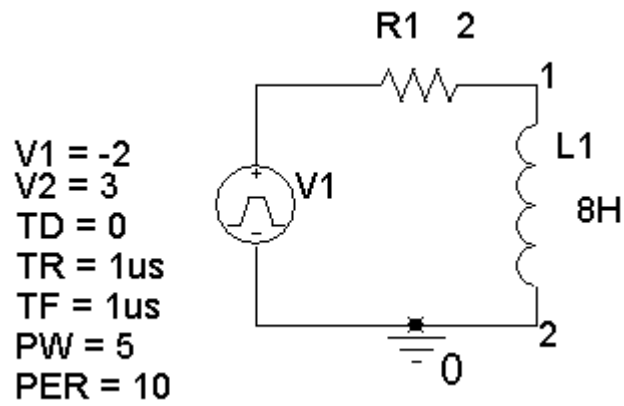

SP 8-3

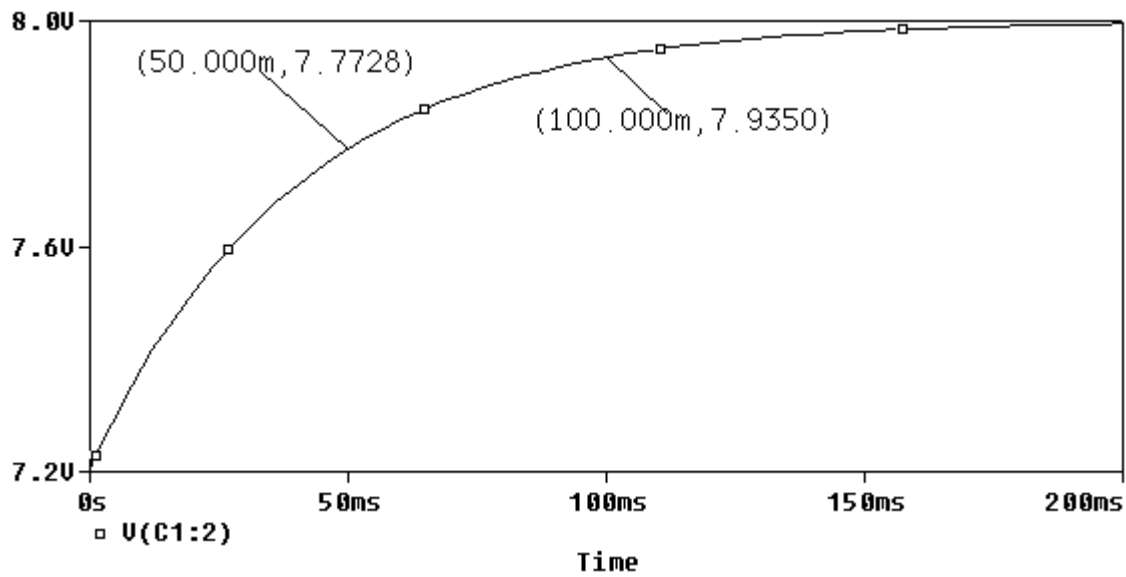
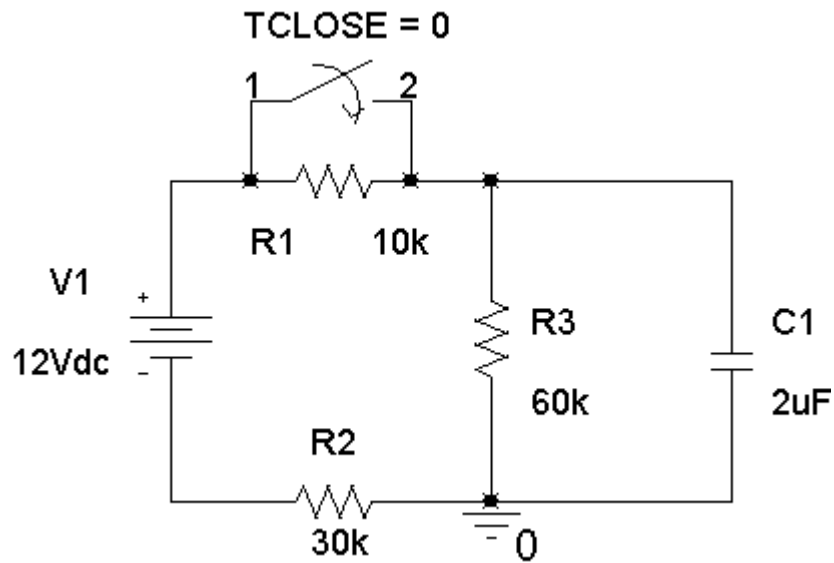

$$v(t) = A + B e^{-t/\tau} \quad \text{for } t > 0$$

$$\left. \begin{aligned} 7.2 = v(0) = A + B e^0 &\Rightarrow 7.2 = A + B \\ 8.0 = v(\infty) = A + B e^{-\infty} &\Rightarrow A = 8.0 \text{ V} \end{aligned} \right\} \Rightarrow B = -0.8 \text{ V}$$

$$7.7728 = v(0.05) = 8 - 0.8 e^{-0.05/\tau} \Rightarrow -\frac{0.05}{\tau} = \ln\left(\frac{8 - 7.7728}{0.8}\right) = -1.25878$$

$$\Rightarrow \tau = \frac{0.05}{1.25878} = 39.72 \text{ ms}$$

Therefore

$$v(t) = 8 - 0.8 e^{-t/0.03972} \text{ V for } t > 0$$

SP 8-4

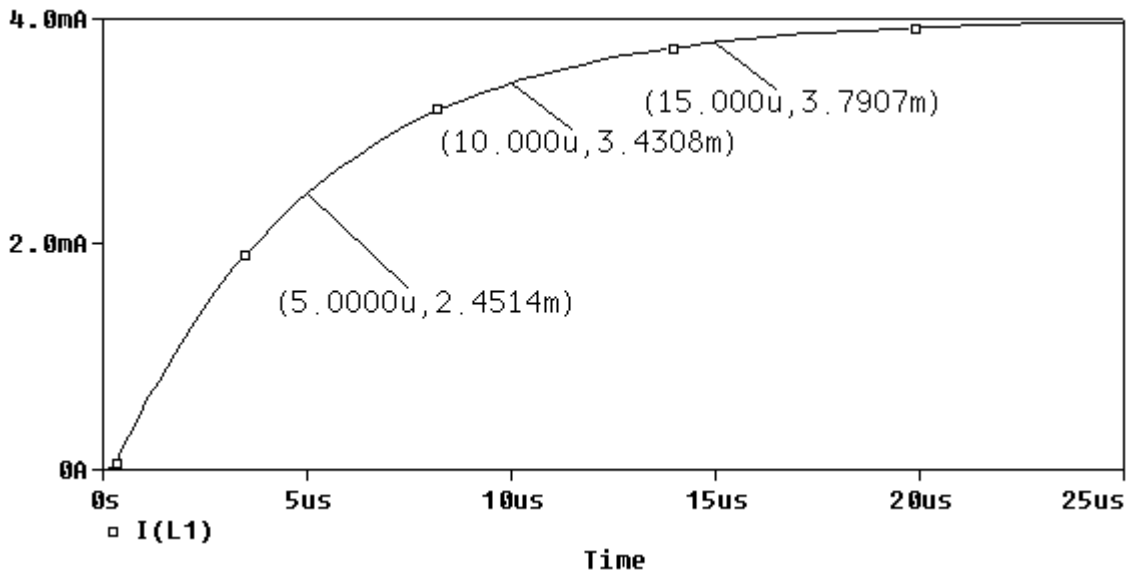
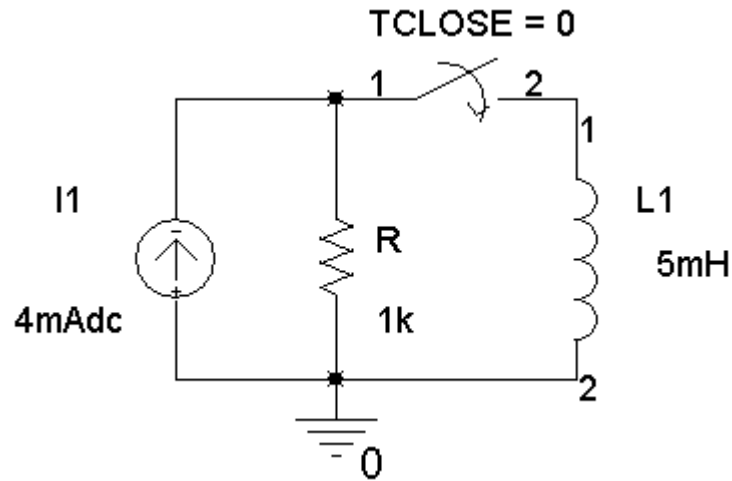

$$i(t) = A + B e^{-t/\tau} \quad \text{for } t > 0$$

$$\left. \begin{aligned} 0 = i(0) = A + B e^0 &\Rightarrow 0 = A + B \\ 4 \times 10^{-3} = i(\infty) = A + B e^{-\infty} &\Rightarrow A = 4 \times 10^{-3} \text{ A} \end{aligned} \right\} \Rightarrow B = -4 \times 10^{-3} \text{ A}$$

$$2.4514 \times 10^{-3} = v(5 \times 10^{-6}) = (4 \times 10^{-3}) - (4 \times 10^{-3}) e^{-(5 \times 10^{-6})/\tau}$$

$$\Rightarrow -\frac{5 \times 10^{-6}}{\tau} = \ln\left(\frac{(4 - 2.4514) \times 10^{-3}}{4 \times 10^{-3}}\right) = -0.94894$$

$$\Rightarrow \tau = \frac{5 \times 10^{-6}}{0.94894} = 5.269 \mu\text{s}$$

Therefore

$$i(t) = 4 - 4 e^{-t/5.269 \times 10^{-6}} \text{ mA for } t > 0$$

Verification Problems

VP 8-1

First look at the circuit. The initial capacitor voltage is $v_c(0) = 8$ V. The steady-state capacitor voltage is $v_c = 4$ V.

We expect an exponential transition from 8 volts to 4 volts. That's consistent with the plot.

Next, let's check the shape of the exponential transition. The Thevenin resistance of the part of the circuit connected to the capacitor is $R_t = \frac{(2000)(4000)}{2000 + 4000} = \frac{4}{3}$ k Ω so the time constant is

$$\tau = R_t C = \left(\frac{4}{3} \times 10^3\right) (0.5 \times 10^{-6}) = \frac{2}{3} \text{ ms. Thus the capacitor voltage is}$$

$$v_c(t) = 4 e^{-t/0.67} + 4 \text{ V}$$

where t has units of ms. To check the point labeled on the plot, let $t_1 = 1.33$ ms. Then

$$v_c(t_1) = 4 e^{-\left(\frac{1.33}{.67}\right)} + 4 = 4.541 \simeq 4.5398 \text{ V}$$

So the plot is correct.

VP 8-2

The initial and steady-state inductor currents shown on the plot agree with the values obtained from the circuit.

Next, let's check the shape of the exponential transition. The Thevenin resistance of the part of the circuit connected to the inductor is $R_t = \frac{(2000)(4000)}{2000 + 4000} = \frac{4}{3}$ k Ω so the time constant is

$$\tau = \frac{L}{R_t} = \frac{5}{\frac{4}{3} \times 10^3} = \frac{15}{4} \text{ ms. Thus inductor current is}$$

$$i_L(t) = 2 e^{-t/3.75} + 5 \text{ mA}$$

where t has units of ms. To check the point labeled on the plot, let $t_1 = 3.75$ ms. Then

$$i_L(t_1) = 2 e^{-\left(\frac{3.75}{3.75}\right)} + 5 = 4.264 \text{ mA} \neq 4.7294 \text{ mA}$$

so the plot does not correspond to this circuit.

VP 8-3

Notice that the steady-state inductor current does not depend on the inductance, L . The initial and steady-state inductor currents shown on the plot agree with the values obtained from the circuit.

After $t = 0$

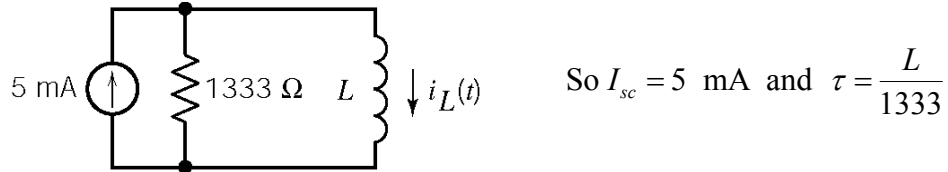

The inductor current is given by $i_L(t) = -2e^{-1333t/L} + 5 \text{ mA}$, where t has units of seconds and L has units of Henries. Let $t_1 = 3.75 \text{ ms}$, then

$$4.836 = i_L(t_1) = -2e^{-(1333)(0.00375)/L} + 5 = -2e^{-5/L} + 5$$

so

$$\frac{4.836 - 5}{-2} = e^{-5/L}$$

and

$$L = \frac{-5}{\ln\left(\frac{4.836 - 5}{-2}\right)} = 2 \text{ H}$$

is the required inductance.

VP 8-4

First consider the circuit. When $t < 0$ and the circuit is at steady-state:

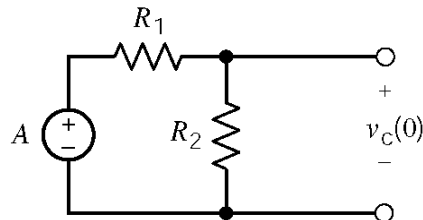

For $t > 0$

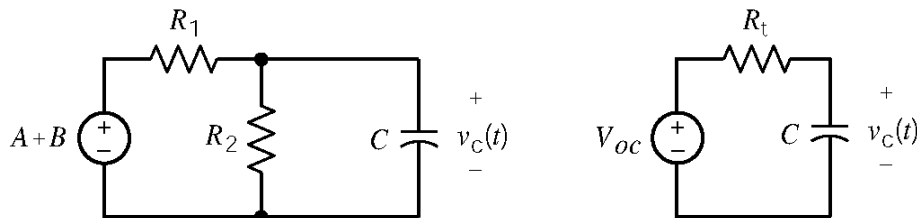

So

$$V_{oc} = \frac{R_2}{R_1 + R_2}(A + B), \quad R_t = \frac{R_1 R_2}{R_1 + R_2} \quad \text{and} \quad \tau = \frac{R_1 R_2 C}{R_1 + R_2}$$

Next, consider the plot. The initial capacitor voltage is ($v_c(0) = -2$) and the steady-state capacitor voltage is ($V_{oc} = 4$ V), so

$$v_c(t) = -6e^{-t/\tau} + 4$$

At $t_1 = 1.333$ ms

$$3.1874 = v_c(t_1) = -6e^{-0.001333/\tau} + 4$$

so

$$\tau = \frac{-0.001333}{\ln\left(\frac{-4+3.1874}{-6}\right)} = 0.67 \text{ ms}$$

Combining the information obtained from the circuit with the information obtained from the plot gives

$$\frac{R_2}{R_1+R_2}A = -2, \quad \frac{R_2}{R_1+R_2}(A+B) = 4, \quad \frac{R_1R_2C}{R_1+R_2} = 0.67 \text{ ms}$$

There are many ways that A, B, R_1 , R_2 , and C can be chosen to satisfy these equations. Here is one convenient way. Pick $R_1 = 3000$ and $R_2 = 6000$. Then

$$\frac{2A}{3} = -2 \Rightarrow A = -3$$

$$\frac{2(A+B)}{3} = 4 \Rightarrow B-3 = 6 \Rightarrow B = 9$$

$$2000 \cdot C = \frac{2}{3} \text{ ms} \Rightarrow \frac{1}{3} \mu\text{F} = C$$

Design Problems

DP 8-1

Steady-state response when the switch is open: $6 = \frac{R_3}{R_1+R_2+R_3} 12 \Rightarrow R_1 + R_2 = R_3$.

Steady-state response when the switch is closed: $10 = \frac{R_3}{R_1+R_3} 12 \Rightarrow R_1 = \frac{R_3}{5}$.

$$10 \text{ ms} = 5 \tau = (R_1 \parallel R_3)C = \frac{R_3}{6}C$$

Let $C = 1 \mu\text{F}$. Then $R_3 = 60 \text{ k}\Omega$, $R_1 = 30 \text{ k}\Omega$ and $R_2 = 30 \text{ k}\Omega$.

DP 8-2

steady state response when the switch is open : $0.001 = \frac{12}{R_1 + R_2} \Rightarrow R_1 + R_2 = 12 \text{ k}\Omega$.

steady state response when the switch is open: $0.004 = \frac{12}{R_1} \Rightarrow R_1 = 3 \text{ k}\Omega$.

Therefore, $R_2 = 9 \text{ k}\Omega$.

$$10 \text{ ms} = 5 \tau = 5 \left(\frac{L}{R_1 + R_2} \right) = \frac{L}{2400} \Rightarrow L = 240 \text{ H}$$

DP 8-3

$R_t = 50 \text{ k}\Omega$ when the switch is open and $R_t = 49 \text{ k}\Omega \approx 50 \text{ k}\Omega$ when the switch is closed so use $R_t = 50 \text{ k}\Omega$.

$$(a) \Delta t = 5 R_t C \Rightarrow C = \frac{10^{-6}}{5(50 \times 10^3)} = 4 \text{ pF}$$

$$(b) \Delta t = 5(50 \times 10^3)(2 \times 10^{-6}) = 0.5 \text{ s}$$

DP 8-4

$R_t = 50 \text{ k}\Omega$ when the switch is open and $R_t = 49 \text{ k}\Omega \approx 50 \text{ k}\Omega$ when the switch is closed so use $R_t = 50 \text{ k}\Omega$.

$$\text{When the switch is open: } 5e^{-\Delta t / \tau} = (1-k)5 \Rightarrow \ln(1-k) = -\frac{\Delta t}{\tau} \Rightarrow \Delta t = -\tau \ln(1-k)$$

$$\text{When the switch is open: } 5 - 5e^{-\Delta t / \tau} = k5 \Rightarrow \Delta t = -\tau \ln(1-k)$$

$$(a) C = \frac{10^{-6}}{-\ln(1-.95)(50 \times 10^3)} = 6.67 \text{ pF}$$

$$(b) \Delta t = -\ln(1-.95)(50 \times 10^3)(2 \times 10^{-6}) = 0.3 \text{ s}$$

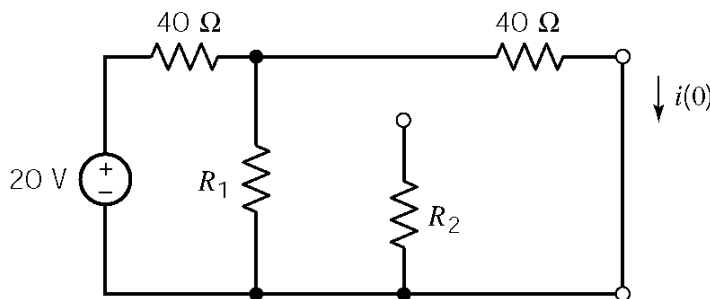
DP 8-5

$$i(0) = \frac{20}{40 + \frac{40R_1}{40 + R_1}} \times \frac{R_1}{R_1 + 40}$$

For
 $t > 0$:

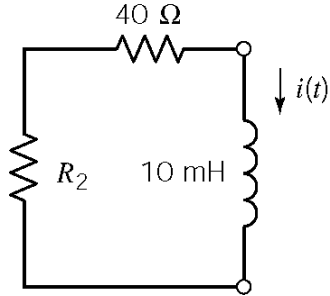

$$i(t) = i(0) e^{-t/\tau} \quad \text{where } \tau = \frac{L}{R_t} = \frac{10^{-2}}{40+R_2}$$

At $t < 200 \mu\text{s}$ we need $i(t) > 60 \text{ mA}$ and $i(t) < 180 \text{ mA}$

First let's find a value of R_2 to cause $i(0) < 180 \text{ mA}$.

Try $R_2 = 40 \Omega$. Then $i(0) = \frac{1}{6} \text{ A} = 166.7 \text{ mA}$ so $i(t) = 0.1667 e^{-t/\tau}$.

Next, we find a value of R_2 to cause $i(0.0002) > 60 \text{ mA}$.

Try $R_2 = 10 \Omega$, then $\tau = \frac{10^{-2}}{50} = 0.2 \text{ ms} = \frac{1}{5000} \text{ s}$.

$$i(0.0002) = 166.7 \times 10^{-3} e^{-5000 \times 0.0002} = 166.7 \times 10^{-3} e^{-1} = 61.3 \text{ mA}$$

DP 8-6

The current waveform will look like this:

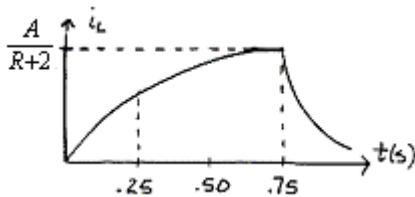

We only need to consider the rise time:

$$i_L(t) = \frac{V_s}{R+2} (1 - e^{-t/\tau}) = \frac{A}{R+2} (1 - e^{-t/\tau})$$

where

$$\tau = \frac{L}{R_t} = \frac{0.2}{3} = \frac{1}{15} \text{ s}$$

$$\therefore i_L(t) = \frac{A}{3} (1 - e^{-15t})$$

Now find A so that $i_L^2 R_{fuse} \geq 10 \text{ W}$ during $0.25 \leq t \leq 0.75 \text{ s}$

$$\therefore \text{we want } [i_L^2(0.25)] R_{fuse} = 10 \text{ W} \Rightarrow \frac{A^2}{9} (1 - e^{-15(0.25)})^2 (1) = 10 \Rightarrow \underline{A = 9.715 \text{ V}}$$

Chapter 9 - Complete Response of Circuits with Two Energy Storage Elements

Exercises

Ex. 9.3-1

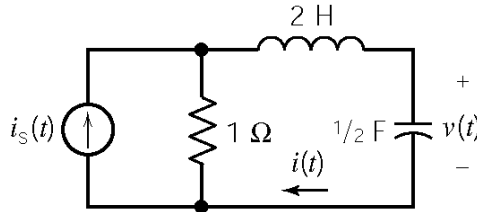

Apply KVL to right mesh:

$$2 \frac{di(t)}{dt} + v(t) + 1(i(t) - i_s(t)) = 0$$

$$\Rightarrow v(t) = -2 \frac{di(t)}{dt} - (i(t) - i_s(t))$$

The capacitor current and voltage are related by

$$i(t) = \frac{1}{2} \frac{dv(t)}{dt} = \frac{1}{2} \frac{d}{dt} \left(-2 \frac{di(t)}{dt} - i(t) + i_s(t) \right) = \frac{1}{2} \frac{di_s(t)}{dt} - \frac{1}{2} \frac{di(t)}{dt} - \frac{d^2 i(t)}{dt^2}$$

$$\therefore \frac{d^2 i(t)}{dt^2} + \frac{1}{2} \frac{di(t)}{dt} + i(t) = \frac{1}{2} \frac{di_s(t)}{dt}$$

Ex. 9.3-2

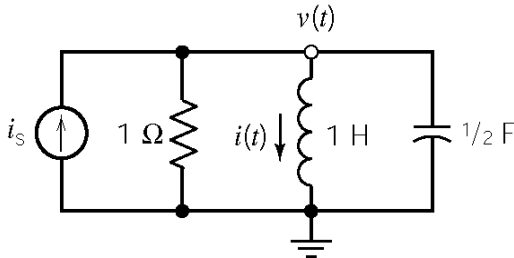

The inductor voltage is related to the inductor current by

$$v(t) = 1 \frac{di(t)}{dt}$$

Apply KCL at the top node:

$$i_s(t) = \frac{v(t)}{1} + i(t) + \frac{1}{2} \frac{dv(t)}{dt}$$

Using the operator $s = \frac{d}{dt}$ we have

$$\left. \begin{aligned} v(t) &= s i(t) \\ i_s(t) &= v(t) + i(t) + \frac{1}{2} s v(t) \end{aligned} \right\} \Rightarrow i_s(t) = v(t) + \frac{v(t)}{s} + \frac{1}{2} s v(t)$$

Therefore

$$2s i_s(t) = 2s v(t) + 2 v(t) + s^2 v(t) \Rightarrow \frac{d^2 v(t)}{dt^2} + 2 \frac{dv(t)}{dt} + 2 v(t) = 2 \frac{di_s(t)}{dt}$$

Ex. 9.3-3

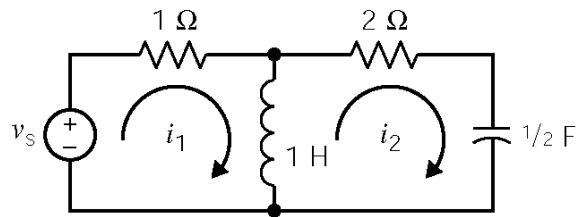

Using the operator $s = \frac{d}{dt}$, apply KVL to the left mesh:

$$i_1(t) + s(i_1(t) - i_2(t)) = v_s(t)$$

Apply KVL to the right mesh:

$$2i_2(t) + 2\frac{1}{s}i_2(t) + s(i_2(t) - i_1(t)) = 0$$

$$i_1(t) = 2\frac{1}{s}i_2(t) + \frac{2}{s^2}i_2(t) + i_2(t)$$

Combining these equations gives:

$$3s^2i_2(t) + 4si_2(t) + 2i_2(t) = s^2v_s(t) \quad \text{or} \quad \underline{3\frac{d^2i_2(t)}{dt^2} + 4\frac{di_2(t)}{dt} + 2i_2(t) = \frac{d^2v_s(t)}{dt^2}}$$

Ex. 9.4-1

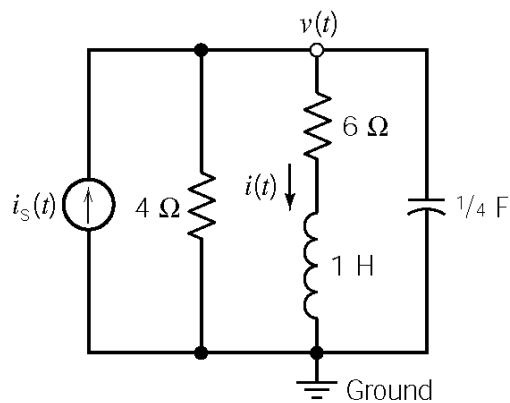

Using the operator $s = \frac{d}{dt}$, apply KCL at the top node:

$$i_s(t) = \frac{v(t)}{4} + i(t) + \frac{1}{4}s v(t)$$

Apply KVL to the right-most mesh:

$$v(t) - (s i(t) + 6 i(t)) = 0$$

Combining these equations gives:

$$s^2 i(t) + 7s i(t) + 10 i(t) = 4 i_s(t)$$

The characteristic equation is: $s^2 + 7s + 10 = 0$.

The natural frequencies are: $s = -2$ and $s = -5$.

Ex. 9.4-2

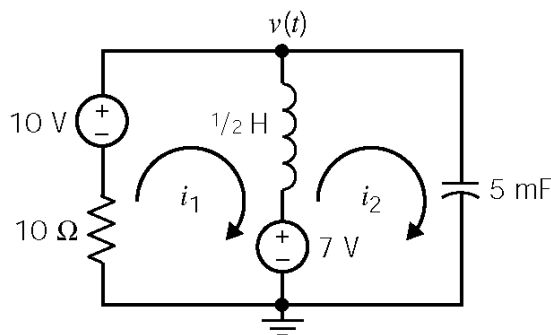

Assume zero initial conditions. Write mesh equations using the operator $s = \frac{d}{dt}$:

$$\frac{1}{2}s [i_1(t) - i_2(t)] + 7 + 10 i_1(t) - 10 = 0$$

and

$$v(t) - 7 - \frac{1}{2}s [i_1(t) - i_2(t)] = 0$$

Now $0.005s v(t) = i_2(t) \Rightarrow v(t) = 200 \frac{i_2(t)}{s}$ so the second mesh equation becomes:

$$200 \frac{i_2(t)}{s} - 7 - \frac{1}{2}s [i_1(t) - i_2(t)] = 0$$

Writing the mesh equation in matrix form:

$$\begin{bmatrix} 10 + \frac{s}{2} & -\frac{1}{2}s \\ -\frac{1}{2}s & \frac{1}{2}s + \frac{200}{s} \end{bmatrix} \begin{bmatrix} i_1(t) \\ i_2(t) \end{bmatrix} = \begin{bmatrix} 3 \\ 7 \end{bmatrix}$$

Obtain the characteristic equation by calculating a determinant:

$$\begin{vmatrix} 10 + \frac{s}{2} & -\frac{1}{2}s \\ -\frac{1}{2}s & \frac{1}{2}s + \frac{200}{s} \end{vmatrix} = s^2 + 20s + 400 = 0 \Rightarrow s_{1,2} = -10 \pm j17.3$$

Ex. 9.5-1

After $t = 0$, we have a parallel RLC circuit with

$$\alpha = \frac{1}{2RC} = \frac{1}{2(6)(1/42)} = \frac{7}{2} \text{ and } \omega_0^2 = \frac{1}{LC} = \frac{1}{(7)(1/42)} = 6$$

$$\therefore s_1, s_2 = -\alpha \pm \sqrt{\alpha^2 - \omega_0^2} = -\frac{7}{2} \pm \sqrt{\left(\frac{7}{2}\right)^2 - 6} = -1, -6$$

$$\therefore v_n(t) = A_1 e^{-t} + A_2 e^{-6t}. \text{ We need } v_n(0) \text{ and } \left. \frac{dv_n(t)}{dt} \right|_{t=0} \text{ to evaluate } A_1 \text{ \& } A_2.$$

At $t = 0^+$ we have:

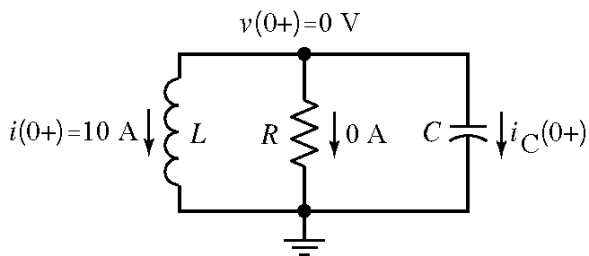

$$i_C(0^+) = -10 \text{ A} \Rightarrow \left. \frac{dv(t)}{dt} \right|_{t=0^+} = \frac{10}{\frac{1}{42}} = 420 \text{ V/s}$$

$$\text{Then } \left. \begin{aligned} v_n(0^+) = 0 &= A_1 + A_2 \\ \left. \frac{dv_n}{dt} \right|_{t=0^+} = -420 &= -A_1 - 6A_2 \end{aligned} \right\} A_1 = -84, A_2 = 84$$

Finally

$$\therefore \underline{v_n(t) = -84e^{-t} + 84e^{-6t} \text{ V}}$$

Ex. 9.5-2

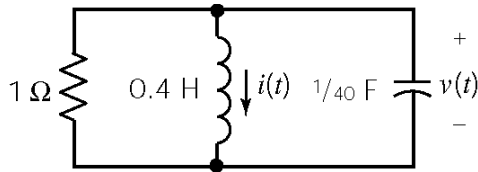

$$s^2 + \frac{1}{RC}s + \frac{1}{LC} = 0 \Rightarrow s^2 + 40s + 100 = 0$$

Therefore

$$s_1, s_2 = -2.68, -37.3$$

$$v_n(t) = A_1 e^{-2.68t} + A_2 e^{-37.3t}, \quad v(0) = 0 = A_1 + A_2$$

KCL at $t = 0^+$ yields $\frac{v(0^+)}{1} + i(0^+) + \frac{1}{40} \frac{dv(0^+)}{dt} = 0$ so

$$\frac{dv(0^+)}{dt} = -40 v(0^+) - 40 i(0^+) = -40(0) - 40(1) = -2.7A_1 - 37.3A_2$$

Therefore: $A_1 = -1.16, A_2 = 1.16 \Rightarrow \underline{v(t) = v_n(t) = -1.16e^{-2.68t} + 1.16e^{-37.3t}}$

Ex. 9.6-1

For parallel RLC circuits: $\alpha = \frac{1}{2RC} = \frac{1}{2(10)(10^{-3})} = 50, \quad \omega_o^2 = \frac{1}{LC} = \frac{1}{(0.4)(10^{-3})} = 2500$

The roots of the characteristic equations are: $\therefore s_{1,2} = -50 \pm \sqrt{(50)^2 - 2500} = -50, -50$

The natural response is $v_n(t) = A_1 e^{-50t} + A_2 t e^{-50t}$.

At $t = 0^+$ we have:

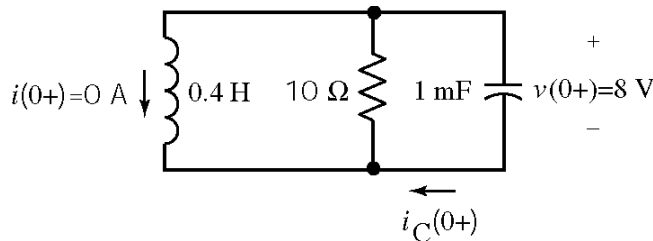

$$i_c(0^+) = \frac{-v(0^+)}{10\Omega} = -.8V$$

$$\therefore \left. \frac{dv(t)}{dt} \right|_{t=0^+} = \frac{i_c(0^+)}{c} = -800 \text{ V/s}$$

So $v_n(0^+) = 8 = A_1 \Rightarrow v_n(t) = 8e^{-50t} + A_2 t e^{-50t}$

$$\frac{dv(0^+)}{dt} = -800 = -400 + A_2 \Rightarrow A_2 = -400$$

$\therefore v_n(t) = 8e^{-50t} - 400t e^{-50t} \text{ V}$

Ex. 9.7-1

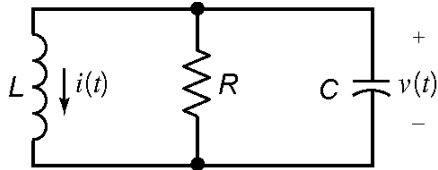

$$\alpha = \frac{1}{2RC} = \frac{1}{2(62.5)(10^{-6})} = 8000$$

$$\omega_o^2 = \frac{1}{LC} = \frac{1}{(.01)(10^{-6})} = 10^8$$

$$\therefore s = -\alpha \pm \sqrt{\alpha^2 - \omega_o^2} = -8000 \pm \sqrt{(8000)^2 - 10^8} = -8000 \pm j 6000$$

$$\therefore v_n(t) = e^{-8000t} [A_1 \cos 6000t + A_2 \sin 6000t]$$

at $t = 0^+$

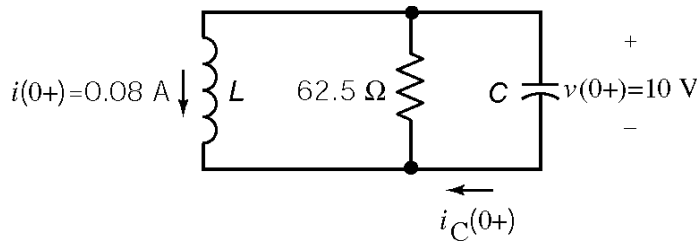

$$0.08 + \frac{10}{62.5} + i_c(0^+) = 0$$

$$\Rightarrow i_c(0^+) = -0.24 \text{ A}$$

$$\therefore \frac{dv(0^+)}{dt} = \frac{i_c(0^+)}{C} = -2.4 \times 10^5 \text{ V/s}$$

$$v_n(0^+) = 10 = A_1 \text{ and } \frac{dv_n(0^+)}{dt} = -2.4 \times 10^5 = 6000A_2 - 8000A_1 \Rightarrow A_2 = -26.7$$

$\therefore v_n(t) = e^{-8000t} [10 \cos 6000t - 26.7 \sin 6000t] \text{ V}$

Ex. 9.8-1

The differential equation is $\frac{d^2v(t)}{dt^2} + 5 \frac{dv(t)}{dt} + 6v(t) = v_s(t)$ so the characteristic equation is

$$s^2 + 5s + 6 = 0. \text{ The roots are } s_1, s_2 = -2, -3.$$

(a) $\frac{d^2v(t)}{dt^2} + 5 \frac{dv(t)}{dt} + 6v(t) = 8$. Try $v_f(t) = B$. Substituting into the differential equation gives

$$6B = 8 \therefore v_f(t) = 8/6 \text{ V.}$$

(b) $\frac{d^2v(t)}{dt^2} + 5\frac{dv(t)}{dt} + 6v(t) = 3e^{-4t}$. Try $v_f(t) = Be^{-4t}$. Substituting into the differential equation gives $(-4)^2B + 5(-4)B + 6B = 3 \Rightarrow B = \frac{3}{2}$. $\therefore v_f(t) = \frac{3}{2}e^{-4t}$.

(c) $\frac{d^2v(t)}{dt^2} + 5\frac{dv(t)}{dt} + 6v(t) = 2e^{-2t}$. Try $v_f(t) = Bte^{-2t}$ because -2 is a natural frequency. Substituting into the differential equation gives

$$(4t - 4)B + 5B(1 - 2t) + 6Bt = 2 \Rightarrow B = 2. \therefore v_f(t) = 2te^{-2t}.$$

Ex. 9.8-2

$\frac{d^2i(t)}{dt^2} + 9\frac{di(t)}{dt} + 20i(t) = 36 + 12t$. Try $i_f(t) = A + Bt$. Substituting into the differential equation gives $0 + 9B + 20(A + Bt) = 36 + 12t \Rightarrow B = 0.6$ and $A = 1.53$.

$$\therefore i_f(t) = 1.53 + 0.6t \text{ A}$$

Ex. 9.9-1

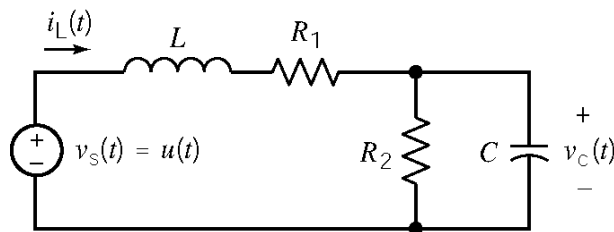

When the circuit reaches steady state after $t = 0$, the capacitor acts like an open circuit and the inductor acts like a short circuit. Under these conditions

$$v_C(\infty) = \frac{R_2}{R_1 + R_2} 1$$

Next, represent the circuit by a 2nd order differential equation:

KCL at the top node of R_2 gives: $\frac{v_C(t)}{R_2} + C\frac{d}{dt}v_C(t) = i_L(t)$

KVL around the outside loop gives: $v_s(t) = L\frac{d}{dt}i_L(t) + R_1i_L(t) + v_C(t)$

Use the substitution method to get

$$\begin{aligned}
 v_s(t) &= L \frac{d}{dt} \left(\frac{v_c(t)}{R_2} + C \frac{d}{dt} v_c(t) \right) + R_1 \left(\frac{v_c(t)}{R_2} + C \frac{d}{dt} v_c(t) \right) + v_c(t) \\
 &= LC \frac{d^2}{dt^2} v_c(t) + \left(\frac{L}{R_2} + R_1 C \right) \frac{d}{dt} v_c(t) + \left(1 + \frac{R_1}{R_2} \right) v_c(t)
 \end{aligned}$$

(a) $C = 1 \text{ F}$, $L = 0.25 \text{ H}$, $R_1 = R_2 = 1.309 \text{ } \Omega$

Use the steady state response as the forced response:

$$v_f = v_c(\infty) = \frac{R_2}{R_1 + R_2} 1 = \frac{1}{2} \text{ V}$$

The characteristic equation is

$$s^2 + \left(\frac{1}{R_2 C} + \frac{R_1}{L} \right) s + \left(\frac{1 + \frac{R_1}{R_2}}{LC} \right) = s^2 + 6s + 8 = (s + 2)(s + 4) = 0$$

so the natural response is

$$v_n = A_1 e^{-2t} + A_2 e^{-4t} \text{ V}$$

The complete response is

$$v_c(t) = \frac{1}{2} + A_1 e^{-2t} + A_2 e^{-4t} \text{ V}$$

$$i_L(t) = \frac{v_c(t)}{1.309} + \frac{d}{dt} v_c(t) = -1.236 A_1 e^{-2t} - 3.236 A_2 e^{-4t} + 0.3819$$

At $t = 0^+$

$$0 = v_c(0^+) = A_1 + A_2 + 0.5$$

$$0 = i_L(0^+) = -1.236 A_1 - 3.236 A_2 + 0.3819$$

Solving these equations gives $A_1 = -1$ and $A_2 = 0.5$, so

$$v_c(t) = \frac{1}{2} - e^{-2t} + \frac{1}{2} e^{-4t} \text{ V}$$

(b) $C = 1 \text{ F}$, $L = 1 \text{ H}$, $R_1 = 3 \text{ } \Omega$, $R_2 = 1 \text{ } \Omega$

Use the steady state response as the forced response:

$$v_f = v_c(\infty) = \frac{R_2}{R_1 + R_2} 1 = \frac{1}{4} \text{ V}$$

The characteristic equation is

$$s^2 + \left(\frac{1}{R_2 C} + \frac{R_1}{L} \right) s + \left(\frac{1 + \frac{R_1}{R_2}}{LC} \right) = s^2 + 4s + 4 = (s + 2)^2 = 0$$

so the natural response is

$$v_n = (A_1 + A_2 t) e^{-2t} \text{ V}$$

The complete response is

$$v_c(t) = \frac{1}{4} + (A_1 + A_2 t) e^{-2t} \text{ V}$$

$$i_L(t) = v_c(t) + \frac{d}{dt} v_c(t) = \frac{1}{4} + ((A_2 - A_1) - A_2 t) e^{-2t}$$

At $t = 0^+$

$$0 = v_c(0^+) = A_1 + \frac{1}{4}$$

$$0 = i_L(0^+) = \frac{1}{4} + A_2 - A_1$$

Solving these equations gives $A_1 = -0.25$ and $A_2 = -0.5$, so

$$v_c(t) = \frac{1}{4} - \left(\frac{1}{4} + \frac{1}{2} t \right) e^{-2t} \text{ V}$$

(c) $C = 0.125 \text{ F}$, $L = 0.5 \text{ H}$, $R_1 = 1 \Omega$, $R_2 = 4 \Omega$

Use the steady state response as the forced response:

$$v_f = v_c(\infty) = \frac{R_2}{R_1 + R_2} 1 = \frac{4}{5} \text{ V}$$

The characteristic equation is

$$s^2 + \left(\frac{1}{R_2 C} + \frac{R_1}{L} \right) s + \left(\frac{1 + \frac{R_1}{R_2}}{LC} \right) = s^2 + 4s + 20 = (s + 2 - j4)(s + 2 + j4) = 0$$

so the natural response is

$$v_n = e^{-2t} (A_1 \cos 4t + A_2 \sin 4t) \text{ V}$$

The complete response is

$$v_c(t) = 0.8 + e^{-2t} (A_1 \cos 4t + A_2 \sin 4t) \text{ V}$$

$$i_L(t) = \frac{v_c(t)}{4} + \frac{1}{8} \frac{d}{dt} v_c(t) = 0.2 + \frac{A_2}{2} e^{-2t} \cos 4t - \frac{A_1}{2} e^{-2t} \sin 4t$$

At $t = 0^+$

$$0 = v_c(0^+) = 0.8 + A_1$$

$$0 = i_L(0^+) = 0.2 + \frac{A_2}{2}$$

Solving these equations gives $A_1 = -0.8$ and $A_2 = -0.4$, so

$$v_c(t) = 0.8 - e^{-2t} (0.8 \cos 4t + 0.4 \sin 4t) \text{ V}$$

Ex 9.9-2

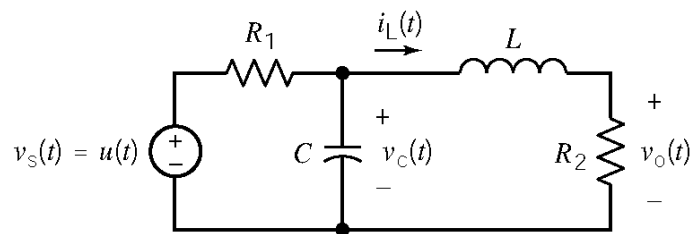

When the circuit reaches steady state after $t = 0$, the capacitor acts like an open circuit and the inductor acts like a short circuit. Under these conditions

$$v_c(\infty) = \frac{R_2}{R_1 + R_2} 1, \quad i_L(\infty) = \frac{1}{R_1 + R_2} \quad \text{and} \quad v_o(\infty) = \frac{R_2}{R_1 + R_2} 1$$

Next, represent the circuit by a 2nd order differential equation:

KVL around the right-hand mesh gives:
$$v_c(t) = L \frac{d}{dt} i_L(t) + R_2 i_L(t)$$

KCL at the top node of the capacitor gives:
$$\frac{v_s(t) - v_c(t)}{R_1} - C \frac{d}{dt} v_c(t) = i_L(t)$$

Use the substitution method to get

$$\begin{aligned} v_s(t) &= R_1 C \frac{d}{dt} \left(L \frac{d}{dt} i_L(t) + R_2 i_L(t) \right) + \left(L \frac{d}{dt} i_L(t) + R_2 i_L(t) \right) + R_1 i_L(t) \\ &= R_1 L C \frac{d^2}{dt^2} i_L(t) + (L + R_1 R_2 C) \frac{d}{dt} i_L(t) + (R_1 + R_2) i_L(t) \end{aligned}$$

Using $i_L(t) = \frac{v_o(t)}{R_2}$ gives

$$v_s(t) = \frac{R_1}{R_2} L C \frac{d^2}{dt^2} v_o(t) + \left(\frac{L}{R_2} + R_1 C \right) \frac{d}{dt} v_o(t) + \left(\frac{R_1 + R_2}{R_2} \right) v_o(t)$$

(a) $C = 1 \text{ F}$, $L = 0.25 \text{ H}$, $R_1 = R_2 = 1.309 \text{ } \Omega$

Use the steady state response as the forced response:

$$v_f = v_o(\infty) = \frac{R_2}{R_1 + R_2} 1 = \frac{1}{2} \text{ V}$$

The characteristic equation is

$$s^2 + \left(\frac{1}{R_1 C} + \frac{R_2}{L} \right) s + \left(\frac{1 + \frac{R_2}{R_1}}{LC} \right) = s^2 + 6s + 8 = (s + 2)(s + 4) = 0$$

so the natural response is

$$v_n = A_1 e^{-2t} + A_2 e^{-4t} \text{ V}$$

The complete response is

$$v_o(t) = \frac{1}{2} + A_1 e^{-2t} + A_2 e^{-4t} \text{ V}$$

$$i_L(t) = \frac{v_o(t)}{1.309} = \frac{1}{2.618} + \frac{A_1}{1.309} e^{-2t} + \frac{A_2}{1.309} e^{-4t} \text{ V}$$

$$v_c(t) = 1.309 i_L(t) + \frac{1}{4} \frac{d}{dt} i_L(t) = \frac{1}{2} + 0.6180 A_1 e^{-2t} + 0.2361 A_2 e^{-4t}$$

At $t = 0^+$

$$0 = i_L(0^+) = \frac{1}{2.618} + \frac{A_1}{1.309} + \frac{A_2}{1.309}$$

$$0 = v_c(0^+) = \frac{1}{2} + 0.6180 A_1 + 0.2361 A_2$$

Solving these equations gives $A_1 = -1$ and $A_2 = 0.5$, so

$$v_o(t) = \frac{1}{2} - e^{-2t} + \frac{1}{2} e^{-4t} \text{ V}$$

(b) $C = 1 \text{ F}$, $L = 1 \text{ H}$, $R_1 = 1 \text{ } \Omega$, $R_2 = 3 \text{ } \Omega$

Use the steady-state response as the forced response:

$$v_f = v_o(\infty) = \frac{R_2}{R_1 + R_2} 1 = \frac{3}{4} \text{ V}$$

The characteristic equation is

$$s^2 + \left(\frac{1}{R_1 C} + \frac{R_2}{L} \right) s + \left(\frac{1 + \frac{R_2}{R_1}}{LC} \right) = s^2 + 4s + 4 = (s + 2)^2 = 0$$

so the natural response is

$$v_n = (A_1 + A_2 t) e^{-2t} \text{ V}$$

The complete response is

$$v_o(t) = \frac{3}{4} + (A_1 + A_2 t) e^{-2t} \text{ V}$$

$$i_L(t) = \frac{v_o(t)}{3} = \frac{1}{4} + \left(\frac{A_1}{3} + \frac{A_2}{3} t \right) e^{-2t} \text{ V}$$

$$v_C(t) = 3i_L(t) + \frac{d}{dt} i_L(t) = \frac{3}{4} + \left(\left(\frac{A_1}{3} + \frac{A_2}{3} \right) + \frac{A_2}{3} t \right) e^{-2t}$$

At $t = 0^+$

$$0 = i_L(0^+) = \frac{A_1}{3} + \frac{1}{4}$$

$$0 = v_C(0^+) = \frac{3}{4} + \frac{A_1}{3} + \frac{A_2}{3}$$

Solving these equations gives $A_1 = -0.75$ and $A_2 = -1.5$, so

$$v_o(t) = \frac{3}{4} - \left(\frac{3}{4} + \frac{3}{2} t \right) e^{-2t} \text{ V}$$

(c) $C = 0.125 \text{ F}$, $L = 0.5 \text{ H}$, $R_1 = 4 \Omega$, $R_2 = 1 \Omega$

Use the steady state response as the forced response:

$$v_f = v_o(\infty) = \frac{R_2}{R_1 + R_2} 1 = \frac{1}{5} \text{ V}$$

The characteristic equation is

$$s^2 + \left(\frac{1}{R_1 C} + \frac{R_2}{L} \right) s + \left(\frac{1 + \frac{R_2}{R_1}}{LC} \right) = s^2 + 4s + 20 = (s + 2 - j4)(s + 2 + j4) = 0$$

so the natural response is

$$v_n = e^{-2t} (A_1 \cos 4t + A_2 \sin 4t) \text{ V}$$

The complete response is

$$v_o(t) = 0.2 + e^{-2t} (A_1 \cos 4t + A_2 \sin 4t) \text{ V}$$

$$i_L(t) = \frac{v_o(t)}{1} = 0.2 + e^{-2t} (A_1 \cos 4t + A_2 \sin 4t) \text{ V}$$

$$v_c(t) = i_L(t) + \frac{1}{2} \frac{d}{dt} i_L(t) = 0.2 + 2A_2 e^{-2t} \cos 4t - 2A_1 e^{-2t} \sin 4t$$

At $t = 0^+$

$$0 = i_L(0^+) = 0.2 + A_1$$

$$0 = v_c(0^+) = 0.2 + 2A_2$$

Solving these equations gives $A_1 = -0.8$ and $A_2 = -0.4$, so

$$v_c(t) = 0.2 - e^{-2t} (0.2 \cos 4t + 0.1 \sin 4t) \text{ V}$$

Ex. 9.10-1

At $t = 0^+$ no initial stored energy $\Rightarrow v_1(0^+) = v_2(0^+) = i(0^+) = 0$

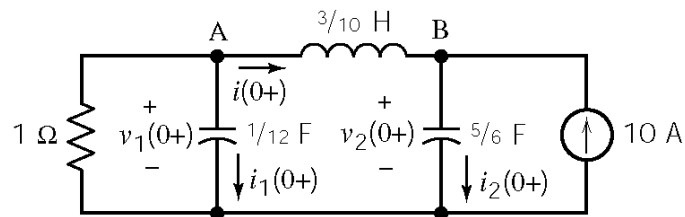

$$\text{KVL : } -0 + \frac{3}{10} \frac{di(0^+)}{dt} + 0 = 0 \Rightarrow \frac{di(0^+)}{dt} = 0$$

$$\text{KCL at A : } \frac{0}{1} + i_1(0^+) + 0 = 0 \Rightarrow \frac{dv_1(0^+)}{dt} = 0$$

$$\text{KCL at B : } -0 + i_2(0^+) - 10 = 0 \Rightarrow i_2(0^+) = \frac{5}{6} \frac{dv_2(0^+)}{dt} = 10 \Rightarrow \frac{dv_2(0^+)}{dt} = 12 \text{ V/s}$$

For $t > 0$:

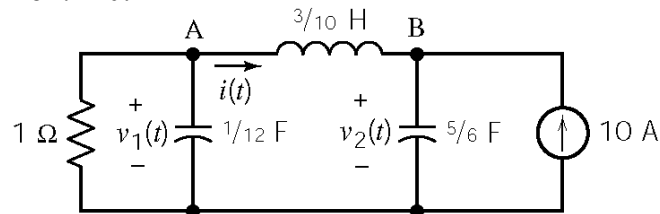

$$\text{KCL at A : } \frac{v_1}{1} + \frac{1}{12} \frac{dv_1}{dt} + i = 0$$

$$\text{KCL at B : } -i + \frac{5}{6} \frac{dv_2}{dt} = 10$$

$$\text{KVL: } -v_1 + \frac{3}{10} \frac{di}{dt} + v_2 = 0$$

Eliminating i yields

$$v_1 + \frac{1}{12} \frac{dv_1}{dt} + \frac{5}{6} \frac{dv_2}{dt} - 10 = 0$$

$$-v_1 + \frac{3}{10} \left(\frac{5}{6} \frac{d^2 v_2}{dt^2} \right) + v_2 = 0$$

Next

$$v_1 = v_2 + \frac{1}{4} \frac{d^2 v_2}{dt^2} \Rightarrow \frac{d v_1}{dt} = \frac{d^2 v_2}{dt^2} + \frac{1}{4} \frac{d^3 v_2}{dt^3}$$

Now, eliminating v_1

$$v_2 + \frac{1}{4} \frac{d^2 v_2}{dt^2} + \frac{1}{12} \left(\frac{d v_2}{dt} + \frac{1}{4} \frac{d^3 v_2}{dt^3} \right) + \frac{5}{6} \frac{d v_2}{dt} = 10$$

Finally, the circuit is represented by the differential equation:

$$\frac{d^3 v_2}{dt^3} + 12 \frac{d^2 v_2}{dt^2} + 44 \frac{d v_2}{dt} + 48 v_2 = 480$$

The characteristic equation is $s^3 + 12s^2 + 44s + 48 = 0$. Its roots are $s_{1,2,3} = -2, -4, -6$. The natural response is

$$v_n = A_1 e^{-2t} + A_2 e^{-4t} + A_3 e^{-6t}$$

Try $v_f = B$ as the forced response. Substitute into the differential equation and equate coefficients to get $B = 10$. Then

$$v_2(t) = v_n(t) + v_f(t) = A_1 e^{-2t} + A_2 e^{-4t} + A_3 e^{-6t} + 10$$

We have seen that $v_2(0^+) = 0$ and $\frac{d v_2(0^+)}{dt} = 12$ V/s. Also $\frac{d^2 v_2(0^+)}{dt^2} = 4[v_1(0^+) - v_2(0^+)] = 0$.

Then

$$v_2(0^+) = 0 = A_1 + A_2 + A_3 + 10$$

$$\frac{d v_2(0^+)}{dt} = 12 = -2A_1 - 4A_2 - 6A_3$$

$$\frac{d^2 v_2(0^+)}{dt^2} = 0 = 4A_1 + 16A_2 + 36A_3$$

Solving these equations yields $A_1 = -15$, $A_2 = 6$, $A_3 = -1$ so

$$v_2(t) = (-15 e^{-2t} + 6 e^{-4t} - e^{-6t} + 10) \text{ V}$$

Ex. 9.11-1

$s^2 + \frac{1}{RC}s + \frac{1}{LC} = 0$ In our case $L = 0.1$, $C = 0.1$ so we have $s^2 + \frac{10}{R}s + 100 = 0$

a)

$$R = 0.4 \Omega \Rightarrow s^2 + 25s + 100 = 0$$
$$s_{1,2} = -5, -20$$

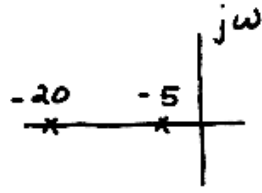

b)

$$R = 1 \Omega \Rightarrow s^2 + 10s + 100 = 0$$
$$s_{1,2} = -5 \pm j5\sqrt{3}$$

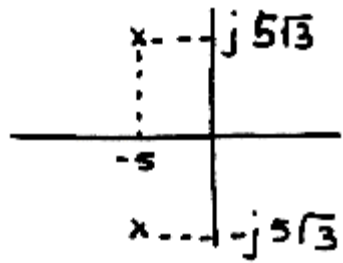

Problems

Section 9-3: Differential Equations for Circuits with Two Energy Storage Elements

P9.3-1

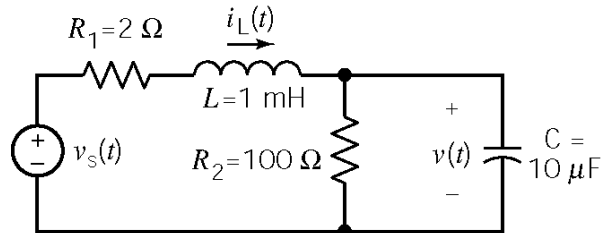

$$\text{KCL: } i_L(t) = \frac{v(t)}{R_2} + C \frac{dv(t)}{dt}$$

$$\text{KVL: } v_s(t) = R_1 i_L(t) + L \frac{di_L(t)}{dt} + v(t)$$

$$v_s(t) = R_1 \left[\frac{v(t)}{R_2} + C \frac{dv(t)}{dt} \right] + \frac{L}{R_2} \frac{dv(t)}{dt} + LC \frac{d^2v(t)}{dt^2} + v(t)$$

$$v_s(t) = \left[\frac{R_1}{R_2} + 1 \right] v(t) + \left[R_1 C + \frac{L}{R_2} \right] \frac{dv(t)}{dt} + [LC] \frac{d^2v(t)}{dt^2}$$

In this circuit $R_1 = 2 \Omega$, $R_2 = 100 \Omega$, $L = 1 \text{ mH}$, $C = 10 \mu\text{F}$ so

$$v_s(t) = 1.02v(t) + .00003 \frac{dv(t)}{dt} + 10^{-8} \frac{d^2v(t)}{dt^2}$$

$$\underline{10^8 v_s(t) = 1.02 \times 10^8 v(t) + 3000 \frac{dv(t)}{dt} + \frac{d^2v(t)}{dt^2}}$$

P9.3-2

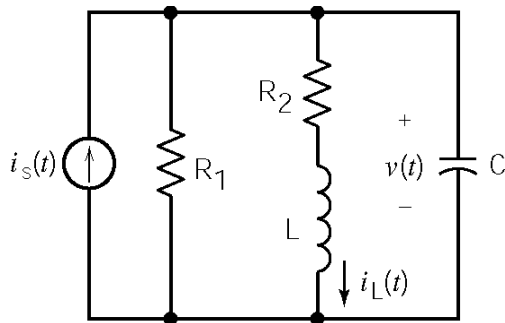

Using the operator $s = \frac{d}{dt}$ we have

$$\text{KCL: } i_s(t) = \frac{v(t)}{R_1} + i_L(t) + C s v(t)$$

$$\text{KVL: } v(t) = R_2 i_L(t) + L s i_L(t)$$

Solving by using Cramer's rule for $i_L(t)$:
$$i_L(t) = \frac{i_s(t)}{\frac{R_2}{R_1} + \frac{Ls}{R_1} + R_2 Cs + LCs^2 + 1}$$

$$\left[1 + \frac{R_2}{R_1} \right] i_L(t) + \left[\frac{L}{R_1} + R_2 C \right] s i_L(t) + [LC] s^2 i_L(t) = i_s(t)$$

In this circuit $R_1 = 100 \Omega$, $R_2 = 10 \Omega$, $L = 1 \text{ mH}$, $C = 10 \mu\text{F}$ so

$$1.1i_L(t) + .00011si_L(t) + 10^{-8}s^2i_L(t) = i_s(t)$$

$$1.1 \times 10^8 i_L(t) + 11000 \frac{di_L(t)}{dt} + \frac{d^2i_L(t)}{dt^2} = 10^8 i_s(t)$$

P9.3-3

After the switch closes, a source transformation gives:

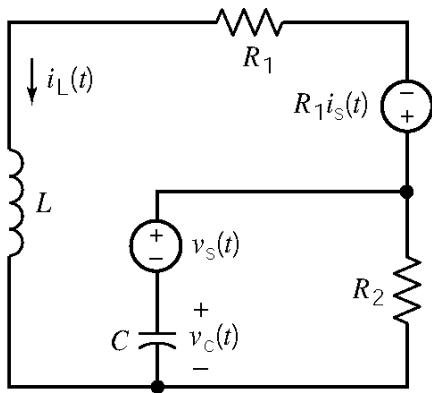

KCL:

$$i_L(t) + C \frac{dv_c(t)}{dt} + \frac{v_s(t) + v_c(t)}{R_2} = 0$$

KVL:

$$R_1 i_s(t) + R_1 i_L(t) + L \frac{di_L(t)}{dt} - v_c(t) - v_s(t) = 0$$

$$v_c(t) = R_1 i_s(t) + R_1 i_L(t) + L \frac{di_L(t)}{dt} - v_s(t)$$

Differentiating

$$\frac{dv_c(t)}{dt} = R_1 \frac{di_s(t)}{dt} + R_1 \frac{di_L(t)}{dt} + L \frac{d^2i_L(t)}{dt^2} - \frac{dv_s(t)}{dt}$$

Then

$$i_L(t) + C \left(R_1 \frac{di_s(t)}{dt} + R_1 \frac{di_L(t)}{dt} + L \frac{d^2i_L(t)}{dt^2} - \frac{dv_s(t)}{dt} \right) + \frac{v_s(t)}{R_2} + \frac{1}{R_2} \left(R_1 i_s(t) + R_1 i_L(t) + L \frac{di_L(t)}{dt} - v_s(t) \right) = 0$$

Solving for $i_L(t)$:

$$\frac{d^2i_L(t)}{dt^2} + \left[\frac{R_1}{L} + \frac{1}{R_2 C} \right] \frac{di_L(t)}{dt} + \left[\frac{R_1}{L R_2 C} + \frac{1}{L C} \right] i_L(t) = \frac{-R_1}{L C R_2} i_s(t) - \frac{R_1}{L} \frac{di_s(t)}{dt} + \frac{1}{L} \frac{dv_s(t)}{dt}$$

Section 9-4: Solution of the Second Order Differential Equation - The Natural Response

P9.4-1

From Problem P 9.3-2 the characteristic equation is:

$$1.1 \times 10^8 + 11000s + s^2 = 0 \Rightarrow s_1, s_2 = \frac{-11000 \pm \sqrt{(11000)^2 - 4(1.1 \times 10^8)}}{2} = \underline{\underline{-5500 \pm j8930}}$$

P9.4-2

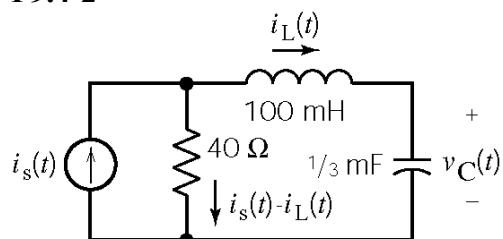

$$\text{KVL: } 40(i_s(t) - i_L(t)) = (100 \times 10^{-3}) \frac{di_L(t)}{dt} + v_C(t)$$

The current in the inductor is equal to the current in the capacitor so

$$i_L(t) = \left(\frac{1}{3} \times 10^{-3}\right) \frac{dv_C(t)}{dt}$$

$$v_C(t) = 40i_s(t) - \left(\frac{40}{3} \times 10^{-3}\right) \frac{dv_C(t)}{dt} - \left(\frac{100}{3} \times 10^{-6}\right) \frac{d^2v_C(t)}{dt^2}$$

$$\frac{d^2v_C(t)}{dt^2} + 400 \frac{dv_C(t)}{dt} + 30000v_C(t) = 40i_s(t)$$

$$s^2 + 400s + 30000 = 0 \Rightarrow (s+100)(s+300) = 0 \Rightarrow s_1 = -100, s_2 = -300$$

P9.4-3

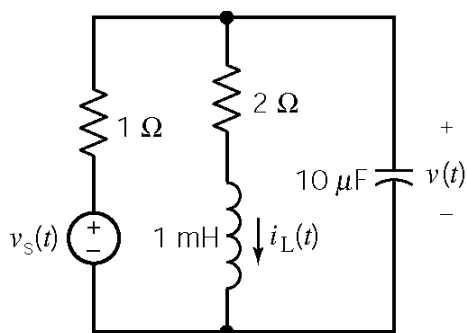

$$\text{KCL: } \frac{v(t) - v_s(t)}{1} + i_L(t) + (10 \times 10^{-6}) \frac{dv(t)}{dt} = 0$$

$$\text{KVL: } v(t) = 2i_L(t) + (1 \times 10^{-3}) \frac{di_L(t)}{dt}$$

$$0 = 2i_L(t) + (1 \times 10^{-3}) \frac{di_L(t)}{dt} - v_s(t) + i_L(t) + (10 \times 10^{-6})(2) \frac{di_L(t)}{dt} + (10 \times 10^{-6})(10^{-3}) \frac{d^2i_L(t)}{dt^2}$$

$$v_s(t) = 3i_L(t) + 0.00102 \frac{di_L(t)}{dt} + 10^{-8} \frac{d^2i_L(t)}{dt^2} \Rightarrow \frac{d^2i_L(t)}{dt^2} + 102000 \frac{di_L(t)}{dt} + 3 \times 10^8 i_L(t) = 10^8 v_s(t)$$

$$s^2 + 102000s + 3 \times 10^8 = 0 \Rightarrow s_1 = 3031, s_2 = -98969$$

Section 9.5: Natural Response of the Unforced Parallel RLC Circuit

P9.5-1

The initial conditions are $v(0) = 6$ V, $\frac{dv(0)}{dt} = -3000$ V/s. Using the operator $s = \frac{d}{dt}$, the node equation is $Csv(t) + \frac{v(t)}{R} + \frac{v(t) - v_s(t)}{sL} = 0$ or $\left(LCs^2 + \frac{L}{R}s + 1 \right)v(t) = v_s(t)$

The characteristic equation is: $s^2 + \frac{1}{RC}s + \frac{1}{LC} = 0 \Rightarrow s^2 + 500s + 40,000 = 0$

The natural frequencies are: $s_{1,2} = -250 \pm \sqrt{250^2 - 40,000} = -100, -400$

The natural response is of the form $v(t) = Ae^{-100t} + Be^{-400t}$. We will use the initial conditions to evaluate the constants A and B .

$$\left. \begin{aligned} v(0) &= 6 = A + B \\ \frac{dv(0)}{dt} &= -3000 = -100A - 400B \end{aligned} \right\} \Rightarrow A = -2 \text{ and } B = 8$$

Therefore, the natural response is

$$v(t) = -2e^{-100t} + 8e^{-400t} \quad t > 0$$

P9.5-2

The initial conditions are $v(0) = 2$ V, $i(0) = 0$.

The characteristic equation is: $s^2 + \frac{1}{RC}s + \frac{1}{LC} = 0 \Rightarrow s^2 + 4s + 3 = 0$

The natural frequencies are: $s_1, s_2 = -1, -3$

The natural response is of the form $v(t) = Ae^{-t} + Be^{-3t}$. We will use the initial conditions to evaluate the constants A and B .

Differentiating the natural response gives $\frac{dv(t)}{dt} = -Ae^{-t} - 3Be^{-3t}$. At $t = 0$ this becomes

$$\frac{dv(0)}{dt} = -A - 3B. \text{ Applying KCL gives } C \frac{dv(t)}{dt} + \frac{v(t)}{R} + i(t) = 0 \text{ or } \frac{dv(t)}{dt} = -\frac{v(t)}{RC} - \frac{i(t)}{C}.$$

At $t = 0$ this becomes $\frac{dv(0)}{dt} = -\frac{v(0)}{RC} - \frac{i(0)}{C}$. Consequently

$$-1A - 3B = -\frac{v(0)}{RC} - \frac{i(0)}{C} = -\frac{2}{1/4} - 0 = -8$$

Also, $v(0) = 2 = A + B$. Therefore $A = -1$ and $B = 3$. The natural response is

$$v(t) = -e^{-t} + 3e^{-3t} \text{ V}$$

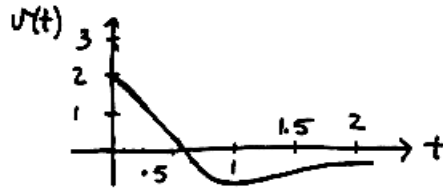

P9.5-3

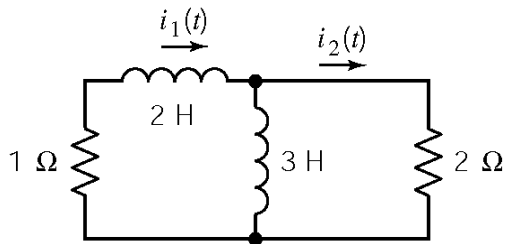

$$\text{KVL : } i_1 + 5 \frac{di_1(t)}{dt} - 3 \frac{di_2(t)}{dt} = 0 \quad (1)$$

$$\text{KVL : } -3 \frac{di_1(t)}{dt} + 3 \frac{di_2(t)}{dt} + 2i_2(t) = 0 \quad (2)$$

Using the operator $s = \frac{d}{dt}$, the KVL equations are

$$\left. \begin{aligned} (1+5s)i_1 + (-3s)i_2 &= 0 \\ (-3s)i_1 + (3s+2)i_2 &= 0 \end{aligned} \right\} \Rightarrow (1+5s)i_1 - (3s) \frac{3s}{3s+2} i_1 = 0 \Rightarrow \left[(1+5s)(3s+2) - (3s)^2 \right] i_1 = 0$$

The characteristic equation is $(1+5s)(3s+2) - 9s^2 = 6s^2 + 13s + 2 = 0 \Rightarrow s_{1,2} = -\frac{1}{6}, -2$

The currents are $i_1(t) = Ae^{-t/6} + Be^{-2t}$ and $i_2(t) = Ce^{-t/6} + De^{-2t}$, where the constants A, B, C and D must be evaluated using the initial conditions. Using the given initial values of the currents gives

$$i_1(0) = 11 = A + B \quad \text{and} \quad i_2(0) = 11 = C + D$$

Let $t = 0$ in the KVL equations (1) and (2) to get

$$\frac{di_1(0)}{dt} = -\frac{33}{2} = -\frac{A}{6} - 2B \quad \text{and} \quad \frac{di_2(0)}{dt} = -\frac{143}{6} = -\frac{C}{6} - D$$

So $A = 3, B = 8, C = -1$ and $D = 12$. Finally,

$$\underline{i_1(t) = 3e^{-t/6} + 8e^{-2t} \text{ A}} \quad \text{and} \quad \underline{i_2(t) = -e^{-t/6} + 12e^{-2t} \text{ A}}$$

Section 9.6: Natural Response of the Critically Damped Unforced Parallel RLC Circuit

P9.6-1

After $t = 0$

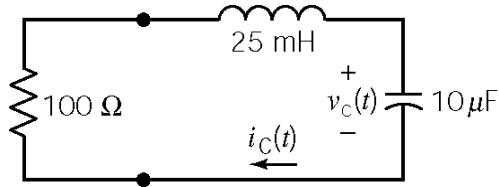

Using KVL: $100 i_c(t) + 0.025 \frac{di_c(t)}{dt} + v_c(t) = 0$

The capacitor current and voltage are related by:

$$i_c(t) = 10^{-5} \frac{dv_c(t)}{dt}$$

$$\therefore \frac{d^2 v_c(t)}{dt^2} + 4000 \frac{dv_c(t)}{dt} + 4 \times 10^6 v_c(t) = 0$$

The characteristic equation is: $s^2 + 4000s + 4 \times 10^6 = 0$

The natural frequencies are: $s_{1,2} = -2000, -2000$

The natural response is of the form: $v_c(t) = A_1 e^{-2000t} + A_2 t e^{-2000t}$

Before $t = 0$ the circuit is at steady state

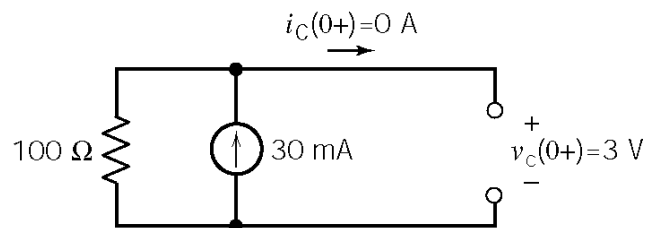

(The capacitor current is continuous at $t = 0$ in this circuit because it is equal to the inductor current.)

$$v_c(0^+) = 3 = A_1$$

$$\frac{dv_c(0^+)}{dt} = 0 = -2000A_1 + A_2 \Rightarrow A_2 = 6000$$

$$\therefore v_c(t) = (3 + 6000t)e^{-2000t} \text{ V for } t \geq 0$$

P9.6-2

After $t = 0$

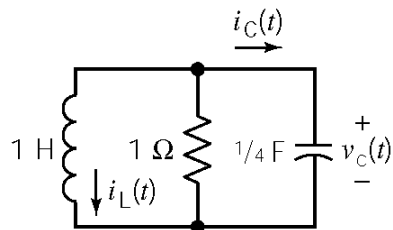

Using KCL:

$$\int_{-\infty}^t v_c(\tau) d\tau + v_c(t) + \frac{1}{4} \frac{dv_c(t)}{dt} = 0$$

$$\Rightarrow \frac{d^2 v_c(t)}{dt^2} + 4 \frac{dv_c(t)}{dt} + 4v_c(t) = 0$$

The characteristic equation is: $s^2 + 4s + 4 = 0$

The natural frequencies are: $s_{1,2} = -2, -2$

The natural response is of the form: $v_c(t) = A_1 e^{-2t} + A_2 t e^{-2t}$

Before $t = 0$ the circuit is at steady state

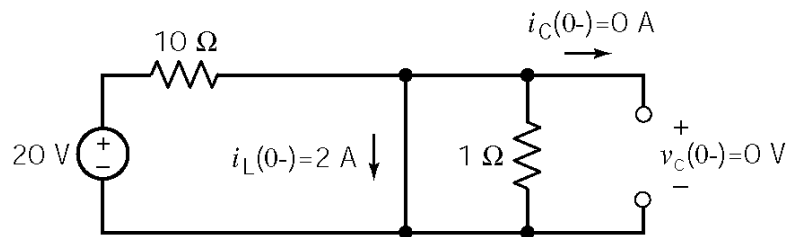

$$i_L(0^+) = i_L(0^-) \text{ and } v_C(0^+) = v_C(0^-)$$

$$i_C(0^+) = -i_L(0^+) = -2\text{ A}$$

$$\frac{dv(0^+)}{dt} = \frac{i_C(0^+)}{1/4} = -8\text{ V}$$

$$v_c(0^+) = 0 = A_1 \text{ and } \frac{dv_c(0^+)}{dt} = -8 = A_2 \Rightarrow \underline{v_c(t) = -8t e^{-2t}\text{ V}}$$

P9.6-3

Assume that the circuit is at steady state before $t = 0$. The initial conditions are

$$v_c(0^-) = 10^4\text{ V} \text{ \& } i_L(0^-) = 0\text{ A}$$

After $t = 0$

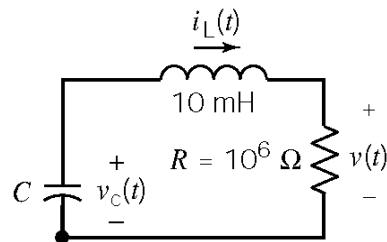

$$\text{KVL: } -v_c(t) + .01 \frac{di_L(t)}{dt} + 10^6 i_L(t) = 0 \quad (1)$$

$$\text{KCL: } i_L(t) = -C \frac{dv_C(t)}{dt} = -C \left[.01 \frac{d^2 i_L(t)}{dt^2} + 10^6 \frac{di_L(t)}{dt} \right] \quad (2)$$

$$\therefore .01 C \frac{d^2 i_L(t)}{dt^2} + 10^6 C \frac{di_L(t)}{dt} + i_L(t) = 0$$

The characteristic equation is: $(0.01 C)s^2 + (10^6 C)s + 1 = 0$

$$\text{The natural frequencies are: } s_{1,2} = \frac{-10^6 C \pm \sqrt{(10^6 C)^2 - 4(0.01 C)}}{2(0.01 C)}$$

For critically-damped response: $10^{12} C^2 - .04 C = 0 \Rightarrow C = 0.04\text{ pF}$ so $s_{1,2} = -5 \times 10^7, -5 \times 10^7$.

The natural response is of the form: $i_L(t) = A_1 e^{-5 \times 10^7 t} + A_2 t e^{-5 \times 10^7 t}$

$$\text{Now from (1)} \Rightarrow \frac{di_L}{dt}(0^+) = 100 [v_c(0^+) - 10^6 i_L(0^+)] = 10^6 \text{ A/s}$$

$$\text{So } i_L(0) = 0 = A_1 \text{ and } \frac{di_L(0)}{dt} = 10^6 = A_2 \quad \therefore i_L(t) = 10^6 t e^{-5 \times 10^7 t} \text{ A}$$

$$\text{Now } \underline{v(t) = 10^6 i_L(t) = 10^{12} t e^{-5 \times 10^7 t} \text{ V}}$$

P9.6-4

The characteristic equation can be shown to be: $s^2 + \frac{1}{RC}s + \frac{1}{LC} = s^2 + 500s + 62.5 \times 10^3 = 0$

The natural frequencies are: $s_{1,2} = -250, -250$

The natural response is of the form: $v(t) = A e^{-250t} + B t e^{-250t}$

$$v(0) = 6 = A \text{ and } \frac{dv(0)}{dt} = -3000 = -250A + B \Rightarrow B = -1500$$

$$\therefore \underline{v(t) = 6e^{-250t} - 1500t e^{-250t} \text{ V}}$$

P9.6-5

After $t=0$, using KVL yields:

$$\frac{di(t)}{dt} + Ri(t) + \underbrace{2 + 4 \int_0^t i(\tau) d\tau}_{v(t)} = 6 \quad (1)$$

Take the derivative with respect to t :

$$\frac{d^2 i(t)}{dt^2} + R \frac{di(t)}{dt} + 4i(t) = 0$$

The characteristic equation is $s^2 + Rs + 4 = 0$

Let $R=4$ for critical damping $\Rightarrow (s+2)^2 = 0$

So the natural response is $i(t) = A t e^{-2t} + B e^{-2t}$

$$i(0) = 0 \Rightarrow B = 0 \text{ and } \frac{di(0)}{dt} = 4 - R(i(0)) = 4 - R(0) = 4 = A$$

$$\therefore \underline{i(t) = 4t e^{-2t} \text{ A}}$$

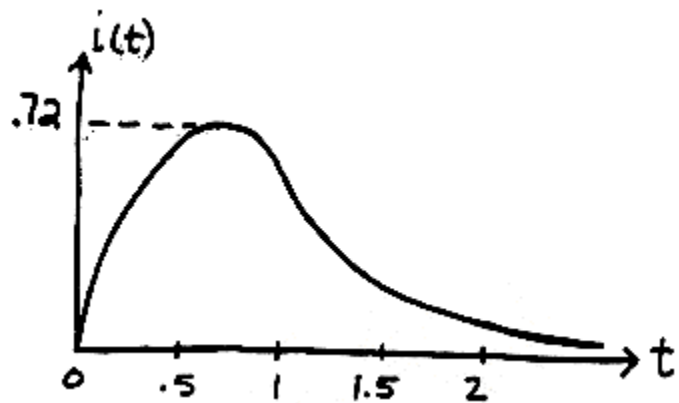

Section 9-7: Natural Response of an Underdamped Unforced Parallel RLC Circuit

P9.7-1

After $t = 0$

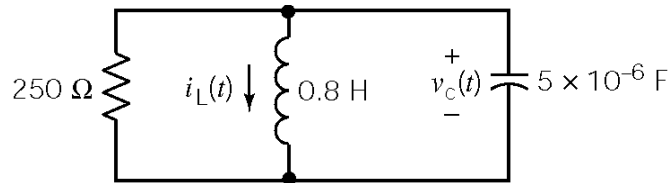

KCL:

$$\frac{v_c(t)}{250} + i_L(t) + 5 \times 10^{-6} \frac{dv_c(t)}{dt} = 0 \quad (1)$$

KVL:

$$v_c(t) = 0.8 \frac{di_L(t)}{dt} \quad (2)$$

$$\frac{d^2 v_c(t)}{dt^2} + 800 \frac{dv_c(t)}{dt} + 2.5 \times 10^5 v_c(t) = 0 \Rightarrow s^2 + 800s + 250,000 = 0, \quad s_{1,2} = -400 \pm j 300$$

The natural response is of the form $v_c(t) = e^{-400t} [A_1 \cos 300t + A_2 \sin 300t]$

Before $t = 0$ the circuit is at steady state:

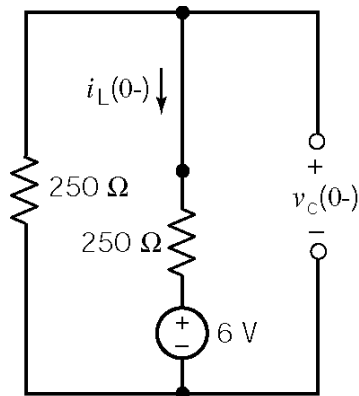

$$i_L(0^+) = i_L(0^-) = \frac{-6}{500} \text{ A}$$

$$v_c(0^+) = v_c(0^-) = 250 \left(\frac{-6}{500} \right) + 6 = 3 \text{ V}$$

From equation (1) :

$$\frac{dv_c(0^+)}{dt} = -2 \times 10^5 i_L(0^+) - 800 v_c(0^+) = 0$$

$$v_c(0^+) = 3 = A_1$$

$$\frac{dv_c(0^+)}{dt} = 0 = -400A_1 + 300A_2 \Rightarrow A_2 = 4$$

$$\therefore v_c(t) = e^{-400t} [3 \cos 300t + 4 \sin 300t] \text{ V}$$

P9.7-2

Before $t = 0$

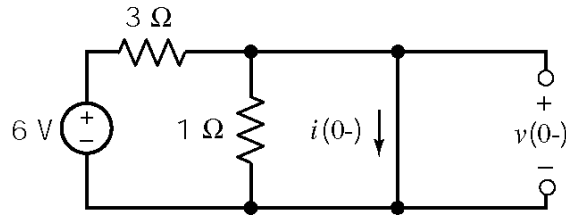

$$v(0^+) = v(0^-) = 0 \text{ V}$$

$$i(0^+) = i(0^-) = 2 \text{ A}$$

After $t = 0$

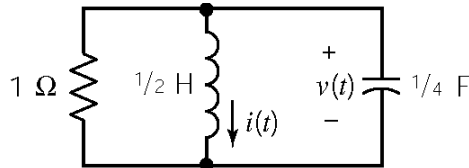

KCL :

$$\frac{v(t)}{1} + \frac{1}{4} \frac{dv(t)}{dt} + 2 \int_0^t v(\tau) d\tau + i(0) = 0$$

Using the operator $s = \frac{d}{dt}$ we have

$$v(t) + \left(\frac{1}{4}\right) s v(t) + \left(\frac{2}{s}\right) v(t) + i(0) = 0 \Rightarrow (s^2 + 4s + 8)v(t) = 0$$

The characteristic equation and natural frequencies are: $s^2 + 4s + 8 = 0 \Rightarrow s = -2 \pm j2$

The natural response is of the form: $v(t) = e^{-2t} [B_1 \cos 2t + B_2 \sin 2t]$

$$v(0) = 0 = B_1 \quad \text{and} \quad \frac{dv(0)}{dt} = 4[-i(0) - v(0)] = -4[2] = -8 = 2B_2 \quad \text{or} \quad B_2 = -4$$

so

$$v(t) = -4e^{-2t} \sin 2t \text{ V}$$

P9.7-3

After $t = 0$

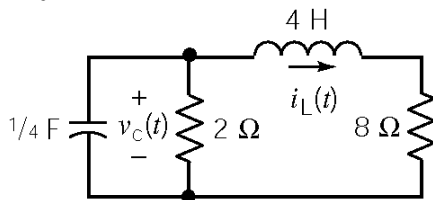

$$\text{KCL : } \frac{1}{4} \frac{dv_c(t)}{dt} + \frac{v_c(t)}{2} + i_L(t) = 0 \quad (1)$$

$$\text{KVL : } v_c(t) = \frac{4 di_L(t)}{dt} + 8 i_L(t) \quad (2)$$

$$\text{Characteristic Equation: } \frac{d^2 i_L(t)}{dt^2} + 4 \frac{di_L(t)}{dt} + 5 i_L(t) = 0 \Rightarrow s^2 + 4s + 5 = 0 \Rightarrow s_{1,2} = -2 \pm j$$

$$\text{Natural Response: } i_L(t) = e^{-2t} [A_1 \cos t + A_2 \sin t]$$

Before $t = 0$

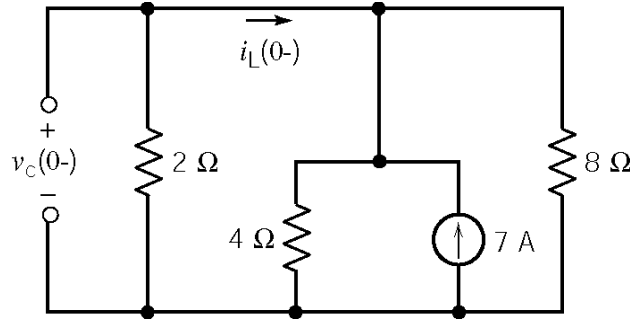

$$\frac{v_c(0^-)}{2} = 7 \left(\frac{4 \parallel 8}{4 \parallel 8 + 2} \right) \Rightarrow v_c(0^+) = v_c(0^-) = 8 \text{ V}$$

$$i_L(0^+) = i_L(0^-) = -\frac{8}{2} = -4 \text{ A}$$

$$\frac{di_L(0^+)}{dt} = \frac{v_c(0^+)}{4} - 2i_L(0^+) = \frac{8}{4} - 2(-4) = 10 \frac{\text{A}}{\text{s}}$$

$$i_L(0^+) = -4 = A_1$$

$$\frac{di_L(0^+)}{dt} = 10 = -2A_1 + A_2 \Rightarrow A_2 = 2$$

$$\therefore \underline{i_L(t) = e^{-2t} [-4 \cos t + 2 \sin t] \text{ A}}$$

P9.7-4

The plot shows an underdamped response, i.e. $v(t) = e^{-\alpha t} [k_1 \cos \omega t + k_2 \sin \omega t] + k_3$.

Examining the plot shows $v(\infty) = 0 \Rightarrow k_3 = 0$, $v(0) = 0 \Rightarrow k_1 = 0$.

Therefore, $v(t) = k_2 e^{-\alpha t} \sin \omega t$.

Again examining the plot we see that the maximum voltage is approximately 260 mV the time is approximately 5 ms and that the minimum voltage is approximately -200 mV the time is approximately 7.5 ms. The time between adjacent maximums is approximately 5 ms so

$\omega \approx \frac{2\pi}{5 \times 10^{-3}} = 1257 \text{ rad/s}$. Then

$$0.26 = k_2 e^{-\alpha(0.005)} \sin(1257 (.005)) \quad (1)$$

$$-0.2 = k_2 e^{-\alpha(0.0075)} \sin(1257 (.0075)) \quad (2)$$

To find α we divide (1) by (2) to get

$$-1.3 = e^{\alpha(0.0025)} \left(\frac{\sin(6.29 \text{ rad})}{\sin(9.43 \text{ rad})} \right) \Rightarrow e^{0.0025\alpha} = 1.95 \Rightarrow \alpha = 267$$

From (1) we get $k_2 = 544$. Then

$$v(t) = 544 e^{-267t} \sin 1257t \text{ V}$$

P9.7-5

After $t = 0$

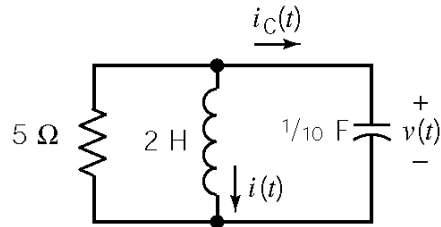

The characteristic equation is:

$$s^2 + \frac{1}{RC}s + \frac{1}{LC} = 0 \text{ or } s^2 + 2s + 5 = 0$$

The natural frequencies are: $s_{1,2} = -1 \pm j2$

The natural response is of the form:

$$v(t) = e^{-t} [B_1 \cos 2t + B_2 \sin 2t]$$

$v(0^+) = 2 = B_1$. From KCL, $i_c(0^+) = -\frac{v(0^+)}{5} - i(0^+) = -\frac{2}{5} - \frac{1}{10} = -\frac{1}{2} \frac{\text{V}}{\text{s}}$ so

$$\frac{dv(0^+)}{dt} = 10 \left(-\frac{1}{2} \right) = -B_1 + 2B_2 \Rightarrow B_2 = -\frac{3}{2}$$

Finally, $v(t) = 2e^{-t} \cos 2t - \frac{3}{2}e^{-t} \sin 2t \text{ V } t \geq 0$

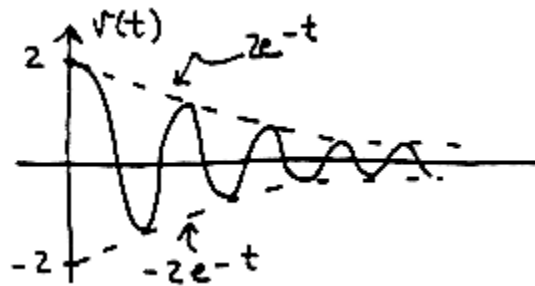

Section 9-8: Forced Response of an RLC Circuit

P9.8-1

After $t = 0$

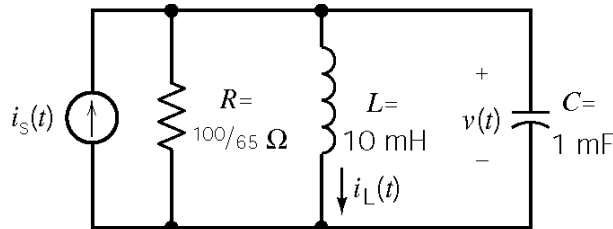

$$\text{KCL : } i_s(t) = \frac{v(t)}{R} + i_L(t) + C \frac{dv(t)}{dt}$$

$$\text{KVL : } v(t) = L \frac{di_L(t)}{dt}$$

$$i_s(t) = \frac{L}{R} \frac{di_L(t)}{dt} + i_L(t) + LC \frac{d^2i_L(t)}{dt^2}$$

$$\frac{d^2i_L(t)}{dt^2} + \frac{1}{RC} \frac{di_L(t)}{dt} + \frac{1}{LC} i_L(t) = \frac{1}{LC} i_s(t)$$

$$\frac{d^2i_L(t)}{dt^2} + (650) \frac{di_L(t)}{dt} + (10^5) i_L(t) = (10^5) i_s(t)$$

(a) Try a forced response of the form $i_f(t) = A$. Substituting into the differential equations gives

$$0 + 0 + A \frac{1}{(0.01)(1 \times 10^{-3})} = \frac{1}{(0.01)(1 \times 10^{-3})} \Rightarrow A = 1. \text{ Therefore } i_f(t) = 1 \text{ A.}$$

(b) Try a forced response of the form $i_f(t) = At + B$. Substituting into the differential equations

$$\text{gives } 0 + A \frac{65}{(100)(0.001)} + (At + B) \frac{1}{(0.01)(0.001)} = 0.5t. \text{ Therefore } A = 0.5 \text{ and}$$

$$B = -3.25 \times 10^{-3}. \text{ Finally } \underline{i_f(t) = 5t - 3.25 \times 10^{-3} \text{ A.}}$$

(c) Try a forced response of the form $i_f(t) = A e^{-250t}$. It doesn't work so try a forced response of the form $i_f(t) = B t e^{-250t}$. Substituting into the differential equation gives

$$\left[(-250)^2 B e^{-250t} - 500 B e^{-250t} \right] + 650 \left[(-250) B t e^{-250t} + B e^{-250t} \right] + 10^5 B t e^{-250t} = 2 e^{-250t}.$$

Equating coefficients gives

$$(250)^2 B + 650(-250)B + 10^5 B = 0 \Rightarrow \left[(250)^2 + 650(-250) + 10^5 \right] B = 0 \Rightarrow [0] B = 0$$

and

$$-500 B + 650 B = 2 \Rightarrow B = 0.0133$$

$$\text{Finally } \underline{i_f(t) = 0.0133 t e^{-250t} \text{ A.}}$$

P9.8-2

After $t = 0$

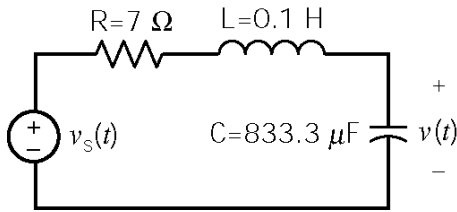

$$\frac{d^2v(t)}{dt} + \frac{R}{L} \frac{dv(t)}{dt} + \frac{1}{LC} v(t) = \frac{v_s(t)}{LC}$$

$$\frac{d^2v(t)}{dt} + 70 \frac{dv(t)}{dt} + 12000v(t) = 12000v_s(t)$$

(a) Try a forced response of the form $v_f(t) = A$. Substituting into the differential equations gives $0 + 0 + 12000A = 24000 \Rightarrow A = 2$. Therefore $v_f(t) = 2 \text{ V}$.

(b) Try a forced response of the form $v_f(t) = A + Bt$. Substituting into the differential equations gives $70A + 12000At + 12000B = 2400t$. Therefore $A = 0.2$ and $B = \frac{-70A}{12000} = -1.167 \times 10^{-3}$.

Finally $v_f(t) = (-1.167 \times 10^{-3})t + 0.2 \text{ V}$.

(c) Try a forced response of the form $v_f(t) = A e^{-30t}$. Substituting into the differential equations gives $900Ae^{-30t} - 2100Ae^{-30t} + 12000Ae^{-30t} = 12000e^{-30t}$. Therefore $A = \frac{12000}{10800} = 1.11$. Finally

$v_f(t) = 1.11e^{-250t} \text{ V}$.

Section 9-9: Complete Response of an RLC Circuit

P9.9-1

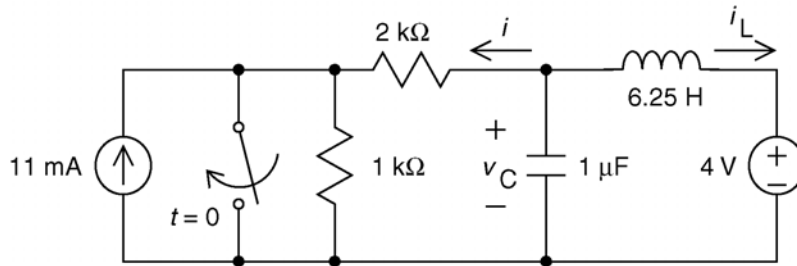

First, find the steady state response for $t < 0$, when the switch is open. Both inputs are constant so the capacitor will act like an open circuit at steady state, and the inductor will act like a short circuit. After a source transformation at the left of the circuit:

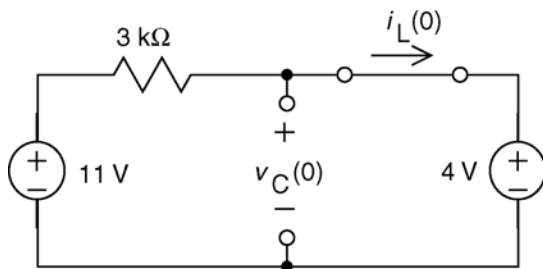

$$i_L(0) = \frac{11-4}{3000} = 2.33 \text{ mA}$$

and

$$v_C(0) = 4 \text{ V}$$

After the switch closes

Apply KCL at node a:

$$\frac{v_C}{R} + C \frac{d}{dt} v_C + i_L = 0$$

Apply KVL to the right mesh:

$$L \frac{d}{dt} i_L + V_s - v_C = 0 \Rightarrow v_C = L \frac{d}{dt} i_L + V_s$$

After some algebra:

$$\frac{d^2}{dt^2} i_L + \frac{1}{RC} \frac{d}{dt} i_L + \frac{1}{LC} i_L = -\frac{V_s}{RLC} \Rightarrow \frac{d^2}{dt^2} i_L + (500) \frac{d}{dt} i_L + (1.6 \times 10^5) i_L = -320$$

The characteristic equation is

$$s^2 + 500s + 1.6 \times 10^5 = 0 \Rightarrow s_{1,2} = -250 \pm j312 \text{ rad/s}$$

After the switch closes the steady-state inductor current is $i_L(\infty) = -2$ mA so

$$i_L(t) = -0.002 + e^{-250t} (A_1 \cos 312t + A_2 \sin 312t)$$

$$\begin{aligned} v_C(t) &= 6.25 \frac{d}{dt} i_L(t) + 4 \\ &= 6.25 e^{-250t} \left[-250(A_1 \cos 312t - A_2 \sin 312t) - 312(A_1 \sin 312t - A_2 \cos 312t) \right] + 4 \\ &= 6.25 e^{-250t} \left[(312A_2 - 250A_1) \cos 312t + (250A_2 + 312A_1) \sin 312t \right] + 4 \end{aligned}$$

Let $t = 0$ and use the initial conditions:

$$i_L(0^+) = 0.00233 = -0.002 + A_1 \Rightarrow 0.00433 = A_1$$

$$v_C(0^+) = 4 = 6.25(312A_2 - 250A_1) + 4 \Rightarrow A_2 = \frac{250}{312} A_1 = \frac{250}{312}(0.00433) = 0.00347$$

Then

$$\begin{aligned} i_L(t) &= -0.002 + e^{-250t} (0.00433 \cos 312t + 0.00345 \sin 312t) \\ &= -0.002 + 0.00555 e^{-250t} \cos(312t - 36.68^\circ) \text{ A} \end{aligned}$$

$$v_C(t) = 4 + 13.9 e^{-250t} \sin(312t) \text{ V}$$

$$i(t) = \frac{v_C(t)}{2000} = 2 + 6.95 e^{-250t} \sin(312t) \text{ mA}$$

(checked using LNAP on 7/22/03)

P9.9-2

First, find the steady state response for $t < 0$. The input is constant so the capacitor will act like an open circuit at steady state, and the inductor will act like a short circuit.

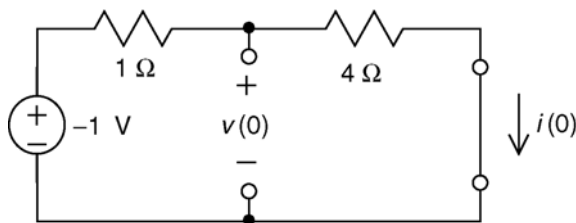

$$i(0) = \frac{-1}{1+4} = -0.2 \text{ A}$$

and

$$v(0) = \frac{4}{1+4}(-1) = -0.8 \text{ V}$$

For $t > 0$

Apply KCL at node a:

$$\frac{v - V_s}{R_1} + C \frac{d}{dt} v + i = 0$$

Apply KVL to the right mesh:

$$R_2 i + L \frac{d}{dt} i - v = 0 \Rightarrow v = R_2 i + L \frac{d}{dt} i$$

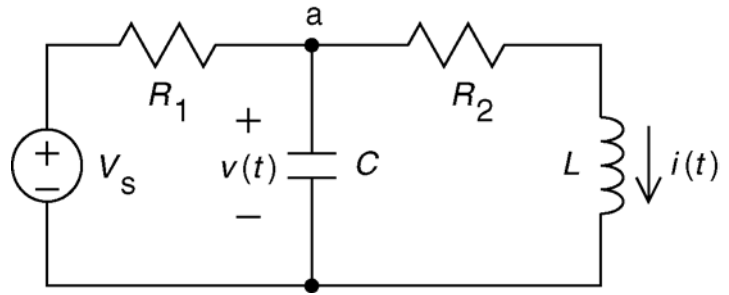

After some algebra:

$$\frac{d^2}{dt^2} i + \frac{L + R_1 R_2 C}{R_1 L C} \frac{d}{dt} i + \frac{R_1 + R_2}{R_1 L C} i = \frac{V_s}{R_1 L C} \Rightarrow \frac{d^2}{dt^2} i + 5 \frac{d}{dt} i + 5 i = 1$$

The forced response will be a constant, $i_f = B$ so $1 = \frac{d^2}{dt^2} B + 5 \frac{d}{dt} B + 5 B \Rightarrow B = 0.2 \text{ A}$.

To find the natural response, consider the characteristic equation:

$$0 = s^2 + 5s + 5 = (s + 3.62)(s + 1.38)$$

The natural response is

$$i_n = A_1 e^{-3.62t} + A_2 e^{-1.38t}$$

so

$$i(t) = A_1 e^{-3.62t} + A_2 e^{-1.38t} + 0.2$$

Then

$$v(t) = \left(4 i(t) + 4 \frac{d}{dt} i(t) \right) = -10.48 A_1 e^{-3.62t} - 1.52 A_2 e^{-1.38t} + 0.8$$

At $t=0+$

$$\begin{aligned} -0.2 &= i(0+) = A_1 + A_2 + 0.2 \\ -0.8 &= v(0+) = -10.48 A_1 - 1.52 A_2 + 0.8 \end{aligned}$$

so $A_1 = 0.246$ and $A_2 = -0.646$. Finally

$$i(t) = 0.2 + 0.246 e^{-3.62t} - 0.646 e^{-1.38t} \text{ A}$$

P9.9-3

First, find the steady state response for $t < 0$. The input is constant so the capacitors will act like an open circuits at steady state.

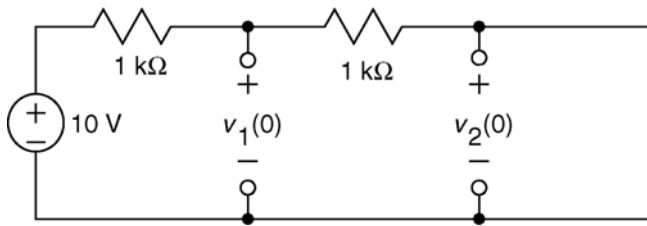

$$v_1(0) = \frac{1000}{1000+1000}(10) = 5 \text{ V}$$

and

$$v_2(0) = 0 \text{ V}$$

For $t > 0$,

Node equations:

$$\begin{aligned} \frac{v_1 - 10}{1000} + \left(\frac{1}{6} \times 10^{-6}\right) \frac{d}{dt} v_1 + \frac{v_1 - v_2}{1000} &= 0 \\ \Rightarrow 2v_1 + \left(\frac{1}{6} \times 10^{-3}\right) \frac{d}{dt} v_1 - 10 &= v_2 \end{aligned}$$

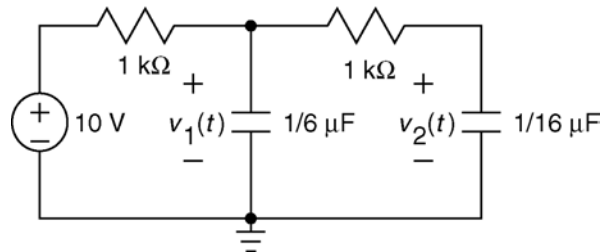

$$\begin{aligned} \frac{v_1 - v_2}{1000} &= \left(\frac{1}{16} \times 10^{-6}\right) \frac{d}{dt} v_2 \\ \Rightarrow v_1 - v_2 &= \left(\frac{1}{16} \times 10^{-3}\right) \frac{d}{dt} v_2 \end{aligned}$$

After some algebra:

$$\frac{d^2}{dt^2} v_1 + (2.8 \times 10^4) \frac{d}{dt} v_1 + (9.6 \times 10^7) v_1 = 9.6 \times 10^8$$

The forced response will be a constant, $v_f = B$ so

$$\frac{d^2}{dt^2} B + (2.8 \times 10^4) \frac{d}{dt} B + (9.6 \times 10^7) B = 9.6 \times 10^8 \Rightarrow B = 10 \text{ V}.$$

To find the natural response, consider the characteristic equation:

$$s^2 + (2.8 \times 10^4) s + (9.6 \times 10^7) = 0 \Rightarrow s_{1,2} = -4 \times 10^3, -2.4 \times 10^4$$

The natural response is

$$v_n = A_1 e^{-4 \times 10^3 t} + A_2 e^{-2.4 \times 10^4 t}$$

so

$$v_1(t) = A_1 e^{-4 \times 10^3 t} + A_2 e^{-2.4 \times 10^4 t} + 10$$

At $t = 0$

$$5 = v_1(0) = A_1 e^{-4 \times 10^3(0)} + A_2 e^{-2.4 \times 10^4(0)} + 10 = A_1 + A_2 + 10 \quad (1)$$

Next

$$2v_1 + \left(\frac{1}{6} \times 10^{-3}\right) \frac{d}{dt} v_1 - 10 = v_2 \Rightarrow \frac{d}{dt} v_1 = -12000v_1 + 6000v_2 + 6 \times 10^4$$

At $t = 0$

$$\frac{d}{dt} v_1(0) = -12000v_1(0) + 6000v_2(0) + 6 \times 10^4 = -12000(5) + 6000(0) + 6 \times 10^4 = 0$$

so

$$\frac{d}{dt} v_1(t) = A_1(-4 \times 10^3) e^{-4 \times 10^3 t} + A_2(-2.4 \times 10^4) e^{-2.4 \times 10^4 t}$$

At $t = 0^+$

$$0 = \frac{d}{dt} v_1(0) = A_1(-4 \times 10^3) e^{-4 \times 10^3(0)} + A_2(-2.4 \times 10^4) e^{-2.4 \times 10^4(0)} = A_1(-4 \times 10^3) + A_2(-2.4 \times 10^4)$$

so $A_1 = -6$ and $A_2 = 1$. Finally

$$v_1(t) = 10 + e^{-2.4 \times 10^4 t} - 6e^{-4 \times 10^3 t} \text{ V for } t > 0$$

P9.9-4

For $t > 0$

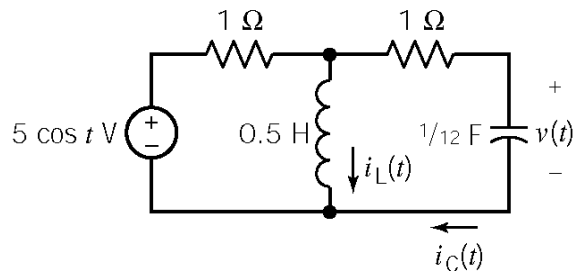

KCL at top node:

$$\left(0.5 \frac{di_L(t)}{dt} - 5 \cos t\right) + i_L(t) + \frac{1}{12} \frac{dv(t)}{dt} = 0 \quad (1)$$

KVL for right mesh:

$$0.5 \frac{di_L(t)}{dt} = \frac{1}{12} \frac{dv(t)}{dt} + v(t) \quad (2)$$

Taking the derivative of these equations gives:

$$\frac{d}{dt} \text{ of (1)} \Rightarrow 0.5 \frac{d^2 i_L(t)}{dt^2} + \frac{di_L(t)}{dt} + \frac{1}{12} \frac{d^2 v(t)}{dt^2} = -5 \sin t \quad (3)$$

$$\frac{d}{dt} \text{ of (2)} \Rightarrow 0.5 \frac{d^2 i_L(t)}{dt^2} = \frac{1}{12} \frac{d^2 v(t)}{dt^2} + \frac{dv(t)}{dt} \quad (4)$$

Solving for $\frac{d^2 i_L(t)}{dt^2}$ in (4) and $\frac{di_L(t)}{dt}$ in (2) & plugging into (3) gives

$$\frac{d^2 v(t)}{dt^2} + 7 \frac{dv(t)}{dt} + 12v(t) = -30 \sin t$$

The characteristic equation is: $s^2 + 7s + 12 = 0$.

The natural frequencies are $s_{1,2} = -3, -4$.

The natural response is of the form $v_n(t) = A_1 e^{-3t} + A_2 e^{-4t}$. Try a forced response of the form

$v_f(t) = B_1 \cos t + B_2 \sin t$. Substituting the forced response into the differential equation and

equating like terms gives $B_1 = \frac{21}{17}$ and $B_2 = -\frac{33}{17}$.

$$v(t) = v_n(t) + v_f(t) = A_1 e^{-3t} + A_2 e^{-4t} + \frac{21}{17} \cos t - \frac{33}{17} \sin t$$

We will use the initial conditions to evaluate A_1 and A_2 . We are given $i_L(0) = 0$ and $v(0) = 1$ V.

Apply KVL to the outside loop to get

$$1[i_C(t) + i_L(t)] + 1(i_C(t)) + v(t) - 5 \cos t = 0$$

At $t = 0^+$

$$i_C(0) = \frac{5 \cos(0) + i_L(0) - v(0)}{2} = \frac{5 + 0 - 1}{2} = 2 \text{ A}$$

$$\frac{dv(0)}{dt} = \frac{i_C(0)}{1/12} = \frac{2}{1/12} = 24 \text{ V/s}$$

$$\left. \begin{aligned} v(0^+) = 1 &= A_1 + A_2 + \frac{21}{17} \\ \frac{dv(0^+)}{dt} = 24 &= -3A_1 - 4A_2 - \frac{33}{17} \end{aligned} \right\} \Rightarrow \begin{aligned} A_1 &= 25 \\ A_2 &= -\frac{429}{17} \end{aligned}$$

Finally,

$$\therefore v(t) = \underline{\underline{25e^{-3t} - \frac{429e^{-4t} - 21 \cos t + 33 \sin t}{17} \text{ V}}}$$

P9.9-5

Use superposition. Find the response to inputs $2u(t)$ and $-2u(t-2)$ and then add the two responses. First, consider the input $2u(t)$:

For $0 < t < 2$ s

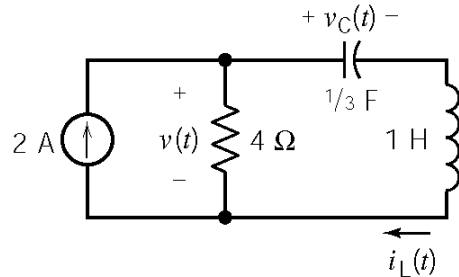

Using the operator $s = \frac{d}{dt}$ we have

$$\text{KVL: } v_c(t) + s i_L(t) + 4[i_L(t) - 2] = 0 \quad (1)$$

$$\text{KCL: } i_L(t) = \frac{1}{3} s v_c(t) \Rightarrow v_c(t) = \frac{3}{s} i_L(t) \quad (2)$$

Plugging (2) into (1) yields the characteristic equation: $(s^2 + 4s + 3) = 0$. The natural frequencies are $s_{1,2} = -1, -3$. The inductor current can be expressed as

$$i_L(t) = i_n(t) + i_f(t) = (A_1 e^{-t} + A_2 e^{-3t}) + 0 = A_1 e^{-t} + A_2 e^{-3t}.$$

Assume that the circuit is at steady state before $t = 0$. Then $v_c(0^+) = 0$ and $i_L(0^+) = 0$.

Using KVL we see that $(1) \frac{di_L(0^+)}{dt} = 4[2 - i_L(0^+)] - v_c(0^+) = 8$ A/s. Then

$$\left. \begin{aligned} i_L(0) = 0 &= A_1 + A_2 \\ \frac{di_L(0)}{dt} = 8 &= -A_1 - 3A_2 \end{aligned} \right\} A_1 = 4, A_2 = -4.$$

Therefore $i_L(t) = 4e^{-t} - 4e^{-3t}$ A. The response to $2u(t)$ is

$$\begin{aligned} v_1(t) = 8 - 4 i_L(t) &= \begin{cases} 0 & t < 0 \\ 8 - 16 e^{-t} + 16 e^{-3t} \text{ V} & t > 0. \end{cases} \\ &= [8 - 16 e^{-t} + 16 e^{-3t}] u(t) \text{ V} \end{aligned}$$

The response to $-2u(t-2)$ can be obtained from the response to $2u(t)$ by first replacing t by $t-2$ everywhere it appears and then multiplying by -1 . Therefore, the response to $-2u(t-2)$ is

$$v_2(t) = [-8 + 16e^{-(t-2)} - 16e^{-3(t-2)}] u(t-2) \text{ V}.$$

By superposition, $v(t) = v_1(t) + v_2(t)$. Therefore

$$v(t) = [8 - 16e^{-t} + 16e^{-3t}] u(t) + [-8 + 16e^{-(t-2)} - 16e^{-3(t-2)}] u(t-2) \text{ V}$$

P9.9-6

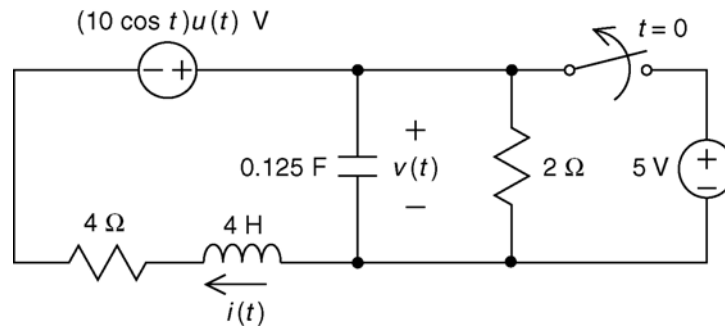

First, find the steady state response for $t < 0$, when the switch is closed. The input is constant so the capacitor will act like an open circuit at steady state, and the inductor will act like a short circuit.

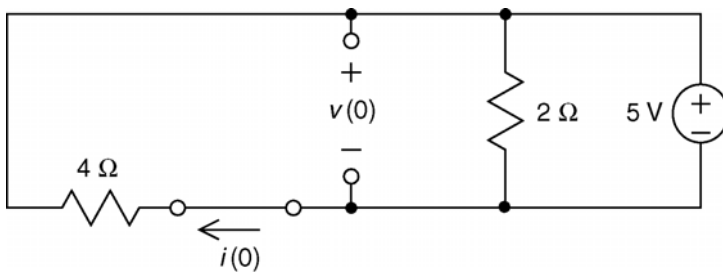

$$i(0) = -\frac{5}{4} = -1.25 \text{ A}$$

and

$$v(0) = 5 \text{ V}$$

After the switch opens

Apply KCL at node a:

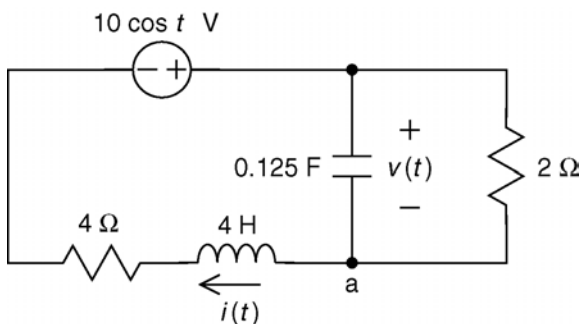

$$\frac{v}{2} + 0.125 \frac{d}{dt} v = i$$

Apply KVL to the right mesh:

$$-10 \cos t + v + 4 \frac{d}{dt} i + 4 i = 0$$

After some algebra:

$$\frac{d^2}{dt^2} v + 5 \frac{d}{dt} v + 6 v = 20 \cos t$$

The characteristic equation is

$$s^2 + 5s + 6 = 0 \Rightarrow s_{1,2} = -2, -3$$

Try

$$v_f = A \cos t + B \sin t$$

$$\frac{d^2}{dt^2} (A \cos t + B \sin t) + 5 \frac{d}{dt} (A \cos t + B \sin t) + 6 (A \cos t + B \sin t) = 20 \cos t$$

$$(-A \cos t - B \sin t) + 5(-A \sin t + B \cos t) + 6(A \cos t + B \sin t) = 20 \cos t$$

$$(-A + 5B + 6A) \cos t + (-B - 5A + 6B) \sin t = 20 \cos t$$

Equating the coefficients of the sine and cosine terms yields $A = 2$ and $B = 2$. Then

$$v_f = 2 \cos t + 2 \sin t$$

$$v(t) = 2 \cos t + 2 \sin t + A_1 e^{-2t} + A_2 e^{-3t}$$

Next

$$\frac{v(t)}{2} + 0.125 \frac{d}{dt} v(t) = i(t) \Rightarrow \frac{d}{dt} v(t) = 8i(t) - 4v(t)$$

$$\frac{d}{dt} v(0) = 8i(0) - 4v(0) = 8\left(-\frac{5}{4}\right) - 4(5) = -30 \frac{\text{V}}{\text{s}}$$

Let $t = 0$ and use the initial conditions:

$$5 = v(0) = 2 \cos 0 + 2 \sin 0 + A_1 e^{-0} + A_2 e^{-0} = 2 + A_1 + A_2$$

$$\frac{d}{dt} v(t) = -2 \sin t + 2 \cos t - 2 A_1 e^{-2t} - 3 A_2 e^{-3t}$$

$$-30 = \frac{d}{dt} v(0) = -2 \sin 0 + 2 \cos 0 - 2 A_1 e^{-0} - 3 A_2 e^{-0} = 2 - 2 A_1 - 3 A_2$$

So $A_1 = -23$ and $A_2 = 26$ and

$$v(t) = 2 \cos t + 2 \sin t - 23 e^{-2t} + 26 e^{-3t} \text{ V for } t > 0$$

P9.9-7

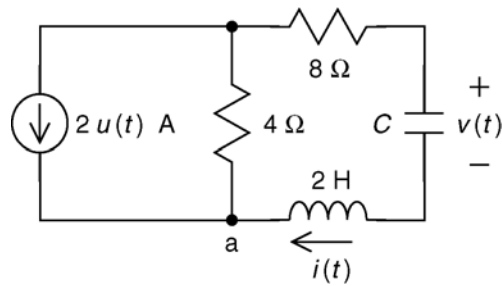

First, find the steady-state response for $t < 0$. The input is constant so the capacitor will act like an open circuit at steady state, and the inductor will act like a short circuit.

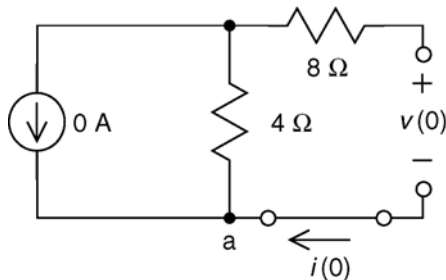

$$i(0) = 0 \text{ A}$$

and

$$v(0) = 0 \text{ V}$$

After $t = 0$

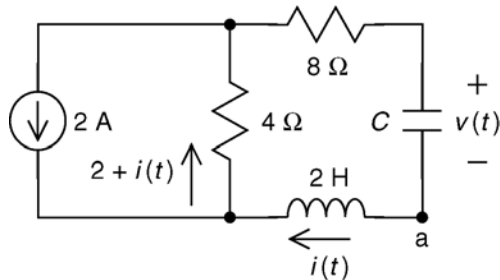

Apply KCL at node a: $C \frac{d}{dt} v = i$

Apply KVL to the right mesh:

$$8i + v + 2 \frac{d}{dt} i + 4(2 + i) = 0$$

$$12i + v + 2 \frac{d}{dt} i = -8$$

After some algebra: $\frac{d^2}{dt^2} v + (6) \frac{d}{dt} v + \left(\frac{1}{2C}\right) v = -\frac{4}{C}$

The forced response will be a constant, $v_f = B$ so

$$\frac{d^2}{dt^2} B + (6) \frac{d}{dt} B + \left(\frac{1}{2C}\right) B = -\frac{4}{C} \Rightarrow B = -8 \text{ V}$$

(a) When $C = 1/18 \text{ F}$ the differential equation is $\frac{d^2}{dt^2} v + (6) \frac{d}{dt} v + (9)v = -72$.

The characteristic equation is $s^2 + 6s + 9 = 0 \Rightarrow s_{1,2} = -3, -3$

Then $v(t) = (A_1 + A_2 t)e^{-3t} - 8$.

Using the initial conditions:

$$0 = v(0) = (A_1 + A_2(0))e^0 - 8 \Rightarrow A_1 = 8$$

$$0 = i(0) = C \frac{d}{dt} v(0) = C [-3(A_1 + A_2(0))e^0 + A_2 e^0] \Rightarrow A_2 = 3A_1 = 24$$

So

$$v(t) = (8 + 24t)e^{-3t} - 8 \text{ V for } t > 0$$

(b) When $C = 1/10$ F the differential equation is $\frac{d^2}{dt^2} v + (6) \frac{d}{dt} v + (5)v = -40$

The characteristic equation is $s^2 + 6s + 5 = 0 \Rightarrow s_{1,2} = -1, -5$

Then $v(t) = A_1 e^{-t} + A_2 e^{-5t} - 8$.

Using the initial conditions:

$$\left. \begin{aligned} 0 = v(0) = A_1 e^0 + A_2 e^0 - 8 &\Rightarrow A_1 + A_2 = 8 \\ 0 = \frac{d}{dt} v(0) = -A_1 e^0 - 5A_2 e^0 &\Rightarrow -A_1 - 5A_2 = 0 \end{aligned} \right\} \Rightarrow A_1 = 10 \text{ and } A_2 = -2$$

So

$$v(t) = 10e^{-t} - 2e^{-5t} - 8 \text{ V for } t > 0$$

(c) When $C = 1/20$ F the differential equation is $\frac{d^2}{dt^2} v + (6) \frac{d}{dt} v + (10)v = -80$

The characteristic equation is $s^2 + 6s + 10 = 0 \Rightarrow s_{1,2} = -3 \pm j$

Then $v(t) = e^{-3t} (A_1 \cos t + A_2 \sin t) - 8$.

Using the initial conditions:

$$0 = v(0) = e^0 (A_1 \cos 0 + A_2 \sin 0) - 8 \Rightarrow A_1 = 8$$

$$0 = \frac{d}{dt} v(0) = -3e^0 (A_1 \cos 0 + A_2 \sin 0) + e^0 (-A_1 \sin 0 + A_2 \cos 0) \Rightarrow A_2 = 3A_1 = 24$$

So

$$v(t) = e^{-3t} (8 \cos t + 24 \sin t) - 8 \text{ V for } t > 0$$

P9.9-8

The circuit will be at steady state for $t < 0$:

so

$$i_L(0^+) = i_L(0^-) = 0.5 \text{ A}$$

and

$$v_C(0^+) = v_C(0^-) = 2 \text{ V.}$$

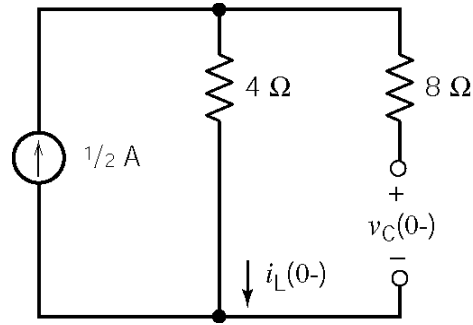

For $t > 0$:

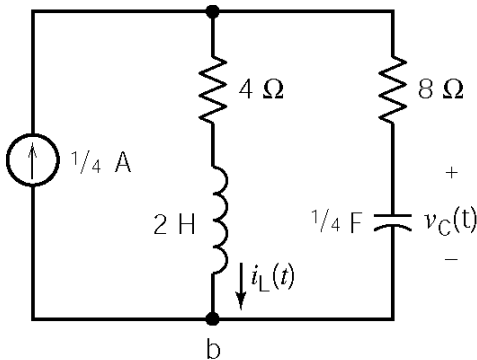

Apply KCL at node b to get:

$$\frac{1}{4} = i_L(t) + \frac{1}{4} \frac{d}{dt} v_C(t) \Rightarrow i_L(t) = \frac{1}{4} - \frac{1}{4} \frac{d}{dt} v_C(t)$$

Apply KVL at the right-most mesh to get:

$$4 i_L(t) + 2 \frac{d}{dt} i_L(t) = 8 \left(\frac{1}{4} \frac{d}{dt} v_C(t) \right) + v_C(t)$$

Use the substitution method to get

$$4 \left(\frac{1}{4} - \frac{1}{4} \frac{d}{dt} v_C(t) \right) + 2 \frac{d}{dt} \left(\frac{1}{4} - \frac{1}{4} \frac{d}{dt} v_C(t) \right) = 8 \left(\frac{1}{4} \frac{d}{dt} v_C(t) \right) + v_C(t)$$

or

$$2 = \frac{d^2}{dt^2} v_C(t) + 6 \frac{d}{dt} v_C(t) + 2 v_C(t)$$

The forced response will be a constant, $v_C = B$ so $2 = \frac{d^2}{dt^2} B + 6 \frac{d}{dt} B + 2B \Rightarrow B = 1 \text{ V.}$

To find the natural response, consider the characteristic equation:

$$0 = s^2 + 6s + 2 = (s + 5.65)(s + 0.35)$$

The natural response is

$$v_n = A_1 e^{-5.65t} + A_2 e^{-0.35t}$$

so

$$v_C(t) = A_1 e^{-5.65t} + A_2 e^{-0.35t} + 1$$

Then

$$i_L(t) = \frac{1}{4} + \frac{1}{4} \frac{d}{dt} v_C(t) = \frac{1}{4} + 1.41 A_1 e^{-5.65t} + 0.0875 A_2 e^{-0.35t}$$

At $t=0^+$

$$2 = v_C(0^+) = A_1 + A_2 + 1$$

$$\frac{1}{2} = i_L(0^+) = \frac{1}{4} + 1.41A_1 + 0.0875A_2$$

so $A_1 = 0.123$ and $A_2 = 0.877$. Finally

$$v_C(t) = 0.123 e^{-5.65t} + 0.877 e^{-0.35t} + 1 \text{ V}$$

P9.9-9

After $t = 0$

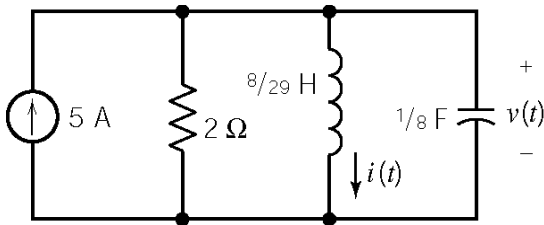

The inductor current and voltage are related by

$$v(t) = L \frac{di(t)}{dt} \quad (1)$$

Apply KCL at the top node to get

$$C \frac{dv(t)}{dt} + i(t) + \frac{v(t)}{2} = 5 \quad (2)$$

Using the operator $s = \frac{d}{dt}$, and substituting (1) into (2) yields $(s^2 + 4s + 29) i(t) = 5$.

The characteristic equation is $s^2 + 4s + 29 = 0$. The characteristic roots are $s_{1,2} = -2 \pm j5$.

The natural response is of the form $i_n(t) = e^{-2t} [A \cos 5t + B \sin 5t]$.

Try a forced response of the form $i_f(t) = A$. Substituting into the differential equation gives $A = 5$. Therefore $i_f(t) = 5 \text{ A}$.

The complete response is $i(t) = 5 + e^{-2t} [A \cos 5t + B \sin 5t]$ where the constants A and B are yet to be evaluated using the initial condition:

$$\begin{aligned} i(0) = 0 &= A + 5 \Rightarrow A = -5 \\ 0 = v(0) = L \frac{di(0)}{dt} &\Rightarrow \frac{di(0)}{dt} = 0 = -2A + 5B \Rightarrow B = \frac{2A}{5} = -2 \end{aligned}$$

Finally, $i(t) = 5 + e^{-2t} [-5 \cos 5t - 2 \sin 5t] \text{ A}$.

P9.9-10

Assume that the circuit is at steady before $t = 0$.

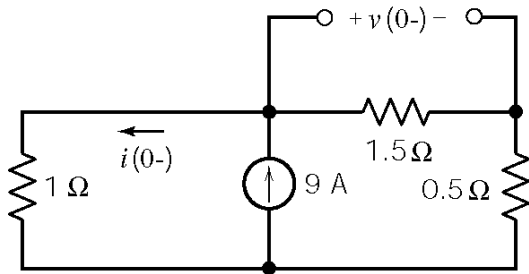

$$i(0^+) = i(0^-) = \frac{2}{2+1} \times 9 = 6 \text{ A}$$

$$v(0^+) = v(0^-) = \frac{1}{2+1} \times 9 \times 1.5 = 4.5 \text{ V}$$

After $t = 0$:

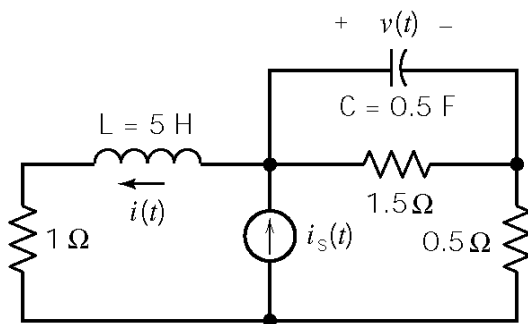

Apply KCL at the top node of the current source to get

$$i(t) + 0.5 \frac{dv(t)}{dt} + \frac{v(t)}{1.5} = i_s(t) \quad (1)$$

Apply KVL and KCL to get

$$v(t) + \left[0.5 \frac{dv(t)}{dt} + \frac{v(t)}{1.5} \right] 0.5 = \frac{5di(t)}{dt} + i(t) \quad (2)$$

Solving for $i(t)$ in (1) and plugging into (2) yields

$$\frac{d^2v(t)}{dt^2} + \frac{49}{30} \frac{dv(t)}{dt} + \frac{4}{5}v(t) = \frac{2}{5}i_s(t) + 2 \frac{di_s(t)}{dt} \quad \text{where } i_s(t) = 9 + 3e^{-2t} \text{ A}$$

Using the operator $s = \frac{d}{dt}$, the characteristic equation is $s^2 + \frac{49}{30}s + \frac{4}{5} = 0$ and the characteristic roots are $s_{1,2} = -.817 \pm j.365$. The natural response has the form

$$v_n(t) = e^{-0.817t} [A_1 \cos(0.365t) + A_2 \sin(0.365t)]$$

Try a forced response of the form $v_f(t) = B_0 + B_1 e^{-2t}$. Substituting into the differential equations gives $B_0 = 4.5$ and $B_1 = -7.04$. The complete response has the form

$$v(t) = e^{-0.817t} [A_1 \cos(0.365t) + A_2 \sin(0.365t)] + 4.5 - 7.04e^{-2t}$$

Next, consider the initial conditions:

$$v(0) = 4.5 = A_1 + 4.5 - 7.04 \Rightarrow A_1 = 7.04$$

$$\frac{dv(0)}{dt} = 2i_s(0) - 2i(0) - \frac{4}{3}v(0) = 2(9+3) - 2(6) - \frac{4}{3}(4.5) = 6$$

$$6 = \frac{dv(0)}{dt} = -0.817A_1 + 0.365A_2 + 14.08 \Rightarrow A_2 = -6.38$$

So the voltage is given by

$$v(t) = e^{-0.817t} [7.04 \cos(0.365t) + A_2 \sin(0.365t)] + 4.5 - 7.04e^{-2t}$$

Next the current given by

$$i(t) = i_s(t) - \frac{v(t)}{1.5} - 0.5 \frac{dv(t)}{dt}$$

Finally

$$i(t) = \underline{e^{-0.817t} [2.37 \cos(0.365t) + 7.14 \sin(0.365t)] + 6 + 0.65e^{-2t} \text{ A}}$$

P9.9-11

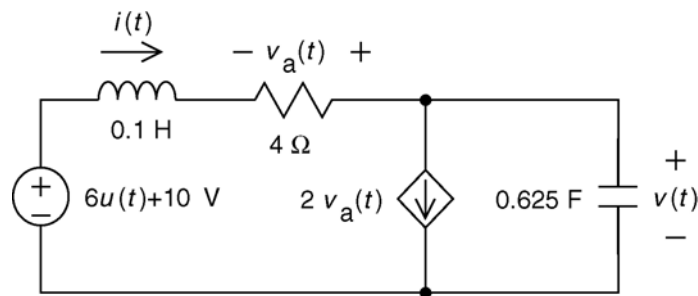

First, find the steady state response for $t < 0$. The input is constant so the capacitor will act like an open circuit at steady state, and the inductor will act like a short circuit.

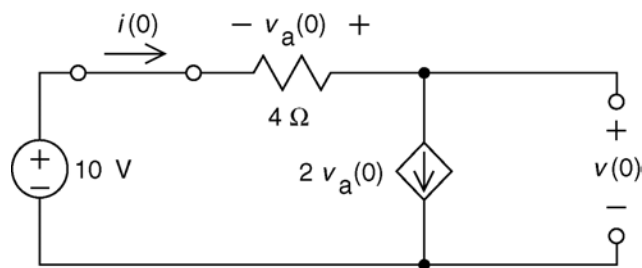

$$v_a(0^-) = -4i(0^-)$$

$$i(0^-) = 2v_a(0^-) = 2(-4i(0^-)) \Rightarrow i(0^-) = 0 \text{ A}$$

and

$$v(0^-) = 10 \text{ V}$$

For $t > 0$

Apply KCL at node 2:

$$\frac{v_a}{R} + K v_a + C \frac{d}{dt} v = 0$$

KCL at node 1 and Ohm's Law:

$$v_a = -Ri$$

so

$$\frac{d}{dt} v = \frac{1+KR}{C} i$$

Apply KVL to the outside loop: $L \frac{d}{dt} i + Ri + v - V_s = 0$

After some algebra:

$$\frac{d^2}{dt^2} v + \frac{R}{L} \frac{d}{dt} v + \frac{1+KR}{LC} v = \frac{1+KR}{LC} V_s \Rightarrow \frac{d^2}{dt^2} v + 40 \frac{d}{dt} v + 144 v = 2304$$

The forced response will be a constant, $v_f = B$ so

$$\frac{d^2}{dt^2} B + (40) \frac{d}{dt} B + (144) B = 2304 \Rightarrow B = 16 \text{ V}$$

The characteristic equation is $s^2 + 40s + 144 = 0 \Rightarrow s_{1,2} = -4, -36$.

Then $v(t) = A_1 e^{-4t} + A_2 e^{-36t} + 16$.

Using the initial conditions:

$$\left. \begin{aligned} 10 = v(0^+) &= A_1 e^0 + A_2 e^0 + 16 \Rightarrow A_1 + A_2 = -6 \\ 0 = \frac{d}{dt} v(0^+) &= -4 A_1 e^0 - 36 A_2 e^0 \Rightarrow -4 A_1 - 36 A_2 = 0 \end{aligned} \right\} \Rightarrow A_1 = -6.75 \text{ and } A_2 = 0.75$$

So

$$v(t) = 0.75 e^{-36t} - 6.75 e^{-4t} + 16 \text{ V for } t > 0$$

(checked using LNAP on 7/22/03)

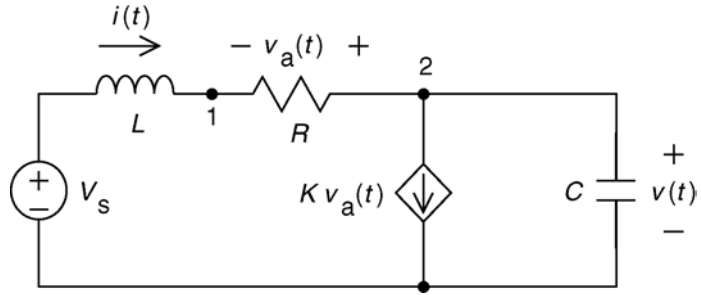

Section 9-10: State Variable Approach to Circuit Analysis

P9.10-1

At $t = 0^-$ the circuit is source free $\therefore i_L(0) = 0$ and $v(0) = 0$.

After $t = 0$

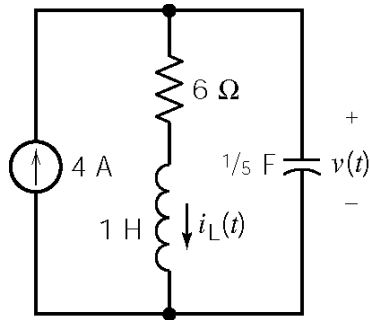

Apply KCL at the top node to get

$$i_L(t) + \frac{1}{5} \frac{dv(t)}{dt} = 4 \quad (1)$$

Apply KVL to the right mesh to get

$$v(t) - (1) \frac{di_L(t)}{dt} - 6 i_L(t) = 0 \quad (2)$$

Solving for $i_L(t)$ in (1) and plugging into (2) $\Rightarrow \frac{d^2v(t)}{dt^2} + 6 \frac{dv(t)}{dt} + 5v(t) = 120$.

The characteristic equation is $s^2 + 6s + 5 = 0$. The natural frequencies are $s_{1,2} = -1, -5$. The natural response has the form $v_n(t) = A_1 e^{-t} + A_2 e^{-5t}$. Try $v_f(t) = B$ as the forced response.

Substituting into the differential equation gives $B = 24$ so $v_f(t) = 24$ V. The complete response has the form $v(t) = A_1 e^{-t} + A_2 e^{-5t} + 24$.

Now consider the initial conditions. From (1) $\frac{dv(0)}{dt} = 20 - 5 i_L(0) = 20 \text{ V/s}$. Then

$$\left. \begin{aligned} v(0) = 0 &= A_1 + A_2 + 24 \\ \frac{dv(0)}{dt} = 20 &= -A_1 - 5A_2 \end{aligned} \right\} \Rightarrow A_1 = -25, A_2 = 1$$

Finally $v(t) = -25e^{-t} + e^{-5t} + 24$ V.

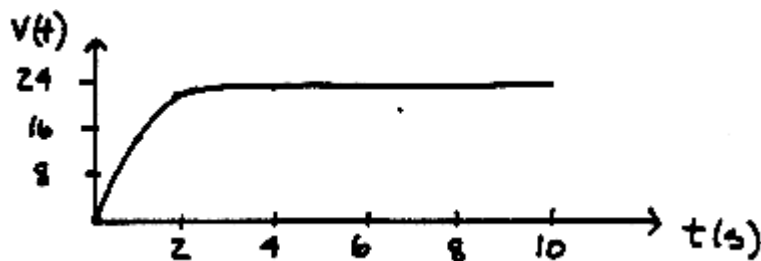

P9.10-2

Before $t = 0$ there are no sources in the circuit so $i_L(0) = 0$ and $v(0) = 0$.

After $t = 0$ we have:

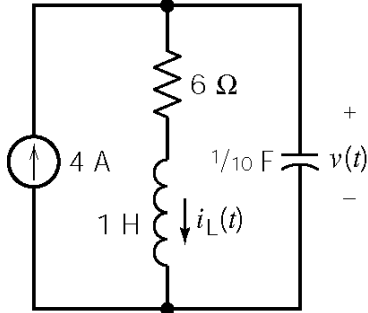

Apply KCL at the top node to get

$$i_L(t) = 4 - \frac{1}{10} \frac{dv(t)}{dt} \quad (1)$$

Apply KVL to the left mesh to get

$$v(t) - \frac{di_L(t)}{dt} - 6i_L(t) = 0 \quad (2)$$

Substituting $i_L(t)$ from (1) into (2) gives

$$\frac{d^2v(t)}{dt^2} + 6\frac{dv(t)}{dt} + 10v(t) = 240$$

The characteristic equation is $s^2 + 6s + 10 = 0$. The natural frequencies are $s_{1,2} = -3 \pm j$. The natural response has the form $v_n(t) = e^{-3t} [A_1 \cos t + A_2 \sin t]$. Try $v_f(t) = B$ as the forced response. Substituting into the differential equation gives $B = 24$ so $v_f(t) = 24$ V. The complete response has the form $v(t) = e^{-3t} [A_1 \cos t + A_2 \sin t] + 24$.

Now consider the initial conditions. From (1) $\frac{dv(0)}{dt} = 40 - 10 i_L(0) = 40 \text{ V/s}$. Then

$$v(0) = 0 = A_1 + 24 \Rightarrow A_1 = -24$$

$$\frac{dv(0)}{dt} = 40 = -3A_1 + A_2 = 72 + A_2 \Rightarrow A_2 = -32$$

Finally, $v(t) = e^{-3t} [-24 \cos t - 32 \sin t] + 24$ V

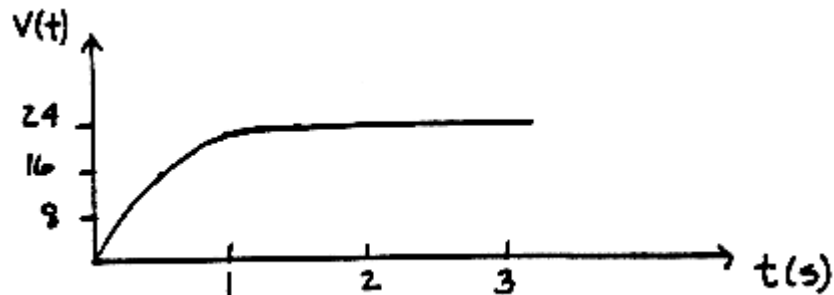

P9.10-3

Assume that the circuit is at steady state before $t = 0$ so $i_L(0) = -3$ A and $v(0) = 0$ V .

After $t = 0$ we have

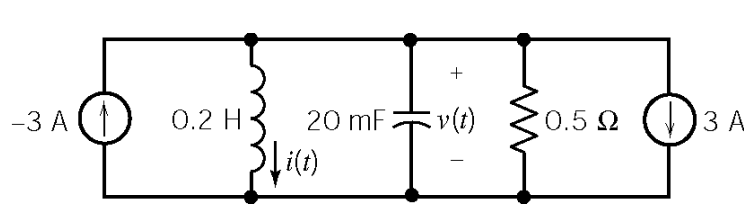

$$\text{KCL: } i(t) + C \frac{dv(t)}{dt} + \frac{v(t)}{R} + 6 = 0$$

$$\text{KVL: } v(t) = L \frac{di(t)}{dt}$$

$$i(t) + C \frac{d}{dt} \left[L \frac{di(t)}{dt} \right] + \frac{1}{R} \left[L \frac{di(t)}{dt} \right] + 6 = 0$$

$$\frac{d^2 i(t)}{dt^2} + \frac{1}{RC} \frac{di(t)}{dt} + \frac{1}{LC} i(t) = \frac{-6}{LC} \Rightarrow \frac{d^2 i(t)}{dt^2} + 100 \frac{di(t)}{dt} + 250 i(t) = -1500$$

The characteristic equation is $s^2 + 100s + 250 = 0$. The natural frequencies are

$s_{1,2} = -2.57, -97.4$. The natural response has the form $i_n(t) = A_1 e^{-2.57t} + A_2 e^{-97.4t}$. Try

$i_f(t) = B$ as the forced response. Substituting into the differential equation gives $B = -6$ so

$i_f(t) = -6$ A. The complete response has the form $i(t) = A_1 e^{-2.57t} + A_2 e^{-97.4t} - 6$.

Now consider the initial conditions:

$$\left. \begin{aligned} i(0) &= A_1 + A_2 - 6 = -3 \\ \frac{di(0)}{dt} &= 0 = -2.57A_1 - 97.4A_2 \end{aligned} \right\} \begin{aligned} A_1 &= 3.081 \\ A_2 &= -0.081 \end{aligned}$$

Finally:

$$i(t) = 3.081 e^{-2.57t} - 0.081 e^{-97.4t} - 6 \text{ A}$$

$$v(t) = .2 \frac{di(t)}{dt} = -1.58 e^{-2.57t} + 1.58 e^{-97.4t} \text{ V}$$

P9.10-4

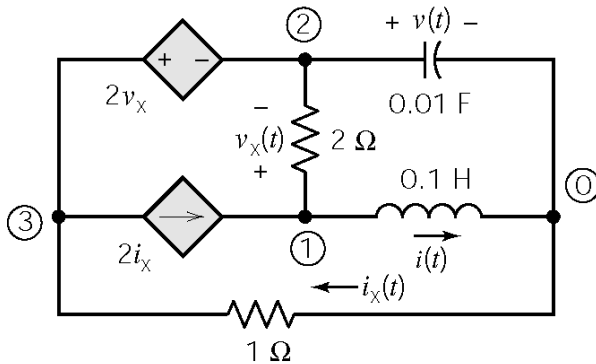

(Encircled numbers are node numbers.)

Apply KCL to the supernode corresponding to the dependent voltage source to get

$$i_x(t) - 2i_x(t) - 0.01 \frac{dv(t)}{dt} + \frac{v_x(t)}{2} = 0$$

Apply KCL at node 1 to get

$$i(t) - 2i_x(t) + \frac{v_x(t)}{2} = 0$$

Apply KVL to the top-right mesh to get

$$v_x(t) + v(t) - 0.1 \frac{di(t)}{dt} = 0$$

Apply KVL to the outside loop to get $i_x(t) = -2v_x(t) - v(t)$.

Eliminate $i_x(t)$ to get

$$\frac{5}{2}v_x(t) + v(t) - 0.01 \frac{dv(t)}{dt} = 0$$

$$i(t) + \frac{9}{2}v_x(t) + 2v(t) = 0$$

$$v_x(t) = -v(t) + 0.01 \frac{di(t)}{dt}$$

Then eliminate $v_x(t)$ to get

$$-1.5v(t) - 0.01 \frac{dv(t)}{dt} + 0.25 \frac{di(t)}{dt} = 0$$

$$-2.5v(t) + i(t) + 0.45 \frac{di(t)}{dt} = 0$$

Using the operator $s = \frac{d}{dt}$ we have

$$(-1.5 - .01s)v(t) + (.25s) i(t) = 0$$

$$(-2.5)v(t) + (1 + .45s) i(t) = 0$$

The characteristic equation is $s^2 + 13.33s + 333.33 = 0$. The natural frequencies

are $s_1, s_2 = -6.67 \pm j 17$. The natural response has the form $v_n(t) = [A \cos 17t + B \sin 17t] e^{-6.67t}$.

The forced response is $v_f(t) = 0$. The complete response has the form

$$v(t) = [A \cos 17t + B \sin 17t] e^{-6.67t}$$

The given initial conditions are $i(0) = 0$ and $v(0) = 10$ V. Then

$$v(0)=10=A \quad \text{and} \quad \frac{dv(0)}{dt}=-111=-6.67A+17B \Rightarrow B=-2.6$$

Finally $\underline{i(t) = [3.27 \sin 17t] e^{-6.67t} \text{ A}}$.

(Checked using LNAP on 7/22/03)

P9.10-5

Assume that the circuit is at steady state before $t = 0$ so $v(0) = 10$ V and $i_L(0) = \frac{v(0)}{3} = \frac{10}{3}$ A.

The switch is open when $0 < t < 0.5$ s

For this series RLC circuit we have:

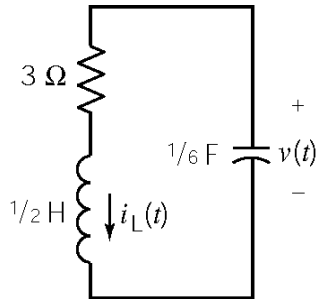

$$\alpha = \frac{R}{2L} = 3 \quad \text{and} \quad \omega_0^2 = \frac{1}{LC} = 12$$

$$-\alpha \pm \sqrt{\alpha^2 - \omega_0^2} = s_{1,2} = -3 \pm j\sqrt{3}$$

The natural response has the form $v_n(t) = e^{-3t} (A \cos 1.73t + B \sin 1.73t)$. There is no source so $v_f(t) = 0$. The complete response has the form $v(t) = e^{-3t} (A \cos 1.73t + B \sin 1.73t)$.

Next

$$\left. \begin{array}{l} v(0) = 10 = A \\ \frac{dv(0)}{dt} = -\frac{i(0)}{C} = -\frac{10/3}{1/6} = -20 = -3A + 1.73B \end{array} \right\} \Rightarrow \begin{cases} A = 10 \\ B = 5.77 \end{cases}$$

so

$$v(t) = e^{-3t} (10 \cos 1.73t + 5.77 \sin 1.73t) \text{ V}$$

$$i(t) = e^{-3t} (3.33 \cos 1.73t - 5.77 \sin 1.73t) \text{ A}$$

In particular,

$$v(0.5) = e^{-1.5} \left(10 \cos \frac{1.73}{2} + 5.77 \sin \frac{1.73}{2} \right) = 0.2231 \times (6.4864 + 4.3915) = 2.43 \text{ V}$$

and

$$i(0.5) = e^{-1.5} \left(3.33 \cos \frac{1.73}{2} - 5.77 \sin \frac{1.73}{2} \right) = 0.2231 \times (2.1600 - 4.3915) = -0.50 \text{ A}$$

The switch is closed when $t > 0.5$ s

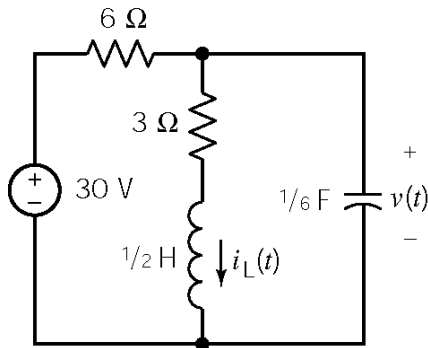

Apply KCL at the top node:

$$\begin{aligned} \frac{v(t)-30}{6} + i_L(t) + \frac{1}{6} \frac{dv(t)}{dt} &= 0 \\ \Rightarrow i_L(t) &= 5 - \frac{1}{6} \left(v(t) + \frac{dv(t)}{dt} \right) \\ \Rightarrow \frac{di_L(t)}{dt} &= -\frac{1}{6} \left(\frac{dv(t)}{dt} + \frac{d^2v(t)}{dt^2} \right) \end{aligned}$$

Apply KVL to the right mesh:

$$v(t) = 3i_L(t) + \frac{1}{2} \frac{di_L(t)}{dt}$$

The circuit is represented by the differential equation

$$\frac{d^2v(t)}{dt^2} + 7 \frac{dv(t)}{dt} + 18v(t) = 180$$

The characteristic equation is $0 = s^2 + 7s + 18$. The natural frequencies are $s_{1,2} = -3.7 \pm j 2.4$.

The natural response has the form $v_n(t) = e^{-3.5t} (A \cos 2.4t + B \sin 2.4t)$. The forced response is $v_f(t) = 10$ V. The complete response has the form $v(t) = e^{-3.5t} (A \cos 2.4t + B \sin 2.4t) + 10$.

Next

$$v(0.5) = e^{-3.5 \times 0.5} (A \cos 1.2 + B \sin 1.2) = 0.063 A + 0.162 B$$

$$\begin{aligned} \frac{dv(0.5)}{dt} &= e^{-3.5 \times 0.5} [(-3.5A + 2.4B) \cos 1.2 - (3.5B + 2.4A) \sin 1.2] \\ &= e^{-3.5 \times 0.5} (-3.5 \cos 1.2 - 2.4 \sin 1.2) A + e^{-3.5 \times 0.5} (2.4 \cos 1.2 - 3.5 \sin 1.2) B \\ &= -0.6091A - 0.4158B \end{aligned}$$

Using the initial conditions yields

$$\left. \begin{aligned} 2.43 = v(0.5) &= 0.063 A + 0.162 B \\ \frac{dv(0.5)}{dt} = -\frac{i(0.5)}{C} = -\frac{-1/2}{1/6} = 3 &= -0.6091A - 0.4158B \end{aligned} \right\} \Rightarrow \begin{aligned} A &= -20.65 \\ B &= 23.03 \end{aligned}$$

Finally

$$v(t) = e^{-3.5t} (-20.65 \cos 2.4t + 23.03 \sin 2.4t) + 10$$

In summary

$$v(t) = \begin{cases} e^{-3t} (10 \cos 1.73t + 5.77 \sin 1.73t) \text{ V} & 0 < t < 0.5 \\ e^{-3.5t} (-20.65 \cos 2.4t + 23.03 \sin 2.4t) + 10 \text{ V} & 0.5 < t \end{cases}$$

Section 9-11: Roots in the Complex Plane

P9.11-1

After $t = 0$

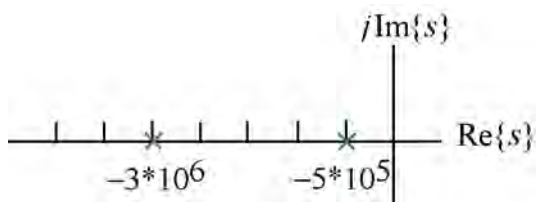
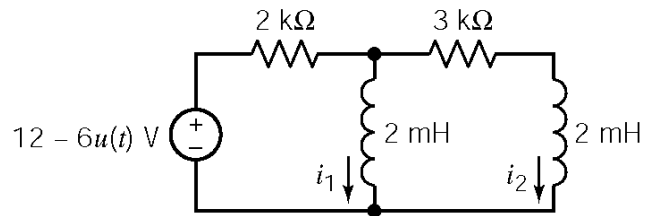

$$i_1 + i_2 + \frac{2 \times 10^{-3} \frac{di_1}{dt} - 6}{2000} = 0$$

$$2 \times 10^{-3} \frac{di_1}{dt} = 3000i_2 + 2 \times 10^{-3} \frac{di_2}{dt}$$

Using the operator $s = \frac{d}{dt}$ yields

$$\begin{pmatrix} 2000 + 2 \times 10^{-3}s & 2000 \\ 2 \times 10^{-3}s & 3000 + 2 \times 10^{-3}s \end{pmatrix} \begin{pmatrix} i_1 \\ i_2 \end{pmatrix} = \begin{pmatrix} 6 \\ 0 \end{pmatrix}$$

$$s^2 + 3.5 \times 10^6 s + 1.5 \times 10^{12} = 0$$

$$\Rightarrow s_{1,2} = -5 \times 10^5, -3 \times 10^6$$

P9.11-2

From P9.7-1

$$s^2 + \frac{1}{RC}s + \frac{1}{LC} = 0 \Rightarrow s^2 + \frac{1}{(250)(5 \times 10^{-6})}s + \frac{1}{(0.8)(5 \times 10^{-6})} = 0$$

$$\Rightarrow s^2 + 800s + 250000 = 0$$

$$s_{1,2} = 400 \pm j 300$$

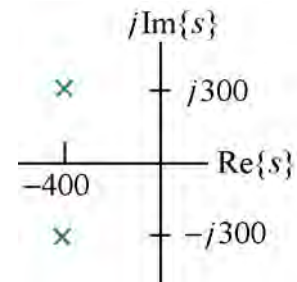

P9.11-3

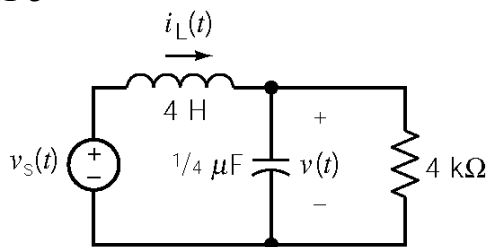

$$\text{KCL: } i_L(t) = \frac{1}{4} \times 10^{-6} \frac{dv(t)}{dt} + \frac{v(t)}{4000}$$

$$\text{KVL: } v_s(t) = 4 \frac{di_L(t)}{dt} + v(t)$$

$$v_s(t) = 4 \frac{d}{dt} \left(\frac{1}{4} \times 10^{-6} \frac{dv(t)}{dt} + \frac{v(t)}{4000} \right) + v(t) = 10^{-6} \frac{d^2v(t)}{dt^2} + 10^{-3} \frac{dv(t)}{dt} + v(t)$$

Characteristic equation: $s^2 + 10^3 s + 10^6 = 0$

Characteristic roots: $s_{1,2} = -500 \pm j 866$

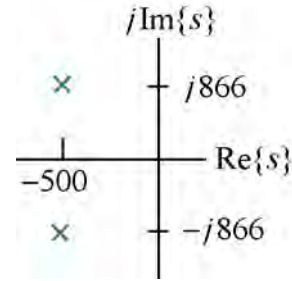

P9.11-4

Before $t = 0$ the voltage source voltage is 0 V so $v_b(0+) = v_b(0-) = 0$ V and $i(0+) = i(0-) = 0$ A. Apply KCL at node a to get

$$\frac{v_a(0+) - 36}{12} - i(0+) + \frac{v_a(0+) - v_b(0+)}{6} = 0 \Rightarrow v_a(0+) + 2v_a(0+) = 36 \Rightarrow v_a(0) = 12 \text{ V}$$

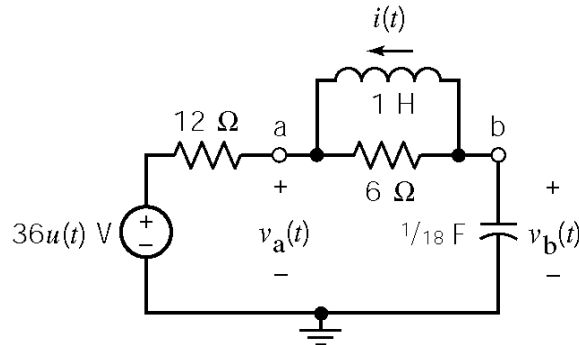

After $t = 0$ the node equations are:

$$-\frac{v_a(t) - v_s(t)}{12} + \frac{1}{L} \int_0^t (v_b(\tau) - v_a(\tau)) d\tau + \frac{v_b(t) - v_a(t)}{6} = 0$$

$$C \frac{dv_b(t)}{dt} + \frac{v_b(t) - v_a(t)}{6} + \frac{1}{L} \int_0^t (v_b(\tau) - v_a(\tau)) d\tau = 0$$

Using the operator $s = \frac{d}{dt}$ we have

$$\left(\frac{1}{12} + \frac{1}{6} + \frac{1}{s} \right) v_a(t) + \left(-\frac{1}{6} - \frac{1}{s} \right) v_b(t) = \frac{v_s(t)}{12}$$

$$\left(-\frac{1}{6} - \frac{1}{s} \right) v_a(t) + \left(\frac{1}{18} s + \frac{1}{6} + \frac{1}{s} \right) v_b(t) = 0$$

Using Cramer's rule

$$(s^2 + 5s + 6) v_b(t) = (s + 6) v_s(t) = (s + 6) (36) \quad (36)$$

The characteristic equation is $s^2 + 5s + 6 = 0$. The natural frequencies are $s_{1,2} = -2, -3$. The natural response has the form $v_n(t) = A_1 e^{-2t} + A_2 e^{-3t}$. Try $v_f(t) = B$ as the forced response. Substituting into the differential equation gives $B = 36$ so $v_f(t) = 36$ V. The complete response has the form $v_b(t) = A_1 e^{-2t} + A_2 e^{-3t} + 36$.

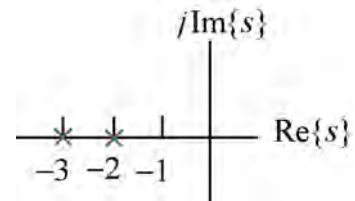

Next

$$v_b(0^+) = 36 + A_1 + A_2$$

$$\frac{dv_b}{dt}(0^+) = -2A_1 - 3A_2$$

Apply KCL at node a to get

$$\frac{1}{18} \frac{dv_b(t)}{dt} + \frac{v_b(t) - v_a(t)}{6} + i(t) = 0$$

At $t = 0^+$

$$\frac{1}{18} (-2A_1 - 3A_2) = \frac{1}{18} \frac{dv_b(0^+)}{dt} = \frac{v_a(0^+) - v_b(0^+)}{6} - i(0^+) = \frac{12 - 0}{6} - 0 = 2$$

So

$$\left. \begin{aligned} 0 = v_b(0^+) = 36 + A_1 + A_2 \\ \frac{1}{18} (-2A_1 - 3A_2) = 2 \end{aligned} \right\} \Rightarrow A_1 = -72, A_2 = 36$$

Finally

$$\underline{v_b(t) = 36 - 72e^{-2t} + 36e^{-3t} \text{ V for } t \geq 0}$$

PSpice Problems

SP 9-1

Make three copies of the circuit: one for each set of parameter values. (Cut and paste, but be sure to edit the labels of the parts so, for example, there is only one R1.)

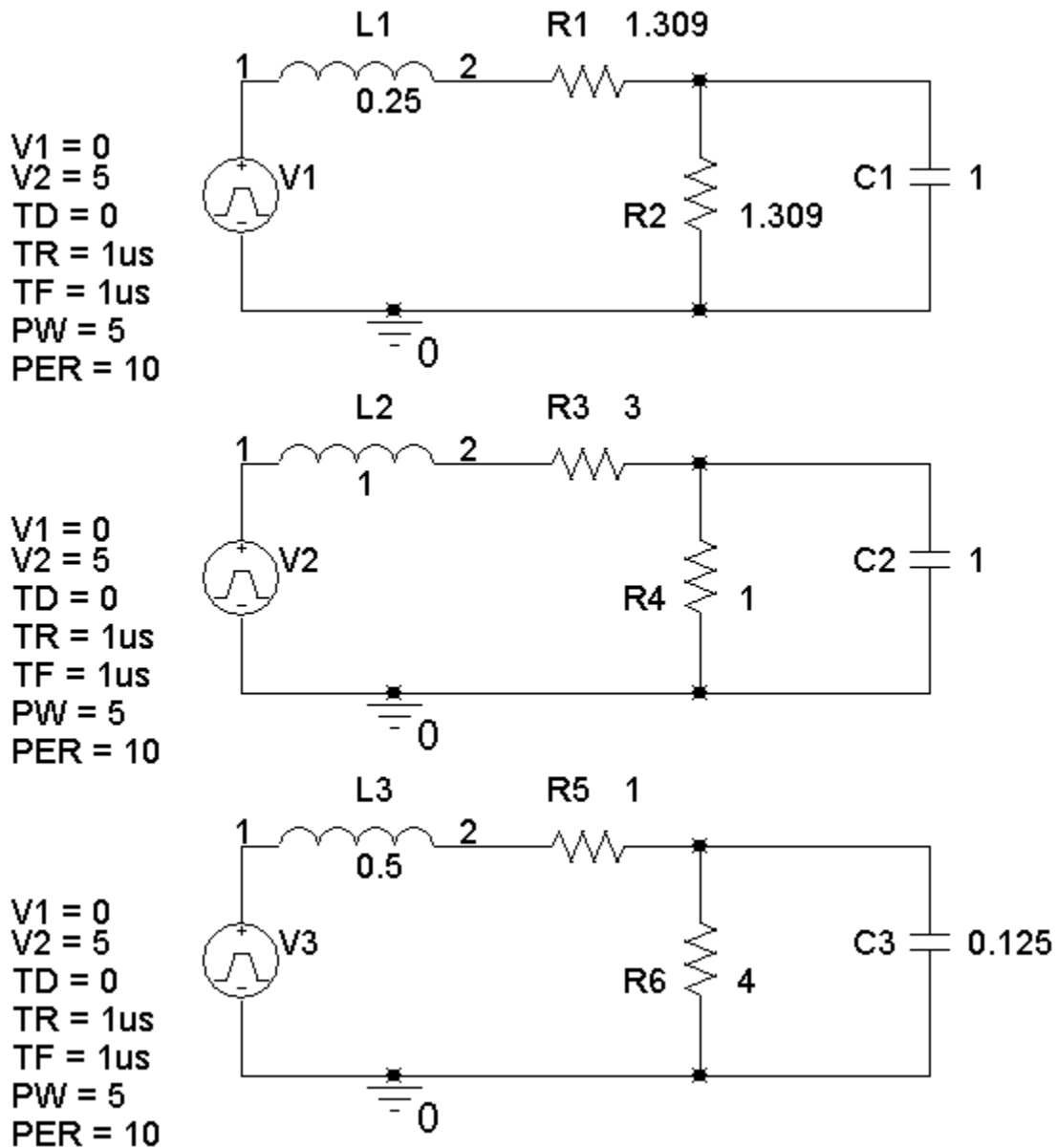

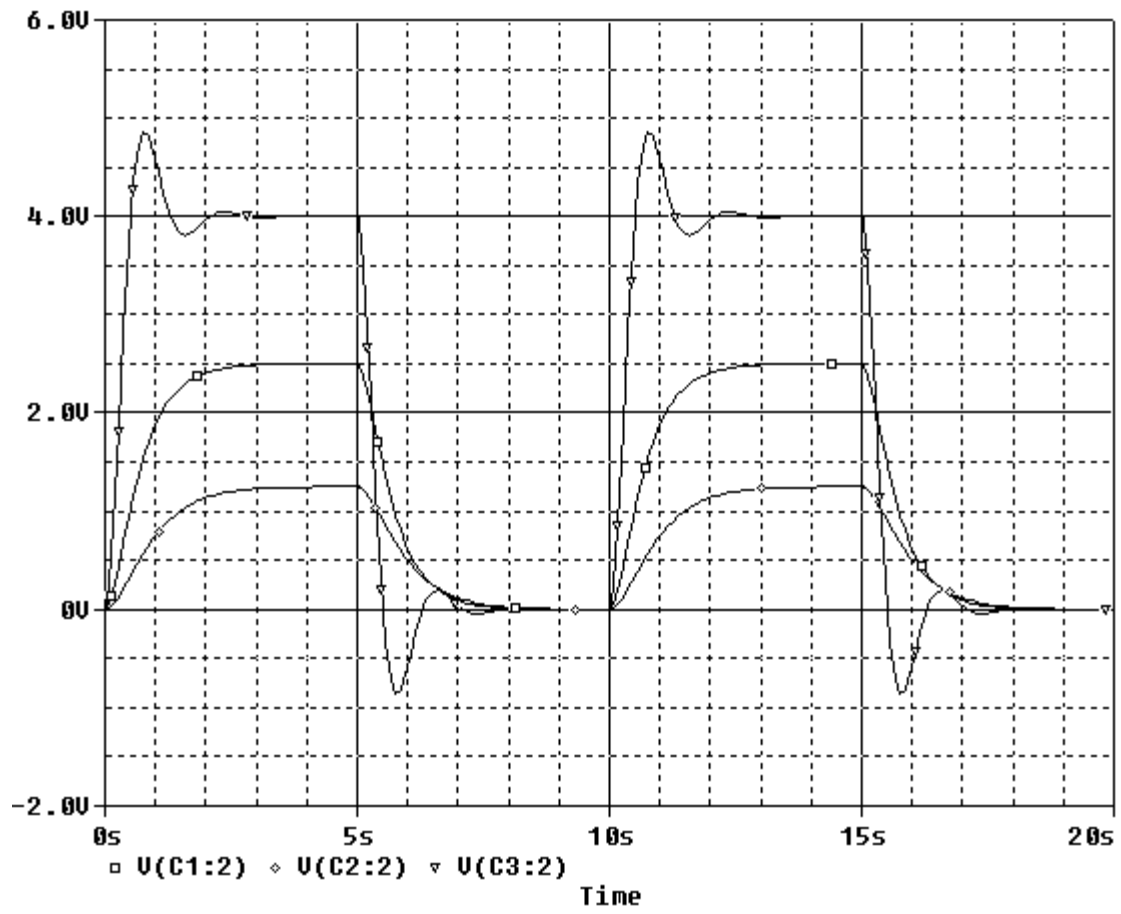

V(C1:2), V(C2:2) and V(C3:2) are the capacitor voltages, listed from top to bottom.

SP 9-2

Make three copies of the circuit: one for each set of parameter values. (Cut and paste, but be sure to edit the labels of the parts so, for example, there is only one R1.)

V1 = 0
 V2 = 5
 TD = 0
 TR = 1us
 TF = 1us
 PW = 5
 PER = 10

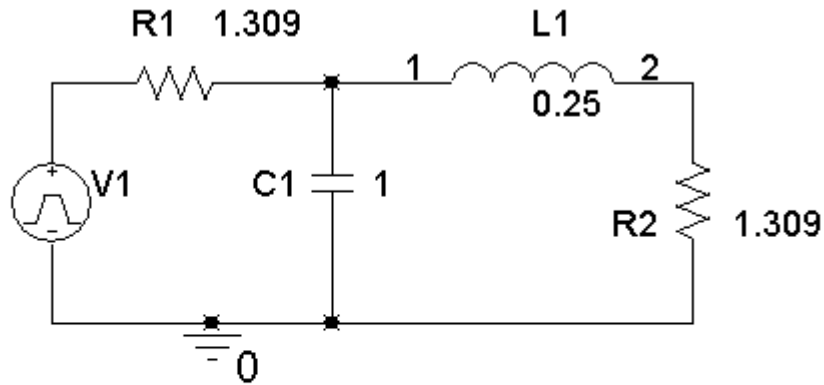

V1 = 0
 V2 = 5
 TD = 0
 TR = 1us
 TF = 1us
 PW = 5
 PER = 10

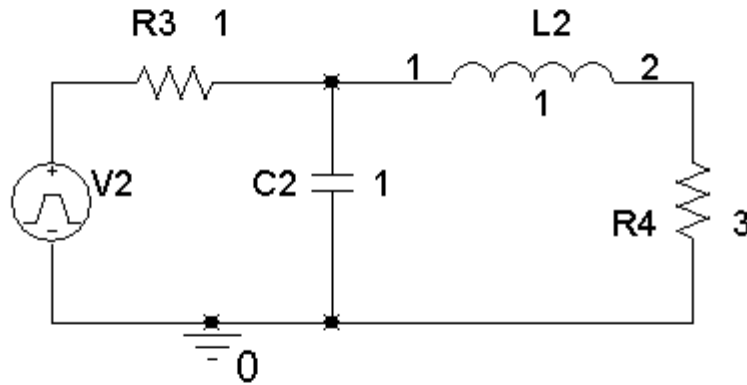

V1 = 0
 V2 = 5
 TD = 0
 TR = 1us
 TF = 1us
 PW = 5
 PER = 10

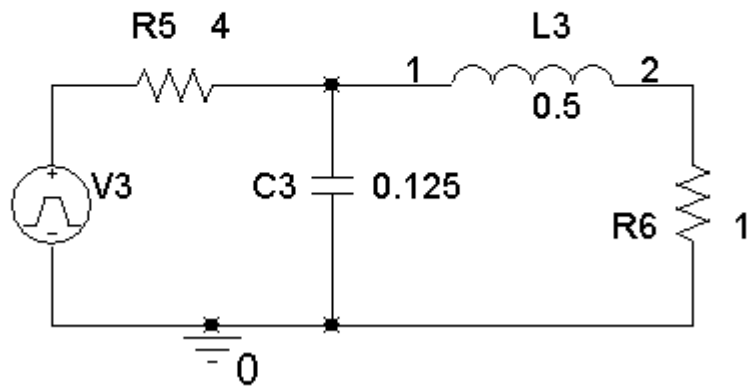

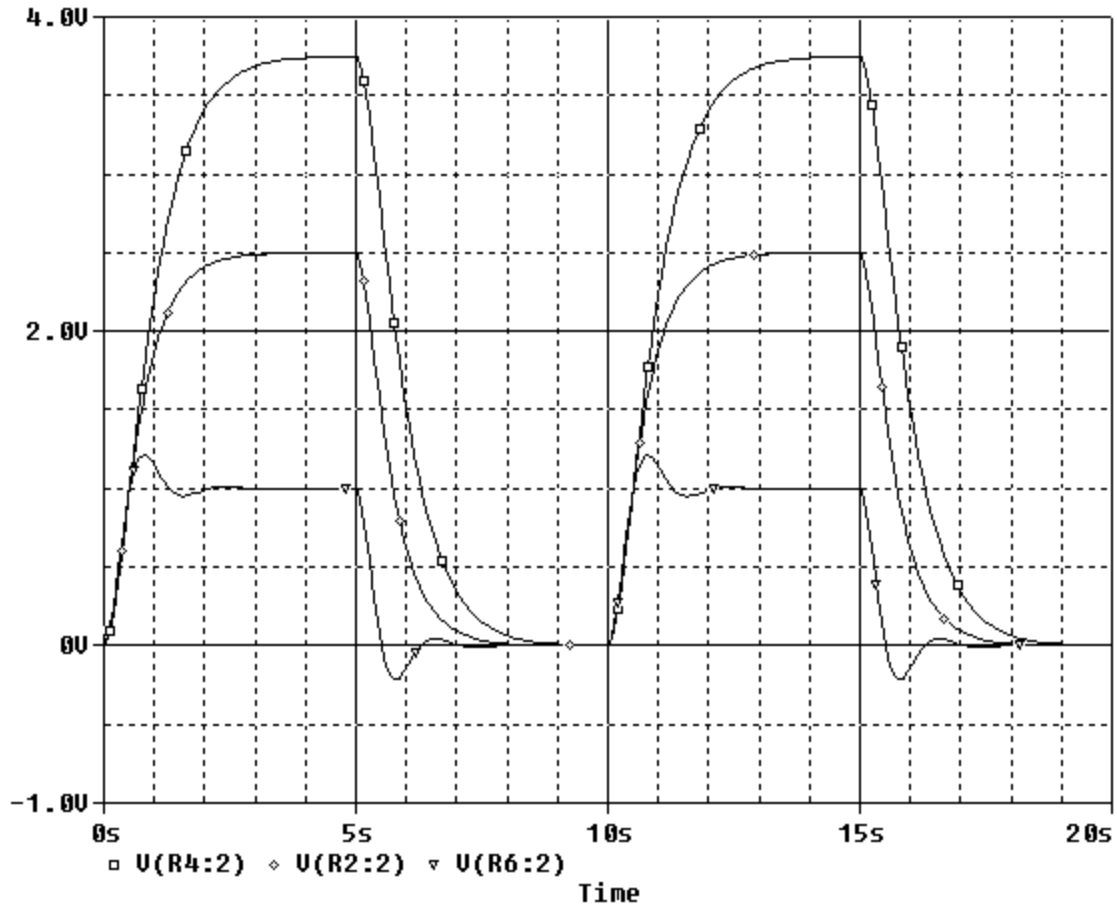

V(R2:2), V(R4:2) and V(R6:2) are the output voltages, listed from top to bottom.

SP 9-3

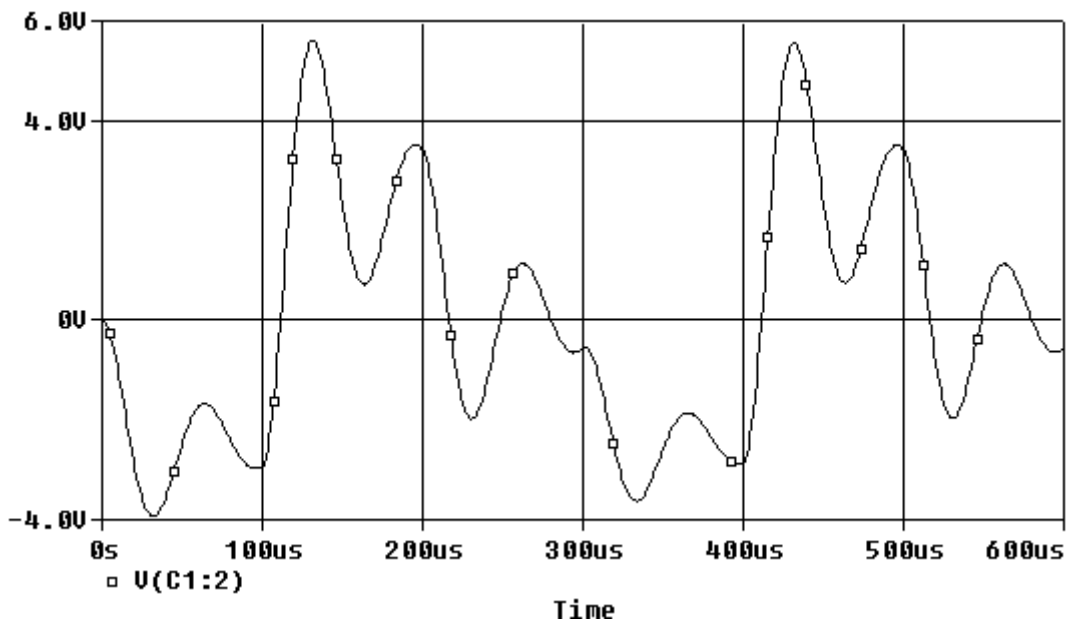
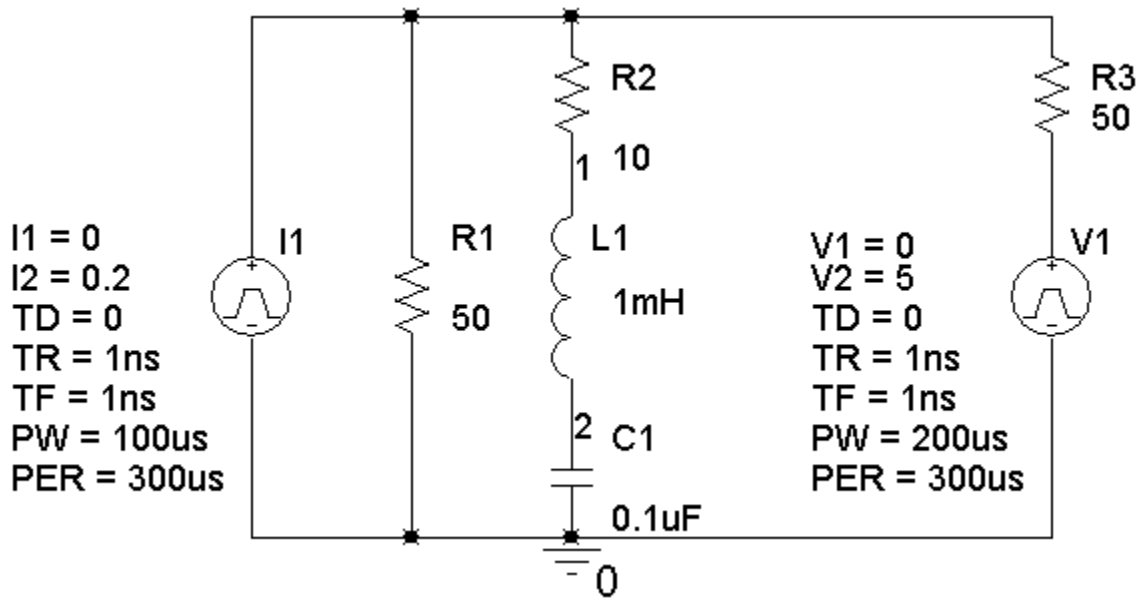

SP 9-4

V1 = 0
 V2 = 5
 TD = 0
 TR = 1ns
 TF = 1ns
 PW = 3
 PER = 5

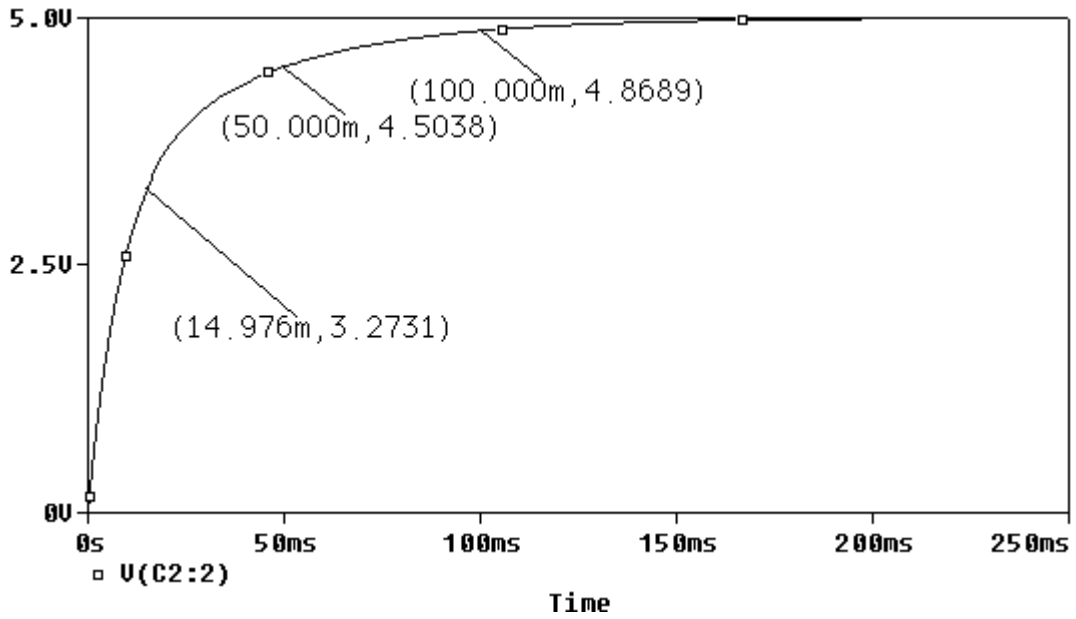
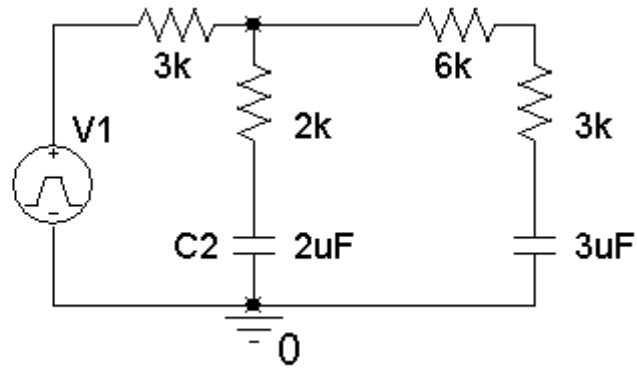

Verification Problems

VP 9-1

This problem is similar to the verification example in this chapter. First, check the steady-state inductor current

$$i(t) = \frac{v_s(t)}{100} = \frac{25}{100} = 250 \text{ mA}$$

This agrees with the value of 250.035 mA shown on the plot. Next, the plot shows an underdamped response. That requires

$$12 \times 10^{-3} = L < 4R^2C = 4(100)^2(2 \times 10^{-6}) = 8 \times 10^{-2}$$

This inequality is satisfied, which also agrees with the plot.

The damped resonant frequency is given by

$$\omega_d = \sqrt{\frac{1}{LC} - \left(\frac{1}{2RC}\right)^2} = \sqrt{\frac{1}{(2 \times 10^{-6})(12 \times 10^{-3})} - \left(\frac{1}{2(100)(2 \times 10^{-6})}\right)^2} = 5.95 \times 10^3$$

The plot indicates a maxima at 550.6 μs and a minima at 1078.7 μs . The period of the damped oscillation is

$$T_d = 2(1078.7 \mu\text{s} - 550.6 \mu\text{s}) = 1056.2 \mu\text{s}$$

Finally, check that

$$5.95 \times 10^3 = \omega_d = \frac{2\pi}{T_d} = \frac{2\pi}{1056.2 \times 10^{-6}} = 5.949 \times 10^3$$

The value of ω_d determined from the plot agrees with the value obtained from the circuit.

The plot is correct.

VP 9-2

This problem is similar to the verification example in this chapter. First, check the steady-state inductor current.

$$i(t) = \frac{v_s(t)}{100} = \frac{15}{100} = 150 \text{ mA}$$

This agrees with the value of 149.952 mA shown on the plot.

Next, the plot shows an underdamped response. This requires

$$8 \times 10^{-3} = L < 4R^2C = 4(100)^2(0.2 \times 10^{-6}) = 8 \times 10^{-3}$$

This inequality is not satisfied. The values in the circuit would produce a critically damped, not underdamped, response.

This plot is not correct.

Design Problems

DP 9-1

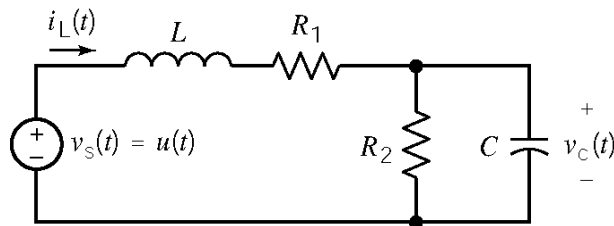

When the circuit reaches steady state after $t = 0$, the capacitor acts like an open circuit and the inductor acts like a short circuit. Under these conditions

$$v_C(\infty) = \frac{R_2}{R_1 + R_2} 1$$

The specifications require that $v_C(\infty) = \frac{1}{2}$ so

$$\frac{1}{2} = \frac{R_2}{R_1 + R_2} \Rightarrow R_1 = R_2$$

Next, represent the circuit by a 2nd order differential equation:

KCL at the top node of R_2 gives:

$$\frac{v_C(t)}{R_2} + C \frac{d}{dt} v_C(t) = i_L(t)$$

KVL around the outside loop gives:

$$v_s(t) = L \frac{d}{dt} i_L(t) + R_1 i_L(t) + v_C(t)$$

Use the substitution method to get

$$\begin{aligned}
 v_s(t) &= L \frac{d}{dt} \left(\frac{v_c(t)}{R_2} + C \frac{d}{dt} v_c(t) \right) + R_1 \left(\frac{v_c(t)}{R_2} + C \frac{d}{dt} v_c(t) \right) + v_c(t) \\
 &= LC \frac{d^2}{dt^2} v_c(t) + \left(\frac{L}{R_2} + R_1 C \right) \frac{d}{dt} v_c(t) + \left(1 + \frac{R_1}{R_2} \right) v_c(t)
 \end{aligned}$$

The characteristic equation is

$$s^2 + \left(\frac{1}{R_2 C} + \frac{R_1}{L} \right) s + \left(\frac{1 + \frac{R_1}{R_2}}{LC} \right) = s^2 + 6s + 8 = (s + 2)(s + 4) = 0$$

Equating coefficients of like powers of s :

$$\frac{1}{R_2 C} + \frac{R_1}{L} = 6 \quad \text{and} \quad \frac{1 + \frac{R_1}{R_2}}{LC} = 8$$

Using $R_1 = R_2 = R$ gives

$$\frac{1}{RC} + \frac{R}{L} = 6 \quad \Rightarrow \quad \frac{1}{LC} = 4$$

These equations do not have a unique solution. Try $C = 1$ F. Then $L = \frac{1}{4}$ H and

$$\frac{1}{R} + 4R = 6 \quad \Rightarrow \quad R^2 - \frac{3}{2}R + \frac{1}{4} = 0 \quad \Rightarrow \quad R = 1.309 \Omega \text{ or } R = 0.191 \Omega$$

Pick $R = 1.309 \Omega$. Then

$$v_c(t) = \frac{1}{2} + A_1 e^{-2t} + A_2 e^{-4t} \text{ V}$$

$$i_L(t) = \frac{v_c(t)}{1.309} + \frac{d}{dt} v_c(t) = -1.236 A_1 e^{-2t} - 3.236 A_2 e^{-4t} + 0.3819$$

At $t = 0^+$

$$0 = v_c(0^+) = A_1 + A_2 + 0.5$$

$$0 = i_L(0^+) = -1.236 A_1 - 3.236 A_2 + 0.3819$$

Solving these equations gives $A_1 = -1$ and $A_2 = 0.5$, so

$$v_c(t) = \frac{1}{2} - e^{-2t} + \frac{1}{2} e^{-4t} \text{ V}$$

DP 9-2

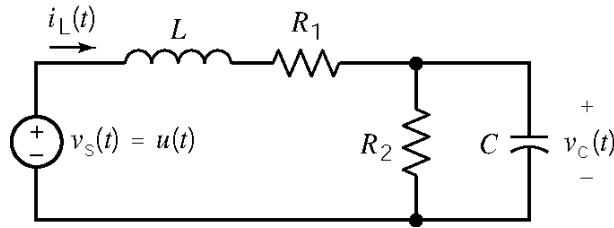

When the circuit reaches steady state after $t = 0$, the capacitor acts like an open circuit and the inductor acts like a short circuit. Under these conditions

$$v_C(\infty) = \frac{R_2}{R_1 + R_2} 1$$

The specifications require that $v_C(\infty) = \frac{1}{4}$ so

$$\frac{1}{4} = \frac{R_2}{R_1 + R_2} \Rightarrow 3R_2 = R_1$$

Next, represent the circuit by a 2nd order differential equation:

KCL at the top node of R_2 gives:
$$\frac{v_C(t)}{R_2} + C \frac{d}{dt} v_C(t) = i_L(t)$$

KVL around the outside loop gives:
$$v_s(t) = L \frac{d}{dt} i_L(t) + R_1 i_L(t) + v_C(t)$$

Use the substitution method to get

$$\begin{aligned} v_s(t) &= L \frac{d}{dt} \left(\frac{v_C(t)}{R_2} + C \frac{d}{dt} v_C(t) \right) + R_1 \left(\frac{v_C(t)}{R_2} + C \frac{d}{dt} v_C(t) \right) + v_C(t) \\ &= LC \frac{d^2}{dt^2} v_C(t) + \left(\frac{L}{R_2} + R_1 C \right) \frac{d}{dt} v_C(t) + \left(1 + \frac{R_1}{R_2} \right) v_C(t) \end{aligned}$$

The characteristic equation is

$$s^2 + \left(\frac{1}{R_2 C} + \frac{R_1}{L} \right) s + \left(\frac{1 + \frac{R_1}{R_2}}{LC} \right) = s^2 + 4s + 4 = (s + 2)^2 = 0$$

Equating coefficients of like powers of s :

$$\frac{1}{R_2 C} + \frac{R_1}{L} = 4 \quad \text{and} \quad \frac{1 + \frac{R_1}{R_2}}{LC} = 4$$

Using $R_2 = R$ and $R_1 = 3R$ gives

$$\frac{1}{RC} + \frac{3R}{L} = 4 \Rightarrow \frac{1}{LC} = 1$$

These equations do not have a unique solution. Try $C = 1$ F. Then $L = 1$ H and

$$\frac{1}{R} + 3R = 4 \Rightarrow R^2 - \frac{4}{3}R + \frac{1}{3} = 0 \Rightarrow R = 1 \Omega \text{ or } R = \frac{1}{3} \Omega$$

Pick $R = 1 \Omega$. Then $R_1 = 3 \Omega$ and $R_2 = 1 \Omega$.

$$v_c(t) = \frac{1}{4} + (A_1 + A_2 t) e^{-2t} \text{ V}$$

$$i_L(t) = v_c(t) + \frac{d}{dt} v_c(t) = \frac{1}{4} + ((A_2 - A_1) - A_2 t) e^{-2t}$$

At $t = 0^+$

$$0 = v_c(0^+) = A_1 + \frac{1}{4}$$

$$0 = i_L(0^+) = \frac{1}{4} + A_2 - A_1$$

Solving these equations gives $A_1 = -0.25$ and $A_2 = -0.5$, so

$$v_c(t) = \frac{1}{4} - \left(\frac{1}{4} + \frac{1}{2} t \right) e^{-2t} \text{ V}$$

DP 9-3

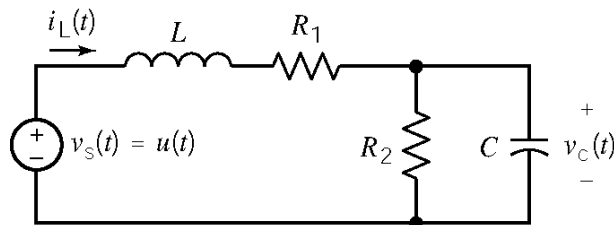

When the circuit reaches steady state after $t = 0$, the capacitor acts like an open circuit and the inductor acts like a short circuit. Under these conditions

$$v_c(\infty) = \frac{R_2}{R_1 + R_2} 1$$

The specifications require that $v_c(\infty) = \frac{4}{5}$ so

$$\frac{4}{5} = \frac{R_2}{R_1 + R_2} \Rightarrow 4R_1 = R_2$$

Next, represent the circuit by a 2nd order differential equation:

KCL at the top node of R_2 gives:
$$\frac{v_C(t)}{R_2} + C \frac{d}{dt} v_C(t) = i_L(t)$$

KVL around the outside loop gives:
$$v_s(t) = L \frac{d}{dt} i_L(t) + R_1 i_L(t) + v_C(t)$$

Use the substitution method to get

$$\begin{aligned} v_s(t) &= L \frac{d}{dt} \left(\frac{v_C(t)}{R_2} + C \frac{d}{dt} v_C(t) \right) + R_1 \left(\frac{v_C(t)}{R_2} + C \frac{d}{dt} v_C(t) \right) + v_C(t) \\ &= LC \frac{d^2}{dt^2} v_C(t) + \left(\frac{L}{R_2} + R_1 C \right) \frac{d}{dt} v_C(t) + \left(1 + \frac{R_1}{R_2} \right) v_C(t) \end{aligned}$$

The characteristic equation is

$$s^2 + \left(\frac{1}{R_2 C} + \frac{R_1}{L} \right) s + \left(\frac{1 + \frac{R_1}{R_2}}{LC} \right) = s^2 + 4s + 20 = (s + 2 - j4)(s + 2 + j4) = 0$$

Equating coefficients of like powers of s :

$$\frac{1}{R_2 C} + \frac{R_1}{L} = 4 \quad \text{and} \quad \frac{1 + \frac{R_1}{R_2}}{LC} = 20$$

Using $R_1 = R$ and $R_2 = 4R$ gives

$$\frac{1}{4RC} + \frac{R}{L} = 4 \quad \text{and} \quad \frac{1}{LC} = 20$$

These equations do not have a unique solution. Try $C = \frac{1}{8}$ F. Then $L = \frac{1}{2}$ H and

$$\frac{2}{R} + 2R = 4 \Rightarrow R^2 - 2R + 1 = 0 \Rightarrow R = 1 \Omega$$

Then $R_1 = 1 \Omega$ and $R_2 = 4 \Omega$. Next

$$v_C(t) = 0.8 + e^{-2t} (A_1 \cos 4t + A_2 \sin 4t) \text{ V}$$

$$i_L(t) = \frac{v_C(t)}{4} + \frac{1}{8} \frac{d}{dt} v_C(t) = 0.2 + \frac{A_2}{2} e^{-2t} \cos 4t - \frac{A_1}{2} e^{-2t} \sin 4t$$

At $t = 0^+$

$$0 = v_C(0^+) = 0.8 + A_1$$

$$0 = i_L(0^+) = 0.2 + \frac{A_2}{2}$$

Solving these equations gives $A_1 = -0.8$ and $A_2 = -0.4$, so

$$v_C(t) = 0.8 - e^{-2t} (0.8 \cos 4t + 0.4 \sin 4t) \text{ V}$$

DP 9-4

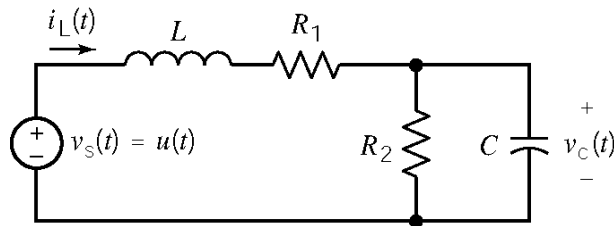

When the circuit reaches steady state after $t = 0$, the capacitor acts like an open circuit and the inductor acts like a short circuit. Under these conditions

$$v_C(\infty) = \frac{R_2}{R_1 + R_2} 1$$

The specifications require that $v_C(\infty) = \frac{1}{2}$ so

$$\frac{1}{2} = \frac{R_2}{R_1 + R_2} \Rightarrow R_1 = R_2$$

Next, represent the circuit by a 2nd order differential equation:

KCL at the top node of R_2 gives:
$$\frac{v_C(t)}{R_2} + C \frac{d}{dt} v_C(t) = i_L(t)$$

KVL around the outside loop gives:
$$v_s(t) = L \frac{d}{dt} i_L(t) + R_1 i_L(t) + v_C(t)$$

Use the substitution method to get

$$\begin{aligned}
 v_s(t) &= L \frac{d}{dt} \left(\frac{v_C(t)}{R_2} + C \frac{d}{dt} v_C(t) \right) + R_1 \left(\frac{v_C(t)}{R_2} + C \frac{d}{dt} v_C(t) \right) + v_C(t) \\
 &= LC \frac{d^2}{dt^2} v_C(t) + \left(\frac{L}{R_2} + R_1 C \right) \frac{d}{dt} v_C(t) + \left(1 + \frac{R_1}{R_2} \right) v_C(t)
 \end{aligned}$$

The characteristic equation is

$$s^2 + \left(\frac{1}{R_2 C} + \frac{R_1}{L} \right) s + \left(\frac{1 + \frac{R_1}{R_2}}{LC} \right) = s^2 + 4s + 20 = (s + 2 - j4)(s + 2 + j4) = 0$$

Equating coefficients of like powers of s :

$$\frac{1}{R_2 C} + \frac{R_1}{L} = 4 \quad \text{and} \quad \frac{1 + \frac{R_1}{R_2}}{LC} = 20$$

Using $R_1 = R_2 = R$ gives

$$\frac{1}{RC} + \frac{R}{L} = 4 \quad \text{and} \quad \frac{1}{LC} = 20$$

Substituting $L = \frac{1}{10C}$ into the first equation gives

$$(RC)^2 - \frac{4}{10}(RC) + \frac{1}{10} = 0 \Rightarrow RC = \frac{0.4 \pm \sqrt{0.4^2 - 4(0.1)}}{2}$$

Since RC cannot have a complex value, the specification cannot be satisfied.

DP 9-5

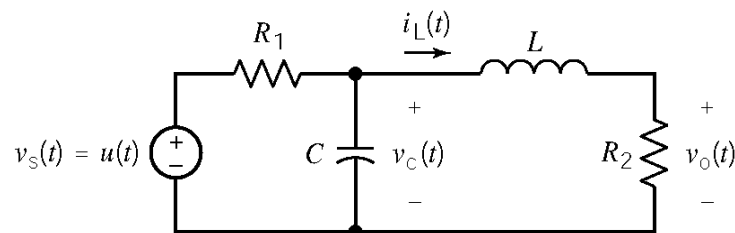

When the circuit reaches steady state after $t = 0$, the capacitor acts like an open circuit and the inductor acts like a short circuit. Under these conditions

$$v_C(\infty) = \frac{R_2}{R_1 + R_2} 1, \quad i_L(\infty) = \frac{1}{R_1 + R_2} \quad \text{and} \quad v_o(\infty) = \frac{R_2}{R_1 + R_2} 1$$

The specifications require that $v_o(\infty) = \frac{1}{2}$ so

$$\frac{1}{2} = \frac{R_2}{R_1 + R_2} \Rightarrow R_1 = R_2$$

Next, represent the circuit by a 2nd order differential equation:

KVL around the right-hand mesh gives: $v_C(t) = L \frac{d}{dt} i_L(t) + R_2 i_L(t)$

KCL at the top node of the capacitor gives: $\frac{v_s(t) - v_C(t)}{R_1} - C \frac{d}{dt} v_C(t) = i_L(t)$

Use the substitution method to get

$$\begin{aligned} v_s(t) &= R_1 C \frac{d}{dt} \left(L \frac{d}{dt} i_L(t) + R_2 i_L(t) \right) + \left(L \frac{d}{dt} i_L(t) + R_2 i_L(t) \right) + R_1 i_L(t) \\ &= R_1 L C \frac{d^2}{dt^2} i_L(t) + (L + R_1 R_2 C) \frac{d}{dt} i_L(t) + (R_1 + R_2) i_L(t) \end{aligned}$$

Using $i_L(t) = \frac{v_o(t)}{R_2}$ gives

$$v_s(t) = \frac{R_1}{R_2} L C \frac{d^2}{dt^2} v_o(t) + \left(\frac{L}{R_2} + R_1 C \right) \frac{d}{dt} v_o(t) + \left(\frac{R_1 + R_2}{R_2} \right) v_o(t)$$

The characteristic equation is

$$s^2 + \left(\frac{1}{R_1 C} + \frac{R_2}{L} \right) s + \left(\frac{1 + \frac{R_2}{R_1}}{LC} \right) = s^2 + 6s + 8 = (s + 2)(s + 4) = 0$$

Equating coefficients of like powers of s :

$$\frac{1}{R_1 C} + \frac{R_2}{L} = 6 \quad \text{and} \quad \frac{1 + \frac{R_2}{R_1}}{LC} = 8$$

Using $R_1 = R_2 = R$ gives

$$\frac{1}{R C} + \frac{R}{L} = 6 \Rightarrow \frac{1}{LC} = 4$$

These equations do not have a unique solution. Try $C = 1$ F. Then $L = \frac{1}{4}$ H and

$$\frac{1}{R} + 4R = 6 \Rightarrow R^2 - \frac{3}{2}R + \frac{1}{4} = 0 \Rightarrow R = 1.309 \Omega \text{ or } R = 0.191 \Omega$$

Pick $R = 1.309 \Omega$. Then

$$v_o(t) = \frac{1}{2} + A_1 e^{-2t} + A_2 e^{-4t} \text{ V}$$

$$i_L(t) = \frac{v_o(t)}{1.309} = \frac{1}{2.618} + \frac{A_1}{1.309} e^{-2t} + \frac{A_2}{1.309} e^{-4t} \text{ V}$$

$$v_C(t) = 1.309 i_L(t) + \frac{1}{4} \frac{d}{dt} i_L(t) = \frac{1}{2} + 0.6167 A_1 e^{-2t} + 0.2361 A_2 e^{-4t}$$

At $t = 0^+$

$$0 = i_L(0^+) = \frac{1}{2.618} + \frac{A_1}{1.309} + \frac{A_2}{1.309}$$

$$0 = v_C(0^+) = \frac{1}{2} + 0.6167 A_1 + 0.2361 A_2$$

Solving these equations gives $A_1 = -1$ and $A_2 = 0.5$, so

$$v_o(t) = \frac{1}{2} - e^{-2t} + \frac{1}{2} e^{-4t} \text{ V}$$

DP 9-6

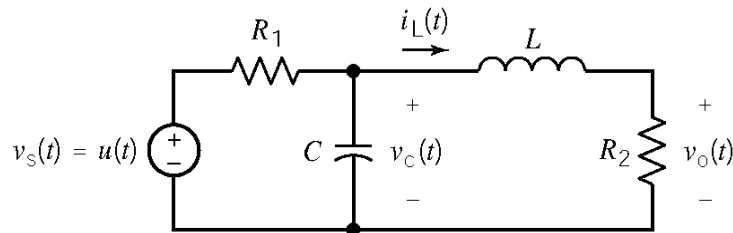

When the circuit reaches steady state after $t = 0$, the capacitor acts like an open circuit and the inductor acts like a short circuit. Under these conditions

$$v_C(\infty) = \frac{R_2}{R_1 + R_2} 1, \quad i_L(\infty) = \frac{1}{R_1 + R_2} \quad \text{and} \quad v_o(\infty) = \frac{R_2}{R_1 + R_2} 1$$

The specifications require that $v_o(\infty) = \frac{3}{4}$ so

$$\frac{3}{4} = \frac{R_2}{R_1 + R_2} \Rightarrow 3R_1 = R_2$$

Next, represent the circuit by a 2nd order differential equation:

KVL around the right-hand mesh gives:
$$v_C(t) = L \frac{d}{dt} i_L(t) + R_2 i_L(t)$$

KCL at the top node of the capacitor gives:
$$\frac{v_s(t) - v_C(t)}{R_1} - C \frac{d}{dt} v_C(t) = i_L(t)$$

Use the substitution method to get

$$\begin{aligned} v_s(t) &= R_1 C \frac{d}{dt} \left(L \frac{d}{dt} i_L(t) + R_2 i_L(t) \right) + \left(L \frac{d}{dt} i_L(t) + R_2 i_L(t) \right) + R_1 i_L(t) \\ &= R_1 L C \frac{d^2}{dt^2} i_L(t) + (L + R_1 R_2 C) \frac{d}{dt} i_L(t) + (R_1 + R_2) i_L(t) \end{aligned}$$

Using $i_L(t) = \frac{v_o(t)}{R_2}$ gives

$$v_s(t) = \frac{R_1}{R_2} L C \frac{d^2}{dt^2} v_o(t) + \left(\frac{L}{R_2} + R_1 C \right) \frac{d}{dt} v_o(t) + \left(\frac{R_1 + R_2}{R_2} \right) v_o(t)$$

The characteristic equation is

$$s^2 + \left(\frac{1}{R_1 C} + \frac{R_2}{L} \right) s + \left(\frac{1 + \frac{R_2}{R_1}}{LC} \right) = s^2 + 4s + 4 = (s + 2)^2 = 0$$

Equating coefficients of like powers of s :

$$\frac{1}{R_1 C} + \frac{R_2}{L} = 4 \quad \text{and} \quad \frac{1 + \frac{R_2}{R_1}}{LC} = 4$$

Using $R_1 = R$ and $R_2 = 3R$ gives

$$\frac{1}{RC} + \frac{3R}{L} = 4 \quad \text{and} \quad \frac{1}{LC} = 1$$

These equations do not have a unique solution. Try $C = 1$ F. Then $L = 1$ H and

$$\frac{1}{R} + 3R = 4 \Rightarrow R^2 - \frac{4}{3}R + \frac{1}{3} = 0 \Rightarrow R = 1 \Omega \text{ or } R = \frac{1}{3} \Omega$$

Pick $R = 1 \Omega$. Then $R_1 = 1 \Omega$ and $R_2 = 3 \Omega$.

$$v_o(t) = \frac{3}{4} + (A_1 + A_2 t) e^{-2t} \text{ V}$$

$$i_L(t) = \frac{v_o(t)}{3} = \frac{1}{4} + \left(\frac{A_1}{3} + \frac{A_2}{3}t \right) e^{-2t} \text{ V}$$

$$v_C(t) = 3i_L(t) + \frac{d}{dt}i_L(t) = \frac{3}{4} + \left(\left(\frac{A_1}{3} + \frac{A_2}{3} \right) + \frac{A_2}{3}t \right) e^{-2t}$$

At $t = 0+$

$$0 = i_L(0+) = \frac{A_1}{3} + \frac{1}{4}$$

$$0 = v_C(0+) = \frac{3}{4} + \frac{A_1}{3} + \frac{A_2}{3}$$

Solving these equations gives $A_1 = -0.75$ and $A_2 = -1.5$, so

$$v_o(t) = \frac{3}{4} - \left(\frac{3}{4} + \frac{3}{2}t \right) e^{-2t} \text{ V}$$

DP 9-7

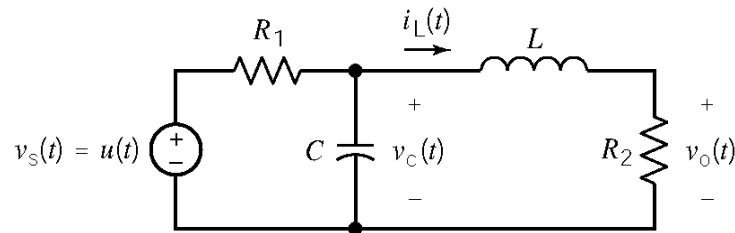

When the circuit reaches steady state after $t = 0$, the capacitor acts like an open circuit and the inductor acts like a short circuit. Under these conditions

$$v_C(\infty) = \frac{R_2}{R_1 + R_2} 1, \quad i_L(\infty) = \frac{1}{R_1 + R_2} \quad \text{and} \quad v_o(\infty) = \frac{R_2}{R_1 + R_2} 1$$

The specifications require that $v_o(\infty) = \frac{1}{5}$ so

$$\frac{1}{5} = \frac{R_2}{R_1 + R_2} \Rightarrow R_1 = 4R_2$$

Next, represent the circuit by a 2nd order differential equation:

KVL around the right-hand mesh gives:
$$v_C(t) = L \frac{d}{dt}i_L(t) + R_2 i_L(t)$$

KCL at the top node of the capacitor gives:
$$\frac{v_s(t) - v_C(t)}{R_1} - C \frac{d}{dt}v_C(t) = i_L(t)$$

Use the substitution method to get

$$\begin{aligned} v_s(t) &= R_1 C \frac{d}{dt} \left(L \frac{d}{dt} i_L(t) + R_2 i_L(t) \right) + \left(L \frac{d}{dt} i_L(t) + R_2 i_L(t) \right) + R_1 i_L(t) \\ &= R_1 L C \frac{d^2}{dt^2} i_L(t) + (L + R_1 R_2 C) \frac{d}{dt} i_L(t) + (R_1 + R_2) i_L(t) \end{aligned}$$

Using $i_L(t) = \frac{v_o(t)}{R_2}$ gives

$$v_s(t) = \frac{R_1}{R_2} L C \frac{d^2}{dt^2} v_o(t) + \left(\frac{L}{R_2} + R_1 C \right) \frac{d}{dt} v_o(t) + \left(\frac{R_1 + R_2}{R_2} \right) v_o(t)$$

The characteristic equation is

$$s^2 + \left(\frac{1}{R_1 C} + \frac{R_2}{L} \right) s + \left(\frac{1 + \frac{R_2}{R_1}}{L C} \right) = s^2 + 4s + 20 = (s + 2 - j4)(s + 2 + j4) = 0$$

Equating coefficients of like powers of s :

$$\frac{1}{R_1 C} + \frac{R_2}{L} = 4 \quad \text{and} \quad \frac{1 + \frac{R_2}{R_1}}{L C} = 20$$

Using $R_2 = R$ and $R_1 = 4R$ gives

$$\frac{1}{4R C} + \frac{R}{L} = 4 \quad \text{and} \quad \frac{1}{L C} = 16$$

These equations do not have a unique solution. Try $C = \frac{1}{8}$ F. Then $L = \frac{1}{2}$ H and

$$\frac{2}{R} + 2R = 4 \Rightarrow R^2 - 2R + 2 = 0 \Rightarrow R = 1 \Omega$$

Then $R_1 = 4 \Omega$ and $R_2 = 1 \Omega$. Next

$$v_o(t) = 0.2 + e^{-2t} (A_1 \cos 4t + A_2 \sin 4t) \text{ V}$$

$$i_L(t) = \frac{v_o(t)}{1} = 0.2 + e^{-2t} (A_1 \cos 4t + A_2 \sin 4t) \text{ V}$$

$$v_C(t) = i_L(t) + \frac{1}{2} \frac{d}{dt} i_L(t) = 0.2 + 2A_2 e^{-2t} \cos 4t - 2A_1 e^{-2t} \sin 4t$$

At $t = 0^+$

$$0 = i_L(0^+) = 0.2 + A_1$$

$$0 = v_C(0^+) = 0.2 + 2A_2$$

Solving these equations gives $A_1 = -0.8$ and $A_2 = -0.4$, so

$$v_C(t) = 0.2 - e^{-2t} (0.2 \cos 4t + 0.1 \sin 4t) \text{ V}$$

DP 9-8

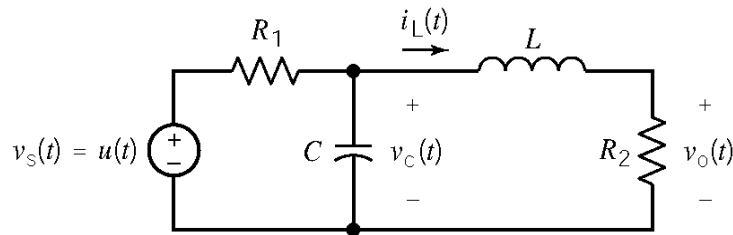

When the circuit reaches steady state after $t = 0$, the capacitor acts like an open circuit and the inductor acts like a short circuit. Under these conditions

$$v_C(\infty) = \frac{R_2}{R_1 + R_2} 1, \quad i_L(\infty) = \frac{1}{R_1 + R_2} \quad \text{and} \quad v_o(\infty) = \frac{R_2}{R_1 + R_2} 1$$

The specifications require that $v_C(\infty) = \frac{1}{2}$ so

$$\frac{1}{2} = \frac{R_2}{R_1 + R_2} \Rightarrow R_1 = R_2$$

Next, represent the circuit by a 2nd order differential equation:

KVL around the right-hand mesh gives:
$$v_C(t) = L \frac{d}{dt} i_L(t) + R_2 i_L(t)$$

KCL at the top node of the capacitor gives:
$$\frac{v_s(t) - v_C(t)}{R_1} - C \frac{d}{dt} v_C(t) = i_L(t)$$

Use the substitution method to get

$$v_s(t) = R_1 C \frac{d}{dt} \left(L \frac{d}{dt} i_L(t) + R_2 i_L(t) \right) + \left(L \frac{d}{dt} i_L(t) + R_2 i_L(t) \right) + R_1 i_L(t)$$

$$= R_1 L C \frac{d^2}{dt^2} i_L(t) + (L + R_1 R_2 C) \frac{d}{dt} i_L(t) + (R_1 + R_2) i_L(t)$$

Using $i_L(t) = \frac{v_o(t)}{R_2}$ gives

$$v_s(t) = \frac{R_1}{R_2} LC \frac{d^2}{dt^2} v_o(t) + \left(\frac{L}{R_2} + R_1 C \right) \frac{d}{dt} v_o(t) + \left(\frac{R_1 + R_2}{R_2} \right) v_o(t)$$

The characteristic equation is

$$s^2 + \left(\frac{1}{R_1 C} + \frac{R_2}{L} \right) s + \left(\frac{1 + \frac{R_2}{R_1}}{LC} \right) = s^2 + 4s + 20 = (s + 2 - j4)(s + 2 + j4) = 0$$

Equating coefficients of like powers of s :

$$\frac{1}{R_1 C} + \frac{R_2}{L} = 4 \quad \text{and} \quad \frac{1 + \frac{R_2}{R_1}}{LC} = 20$$

Using $R_1 = R_2 = R$ gives

$$\frac{1}{RC} + \frac{R}{L} = 4 \quad \Rightarrow \quad \frac{1}{LC} = 10$$

Substituting $L = \frac{1}{10C}$ into the first equation gives

$$(RC)^2 - \frac{4}{10}(RC) + \frac{1}{10} = 0 \quad \Rightarrow \quad RC = \frac{0.4 \pm \sqrt{0.4^2 - 4(0.1)}}{2}$$

Since RC cannot have a complex value, the specification cannot be satisfied.

DP 9-9

Let's simulate the three copies of the circuit simultaneously. Each copy uses a different value of the inductance.

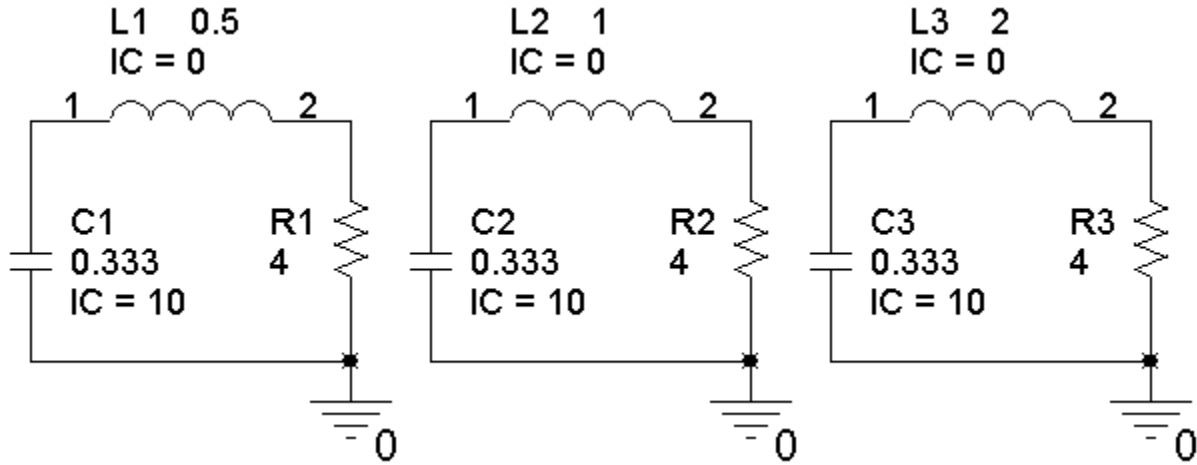

The PSpice transient response shows that when $L = 1$ H the inductor current has its maximum at approximately $t=0.5$ s.

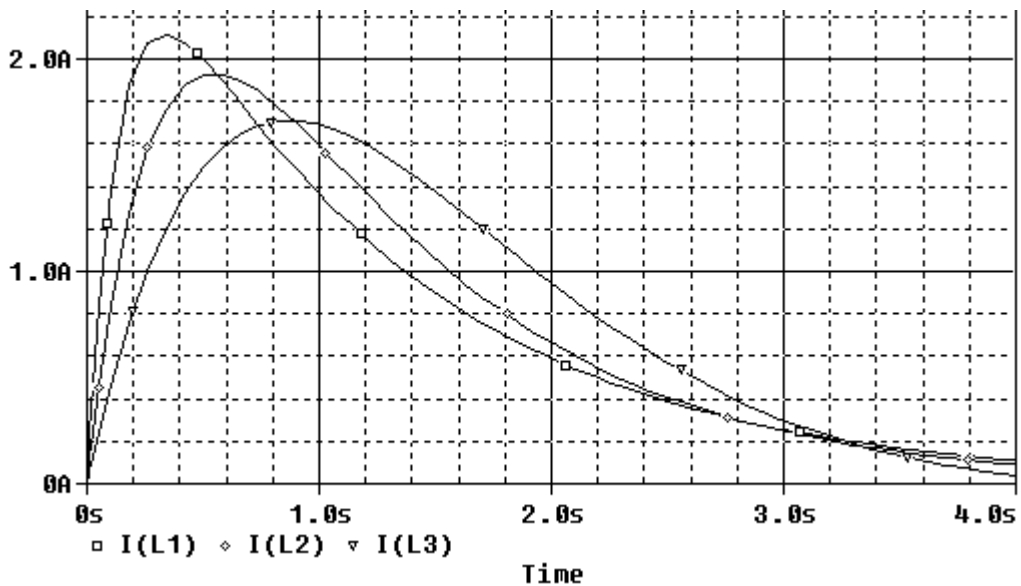

Consequently, we choose $L = 1$ H.

Chapter 10 – Sinusoidal Steady-State Analysis

Exercises

Ex. 10.3-1

- (a) $T = 2\pi / \omega = \underline{2\pi / 4}$
 (b) v leads i by $30 - (-70) = \underline{100^\circ}$

Ex. 10.3-2

$$v(t) = 3 \cos 4t + 4 \sin 4t = \sqrt{(3)^2 + (4)^2} \cos\left(4t - \tan^{-1}\left(\frac{4}{3}\right)\right) = \underline{5 \cos(4t - 53^\circ)}$$

Ex. 10.3-3

$$i(t) = -5 \cos 5t + 12 \sin 5t = \sqrt{(-5)^2 + (12)^2} \cos\left(5t - \left(180 + \tan^{-1}\left(\frac{12}{-5}\right)\right)\right) = \underline{13 \cos(5t - 112.6^\circ)}$$

Ex. 10.4-1

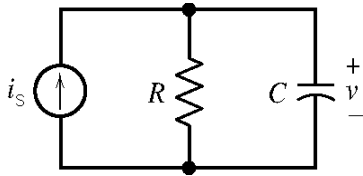

$$\text{KCL: } i_s(t) = \frac{v(t)}{R} + C \frac{d}{dt} v(t) \Rightarrow \frac{d}{dt} v(t) + \frac{v(t)}{RC} = \frac{I_m}{C} \cos \omega t$$

Try $v_f(t) = A \cos \omega t + B \sin \omega t$ & plug into above differential equation to get

$$-\omega A \sin \omega t + \omega B \cos \omega t + \frac{1}{RC} (A \cos \omega t + B \sin \omega t) = \frac{I_m}{C} \cos \omega t$$

Equating $\sin \omega t$ & $\cos \omega t$ terms yields

$$A = \frac{R I_m}{1 + \omega^2 R^2 C^2} \quad \text{and} \quad B = \frac{\omega R^2 C I_m}{1 + \omega^2 R^2 C^2}$$

Therefore

$$v_f(t) = \frac{R I_m}{1 + \omega^2 R^2 C^2} \cos \omega t + \frac{\omega R^2 C I_m}{1 + \omega^2 R^2 C^2} \sin \omega t = \frac{R I_m}{\sqrt{1 + \omega^2 R^2 C^2}} \cos[\omega t - \tan^{-1}(\omega RC)]$$

Ex. 10.4-2

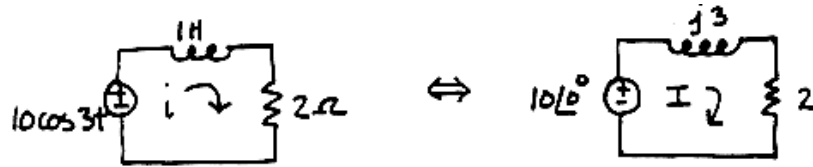

$$\text{KVL: } -10 + j3\mathbf{I} + 2\mathbf{I} = 0 \Rightarrow \mathbf{I} = \frac{10}{2+j3} = \frac{10\angle 0^\circ}{\sqrt{13}\angle 56.3^\circ} = \frac{10}{\sqrt{13}} \angle -56.3^\circ \text{ A}$$

Therefore

$$i(t) = \frac{10}{\sqrt{13}} \cos(3t - 56.3^\circ) \text{ A}$$

Ex. 10.5-1

$$\frac{10}{2.36e^{j45}} = 4.24e^{-j45} = \underline{3-j3}$$

Ex. 10.5-2

$$\frac{j32}{-3+j8} = \frac{32e^{j90}}{8.54e^{j111}} = \frac{32}{8.54} e^{j(90-111)} = \underline{3.75 e^{-j21}}$$

Ex. 10.6-1

- (a) $i = 4 \cos(\omega t - 80^\circ) = \text{Re}\{4e^{j\omega t} e^{-j80^\circ}\} \Rightarrow \mathbf{I} = 4e^{-j80^\circ} = 4\angle -80^\circ \text{ A}$
- (b) $i = 10 \cos(\omega t + 20^\circ) = \text{Re}\{10e^{j\omega t} e^{j20^\circ}\} \Rightarrow \mathbf{I} = 10e^{j20^\circ} = 10\angle 20^\circ$
- (c) $i = 8 \sin(\omega t - 20^\circ) = 8 \cos(\omega t - 110^\circ) = 8 \text{Re}\{e^{j\omega t} e^{-j110^\circ}\} \Rightarrow \mathbf{I} = 8e^{-j110^\circ} = 8\angle -110^\circ \text{ A}$

Ex. 10.6-2

- (a) $\mathbf{V} = 10\angle -140^\circ = 10e^{-j140^\circ} \text{ V} \Rightarrow v(t) = \text{Re}\{10e^{-j140^\circ} e^{j\omega t}\} = 10 \cos(\omega t - 140^\circ) \text{ V}$
- (b) $\mathbf{V} = 80 + j75 = 109.7\angle 43.2^\circ = 109.7e^{j43.2^\circ} \Rightarrow$
 $v(t) = \text{Re}\{109.7e^{j43.2^\circ} e^{j\omega t}\} = 109.7 \cos(\omega t + 43.2^\circ) \text{ V}$

Ex. 10.6-3

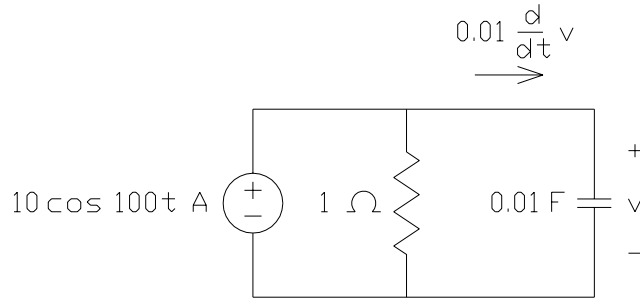

$$0.01 \frac{d}{dt} v + v = 10 \cos 100 t$$

$$(0.01)(j 100) \mathbf{V} + \mathbf{V} = 10$$

$$\mathbf{V} = \frac{10}{1+j} = 7.071 \angle -45^\circ$$

$$v = 7.071 \cos 100 t \quad \text{V}$$

Ex. 10.6-4

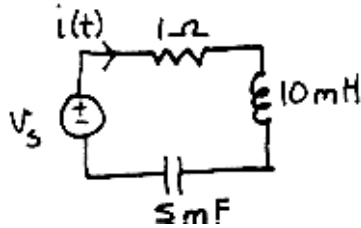

$$v_s = 40 \cos 100 t = \text{Re} \left\{ 4 e^{j 100 t} \right\}$$

$$\text{KVL: } i(t) + 10 \times 10^{-3} \frac{di(t)}{dt} + \frac{1}{5 \times 10^{-3}} \int_{-\infty}^t i(t) dt = v_s$$

Assume $i(t) = A e^{j 100 t}$ where A is complex number to be determined. Plugging into the differential equation yields

$$A e^{j 100 t} + j A e^{j 100 t} + (-j 2 A) e^{j 100 t} = 4 e^{j 100 t} \Rightarrow A = \frac{4}{1-j} = 2\sqrt{2} e^{j 45^\circ}$$

In the time domain:

$$i(t) = \text{Re} \left\{ 2\sqrt{2} e^{j 100 t} e^{j 45^\circ} \right\} = \text{Re} \left\{ 2\sqrt{2} e^{j(100 t + 45^\circ)} \right\} = 2\sqrt{2} \cos(100 t + 45^\circ) \text{ A}$$

Ex. 10.7-1

- (a) $v = Ri = 10(5 \cos 100 t) = 50 \cos 100 t$
- (b) $v = L \frac{di}{dt} = 0.01[5(-100) \sin 100 t] = -5 \sin 100 t = 5 \cos(100 t + 90^\circ) \text{ V}$
- (c) $v = \frac{1}{C} \int i dt = 10^3 \int 5 \cos 100 t dt = 50 \sin 100 t = 50 \cos(100 t - 90^\circ) \text{ V}$

Ex. 10.7-2

$$i = C \frac{dv}{dt} = 10 \times 10^{-6} [100(-500) \sin(500 t + 30^\circ)]$$

$$= -0.5 \sin(500 t + 30^\circ) = 0.5 \sin(500 t + 210^\circ) = 0.5 \cos(500 t + 120^\circ) \text{ A}$$

Ex. 10.7-3

From Figure E10.7-3 we get

$$i(t) = I_m \sin \omega t = I_m \cos(\omega t - 90^\circ) \text{ A} \Leftrightarrow \mathbf{I} = I_m \angle -90^\circ \text{ A}$$

$$v(t) = V_m \cos \omega t \Leftrightarrow \mathbf{V} = V_m \angle 0^\circ \text{ V}$$

The voltage leads the current by 90° so the element is an inductor:

$$\mathbf{Z}_{\text{eq}} = \frac{\mathbf{V}}{\mathbf{I}} = \frac{V_m \angle 0^\circ}{I_m \angle -90^\circ} = \frac{V_m}{I_m} \angle 90^\circ \Omega$$

Also

$$\mathbf{Z}_{\text{eq}} = j\omega L = \omega L \angle 90^\circ \Rightarrow \omega L = \frac{V_m}{I_m} \Rightarrow L = \frac{V_m}{\omega I_m}$$

Ex. 10.8-1

$$\mathbf{Z}_R = 8 \Omega, \mathbf{Z}_C = \frac{1}{j5 \frac{1}{12}} = \frac{2.4}{j} = \frac{j2.4}{j \times j} = -j2.4 \Omega, \mathbf{Z}_{L1} = j5(2) = j10 \Omega,$$

$$\mathbf{Z}_{L2} = j5(4) = j20 \Omega \text{ and } \mathbf{V}_S = 5 \angle -90^\circ \text{ V.}$$

Ex. 10.8-2

$$\mathbf{Z}_R = 8 \Omega, \mathbf{Z}_C = \frac{1}{j3 \frac{1}{12}} = \frac{4}{j} = \frac{j4}{j \times j} = -j4 \Omega, \mathbf{Z}_{L1} = j3(2) = j6 \Omega,$$

$$\mathbf{Z}_{L2} = j3(4) = j12 \Omega \text{ and } \mathbf{I}_S = 4 \angle 15^\circ \text{ V.}$$

Ex 10.9-1

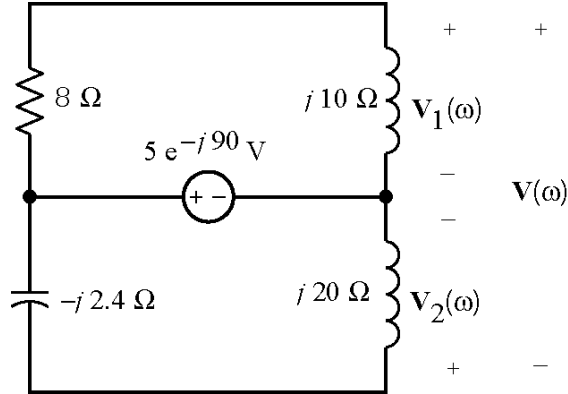

$$V_1(\omega) = \frac{j10}{8 + j10} 5e^{-j90} = 3.9e^{-j51}$$

$$V_2(\omega) = \frac{j20}{j20 - j2.4} 5e^{-j90} = 5.68e^{-j90}$$

$$V(\omega) = V_1(\omega) - V_2(\omega) = 3.9e^{-j51} - 5.68e^{-j90} \\ = 3.58e^{j47}$$

Ex 10.9-2

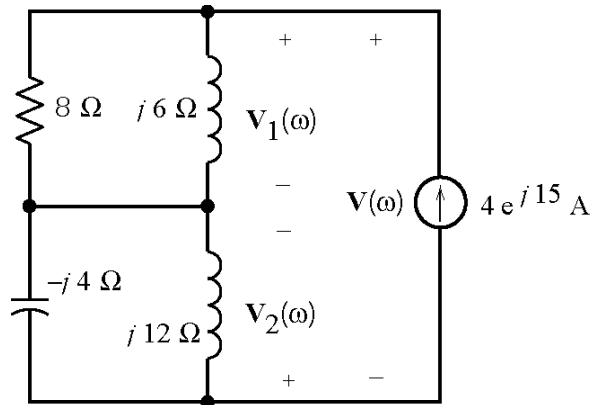

$$V_1(\omega) = \frac{8(j6)}{8 + j6} 4e^{j15} = 19.2e^{j68}$$

$$V_2(\omega) = \frac{j12(-j4)}{j12 - j4} 4e^{j15} = 24e^{-j75}$$

$$V(\omega) = V_1(\omega) + V_2(\omega) = 14.4e^{-j22}$$

Ex. 10.10-1

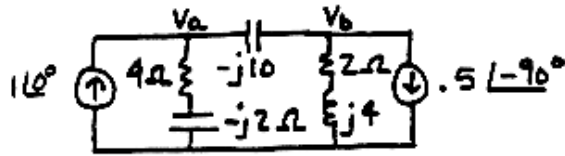

KCL at V_a :

$$\frac{V_a}{4-j2} + \frac{V_a - V_b}{-j10} = 1$$

$$(4 - j12)V_a + (-4 + j2)V_b = -20 - j40$$

KCL at V_b :

$$\frac{V_b - V_a}{-j10} + \frac{V_b}{2 + j4} + 0.5\angle -90^\circ = 0 \Rightarrow (-2 - j4)V_a + (2 - j6)V_b = 10 + j20$$

Cramer's rule yields:

$$V_a = \frac{\begin{vmatrix} (-20 - j40) & (-4 + j2) \\ (10 + j20) & (2 - j6) \end{vmatrix}}{\begin{vmatrix} (4 - j12) & (-4 + j2) \\ (-2 - j4) & (2 - j6) \end{vmatrix}} = \frac{-200 + j100}{-80 - j60} = \sqrt{5}\angle 296.5^\circ \text{ V}$$

Therefore

$$v_a(t) = \sqrt{5} \cos(100t + 296.5^\circ) = \sqrt{5} \cos(100t - 63.5^\circ) \text{ V}$$

Ex. 10.10-2

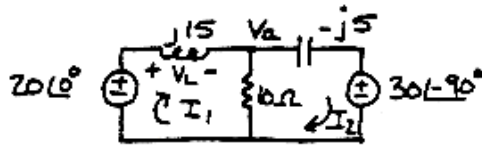

The mesh equations are:

$$j15I_1 + 10(I_1 - I_2) = 20 \Rightarrow (10 + j15)I_1 - 10I_2 = 20$$

$$-j5I_2 + 10(I_2 - I_1) = -30\angle -90^\circ \Rightarrow -10I_1 + (10 - j5)I_2 = j30$$

Cramer's rule yields:

$$I_1 = \frac{\begin{vmatrix} 20 & -10 \\ j30 & 10 - j5 \end{vmatrix}}{\begin{vmatrix} 10 + j15 & -10 \\ -10 & 10 - j5 \end{vmatrix}} = \frac{200 + j200}{75 + j100} = 2.263\angle -8.1^\circ \text{ A}$$

Next

$$V_L = (j15)I_1 = (15\angle 90^\circ)(2.263\angle -8.1^\circ) = 24\sqrt{2}\angle 82^\circ \text{ V}$$

Therefore

$$v_L(t) = 24\sqrt{2} \cos(\omega t + 82^\circ) \text{ V}$$

Ex. 10.10-3

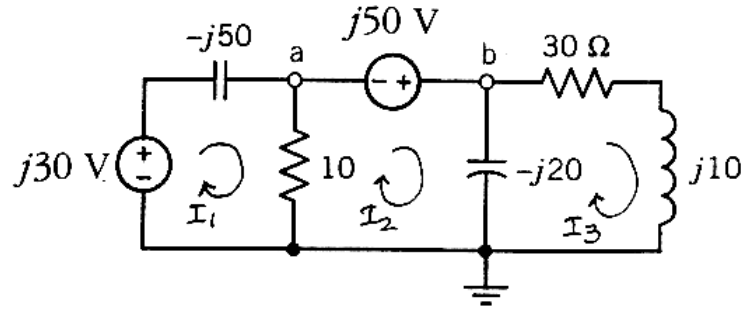

The mesh equations are:

$$(10 + j50) \mathbf{I}_1 - 10 \mathbf{I}_2 = j30$$

$$-10 \mathbf{I}_1 + (10 - j20) \mathbf{I}_2 + j20 \mathbf{I}_3 = j50$$

$$j20 \mathbf{I}_2 + (30 - j10) \mathbf{I}_3 = 0$$

Solving the mesh equations gives:

$$\mathbf{I}_1 = -0.87 - j0.09 \text{ A}, \quad \mathbf{I}_2 = -1.32 + j1.27 \text{ A}, \quad \mathbf{I}_3 = 0.5 + j1.05 \text{ A}$$

Then

$$\mathbf{V}_a = 10(\mathbf{I}_1 - \mathbf{I}_2) = 14.3 \angle -72^\circ \text{ V} \quad \text{and} \quad \mathbf{V}_b = \mathbf{V}_a + j50 = 36.6 \angle 83^\circ \text{ V}$$

Ex 10.11-1

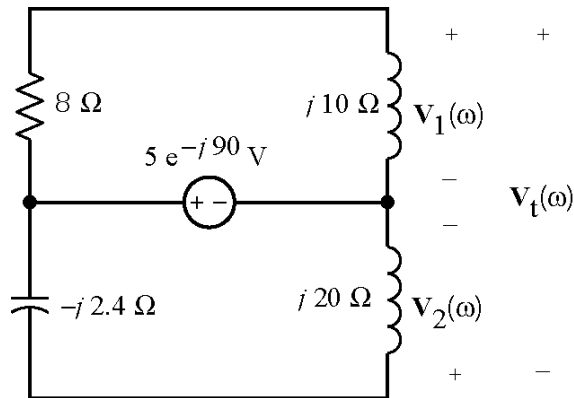

$$\mathbf{V}_1 = \frac{j10}{8 + j10} 5 e^{-j90} = 3.9 e^{-j51}$$

$$\mathbf{V}_2 = \frac{j20}{j20 - j2.4} 5 e^{-j90} = 5.68 e^{-j90}$$

$$\begin{aligned} \mathbf{V}_t &= \mathbf{V}_1 - \mathbf{V}_2 = 3.9 e^{-j51} - 5.68 e^{-j90} \\ &= 3.58 e^{j47} \end{aligned}$$

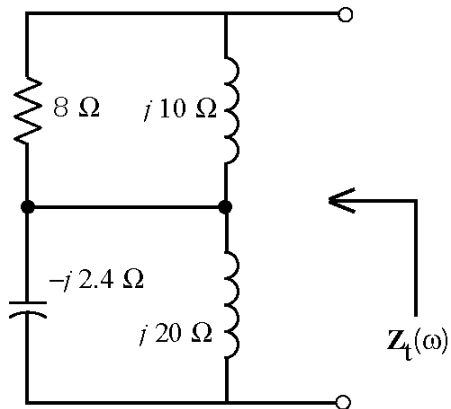

$$\mathbf{Z}_t = \frac{8(j10)}{8+j10} + \frac{-j2.4(j20)}{-j2.4+j20} = 4.9 + j1.2$$

Ex 10.11-2

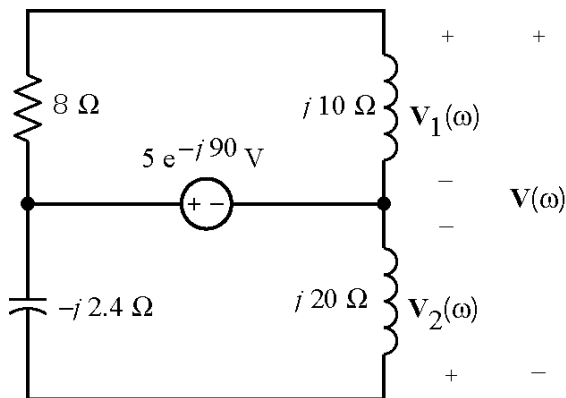

$$\mathbf{V}_1(\omega) = \frac{j10}{8+j10} 5e^{-j90} = 3.9e^{-j51}$$

$$\mathbf{V}_2(\omega) = \frac{j20}{j20-j2.4} 5e^{-j90} = 5.68e^{-j90}$$

$$\mathbf{V}(\omega) = \mathbf{V}_1(\omega) - \mathbf{V}_2(\omega) = 3.9e^{-j51} - 5.68e^{-j90} = 3.58e^{j47}$$

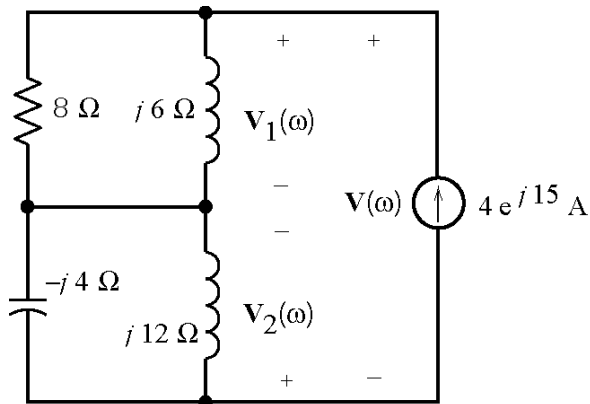

$$\mathbf{V}_1(\omega) = \frac{8(j6)}{8+j6} 4e^{j15} = 19.2e^{j68}$$

$$\mathbf{V}_2(\omega) = \frac{j12(-j4)}{j12-j4} 4e^{j15} = 24e^{-j75}$$

$$\mathbf{V}(\omega) = \mathbf{V}_1(\omega) + \mathbf{V}_2(\omega) = 14.4e^{-j22}$$

Using superposition: $v(t) = 3.58 \cos(5t + 47^\circ) + 14.4 \cos(3t - 22^\circ)$

Ex. 10.11-3

Use superposition. First, find the response to the voltage source acting alone:

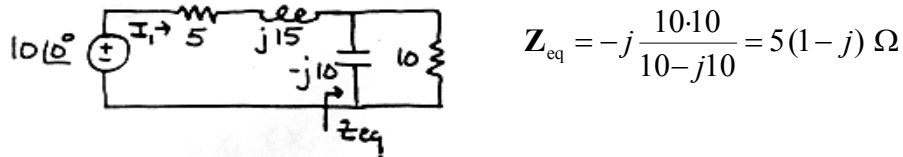

Replacing the parallel elements by the equivalent impedance. Then write a mesh equation :

$$-10 + 5 I_1 + j15 I_1 + 5(1 - j) I_1 = 0 \Rightarrow I_1 = \frac{10}{10 + j10} = 0.707 \angle -45^\circ \text{ A}$$

Therefore:

$$i_1(t) = 0.707 \cos(10t - 45^\circ) \text{ A}$$

Next, find the response to the dc current source acting alone:



Using superposition:

$$i(t) = 0.707 \cos(10t - 45^\circ) - 2 \text{ A}$$

Ex. 10.12-1

$$\omega^2 = \frac{1}{LC} = \frac{1}{(1 \times 10^{-3})(1 \times 10^{-3})} = 10^6 \Rightarrow \omega = 1000 \text{ rad/sec}$$

Ex. 10.12-2

Diagram drawn with relative magnitudes arbitrarily chosen:

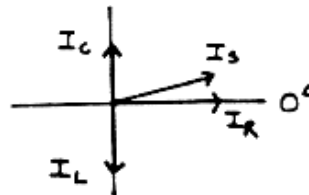

Ex. 10.12-3

Two possible phasor diagrams for currents:

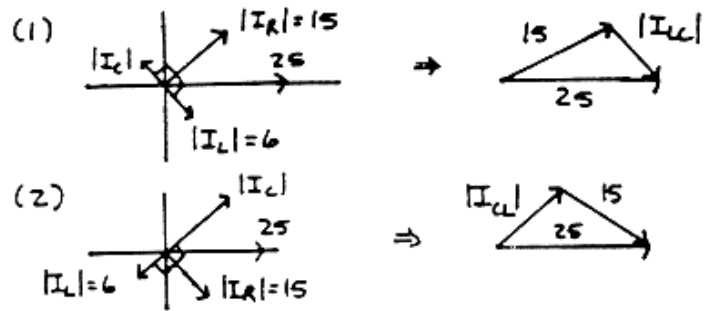

In both cases:

$$|I_{CL}| = |I_{LC}| = \sqrt{(25^2) - (15^2)} = 20 \text{ A}$$

In the first case:

$$|I_{LC}| = |I_L| - |I_C| \Rightarrow |I_C| = 6 - 20 = -14 \text{ A}$$

That isn't possible. Turning to the second case:

$$|I_{CL}| = |I_C| - |I_L| \Rightarrow |I_C| = 20 + 6 = 26 \text{ A}$$

Ex. 10.14-1

$$Z_1 = \frac{R_1 X_1 (X_1 - jR_1)}{R_1^2 + X_1^2} \quad \text{and} \quad R_1 = 1 \text{ k}\Omega, \quad X_1 = \frac{1}{\omega C_1} = \frac{1}{(1000)(10^{-6})} = 1 \text{ k}\Omega$$

$$Z_1 = \frac{(1)(1)(1-j1)}{1+1} = \frac{1}{2} - j\frac{1}{2} \text{ k}\Omega \quad \text{and} \quad Z_2 = R_2 = 1 \text{ k}\Omega$$

$$\frac{V_o}{V_s} = -\frac{Z_2}{Z_1} = \frac{-1}{\frac{1}{2} - j\frac{1}{2}} = -1-j$$

Problems

Section 10-3: Sinusoidal Sources

P10.3-1

$$\begin{aligned} \text{(a)} \quad i(t) &= 2 \cos(6t + 120^\circ) + 4 \sin(6t - 60^\circ) \\ &= 2 (\cos 6t \cos 120^\circ - \sin 6t \sin 120^\circ) + 4 (\sin 6t \cos 60^\circ - \cos 6t \sin 60^\circ) \\ &= 2.46 \cos 6t + 0.27 \sin 6t = 2.47 \cos(6t - 6.26^\circ) \end{aligned}$$

$$\begin{aligned} \text{(b)} \quad v(t) &= 5\sqrt{2} \cos 8t + 10 \sin(8t + 45^\circ) \\ &= 5\sqrt{2} \cos 8t + 10[\sin 8t \cos 45^\circ + \cos 8t \sin 45^\circ] \\ &= 10\sqrt{2} \cos 8t + 5\sqrt{2} \sin 8t \\ v(t) &= \sqrt{250} \cos(8t - 26.56^\circ) = 5\sqrt{10} \sin(8t + 63.4^\circ) \text{ V} \end{aligned}$$

P10.3-2

$$\begin{aligned} \omega &= 2\pi f = \frac{2\pi}{T} = \frac{2\pi}{1 \times 10^{-3}} = 6283 \text{ rad/sec} \\ v(t) &= V_m \sin(\omega t + \phi) = 100 \sin(6283t + \phi) \\ v(0) &= 10 = 100 \sin \phi \Rightarrow \phi = \sin^{-1}(0.1) = 6^\circ \\ v(t) &= 100 \sin(6283t + 6^\circ) \text{ V} \end{aligned}$$

P10.3-3

$$\begin{aligned} f &= \frac{\omega}{2\pi} = \frac{1200\pi}{2\pi} = 600 \text{ Hz} \\ i(2 \times 10^{-3}) &= 300 \cos(1200\pi(2 \times 10^{-3}) + 55^\circ) = 300 \cos(2.4\pi + 55^\circ) \\ 2.4\pi \times \left(\frac{180^\circ}{\pi}\right) &= 432^\circ \Rightarrow i(2 \times 10^{-3}) = 300 \cos(432^\circ + 55^\circ) = 300 \cos(127^\circ) = -180.5 \text{ mA} \end{aligned}$$

P10.3-4

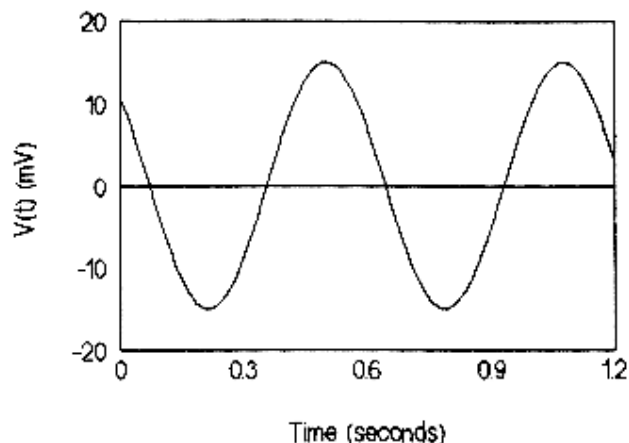

P10.3-5

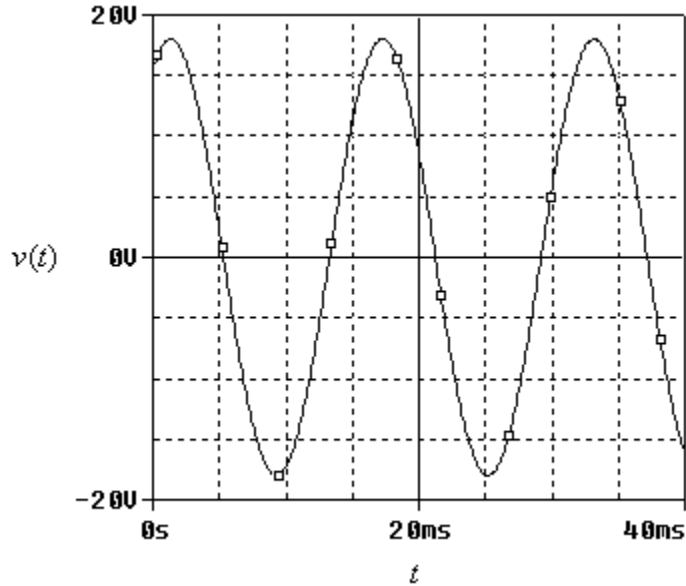

$$A = 18 \text{ V}$$

$$T = 18 - 2 = 16 \text{ ms}$$

$$\omega = \frac{2\pi}{T} = \frac{2\pi}{0.016} = 393 \text{ rad/s}$$

$$16 = 18 \cos(\theta) \Rightarrow \theta = 27^\circ$$

$$v(t) = 18 \cos(393t + 27^\circ) \text{ V}$$

P10.3-6

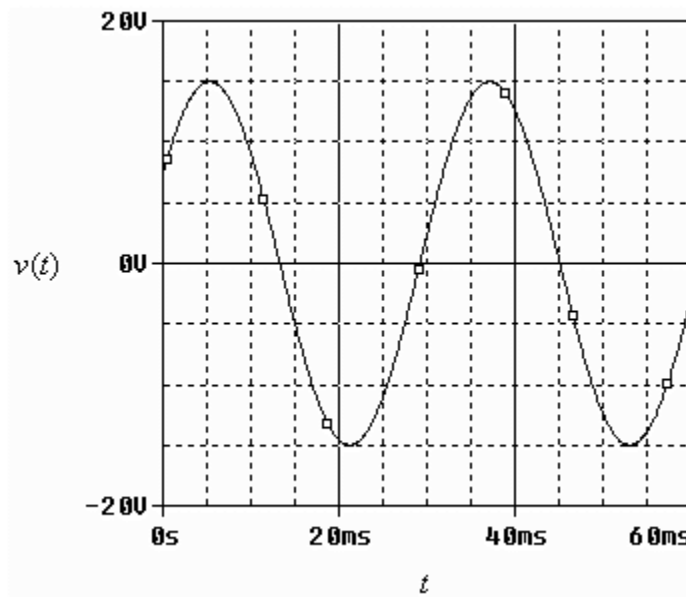

$$A = 15 \text{ V}$$

$$T = 43 - 11 = 32 \text{ ms}$$

$$\omega = \frac{2\pi}{T} = \frac{2\pi}{0.032} = 196 \text{ rad/s}$$

$$8 = 15 \cos(\theta) \Rightarrow \theta = 58^\circ$$

$$v(t) = 15 \cos(196t + 58^\circ) \text{ V}$$

Section 10-4: Steady-State Response of an RL Circuit for a Sinusoidal Forcing Function

P10.4-1

$$L \frac{di}{dt} + R_i = -v_s \Rightarrow \frac{di}{dt} + 120i = -400 \cos 300t$$

Try $i_f = A \cos 300t + B \sin 300t$ then $\frac{di_f}{dt} = -300A \sin 300t + 300B \cos 300t$. Substituting and equating coefficients gives

$$\left. \begin{aligned} -300A + 120B &= 0 \\ 300B + 120A &= -400 \end{aligned} \right\} \begin{aligned} A &= -0.46 \\ B &= -1.15 \end{aligned}$$

Then

$$i(t) = -0.46 \cos 300t - 1.15 \sin 300t = 1.24 \cos(300t - 68^\circ) \text{ A}$$

P10.4-2

$$-i_s + \frac{v}{2} + C \frac{dv}{dt} = 0 \Rightarrow \frac{dv}{dt} + 500v = 500 \cos 1000t$$

Try $v_f = A \cos 1000t + B \sin 1000t$ then $\frac{dv_f}{dt} = -1000A \sin 1000t + 1000B \cos 1000t$.

Substituting and equating coefficients gives

$$\left. \begin{aligned} -1000A + 500B &= 0 \\ 1000B + 500A &= 500 \end{aligned} \right\} \Rightarrow \begin{aligned} A &= 0.2 \\ B &= 0.4 \end{aligned}$$

Then

$$v(t) = 0.2 \cos 1000t + 0.4 \sin 1000t = 0.447 \cos(1000t - 63^\circ) \text{ V}$$

P10.4-3

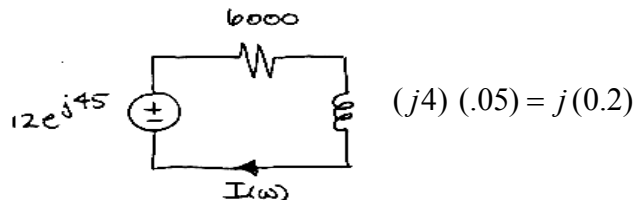

$$\mathbf{I}(\omega) = \frac{12e^{j45^\circ}}{6000 + j(0.2)} \simeq \frac{12e^{j45^\circ}}{6000} = (2 \cdot 10^{-3})e^{j45^\circ} \Rightarrow i(t) = 2 \cos(4t + 45^\circ) \text{ mA}$$

Section 10.5: Complex Exponential Forcing Function

P10.5-1

$$\frac{(5\angle 36.9^\circ)(10\angle -53.1^\circ)}{(4+j3)(6-j8)} = \frac{50\angle -16.2^\circ}{10-j5} = \frac{10\angle -16.2^\circ}{\sqrt{5}\angle -26.56^\circ} = \underline{2\sqrt{5}\angle 10.36^\circ}$$

P10.5-2

$$\begin{aligned} 5\angle +81.87^\circ \left[4-j3 + \frac{3\sqrt{2}\angle -45^\circ}{5\sqrt{2}\angle -8.13^\circ} \right] &= 5\angle +81.87^\circ \left[4-j3 + \frac{3}{5}\angle -36.87^\circ \right] \\ &= 5\angle +81.87^\circ (4.48-j3.36) = 5\angle +81.87^\circ (5.6\angle -36.87^\circ) \\ &= 28\angle +45^\circ = \underline{14\sqrt{2} + j14\sqrt{2}} \end{aligned}$$

P10.5-3

$$\frac{\mathbf{A}^* \mathbf{C}^*}{\mathbf{B}} = \frac{(3-j7)5e^{-j2.3}}{6e^{j15}} = 0.65 - j6.31$$

P10.5-4

$$(6\angle 120^\circ)(-4 + j3 + 2e^{j15}) = -12.1 - j21.3 \Rightarrow \underline{a = -12.1} \text{ and } \underline{b = -21.3}$$

P10.5-5

$$(a) \quad Ae^{j120} = -4 + j(3-b) = \sqrt{4^2 + (3-b)^2} e^{j \tan^{-1}\left(\frac{3-b}{-4}\right)}$$

$$120 = \tan^{-1}\left(\frac{3-b}{-4}\right) \Rightarrow b = 3 + 4 + \tan(120^\circ) = \underline{-3.93}$$

$$A = \sqrt{4^2 + (3-b)^2} = \sqrt{4^2 + (3 - (-3.93))^2} = \underline{8.00}$$

$$(b) \quad -4 + 8 \cos \theta + j(b + 8 \sin \theta) = 3e^{-j120} = -1.5 - j2.6$$

$$-4 + 8 \cos \theta = -1.5 \Rightarrow \theta = \cos^{-1} \frac{2.5}{8} = \underline{72^\circ}$$

$$b + 8 \sin(72^\circ) = -26 \Rightarrow \underline{b = -10.2}$$

$$(c) \quad -10 + j2a = Ae^{j60} = A \cos 60^\circ - jA \sin 60^\circ$$

$$A = \frac{-10}{\cos 60^\circ} = \underline{-20} \text{ and } a = \frac{-20 \sin 60^\circ}{2} = \underline{-8.66}$$

P 10.5-6

$$5\left(0.1\frac{d}{dt}v\right)+v=\cos 2t \Rightarrow \frac{d}{dt}v+2v=2\cos 2t$$

Replace the real excitation by a complex exponential excitation to get

$$\frac{d}{dt}v+2v=2e^{j2t}$$

Let $v_e = A e^{j2t}$ so $\frac{d}{dt}v_e = j2A e^{j2t}$ and

$$\begin{aligned}\frac{d}{dt}v_e+2v_e &= 2e^{j2t} \Rightarrow j2A e^{j2t}+2A e^{j2t}=2e^{j2t} \\ (j2+2)A e^{j2t} &= 2e^{j2t} \Rightarrow A = \frac{2}{2+j2} = \frac{1}{\sqrt{2}} \angle -45^\circ\end{aligned}$$

so
$$v_e = \left(\frac{1}{\sqrt{2}} e^{-j45^\circ}\right) e^{j2t} = \frac{1}{\sqrt{2}} e^{j(2t-45^\circ)}$$

Finally $v(t) = \text{Re}(v_e) = \frac{1}{\sqrt{2}} \cos(2t-45^\circ)$ V

P 10.5-7

$$0.45\frac{d}{dt}v+v+0.15\frac{d^2}{dt^2}v=4\cos 5t \Rightarrow \frac{d^2}{dt^2}v+3\frac{d}{dt}v+\frac{20}{3}v=\frac{80}{3}\cos 5t$$

Replace the real excitation by a complex exponential excitation to get

$$\frac{d^2}{dt^2}v+3\frac{d}{dt}v+\frac{20}{3}v=\frac{80}{3}e^{j5t}$$

Let $v_e = A e^{j5t}$ so $\frac{d}{dt}v_e = j5A e^{j5t}$, and $\frac{d^2}{dt^2}v_e = -25A e^{j5t}$

$$\begin{aligned}\frac{d^2}{dt^2}v+3\frac{d}{dt}v+\frac{20}{3}v &= \frac{80}{3}e^{j5t} \Rightarrow -25A e^{j5t}+3(j5A e^{j5t})+\frac{20}{3}(A e^{j5t}) = \frac{80}{3}e^{j5t} \\ \left(-25+j15+\frac{20}{3}\right)A e^{j5t} &= \frac{80}{3}e^{j5t} \Rightarrow A = \frac{\frac{80}{3}}{-25+j15+\frac{20}{3}} = \frac{80}{-55+j45} = 1.126 \angle -141^\circ\end{aligned}$$

so
$$v_e = \left(1.126 e^{-j141^\circ}\right) e^{j5t} = 1.126 e^{j(5t-141^\circ)}$$

Finally $v(t) = \text{Re}(v_e) = 1.126 \cos(5t-141^\circ)$ V

Section 10-6: The Phasor Concept

P10.6-1

Apply KVL

$$6i + 2 \frac{d}{dt} i - 15 \cos 4t = 0$$

or

$$2 \frac{d}{dt} i + 6i = 15 \cos 4t$$

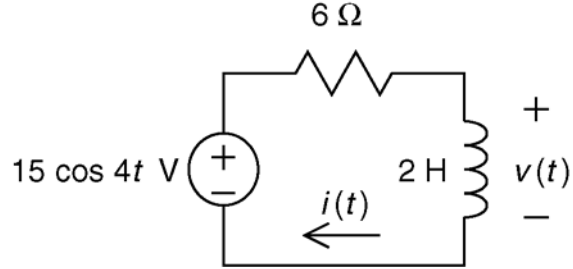

Now use $i = I_m \operatorname{Re}\{e^{j(4t+\theta)}\}$ and $15 \cos 4t = 15 \operatorname{Re}\{e^{4t}\}$ to write

$$2 \frac{d}{dt} (I_m \operatorname{Re}\{e^{j(4t+\theta)}\}) + 6 (I_m \operatorname{Re}\{e^{j(4t+\theta)}\}) = 15 \operatorname{Re}\{e^{4t}\}$$

$$\operatorname{Re}\left\{2 \frac{d}{dt} (I_m e^{j4t} e^{j\theta}) + 6 (I_m e^{j4t} e^{j\theta})\right\} = \operatorname{Re}\{15 e^{4t}\}$$

$$\operatorname{Re}\left\{2 (j4 I_m e^{j4t} e^{j\theta}) + 6 (I_m e^{j4t} e^{j\theta})\right\} = \operatorname{Re}\{15 e^{4t}\}$$

$$j8 (I_m e^{j\theta}) + 6 (I_m e^{j\theta}) = 15$$

$$I_m e^{j\theta} = \frac{15}{6 + j8} = \frac{15}{10 \angle 53^\circ} = 1.5 \angle -53^\circ$$

$$i(t) = 1.5 \cos(4t - 53^\circ) \text{ A}$$

Finally

$$\begin{aligned} v(t) &= 2 \frac{d}{dt} i(t) = 2 \frac{d}{dt} (1.5 \cos(4t - 53^\circ)) = 3(-4 \sin(4t - 53^\circ)) \\ &= -12(\cos(4t - 143^\circ)) \\ &= 12 \cos(4t + 37^\circ) \text{ V} \end{aligned}$$

P10.6-2

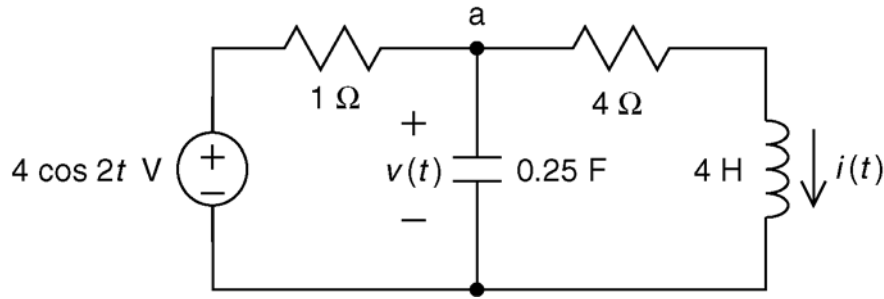

Apply KCL at node a:

$$\frac{v - 4 \cos 2t}{1} + 0.25 \frac{d}{dt} v + i = 0$$

Apply KVL to the right mesh:

$$4i + 4 \frac{d}{dt} i - v = 0 \Rightarrow v = 4i + 4 \frac{d}{dt} i$$

After some algebra:

$$\frac{d^2}{dt^2} i + 5 \frac{d}{dt} i + 5i = 4 \cos 2t$$

Now use $i = I_m \operatorname{Re}\{e^{j(2t+\theta)}\}$ and $4 \cos 2t = 4 \operatorname{Re}\{e^{j2t}\}$ to write

$$\frac{d^2}{dt^2} [I_m \operatorname{Re}\{e^{j(2t+\theta)}\}] + 5 \frac{d}{dt} [I_m \operatorname{Re}\{e^{j(2t+\theta)}\}] + 5 [I_m \operatorname{Re}\{e^{j(2t+\theta)}\}] = 4 \operatorname{Re}\{e^{j2t}\}$$

$$\operatorname{Re} \left\{ \frac{d^2}{dt^2} [I_m e^{j(2t+\theta)}] + 5 \frac{d}{dt} [I_m e^{j(2t+\theta)}] + 5 [I_m e^{j(2t+\theta)}] \right\} = \operatorname{Re}\{4 e^{j2t}\}$$

$$\operatorname{Re} \left\{ -4 e^{j\theta} I_m e^{j2t} + 5 (j2 e^{j\theta} I_m e^{j2t}) + 5 e^{j\theta} I_m e^{j2t} \right\} = \operatorname{Re}\{4 e^{j2t}\}$$

$$-4 e^{j\theta} I_m + 5 (j2 e^{j\theta} I_m) + 5 e^{j\theta} I_m = 4$$

$$I_m e^{j\theta} = \frac{4}{-4 + 5(j2) + 5} = \frac{4}{1 + j10} = \frac{4}{10.05 \angle 84} = 0.398 \angle -84^\circ$$

$$i(t) = 0.398 \cos(2t - 85^\circ) \text{ A}$$

P10.6-3

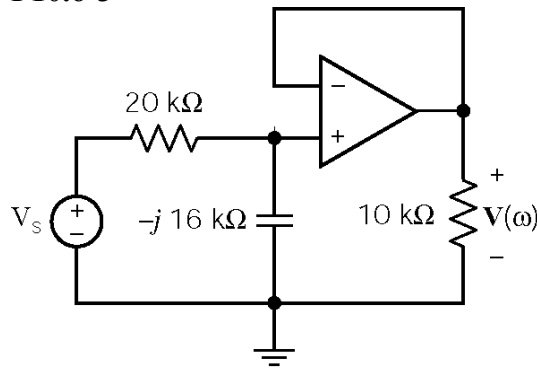

$$\mathbf{V}_s = 2 \angle -90^\circ \text{ V}$$

$$\mathbf{Z}_R = R; \quad \mathbf{Z}_C = \frac{-j}{\omega C} = \frac{-j}{(500)(0.125 \times 10^{-6})} = -j16000 \Omega$$

$$\mathbf{V}(\omega) = \left(\frac{-j16000}{20000 - j16000} \right) (2 \angle -90^\circ) = \frac{(16000 \angle -90^\circ)(2 \angle -90^\circ)}{25612 \angle -39^\circ} = 1.25 \angle -141^\circ \text{ V}$$

therefore

$$v(t) = 1.25 \cos(500t - 141^\circ) \text{ V}$$

Section 10-7: Phasor Relationships for R, L, and C Elements

P10.7-1

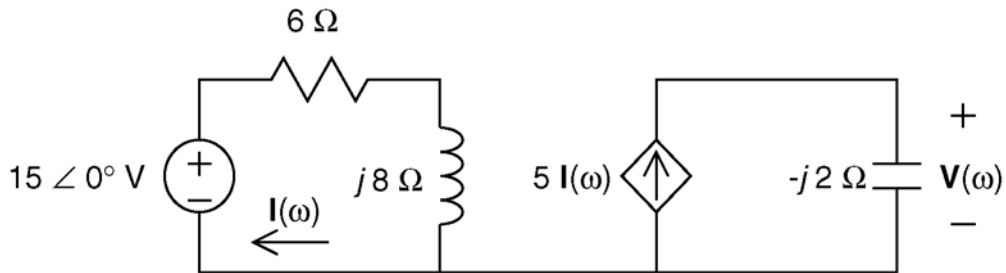

P10.7-2

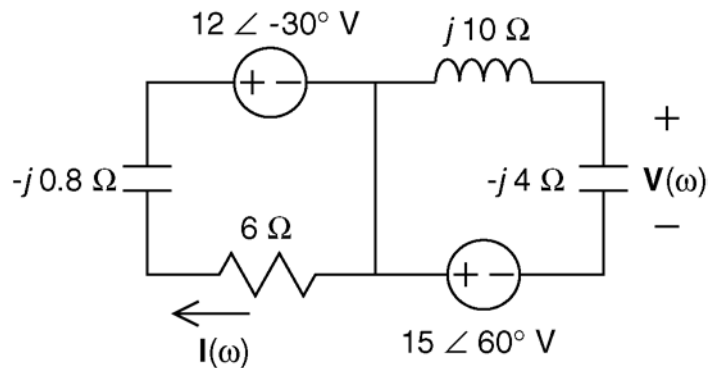

P10.7.3

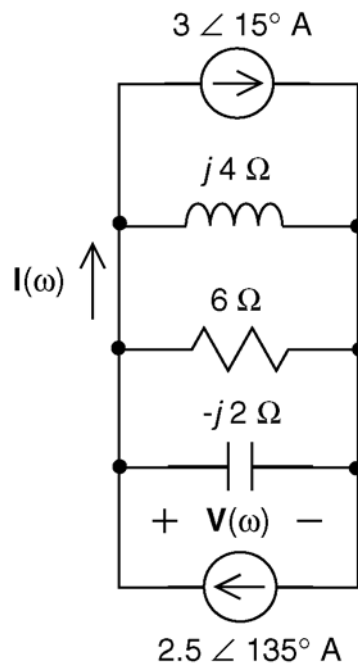

P10.7-4

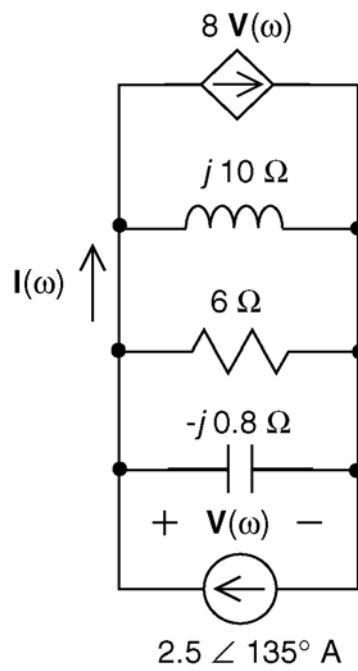

P10.7-5

(a) $v = 15 \cos(400t + 30^\circ) \text{ V}$

$i = 3 \sin(400t + 30^\circ) = 3 \cos(400t - 60^\circ) \text{ V}$

 v leads i by $90^\circ \Rightarrow$ element is an inductor

$$|Z_L| = \frac{v_{\text{peak}}}{i_{\text{peak}}} = \frac{15}{3} = 5 = \omega L = 400L \Rightarrow \underline{L = 0.0125 \text{ H} = 12.5 \text{ mH}}$$

(b) i leads v by $90^\circ \Rightarrow$ the element is a capacitor

$$|Z_c| = \frac{v_{\text{peak}}}{i_{\text{peak}}} = \frac{8}{2} = 4 = \frac{1}{\omega C} = \frac{1}{900C} \Rightarrow \underline{C = 277.77 \mu\text{F}}$$

(c) $v = 20 \cos(250t + 60^\circ) \text{ V}$

$i = 5 \sin(250t + 150^\circ) = 5 \cos(250t + 60^\circ) \text{ A}$

Since v & i are in phase \Rightarrow element is a resistor

$$\therefore R = \frac{v_{\text{peak}}}{i_{\text{peak}}} = \frac{20}{5} = \underline{4 \Omega}$$

P10.7-6

$$\mathbf{V}_1 = 150 \cos(-30^\circ) + j150 \sin(-30^\circ) = 130 - j75 \text{ V}$$

$$\mathbf{V}_2 = 200 \cos 60^\circ + j200 \sin 60^\circ = 100 + j173 \text{ V}$$

$$\mathbf{V} = \mathbf{V}_1 + \mathbf{V}_2 = 230 + j98 = 250 \angle 23.1^\circ \text{ V}$$

$$\text{Thus } \underline{v(t) = v_1(t) + v_2(t) = 250 \cos(377t + 23.1^\circ) \text{ V}}$$

Section 10-8: Impedance and Admittance

P10.8-1

$$\omega = 2\pi f = 2\pi(10 \times 10^3) = 62830 \text{ rad/sec}$$

$$\mathbf{Z}_R = R = 36 \Omega \Leftrightarrow \mathbf{Y}_R = \frac{1}{\mathbf{Z}_R} = \frac{1}{36} = 0.0278 \text{ S}$$

$$\mathbf{Z}_L = j\omega L = j(62830)(160 \times 10^{-6}) = j10 \Omega \Leftrightarrow \mathbf{Y}_L = \frac{1}{\mathbf{Z}_L} = -0.1j \text{ S}$$

$$\mathbf{Z}_C = \frac{-j}{\omega C} = \frac{-j}{(62830)(1 \times 10^{-6})} = -j16 \Omega \Leftrightarrow \mathbf{Y}_C = \frac{1}{\mathbf{Z}_C} = 0.0625j \text{ S}$$

$$\mathbf{Y}_{\text{eq}} = \mathbf{Y}_R + \mathbf{Y}_L + \mathbf{Y}_C = 0.0278 - j0.00375 = 0.027 \angle 9^\circ \text{ S}$$

$$\mathbf{Z}_{\text{eq}} = \frac{1}{\mathbf{Y}_{\text{eq}}} = 36.5 \angle 9^\circ = \underline{36 - j5.86 \Omega}$$

P10.8-2

$$\mathbf{Z} = \frac{\mathbf{V}}{-\mathbf{I}} = \frac{-10 \angle 40^\circ}{2 \times 10^{-3} \angle 195^\circ} = -5000 \angle -155^\circ \Omega = 4532 + 2113j = R + j\omega L$$

$$\text{so } \underline{R=4532 \Omega} \text{ and } \underline{L = \frac{2113}{\omega} = \frac{2113}{2 \times 10^6} = 1.06 \text{ mH}}$$

P10.8-3

$$\begin{aligned} \mathbf{Z}(\omega) &= \frac{-\frac{j}{\omega C}(R + j\omega L)}{-\frac{j}{\omega C} + (R + j\omega L)} = \frac{\frac{L}{C} - j\frac{R}{\omega C}}{R + j\left(\omega L - \frac{1}{\omega C}\right)} \\ &= \frac{\left(\frac{L}{C} - j\frac{R}{\omega C}\right)\left(R - j\left(\omega L - \frac{1}{\omega C}\right)\right)}{R^2 + \left(\omega L - \frac{1}{\omega C}\right)^2} \\ &= \frac{\frac{RL}{C} - \frac{R}{\omega C}\left(\omega L - \frac{1}{\omega C}\right) - j\left(\frac{R^2}{\omega C} + \frac{L}{C}\left(\omega L - \frac{1}{\omega C}\right)\right)}{R^2 + \left(\omega L - \frac{1}{\omega C}\right)^2} \end{aligned}$$

$\mathbf{Z}(\omega)$ will be purely resistive when

$$\frac{R^2}{\omega C} + \frac{L}{C} \left(\omega L - \frac{1}{\omega C} \right) = 0 \Rightarrow \omega^2 = \frac{1}{CL} - \left(\frac{R}{L} \right)^2$$

when $R=6 \Omega$, $C = 22 \mu\text{F}$, and $L = 27 \text{ mH}$, then $\omega = 1278 \text{ rad/s}$.

P10.8-4

$$\mathbf{Z} = \mathbf{Z}_L + \frac{\mathbf{Z}_c R}{R + \mathbf{Z}_c} = j\omega L + \frac{\frac{R}{j\omega C}}{R + \frac{1}{j\omega C}} = \frac{R + j(\omega L - \omega R^2 C + \omega^3 R^2 L C^2)}{1 + (\omega R C)^2}$$

Set real part equal to 100Ω to get C

$$\frac{R}{1 + (\omega R C)^2} = 100 \Rightarrow \underline{C = 0.158 \mu\text{F}}$$

Set imaginary part of numerator equal to 0 to get L ($\omega = 2\pi f = 6283 \text{ rad/sec}$)

$$L - R^2 C + \omega^2 R^2 L C^2 = 0 \Rightarrow \underline{L = 0.1587 \text{ H}}$$

P10.8-5

$$\mathbf{Z}_L = j\omega L = j(6.28 \times 10^6)(47 \times 10^{-6}) = j 300 \Omega$$

$$\mathbf{Z}_{\text{eq}} = \mathbf{Z}_c \parallel (\mathbf{Z}_R + \mathbf{Z}_L) = \frac{\left(\frac{1}{j\omega C} \right) (300 + j300)}{\frac{1}{j\omega C} + 300 + j300} = 590.7 \Omega$$

$$590.7 = \frac{300 + 300j}{1 + 300j\omega C - 300\omega C} \Rightarrow 590.7 - (590.7)(300\omega C) + j(590.7)(300\omega C) = 300 + j300$$

Equating imaginary terms ($\omega = 2\pi f = 6.28 \times 10^6 \text{ rad/sec}$)

$$(590.7)(300\omega C) = 300 \Rightarrow \underline{C = 0.27 \text{ nF}}$$

Section 10-9: Kirchhoff's Laws Using Phasors

P10.9-1

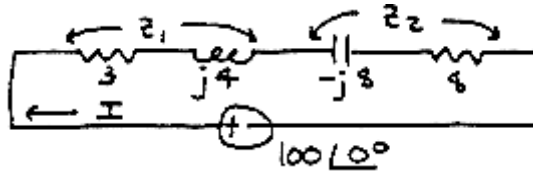

(a) $\underline{Z}_1 = 3 + j4 = 5\angle 53.1^\circ\ \Omega$ and $\underline{Z}_2 = 8 - j8 = 8\sqrt{2}\angle -45^\circ\ \Omega$

(b) Total impedance = $\underline{Z}_1 + \underline{Z}_2 = 3 + j4 + 8 - j8 = 11 - j4 = 11.7\angle -20.0^\circ\ \Omega$

(c) $\underline{I} = \frac{100\angle 0^\circ}{\underline{Z}_1 + \underline{Z}_2} = \frac{100}{11.7\angle -20^\circ} = \frac{100}{11.7}\angle 20.0^\circ \Rightarrow \underline{i(t)} = 8.55 \cos(1250t + 20.0^\circ)\ \text{A}$

P10.9-2

$$\begin{aligned} V_1(\omega) &= V_s(\omega) - V_2(\omega) = 7.68\angle 47^\circ - 1.59\angle 125^\circ \\ &= (5.23 + j5.62) - (-0.91 + j1.30) \\ &= (5.23 + 0.91) + j(5.62 - 1.30) \\ &= 6.14 + j4.32 \\ &= 7.51\angle 35^\circ \end{aligned}$$

$$v_1(t) = 7.51 \cos(2t + 35^\circ)\ \text{V}$$

P10.9-3

$$\begin{aligned} \underline{I} &= \underline{I}_1 + \underline{I}_2 = 0.744\angle -118^\circ + 0.5405\angle 100^\circ = (-0.349 - j0.657) + (-0.094 + j0.532) \\ &= (-0.349 - 0.094) + j(-0.657 + 0.532) \\ &= -0.443 - j0.125 \\ &= 0.460\angle 196^\circ \end{aligned}$$

$$i(t) = 460 \cos(2t + 196^\circ)\ \text{mA}$$

P10.9-4

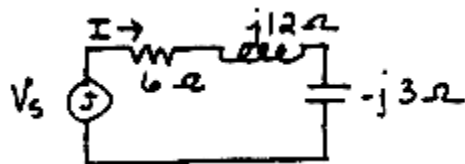

$$\underline{V}_s = 2\angle 30^\circ\ \text{V} \quad \text{and} \quad \underline{I} = \frac{2\angle 30^\circ}{6 + j12 + 3/j} = 0.185\angle -26.3^\circ\ \text{A}$$

$$\underline{i(t)} = 0.185 \cos(4t - 26.3^\circ)\ \text{A}$$

P10.9-5

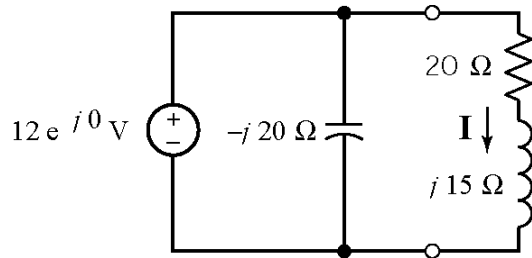

$$j15 = j(2\pi \cdot 796)(3 \cdot 10^{-3})$$

$$\mathbf{I} = \frac{12}{20 + j15} = 0.48 \angle -37^\circ \text{ A}$$

$$i(t) = 0.48 \cos(2\pi \cdot 796t - 37^\circ) \text{ A}$$

P10.9-6

$$\mathbf{Z}_1 = R = 8 \Omega, \quad \mathbf{Z}_2 = j3L, \quad \mathbf{I} = B \angle -51.87^\circ \text{ and } \mathbf{I}_s = 2 \angle -15^\circ \text{ A}$$

$$\frac{\mathbf{I}}{\mathbf{I}_s} = \frac{B \angle -51.87^\circ}{2 \angle -15^\circ} = \frac{\mathbf{Z}_1}{\mathbf{Z}_1 + \mathbf{Z}_2} = \frac{8}{8 + j3L} = \frac{8 \angle 0^\circ}{\sqrt{8^2 + (3L)^2} \angle \tan^{-1}\left(\frac{3L}{8}\right)}$$

Equate the magnitudes and the angle.

$$\text{angles: } +36.87 = +\tan^{-1}\left(\frac{3L}{8}\right) \Rightarrow L = 2 \text{ H}$$

$$\text{magnitudes: } \frac{8}{\sqrt{64 + 9L^2}} = \frac{B}{2} \Rightarrow B = 1.6$$

P10.9-7

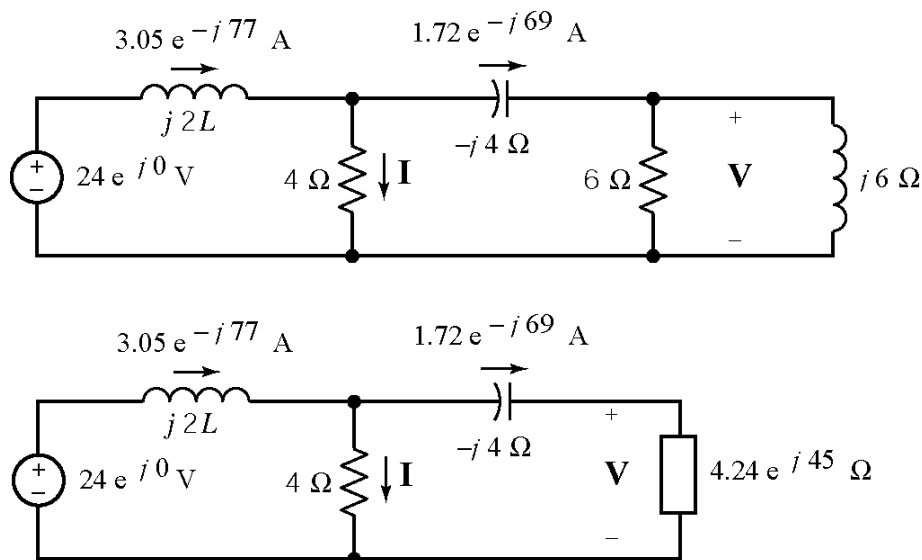

The voltage \mathbf{V} can be calculated using Ohm's Law.

$$\mathbf{V} = (1.72 \angle -69^\circ) (4.24 \angle 45^\circ) = 7.29 \angle -24^\circ \text{ V}$$

The current \mathbf{I} can be calculated using KCL.

$$\mathbf{I} = (3.05 \angle -77^\circ) - (1.72 \angle -69^\circ) = 1.34 \angle -87^\circ \text{ A}$$

Using KVL to calculate the voltage across the inductor and then Ohm's Law gives:

$$j2L = \frac{24 - 4(1.34 \angle -87^\circ)}{3.05 \angle -77^\circ} \Rightarrow L = 4 \text{ H}$$

P10.9-8

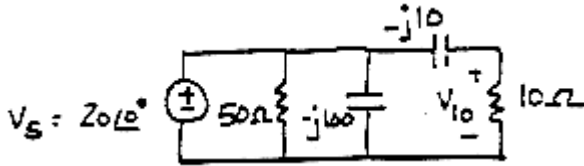

$$\begin{aligned} \mathbf{V}_{10} &= \mathbf{V}_s \left(\frac{10}{10 - j10} \right) = 20 \angle 0^\circ \left(\frac{10}{10\sqrt{2} \angle -45^\circ} \right) \\ &= 0\sqrt{2} \angle 45^\circ \end{aligned}$$

$$v_{10}(t) = 10\sqrt{2} \cos(100t + 45^\circ) \text{ V}$$

P10.9-9

(a)

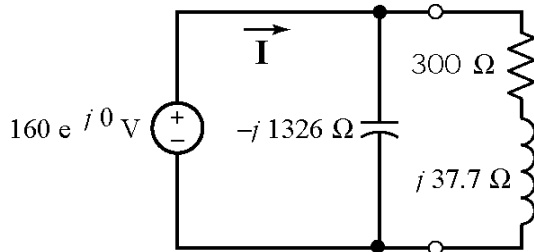

$$\begin{aligned} \mathbf{I} &= \frac{160 \angle 0^\circ}{\frac{(-j1326)(300 + j37.7)}{-j1326 + 300 + j37.7}} = \frac{160 \angle 0^\circ}{303 \angle -5.9^\circ} \\ &= 0.53 \angle 5.9^\circ \text{ A} \end{aligned}$$

$$\underline{i(t) = 0.53 \cos(120\pi t + 5.9^\circ) \text{ A}}$$

(b)

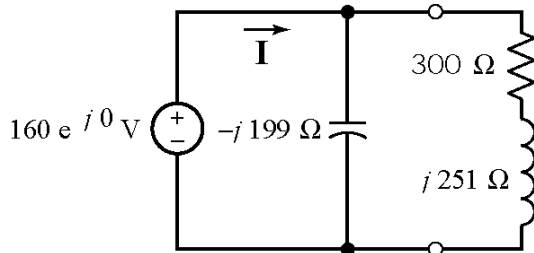

$$\begin{aligned} \mathbf{I} &= \frac{160 \angle 0^\circ}{\frac{(-j199)(300 + j251)}{-j199 + 300 + j251}} = \frac{160 \angle 0^\circ}{256 \angle -59.9^\circ} \\ &= 0.625 \angle 59.9^\circ \text{ A} \end{aligned}$$

$$\underline{i(t) = 0.625 \cos(800\pi t + 59.9^\circ) \text{ A}}$$

Section 10-10: Node Voltage and Mesh Current Analysis Using Phasors

P10.10-1

Draw frequency domain circuit and write node equations:

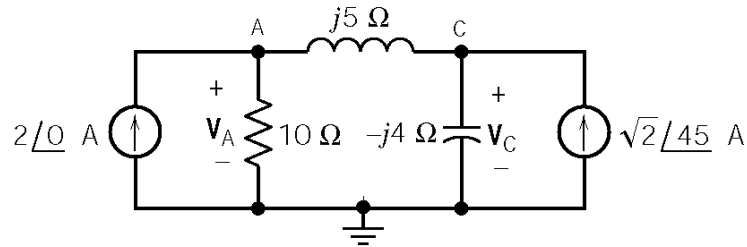

$$\text{KCL at A} \quad -2 + \frac{V_A}{10} + \frac{V_A - V_C}{j5} = 0 \Rightarrow (2 + j)V_A - 2V_C = j20$$

$$\text{KCL at C:} \quad \frac{V_C - V_A}{j5} + \frac{V_C}{-j4} - (1 + j) = 0 \Rightarrow 4V_A + V_C = 20 - j20$$

Solve using Cramers rule:

$$V_C = \frac{\begin{vmatrix} (2+j) & j20 \\ 4 & 20-j20 \end{vmatrix}}{\begin{vmatrix} (2+j) & -2 \\ 4 & 1 \end{vmatrix}} = \frac{60 - j100}{10 + j} = \frac{116.6 \angle -59^\circ}{\sqrt{101} \angle 5.7^\circ} = \underline{11.6 \angle -64.7^\circ \text{ V}}$$

P10.10-2

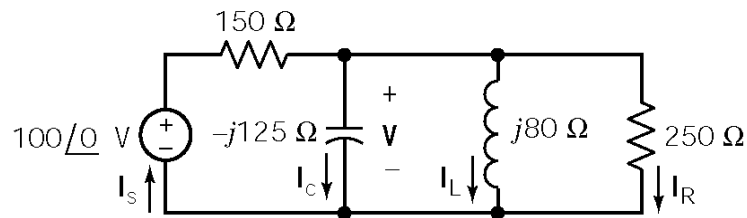

$$\text{KCL:} \quad \frac{(V-100)}{150} + \frac{V}{-j125} + \frac{V}{j80} + \frac{V}{250} = 0 \Rightarrow V = 57.6 \angle 22.9^\circ \text{ V}$$

$$I_S = \frac{100 - V}{150} = 0.667 - 0.384 \angle 22.9^\circ = \underline{0.347 \angle -25.5^\circ \text{ A}}$$

$$I_C = \frac{V}{125 \angle -90^\circ} = \underline{0.461 \angle 112.9^\circ \text{ A}}$$

$$\mathbf{I}_L = \frac{\mathbf{V}}{80 \angle 90^\circ} = \underline{0.720 \angle -67.1^\circ \text{ A}}$$

$$\mathbf{I}_R = \frac{\mathbf{V}}{250} = \underline{0.230 \angle 22.9^\circ \text{ A}}$$

P10.10-3

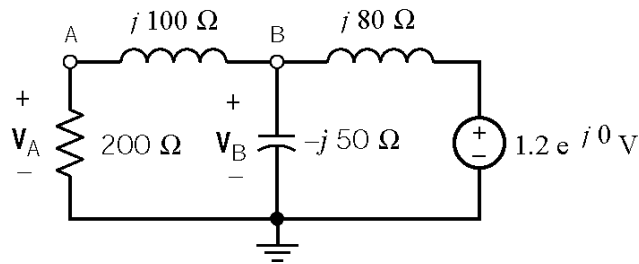

KCL at node A:

$$\frac{\mathbf{V}_a}{200} + \frac{\mathbf{V}_a - \mathbf{V}_b}{j100} = 0 \quad (1)$$

KCL at node B:

$$\begin{aligned} \frac{\mathbf{V}_b - \mathbf{V}_a}{j100} + \frac{\mathbf{V}_b}{-j50} + \frac{\mathbf{V}_b - 1.2}{j80} &= 0 \\ \Rightarrow \mathbf{V}_a &= \frac{1}{4} \mathbf{V}_b - \frac{3}{2} \quad (2) \end{aligned}$$

Substitute Eqn (2) into Eqn (1) to get

$$\mathbf{V}_b = 2.21 \angle -144^\circ \text{ V}$$

Then Eqn (2) gives

$$\mathbf{V}_a = (0.55 \angle -144^\circ) - 1.5 = 1.97 \angle -171^\circ \text{ V}$$

Finally

$$v_a(t) = 1.97 \cos(4000t - 171^\circ) \text{ V and } v_b(t) = 2.21 \cos(4000t - 144^\circ) \text{ V}$$

P10.10-4

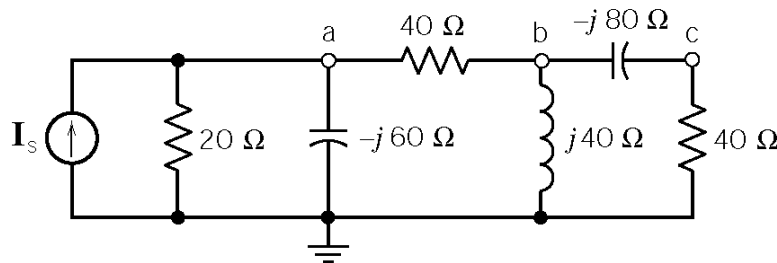

$$\omega = 10^4 \text{ rad/s}$$

$$\mathbf{I}_s = 20 \angle 53^\circ \text{ A}$$

The node equations are:

$$\text{KCL at a: } \left(\frac{1}{20} + \frac{1}{40} + \frac{j}{60} \right) \mathbf{V}_a + \left(-\frac{1}{40} \right) \mathbf{V}_b = 20 \angle 53.13^\circ$$

$$\text{KCL at b: } \left(-\frac{1}{40} \right) \mathbf{V}_a + \left(\frac{1}{40} - \frac{j}{40} + \frac{j}{80} \right) \mathbf{V}_b - \frac{j}{80} \mathbf{V}_c = 0$$

$$\text{KCL at c: } \frac{-j}{80} \mathbf{V}_b + \left(\frac{1}{40} + \frac{j}{80} \right) \mathbf{V}_c = 0$$

Solving these equations yields

$$\mathbf{V}_a = \sqrt{2} \cdot 240 \angle 45^\circ \text{ V} \Rightarrow v_a(t) = 339.4 \cos(\omega t + 45^\circ) \text{ V}$$

P10.10-5

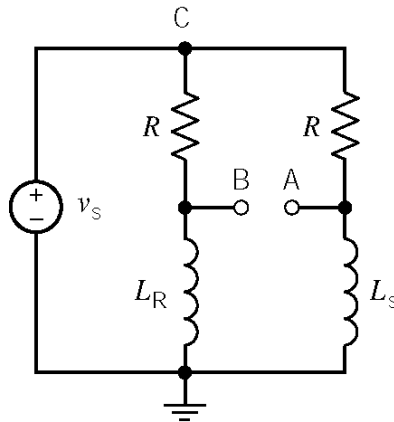

$$v_s = \sin(2\pi \cdot 400t) \text{ V}$$

$$R = 100 \Omega$$

$$L_R = 40 \text{ mH}$$

$$L_S = \begin{cases} 40 \text{ mH} & \text{door opened} \\ 60 \text{ mH} & \text{door closed} \end{cases}$$

With the door open $|\mathbf{V}_A - \mathbf{V}_B| = 0$ since the bridge circuit is balanced.

With the door closed $\mathbf{Z}_{L_R} = j(800\pi)(0.04) = j100.5 \Omega$ and $\mathbf{Z}_{L_S} = j(800\pi)(0.06) = j150.8 \Omega$.

The node equations are:

$$\text{KCL at node B: } \frac{\mathbf{V}_B - \mathbf{V}_C}{R} + \frac{\mathbf{V}_B}{\mathbf{Z}_{L_R}} = 0 \Rightarrow \mathbf{V}_B = \frac{j100.5}{j100.5 + 100} \mathbf{V}_C$$

$$\text{KCL at node A: } \frac{\mathbf{V}_A - \mathbf{V}_C}{R} + \frac{\mathbf{V}_A}{\mathbf{Z}_{L_S}} = 0$$

Since $V_C = |V_s| = 1 \text{ V}$

$$V_B = 0.709 \angle 44.86^\circ \text{ V and } V_A = 0.833 \angle 33.55^\circ \text{ V}$$

Therefore

$$\begin{aligned} V_A - V_B &= 0.833 \angle 33.55^\circ - 0.709 \angle 44.86^\circ = (0.694 + j0.460) - (0.503 + j0.500) = 0.191 - j0.040 \\ &= 0.195 \angle -11.83^\circ \text{ V} \end{aligned}$$

P10.10-6

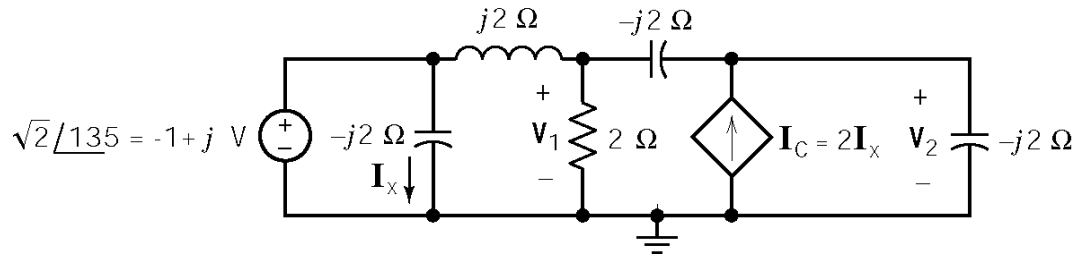

The node equations are:

$$\frac{V_1 - (-1 + j)}{j2} + \frac{V_1}{2} + \frac{V_1 - V_2}{-j2} = 0$$

$$\frac{V_2 - V_1}{-j2} + \frac{V_2}{-j2} - I_C = 0$$

Also, expressing the controlling signal of the dependent source in terms of the node voltages yields

$$I_x = \frac{-1 + j}{-2j} \Rightarrow I_C = 2I_x = 2 \left[\frac{-1 + j}{-2j} \right] = -1 - j \text{ A}$$

Solving these equations yields

$$V_2 = \frac{-3 - j}{1 + j2} = \sqrt{2} \angle -135^\circ \text{ V} \Rightarrow v(t) = v_2(t) = \sqrt{2} \cos(40t - 135^\circ) \text{ V}$$

P10.10-7

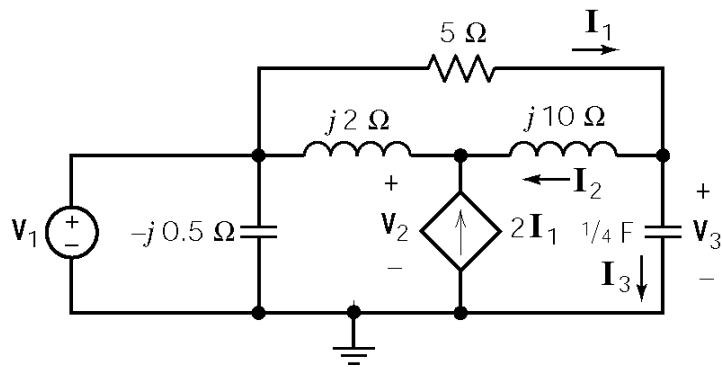

$$\begin{aligned} V_2 &= 0.7571 \angle 66.7^\circ \text{ V} \\ V_3 &= 0.6064 \angle -69.8^\circ \text{ V} \end{aligned}$$

$$\left. \begin{aligned} I_1 &= I_2 + I_3 \\ I_2 &= \frac{V_3 - V_2}{j10} \\ I_3 &= \frac{V_3}{-j2} \end{aligned} \right\} \text{yields } \begin{cases} I_3 = 0.3032 \angle 20.2^\circ \text{ A} \\ I_2 = 0.1267 \angle -184^\circ \text{ A} \\ I_1 = 0.195 \angle 36^\circ \text{ A} \end{cases}$$

therefore

$$i_1(t) = 0.195 \cos(2t + 36^\circ) \text{ A}$$

P10.10-8

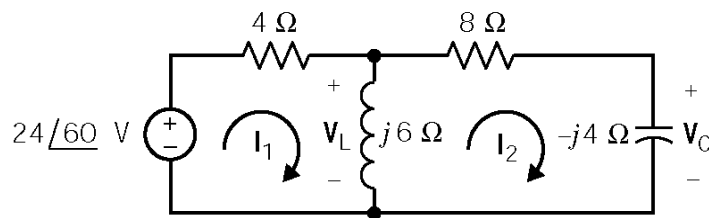

The mesh equations are

$$\begin{aligned} (4 + j6)I_1 - j6I_2 &= 12 + j12\sqrt{3} \\ -j6I_1 + (8 + j2)I_2 &= 0 \end{aligned}$$

Using Cramer's rule yields

$$I_1 = \frac{(12 + j12\sqrt{3})(8 + j2)}{(4 + j6)(8 + j2) - (-j6)(-j6)} = 2.5 \angle 29^\circ = 2.2 + j1.2 \text{ A}$$

Then

$$I_2 = \frac{j6}{8 + j2}(2.5 \angle 29^\circ) = \frac{6 \angle 90^\circ}{\sqrt{68} \angle 14^\circ}(2.5 \angle 29^\circ) = 1.82 \angle 105^\circ \text{ A}$$

and

$$V_L = j6(I_1 - I_2) = (6 \angle 90^\circ)(2.5 \angle 29^\circ - 1.82 \angle 105^\circ) = (6 \angle 90^\circ)(2.71 \angle -11.3^\circ) = 16.3 \angle 78.7^\circ \text{ V}$$

Finally

$$V_C = -j4I_2 = (4 \angle -90^\circ)(1.82 \angle 105^\circ) = 7.28 \angle 15^\circ \text{ V}$$

P10.10-9

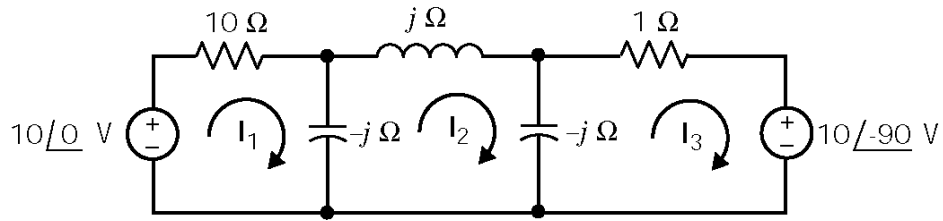

The mesh equations are:

$$\begin{aligned} (10-j) \mathbf{I}_1 + (j) \mathbf{I}_2 + 0 \mathbf{I}_3 &= 10 \\ j \mathbf{I}_1 - j \mathbf{I}_2 + j \mathbf{I}_3 &= 0 \\ 0 \mathbf{I}_1 + j \mathbf{I}_2 + (1-j) \mathbf{I}_3 &= j10 \end{aligned}$$

Solving these mesh equations using Cramer's rule yields:

$$\mathbf{I}_2 = \frac{\begin{vmatrix} (10-j) & 10 & 0 \\ j & 0 & j \\ 0 & j10 & (1-j) \end{vmatrix}}{\begin{vmatrix} (10-j) & j & 0 \\ j & -j & j \\ 0 & j & (1-j) \end{vmatrix}} = \frac{90 - j20}{-11j} = 8.38 \angle 77.5^\circ \text{ A} \Rightarrow i(t) = 8.38 \cos(10^3 t + 77.5^\circ) \text{ A}$$

(checked using LNAPAC on 7/3/03)

P10.10-10

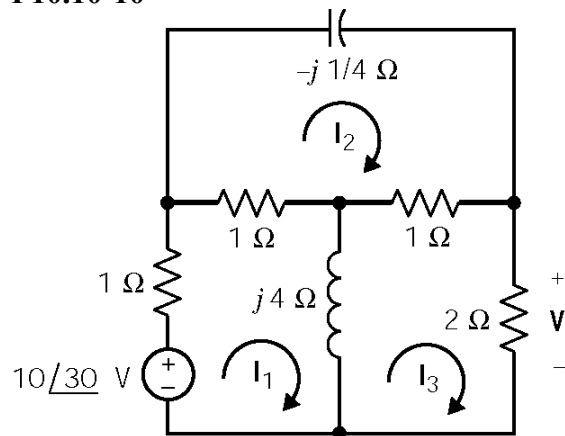

The mesh equations are:

$$\begin{bmatrix} (2+j4) & -1 & -j4 \\ -1 & (2+1/j4) & -1 \\ -j4 & -1 & (3+j4) \end{bmatrix} \begin{bmatrix} \mathbf{I}_1 \\ \mathbf{I}_2 \\ \mathbf{I}_3 \end{bmatrix} = \begin{bmatrix} 10 \angle 30^\circ \\ 0 \\ 0 \end{bmatrix}$$

Using Cramer's rule yields

$$\mathbf{I}_3 = \frac{2+j8}{12+j22.5} (10 \angle 30^\circ) = 3.225 \angle 44^\circ \text{ A}$$

Then

$$\mathbf{V} = 2 \mathbf{I}_3 = 2(3.225 \angle 44^\circ) = 6.45 \angle 44^\circ \text{ V} \Rightarrow v(t) = 6.45 \cos(10^5 t + 44^\circ) \text{ V}$$

P10.10-11

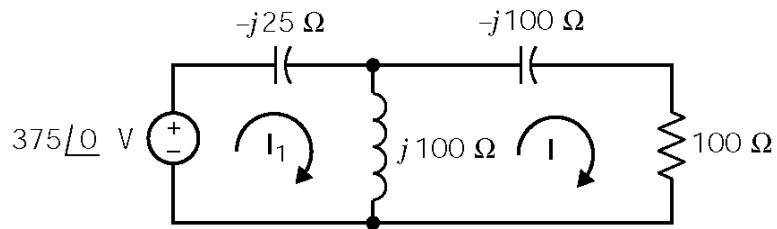

Mesh Equations:

$$j 75 \mathbf{I}_1 - j 100 \mathbf{I}_2 = 375$$

$$-j 100 \mathbf{I}_1 + (100 + j 100) \mathbf{I}_2 = 0$$

Solving for \mathbf{I}_2 yields $\mathbf{I}_2 = 4.5 + j 1.5 \text{ A} \Rightarrow i_2(t) = 4.74 \angle 18.4^\circ \text{ A}$

Section 10-11: Superposition, Thévenin and Norton Equivalents and Source Transformations

P10.11-1

Use superposition

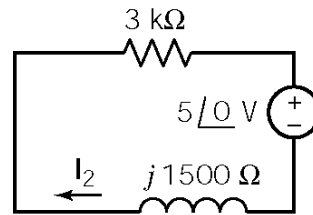
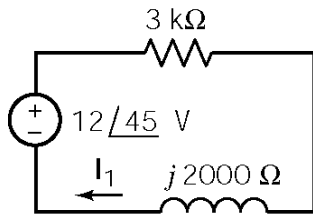

$$I_1 = \frac{12\angle 45^\circ}{3000 + j2000} = 3.3\angle 11.3^\circ \text{ mA}$$

$$I_2 = \frac{-5\angle 0^\circ}{3000 + j1500} = 1.5\angle 153^\circ \text{ mA}$$

$$i(t) = 3.3 \cos(4000t + 11.3^\circ) + 1.5 \cos(3000t + 153^\circ) \text{ mA}$$

P10.11-2

Use superposition

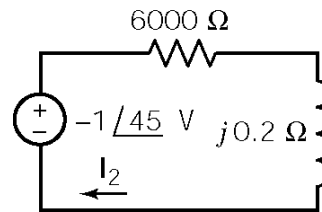
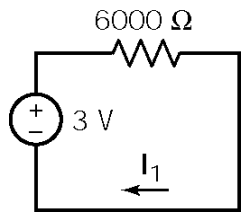

$$I_1 = \frac{3}{6000} = 0.5 \text{ mA}$$

$$I_2(\omega) = \frac{-1\angle 45^\circ}{6000 + j0.2} = -0.166 \times 10^{-3} \angle 45^\circ \text{ A}$$

$$i(t) = i_2(t) + i_1(t) = -0.166 \cos(4t + 45^\circ) + 0.5 \text{ mA}$$

$$= 0.166 \cos(4t - 135^\circ) + 0.5 \text{ mA}$$

P10.11-3

Use superposition

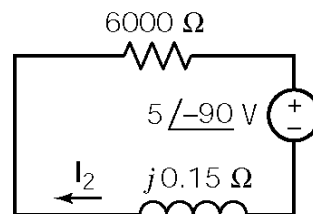
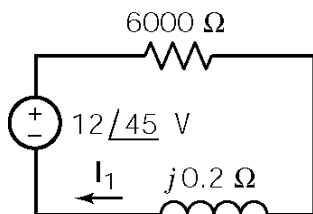

$$I_1(\omega) = \frac{12\angle 45^\circ}{6000 + j0.2} = 2\angle 45^\circ \text{ mA}$$

$$I_2(\omega) = \frac{5\angle -90^\circ}{6000 + j0.15} = 0.833\angle -90^\circ \text{ mA}$$

$$i(t) = i_1(t) - i_2(t) = 2 \cos(4t + 45^\circ) - 0.833 \cos(3t - 90^\circ) \text{ mA}$$

P10.11-4

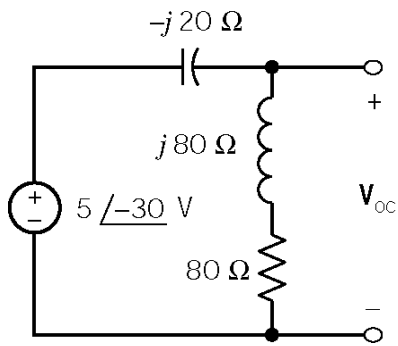

Find V_{oc} :

$$\begin{aligned} V_{oc} &= (5 \angle -30^\circ) \left(\frac{80 + j80}{80 + j80 - j20} \right) \\ &= (5 \angle -30^\circ) \left(\frac{80\sqrt{2} \angle -21.9^\circ}{100 \angle 36.9^\circ} \right) \\ &= 4\sqrt{2} \angle -21.9^\circ \text{ V} \end{aligned}$$

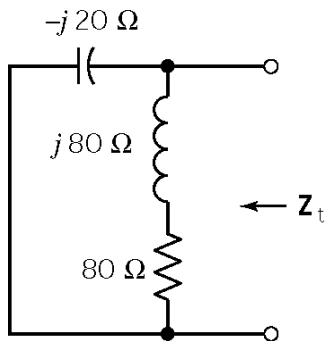

Find Z_t :

$$Z_t = \frac{(-j20)(80 + j80)}{-j20 + 80 + j80} = 23 \angle -81.9^\circ \Omega$$

The Thevenin equivalent is

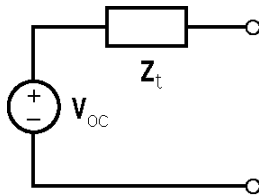

P10.11-5

First, determine V_{oc} :

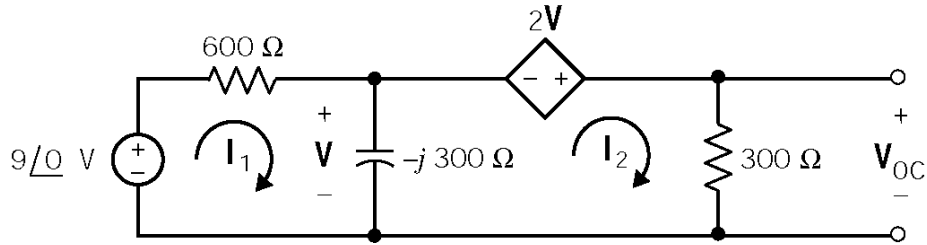

The mesh equations are

$$600\mathbf{I}_1 - j300(\mathbf{I}_1 - \mathbf{I}_2) = 9 \Rightarrow (600 - j300)\mathbf{I}_1 + j300\mathbf{I}_2 = 9\angle 0^\circ$$

$$-2\mathbf{V} + 300\mathbf{I}_2 - j300(\mathbf{I}_1 - \mathbf{I}_2) = 0 \quad \text{and} \quad \mathbf{V} = j300(\mathbf{I}_1 - \mathbf{I}_2) \Rightarrow j3\mathbf{I}_1 + (1 - j3)\mathbf{I}_2 = 0$$

Using Cramer's rule:

$$\mathbf{I}_2 = 0.0124\angle -16^\circ \text{ A}$$

Then

$$\mathbf{V}_{oc} = 300\mathbf{I}_2 = 3.71\angle -16^\circ \text{ V}$$

Next, determine \mathbf{I}_{sc} :

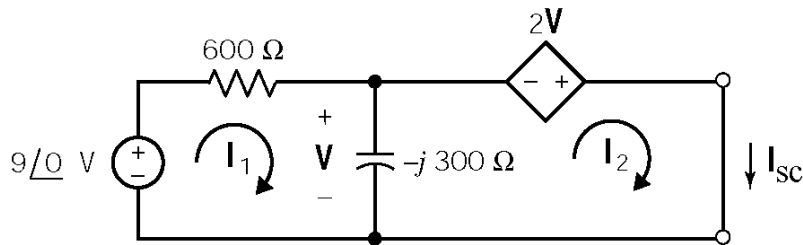

$$-2\mathbf{V} - \mathbf{V} = 0 \Rightarrow \mathbf{V} = 0 \Rightarrow \mathbf{I}_{sc} = \frac{9\angle 0^\circ}{600} = 0.015\angle 0^\circ \text{ A}$$

The Thevenin impedance is

$$\mathbf{Z}_T = \frac{\mathbf{V}_{oc}}{\mathbf{I}_{sc}} = \frac{3.71\angle -16^\circ}{0.015\angle 0^\circ} = 247\angle -16^\circ \Omega$$

The Thevenin equivalent is

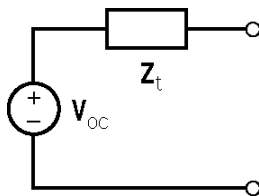

P10.11-6

First, determine V_{oc} :

The node equation is:

$$\frac{V_{oc}}{-j4} + \frac{V_{oc} - (6 + j8)}{j2} - \frac{3}{2} \left(\frac{V_{oc} - (6 + j8)}{j2} \right) = 0$$

$$V_{oc} = 3 + j4 = 5 \angle 53.1^\circ \text{ V}$$

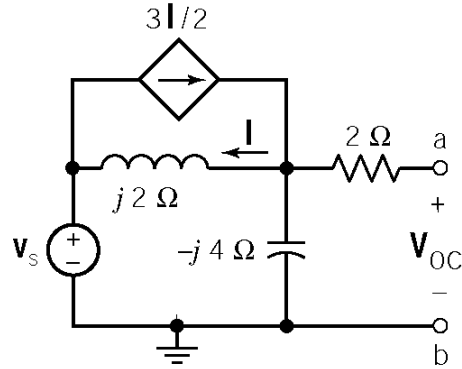

$$V_s = 10 \angle 53^\circ = 6 + j8 \text{ V}$$

Next, determine I_{sc} :

The node equation is:

$$\frac{V}{2} + \frac{V}{-j4} + \frac{V - (6 + j8)}{j2} - \frac{3}{2} \left[\frac{V - (6 + j8)}{j2} \right] = 0$$

$$V = \frac{3 + j4}{1 - j}$$

$$I_{sc} = \frac{V}{2} = \frac{3 + j4}{2 - j2}$$

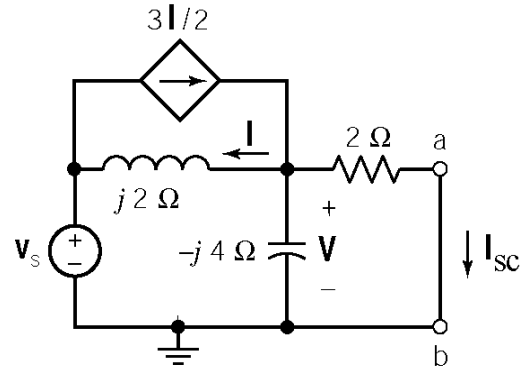

$$V_s = 10 \angle 53^\circ = 6 + j8 \text{ V}$$

The Thevenin impedance is

$$Z_T = \frac{V_{oc}}{I_{sc}} = 3 + j4 \left(\frac{2 - j2}{3 + j4} \right) = 2 - j2 \ \Omega$$

The Thevenin equivalent is

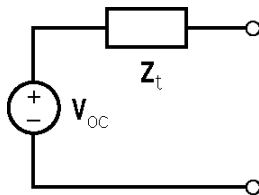

P10.11-7

$$Y = G + Y_L + Y_C$$

$$Y = G \text{ when } Y_L + Y_C = 0 \text{ or } \frac{1}{j\omega L} + j\omega C = 0$$

$$\omega_o = \frac{1}{\sqrt{LC}}, f_o = \frac{1}{2\pi\sqrt{LC}} = \frac{1}{2\pi\sqrt{39.6 \times 10^{-15}}}$$

$$= 0.07998 \times 10^7 \text{ Hz} = 800 \text{ KHz}$$

(80 on the dial of the radio)

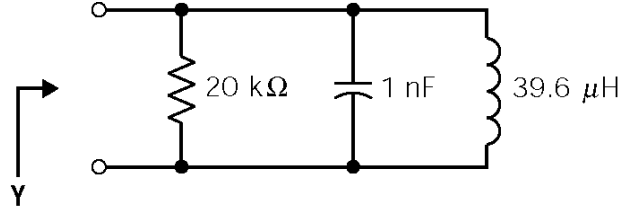

P10.11-8

In general:

$$I = \frac{V_{oc}}{Z_t + Z_L} \text{ and } V = \frac{Z_L}{Z_t + Z_L} V_{oc}$$

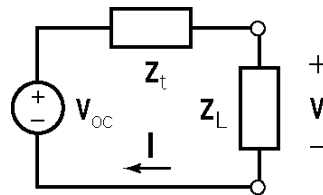

In the three given cases, we have

$$Z_1 = 50 \Omega \Rightarrow |I_1| = \frac{|V_1|}{|Z_1|} = \frac{25}{50} = 0.5 \text{ A}$$

$$Z_2 = \frac{1}{j\omega C} = \frac{1}{j(2000)(2.5 \times 10^{-6})} = -j200 \Omega \Rightarrow |I_2| = \frac{|V_2|}{|Z_2|} = \frac{100}{200} = 0.5 \text{ A}$$

$$Z_3 = j\omega L = j(2000)(50 \times 10^{-3}) = j100 \Omega \Rightarrow |I_3| = \frac{|V_3|}{|Z_3|} = \frac{50}{100} = 0.5 \text{ A}$$

Since $|I|$ is the same in all three cases, $|Z_t + Z_1| = |Z_t + Z_2| = |Z_t + Z_3|$. Let $Z_t = R + jX$. Then

$$(R + 50)^2 + X^2 = R^2 + (X - 200)^2 = R^2 + (X + 100)^2$$

This requires

$$(X - 200)^2 = (X + 100)^2 \Rightarrow X = 50 \Omega$$

Then

$$(R + 50)^2 + (50)^2 = R^2 + (-150)^2 \Rightarrow R = 175 \Omega$$

so

$$Z_t = 175 + j50 \Omega$$

and

$$|V_{oc}| = |I_1| |Z_t + R_1| = (0.5) \sqrt{(175 + 50)^2 + (50)^2} = 115.25 \text{ V}$$

P10.11-9

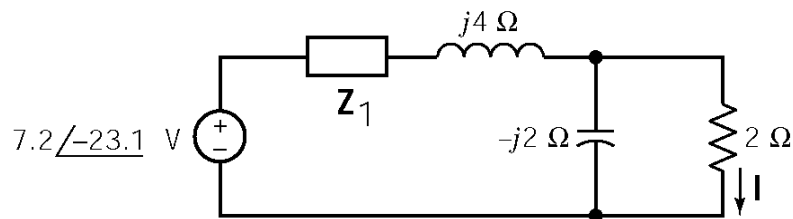
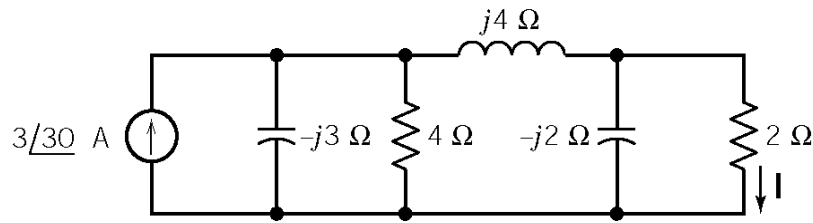

$$\begin{aligned} \mathbf{Z}_1 &= \frac{(-j3)(4)}{-j3+4} = 2.4 \angle -53.1^\circ \Omega \\ &= 1.44 - j1.92 \Omega \end{aligned}$$

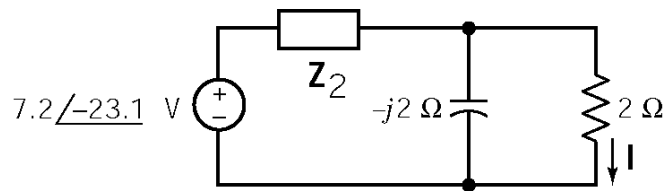

$$\begin{aligned} \mathbf{Z}_2 &= \mathbf{Z}_1 + j4 \\ &= 1.44 + j2.08 \\ &= 2.53 \angle 55.3^\circ \Omega \end{aligned}$$

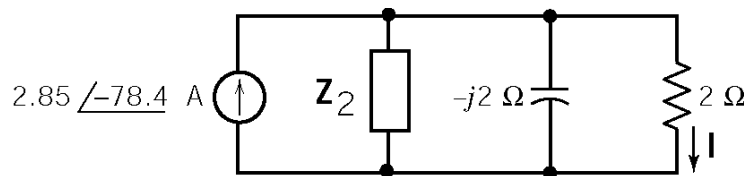

$$\begin{aligned} \mathbf{Z}_3 &= 3.51 \angle -37.9^\circ \Omega \\ &= 2.77 - j2.16 \Omega \end{aligned}$$

$$\mathbf{I} = (2.85 \angle -78.4^\circ) \left(\frac{3.51 \angle -37.9^\circ}{2.77 - j2.16 + 2} \right) = (2.85 \angle -78.4^\circ) \frac{(3.51 \angle -37.9^\circ)}{(5.24 \angle -24.4^\circ)} = 1.9 \angle -92^\circ \text{ A}$$

P10.11-10

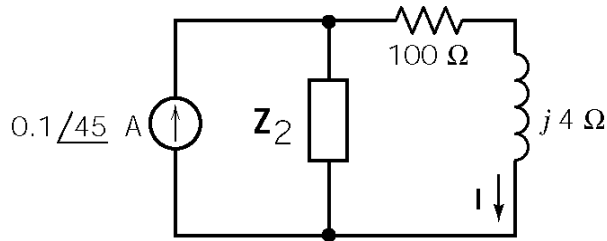
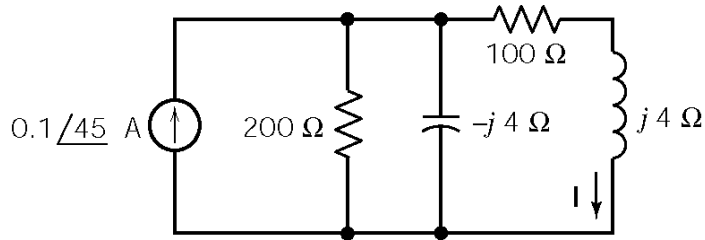
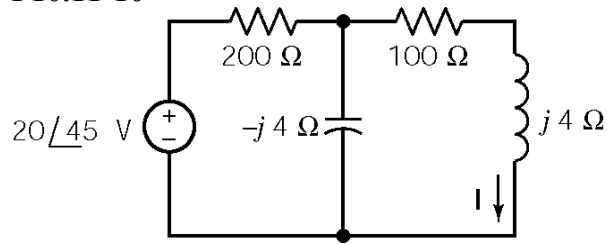

$$Z_2 = \frac{(200)(-j4)}{200-j4} = 4\angle -88.8^\circ \Omega$$

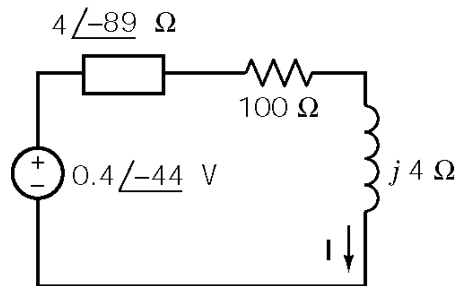

$$I = \frac{0.4\angle -44^\circ}{-4j+100+j4} = 4\angle -44^\circ \text{ mA}$$

$$i(t) = 4 \cos(25000t - 44^\circ) \text{ mA}$$

Section 10-12: Phasor Diagrams

P10-12-1

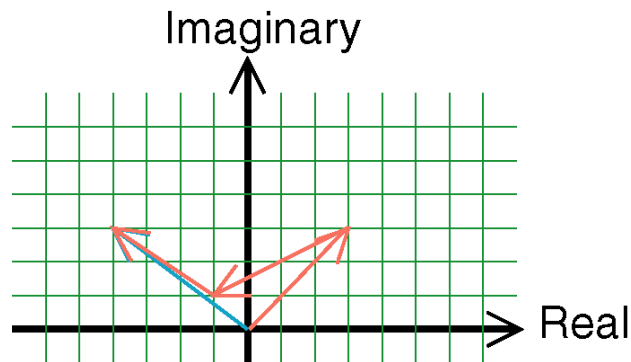

$$\mathbf{V} = \mathbf{V}_1 - \mathbf{V}_2 + \mathbf{V}_3^* = (3 + j3) - (4 + j2) + (3 + j2)^* = -4 + j3$$

P10.12-2

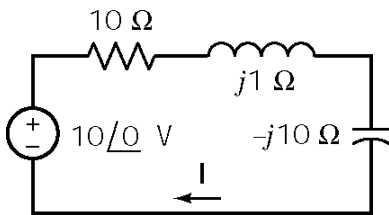

$$\mathbf{I} = \frac{10\angle 0^\circ}{10 + j1 - j10} = 0.74\angle 42^\circ \text{ A}$$

$$\mathbf{V}_R = R\mathbf{I} = 7.4\angle 42^\circ \text{ V}$$

$$\mathbf{V}_L = \mathbf{Z}_L\mathbf{I} = (1\angle 90^\circ)(0.74\angle 42^\circ) = 0.74\angle 132^\circ \text{ V}$$

$$\mathbf{V}_C = \mathbf{Z}_C\mathbf{I} = (10\angle -90^\circ)(0.74\angle 42^\circ) = 7.4\angle -48^\circ \text{ V}$$

$$\mathbf{V}_S = 10\angle 0^\circ \text{ V}$$

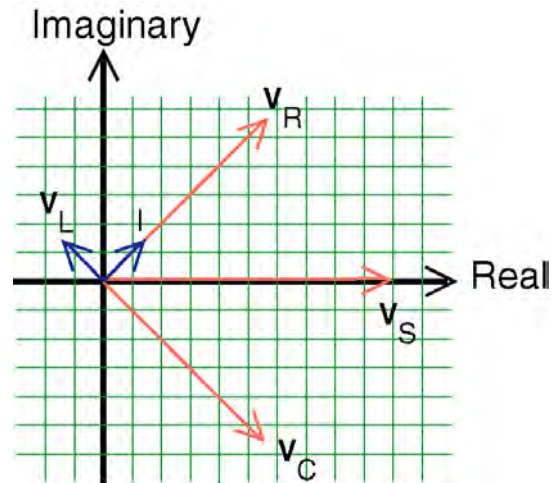

P10.12-3

$$\begin{aligned} \mathbf{I} &= 72\sqrt{3} + 36\sqrt{3}\angle(140^\circ - 90^\circ) + 144\angle 210^\circ + 25\angle \phi = 40.08 - j24.23 + 25\angle \phi \\ &= 46.83\angle -31.15^\circ + 25\angle \phi \end{aligned}$$

To maximize $|\mathbf{I}|$, require that the 2 terms on the right side have the same angle $\Rightarrow \phi = -31.15^\circ$.

Section 10-14: Phasor Circuits and the Operational Amplifier

P10.14-1

$$\mathbf{H}(\omega) = \frac{\mathbf{V}_o(\omega)}{\mathbf{V}_s(\omega)} = -\left(\frac{10^4 \parallel -j10^4}{1000}\right) = -10 \frac{-j}{1-j} = \frac{10}{\sqrt{2}} e^{-j225^\circ}$$

$$\mathbf{V}_s(\omega) = \sqrt{2} \Rightarrow \mathbf{V}_o(\omega) = \left(\frac{10}{\sqrt{2}} e^{-j225^\circ}\right) \sqrt{2} = 10 e^{-j225^\circ}$$

$$v_o(t) = 10 \cos(1000t - 225^\circ) \text{ V}$$

P10.14-2

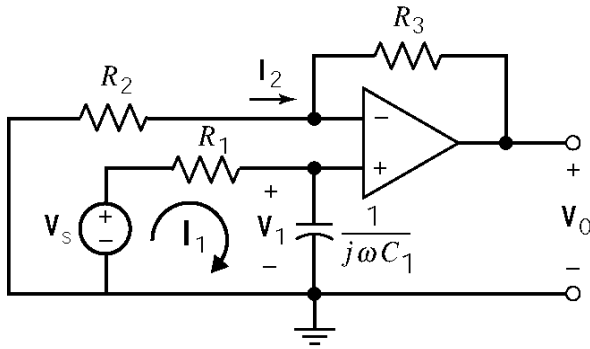

Node equations:

$$\frac{\mathbf{V}_1 - \mathbf{V}_s}{R_1} + j\omega C_1 \mathbf{V}_1 = 0 \Rightarrow \mathbf{V}_1 = \frac{\mathbf{V}_s}{1 + j\omega C_1 R_1}$$

$$\frac{\mathbf{V}_1}{R_2} + \frac{\mathbf{V}_1 - \mathbf{V}_0}{R_3} = 0 \Rightarrow \mathbf{V}_0 = \left(1 + \frac{R_3}{R_2}\right) \mathbf{V}_1$$

Solving:

$$\frac{\mathbf{V}_0}{\mathbf{V}_s} = \frac{1 + \frac{R_3}{R_2}}{1 + j\omega C_1 R_1}$$

P10.14-3

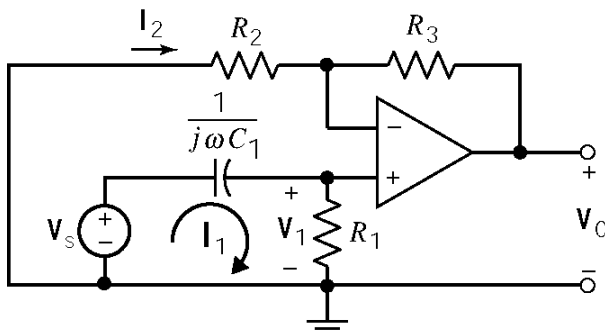

Node equations:

$$\frac{\mathbf{V}_1}{R_1} + j\omega C_1 (\mathbf{V}_1 - \mathbf{V}_s) = 0 \Rightarrow \mathbf{V}_1 = \frac{j\omega C_1 \mathbf{V}_s}{1 + j\omega C_1 R_1}$$

$$\frac{\mathbf{V}_1}{R_2} + \frac{\mathbf{V}_1 - \mathbf{V}_0}{R_3} = 0 \Rightarrow \mathbf{V}_0 = \left(1 + \frac{R_3}{R_2}\right) \mathbf{V}_1$$

Solving:

$$\frac{\mathbf{V}_0}{\mathbf{V}_s} = \frac{j\omega C_1 \left(1 + \frac{R_3}{R_2}\right)}{1 + j\omega C_1 R_1}$$

P10.14-4

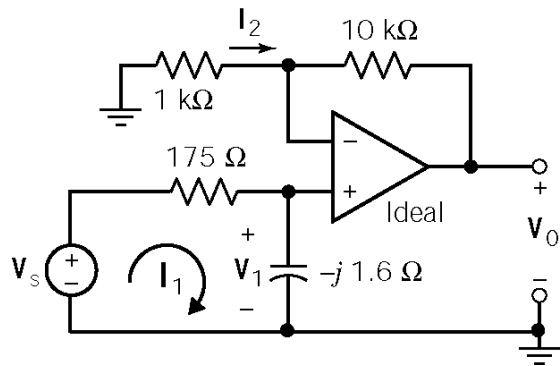

Node equations:

$$\frac{V_1 - V_s}{175} + \frac{V_1}{-j1.6} = 0 \Rightarrow V_1 = \frac{V_s}{1 + j109}$$

$$\frac{V_1}{1000} + \frac{V_1 - V_0}{10000} = 0 \Rightarrow V_0 = 11V_1$$

Solving:

$$\begin{aligned} V_0 &= \frac{11}{1 + j109} V_s = \frac{11}{110 \angle 89.5^\circ} (0.005 \angle 0^\circ) \\ &= 0.5 \angle 89.5^\circ \text{ mV} \end{aligned}$$

Therefore

$$v_0(t) = 0.5 \cos(\omega t - 89.5^\circ) \text{ mV}$$

PSpice Problems

SP10-1

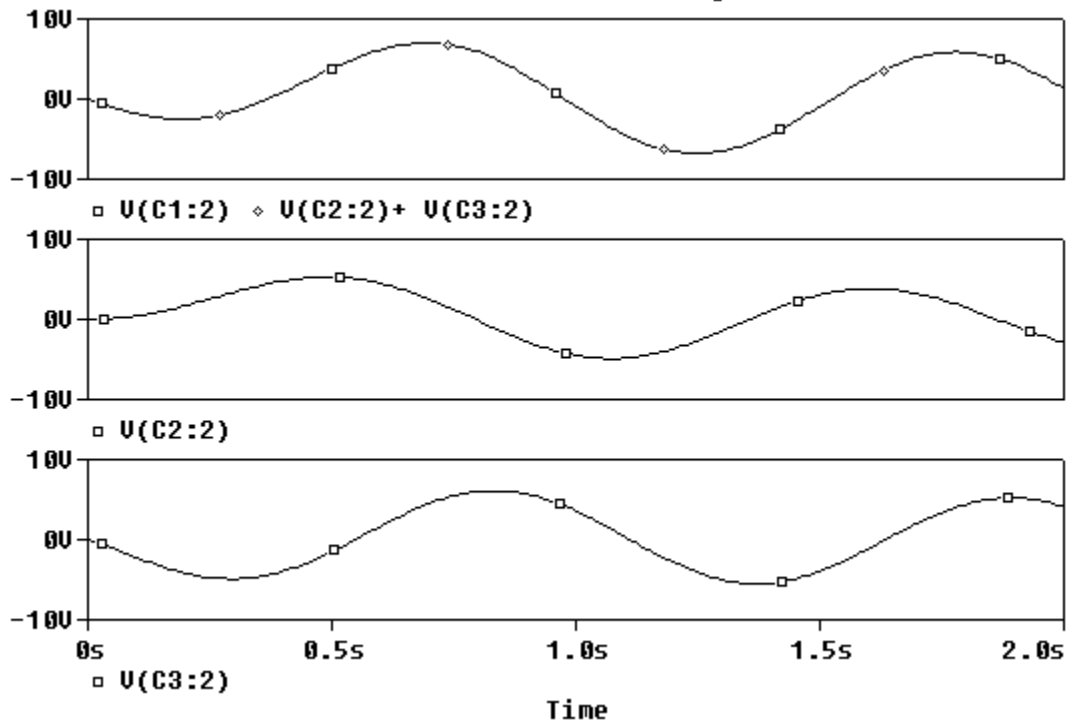
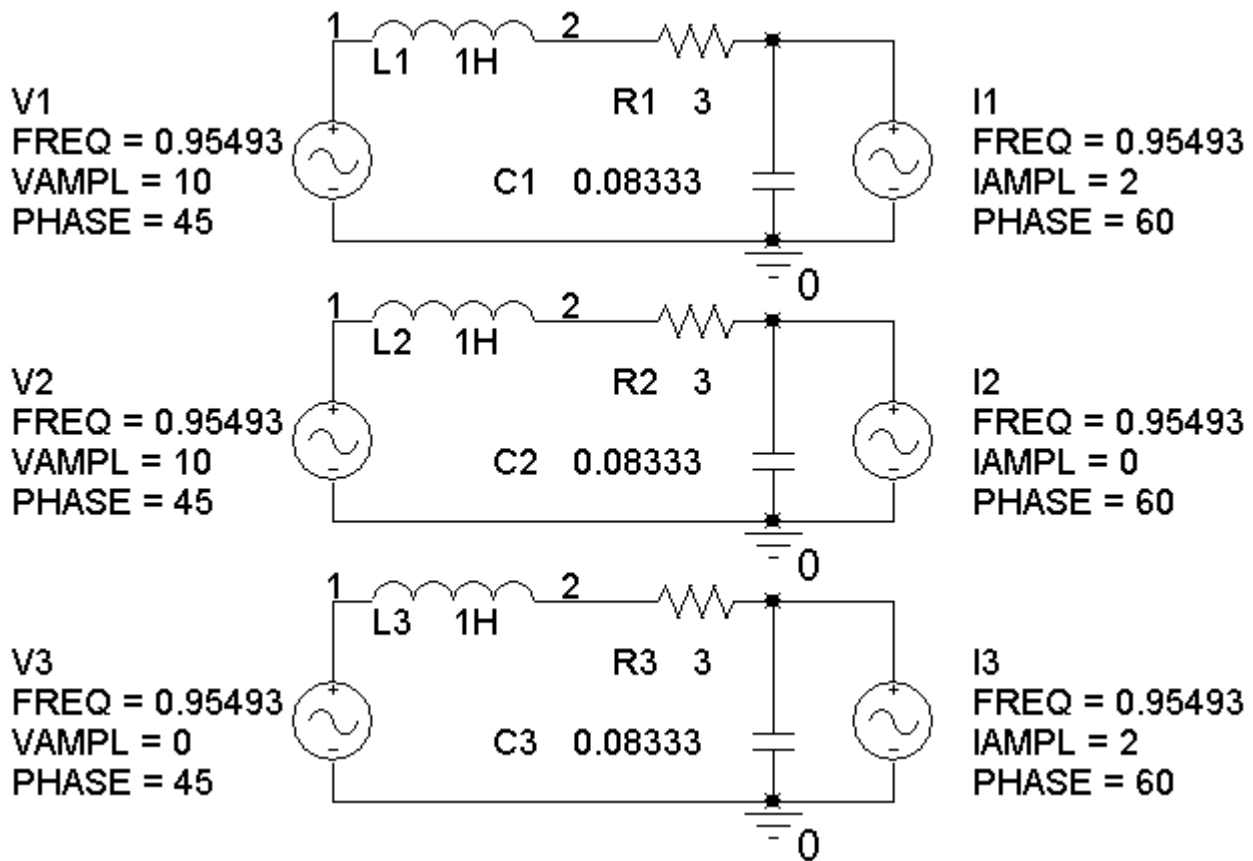

SP10-2

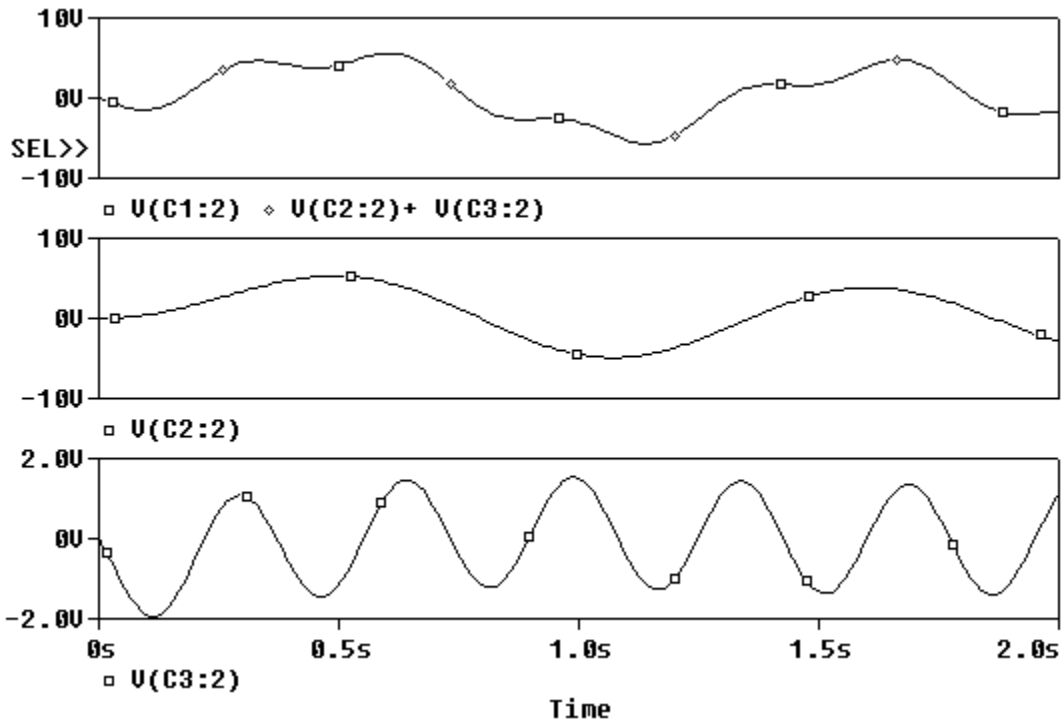
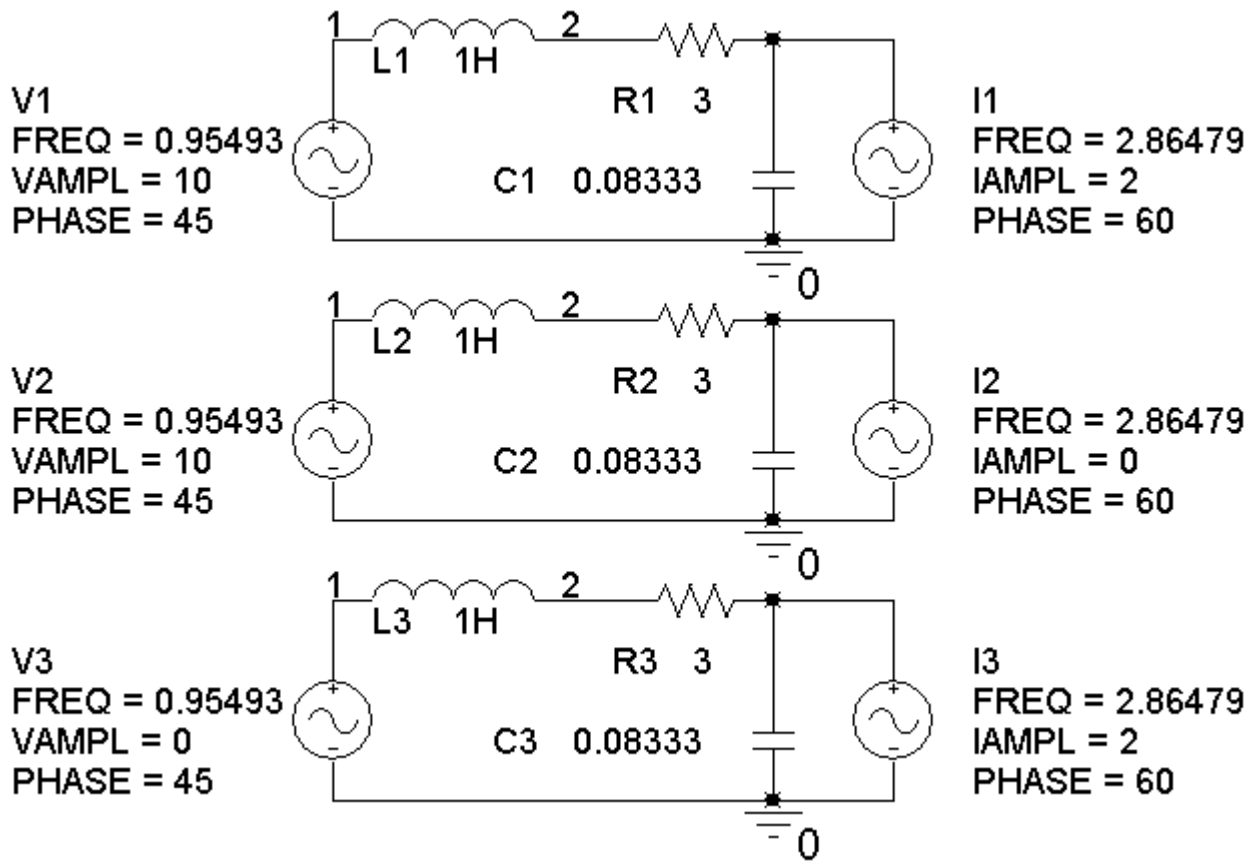

SP 10-3

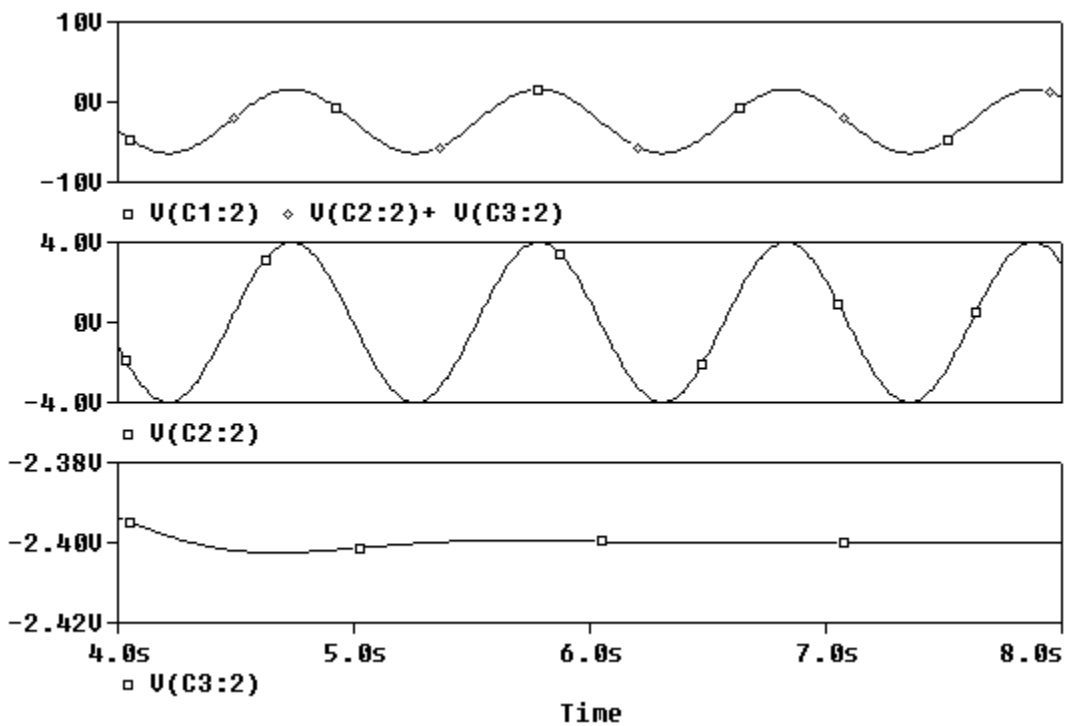
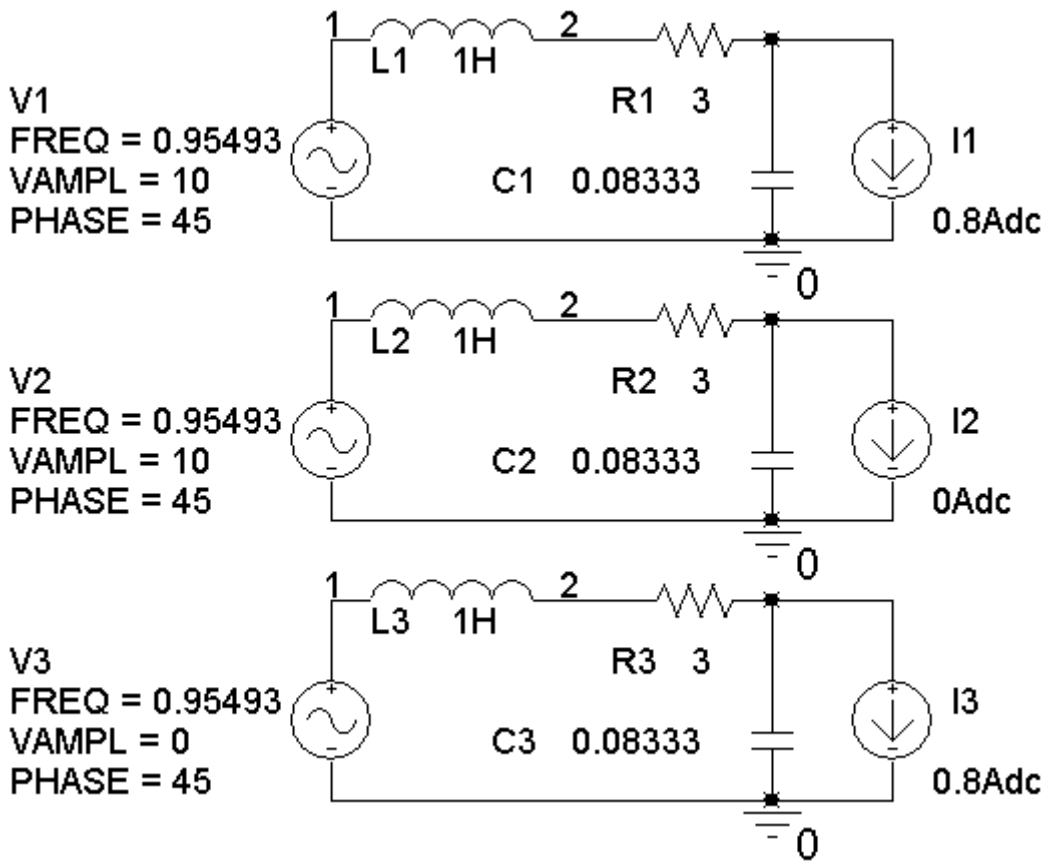

SP 10-4 The following simulation shows that $k_1 = 0.4$ and $k_2 = -3$ V/A. The required values of V_m and I_m are $V_m = 12.5$ V and $I_m = -1.667$ A.

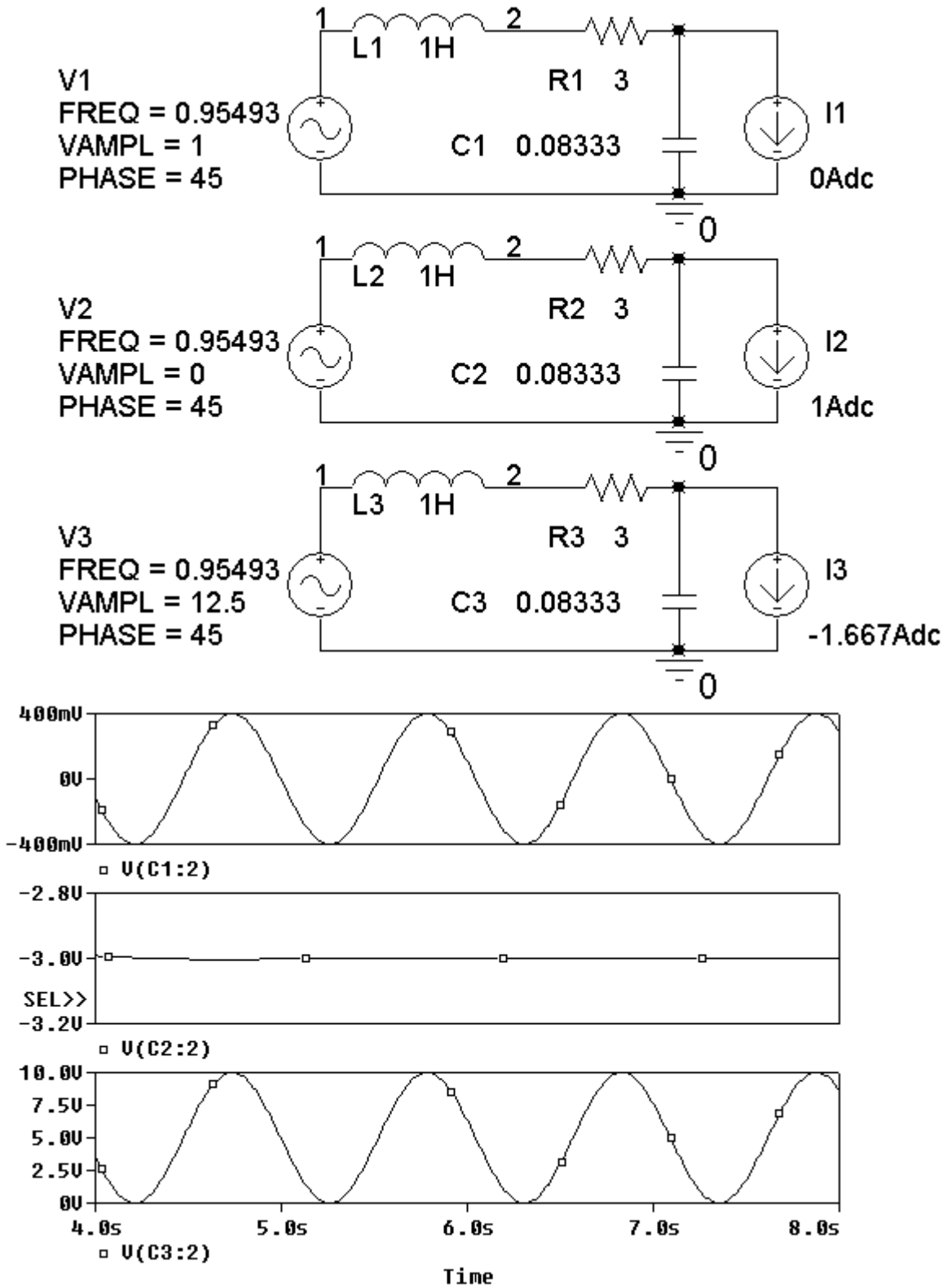

Verification Problems

VP 10-1

Generally, it is more convenient to divide complex numbers in polar form. Sometimes, as in this case, it is more convenient to do the division in rectangular form.

Express \mathbf{V}_1 and \mathbf{V}_2 as: $\mathbf{V}_1 = -j20$ and $\mathbf{V}_2 = 20 - j40$

KCL at node 1:

$$2 - \frac{\mathbf{V}_1}{10} - \frac{\mathbf{V}_1 - \mathbf{V}_2}{j10} = 2 - \frac{-j20}{10} - \frac{-j20 - (20 - j40)}{j10} = 2 + j2 - 2 - j2 = 0$$

KCL at node 2:

$$\frac{\mathbf{V}_1 - \mathbf{V}_2}{j10} - \frac{\mathbf{V}_2}{10} + 3\left(\frac{\mathbf{V}_1}{10}\right) = \frac{-j20 - (20 - j40)}{j10} - \frac{20 - j40}{10} + 3\left(\frac{-j20}{10}\right) = (2 + j2) - (2 - j4) - j6 = 0$$

The currents calculated from \mathbf{V}_1 and \mathbf{V}_2 satisfy KCL at both nodes, so it is very likely that the \mathbf{V}_1 and \mathbf{V}_2 are correct.

VP 10-2

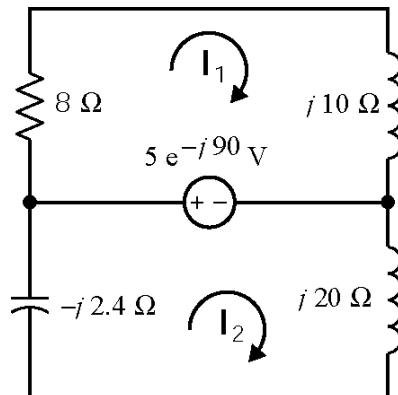

$$\mathbf{I}_1 = 0.390 \angle 39^\circ \text{ and } \mathbf{I}_2 = 0.284 \angle 180^\circ$$

Generally, it is more convenient to multiply complex numbers in polar form. Sometimes, as in this case, it is more convenient to do the multiplication in rectangular form.

$$\text{Express } \mathbf{I}_1 \text{ and } \mathbf{I}_2 \text{ as: } \mathbf{I}_1 = 0.305 + j0.244 \text{ and } \mathbf{I}_2 = -0.284$$

KVL for mesh 1:

$$8(0.305 + j0.244) + j10(0.305 + j0.244) - (-j5) = j10$$

Since KVL is not satisfied for mesh 1, the mesh currents are not correct.

Here is a MATLAB file for this problem:

```

% Impedance and phasors for Figure VP 10-2
Vs = -j*5;
Z1 = 8;
Z2 = j*10;
Z3 = -j*2.4;
Z4 = j*20;

% Mesh equations in matrix form
Z = [ Z1+Z2    0;
      0      Z3+Z4 ];
V = [ Vs;
      -Vs ];
I = Z\V
abs(I)
angle(I)*180/3.14159

% Verify solution by obtaining the algebraic sum of voltages for
% each mesh. KVL requires that both M1 and M2 be zero.
M1 = -Vs + Z1*I(1) + Z2*I(1)
M2 = Vs + Z3*I(2) + Z4*I(2)

```

VP 10-3

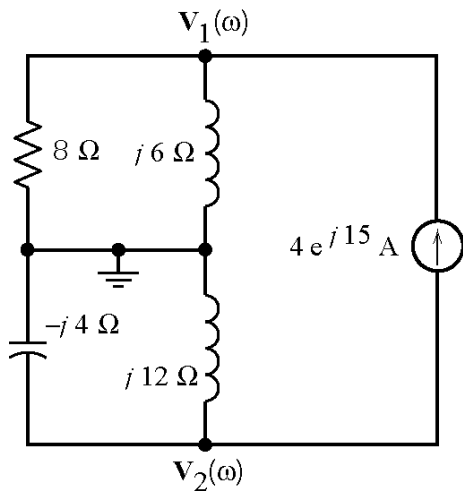

$$\mathbf{V}_1 = 19.2 \angle 68^\circ \text{ and } \mathbf{V}_2 = 24 \angle 105^\circ \text{ V}$$

KCL at node 1 :

$$\frac{19.2 \angle 68^\circ}{2} + \frac{19.2 \angle 68^\circ}{j6} - 4 \angle 15 = 0$$

KCL at node 2:

$$\frac{24 \angle 105^\circ}{-j4} + \frac{24 \angle 105^\circ}{j12} + 4 \angle 15 = 0$$

The currents calculated from \mathbf{V}_1 and \mathbf{V}_2 satisfy KCL at both nodes, so it is very likely that the \mathbf{V}_1 and \mathbf{V}_2 are correct.

Here is a MATLAB file for this problem:

```

% Impedance and phasors for Figure VP 10-3
Is = 4*exp(j*15*3.14159/180);
Z1 = 8;
Z2 = j*6;
Z3 = -j*4;

```

$$Z_4 = j*12;$$

`% Mesh equations in matrix form`

$$Y = \begin{bmatrix} 1/Z_1 + 1/Z_2 & 0; \\ 0 & 1/Z_3 + 1/Z_4 \end{bmatrix};$$

$$I = \begin{bmatrix} I_s; \\ -I_s \end{bmatrix};$$

$$V = Y \backslash I$$

$$\text{abs}(V)$$

$$\text{angle}(V) * 180 / 3.14159$$

`% Verify solution by obtaining the algebraic sum of currents for
% each node. KCL requires that both M1 and M2 be zero.`

$$M1 = -I_s + V(1)/Z_1 + V(1)/Z_2$$

$$M2 = I_s + V(2)/Z_3 + V(2)/Z_4$$

VP 10-4

First, replace the parallel resistor and capacitor by an equivalent impedance

$$Z_p = \frac{(3000)(-j1000)}{3000 - j1000} = 949 \angle -72^\circ = 300 - j900 \Omega$$

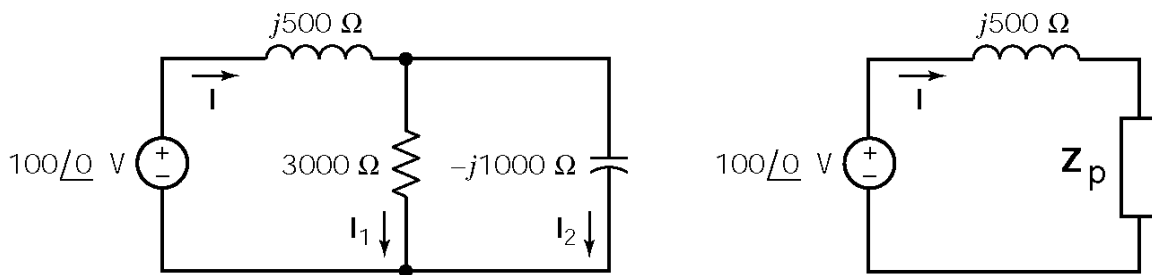

The current is given by

$$I = \frac{V_s}{j500 + Z_p} = \frac{100 \angle 0^\circ}{j500 + 300 - j900} = 0.2 \angle 53^\circ \text{ A}$$

Current division yields

$$I_1 = \left(\frac{-j1000}{3000 - j1000} \right) (0.2 \angle 53^\circ) = 63.3 \angle -18.5^\circ \text{ mA}$$

$$I_2 = \left(\frac{3000}{3000 - j1000} \right) (0.2 \angle 53^\circ) = 190 \angle 71.4^\circ \text{ mA}$$

The reported value of I_1 is off by an order of magnitude.

Design Problems

DP 10-1

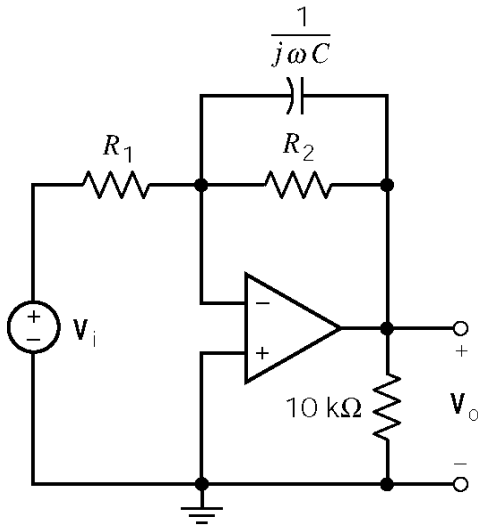

$$R_2 \left\| \frac{1}{j\omega C} = \frac{R_2}{1 + j\omega CR_2}$$

$$\frac{V_o(\omega)}{V_i(\omega)} = -\frac{\frac{R_2}{1 + j\omega CR_2}}{R_1} = -\frac{R_2}{R_1(1 + j\omega CR_2)}$$

$$\frac{V_o(\omega)}{V_i(\omega)} = \frac{\frac{R_2}{R_1}}{\sqrt{1 + (\omega CR_2)^2}} e^{j(180 - \tan^{-1} \omega CR_2)}$$

In this case the angle of $\frac{V_o(\omega)}{V_i(\omega)}$ is specified to be 104° so $CR_2 = \frac{\tan(180 - 76)}{1000} = 0.004$ and the

magnitude of $\frac{V_o(\omega)}{V_i(\omega)}$ is specified to be $\frac{8}{2.5}$ so $\frac{\frac{R_2}{R_1}}{\sqrt{1+16}} = \frac{8}{2.5} \Rightarrow \frac{R_2}{R_1} = 132$. One set of values that satisfies these two equations is $C = 0.2 \mu\text{F}$, $R_1 = 1515 \Omega$, $R_2 = 20 \text{ k}\Omega$.

DP 10-2

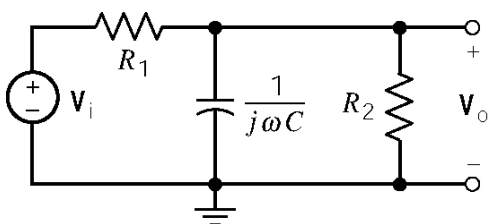

$$R_2 \left\| \frac{1}{j\omega C} = \frac{R_2}{1 + j\omega CR_2}$$

$$\frac{V_o(\omega)}{V_i(\omega)} = \frac{\frac{R_2}{1 + j\omega CR_2}}{R_1 + \frac{R_2}{1 + j\omega CR_2}} = \frac{K}{1 + j\omega CR_p}$$

where $K = \frac{R_1}{R_1 + R_2}$ and $R_p = \frac{R_1 R_2}{R_1 + R_2}$

$$\frac{V_o(\omega)}{V_i(\omega)} = \frac{K}{\sqrt{1 + (\omega CR_p)^2}} e^{-j \tan^{-1} \omega CR_p}$$

In this case the angle of $\frac{V_o(\omega)}{V_i(\omega)}$ is specified to be -76° so

$$C R_p = C \frac{R_1 R_2}{R_1 + R_2} = -\frac{\tan(-76)}{1000} = 0.004 \text{ and the magnitude of } \frac{V_o(\omega)}{V_i(\omega)} \text{ is specified to be } \frac{2.5}{12} \text{ so}$$

$$\frac{K}{\sqrt{1+16}} = \frac{2.5}{12} \Rightarrow 0.859 = K = \frac{R_2}{R_1 + R_2}. \text{ One set of values that satisfies these two equations is}$$

$$C = 0.2 \mu\text{F}, R_1 = 23.3 \text{ k}\Omega, R_2 = 142 \text{ k}\Omega.$$

DP 10-3

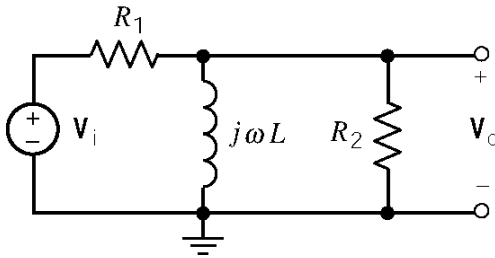

$$\frac{V_o(\omega)}{V_i(\omega)} = \frac{\frac{j\omega L R_2}{R_2 + j\omega L}}{R_1 + \frac{j\omega L R_2}{R_2 + j\omega L}} = -\frac{j\omega \frac{L}{R_1}}{1 + j\omega \frac{L}{R_p}}$$

$$\text{where } R_p = \frac{R_1 R_2}{R_1 + R_2}$$

$$\frac{V_o(\omega)}{V_i(\omega)} = \frac{\omega \frac{L}{R_1}}{\sqrt{1 + \left(\omega \frac{L}{R_p}\right)^2}} e^{j\left(90 - \tan^{-1} \omega \frac{L}{R_p}\right)}$$

In this case the angle of $\frac{V_o(\omega)}{V_i(\omega)}$ is specified to be 14° so $\frac{L}{R_p} = \frac{L(R_1 + R_2)}{R_1 R_2} = \frac{\tan(90 - 14)}{40} = 0.1$

and the magnitude of $\frac{V_o(\omega)}{V_i(\omega)}$ is specified to be $\frac{2.5}{8}$ so $\frac{40 \frac{L}{R_1}}{\sqrt{1+16}} = \frac{2.5}{8} \Rightarrow \frac{L}{R_1} = 0.0322$. One

set of values that satisfies these two equations is $L = 1 \text{ H}, R_1 = 31 \Omega, R_2 = 14.76 \Omega$.

DP 10-4

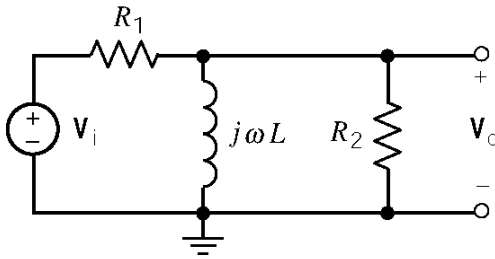

$$\frac{V_o(\omega)}{V_i(\omega)} = \frac{\frac{j\omega L R_2}{R_2 + j\omega L}}{R_1 + \frac{j\omega L R_2}{R_2 + j\omega L}} = \frac{j\omega \frac{L}{R_1}}{1 + j\omega \frac{L}{R_p}}$$

where $R_p = \frac{R_1 R_2}{R_1 + R_2}$

$$\frac{V_o(\omega)}{V_i(\omega)} = \frac{\omega \frac{L}{R_1}}{\sqrt{1 + \left(\omega \frac{L}{R_p}\right)^2}} e^{j\left(90 - \tan^{-1} \omega \frac{L}{R_p}\right)}$$

In this case the angle of $\frac{V_o(\omega)}{V_i(\omega)}$ is specified to be -14° . This requires

$$\frac{L}{R_p} = \frac{L(R_1 + R_2)}{R_1 R_2} = \frac{\tan(90 + 14)}{40} = -0.1$$

This condition cannot be satisfied with positive

DP 10-5

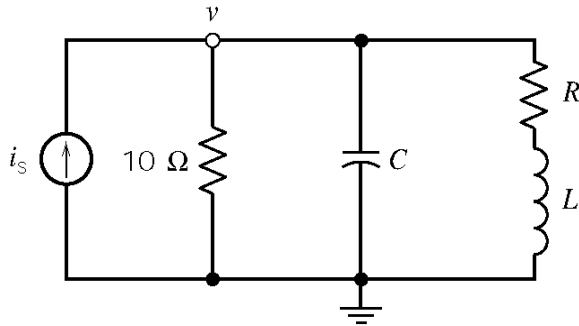

$$\begin{aligned} Z_1 &= 10 \Omega & Y_1 &= \frac{1}{10} \text{ S} \\ Z_2 &= \frac{1}{j\omega C} & Y_2 &= j\omega C \\ Z_3 &= R + j\omega L & Y_3 &= \frac{1}{R + j\omega L} \end{aligned}$$

$$v(t) = 80 \cos(1000t - \theta) \text{ V} \Rightarrow \mathbf{V} = 8\angle -\theta \text{ V}$$

$$i_s(t) = 10 \cos 100t \text{ A} \Rightarrow \mathbf{I}_s = 10\angle 0^\circ \text{ A}$$

so

$$(80\angle -\theta) \left[\frac{1}{10} + \frac{1}{R + j\omega L} + j\omega C \right] = 10\angle 0^\circ \Rightarrow R + 10 - 10\omega^2 LC + j(\omega L + 10\omega RC) = 1.25R + j1.25\omega L$$

Equate real part: $40 - 40\omega^2 LC = R$ where $\omega = 1000$ rad/sec

Equate imaginary part: $40RC = L$

Solving yields $R = 40(1 - 4 \times 10^7 RC^2)$

Now try $R=20\ \Omega \Rightarrow 1-2(1-4\times 10^7(20)C^2)$

which yields $C=2.5\times 10^{-5}\text{ F}=\underline{25\ \mu\text{F}}$ so $L=40\text{ RC}=0.02\text{ H}=\underline{20\text{ mH}}$

Now check the angle of the voltage. First

$$\mathbf{Y}_1 = 1/10 = 0.1\ \text{S}$$

$$\mathbf{Y}_2 = j0.25\ \text{S}$$

$$\mathbf{Y}_3 = 1/(20+j20) = .025-j.025\ \text{S}$$

then

$$\mathbf{Y} = \mathbf{Y}_1 + \mathbf{Y}_2 + \mathbf{Y}_3 = 0.125, \text{ so } \mathbf{V} = \mathbf{Y}\mathbf{I}_s = (0.125\angle 0^\circ)(10\angle 0^\circ) = 1.25\angle 0^\circ\ \text{V}$$

So the angle of the voltage is $\theta = 0^\circ$, which satisfies the specifications.

Chapter 11: AC Steady State Power

Exercises:

Ex. 11.3-1

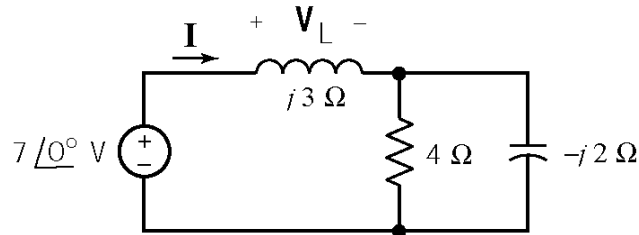

$$\begin{aligned} \mathbf{Z} &= j3 + \frac{4(-j2)}{4-j2} = 0.8 + j1.4 \\ &= 1.6 \angle 60.3^\circ \Omega \\ \therefore \mathbf{I} &= \frac{\mathbf{V}}{\mathbf{Z}} = \frac{7 \angle 0^\circ}{1.6 \angle 60.3^\circ} = 4.38 \angle -60.3^\circ \text{ A} \end{aligned}$$

$$i(t) = 4.38 \cos(10t - 60.3^\circ) \text{ A}$$

The instantaneous power delivered by the source is given by

$$\begin{aligned} p(t) &= v(t) \cdot i(t) = (7 \cos 10t)(4.38 \cos(10t - 60.3^\circ)) = \frac{(7)(4.38)}{2} [\cos(60.3^\circ) + \cos(20t - 60.3^\circ)] \\ &= 7.6 + 15.3 \cos(20t - 60.3^\circ) \text{ W} \end{aligned}$$

The inductor voltage is calculated as

$$\mathbf{V}_L = \mathbf{I} \cdot \mathbf{Z}_L = (4.38 \angle -60.3^\circ)(j3) = 13.12 \angle 29.69^\circ \text{ V}$$

$$v_L(t) = 13.12 \cos(10t + 29.69^\circ) \text{ V}$$

The instantaneous power delivered to the inductor is given by

$$\begin{aligned} p_L(t) &= v_L(t) \cdot i(t) = [(13.12 \cos(10t + 29.69^\circ))(4.38 \cos(10t - 60.3^\circ))] \\ &= \frac{57.47}{2} [\cos(29.69^\circ + 60.3^\circ) + \cos(20t + 29.69^\circ - 60.3^\circ)] \\ &= 28.7 \cos(20t - 30.6^\circ) \text{ W} \end{aligned}$$

Ex. 11.3-2

(a) When the element is a resistor, the current has the same phase angle as the voltage:

$$i(t) = \frac{v(t)}{R} = \frac{V_m}{R} \cos(\omega t + \theta) \text{ A}$$

The instantaneous power delivered to the resistor is given by

$$p_R(t) = v(t) \cdot i(t) = V_m \cos(\omega t + \theta) \cdot \frac{V_m}{R} \cos(\omega t + \theta) = \frac{V_m^2}{R} \cos^2(\omega t + \theta) = \frac{V_m^2}{2R} + \frac{V_m^2}{2R} \cos(2\omega t + \theta)$$



(b) When the element is an inductor, the current will lag the voltage by 90° .

$$\mathbf{Z}_L = j\omega L = \omega L \angle 90^\circ \Omega \quad \Rightarrow \quad \mathbf{I} = \frac{\mathbf{V}}{\mathbf{Z}} = \frac{V_m \angle \theta}{\omega L \angle 90^\circ} = \frac{V_m}{\omega L} \angle (\theta - 90^\circ)$$

The instantaneous power delivered to the inductor is given by

$$p_L(t) = i(t) \cdot v(t) = \frac{V_m}{\omega L} \cos(\omega t + \theta - 90^\circ) \cdot V_m \cos(\omega t + \theta) = \frac{V_m^2}{2\omega L} \cos(2\omega t + 2\theta - 90^\circ) \text{ W}$$

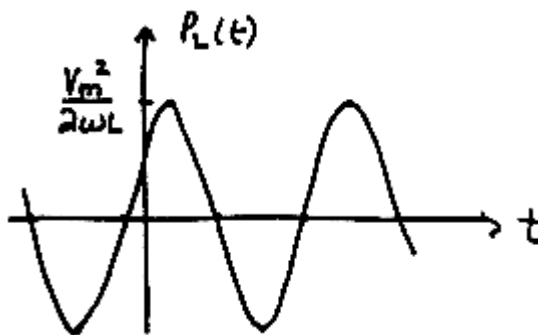

Ex. 11.3-3

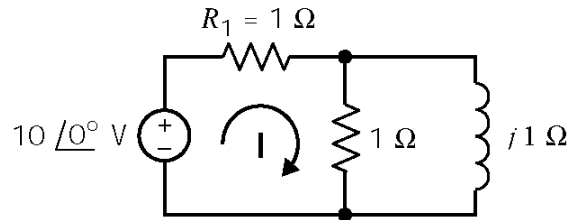

The equivalent impedance of the parallel resistor and inductor is $\mathbf{Z} = \frac{(1)(j)}{1+j} = \frac{1}{2}(1+j) \Omega$. Then

$$\mathbf{I} = \frac{10\angle 0^\circ}{1 + \frac{1}{2}(1+j)} = \frac{20}{\sqrt{10}} \angle -18.4^\circ \text{ A}$$

$$(a) P_{\text{source}} = \frac{|\mathbf{I}||\mathbf{V}|}{2} \cos \theta = \frac{(10)\left(\frac{20}{\sqrt{10}}\right)}{2} \cos(-18.4^\circ) = 30.0 \text{ W}$$

$$(b) P_{R_1} = \frac{I_{\text{max}}^2 R_1}{2} = \frac{\left(\frac{20}{\sqrt{10}}\right)^2 (1)}{2} = 20 \text{ W}$$

Ex. 11.4-1

$$I_{\text{eff}} = \sqrt{\frac{1}{T} \int_0^T i^2(t) dt} = \sqrt{\frac{1}{3} \left[\int_0^2 (10)^2 dt + \int_2^3 (5)^2 dt \right]} = \underline{8.66}$$

Ex. 11.4-2

$$(a) i(t) = 2 \cos 3t \text{ A} \Rightarrow I_{\text{eff}} \frac{I_{\text{max}}}{\sqrt{2}} = \frac{2}{\sqrt{2}} = \underline{\sqrt{2} \text{ A}}$$

$$(b) i(t) = \cos(3t - 90^\circ) + \cos(3t + 60^\circ) \text{ A}$$

$$\mathbf{I} = (1\angle -90^\circ) + (1\angle 60^\circ) = -j + \frac{1}{2} + j \frac{\sqrt{3}}{2} = 0.518\angle -15^\circ \text{ A}$$

$$i(t) = 0.518 \cos(3t - 15^\circ) \text{ A} \Rightarrow I_{\text{eff}} = \frac{0.518}{\sqrt{2}} = 0.366 \text{ A}$$

$$(c) I_{\text{eff}}^2 = \left(\frac{2}{\sqrt{2}}\right)^2 + \left(\frac{3}{\sqrt{2}}\right)^2 \Rightarrow I_{\text{eff}} = 2.55 \text{ A}$$

Ex. 11.4-3

Use superposition:

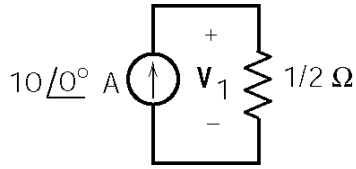

$$V_1 = 5\angle 0^\circ \text{ V}$$

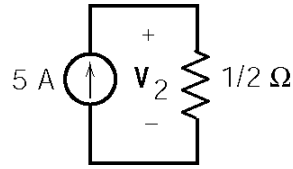

$$V_2 = 2.5 \text{ V (dc)}$$

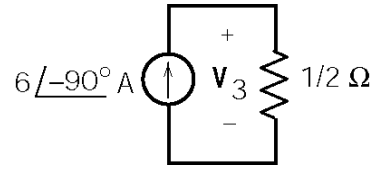

$$V_3 = 3\angle -90^\circ \text{ V}$$

V_1 and V_3 are phasors having the same frequency, so we can add them:

$$V_1 + V_3 = (5\angle 0^\circ) + (3\angle -90^\circ) = 5 - j3 = 5.83\angle -31.0^\circ \text{ V}$$

Then

$$v_R(t) = v_1(t) + (v_2(t) + v_3(t)) = 2.5 + 5.83 \cos(100t - 31.0^\circ) \text{ V}$$

Finally

$$V_{R,\text{eff}}^2 = (2.5)^2 + \left(\frac{5.83}{\sqrt{2}}\right)^2 = 23.24 \text{ V} \Rightarrow V_{R,\text{eff}} = 4.82 \text{ V}$$

Ex. 11.5-1

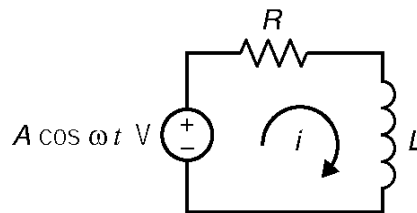

Analysis using Mathcad (ex11_5_1.mcd):

Enter the parameters of the voltage source: $A := 12$ $\omega := 2$

Enter the values of R and L $R := 10$ $L := 4$

The impedance seen by the voltage source is: $Z := R + j \cdot \omega \cdot L$

The mesh current is: $I := \frac{A}{Z}$

The complex power delivered by the source is: $S_v := \frac{\bar{I} \cdot (I \cdot Z)}{2}$ $S_v = 4.39 + 3.512i$

The complex power delivered to the resistor is: $S_r := \frac{\bar{I} \cdot (I \cdot R)}{2}$ $S_r = 4.39$

The complex power delivered to the inductor is: $S_l := \frac{\bar{I} \cdot (I \cdot j \cdot \omega \cdot L)}{2}$ $S_l = 3.512i$

Verify $S_v = S_r + S_l$: $S_r + S_l = 4.39 + 3.512i$ $S_v = 4.39 + 3.512i$

Ex. 11.5-2

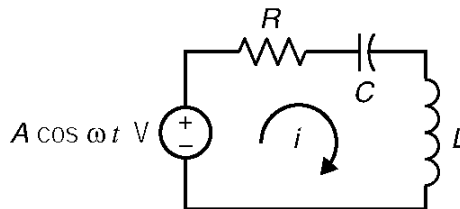

Analysis using Mathcad (ex11_5_2.mcd):

Enter the parameters of the voltage source: $A := 12$ $\omega := 2$

Enter the values of R, L and C $R := 10$ $L := 4$ $C := 0.1$

The impedance seen by the voltage source is: $Z := R + j \cdot \omega \cdot L + \frac{1}{j \cdot \omega \cdot C}$

The mesh current is: $I := \frac{A}{Z}$

The complex power delivered by the source is: $S_v := \frac{\bar{I} \cdot (I \cdot Z)}{2}$ $S_v = 6.606 + 1.982i$

The complex power delivered to the resistor is: $S_r := \frac{\bar{I} \cdot (I \cdot R)}{2}$ $S_r = 6.606$

The complex power delivered to the inductor is: $S_l := \frac{\bar{I} \cdot (I \cdot j \cdot \omega \cdot L)}{2}$ $S_l = 5.284i$

The complex power delivered to the capacitor is: $S_c := \frac{\bar{I} \cdot \left(I \cdot \frac{1}{j \cdot \omega \cdot C} \right)}{2}$ $S_c = -3.303i$

Verify $S_v = S_r + S_l + S_c$: $S_r + S_l + S_c = 6.606 + 1.982i$ $S_v = 6.606 + 1.982i$

Ex. 11.5-3

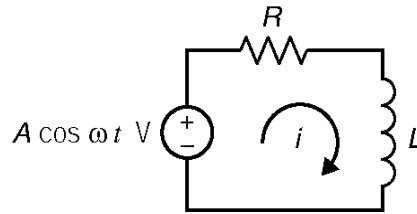

Analysis using Mathcad (ex11_5_3.mcd):

Enter the parameters of the voltage source: $A := 12$ $\omega := 2$

Enter the Average and Reactive Power delivered to the RL circuit: $P := 8$ $Q := 6$

The complex power delivered to the RL circuit is: $S := P + j \cdot Q$

The impedance seen by the voltage source is: $Z := \frac{A^2}{2 \cdot S}$

Calculate the required values of R and L $R := \text{Re}(Z)$ $L := \frac{\text{Im}(Z)}{\omega}$ $R = 5.76$ $L = 2.16$

The mesh current is: $I := \frac{A}{Z}$

The complex power delivered by the source is: $S_v := \frac{\bar{I} \cdot (I \cdot Z)}{2}$ $S_v = 8 + 6i$

The complex power delivered to the resistor is: $S_r := \frac{\bar{I} \cdot (I \cdot R)}{2}$ $S_r = 8$

The complex power delivered to the inductor is: $S_l := \frac{\bar{I} \cdot (I \cdot j \cdot \omega \cdot L)}{2}$ $S_l = 6i$

Verify $S_v = S_r + S_l$: $S_r + S_l = 8 + 6i$ $S_v = 8 + 6i$

Ex. 11.6-1

$$pf = \cos(\angle \mathbf{Z}) = \cos\left[\tan^{-1}\left(\frac{\omega L}{R}\right)\right] = \cos\left[\tan^{-1}\left(\frac{377(5)}{100}\right)\right] = \underline{0.053}$$

Ex. 11.6-2

$$pf = \cos(\angle \mathbf{Z}) = \cos\left[\tan^{-1}\left(\frac{X}{R}\right)\right] = \cos\left[\tan^{-1}\left(\frac{80}{50}\right)\right] = 0.53 \text{ lagging}$$

$$X_c = \frac{(50)^2 + (80)^2}{50 \tan(\cos^{-1} 1) - 80} = -111.25 \Omega \Rightarrow \mathbf{Z}_c = -j 111.25 \Omega$$

Ex. 11.6-3

$$P_T = 30 + 86 = 116 \text{ W and } Q_T = 51 \text{ VAR}$$

$$\mathbf{S}_T = P_T + j Q_T = 116 + j51 = 126.7 \angle 23.7^\circ \text{ VA}$$

$$pf_{\text{plant}} = \cos 23.7^\circ = 0.915$$

Ex. 11.6-4

$$P = VI \cos \theta \Rightarrow I = \frac{P}{V \cos \theta} = \frac{4000}{(110)(.82)} = 44.3 \text{ A}$$

$$\mathbf{Z} = \frac{V}{I} \angle \cos^{-1}(0.82) = 2.48 \angle 34.9^\circ = 2.03 + j1.42 = R + jX$$

To correct power factor to 0.95 requires

$$X_1 = \frac{R^2 + X^2}{R \tan(\cos^{-1} pfc) - X} = \frac{(2.03)^2 + (1.42)^2}{(2.03) \tan(18.19^\circ) - 1.42} = -8.16 \Omega$$

$$C = \frac{-1}{\omega X_1} = \underline{325 \mu\text{F}}$$

Ex. 11.7-1

$$(a) \mathbf{I} = \mathbf{I}_1 + \mathbf{I}_2 = (0.4714 \angle 135^\circ) + (1.414 \angle -45^\circ) = 0.9428 \angle -45^\circ \text{ A}$$

$$\Rightarrow p = \frac{0.9428^2}{2}(6) = 2.66 \text{ W}$$

$$(b) \mathbf{I}_1 = 1.2 \angle 53^\circ \text{ A} \Rightarrow p_1 = \frac{1.2^2}{2}(6) = 4.32 \text{ W}$$

$$\mathbf{I}_2 = 0.4714 \angle 135^\circ \text{ A} \Rightarrow p_2 = \frac{0.4714^2}{2}(6) = 0.666 \text{ W}$$

$$\therefore p = p_1 + p_2 = 4.99 \text{ W}$$

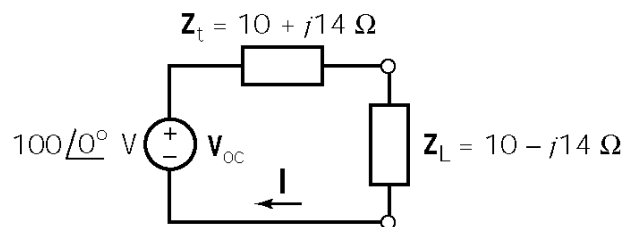
Ex. 11.8-1

For maximum power, transfer

$$\mathbf{Z}_L = \mathbf{Z}_t^* = 10 - j14 \Omega$$

$$\mathbf{I} = \frac{100}{(10 + j14)(10 - j14)} = 5 \text{ A}$$

$$P_L = \left(\frac{5}{\sqrt{2}} \right)^2 \text{Re}(10 - j14) = 125 \text{ W}$$

Ex. 11.8-2

If the station transmits a signal at 52 MHz then

$$\omega = 2\pi f = 104\pi \times 10^6 \text{ rad/sec}$$

so the received signal is

$$v_s(t) = 4 \cos(104\pi \times 10^6 t) \text{ mV}$$

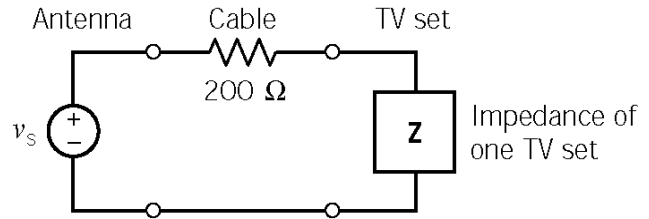

(a) If the receiver has an input impedance of $Z_{in} = 300 \Omega$ then

$$V_{in} = \frac{Z_{in}}{R + Z_{in}} V_s = \frac{300}{200 + 300} \times 4 \times 10^{-3} = 2.4 \text{ mV} \Rightarrow P = \frac{1}{2} V_{in}^2 \left(\frac{1}{R_L} \right) = \left(\frac{2.4 \times 10^{-3}}{2(300)} \right)^2 = \underline{9.6 \text{ nW}}$$

(b) If two receivers are connected in parallel then $Z_{in} = 300 \parallel 300 = 150 \Omega$ and

$$V_{in} = \frac{Z_{in}}{R + Z_{in}} V_s = \frac{150}{200 + 150} (4 \times 10^{-3}) = 1.71 \times 10^{-3} \text{ V}$$

$$\text{total } P = \frac{V_{in}^2}{2} \left(\frac{1}{Z_{in}} \right) = \frac{(1.71 \times 10^{-3})^2}{2(150)} = 9.7 \text{ nW or } 4.85 \text{ nW to each set}$$

(c) In this case, we need $Z_{in} = R \parallel R = 200 \Omega \Rightarrow R = 400 \Omega$, where R is the input impedance of each television receiver. Then

$$P_{\text{total}} = \frac{V_m^2}{2Z_{in}} = \frac{(2 \times 10^{-3})^2}{2(200)} = 10 \text{ nW} \Rightarrow 5 \text{ nW to each set}$$

Ex 11.9-1

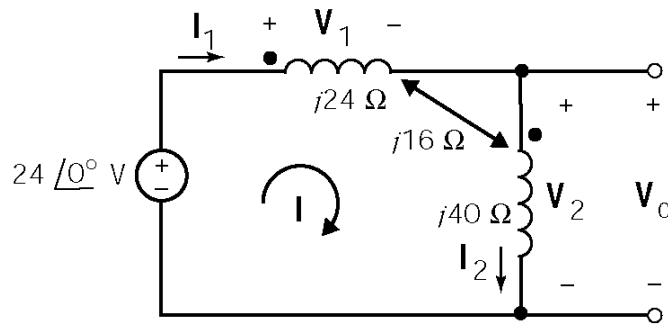

Coil voltages:

$$\mathbf{V}_1 = j24 \mathbf{I}_1 + j16 \mathbf{I}_2 = j40 \mathbf{I}$$

$$\mathbf{V}_2 = j16 \mathbf{I}_1 + j40 \mathbf{I}_2 = j56 \mathbf{I}$$

Mesh equation:

$$24 = \mathbf{V}_1 + \mathbf{V}_2 = j40 \mathbf{I} + j56 \mathbf{I} = j96 \mathbf{I}$$

$$\mathbf{I} = \frac{24}{j96} = -j\frac{1}{4}$$

$$\mathbf{V}_o = \mathbf{V}_2 = (j56) \left(-j\frac{1}{4} \right) = 14$$

$$v_o = 14 \cos 4t \text{ V}$$

Ex 11.9-2

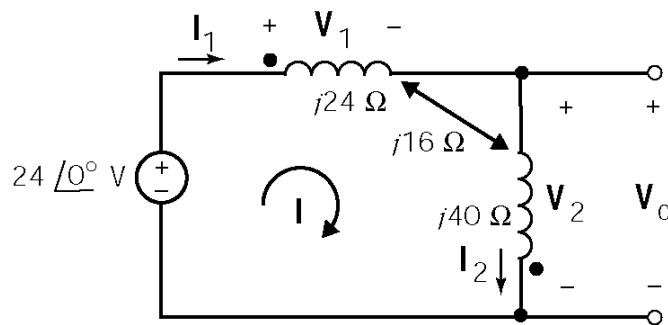

Coil voltages:

$$\mathbf{V}_1 = j24 \mathbf{I}_1 - j16 \mathbf{I}_2 = j8 \mathbf{I}$$

$$\mathbf{V}_2 = -j16 \mathbf{I}_1 + j40 \mathbf{I}_2 = j24 \mathbf{I}$$

Mesh equation:

$$24 = \mathbf{V}_1 + \mathbf{V}_2 = j8 \mathbf{I} + j24 \mathbf{I} = j32 \mathbf{I}$$

$$\mathbf{I} = \frac{24}{j32} = -j\frac{3}{4}$$

$$\mathbf{V}_o = \mathbf{V}_2 = (j24) \left(-j\frac{3}{4} \right) = 18$$

$$v_o = 18 \cos 4t \text{ V}$$

Ex 11.9-3

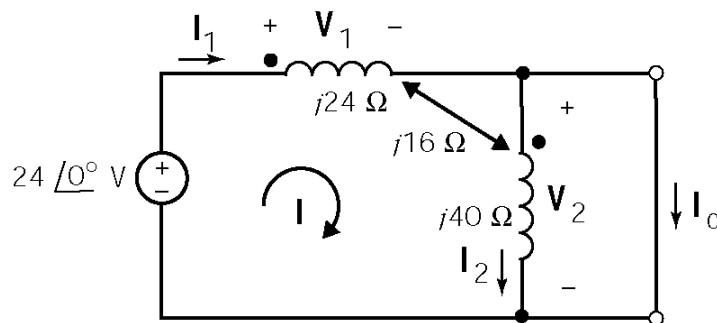

$$0 = \mathbf{V}_2 = j16 \mathbf{I}_1 + j40 \mathbf{I}_2$$

$$\Rightarrow \mathbf{I}_1 = -\frac{40}{16} \mathbf{I}_2 = -2.5 \mathbf{I}_2$$

$$\begin{aligned} \mathbf{V}_s = \mathbf{V}_1 &= j24 \mathbf{I}_1 + j16 \mathbf{I}_2 \\ &= j(24(-2.5) + 16) \mathbf{I}_2 \\ &= -j44 \mathbf{I}_2 \end{aligned}$$

$$\mathbf{I}_2 = \frac{24}{-j44} = j\frac{6}{11}$$

$$\begin{aligned} \mathbf{I}_o = \mathbf{I}_1 - \mathbf{I}_2 &= (-2.5 - 1) \mathbf{I}_2 \\ &= -3.5 \mathbf{I}_2 \end{aligned}$$

$$= -3.5 \left(j\frac{6}{11} \right) = -j1.909$$

$$i_o = 1.909 \cos (4t - 90^\circ) \text{ A}$$

Ex 11.9-4

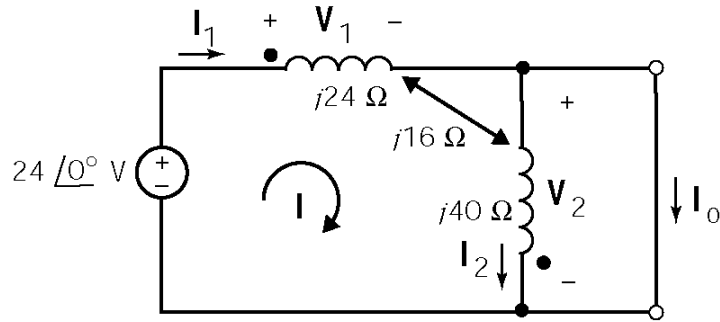

$$\begin{aligned}
 0 &= V_2 = -j16 I_1 + j40 I_2 \\
 \Rightarrow I_1 &= \frac{40}{16} I_2 = 2.5 I_2 \\
 V_s = V_1 &= j24 I_1 - j16 I_2 \\
 &= j(24(2.5) - 16) I_2 \\
 &= j44 I_2 \\
 I_2 &= \frac{24}{j44} = -j \frac{6}{11} \\
 I_o = I_1 - I_2 &= (2.5 - 1) I_2 \\
 &= 1.5 I_2 \\
 &= 1.5 \left(-j \frac{6}{11} \right) = -j 0.818 \\
 i_o &= 0.818 \cos(4t - 90^\circ) \text{ A}
 \end{aligned}$$

Ex. 11.10-1

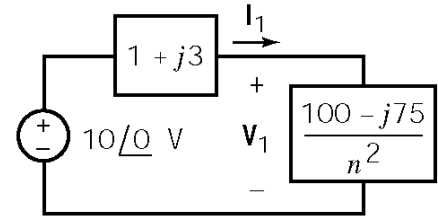
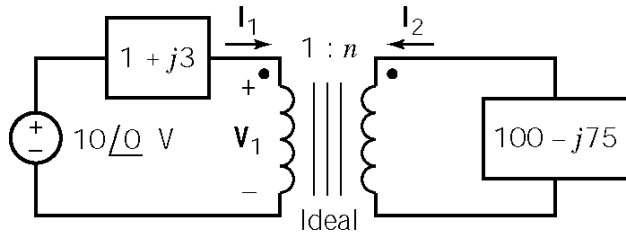

$$I_1 = \frac{5 \angle 0^\circ}{(1 + j3) + \frac{100 - j75}{5^2}} = \frac{5 \angle 0^\circ}{(1 + j3) + (4 - j3)} = 2 \angle 0^\circ \text{ A}$$

$$V_1 = (4 - j3) 2 \angle 0^\circ = 10 \angle -36.9^\circ \text{ V}$$

Ex. 11.10-2

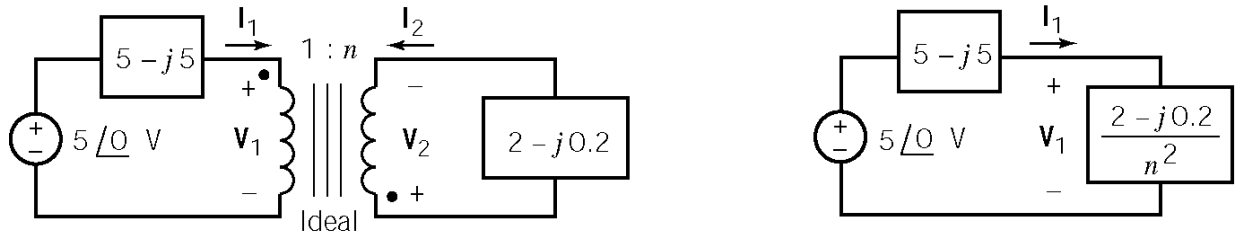

$$\mathbf{I}_1 = \frac{5\angle 0^\circ}{(5-j5) + \frac{2+j0.2}{2^2}} = \frac{5\angle 0^\circ}{5.5+j4.95} = \frac{5\angle 0^\circ}{7.4\angle -42^\circ} = 0.68\angle 42^\circ \text{ A}$$

$$\mathbf{I}_2 = \frac{1}{2}\mathbf{I}_1 = 0.34\angle 42^\circ \text{ A}$$

$$\mathbf{V}_2 = (2+j0.2)\mathbf{I}_2 = (2.01\angle 5.7^\circ)(0.34\angle 42^\circ) = 0.68\angle 47.7^\circ \text{ V}$$

so

$$v_2(t) = 0.68 \cos(10t + 47.7^\circ) \text{ V and } i_2(t) = 0.34 \cos(10t + 42^\circ) \text{ A}$$

Ex. 11.10-3

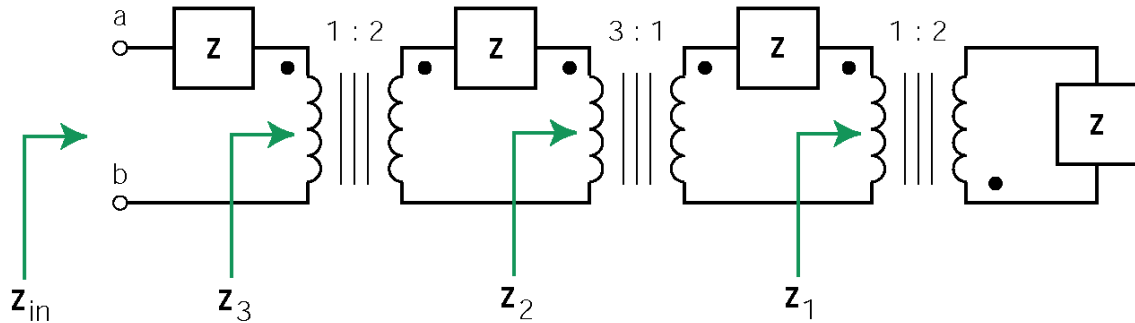

$$\mathbf{Z}_1 = \frac{\mathbf{Z}}{n_3^2} = \frac{\mathbf{Z}}{4}, \quad \mathbf{Z}_2 = \frac{1}{n_2^2} \left(\mathbf{Z} + \frac{\mathbf{Z}}{n_3^2} \right) = 9 \left(\mathbf{Z} + \frac{\mathbf{Z}}{4} \right) \quad \text{and} \quad \mathbf{Z}_3 = \frac{1}{n_1^2} (\mathbf{Z} + \mathbf{Z}_2)$$

then

$$\mathbf{Z}_{ab} = \mathbf{Z}_{in} = \mathbf{Z} + \mathbf{Z}_3 = \mathbf{Z} + \frac{1}{4} \left(\mathbf{Z} + 9 \left(\mathbf{Z} + \frac{\mathbf{Z}}{4} \right) \right) = 4.0625 \mathbf{Z}$$

Problems

Section 11-3: Instantaneous Power and Average Power

P11.3-1

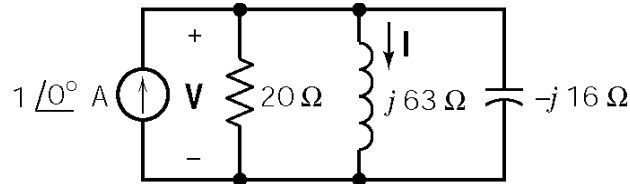

$$1\angle 0^\circ = \frac{\mathbf{V}}{20} + \frac{\mathbf{V}}{j63} + \frac{\mathbf{V}}{-j16} \Rightarrow \mathbf{V} = 14.6\angle -43^\circ \text{ V}$$

$$\mathbf{I} = \frac{\mathbf{V}}{j63} = 0.23\angle -133^\circ \text{ A}$$

$$\begin{aligned} p(t) &= i(t)v(t) = 0.23(\cos(2\pi \cdot 10^3 t - 133^\circ)) \times 14.6 \cos(2\pi \cdot 10^3 t - 43^\circ) \\ &= 3.36 \cos(2\pi \cdot 10^3 t - 133^\circ) \cos(2\pi \cdot 10^3 t - 43^\circ) \\ &= 1.68 (\cos(90^\circ) + \cos(4\pi \cdot 10^3 t - 176^\circ)) \\ &= 1.68 \cos(4\pi \cdot 10^3 t - 176^\circ) \end{aligned}$$

P11.3-2

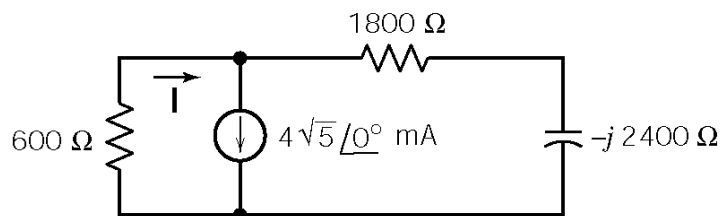

Current division:

$$\begin{aligned} \mathbf{I} &= 4\sqrt{5} \left[\frac{1800 - j2400}{1800 - j2400 + 600} \right] \\ &= 5\sqrt{\frac{5}{2}} \angle -8.1^\circ \text{ mA} \end{aligned}$$

$$P_{600\Omega} = \frac{|\mathbf{I}|^2 600}{2} = 300(25) \left(\frac{5}{2} \right) = 1.875 \times 10^4 \mu\text{W} = 18.75 \text{ mW}$$

$$P_{\text{source}} = \frac{|\mathbf{V}||\mathbf{I}|\cos\theta}{2} = \frac{1}{2}(600) \left(5\sqrt{\frac{5}{2}} \right) (4\sqrt{5}) \cos(-8.1^\circ) = 2.1 \times 10^4 \mu\text{W} = 21 \text{ mW}$$

P11.3-3

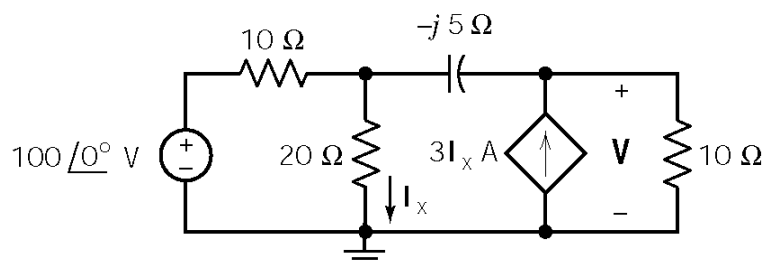

Node equations:

$$\frac{20\mathbf{I}_x - 100}{10} + \mathbf{I}_x + \frac{20\mathbf{I}_x - \mathbf{V}}{-j5} = 0 \Rightarrow \mathbf{I}_x(20 - j15) - \mathbf{V} = -j50$$

$$\frac{\mathbf{V} - 20\mathbf{I}_x}{-j5} - 3\mathbf{I}_x + \frac{\mathbf{V}}{10} = 0 \Rightarrow \mathbf{I}_x(-40 + j30) + \mathbf{V}(-2 - j) = 0$$

Solving the node equations using Cramer's rule yields

$$\mathbf{I}_x = \frac{j50(2 - j)}{(40 - j30) - (20 - j15)(2 - j)} = \frac{50\sqrt{5}\angle 63.4^\circ}{25\angle 53.1^\circ} = 2\sqrt{5}\angle 10.3^\circ \text{ A}$$

Then

$$P_{\text{AVE}} = \frac{|\mathbf{I}_x|^2}{2}(20) = 10(2\sqrt{5})^2 = 200 \text{ W}$$

P11.3-4

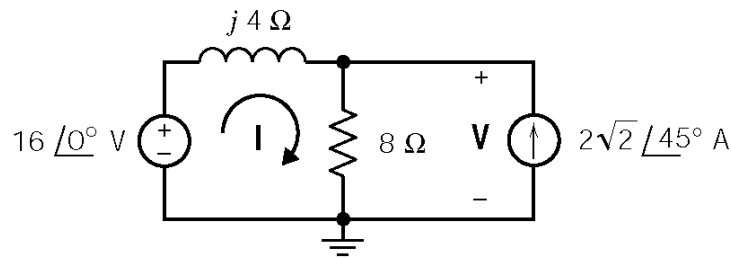

A node equation:

$$\frac{(\mathbf{V} - 16)}{j4} + \frac{\mathbf{V}}{8} - (2\sqrt{2}\angle 45^\circ) = 0$$

$$\Rightarrow \mathbf{V} = \left(16\sqrt{\frac{2}{3}}\right)\angle 18.4^\circ \text{ V}$$

Then

$$\mathbf{I} = \frac{16 - \mathbf{V}}{j4} = \sqrt{3.2}\angle -116.6^\circ \text{ A}$$

$$P_{\text{AVE } 8\Omega} = \frac{1}{2} \times \frac{|\mathbf{V}|^2}{8} = \frac{1}{2} \times \frac{\left(16\sqrt{\frac{2}{5}}\right)^2}{8} = 6.4 \text{ W absorbed}$$

$$P_{\text{AVE current source}} = -\frac{1}{2} |\mathbf{V}| (2\sqrt{2}) \cos \theta = -\frac{1}{2} \left(16\sqrt{\frac{2}{5}}\right) (2\sqrt{2}) \cos(26.6^\circ) = -12.8 \text{ W absorbed}$$

$$P_{\text{AVE inductor}} = 0$$

$$P_{\text{AVE voltage source}} = -\frac{1}{2} (16) |\mathbf{I}| \cos \theta = -\frac{1}{2} (16) (\sqrt{3.2}) \cos(-116.6^\circ) = 6.4 \text{ W absorbed}$$

P11.3-6

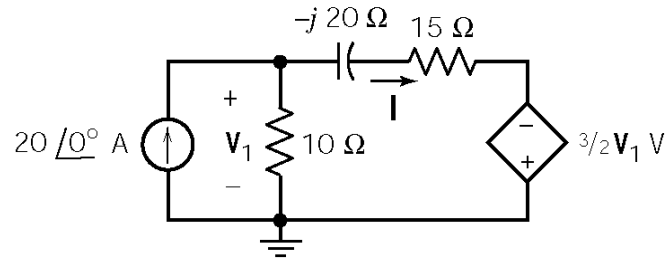

A node equation:

$$-20 + \frac{V_1}{10} + \frac{V_1 + (3/2)V_1}{15 - j20} = 0 \Rightarrow V_1 = 50\sqrt{5} \angle -26.6^\circ \text{ V}$$

Then

$$\mathbf{I} = \frac{V_1 + (3/2)V_1}{15 - j20} = \frac{(5/2)V_1}{25 \angle -53.1^\circ} = 5\sqrt{5} \angle 26.6^\circ \text{ A}$$

Now the various powers can be calculated:

$$P_{\text{AVE } 10\Omega} = \frac{1}{2} \frac{|V_1|^2}{10} = \frac{1}{2} \frac{(50\sqrt{5})^2}{10} = 625 \text{ W absorbed}$$

$$P_{\text{AVE current source}} = -\frac{1}{2} |\mathbf{V}| (20) \cos \theta = -\frac{1}{2} (50\sqrt{5})(20) \cos(-26.6^\circ) = -1000 \text{ W absorbed}$$

$$P_{\text{AVE } 15\Omega} = \frac{|\mathbf{I}|^2}{2} (15) = -\frac{(5\sqrt{5})^2}{2} (15) = 937.5 \text{ W absorbed}$$

$$P_{\text{AVE voltage source}} = -\frac{1}{2} |\mathbf{I}| \left| \frac{3}{2} V_1 \right| \cos \theta = -\frac{1}{2} (5\sqrt{5}) (75\sqrt{5}) \cos(-53.1^\circ) = -562.5 \text{ W absorbed}$$

$$P_{\text{AVE capacitor}} = 0 \text{ W}$$

P11.3-7

$$\mathbf{Z} = \frac{200(j200)}{200(1+j)} = \frac{200 \angle 90^\circ}{\sqrt{2} \angle 45^\circ} = \frac{200}{\sqrt{2}} \angle 45^\circ \Omega$$

$$\mathbf{I} = \frac{120 \angle 0^\circ}{\frac{200}{\sqrt{2}} \angle 45^\circ} = 0.85 \angle -45^\circ \text{ A}, \quad \mathbf{I}_R = \left(\frac{200}{200 + j200} \right) \mathbf{I} = 0.6 \angle 0^\circ \text{ A}$$

$$P = |\mathbf{I}|^2 R = (0.6)^2 (200) = 72 \text{ W and } w = (72)(1) = 72 \text{ J}$$

Section 11-4: Effective Value of a Periodic Waveform

P11.4-1

- (a) $i = 2 - 4 \cos 2t = i_1 + i_2$ (Treat i as two sources of different frequencies.)

$$2A \text{ source: } I_{\text{eff}} = \lim_{T \rightarrow \infty} \sqrt{\frac{1}{T} \int_0^T (2)^2 dt} = 2 \text{ A}$$

and

$$4 \cos 2t \text{ source: } I_{\text{eff}} = \frac{4}{\sqrt{2}} \text{ A}$$

The total is calculated as

$$I_{\text{eff}}^2 = (2)^2 + \left(\frac{4}{\sqrt{2}}\right)^2 = 12 \text{ A} \Rightarrow I_{\text{rms}} = I_{\text{eff}} = \sqrt{12} = 2\sqrt{3} \text{ A}$$

- (b) $i(t) = 3 \cos(\pi t - 90^\circ) + \sqrt{2} \cos \pi t \Rightarrow \mathbf{I} = (3 \angle -90^\circ) + (\sqrt{2} \angle 0^\circ)$
 $= \sqrt{2} - j3 = 3.32 \angle -64.8^\circ \text{ A}$

$$I_{\text{rms}} = \frac{3.32}{\sqrt{2}} = 2.35 \text{ A}$$

- (c) $i(t) = 2 \cos 2t + 4\sqrt{2} \cos(2t + 45^\circ) + 12 \cos(2t - 90^\circ)$

$$\mathbf{I} = (2 \angle 0^\circ) + (4\sqrt{2} \angle 45^\circ) + (12 \angle -90^\circ) = (2 + 4) + (j4 - j12) = 10 \angle -53.1^\circ \text{ A}$$

$$I_{\text{rms}} = \frac{10}{\sqrt{2}} = 5\sqrt{2} \text{ A}$$

P11.4-2

(a) $V_{\text{rms}} = \sqrt{\frac{1}{5} \left(\int_0^2 6^2 dt + \int_2^5 2^2 dt \right)} = \sqrt{\frac{1}{5} \left(\int_0^2 36 dt + \int_2^5 4 dt \right)} = \sqrt{\frac{1}{5} (72 + 12)} = \sqrt{\frac{84}{5}} = 4.10 \text{ V}$

(b) $V_{\text{rms}} = \sqrt{\frac{1}{5} \left(\int_0^2 2^2 dt + \int_2^5 6^2 dt \right)} = \sqrt{\frac{1}{5} \left(\int_0^2 4 dt + \int_2^5 36 dt \right)} = \sqrt{\frac{1}{5} (8 + 108)} = \sqrt{\frac{116}{5}} = 4.81 \text{ V}$

(c) $V_{\text{rms}} = \sqrt{\frac{1}{5} \left(\int_0^3 2^2 dt + \int_3^5 6^2 dt \right)} = \sqrt{\frac{1}{5} \left(\int_0^3 4 dt + \int_3^5 36 dt \right)} = \sqrt{\frac{1}{5} (12 + 72)} = \sqrt{\frac{84}{5}} = 4.10 \text{ V}$

P11.4-3

$$\begin{aligned}
 \text{(a)} \quad V_{\text{rms}} &= \sqrt{\frac{1}{3} \int_1^4 \left(\frac{4}{3}t + \frac{2}{3} \right)^2 dt} = \sqrt{\frac{4}{27} \int_1^4 (2t+1)^2 dt} = \sqrt{\frac{4}{27} \int_1^4 (4t^2 + 4t + 1) dt} \\
 &= \sqrt{\frac{4}{27} \left(\frac{4t^3}{3} \Big|_1^4 + \frac{4t^2}{2} \Big|_1^4 + t \Big|_1^4 \right)} \\
 &= \sqrt{\frac{4}{27} ((85.33 - 1.33) + (2)(16 - 1) + 3)} \\
 &= \sqrt{\frac{4}{27}(117)} = 4.16 \text{ V}
 \end{aligned}$$

$$\begin{aligned}
 \text{(b)} \quad V_{\text{rms}} &= \sqrt{\frac{1}{3} \int_1^4 \left(-\frac{4}{3}t + \frac{22}{3} \right)^2 dt} = \sqrt{\frac{4}{27} \int_1^4 (-2t+11)^2 dt} = \sqrt{\frac{4}{27} \int_1^4 (4t^2 - 44t + 121) dt} \\
 &= \sqrt{\frac{4}{27} \left(\frac{4t^3}{3} \Big|_1^4 - \frac{44t^2}{2} \Big|_1^4 + 121t \Big|_1^4 \right)} \\
 &= \sqrt{\frac{4}{27} (84 + (-22)15 + (121)3)} \\
 &= \sqrt{\frac{4}{27}(117)} = 4.16 \text{ V}
 \end{aligned}$$

$$\begin{aligned}
 \text{(c)} \quad V_{\text{rms}} &= \sqrt{\frac{1}{3} \int_0^3 \left(\frac{4}{3}t + 2 \right)^2 dt} = \sqrt{\frac{4}{27} \int_0^3 (2t+3)^2 dt} = \sqrt{\frac{4}{27} \int_0^3 (4t^2 + 12t + 9) dt} \\
 &= \sqrt{\frac{4}{27} \left(\frac{4t^3}{3} \Big|_0^3 + \frac{12t^2}{2} \Big|_0^3 + 9t \Big|_0^3 \right)} \\
 &= \sqrt{\frac{4}{27} (36 + 54 + 27)} \\
 &= \sqrt{\frac{4}{27}(117)} = 4.16 \text{ V}
 \end{aligned}$$

P11.4-4

(a)

$$v(t) = 1 + \cos\left(\frac{2\pi}{T}t\right) = v_{\text{dc}} + v_{\text{ac}}$$

$$v_{\text{dc eff}}^2 = \left(\frac{1}{T} \int_0^T 1 dt\right) = \frac{t}{T} \Big|_0^T = \left(\frac{T}{T} - 0\right) = 1 \text{ V} \quad \text{and} \quad v_{\text{ac eff}}^2 = \frac{1}{\sqrt{2}} \text{ V}$$

$$v_{\text{eff}}^2 = v_{\text{dc eff}}^2 + v_{\text{ac eff}}^2 = \sqrt{1^2 + \left(\frac{1}{\sqrt{2}}\right)^2} = 1.225 \text{ V}$$

(b)

$$\omega = \frac{2\pi}{T}, \quad I_{\text{rms}} = \sqrt{\frac{1}{T} \int_0^T i^2(t) dt}$$

$$I_{\text{rms}}^2 = \frac{1}{T} \int_0^{T/2} (A \sin \omega t)^2 dt = \frac{A^2}{T} \int_0^{T/2} \frac{1}{2} (1 - \cos 2\omega t) dt = \frac{A^2}{2T} \left[\int_0^{T/2} dt - \int_0^{T/2} \cos 2\omega t dt \right] = \frac{A^2}{4} \text{ A}$$

$$I_{\text{rms}} = \sqrt{\frac{A^2}{4}} = \frac{A}{2}, \quad \text{where } A = 10 \text{ mA} \Rightarrow I_{\text{rms}} = 5 \text{ mA}$$

P11.4-5

$$v(t) = \begin{cases} 90t & 0 \leq t \leq 0.1 \\ 90(0.2-t) & 0.1 \leq t \leq 0.2 \\ 0 & 0.2 \leq t \leq 0.3 \end{cases}$$

$$\begin{aligned} V_{\text{rms}}^2 &= \frac{1}{.3} \left[\int_0^{0.1} (90t)^2 dt + \int_{0.1}^{0.2} [90(0.2-t)]^2 dt \right] = \frac{90^2}{.3} \left[\int_0^{0.1} t^2 dt + \int_{0.1}^{0.2} (0.2-t)^2 dt \right] \\ &= \frac{90^2}{.3} \left[\frac{.001}{3} + \frac{.001}{3} \right] = 18 \text{ V} \end{aligned}$$

$$V_{\text{rms}} = \sqrt{18} = 4.24 \text{ V}$$

Section 11-5: Complex Power

P11.5-1

$$\mathbf{I}^* = \frac{2 \text{ S}}{12 \angle 0^\circ} = \frac{2(3.6 + j7.2)}{12 \angle 0^\circ} = 0.6 + j1.2 = 1.342 \angle 63.43^\circ \text{ A}$$

$$R + j4L = \frac{12 \angle 0^\circ}{1.342 \angle -63.43} = 8.94 \angle 63.43 = 4 + j8 \Rightarrow R = 4 \ \Omega \text{ and } L = 2 \text{ H}$$

P 11.5-2

$$\mathbf{I}^* = \frac{2 \text{ S}}{12 \angle 0^\circ} = \frac{2(18 + j9)}{12 \angle 0^\circ} = 3 + j1.5 = 3.35 \angle 26.56^\circ \text{ A}$$

$$\frac{1}{R} + \frac{1}{j4L} = \frac{1}{R} - j\frac{1}{4L} = \frac{3.35 \angle -26.56^\circ}{12 \angle 0^\circ} = 0.2791 \angle -26.56 = 0.250 + j0.125$$

$$\Rightarrow R = 4 \ \Omega \text{ and } L = 2 \text{ H}$$

P11.5-3

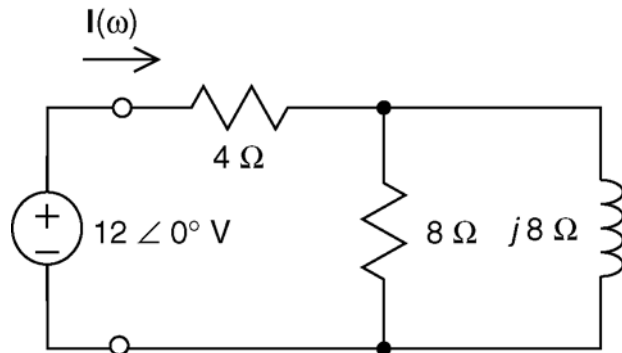

Let

$$\mathbf{Z}_p = \frac{8(j8)}{8 + j8} = \frac{j8}{1 + j} \times \frac{1 - j}{1 - j} = \frac{8 + j8}{2} = 4 + j4 \ \Omega$$

Next

$$\mathbf{I} = \frac{12 \angle 0^\circ}{4 + \mathbf{Z}_p} = \frac{12 \angle 0^\circ}{4 + (8 + j8)} = 1.342 \angle -26.6^\circ \text{ A}$$

Finally

$$\mathbf{S} = \frac{(12 \angle 0^\circ)(1.342 \angle -26.6^\circ)^*}{2} = 7.2 + j3.6 \text{ VA}$$

P11.5-4

Before writing node equations, we can simplify the circuit using a source transformation:

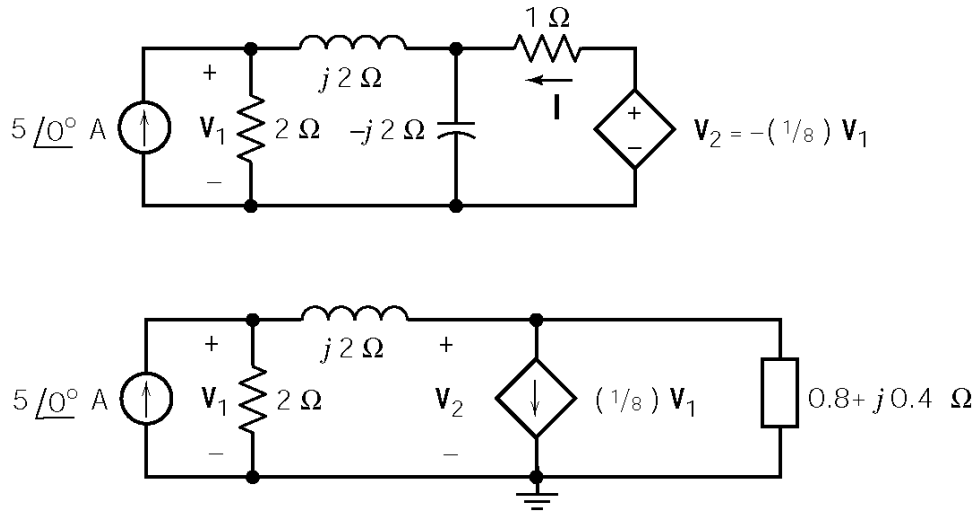

The node equations are:

$$-5 + \frac{V_1}{2} + \frac{V_1 - V_2}{j2} = 0 \Rightarrow V_1(1 + j) - V_2 = 10$$

$$\frac{V_2 - V_1}{j2} + \frac{1}{8}V_1 + \frac{V_2}{0.8 + j0.4} = 0 \Rightarrow V_1(-4 + j) + V_2(j8) = 0$$

Using Cramer's rule

$$V_1 = \frac{80}{(4 - j) - j8(1 + j)} = (16/3) \angle 126.9^\circ \text{ V}$$

then

$$I = -\frac{1}{8}V_1 - V_2 = -\frac{1}{8}V_1 - V_1(1 + j) + j10 = 2.66 \angle 126.9^\circ \text{ A}$$

Now the complex power can be calculated as

$$S = \frac{I^* (-1/8)V_1}{2} = \frac{(2.66 \angle -126.9^\circ) \left(-(2/3) \angle 36.9^\circ \right)}{2} = -j \frac{8}{9} \text{ VA}$$

Finally

$$S = P + jQ = j \frac{8}{9} \Rightarrow P = 0, Q = \frac{8}{9} \text{ VAR}$$

P11.5-5

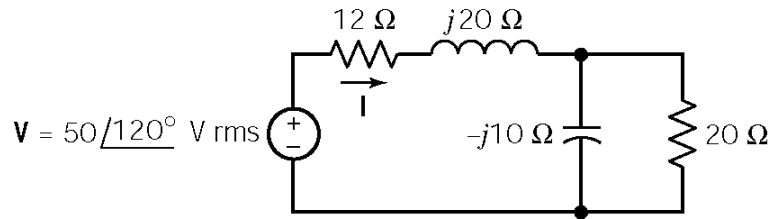

$$\mathbf{I} = \frac{50\angle 120^\circ}{16 + j12} = \frac{50\angle 120^\circ}{20\angle 36.87^\circ} = 2.5\angle 83.13^\circ \text{ A}$$

$$\mathbf{S} = \mathbf{V}\mathbf{I}^* = (50\angle 120^\circ)(2.5\angle -83.13^\circ) = 125\angle 36.87^\circ = 100 + j75 \text{ VA}$$

P11.5-6

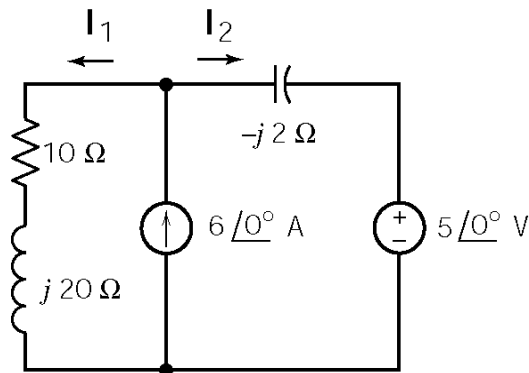

KVL:

$$(10 + j20)\mathbf{I}_1 = 5\angle 0^\circ - j2\mathbf{I}_2$$

$$\Rightarrow (10 + j20)\mathbf{I}_1 + j2\mathbf{I}_2 = 5\angle 0^\circ$$

KCL:

$$\mathbf{I}_1 + \mathbf{I}_2 = 6\angle 0^\circ$$

Solving these equations using Cramer's rule:

$$\Delta = \begin{vmatrix} 10 + j20 & j2 \\ 1 & 1 \end{vmatrix} = 10 + j18$$

$$\mathbf{I}_1 = \frac{1}{\Delta} \begin{vmatrix} 5 & j2 \\ 6 & 1 \end{vmatrix} = \frac{5 - j12}{10 + j18} = 0.63\angle 232^\circ \text{ A} = -0.39 - j0.5 \text{ A}$$

$$\mathbf{I}_2 = 6 - \mathbf{I}_1 = 6 + 0.39 + j0.5 = 6.39 + j0.5 = 6.41\angle 4.47^\circ \text{ A}$$

Now we are ready to calculate the powers. First, the powers delivered:

$$\mathbf{S}_{5\angle 0^\circ} = \frac{1}{2}(5\angle 0^\circ)(-\mathbf{I}_2^*) = 2.5(6.41\angle (180 - 4.47)) = -16.0 + j1.1 \text{ VA}$$

$$\mathbf{S}_{6\angle 0^\circ} = \frac{1}{2}[5 - j2\mathbf{I}_2](6\angle 0^\circ) = [5 - j2(6.39 + j0.5)]3 = 18.0 - j38.3 \text{ VA}$$

$$\mathbf{S}_{\text{Total delivered}} = \mathbf{S}_{5\angle 0^\circ} + \mathbf{S}_{6\angle 0^\circ} = \underline{2.0 - j37.2 \text{ VA}}$$

Next, the powers absorbed:

$$S_{10\Omega} = \frac{1}{2} 10 |\mathbf{I}_1|^2 = \frac{10}{2} (.63)^2 = 2.0 \text{ VA}$$

$$S_{j20\Omega} = \frac{j20}{2} |\mathbf{I}_1|^2 = j4.0 \text{ VA}$$

$$S_{-j2\Omega} = \frac{1}{2} (-j2) |\mathbf{I}_2|^2 = -j (6.41)^2 = -j41.1 \text{ VA}$$

$$S_{\text{Total absorbed}} = \underline{2.0 - j37.1 \text{ VA}}$$

To our numerical accuracy, the total complex power delivered is equal to the total complex power absorbed.

P11.5-7

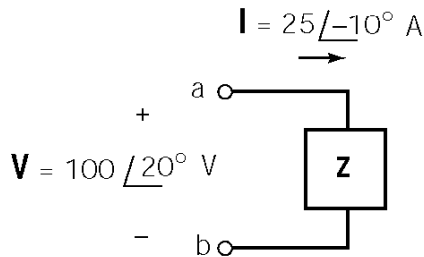

(a) $Z = \frac{\mathbf{V}}{\mathbf{I}} = \frac{100\angle 20^\circ}{25\angle -10^\circ} = 4\angle 30^\circ \Omega$

(b) $P = \frac{|\mathbf{I}||\mathbf{V}|\cos\theta}{2} = \frac{(100)(25)\cos 30^\circ}{2} = 1082.5 \text{ W}$

(c) $\mathbf{Y} = \frac{1}{\mathbf{Z}} = 0.25\angle -30^\circ = 0.2165 - j0.125 \text{ S}$. To cancel the phase angle we add a capacitor having an admittance of $\mathbf{Y}_C = j0.125 \text{ S}$. That requires $\omega C = 0.125 \Rightarrow C = 1.25 \text{ mF}$.

P11.5-8

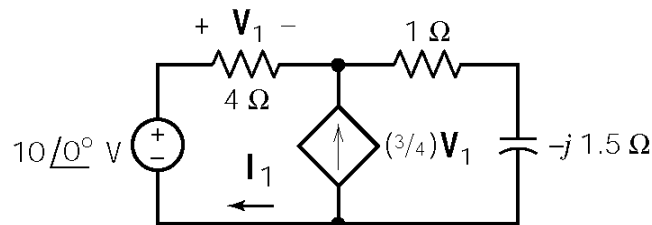

Apply KCL at the top node to get

$$-\frac{\mathbf{V}_1}{3} - \frac{3}{4}\mathbf{V}_1 + \frac{10 - \mathbf{V}_1}{1 - j\frac{3}{2}} = 0 \Rightarrow \mathbf{V}_1 = 4\angle 36.9^\circ \text{ V}$$

Then

$$\mathbf{I}_1 = \frac{\mathbf{V}_1}{4} = 1\angle 36.9^\circ \text{ A}$$

The complex power delivered by the source is calculated as

$$\mathbf{S} = \frac{(1\angle 36.9^\circ)^* (10\angle 0^\circ)}{2} = 5\angle -36.9^\circ \text{ VA}$$

Finally

$$pf = \cos(-36.9^\circ) = .8 \text{ leading}$$

Section 11.6: Power Factor

P11.6-1

Heating: $P = 30 \text{ kW}$

Motor:
$$\left. \begin{array}{l} \theta = \cos^{-1}(0.6) = 53.1^\circ \\ |\mathbf{S}| = 150 \text{ kVA} \end{array} \right\} \Rightarrow \left\{ \begin{array}{l} P = 150 \cos 53.1^\circ = 90 \text{ kW} \\ Q = 150 \sin 53.1^\circ = 120 \text{ kVAR} \end{array} \right.$$

Total (plant):
$$\left. \begin{array}{l} P = 30 + 90 = 120 \text{ kW} \\ Q = 0 + 120 = 120 \text{ kVAR} \end{array} \right\} \Rightarrow \mathbf{S} = 120 + j120 = 170 \angle 45^\circ \text{ VA}$$

The power factor is $pf = \cos 45^\circ = 0.707$ lagging.

The current required by the plant is $|\mathbf{I}| = \frac{|\mathbf{S}|}{|\mathbf{V}|} = \frac{170 \text{ kVA}}{4 \text{ kV}} = 42.5 \text{ A}.$

P11.6-2

Load 1: $P_1 = |\mathbf{S}| \cos \theta = (12 \text{ kVA})(0.7) = 8.4 \text{ kW}$

$$Q_1 = |\mathbf{S}| \sin(\cos^{-1}(0.7)) = (12 \text{ kVA}) \sin(45.6^\circ) = 8.57 \text{ kVAR}$$

Load 2: $P_2 = (10 \text{ kVA})(0.8) = 8 \text{ kW}$

$$Q_2 = 10 \sin(\cos^{-1}(0.8)) = 10 \sin(36.9^\circ) = 6.0 \text{ kVAR}$$

Total: $\mathbf{S} = P + jQ = 8.4 + 8 + j(8.57 + 6.0) = 16.4 + j14.57 = 21.9 \angle 41.6^\circ \text{ kVA}$

The power factor is $pf = \cos(41.6^\circ) = 0.75$. The average power is $P = 16.4 \text{ kW}$. The apparent power is $|\mathbf{S}| = 21.9 \text{ kVA}$.

P11.6-3

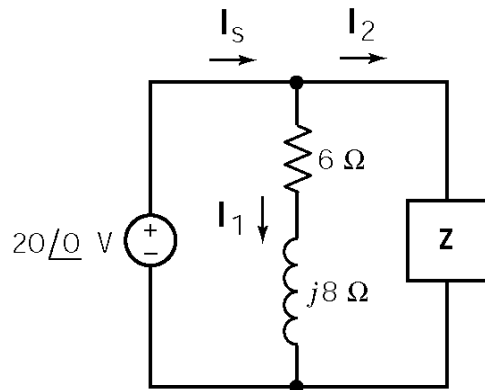

The source current can be calculated from the apparent power:

$$\mathbf{S} = \frac{\mathbf{V}_s \mathbf{I}_s^*}{2} \Rightarrow \mathbf{I}_s^* = \frac{2\mathbf{S}}{\mathbf{V}_s} = \frac{2(50 \angle \cos^{-1} 0.8)}{20 \angle 0^\circ} = 5 \angle 36.9^\circ \text{ A}$$

$$\mathbf{I}_s = 5 \angle -36.9^\circ = 4 - j3 \text{ A}$$

Next

$$\mathbf{I}_1 = \frac{\mathbf{V}_s}{6 + j8} = \frac{20 \angle 0^\circ}{10 \angle 53.1^\circ} = 2 \angle -53.1^\circ = 1.2 - j1.6 \text{ A}$$

$$\begin{aligned} \mathbf{I}_2 = \mathbf{I}_s - \mathbf{I}_1 &= 4 - j3 - 1.2 + j1.6 = 2.8 - j1.4 \\ &= 3.13 \angle -26.6^\circ \text{ A} \end{aligned}$$

Finally,

$$\mathbf{Z} = \frac{\mathbf{V}_s}{\mathbf{I}_2} = \frac{20 \angle 0^\circ}{3.13 \angle -26.6^\circ} = 6.39 \angle 26.6^\circ \Omega$$

P11.6-4

(Using all rms values.)

(a) $P = |\mathbf{I}|^2 R = \frac{|\mathbf{V}|^2}{R} \Rightarrow |\mathbf{V}|^2 = P \cdot R = (500)(20) \Rightarrow |\mathbf{V}| = 100 \text{ Vrms}$

(b) $\mathbf{I}_s = \mathbf{I} + \mathbf{I}_L = \frac{\mathbf{V}}{20} + \frac{\mathbf{V}}{j20} = \frac{100 \angle 0^\circ}{20} + \frac{100 \angle 0^\circ}{j20} = 5 - j5 = 5\sqrt{2} \angle -45^\circ \text{ A}$

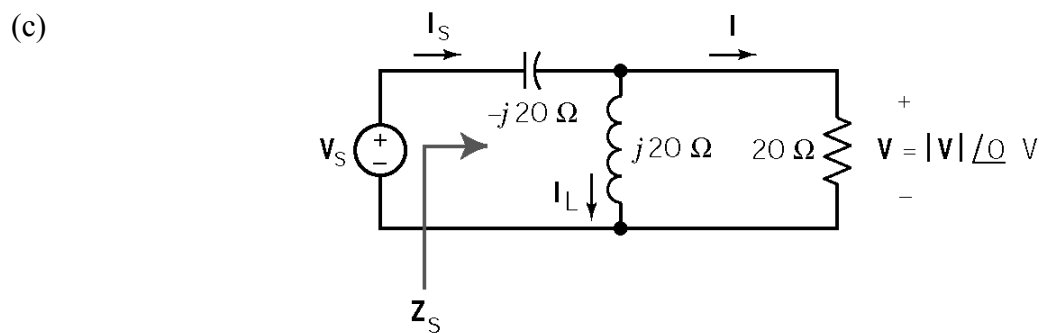

$$\mathbf{Z}_s = -j20 + \frac{(20)(j20)}{20 + j20} = 10\sqrt{2} \angle -45^\circ \Omega$$

$$pf = \cos(-45^\circ) = \frac{1}{\sqrt{2}} \text{ leading}$$

(d) No average power is dissipated in the capacitor or inductor. Therefore,

$$P_{\text{AVE source}} = P_{\text{AVE } 20\Omega} = 500 \text{ W} \Rightarrow |\mathbf{V}_s||\mathbf{I}_s|\cos\theta = 500 \Rightarrow |\mathbf{V}_s| = \frac{500}{|\mathbf{I}_s|\cos\theta} = \frac{500}{(5\sqrt{2})\left(\frac{1}{\sqrt{2}}\right)} = 100 \text{ V}$$

P11.6-5

Load 1: $\mathbf{V} = 100\angle 160^\circ \text{ V}$

$$\mathbf{I} = 2\angle 190^\circ \text{ A} = -1.97 - j0.348 \text{ A}$$

$$P_1 = 23.2 \text{ W}, Q_1 = 50 \text{ VAR}$$

$$\mathbf{S}_1 = P_1 + jQ_1 = 23.2 + j50 = 55.12\angle 65.1^\circ \text{ VA}$$

$$pf_1 = \cos 65.1^\circ = 0.422 \text{ lagging}$$

$$\mathbf{I}_1^* = \frac{\mathbf{S}_1}{\mathbf{V}_s} = \frac{55.12\angle 65.1^\circ}{100\angle 160^\circ} = 0.551\angle -94.9^\circ, \text{ so } \mathbf{I}_1 = 0.551\angle 94.9^\circ \text{ A}$$

Load 2: $\mathbf{I}_2 = \mathbf{I} - \mathbf{I}_1 = -1.97 - j0.348 + 0.047 - j.549 = 2.12\angle -155^\circ \text{ A}$

$$\mathbf{S}_2 = \mathbf{V}\mathbf{I}_2^* = (100\angle 160^\circ)(2.12\angle 155^\circ) = 212\angle -45^\circ = 150 - j150 \text{ VA}$$

$$pf_2 = \cos(-45^\circ) = 0.707 \text{ leading}$$

Total: $\mathbf{S} = \mathbf{S}_1 + \mathbf{S}_2 = (23.2 + j50) + (150 - j150) = 173.2 - j100 = 200\angle -30^\circ \text{ VA}$

$$pf = \cos(-30^\circ) = 0.866 \text{ leading}$$

P11.6-6

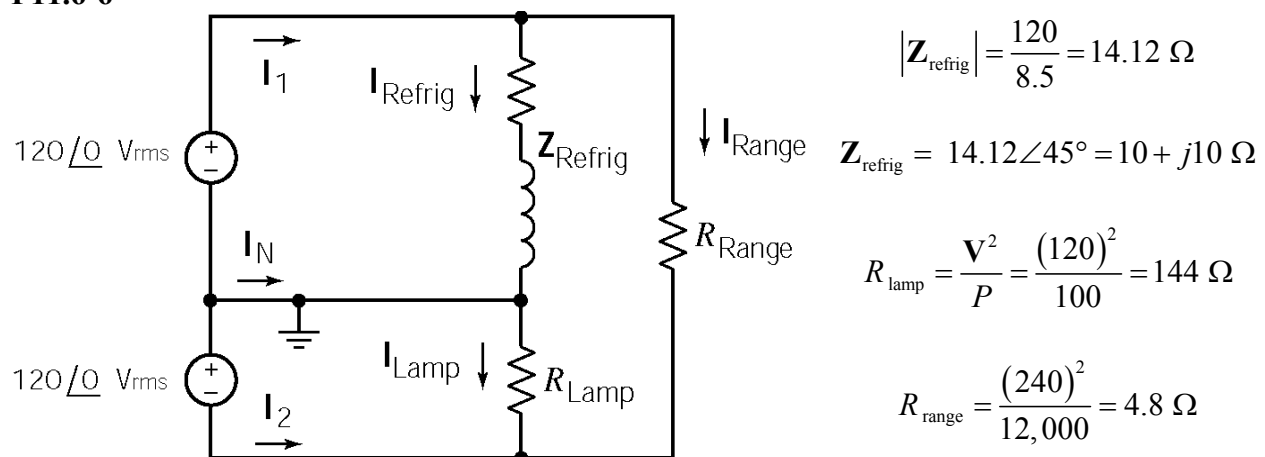

(a) $\mathbf{I}_{\text{refrig}} = \frac{120\angle 0^\circ}{10 + j10} = 8.5\angle -45^\circ \text{ Arms}, \quad \mathbf{I}_{\text{lamp}} = \frac{120\angle 0^\circ}{144} = 0.83\angle 0^\circ \text{ Arms}$

and

$$\mathbf{I}_{\text{range}} = \frac{240 \angle 0^\circ}{4.8} = 50 \angle 0^\circ \text{ A}$$

From KCL:

$$\mathbf{I}_1 = \mathbf{I}_{\text{refrig}} + \mathbf{I}_{\text{range}} = 56 - j6 = \underline{56.3 \angle -6.1^\circ \text{ A}}$$

$$\mathbf{I}_2 = -\mathbf{I}_{\text{lamp}} - \mathbf{I}_{\text{range}} = \underline{50.83 \angle 180^\circ \text{ A}}$$

$$\mathbf{I}_N = -\mathbf{I}_1 - \mathbf{I}_2 = \underline{7.92 \angle -49^\circ \text{ A}}$$

$$(b) \quad P_{\text{refrig}} = |\mathbf{I}_{\text{refrig}}|^2 R_{\text{refrig}} = \underline{722.5 \text{ W}} \quad \text{and} \quad Q_{\text{refrig}} = |\mathbf{I}_{\text{refrig}}|^2 X_{\text{refrig}} = \underline{722.5 \text{ VAR}}$$

$$P_{\text{lamp}} = 100 \text{ W} \quad \text{and} \quad Q_{\text{lamp}} = 0$$

$$\left. \begin{array}{l} P_{\text{total}} = 722 + 100 + 12,000 = 12.82 \text{ kW} \\ Q_{\text{total}} = 722 + 0 + 0 = 722 \text{ VAR} \end{array} \right\} \Rightarrow \mathbf{S} = 12,822 + j722 = 12.84 \angle 3.2^\circ \text{ kVA}$$

The overall power factor is $pf = \cos(3.2^\circ) = 0.998$,

(c)

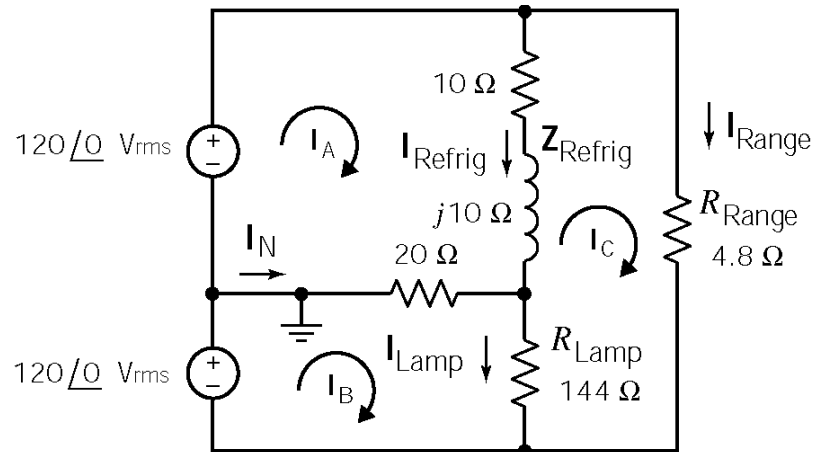

Mesh equations:

$$\begin{bmatrix} 30 + j10 & -20 & -10 - j10 \\ -20 & 164 & -144 \\ -10 - j10 & -144 & 158.8 + j10 \end{bmatrix} \begin{bmatrix} \mathbf{I}_A \\ \mathbf{I}_B \\ \mathbf{I}_C \end{bmatrix} = \begin{bmatrix} 120 \angle 0^\circ \\ 120 \angle 0^\circ \\ 0 \end{bmatrix}$$

Solve to get:

$$\mathbf{I}_A = 54.3 - j1.57 = 54.3 \angle -1.7^\circ \text{ Arms}$$

$$\mathbf{I}_B = 51.3 - j0.19 = 51.3 \angle -0.5^\circ \text{ Arms}$$

$$\mathbf{I}_C = 50 + j0 = 50 \angle 0^\circ \text{ Arms}$$

The voltage across the lamp is

$$|\mathbf{V}_{\text{lamp}}| = R_{\text{lamp}} |\mathbf{I}_B - \mathbf{I}_C| = 144 |1.27 \angle -8.6^\circ| = 183.2 \text{ V}$$

P11.6-7

(a) $VI = 220(7.6) = \underline{1672 \text{ VA}}$

$$\text{pf} = \frac{P}{VI} = \frac{1317}{1672} = \underline{.788}$$

$$\theta = \cos^{-1} \text{pf} = 38.0^\circ \Rightarrow \underline{Q = VI \sin \theta = 1030 \text{ VAR}}$$

(b) To restore the pf to 1.0, a capacitor is required to eliminate Q by introducing -Q, then

$$1030 = \frac{V^2}{X_c} = \frac{(220)^2}{X_c} \Rightarrow X_c = 47 \Omega$$

$$\therefore C = \frac{1}{\omega X} = \frac{1}{(377)(47)} = \underline{56.5 \mu\text{F}}$$

(c) $P = VI \cos \theta$ where $\theta = 0^\circ$

then $1317 = 220I$

$\therefore \underline{I = 6.0 \text{ A}}$ for corrected pf

* Note $I = 7.6 \text{ A}$ for uncorrected pf

P11.6-8

First load:

$$\mathbf{S}_1 = P + jQ = P(1 + j \tan(\cos^{-1}(.6))) = 500(1 + j \tan 53.1^\circ) = 500 + j677 \text{ kVA}$$

Second load:

$$\mathbf{S}_2 = 400 + j600 \text{ kVA}$$

Total:

$$\mathbf{S} = \mathbf{S}_1 + \mathbf{S}_2 = 900 + j1277 \text{ kVA}$$

$$\mathbf{S}_{\text{desired}} = P + jP \tan(\cos^{-1}(.90)) = 900 + j436 \text{ VA}$$

From the vector diagram: $\mathbf{S}_{\text{desired}} = \mathbf{S} + \mathbf{Q}$. Therefore

$$900 + j436 = 900 + j1277 + \mathbf{Q} \Rightarrow \mathbf{Q} = -j841 \text{ VAR}$$

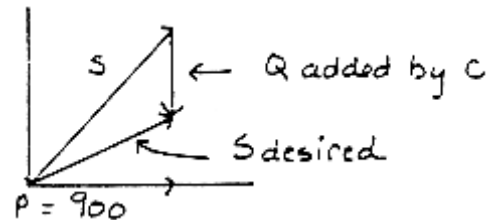

$$\frac{|V|^2}{\mathbf{Z}^*} = -j841 \Rightarrow \mathbf{Z}^* = \frac{|V|^2}{-j841} = \frac{(1000)^2}{-j841} = j1189 \Rightarrow \mathbf{Z} = -j1189 = -\frac{j}{377 \text{ C}}$$

Finally,

$$C = \frac{1}{(1189)(377)} = \underline{2.20 \mu\text{F}}$$

P11.6-9

(a) $S = P + jQ = P + jP \tan(\cos^{-1} pf) = 1000 + j1000 \tan(\cos^{-1} 0.8) = 1000 + j750 \text{ VA}$

Let $V_L = 100 \angle 0^\circ \text{ V}_{\text{rms}}$. Then $I^* = \frac{S}{V_L} = \frac{1000 + j750}{100 \angle 0^\circ} = 10 + j7.5 \Rightarrow I = 10 - j7.5 \text{ A}$

$$Z_L = \frac{V_L}{I} = \frac{100 \angle 0^\circ}{12.5 \angle -36.9^\circ} = 8 \angle 36.9^\circ = 6.4 + j4.8 \text{ } \Omega$$

$$V_L = [6.4 + j(200)(.024) + Z_L](I) = (12.8 + j9.6)(10 - j7.5) = 200 \angle 0^\circ \text{ V}$$

(b) For maximum power transfer, we require $(6.4 + j4.8)^* = Z_L \parallel Z_{\text{new}} = \frac{1}{Y_L + Y_{\text{new}}}$.

$$\frac{1}{(6.4 - j4.8)} = Y_L + Y_{\text{new}} \Rightarrow Y_{\text{new}} = \frac{1}{6.4 - j4.8} - \frac{1}{6.4 + j4.8} = j0.15 \text{ S}$$

Then $Z_{\text{new}} = -j6.67 \text{ } \Omega$ so we need a capacitor given by

$$\frac{1}{\omega C} = 6.67 \Rightarrow C = \frac{1}{(6.67)(200)} = 0.075 \text{ } \mu\text{F}$$

Section 11-7: The Power Superposition Principle

P11.7-1

Use superposition since we have two different frequency sources. First consider the dc source ($\omega = 0$):

$$I_1 = 14 \left(\frac{12}{12+2} \right) = 12 \text{ A}$$

$$P_1 = I_1^2 R = (12)^2 (2) = 288 \text{ W}$$

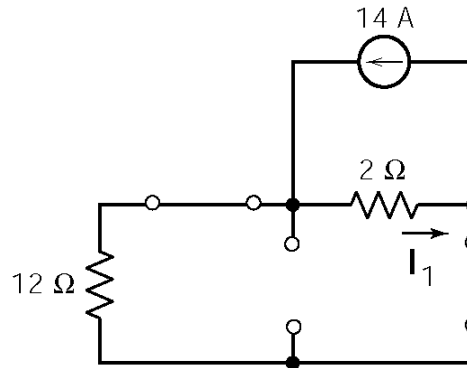

Next, consider the ac source ($\omega = 20 \text{ rad/s}$):

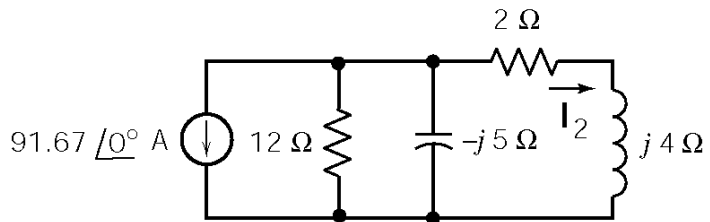
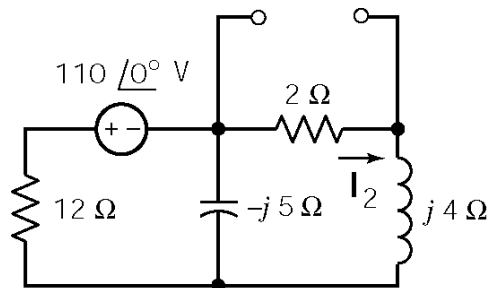

After a source transformation, current division gives

$$\mathbf{I}_2 = -9.166 \left[\frac{\frac{-j60}{(12-j5)}}{\frac{-j60}{(12-j5)} + 2 + j4} \right] = \frac{25}{\sqrt{5}} \angle 116.6^\circ \text{ A}$$

Then

$$P_2 = \frac{|\mathbf{I}_2|^2}{2} (2) = \frac{(125)(2)}{2} = 125 \text{ W}$$

Now using power superposition

$$P = P_1 + P_2 = 288 + 125 = 413 \text{ W}$$

P11.7-2

Use superposition since we have two different frequency sources. First consider $\omega = 2000 \text{ rad/s}$ source:

Current division yields

$$\mathbf{I}_1 = 5 \left[\frac{\frac{8}{-j2}}{\frac{8}{-j2} + 8} \right] = \frac{5}{\sqrt{5}} \angle 63.4^\circ \text{ A}$$

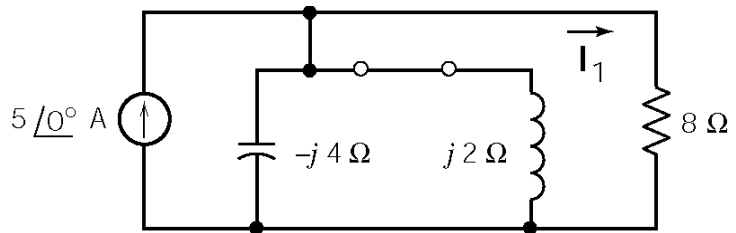

Then

$$P_1 = \frac{|\mathbf{I}_1|^2}{2} 8 = 20 \text{ W}$$

Next consider $\omega = 8000 \text{ rad/s}$ source.

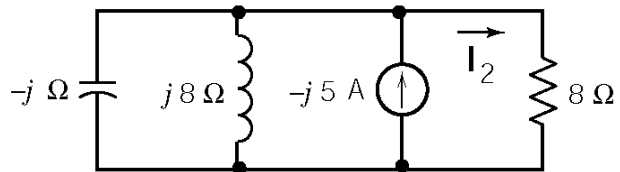
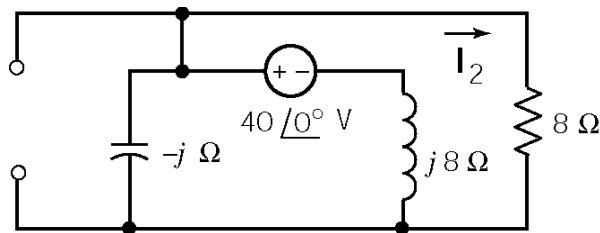

Current division yields

$$\mathbf{I}_2 = -j5 \left[\frac{\frac{8}{j7}}{\frac{8}{j7} + 8} \right] = \frac{5}{\sqrt{50}} \angle -171.9^\circ \text{ A}$$

Then

$$P_2 = \frac{|\mathbf{I}_2|^2 8}{2} = 2 \text{ W}$$

Now using power superposition

$$P = P_1 + P_2 = 22 \text{ W}$$

P11.7-3

Use superposition since we have two different frequency. First consider the dc source ($\omega = 0$):

$$i_2(t) = 0 \text{ and } i_1(t) = 10 \left(\frac{1}{10} \right) = 1 \text{ A}$$

$$P_{R_1} = i_1^2 R_1 = 1^2 (10) = 10 \text{ W}$$

$$P_{R_2} = 0 \text{ W}$$

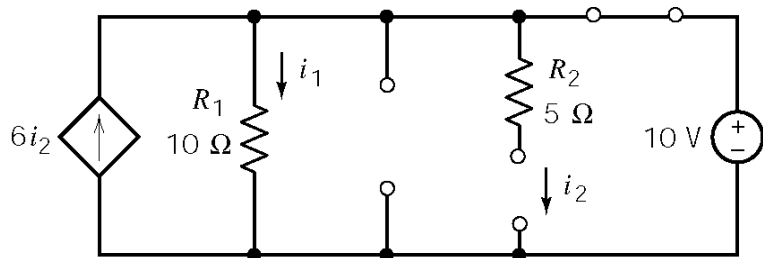

Next consider $\omega = 5 \text{ rad/s}$ sources.

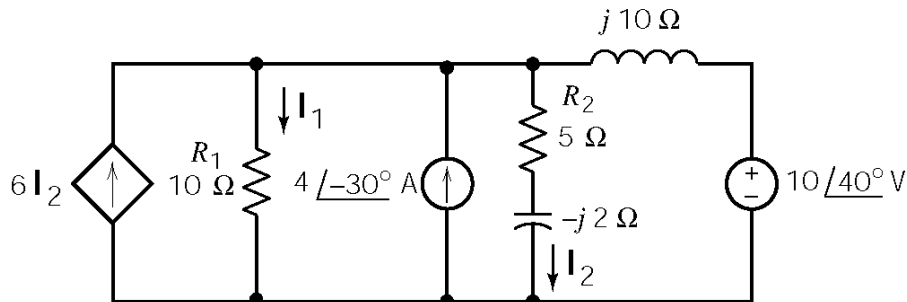

Apply KCL at the top node to get

$$-6\mathbf{I}_2 + \mathbf{I}_1 + \mathbf{I}_2 - (4 \angle -30^\circ) + \frac{(10\mathbf{I}_1 - 10 \angle 40^\circ)}{j10} = 0$$

Apply KVL to get

$$-10\mathbf{I}_1 + (5 - j2)\mathbf{I}_2 = 0$$

Solving these equations gives

$$\mathbf{I}_1 = -0.56 \angle -64.3^\circ \text{ A and } \mathbf{I}_2 = -1.04 \angle -42.5^\circ \text{ A}$$

Then

$$P_{R_1} = \frac{|\mathbf{I}_1|^2 R_1}{2} = \frac{(0.56)^2 (10)}{2} = 1.57 \text{ W} \quad \text{and} \quad P_{R_2} = \frac{|\mathbf{I}_2|^2 R_2}{2} = \frac{(1.04)^2 (5)}{2} = 2.7 \text{ W}$$

Now using power superposition

$$P_{R_1} = 10 + 1.57 = \underline{11.57 \text{ W}} \quad \text{and} \quad P_{R_2} = 0 + 2.7 = \underline{2.7 \text{ W}}$$

P11.7-4

Use superposition since we have two different frequency. First consider the $\omega = 10 \text{ rad/s}$ source:

$$\mathbf{I}_1 = \frac{\mathbf{V}_1}{\mathbf{Z}} = \frac{4 \angle 0^\circ}{2 - j5} = 0.28 + j0.7 \text{ A}$$

$$\mathbf{V}_{R_1} = 2\mathbf{I}_1 = 2(0.28 + j0.7) = 0.56 + j1.4 = 1.51 \angle 68.2^\circ \text{ V}$$

$$\mathbf{V}_{C_1} = -j5\mathbf{I}_1 = 3.77 \angle -21.8^\circ \text{ V}$$

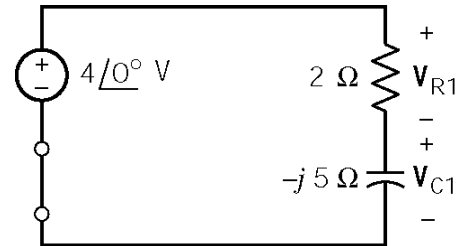

Next consider $\omega = 5 \text{ rad/s}$ source.

$$\mathbf{I}_2 = \frac{\mathbf{V}_2}{\mathbf{Z}} = \frac{6 \angle -90^\circ}{2 - j10} = 0.577 - j0.12 \text{ A}$$

$$\mathbf{V}_{R_2} = 2\mathbf{I}_2 = 2(0.577 - j0.12) = 1.15 - j0.24 \\ = 1.17 \angle -11.8^\circ \text{ V}$$

$$\mathbf{V}_{C_2} = -j10\mathbf{I}_2 = 5.9 \angle 258.3^\circ \text{ V}$$

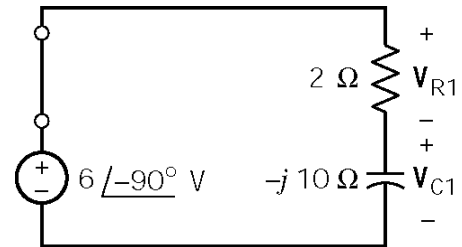

Now using superposition

$$v_R(t) = 1.51 \cos(10t + 68.2^\circ) + 1.17 \cos(5t - 11.8^\circ) \text{ V}$$

$$v_C(t) = 3.77 \cos(10t - 21.8^\circ) + 5.9 \cos(5t - 258.3^\circ) \text{ V}$$

Then

$$V_{\text{Reff}}^2 = \left(\frac{1.51}{\sqrt{2}}\right)^2 + \left(\frac{1.17}{\sqrt{2}}\right)^2 = 1.82 \Rightarrow \underline{V_{\text{Reff}} = 1.35 \text{ V}}$$

$$V_{\text{Ceff}}^2 = \left(\frac{3.77}{\sqrt{2}}\right)^2 + \left(\frac{5.9}{\sqrt{2}}\right)^2 = 24.52 \Rightarrow \underline{V_{\text{Ceff}} = 4.95 \text{ V}}$$

Section 11-8: Maximum Power Transfer Theorem

P11.8-1

$$\mathbf{Z}_t = 4000 \parallel -j2000 = 800 - j1600 \ \Omega$$

$$\mathbf{Z}_L = \mathbf{Z}_t^* = 800 + j1600 \ \Omega$$

$$R + j1000L = 800 + j1600 \Rightarrow \begin{cases} R=800 \ \Omega \\ L=1.6 \ \text{H} \end{cases}$$

P11.8-2

$$\mathbf{Z}_t = 25,000 \parallel -j50,000 = 20,000 - j10,000 \ \Omega$$

$$\mathbf{Z}_L = \mathbf{Z}_t^* = 20,000 + j10,000 \ \Omega$$

$$R + j\omega L = 20,000 + j10,000 \Rightarrow \begin{cases} R=20 \ \text{k}\Omega \\ 100L=10,000 \\ L=100 \ \text{H} \end{cases}$$

After selecting these values of R and L ,

$$|\mathbf{I}| = 1.4 \ \text{mA} \quad \text{and} \quad P_{\max} = \left(\frac{0.14 \times 10^{-2}}{\sqrt{2}} \right)^2 (20 \times 10^3) = 19.5 \ \text{mW}$$

Since $P_{\max} > 12 \ \text{mW}$, yes, we can deliver 12 mW to the load.

P11.8-3

$$\mathbf{Z}_t = 800 + j1600 \ \Omega \quad \text{and} \quad \mathbf{Z}_L = \frac{R \left(\frac{-j}{\omega C} \right)}{R - \frac{j}{\omega C}} = \frac{R - j\omega R^2 C}{1 + (\omega RC)^2}$$

$$\mathbf{Z}_L = \mathbf{Z}_t^* \Rightarrow \frac{R \left(\frac{-j}{\omega C} \right)}{R - \frac{j}{\omega C}} = \frac{R - j\omega R^2 C}{1 + (\omega RC)^2} = 800 - j1600 \ \Omega$$

Equating the real parts gives

$$800 = \frac{R}{1 + (\omega RC)^2} = \frac{4000}{1 + [(5000)(4000)C]^2} \Rightarrow C = 0.1 \ \mu\text{F}$$

P11.8-4

$$\mathbf{Z}_t = 400 + j800 \ \Omega \text{ and } \mathbf{Z}_L = 2000 \parallel -j1000 = 400 - j800 \ \Omega$$

Since $\mathbf{Z}_L = \mathbf{Z}_t^*$ the average power delivered to the load is maximum and cannot be increased by adjusting the value of the capacitance. The voltage across the 2000 Ω resistor is

$$\mathbf{V}_R = 5 \frac{\mathbf{Z}_L}{\mathbf{Z}_t + \mathbf{Z}_L} = 2.5 - j5 = 5.59e^{-j63.4} \text{ V}$$

So

$$P = \left(\frac{5.59}{\sqrt{2}} \right)^2 \frac{1}{2000} = 7.8 \text{ mW}$$

is the average power delivered to the 2000 Ω resistor.

P11.8-5

Notice that \mathbf{Z}_t , not \mathbf{Z}_L , is being adjusted. When \mathbf{Z}_t is fixed, then the average power delivered to the load is maximized by choosing $\mathbf{Z}_L = \mathbf{Z}_t^*$. In contrast, when \mathbf{Z}_L is fixed, then the average power delivered to the load is maximized by minimizing the real part of \mathbf{Z}_t . In this case, choose $R = 0$. Since no average power is dissipated by capacitors or inductors, all of the average power provided by source is delivered to the load.

Section 11-9: Mutual Inductance

P11-9-1

$$\mathbf{V}_s + \mathbf{I} j\omega L_1 + \mathbf{I} j\omega M + \mathbf{I} j\omega L_2 - \mathbf{I} j\omega M = 0$$

$$\Rightarrow j\omega(L_1 + L_2 - 2M) = \frac{\mathbf{V}_s}{\mathbf{I}}$$

Therefore

$$L_{ab} = L_1 + L_2 - 2M$$

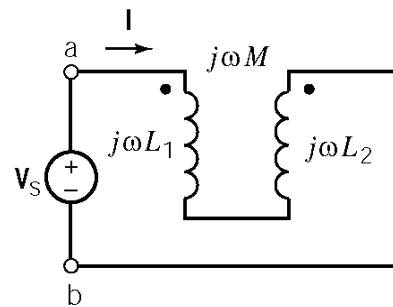

P11.9-2

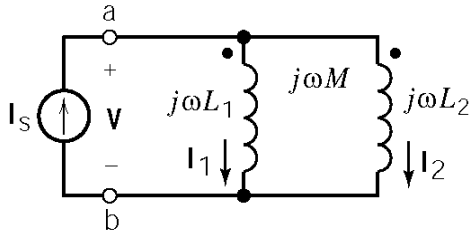

KCL:

$$\mathbf{I}_1 + \mathbf{I}_2 = \mathbf{I}_s$$

The coil voltages are given by:

$$\mathbf{V} = \mathbf{I}_1 j\omega L_1 + \mathbf{I}_2 j\omega M$$

$$\mathbf{V} = \mathbf{I}_2 j\omega L_2 + \mathbf{I}_1 j\omega M$$

Then

$$\mathbf{I}_2 = \frac{\mathbf{V} - j\omega L_1 \mathbf{I}_s}{j\omega(M - L_1)}$$

and

$$\mathbf{V} = \mathbf{I}_2 j\omega L_2 + (\mathbf{I}_s - \mathbf{I}_2) j\omega M$$

Then

$$\mathbf{V} = \frac{(\mathbf{V} - j\omega L_1 \mathbf{I}_s) [j\omega(L_2 - M)]}{j\omega(M - L_1)} + j\omega M \mathbf{I}_s \Rightarrow \frac{\mathbf{V}}{\mathbf{I}_s} = j\omega \left[\frac{L_1 L_2 - M^2}{L_1 + L_2 - 2M} \right]$$

Finally

$$L_{ab} = \frac{L_1 L_2 - M^2}{L_1 + L_2 - 2M}$$

P11.9-3

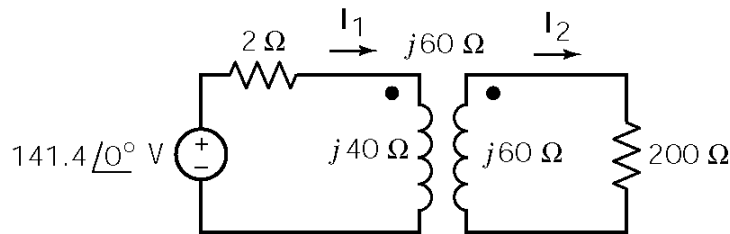

Mesh equations:

$$-141.4 \angle 0^\circ + 2\mathbf{I}_1 + j40\mathbf{I}_1 - j60\mathbf{I}_2 = 0$$

$$1200\mathbf{I}_2 + j60\mathbf{I}_2 - j60\mathbf{I}_1 = 0 \Rightarrow \mathbf{I}_2 = (0.23 \angle 51^\circ) \mathbf{I}_1$$

Solving yields

$$\mathbf{I}_1 = 4.17 \angle -68^\circ \text{ A and } \mathbf{I}_2 = 0.96 \angle -17^\circ \text{ A}$$

Finally

$$\underline{i_1(t) = 4.2 \cos(100t - 68^\circ) \text{ A}} \text{ and } \underline{i_2(t) = 1.0 \cos(100t - 17^\circ) \text{ A}}$$

P11.9-4

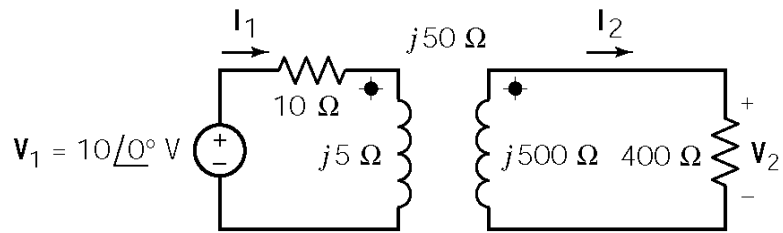

Mesh equations:

$$\begin{aligned} (10+j5) \mathbf{I}_1 - j50 \mathbf{I}_2 &= 10 \\ -j50 \mathbf{I}_1 + (400+j500) \mathbf{I}_2 &= 0 \end{aligned}$$

Solving the mesh equations using Cramer's rule:

$$\mathbf{I}_2 = \frac{(10+j5)(0) - (-j50)(10)}{(10+j5)(400+j500) - (-j50)^2} = 0.062 \angle 29.7^\circ \text{ A}$$

Then

$$\frac{\mathbf{V}_2}{\mathbf{V}_1} = \frac{400 \mathbf{I}_2}{10 \angle 0^\circ} = 40 \mathbf{I}_2 = 40 (0.062 \angle 29.7^\circ) = 2.5 \angle 29.7^\circ$$

P11.9-5

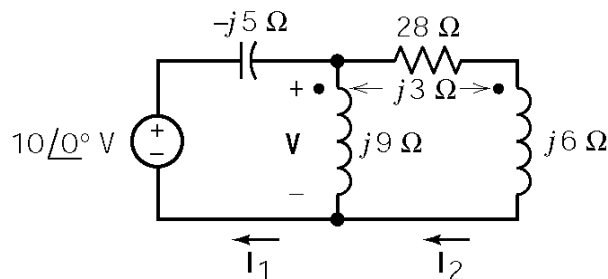

Mesh equations:

$$\begin{aligned} -10 \angle 0^\circ - j5 \mathbf{I}_1 + j9 \mathbf{I}_1 + j3 \mathbf{I}_2 &= 0 \\ 28 \mathbf{I}_2 + j6 \mathbf{I}_2 + j3 \mathbf{I}_1 + j9 \mathbf{I}_2 - j3 \mathbf{I}_2 &= 0 \end{aligned}$$

Solving the mesh equations yields

$$\mathbf{I}_1 = 0.25 \angle 161^\circ \text{ A} \text{ and } \mathbf{I}_2 = 2.55 \angle -86^\circ \text{ A}$$

then

$$\mathbf{V} = j9(\mathbf{I}_1 - \mathbf{I}_2) = j9(2.6 \angle -81^\circ) = 23 \angle 9^\circ \text{ V}$$

Finally

$$v(t) = 23 \cos(30t + 9^\circ) \text{ V}$$

P11.9-6

(a)

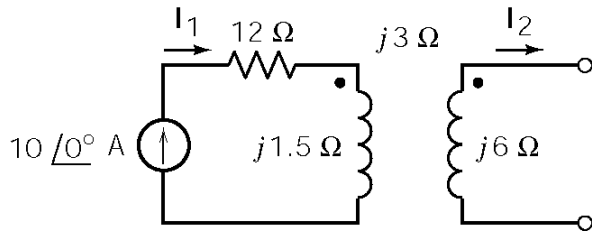

$$\mathbf{I}_2 = 0 \Rightarrow \mathbf{I}_1 = 10 \angle 0^\circ \text{ A} \Rightarrow i_1(0) = 10 \text{ A}$$

$$w = \frac{L_1 i_1^2(0)}{2} = \frac{(0.3)(10)^2}{2} = 15 \text{ J}$$

(b)

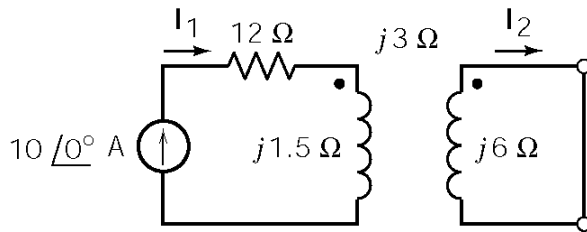

Mesh equations:

$$j6 \mathbf{I}_2 - j3 \mathbf{I}_1 = 0 \Rightarrow \mathbf{I}_1 = 2 \mathbf{I}_2$$

$$\mathbf{I}_1 = 10 \angle 0^\circ \text{ A} \Rightarrow \mathbf{I}_2 = 5 \angle 0^\circ \text{ A}$$

Then

$$w = \frac{1}{2} L_1 i_1^2(0) + \frac{1}{2} L_2 i_2^2(0) - M i_1(0) i_2(0) = \frac{1}{2} (0.3)(10)^2 + \frac{1}{2} (1.2)(5)^2 - (0.6)(10)(5) = 0$$

(c)

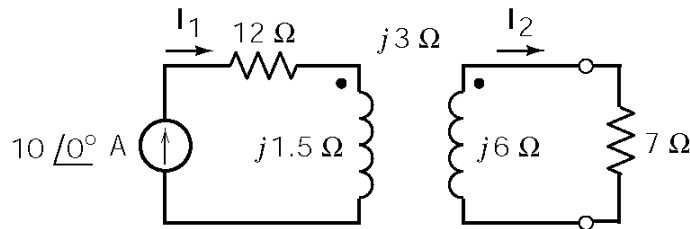

$$(7 + j6) \mathbf{I}_2 - j3 \mathbf{I}_1 = 0$$

$$\mathbf{I}_2 = 3.25 \angle 49.4^\circ \text{ A}$$

$$i_2(t) = 3.25 \cos(5t + 49.4^\circ) \text{ A}$$

$$i_2(0) = 2.12 \text{ A}$$

Finally

$$w = \frac{1}{2} (0.3)(10)^2 + \frac{1}{2} (1.2)(2.12)^2 - (0.6)(10)(2.12) = 5.0 \text{ J}$$

P11.9-7

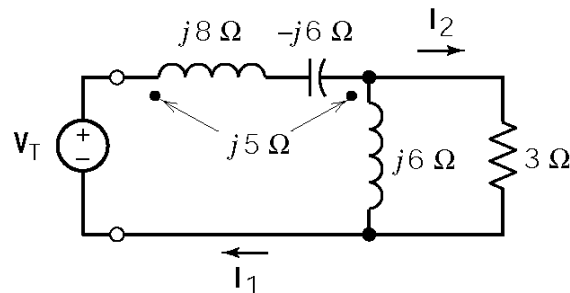

Mesh equations:

$$-V_T + j8\mathbf{I}_1 + j5(\mathbf{I}_1 - \mathbf{I}_2) - j6\mathbf{I}_1 + j6(\mathbf{I}_1 - \mathbf{I}_2) + j5\mathbf{I}_1 = 0$$

$$3\mathbf{I}_2 + j6(\mathbf{I}_2 - \mathbf{I}_1) - j5\mathbf{I}_1 = 0$$

Solving yields

$$\mathbf{I}_2 = (1.64 \angle 27^\circ) \mathbf{I}_1$$

$$\mathbf{I}_1(j18) + \mathbf{I}_2(-j11) = \mathbf{V}_T$$

Then

$$\mathbf{Z} = \frac{\mathbf{V}_T}{\mathbf{I}_1} = 8.2 + j^2 = 8.4 \angle 14^\circ \Omega$$

P11.9-8

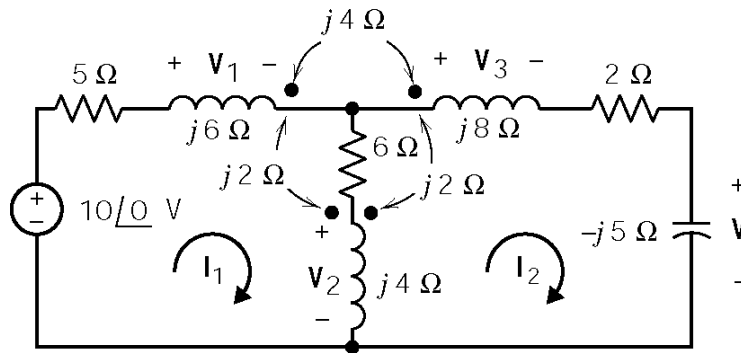

The coil voltages are given by

$$\mathbf{V}_1 = j6\mathbf{I}_1 - j2(\mathbf{I}_1 - \mathbf{I}_2) - j4\mathbf{I}_2 = j4\mathbf{I}_1 - j2\mathbf{I}_2$$

$$\mathbf{V}_2 = j4(\mathbf{I}_1 - \mathbf{I}_2) - j2\mathbf{I}_1 + j2\mathbf{I}_2 = j2\mathbf{I}_1 - j2\mathbf{I}_2$$

$$\mathbf{V}_3 = j8\mathbf{I}_2 - j4\mathbf{I}_1 + j2(\mathbf{I}_1 - \mathbf{I}_2) = -j2\mathbf{I}_1 + j6\mathbf{I}_2$$

The mesh equations are

$$5\mathbf{I}_1 + \mathbf{V}_1 + 6(\mathbf{I}_1 - \mathbf{I}_2) + \mathbf{V}_2 = 10\angle 0^\circ$$

$$-\mathbf{V}_2 + 6(\mathbf{I}_2 - \mathbf{I}_1) + 2\mathbf{I}_2 + \mathbf{V}_3 - j5\mathbf{I}_2 = 0$$

Combining and solving yields

$$\mathbf{I}_2 = \frac{\begin{vmatrix} 11+j6 & 10 \\ -6-j4 & 0 \end{vmatrix}}{\begin{vmatrix} 11+j6 & -6-j4 \\ -6-j4 & 8+j3 \end{vmatrix}} = \frac{60 + j40}{50 + j33} = 1.2 \angle 0.28^\circ \text{ A}$$

Finally

$$\mathbf{V} = -j5\mathbf{I}_2 = 6.0 \angle -89.72^\circ \text{ A} \Rightarrow v(t) = 6\sin(2t - 89.7^\circ) \text{ V}$$

Section 11-10: The Ideal Transformer

P11.10-1

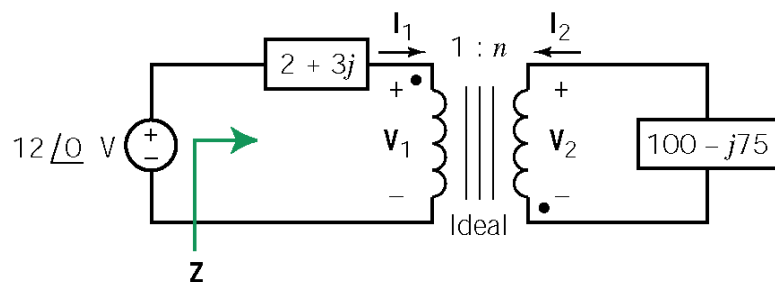

$$\mathbf{Z} = (2 + j3) + \frac{(100 - j75)}{5^2} = 6 \Omega$$

$$\mathbf{I}_1 = \frac{12 \angle 0^\circ}{\mathbf{Z}} = \frac{12 \angle 0^\circ}{6} = 2 \text{ A}$$

$$\mathbf{V}_1 = \mathbf{I}_1 \left(\frac{100 - j75}{n^2} \right) = (2) \left(\frac{100 - j75}{25} \right) = 10 \angle -36.9^\circ \text{ V}$$

$$\mathbf{V}_2 = n\mathbf{V}_1 = 5 (10 \angle -36.9^\circ) = 50 \angle -36.9^\circ \text{ V}$$

$$\mathbf{I}_2 = \frac{\mathbf{I}_1}{n} = \frac{2}{5} \text{ A}$$

P11.10-2

(a) $\mathbf{V}_0 = (5 \times 10^{-3})(10,000) = 50 \text{ V}$

$$n = \frac{N_2}{N_1} = \frac{\mathbf{V}_0}{\mathbf{V}_1} = \frac{50}{10} = 5$$

(b) $R_{ab} = \frac{1}{n^2} R_2 = \frac{1}{25} (10 \times 10^3) = 400 \Omega$

(c) $\mathbf{I}_s = \frac{10}{R_{ab}} = \frac{10}{400} = 0.025 \text{ A} = 25 \text{ mA}$

P11.10-3

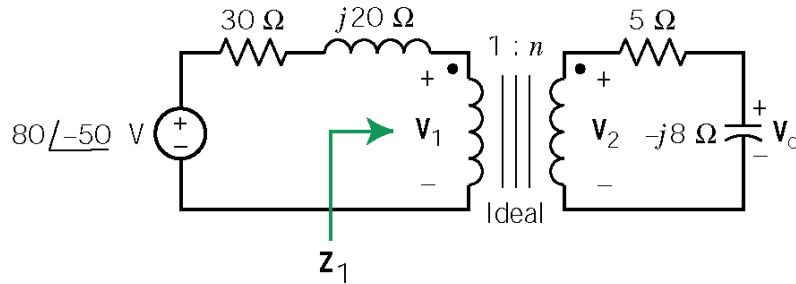

$$\mathbf{Z}_1 = \frac{1}{n^2} \mathbf{Z}_2 = 9 \mathbf{Z}_2 = 9(5 - j8) = 45 - j72 \Omega$$

Using voltage division, the voltage across \mathbf{Z}_1 is

$$\mathbf{V}_1 = (80 \angle -50^\circ) \left(\frac{45 - j72}{45 - j72 + 30 + j20} \right) = 74.4 \angle -73.3^\circ \text{ V}$$

then

$$\mathbf{V}_2 = n \mathbf{V}_1 = \frac{74.4 \angle -73.3^\circ}{3} = 24.8 \angle -73.3^\circ \text{ V}$$

Using voltage division again yields

$$\mathbf{V}_c = \mathbf{V}_2 \left(\frac{-j8}{5 - j8} \right) = (24.8 \angle -73.3^\circ) \left(\frac{8 \angle -90^\circ}{\sqrt{89} \angle -58^\circ} \right) = 21.0 \angle -105.3^\circ \text{ V}$$

P11.10-4

$$n = 5, \quad \mathbf{Z}_1 = \frac{200}{(5)^2} = 8 \Omega \quad \Rightarrow \quad \mathbf{V}_1 = \frac{8}{8+2} (50 \angle 0^\circ) = 40 \angle 0^\circ \text{ V} \quad \Rightarrow \quad \mathbf{V}_2 = n \mathbf{V}_1 = 200 \angle 0^\circ \text{ V}$$

P11.10-5

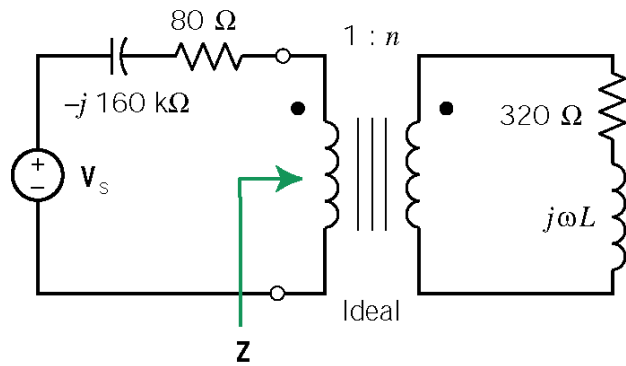

$$\mathbf{Z} = \frac{320}{n^2} + \frac{j\omega L}{n^2}$$

Maximum power transfer requires

$$\frac{j\omega L}{n^2} = j160 \text{ k}\Omega \quad \text{and} \quad \frac{320}{n^2} = 80$$

so $n = 2$. Then $\omega L = 640 \text{ k}\Omega$ so

$$L = \frac{640 \times 10^3}{10^5} = 6.4 \text{ H}$$

P11.10-6

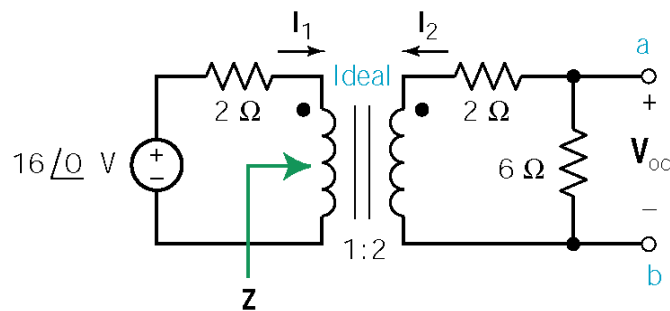

$$\mathbf{Z} = \frac{1}{2^2}(2+6) = 2 \Omega$$

$$\mathbf{V}_{oc} = \left(\frac{6}{6+2}\right)(2) \left(\left(\frac{2}{2+2}\right)16\angle 0^\circ\right) = 12\angle 0^\circ \text{ V}$$

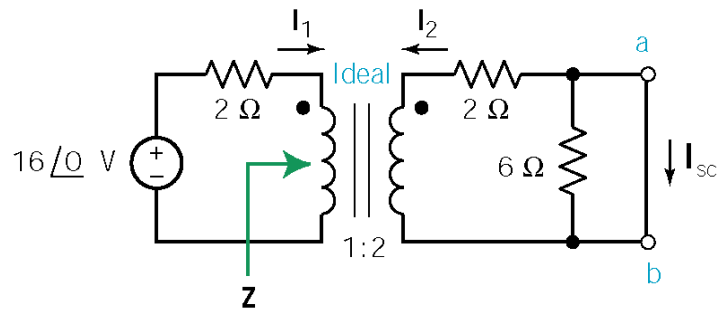

$$\mathbf{Z} = \frac{1}{2^2}(2) = \frac{1}{2} \Omega$$

$$\mathbf{I}_{sc} = -\mathbf{I}_2 = \frac{1}{2}\mathbf{I}_1 = \frac{1}{2} \left(\frac{16\angle 0^\circ}{2 + \frac{1}{2}} \right) = 3.25\angle 0^\circ \text{ A}$$

Then

$$\mathbf{Z}_t = \frac{12\angle 0^\circ}{3.2\angle 0^\circ} = 3.75\angle 0^\circ \Omega$$

P11.10-7

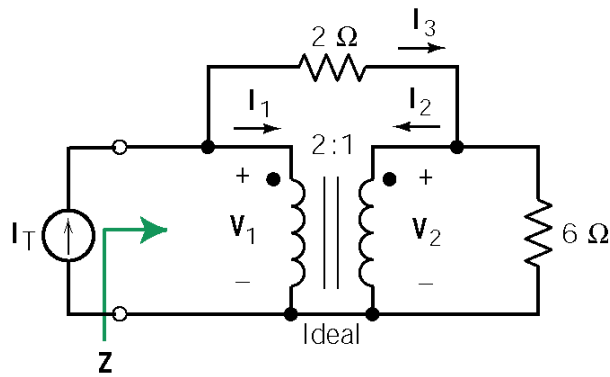

$$V_2 = \frac{1}{2} V_1$$

$$I_3 = \frac{V_1 - V_2}{2} = \frac{V_1}{4}$$

$$I_2 = I_3 - \frac{V_2}{6} = \frac{V_1}{6}$$

$$I_1 = -\frac{1}{2} I_2 = -\frac{V_1}{12}$$

$$I_T = I_3 - I_1 = \frac{V_1}{6}$$

$$Z = \frac{V_1}{I_T} = 6$$

P11.10-8

Maximum power transfer requires $Z_L = Z_t^*$. First

$$X_{Cl} \left(\frac{1}{n_2^2} \right) = X_{L1}, \quad \frac{1}{n_2^2} = \frac{2}{10} = \frac{1}{5} \Rightarrow n_2 = \sqrt{5}$$

then

$$\left[R_L \left(\frac{1}{n_2^2} \right) + 1 \right] \left(\frac{1}{n_1^2} \right) = 100 \, \Omega \Rightarrow \frac{1}{n_1^2} = \frac{100}{3} \Rightarrow n_1 = \frac{\sqrt{3}}{10}$$

P11.10-9

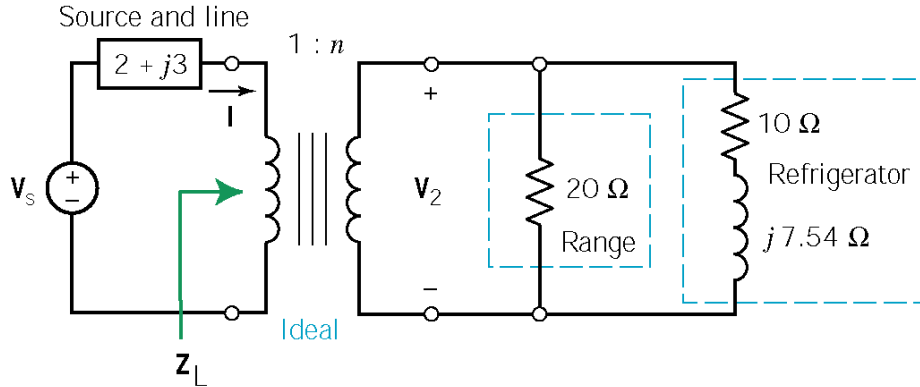

$$\mathbf{Z}_L = \frac{1}{5^2} \left(\frac{20(1+j7.54)}{20+10+j7.54} \right) = \frac{8.1 \angle 23^\circ}{25} = 0.3 + j0.13 \Omega$$

$$P_L = \frac{|\mathbf{V}_L|^2}{2R_2} = \frac{|\mathbf{V}_2|^2}{2R_L} = \frac{(230)^2}{2(0.3)} = 88 \text{ kW/home}$$

Therefore, 529 kW are required for six homes.

P11.10-10

(a)

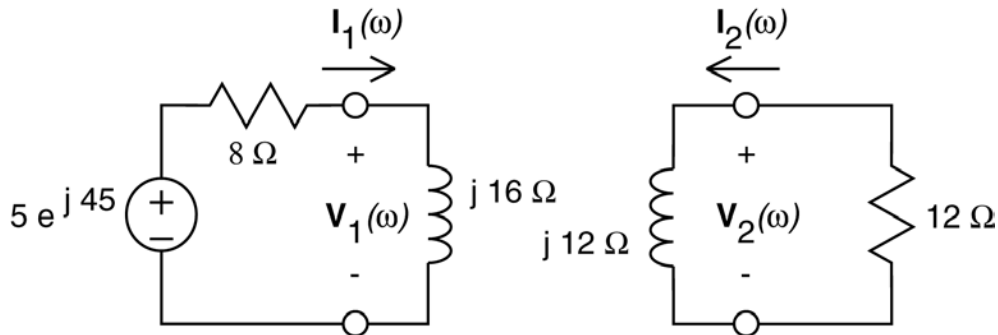

Coil voltages:

$$\mathbf{V}_1 = j16 \mathbf{I}_1$$

$$\mathbf{V}_2 = j12 \mathbf{I}_2$$

Mesh equations:

$$8 \mathbf{I}_1 + \mathbf{V}_1 - 5 \angle 45^\circ = 0$$

$$-12 \mathbf{I}_2 - \mathbf{V}_2 = 0$$

Substitute the coil voltages into the mesh equations and do some algebra:

$$8 \mathbf{I}_1 + j16 \mathbf{I}_1 = 5 \angle 45^\circ \Rightarrow \mathbf{I}_1 = 0.28 \angle -18.4^\circ$$

$$12 \mathbf{I}_2 + j12 \mathbf{I}_2 = 0 \Rightarrow \mathbf{I}_2 = 0$$

$$\mathbf{V}_2 = -12 \mathbf{I}_2 = 0$$

(b)

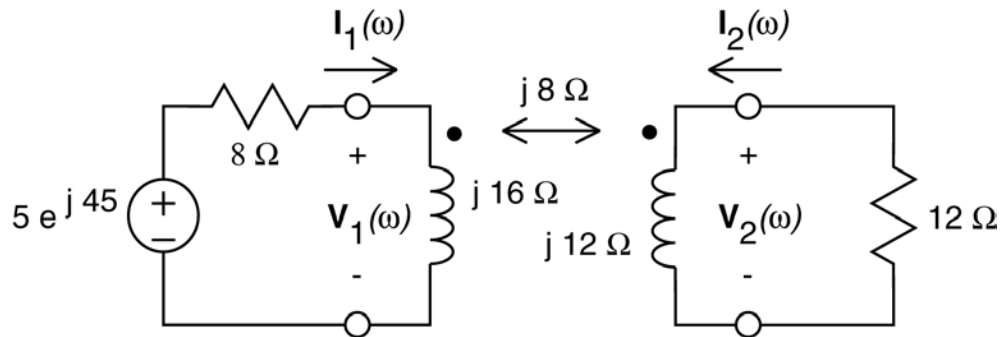

Coil voltages:

$$\mathbf{V}_1 = j16 \mathbf{I}_1 + j8 \mathbf{I}_2$$

$$\mathbf{V}_2 = j12 \mathbf{I}_2 + j8 \mathbf{I}_1$$

Mesh equations:

$$8 \mathbf{I}_1 + \mathbf{V}_1 - 5 \angle 45^\circ = 0$$

$$-12 \mathbf{I}_2 - \mathbf{V}_2 = 0$$

Substitute the coil voltages into the mesh equations and do some algebra:

$$8 \mathbf{I}_1 + (j16 \mathbf{I}_1 + j8 \mathbf{I}_2) = 5 \angle 45^\circ$$

$$12 \mathbf{I}_2 + (j12 \mathbf{I}_2 + j8 \mathbf{I}_1) = 0$$

$$\mathbf{I}_1 = -\frac{12 + j12}{j8} \mathbf{I}_2 = \frac{3}{2}(j-1) \mathbf{I}_2$$

$$\left[(8 + j16) \left(\frac{3}{2} \right) (j-1) + j8 \right] \mathbf{I}_2 = 5 \angle 45^\circ \Rightarrow \mathbf{I}_2 = 0.138 \angle -141^\circ$$

$$\mathbf{V}_2 = -12 \mathbf{I}_2 = 1.656 \angle 39^\circ$$

(c)

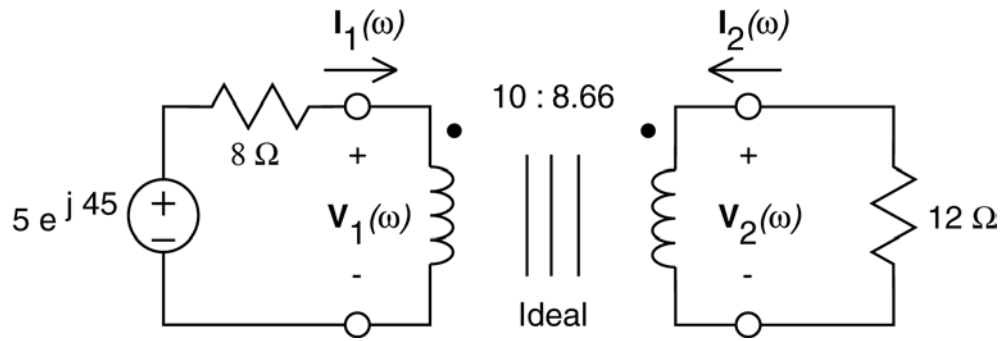

Coil voltages and currents:

$$\mathbf{V}_1 = \frac{10}{8.66} \mathbf{V}_2$$
$$\mathbf{I}_1 = -\frac{8.66}{10} \mathbf{I}_2$$

Mesh equations:

$$8 \mathbf{I}_1 + \mathbf{V}_1 - 5 \angle 45^\circ = 0$$
$$-12 \mathbf{I}_2 - \mathbf{V}_2 = 0$$

Substitute into the second mesh equation and do some algebra:

$$-12 \left(-\frac{10}{8.66} \mathbf{I}_1 \right) = \frac{8.66}{10} \mathbf{V}_1 \Rightarrow \mathbf{V}_1 = 12 \left(\frac{10}{8.66} \right)^2 \mathbf{I}_1$$

$$8 \mathbf{I}_1 + 12 \left(\frac{10}{8.66} \right)^2 \mathbf{I}_1 = 5 \angle 45^\circ \Rightarrow \mathbf{I}_1 = 0.208 \angle 45^\circ$$

$$\mathbf{V}_2 = -12 \mathbf{I}_2 = -12 \left(-\frac{10}{8.66} \mathbf{I}_1 \right) = \frac{12(10)}{8.66} 0.208 \angle 45^\circ = 2.88 \angle 45^\circ$$

PSpice Problems

SP 11-1

The coupling coefficient is $k = \frac{3}{\sqrt{2 \times 5}} = 0.94868$.

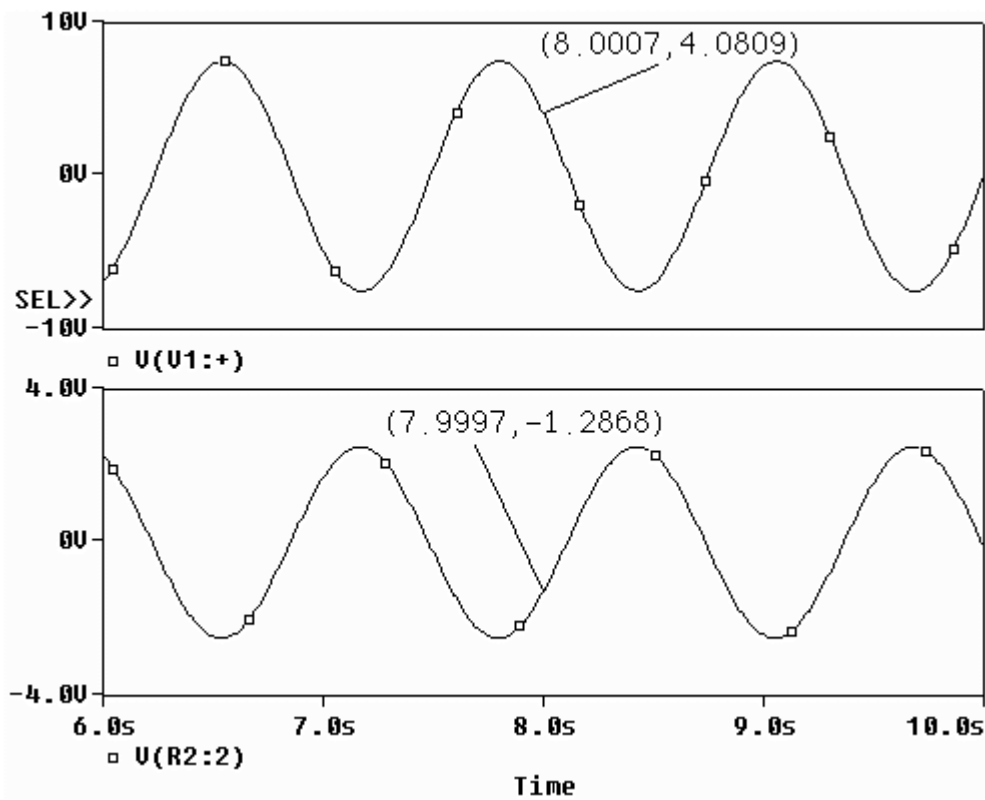
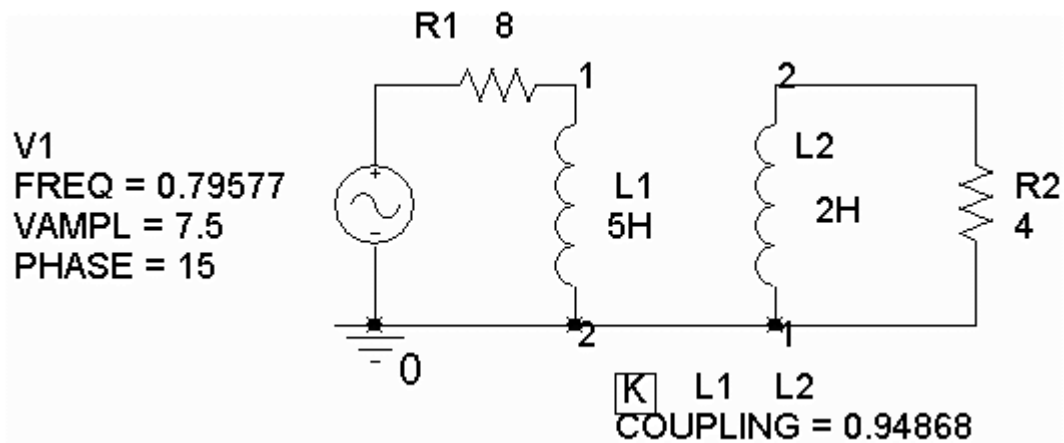

SP 11-2

Here is the circuit with printers inserted to measure the coil voltages and currents:

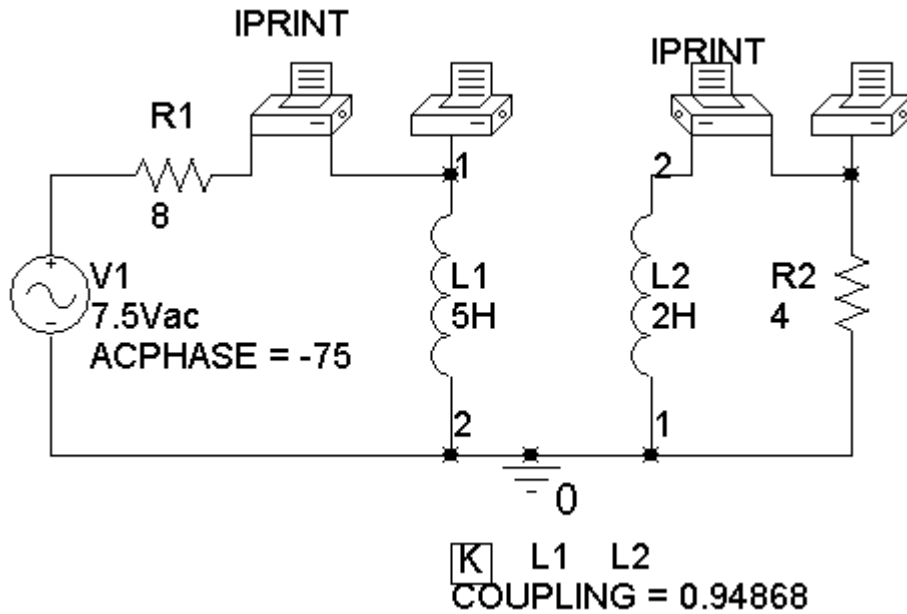

Here is the output from the printers, giving the voltage of coil 2 as $2.498\angle 107.2^\circ$, the current of coil 1 as $0.4484\angle -94.57^\circ$, the current of coil 2 as $0.6245\angle -72.77^\circ$ and the voltage of coil 1 as $4.292\angle -58.74^\circ$:

```

FREQ          VM(N00984)  VP(N00984)
7.958E-01     2.498E+00    1.072E+02

FREQ
IM(V_PRINT1) IP(V_PRINT1)
7.958E-01     4.484E-01    -9.457E+01

FREQ
IM(V_PRINT2) IP(V_PRINT2)
7.958E-01     6.245E-01    -7.277E+01

FREQ          VM(N00959)  VP(N00959)
7.958E-01     4.292E+00    -5.874E+01
    
```

The power received by the coupled inductors is

$$p = \frac{(4.292)(0.4484)}{2} \cos(-58.74 - (-94.57)) + \frac{(2.498)(0.6245)}{2} \cos(107.2 - (-72.77)) \\
 = 0.78016 - .78000 \approx 0$$

SP 11-3

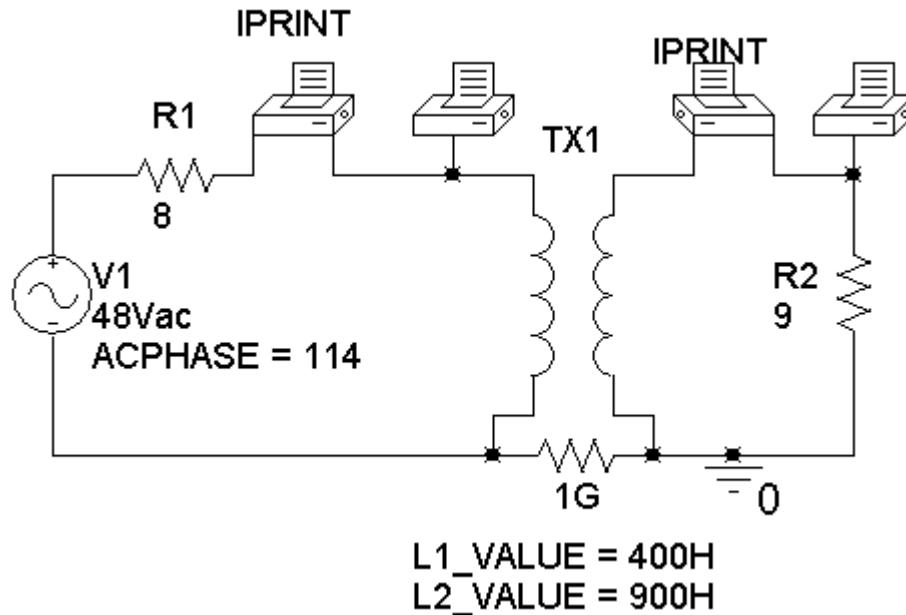

The inductance are selected so that $\sqrt{\frac{L_2}{L_1}} = \frac{N_2}{N_1} = \frac{3}{2}$ and the impedance of these inductors are much larger than other impedance in the circuit. The 1 GΩ resistor simulates an open circuit while providing a connected circuit.

Here is the output from the printers, giving the voltage of coil 2 as $24.00\angle 114.1^\circ$, the current of coil 1 as $4.000\angle 114.0^\circ$, the current of coil 2 as $2.667\angle -65.90^\circ$ and the voltage of coil 1 as $16.00\angle 114.1^\circ$:

```

FREQ          VM(N00984)  VP(N00984)
6.366E-01     2.400E+01  1.141E+02

FREQ
IM(V_PRINT1) IP(V_PRINT1)
6.366E-01     4.000E+00  1.140E+02

FREQ
IM(V_PRINT2) IP(V_PRINT2)
6.366E-01     2.667E+00 -6.590E+01

FREQ          VM(N00959)  VP(N00959)
6.366E-01     1.600E+01  1.141E+02
    
```

The power received by the transformer is

$$\begin{aligned}
 p &= \frac{(16)(4)}{2} \cos(114 - 114) + \frac{(24)(2.667)}{2} \cos(114 - (-66)) \\
 &= 32 - 32.004 \approx 0
 \end{aligned}$$

SP 11-4

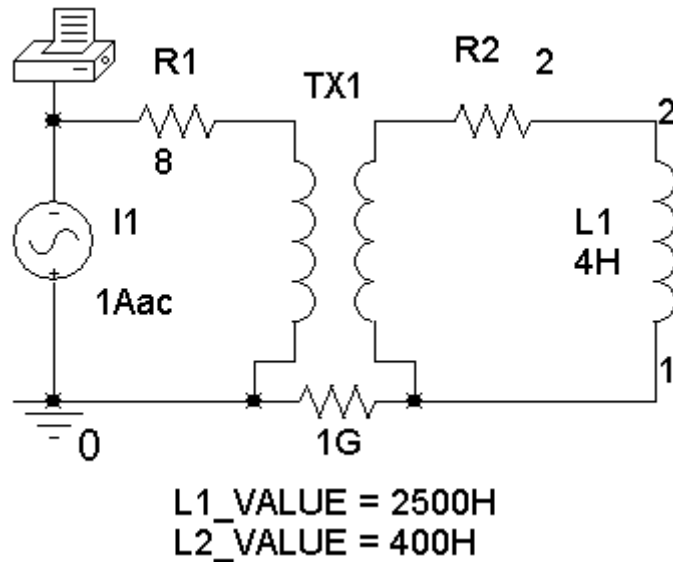

The inductance are selected so that $\sqrt{\frac{L_2}{L_1}} = \frac{N_2}{N_1} = \frac{2}{5}$ and the impedance of these inductors are much larger than other impedance in the circuit. The 1 GΩ resistor simulates an open circuit while providing a connected circuit.

FREQ	VM(N00921)	VP(N00921)	VR(N00921)	VI(N00921)
6.366E-01	1.011E+02	7.844E+01	2.025E+01	9.903E+01

The printer output gives the voltage across the current source as

$$20.25 + j99.03 = 101.1 \angle 78.44^\circ \text{ V}$$

The input impedance is

$$\mathbf{Z}_t = \frac{20.25 + j99.03}{1} = 20.25 + j99.03 \text{ } \Omega = 101.1 \angle 78.44^\circ \text{ } \Omega$$

(We expected $\mathbf{Z}_t = 8 + \left(\frac{5^2}{2^2}\right)(2 + j(4)(4)) = 20.5 + j100 \text{ } \Omega$. That's about 1% error.)

Verification Problems

VP 11-1

The average power supplied by the source is

$$P_s = \frac{(12)(2.327)}{2} \cos(30^\circ - (-25.22^\circ)) = 7.96 \text{ W}$$

Capacitors and inductors receive zero average power, so the sum of the average powers received by the other circuit elements is equal to the sum of the average powers received by the resistors:

$$P_R = \frac{2.327^2}{2}(4) + \frac{1.129^2}{2}(2) = 10.83 + 1.27 = 12.10 \text{ W}$$

The average power supplied by the voltage source is equal to the sum of the average powers received by the other circuit elements. **The mesh currents cannot be correct.**

(What went wrong? It appears that the resistances of the two resistors were interchanged when the data was entered for the computer analysis. Notice that

$$P_R = \frac{2.327^2}{2}(2) + \frac{1.129^2}{2}(4) = 5.41 + 2.55 = 7.96 \text{ W}$$

The mesh currents would be correct if the resistances of the two resistors were interchanged. The computer was used to analyze the wrong circuit.)

VP 11-2

The average complex supplied by the source is

$$S_s = \frac{(12\angle 30^\circ)(1.647\angle -17.92^\circ)^*}{2} = \frac{(12\angle 30^\circ)(1.647\angle 17.92^\circ)}{2} = 9.88\angle 47.92^\circ = 6.62 + j7.33 \text{ W}$$

The complex power received by the 4 Ω resistor is

$$S_{4\Omega} = \frac{(4 \times 1.647\angle -17.92^\circ)(1.647\angle -17.92^\circ)^*}{2} = 5.43 + j0 \text{ VA}$$

The complex power received by the 2 Ω resistor is

$$S_{2\Omega} = \frac{(2 \times 1.094\angle -13.15^\circ)(1.094\angle -13.15^\circ)^*}{2} = 1.20 + j0 \text{ VA}$$

The current in the 2 H inductor is

$$(1.647 \angle -17.92^\circ) - (1.094 \angle -13.15^\circ) = 0.5640 \angle -27.19^\circ$$

The complex power received by the 2 H inductor is

$$\mathbf{S}_{2H} = \frac{(j8 \times 0.5640 \angle -27.19^\circ)(0.5640 \angle -27.19^\circ)^*}{2} = 0 + j1.27 \text{ VA}$$

The complex power received by the 4 H inductor is

$$\mathbf{S}_{4H} = \frac{(j16 \times 1.094 \angle -13.15^\circ)(1.094 \angle -13.15^\circ)^*}{2} = 0 + j9.57 \text{ VA}$$

$$\mathbf{S}_{4\Omega} + \mathbf{S}_{2\Omega} + \mathbf{S}_{2H} + \mathbf{S}_{4H} = (5.43 + j0) + (1.20 + j0) + (0 + j1.27) + (0 + j9.57) = 6.63 + j10.84 \neq \mathbf{S}_s$$

The complex power supplied by the voltage source is equal to the sum of the complex powers received by the other circuit elements. **The mesh currents cannot be correct.**

(Suppose the inductances of the inductors were interchanged. Then the complex power received by the 4 H inductor would be

$$\mathbf{S}_{4H} = \frac{(j16 \times 0.5640 \angle -27.19^\circ)(0.5640 \angle -27.19^\circ)^*}{2} = 0 + j2.54 \text{ VA}$$

The complex power received by the 2 H inductor would be

$$\mathbf{S}_{2H} = \frac{(j8 \times 1.094 \angle -13.15^\circ)(1.094 \angle -13.15^\circ)^*}{2} = 0 + j4.79 \text{ VA}$$

$$\mathbf{S}_{4\Omega} + \mathbf{S}_{2\Omega} + \mathbf{S}_{2H} + \mathbf{S}_{4H} = (5.43 + j0) + (1.20 + j0) + (0 + j2.54) + (0 + j4.79) = 6.63 + j7.33 \approx \mathbf{S}_s$$

The mesh currents would be correct if the inductances of the two inductors were interchanged. The computer was used to analyze the wrong circuit.)

VP 11-3

The voltage across the right coil must be equal to the voltage source voltage. Notice that the mesh currents both enter the undotted ends of the coils. In the frequency domain, the voltage across the right coil is

$$\begin{aligned}
 (j16)(1.001\angle -47.01^\circ) + (j12)(0.4243\angle -15^\circ) &= 16.016\angle 42.99^\circ + 5.092\angle 75^\circ \\
 &= (11.715 + j10.923) + (1.318 + j4.918) \\
 &= 13.033 + j15.841 \\
 &= 20.513\angle 50.55^\circ
 \end{aligned}$$

This isn't equal to the voltage source voltage so the computer analysis isn't correct.

What happened? A data entry error was made while doing the computer analysis. Both coils were described as having the dotted end at the top. If both coils had the dot at the top, the equation for the voltage across the right coil would be

$$\begin{aligned}
 (j16)(1.001\angle -47.01^\circ) - (j12)(0.4243\angle -15^\circ) &= 16.016\angle 42.99^\circ - 5.092\angle 75^\circ \\
 &= (11.715 + j10.923) - (1.318 + j4.918) \\
 &= 10.397 + j6.005 \\
 &= 12.007\angle 30.01^\circ
 \end{aligned}$$

This is equal to the voltage source voltage. The computer was used to analyze the wrong circuit.

VP 11-4

First check the ratio of the voltages across the coils.

$$\frac{12\angle 30^\circ}{(75)(0.064\angle 30^\circ)} = 2.5 \neq \frac{n_1}{n_2} = \frac{2}{5}$$

The transformer voltages don't satisfy the equations describing the ideal transformer. **The given mesh currents are not correct.**

That's enough but let's also check the ratio of coil currents. (Notice that the reference direction of the $i_2(t)$ is different from the reference direction that we used when discussing transformers.)

$$\frac{0.064\angle 30^\circ}{0.0256\angle 30^\circ} = 2.5 \neq \frac{n_1}{n_2} = \frac{2}{5}$$

The transformer currents don't satisfy the equations describing the ideal transformer.

In both case, we calculated $\frac{n_1}{n_2}$ to be 2.5 instead of $0.4 = \frac{1}{2.5}$. This suggests that a data entry error was made while doing the computer analysis. The numbers of turns for the two coils was interchanged.

Design Problems

DP 11.1

$$\left. \begin{array}{l} P=100 \text{ W} \\ pf=0.8 \end{array} \right\} \Rightarrow \left\{ \begin{array}{l} |S| = \frac{P}{pf} = \frac{100}{0.8} = 125 \text{ kVA} \\ Q = |S| \sin(\cos^{-1} 0.8) = 125 \sin(36.9^\circ) = 75 \text{ kVAR} \end{array} \right.$$

(a) Now $pf = 0.95$ so

$$|S| = \frac{P}{pf} = \frac{100}{0.95} = 105.3 \text{ kVA}$$

$$Q = |S| \sin(\cos^{-1} 0.95) = 105.3 \sin(18.2^\circ) = 32.9 \text{ kVAR}$$

so an additional $125 - 105.3 = 19.7 \text{ kVA}$ is available.

(b) Now $pf = 1$ so

$$|S| = \frac{P}{pf} = \frac{100}{1} = 100 \text{ kVA}$$

$$Q = |S| \sin(\cos^{-1} 1) = 0$$

and an additional $125 - 100 = 25 \text{ kVA}$ is available.

(c) In part (a), the capacitors are required to reduce Q by $75 - 32.9 = 42.1 \text{ kVAR}$. In part (b), the capacitors are required to reduce Q by $75 - 0 = 75 \text{ kVAR}$.

(d)

Corrected power factor	0.95	1.0
Additional available apparent power	19.7 kVA	25 kVA
Reduction in reactive power	42.1 kVAR	75 kVAR

DP 11-2

This example demonstrates that loads can be specified either by kW or kVA. The procedure is as follows:

$$\begin{aligned} \text{First load: } \left. \begin{array}{l} |\mathbf{S}_1|=50 \text{ VA} \\ pf=0.9 \end{array} \right\} &\Rightarrow \left\{ \begin{array}{l} P_1=|\mathbf{S}_1| pf=(50)(0.9)=45 \text{ W} \\ Q_1=|\mathbf{S}_1| \sin(\cos^{-1} 0.9)=50 \sin(25.8^\circ)=21.8 \text{ kVAR} \end{array} \right. \\ \text{Second load: } \left. \begin{array}{l} P_2=45 \text{ W} \\ pf=0.91 \end{array} \right\} &\Rightarrow \left\{ \begin{array}{l} |\mathbf{S}_2|=\frac{P_2}{pf}=\frac{45}{0.91}=49.45 \text{ kVA} \\ Q_2=|\mathbf{S}_2| \sin(\cos^{-1} 0.91)=49.45 \sin(24.5^\circ)=20.5 \text{ kVAR} \end{array} \right. \\ \text{Total load: } &\mathbf{S}_L = \mathbf{S}_1 + \mathbf{S}_2 = (45 + 45) + j(21.8 + 20.5) = 90 + j42.3 \text{ kVA} \end{aligned}$$

Specified load:

$$\left. \begin{array}{l} P_s=90 \text{ W} \\ pf=0.97 \end{array} \right\} \Rightarrow \left\{ \begin{array}{l} |\mathbf{S}_s|=\frac{P_s}{pf}=\frac{90}{0.97}=92.8 \text{ kVA} \\ Q_s=|\mathbf{S}_s| \sin(\cos^{-1} 0.97)=92.8 \sin(14.1^\circ)=22.6 \text{ kVAR} \end{array} \right.$$

The compensating capacitive load is $Q_c = 42.3 - 22.6 = 19.7 \text{ kVAR}$.

The required capacitor is calculated as

$$X_c = \frac{|V_c|^2}{Q_c} = \frac{(7.2 \times 10^3)^2}{19.7 \times 10^3} = 2626 \Omega \Rightarrow C = \frac{1}{377 (2626)} = 1.01 \mu\text{F}$$

DP 11-3

Find the open circuit voltage:

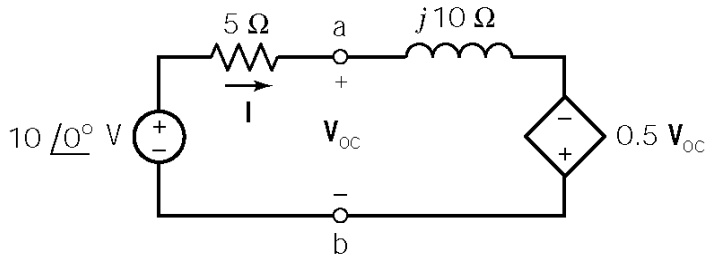

$$-10 + 5\mathbf{I} + j10\mathbf{I} - 0.5\mathbf{V}_{oc} = 0$$

and

$$\mathbf{I} = \frac{10 - \mathbf{V}_{oc}}{5}$$

so

$$\mathbf{V}_{oc} = 8\angle 36.9^\circ = 6.4 + j4.8 \text{ V}$$

Find the short circuit current:

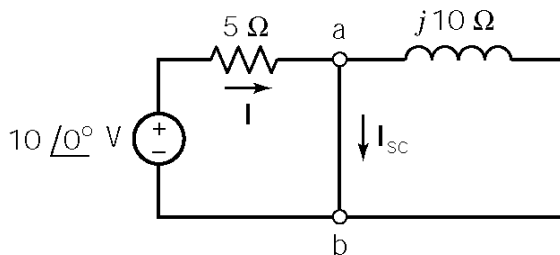

$$\mathbf{I}_{sc} = \frac{10\angle 0^\circ}{5} = 2\angle 0^\circ \text{ A}$$

The the Thevenin impedance is:

$$\mathbf{Z}_t = \frac{\mathbf{V}_{oc}}{\mathbf{I}_{sc}} = 3.2 + j2.4 \Omega$$

The short circuit forces the controlling voltage to be zero. Then the controlled voltage is also zero. Consequently the dependent source has been replaced by a short circuit.

- (a) Maximum power transfer requires $\mathbf{Z}_L = \mathbf{Z}_t^* = 3.2 - j2.4 \Omega$.
- (c) \mathbf{Z}_L can be implemented as the series combination of a resistor and a capacitor with

$$R = 3.2 \Omega \text{ and } C = \frac{1}{(100)(2.4)} = 4.17 \text{ mF.}$$

(b)
$$P_{\max} = \frac{|\mathbf{V}_{oc}|^2}{8R} = \frac{64}{8(3.2)} = 2.5 \text{ W}$$

DP 11-4

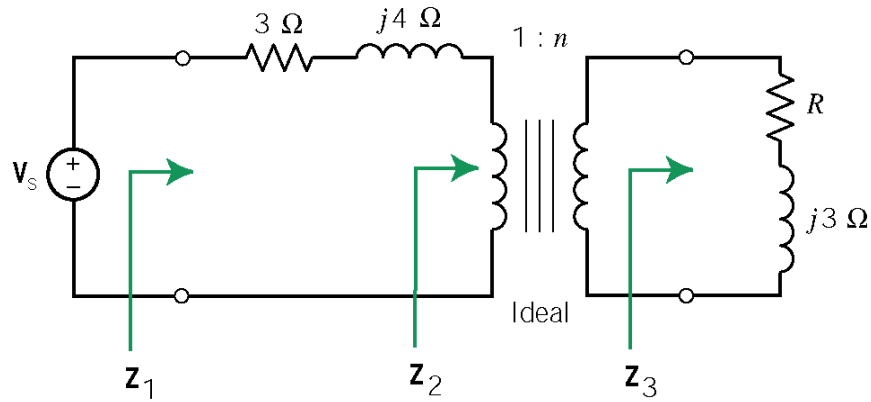

Using an equation from section 11.8, the power is given as

$$P = \frac{\left(\frac{R}{n^2}\right) \frac{|V_s|^2}{2}}{\left(3 + \frac{R}{n^2}\right)^2 + \left(\frac{3}{n^2} + 4\right)^2}$$

When $R = 4 \Omega$,

$$P = \frac{n^2 R |V_s|^2}{25n^4 + 48n^2 + 25}$$

$$0 = \frac{dP}{dn} = R |V_s|^2 \left[\frac{2n(25n^4 + 48n^2 + 25) - n^2(100n^3 + 96n)}{(25n^4 + 48n^2 + 25)^2} \right]$$

$$\Rightarrow -50n^5 + 50n = 0 \Rightarrow n^4 = 1 \Rightarrow n = 1$$

When $R = 8 \Omega$, a similar calculation gives $n = 1.31$.

DP 11-5

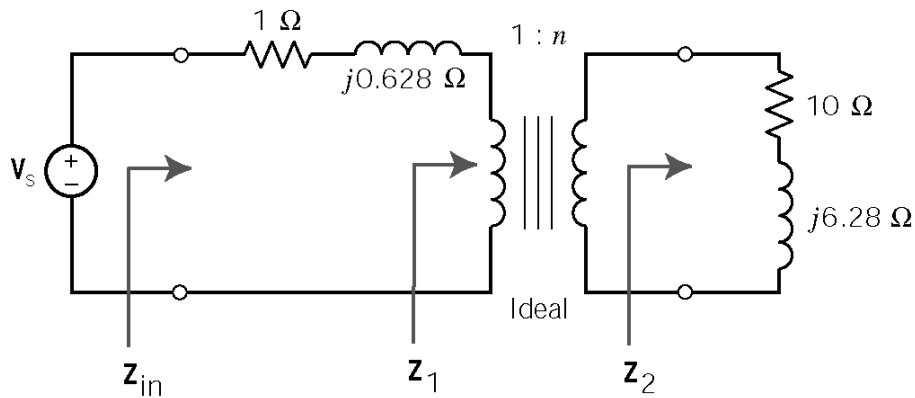

Maximum power transfer requires

$$\frac{10 + j6.28}{n^2} = \mathbf{Z}_1 = (1 + j0.628)^*$$

Equating real parts gives

$$\frac{10}{n^2} = 1 \Rightarrow n = 3.16$$

Equating imaginary parts requires

$$\frac{jX}{3.16^2} = -j0.628 \Rightarrow X = -6.28$$

This reactance can be realized by adding a capacitance C in series with the resistor and inductor that comprise \mathbf{Z}_2 . Then

$$-6.28 = X = -\frac{1}{(2\pi \times 10^5)C} + 6.28 \Rightarrow C = \frac{1}{(2\pi \times 10^5)(12.56)} = 0.1267 \mu F$$

DP 11-6

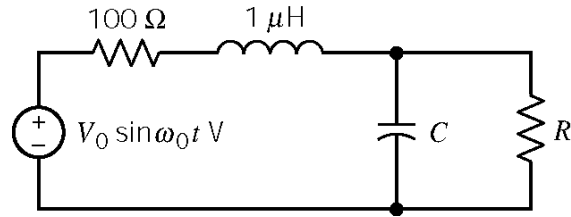

Maximum power transfer requires

$$\frac{1}{j10^7 C} \parallel R = (100 + j10^7 \times 10^{-6})^*$$

$$\frac{R}{1 + j10^7 RC} = 100 - j10$$

$$R = (100 - j10)(1 + j10^7 RC) = 100 + 10^8 RC + j(10^9 RC - 10)$$

Equating real and imaginary parts yields

$$R = 100 + 10^8 RC \quad \text{and} \quad 10^9 RC - 10 = 0$$

then

$$RC = 10^{-8} \Rightarrow R = 100 + 10^8 R \left(\frac{10^{-8}}{R} \right) = 99 \Omega \Rightarrow C = \frac{10^{-8}}{99} = 0.101 \text{ nF}$$

Chapter 12: Three-Phase Circuits

Exercises

Ex. 12.3-1

$$V_C = 120 \angle -240^\circ \quad \text{so} \quad V_A = 120 \angle 0^\circ \quad \text{and} \quad V_B = 120 \angle -120^\circ$$

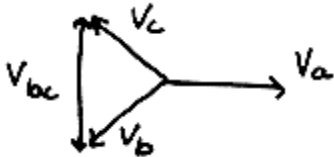

$$V_{bc} = \sqrt{3}(120) \angle -90^\circ$$

Ex. 12.4-1

Four-wire Y-to-Y Circuit

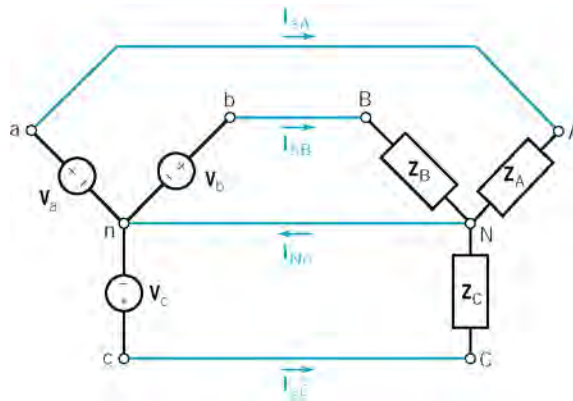

Mathcad analysis (12v4_1.mcd):

Describe the three-phase source: $V_p := 120$

$$V_a := V_p \cdot e^{j \cdot \frac{\pi}{180} \cdot 0}$$

$$V_b := V_a \cdot e^{j \cdot \frac{\pi}{180} \cdot -120}$$

$$V_c := V_a \cdot e^{j \cdot \frac{\pi}{180} \cdot 120}$$

Describe the three-phase load: $Z_A := 80 + j \cdot 50$ $Z_B := 80 + j \cdot 80$ $Z_C := 100 - j \cdot 25$

Calculate the line currents: $I_{aA} := \frac{V_a}{Z_A}$ $I_{bB} := \frac{V_b}{Z_B}$ $I_{cC} := \frac{V_c}{Z_C}$

$$I_{aA} = 1.079 - 0.674i$$

$$I_{bB} = -1.025 - 0.275i$$

$$I_{cC} = -0.809 + 0.837i$$

$$|I_{aA}| = 1.272$$

$$|I_{bB}| = 1.061$$

$$|I_{cC}| = 1.164$$

$$\frac{180}{\pi} \cdot \arg(I_{aA}) = -32.005$$

$$\frac{180}{\pi} \cdot \arg(I_{bB}) = -165$$

$$\frac{180}{\pi} \cdot \arg(I_{cC}) = 134.036$$

Calculate the current in the neutral wire: $I_{Nn} := I_{aA} + I_{bB} + I_{cC}$ $I_{Nn} = -0.755 - 0.112i$

Calculate the power delivered to the load:

$$\begin{aligned} S_A &:= \overline{I_{aA}} \cdot I_{aA} \cdot Z_A & S_B &:= \overline{I_{bB}} \cdot I_{bB} \cdot Z_B & S_C &:= \overline{I_{cC}} \cdot I_{cC} \cdot Z_C \\ S_A &= 129.438 + 80.899i & S_B &= 90 + 90i & S_C &= 135.529 - 33.882i \end{aligned}$$

Total power delivered to the load: $S_A + S_B + S_C = 354.968 + 137.017i$

Calculate the power supplied by the source:

$$\begin{aligned} S_a &:= \overline{I_{aA}} \cdot V_a & S_b &:= \overline{I_{bB}} \cdot V_b & S_c &:= \overline{I_{cC}} \cdot V_c \\ S_a &= 129.438 + 80.899i & S_b &= 90 + 90i & S_c &= 135.529 - 33.882i \end{aligned}$$

Total power delivered by the source: $S_a + S_b + S_c = 354.968 + 137.017i$

Ex. 12.4-2

Four-wire Y-to-Y Circuit

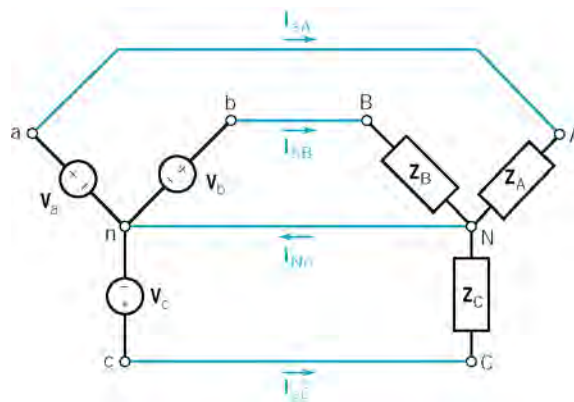

Mathcad analysis (12x4_2.mcd):

Describe the three-phase source: $V_p := 120$

$$\begin{aligned} V_a &:= V_p \cdot e^{j \cdot \frac{\pi}{180} \cdot 0} & V_b &:= V_a \cdot e^{j \cdot \frac{\pi}{180} \cdot -120} & V_c &:= V_a \cdot e^{j \cdot \frac{\pi}{180} \cdot 120} \end{aligned}$$

Describe the three-phase load: $Z_A := 40 + j \cdot 30$ $Z_B := Z_A$ $Z_C := Z_A$

Calculate the line currents: $I_{aA} := \frac{V_a}{Z_A}$ $I_{bB} := \frac{V_b}{Z_B}$ $I_{cC} := \frac{V_c}{Z_C}$

$$\begin{aligned} I_{aA} &= 1.92 - 1.44i & I_{bB} &= -2.207 - 0.943i & I_{cC} &= 0.287 + 2.383i \\ |I_{aA}| &= 2.4 & |I_{bB}| &= 2.4 & |I_{cC}| &= 2.4 \\ \frac{180}{\pi} \cdot \arg(I_{aA}) &= -36.87 & \frac{180}{\pi} \cdot \arg(I_{bB}) &= -156.87 & \frac{180}{\pi} \cdot \arg(I_{cC}) &= 83.13 \end{aligned}$$

Calculate the current in the neutral wire: $I_{Nn} := I_{aA} + I_{bB} + I_{cC}$ $I_{Nn} = 0$

Calculate the power delivered to the load:

$$\begin{aligned} S_A &:= \overline{I_{aA}} \cdot I_{aA} \cdot Z_A & S_B &:= \overline{I_{bB}} \cdot I_{bB} \cdot Z_B & S_C &:= \overline{I_{cC}} \cdot I_{cC} \cdot Z_C \\ S_A &= 230.4 + 172.8i & S_B &= 230.4 + 172.8i & S_C &= 230.4 + 172.8i \end{aligned}$$

Total power delivered to the load: $S_A + S_B + S_C = 691.2 + 518.4i$

Calculate the power supplied by the source:

$$\begin{aligned} S_a &:= \overline{I_{aA}} \cdot V_a & S_b &:= \overline{I_{bB}} \cdot V_b & S_c &:= \overline{I_{cC}} \cdot V_c \\ S_a &= 230.4 + 172.8i & S_b &= 230.4 + 172.8i & S_c &= 230.4 + 172.8i \end{aligned}$$

Total power delivered by the source: $S_a + S_b + S_c = 691.2 + 518.4i$

Ex. 12.4-3

Three-wire unbalanced Y-to-Y Circuit with line impedances

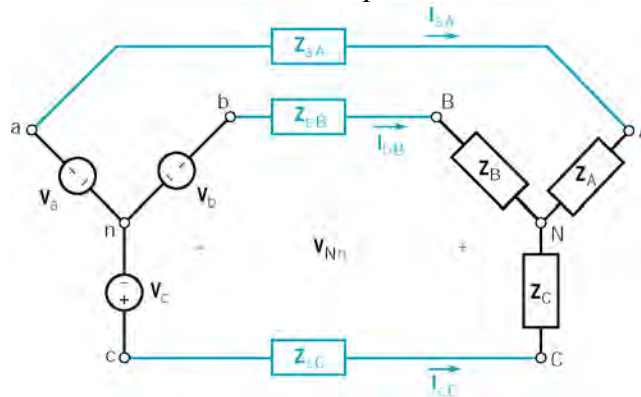

Mathcad analysis (12x4_3.mcd):

Describe the three-phase source: $V_p := 120$

$$\begin{aligned} V_a &:= V_p \cdot e^{j \cdot \frac{\pi}{180} \cdot 0} & V_b &:= V_a \cdot e^{j \cdot \frac{\pi}{180} \cdot -120} & V_c &:= V_a \cdot e^{j \cdot \frac{\pi}{180} \cdot 120} \end{aligned}$$

Describe the three-phase load: $Z_A := 80 + j \cdot 50$ $Z_B := 80 + j \cdot 80$ $Z_C := 100 - j \cdot 25$

Calculate the voltage at the neutral of the load with respect to the neutral of the source:

$$V_{nN} := \frac{Z_A \cdot Z_C \cdot e^{j \cdot \frac{4}{3} \cdot \pi} + Z_A \cdot Z_B \cdot e^{j \cdot \frac{2}{3} \cdot \pi} + Z_B \cdot Z_C}{Z_A \cdot Z_C + Z_A \cdot Z_B + Z_B \cdot Z_C} \cdot V_p$$

$$V_{nN} = -25.137 - 14.236i \quad |V_{nN}| = 28.888 \quad \frac{180}{\pi} \cdot \arg(V_{nN}) = -150.475$$

Calculate the line currents: $I_{aA} := \frac{V_a - V_{nN}}{Z_A}$ $I_{bB} := \frac{V_b - V_{nN}}{Z_B}$ $I_{cC} := \frac{V_c - V_{nN}}{Z_C}$

$I_{aA} = 1.385 - 0.687i$

$I_{bB} = -0.778 - 0.343i$

$I_{cC} = -0.606 + 1.03i$

$|I_{aA}| = 1.546$

$|I_{bB}| = 0.851$

$|I_{cC}| = 1.195$

$\frac{180}{\pi} \cdot \arg(I_{aA}) = -26.403$

$\frac{180}{\pi} \cdot \arg(I_{bB}) = -156.242$

$\frac{180}{\pi} \cdot \arg(I_{cC}) = 120.475$

Check: $I_{aA} + I_{bB} + I_{cC} = 0$

Calculate the power delivered to the load:

$S_A := \overline{I_{aA}} \cdot I_{aA} \cdot Z_A$

$S_B := \overline{I_{bB}} \cdot I_{bB} \cdot Z_B$

$S_C := \overline{I_{cC}} \cdot I_{cC} \cdot Z_C$

$S_A = 191.168 + 119.48i$

$S_B = 57.87 + 57.87i$

$S_C = 142.843 - 35.711i$

Total power delivered to the load: $S_A + S_B + S_C = 391.88 + 141.639i$

Ex. 12.4-4

Three-wire balanced Y-to-Y Circuit with line impedances

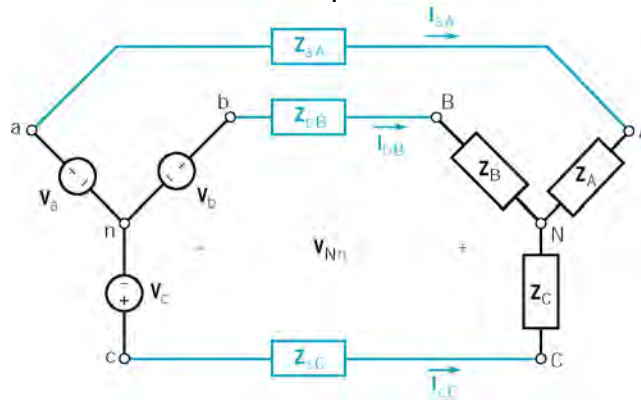

Mathcad analysis (12x4_4.mcd):

Describe the three-phase source: $V_p := 120$

$V_a := V_p \cdot e^{j \cdot \frac{\pi}{180} \cdot 0}$

$V_b := V_a \cdot e^{j \cdot \frac{\pi}{180} \cdot -120}$

$V_c := V_a \cdot e^{j \cdot \frac{\pi}{180} \cdot 120}$

Describe the three-phase load: $Z_A := 40 + j \cdot 30$ $Z_B := Z_A$ $Z_C := Z_A$

Calculate the voltage at the neutral of the load with respect to the neutral of the source:

$$V_{nN} := \frac{Z_A \cdot Z_C \cdot e^{j \cdot \frac{4}{3} \cdot \pi} + Z_A \cdot Z_B \cdot e^{j \cdot \frac{2}{3} \cdot \pi} + Z_B \cdot Z_C}{Z_A \cdot Z_C + Z_A \cdot Z_B + Z_B \cdot Z_C} \cdot V_p$$

$$V_{nN} = -1.31 \times 10^{-14} + 1.892i \times 10^{-14} \quad |V_{nN}| = 2.301 \times 10^{-14} \quad \frac{180}{\pi} \cdot \arg(V_{nN}) = 124.695$$

Calculate the line currents: $I_{aA} := \frac{V_a - V_{nN}}{Z_A} \quad I_{bB} := \frac{V_b - V_{nN}}{Z_B} \quad I_{cC} := \frac{V_c - V_{nN}}{Z_C}$

$$I_{aA} = 1.92 - 1.44i$$

$$I_{bB} = -2.207 - 0.943i$$

$$I_{cC} = 0.287 + 2.383i$$

$$|I_{aA}| = 2.4$$

$$|I_{bB}| = 2.4$$

$$|I_{cC}| = 2.4$$

$$\frac{180}{\pi} \cdot \arg(I_{aA}) = -36.87$$

$$\frac{180}{\pi} \cdot \arg(I_{bB}) = -156.87$$

$$\frac{180}{\pi} \cdot \arg(I_{cC}) = 83.13$$

Check: $I_{aA} + I_{bB} + I_{cC} = 1.055 \times 10^{-15} - 2.22i \times 10^{-15}$

Calculate the power delivered to the load:

$$S_A := \overline{I_{aA}} \cdot I_{aA} \cdot Z_A$$

$$S_B := \overline{I_{bB}} \cdot I_{bB} \cdot Z_B$$

$$S_C := \overline{I_{cC}} \cdot I_{cC} \cdot Z_C$$

$$S_A = 230.4 + 172.8i$$

$$S_B = 230.4 + 172.8i$$

$$S_C = 230.4 + 172.8i$$

Total power delivered to the load: $S_A + S_B + S_C = 691.2 + 518.4i$

Ex. 12.6-1

Balanced delta load:

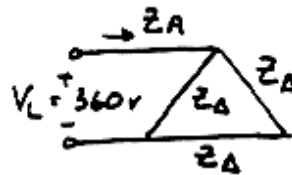

(See Table 12.5-1)

$$Z_{\Delta} = 180 \angle -45^{\circ}$$

phase currents:

$$I_{AB} = \frac{V_{AB}}{Z_{\Delta}} = \frac{360 \angle 0^{\circ}}{180 \angle -45^{\circ}} = 2 \angle 45^{\circ} \text{ A}$$

$$I_{BC} = \frac{V_{BC}}{Z_{\Delta}} = \frac{360 \angle -120^{\circ}}{180 \angle -45^{\circ}} = 2 \angle -75^{\circ} \text{ A}$$

$$I_{CA} = \frac{V_{CA}}{Z_{\Delta}} = \frac{360 \angle 120^{\circ}}{180 \angle -45^{\circ}} = 2 \angle 165^{\circ} \text{ A}$$

line currents:

$$I_A = I_{AB} - I_{CA} = 2 \angle 45^{\circ} - 2 \angle 165^{\circ} = 2\sqrt{3} \angle 15^{\circ} \text{ A}$$

$$I_B = 2\sqrt{3} \angle -105^{\circ} \text{ A}$$

$$I_C = 2\sqrt{3} \angle 135^{\circ} \text{ A}$$

Ex. 12.7-1

Three-wire Y-to-Delta Circuit with line impedances

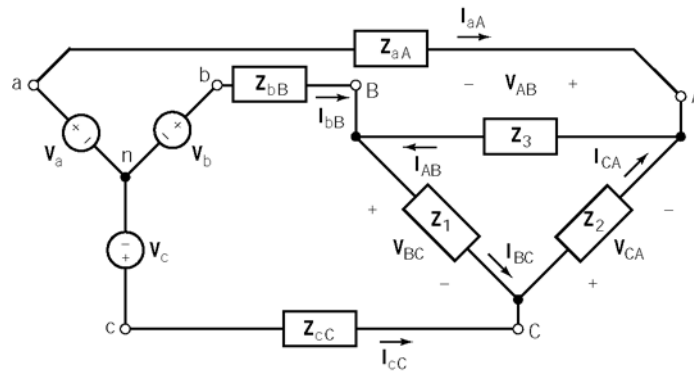

Mathcad analysis (12x4_4.mcd):

Describe the three-phase source: $V_p := 110$

$$V_a := V_p \cdot e^{j \cdot \frac{\pi}{180} \cdot 0} \quad V_b := V_a \cdot e^{j \cdot \frac{\pi}{180} \cdot -120} \quad V_c := V_a \cdot e^{j \cdot \frac{\pi}{180} \cdot 120}$$

Describe the delta connected load: $Z_1 := 150 + j \cdot 270$ $Z_2 := Z_1$ $Z_3 := Z_1$

Convert the delta connected load to the equivalent Y connected load:

$$Z_A := \frac{Z_1 \cdot Z_3}{Z_1 + Z_2 + Z_3} \quad Z_B := \frac{Z_2 \cdot Z_3}{Z_1 + Z_2 + Z_3} \quad Z_C := \frac{Z_1 \cdot Z_2}{Z_1 + Z_2 + Z_3}$$

$$Z_A = 50 + 90i \quad Z_B = 50 + 90i \quad Z_C = 50 + 90i$$

Describe the three-phase line: $Z_{aA} := 10 + j \cdot 25$ $Z_{bB} := Z_{aA}$ $Z_{cC} := Z_{aA}$

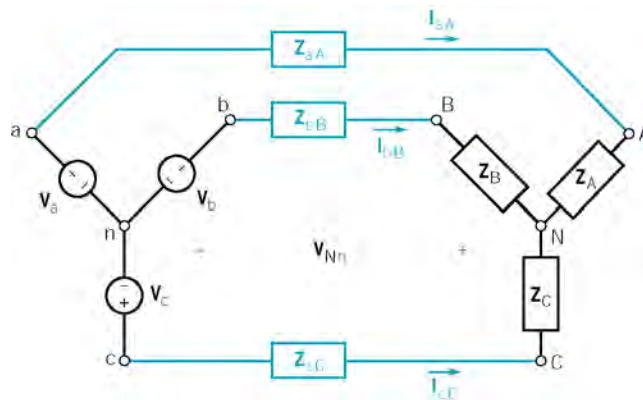

Calculate the voltage at the neutral of the load with respect to the neutral of the source:

$$V_{nN} := \frac{(Z_{aA} + Z_A) \cdot (Z_{cC} + Z_C) \cdot e^{j \cdot \frac{4}{3} \cdot \pi} + (Z_{aA} + Z_A) \cdot (Z_{bB} + Z_B) \cdot e^{j \cdot \frac{2}{3} \cdot \pi} + (Z_{bB} + Z_B) \cdot (Z_{cC} + Z_C)}{(Z_{aA} + Z_A) \cdot (Z_{cC} + Z_C) + (Z_{aA} + Z_A) \cdot (Z_{bB} + Z_B) + (Z_{bB} + Z_B) \cdot (Z_{cC} + Z_C)} \cdot V_p$$

$$V_{nN} = -1.172 \times 10^{-14} + 1.784i \times 10^{-14} \quad |V_{nN}| = 2.135 \times 10^{-14} \quad \frac{180}{\pi} \cdot \arg(V_{nN}) = 123.304$$

Calculate the line currents: $I_{aA} := \frac{V_a - V_{nN}}{Z_A + Z_{aA}} \quad I_{bB} := \frac{V_b - V_{nN}}{Z_B + Z_{bB}} \quad I_{cC} := \frac{V_c - V_{nN}}{Z_C + Z_{cC}}$

$$I_{aA} = 0.392 - 0.752i$$

$$I_{bB} = -0.847 + 0.036i$$

$$I_{cC} = 0.455 + 0.716i$$

$$|I_{aA}| = 0.848$$

$$|I_{bB}| = 0.848$$

$$|I_{cC}| = 0.848$$

$$\frac{180}{\pi} \cdot \arg(I_{aA}) = -62.447$$

$$\frac{180}{\pi} \cdot \arg(I_{bB}) = 177.553$$

$$\frac{180}{\pi} \cdot \arg(I_{cC}) = 57.553$$

Check: $I_{aA} + I_{bB} + I_{cC} = 0$

Calculate the phase voltages of the Y-connected load:

$$V_{AN} := I_{aA} \cdot Z_A$$

$$V_{BN} := I_{bB} \cdot Z_B$$

$$V_{CN} := I_{cC} \cdot Z_C$$

$$|V_{AN}| = 87.311$$

$$|V_{BN}| = 87.311$$

$$|V_{CN}| = 87.311$$

$$\frac{180}{\pi} \cdot \arg(V_{AN}) = -1.502$$

$$\frac{180}{\pi} \cdot \arg(V_{BN}) = -121.502$$

$$\frac{180}{\pi} \cdot \arg(V_{CN}) = 118.498$$

Calculate the line-to-line voltages at the load:

$$V_{AB} := V_{AN} - V_{BN}$$

$$V_{BC} := V_{BN} - V_{CN}$$

$$V_{CA} := V_{CN} - V_{AN}$$

$$|V_{AB}| = 151.227$$

$$|V_{BC}| = 151.227$$

$$|V_{CA}| = 151.227$$

$$\frac{180}{\pi} \cdot \arg(V_{AB}) = 28.498$$

$$\frac{180}{\pi} \cdot \arg(V_{BC}) = -91.502$$

$$\frac{180}{\pi} \cdot \arg(V_{CA}) = 148.498$$

Calculate the phase currents of the Δ -connected load:

$$I_{AB} := \frac{V_{AB}}{Z_3}$$

$$I_{BC} := \frac{V_{BC}}{Z_1}$$

$$I_{CA} := \frac{V_{CA}}{Z_2}$$

$$|I_{AB}| = 0.49$$

$$|I_{BC}| = 0.49$$

$$|I_{CA}| = 0.49$$

$$\frac{180}{\pi} \cdot \arg(I_{AB}) = -32.447$$

$$\frac{180}{\pi} \cdot \arg(I_{BC}) = -152.447$$

$$\frac{180}{\pi} \cdot \arg(I_{CA}) = 87.553$$

Ex. 12.8-1

Continuing Ex. 12.8-1:

Calculate the power delivered to the load:

$$S_A := \overline{I_a A} \cdot I_a A \cdot Z_A$$

$$S_A = 35.958 + 64.725i$$

$$S_B := \overline{I_b B} \cdot I_b B \cdot Z_B$$

$$S_B = 35.958 + 64.725i$$

$$S_C := \overline{I_c C} \cdot I_c C \cdot Z_C$$

$$S_C = 35.958 + 64.725i$$

$$\text{Total power delivered to the load: } S_A + S_B + S_C = 107.875 + 194.175i$$

Ex. 12.9-1

$$P_1 = V_{AB} I_A \cos(\theta + 30^\circ) + V_{CB} I_C \cos(\theta - 30^\circ) = P_1 + P_2$$

$$pf = .4 \text{ lagging} \Rightarrow \theta = 61.97^\circ$$

$$\text{So } P_T = 450(24) [\cos 91.97^\circ + \cos 31.97^\circ] = 8791 \text{ W}$$

$$\therefore P_1 = -371 \text{ W} \quad P_2 = 9162 \text{ W}$$

Ex. 12.9-2Consider Fig. 12.9-1 with $P_1 = 60 \text{ kW}$ $P_2 = 40 \text{ kW}$.

$$(a.) P = P_1 + P_2 = 100 \text{ kW}$$

(b.) use equation 12.9-7 to get

$$\tan \theta = \sqrt{3} \frac{P_2 - P_1}{P_L + P_2} = \sqrt{3} \frac{40 - 60}{100} = -.346 \Rightarrow \theta = -19.11^\circ$$

then

$$pf = \cos(-19.110^\circ) = \underline{0.945} \text{ leading}$$

Problems

Section 12-3: Three Phase Voltages

P12.3-1

Given $V_C = 277 \angle 45^\circ$ and an *abc* phase sequence:

$$V_A = 277 \angle (45 - 120)^\circ = 277 \angle -75^\circ$$

$$V_B = 277 \angle (45^\circ + 120)^\circ = 277 \angle 165^\circ$$

$$\begin{aligned} V_{AB} &= V_A - V_B = (277 \angle -75^\circ) - (277 \angle 165^\circ) \\ &= (71.69 - j267.56) - (-267.56 + j71.69) \\ &= 339.25 - j339.25 = 479.77 \angle -45^\circ \approx 480 \angle -45^\circ \end{aligned}$$

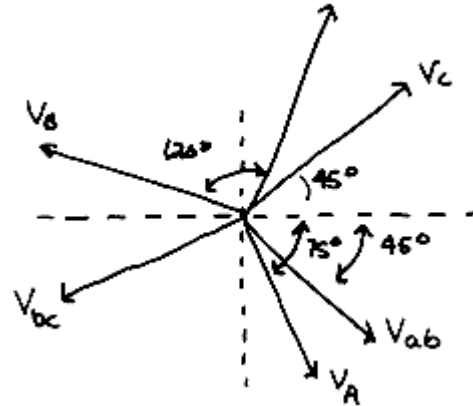

Similarly:

$$V_{BC} = 480 \angle -165^\circ \text{ and } V_{CA} = 480 \angle 75^\circ$$

P12.3-2

$$V_{AB} = V_A \times \sqrt{3} \angle 30^\circ \Rightarrow V_A = \frac{V_{AB}}{\sqrt{3} \angle 30^\circ}$$

In our case: $V_{AB} = -V_{BA} = -(12470 \angle -35^\circ) = 12470 \angle 145^\circ \text{ V}$

$$\text{So } V_A = \frac{12470 \angle 145^\circ}{\sqrt{3} \angle 30^\circ} = 7200 \angle 115^\circ$$

Then, for an *abc* phase sequence:

$$V_C = 7200 \angle (115 + 120)^\circ = 7200 \angle 235^\circ = 7200 \angle -125^\circ$$

$$V_B = 7200 \angle (115 - 120)^\circ = 7200 \angle -5^\circ \text{ V}$$

P12.3-3

$$V_{ab} = V_a \times \sqrt{3} \angle 30^\circ \Rightarrow V_a = \frac{V_{ab}}{\sqrt{3} \angle 30^\circ}$$

In our case, the line-to-line voltage is

$$V_{ab} = 1500 \angle 30^\circ \text{ V}$$

$$\text{So the phase voltage is } V_a = \frac{1500 \angle 30^\circ}{\sqrt{3} \angle 30^\circ} = 866 \angle 0^\circ \text{ V}$$

Section 12-4: The Y-to-Y Circuit

P12.4-1

Balanced, three-wire, Y-Y circuit:

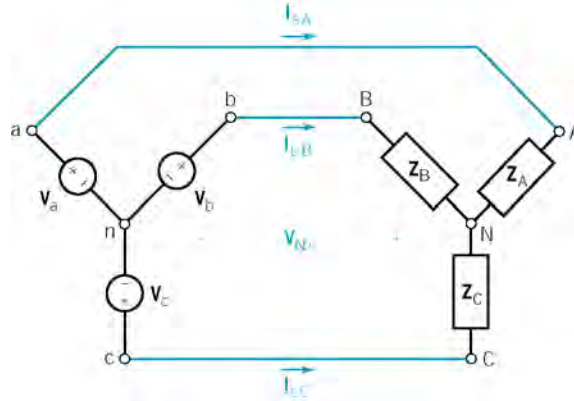

where $Z_A = Z_B = Z_C = 12\angle 30^\circ = 10.4 + j6$

MathCAD analysis (12p4_1.mcd):

Describe the three-phase source: $V_p := \frac{208}{\sqrt{3}}$

$$V_a := V_p \cdot e^{j \cdot \frac{\pi}{180} \cdot 0} \quad V_b := V_a \cdot e^{j \cdot \frac{\pi}{180} \cdot -120} \quad V_c := V_a \cdot e^{j \cdot \frac{\pi}{180} \cdot 120}$$

Describe the balanced three-phase load: $Z_A := 10.4 + j \cdot 6 \quad Z_B := Z_A \quad Z_C := Z_B$

Check: The voltage at the neutral of the load with respect to the neutral of the source should be zero:

$$V_{nN} := \frac{Z_A \cdot Z_C \cdot e^{j \cdot \frac{4}{3} \cdot \pi} + Z_A \cdot Z_B \cdot e^{j \cdot \frac{2}{3} \cdot \pi} + Z_B \cdot Z_C}{Z_A \cdot Z_C + Z_A \cdot Z_B + Z_B \cdot Z_C} \cdot V_p \quad |V_{nN}| = 2.762 \times 10^{-14}$$

Calculate the line currents: $I_{aA} := \frac{V_a - V_{nN}}{Z_A} \quad I_{bB} := \frac{V_b - V_{nN}}{Z_B} \quad I_{cC} := \frac{V_c - V_{nN}}{Z_C}$

$$I_{aA} = 8.663 - 4.998i \quad I_{bB} = -8.66 - 5.004i \quad I_{cC} = -3.205 \times 10^{-3} + 10.002i$$

$$|I_{aA}| = 10.002 \quad |I_{bB}| = 10.002 \quad |I_{cC}| = 10.002$$

$$\frac{180}{\pi} \cdot \arg(I_{aA}) = -29.982 \quad \frac{180}{\pi} \cdot \arg(I_{bB}) = -149.982 \quad \frac{180}{\pi} \cdot \arg(I_{cC}) = 90.018$$

Check: $I_{aA} + I_{bB} + I_{cC} = 4.696 \times 10^{-15} - 1.066i \times 10^{-14}$

Calculate the power delivered to the load:

$$\begin{aligned}
 S_A &:= \overline{I_{aA}} \cdot I_{aA} \cdot Z_A & S_B &:= \overline{I_{bB}} \cdot I_{bB} \cdot Z_B & S_C &:= \overline{I_{cC}} \cdot I_{cC} \cdot Z_C \\
 S_A &= 1.04 \times 10^3 + 600.222i & S_B &= 1.04 \times 10^3 + 600.222i & S_C &= 1.04 \times 10^3 + 600.222i
 \end{aligned}$$

Total power delivered to the load: $S_A + S_B + S_C = 3.121 \times 10^3 + 1.801i \times 10^3$

Consequently:

(a) The phase voltages are

$$\mathbf{V}_a = \frac{208}{\sqrt{3}} \angle 0^\circ = 120 \angle 0^\circ \text{ V rms}, \quad \mathbf{V}_b = 120 \angle -120^\circ \text{ V rms} \text{ and } \mathbf{V}_c = 120 \angle 120^\circ \text{ V rms}$$

(b) The currents are equal the line currents

$$\mathbf{I}_a = \mathbf{I}_{aA} = 10 \angle -30^\circ \text{ A rms}, \quad \mathbf{I}_b = \mathbf{I}_{bB} = 10 \angle -150^\circ \text{ A rms}$$

and

$$\mathbf{I}_c = \mathbf{I}_{cC} = 10 \angle 90^\circ \text{ A rms}$$

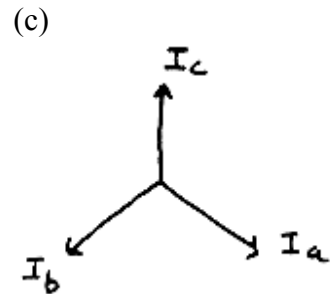

(d) The power delivered to the load is $\mathbf{S} = 3.121 + j1.801 \text{ kVA}$.

P12.4-2

Balanced, three-wire, Y-Y circuit:

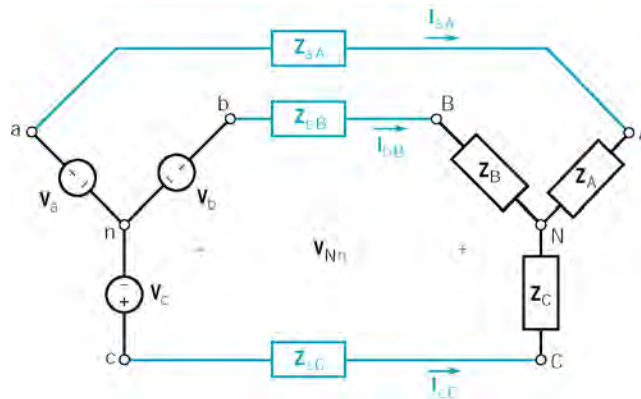

where

$$\mathbf{V}_a = 120 \angle 0^\circ \text{ Vrms}, \quad \mathbf{V}_b = 120 \angle -120^\circ \text{ Vrms} \text{ and } \mathbf{V}_c = 120 \angle 120^\circ \text{ Vrms}$$

$$\mathbf{Z}_A = \mathbf{Z}_B = \mathbf{Z}_C = 10 + j(2 \times \pi \times 60)(100 \times 10^{-3}) = 10 + j37.7 \ \Omega$$

and

$$\mathbf{Z}_{aA} = \mathbf{Z}_{bB} = \mathbf{Z}_{cC} = 2 \ \Omega$$

Mathcad Analysis (12p4_2.mcd):

Describe the three-phase source: $V_p := 120$

$$V_a := V_p \cdot e^{j \cdot \frac{\pi}{180} \cdot 0} \quad V_b := V_a \cdot e^{j \cdot \frac{\pi}{180} \cdot -120} \quad V_c := V_a \cdot e^{j \cdot \frac{\pi}{180} \cdot 120}$$

Describe the three-phase load: $Z_A := 10 + j \cdot 37.7$ $Z_B := Z_A$ $Z_C := Z_B$

Describe the three-phase line: $Z_{aA} := 2$ $Z_{bB} := Z_{aA}$ $Z_{cC} := Z_{aA}$

Calculate the voltage at the neutral of the load with respect to the neutral of the source:

$$V_{nN} := \frac{(Z_{aA} + Z_A) \cdot (Z_{cC} + Z_C) \cdot e^{j \cdot \frac{4}{3} \cdot \pi} + (Z_{aA} + Z_A) \cdot (Z_{bB} + Z_B) \cdot e^{j \cdot \frac{2}{3} \cdot \pi} + (Z_{bB} + Z_B) \cdot (Z_{cC} + Z_C)}{(Z_{aA} + Z_A) \cdot (Z_{cC} + Z_C) + (Z_{aA} + Z_A) \cdot (Z_{bB} + Z_B) + (Z_{bB} + Z_B) \cdot (Z_{cC} + Z_C)} \cdot V_F$$

$$V_{nN} = -8.693 \times 10^{-15} + 2.232i \times 10^{-14} \quad |V_{nN}| = 2.396 \times 10^{-14} \quad \frac{180}{\pi} \cdot \arg(V_{nN}) = 111.277$$

Calculate the line currents: $I_{aA} := \frac{V_a - V_{nN}}{Z_A + Z_{aA}}$ $I_{bB} := \frac{V_b - V_{nN}}{Z_B + Z_{bB}}$ $I_{cC} := \frac{V_c - V_{nN}}{Z_C + Z_{cC}}$

$$I_{aA} = 0.92 - 2.89i$$

$$I_{bB} = -2.963 + 0.648i$$

$$I_{cC} = 2.043 + 2.242i$$

$$|I_{aA}| = 3.033$$

$$|I_{bB}| = 3.033$$

$$|I_{cC}| = 3.033$$

$$\frac{180}{\pi} \cdot \arg(I_{aA}) = -72.344$$

$$\frac{180}{\pi} \cdot \arg(I_{bB}) = 167.656$$

$$\frac{180}{\pi} \cdot \arg(I_{cC}) = 47.656$$

Check: $I_{aA} + I_{bB} + I_{cC} = -1.332 \times 10^{-15} - 3.109i \times 10^{-15}$

Calculate the phase voltages at the load: $V_A := Z_A \cdot I_{aA}$ $V_B := Z_B \cdot I_{bB}$ $V_C := Z_C \cdot I_{cC}$

$$|V_A| = 118.301$$

$$|V_B| = 118.301$$

$$|V_C| = 118.301$$

$$\frac{180}{\pi} \cdot \arg(V_A) = 2.801$$

$$\frac{180}{\pi} \cdot \arg(V_B) = -117.199$$

$$\frac{180}{\pi} \cdot \arg(V_C) = 122.801$$

Consequently, the line-to-line voltages at the source are:

$$\begin{aligned} V_{ab} &= V_a \times \sqrt{3} \angle 30^\circ = 120 \angle 0^\circ \times \sqrt{3} \angle 30^\circ = 208 \angle 30^\circ \text{ Vrms,} \\ V_{bc} &= 208 \angle -120^\circ \text{ Vrms and } V_{ca} = 208 \angle 120^\circ \text{ Vrms} \end{aligned}$$

The line-to-line voltages at the load are:

$$\begin{aligned} V_{AB} &= V_A \times \sqrt{3} \angle 30^\circ = 118.3 \angle 3^\circ \times \sqrt{3} \angle 30^\circ = 205 \angle 33^\circ \text{ Vrms,} \\ V_{bc} &= 205 \angle -117^\circ \text{ Vrms and } V_{ca} = 205 \angle 123^\circ \text{ Vrms} \end{aligned}$$

and the phase currents are

$$I_a = I_{aA} = 10 \angle -72^\circ \text{ A rms, } I_b = I_{bB} = 3 \angle 168^\circ \text{ A rms and } I_c = I_{cC} = 3 \angle 48^\circ \text{ A rms}$$

P12.4-3

Balanced, three-wire, Y-Y circuit:

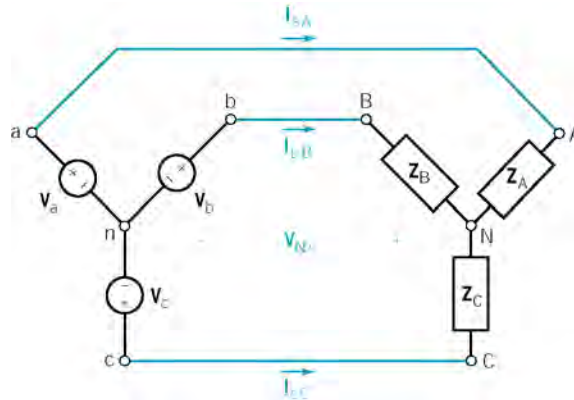

where

$V_a = 10\angle 0^\circ \text{ V} = 7.07\angle 0^\circ \text{ V rms}$, $V_b = 7.07\angle -120^\circ \text{ V rms}$ and $V_c = 7.07\angle 120^\circ \text{ V rms}$
and

$$Z_A = Z_B = Z_C = 12 + j(16)(1) = 12 + j16 \ \Omega$$

MathCAD analysis (12p4_3.mcd):

Describe the three-phase source: $V_p := \frac{10}{\sqrt{2}}$

$$V_a := V_p \cdot e^{j \cdot \frac{\pi}{180} \cdot 0} \quad V_b := V_a \cdot e^{j \cdot \frac{\pi}{180} \cdot -120} \quad V_c := V_a \cdot e^{j \cdot \frac{\pi}{180} \cdot 120}$$

Describe the balanced three-phase load: $Z_A := 12 + j \cdot 16 \quad Z_B := Z_A \quad Z_C := Z_B$

Check: The voltage at the neutral of the load with respect to the neutral of the source should be zero:

$$V_{nN} := \frac{Z_A \cdot Z_C \cdot e^{j \cdot \frac{4}{3} \cdot \pi} + Z_A \cdot Z_B \cdot e^{j \cdot \frac{2}{3} \cdot \pi} + Z_B \cdot Z_C}{Z_A \cdot Z_C + Z_A \cdot Z_B + Z_B \cdot Z_C} \cdot V_p \quad |V_{nN}| = 1.675 \times 10^{-15}$$

Calculate the line currents: $I_{aA} := \frac{V_a - V_{nN}}{Z_A} \quad I_{bB} := \frac{V_b - V_{nN}}{Z_B} \quad I_{cC} := \frac{V_c - V_{nN}}{Z_C}$

$$I_{aA} = 0.212 - 0.283i$$

$$I_{bB} = -0.351 - 0.042i$$

$$I_{cC} = 0.139 + 0.325i$$

$$|I_{aA}| = 0.354$$

$$|I_{bB}| = 0.354$$

$$|I_{cC}| = 0.354$$

$$\frac{180}{\pi} \cdot \arg(I_{aA}) = -53.13$$

$$\frac{180}{\pi} \cdot \arg(I_{bB}) = -173.13$$

$$\frac{180}{\pi} \cdot \arg(I_{cC}) = 66.87$$

Calculate the power delivered to the load:

$$S_A := \overline{I_{aA}} \cdot I_{aA} \cdot Z_A$$

$$S_B := \overline{I_{bB}} \cdot I_{bB} \cdot Z_B$$

$$S_C := \overline{I_{cC}} \cdot I_{cC} \cdot Z_C$$

$$S_A = 1.5 + 2i$$

$$S_B = 1.5 + 2i$$

$$S_C = 1.5 + 2i$$

Total power delivered to the load: $S_A + S_B + S_C = 4.5 + 6i$

Consequently

(a) The rms value of $i_a(t)$ is 0.354 A rms.

(b) The average power delivered to the load is $P = \text{Re}\{S\} = \text{Re}\{4.5 + j6\} = 4.5 \text{ W}$

P12.4-4

Unbalanced, three-wire, Y-Y circuit:

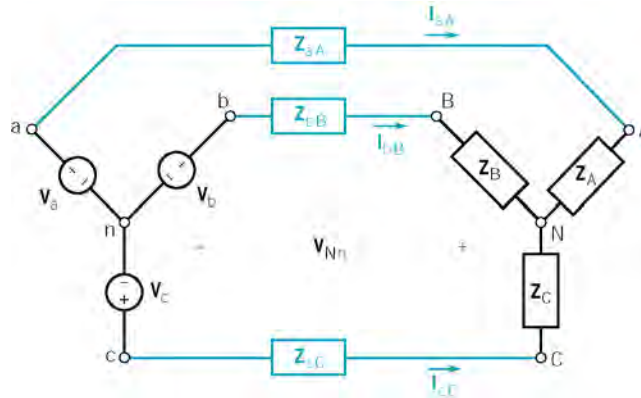

where

$$\mathbf{V}_a = 100\angle 0^\circ \text{ V} = 70.7\angle 0^\circ \text{ V rms}, \quad \mathbf{V}_b = 70.7\angle -120^\circ \text{ V rms} \text{ and } \mathbf{V}_c = 70.7\angle 120^\circ \text{ V rms}$$

$$\mathbf{Z}_A = 20 + j(377)(60 \times 10^{-3}) = 20 + j 22.6 \ \Omega, \quad \mathbf{Z}_B = 40 + j(377)(40 \times 10^{-3}) = 40 + j 15.1 \ \Omega$$

$$\mathbf{Z}_C = 60 + j(377)(20 \times 10^{-3}) = 60 + j 7.54 \ \Omega$$

and

$$\mathbf{Z}_{aA} = \mathbf{Z}_{bB} = \mathbf{Z}_{cC} = 10 + j(377)(5 \times 10^{-3}) = 10 + j 1.89 \ \Omega$$

Mathcad Analysis (12p4_4.mcd):

Describe the three-phase source: $V_p := 100$

$$V_a := V_p \cdot e^{j \cdot \frac{\pi}{180} \cdot 0} \quad V_b := V_a \cdot e^{j \cdot \frac{\pi}{180} \cdot 120} \quad V_c := V_a \cdot e^{j \cdot \frac{\pi}{180} \cdot -120}$$

Enter the frequency of the 3-phase source: $\omega := 377$

Describe the three-phase load: $Z_A := 20 + j \cdot \omega \cdot 0.06 \quad Z_B := 40 + j \cdot \omega \cdot 0.04 \quad Z_C := 60 + j \cdot \omega \cdot 0.02$

Describe the three-phase line: $Z_{aA} := 10 + j \cdot \omega \cdot 0.005 \quad Z_{bB} := Z_{aA} \quad Z_{cC} := Z_{aA}$

Calculate the voltage at the neutral of the load with respect to the neutral of the source:

$$V_{nN} := \frac{(Z_{aA} + Z_A) \cdot (Z_{cC} + Z_C) \cdot e^{j \cdot \frac{4}{3} \cdot \pi} + (Z_{aA} + Z_A) \cdot (Z_{bB} + Z_B) \cdot e^{j \cdot \frac{2}{3} \cdot \pi} + (Z_{bB} + Z_B) \cdot (Z_{cC} + Z_C)}{(Z_{aA} + Z_A) \cdot (Z_{cC} + Z_C) + (Z_{aA} + Z_A) \cdot (Z_{bB} + Z_B) + (Z_{bB} + Z_B) \cdot (Z_{cC} + Z_C)} \cdot V_F$$

$$V_{nN} = 12.209 - 24.552i \quad |V_{nN}| = 27.42 \quad \frac{180}{\pi} \cdot \arg(V_{nN}) = -63.561$$

Calculate the line currents: $I_{aA} := \frac{V_a - V_{nN}}{Z_A + Z_{aA}} \quad I_{bB} := \frac{V_b - V_{nN}}{Z_B + Z_{bB}} \quad I_{cC} := \frac{V_c - V_{nN}}{Z_C + Z_{cC}}$

$$I_{aA} = 2.156 - 0.943i$$

$$I_{bB} = -0.439 + 2.372i$$

$$I_{cC} = -0.99 - 0.753i$$

$$|I_{aA}| = 2.353$$

$$|I_{bB}| = 2.412$$

$$|I_{cC}| = 1.244$$

$$\frac{180}{\pi} \cdot \arg(I_{aA}) = -23.619$$

$$\frac{180}{\pi} \cdot \arg(I_{bB}) = 100.492$$

$$\frac{180}{\pi} \cdot \arg(I_{cC}) = -142.741$$

Calculate the power delivered to the load:

$$S_A := \frac{(\overline{I_{aA}} \cdot I_{aA})}{2} \cdot Z_A$$

$$S_B := \frac{(\overline{I_{bB}} \cdot I_{bB})}{2} \cdot Z_B$$

$$S_C := \frac{(\overline{I_{cC}} \cdot I_{cC})}{2} \cdot Z_C$$

$$S_A = 55.382 + 62.637i$$

$$S_B = 116.402 + 43.884i$$

$$S_C = 46.425 + 5.834i$$

Total power delivered to the load: $S_A + S_B + S_C = 218.209 + 112.355i$

The average power delivered to the load is $P = \text{Re}\{S\} = \text{Re}\{218.2 + j112.4\} = 218.2 \text{ W}$

P12.4-5

Balanced, three-wire, Y-Y circuit:

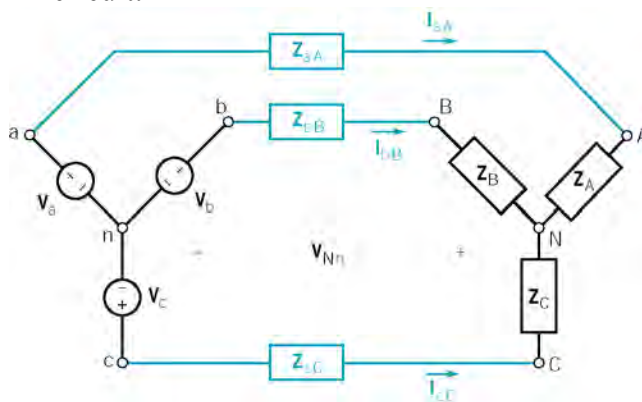

where

$$V_a = 100 \angle 0^\circ \text{ V} = 70.7 \angle 0^\circ \text{ V rms}, \quad V_b = 70.7 \angle -120^\circ \text{ V rms} \quad \text{and} \quad V_c = 70.7 \angle 120^\circ \text{ V rms}$$

$$Z_A = Z_B = Z_C = 20 + j(377)(60 \times 10^{-3}) = 20 + j22.6 \ \Omega$$

and

$$Z_{aA} = Z_{bB} = Z_{cC} = 10 + j(377)(5 \times 10^{-3}) = 10 + j1.89 \ \Omega$$

Mathcad Analysis (12p4_5.mcd):

Describe the three-phase source: $V_p := 100$

$$V_a := V_p \cdot e^{j \cdot \frac{\pi}{180} \cdot 0} \quad V_b := V_a \cdot e^{j \cdot \frac{\pi}{180} \cdot 120} \quad V_c := V_a \cdot e^{j \cdot \frac{\pi}{180} \cdot -120}$$

Enter the frequency of the 3-phase source: $\omega := 377$

Describe the three-phase load: $Z_A := 20 + j \cdot \omega \cdot 0.06$ $Z_B := Z_A$ $Z_C := Z_A$

Describe the three-phase line: $Z_{aA} := 10 + j \cdot \omega \cdot 0.005$ $Z_{bB} := Z_{aA}$ $Z_{cC} := Z_{aA}$

Calculate the voltage at the neutral of the load with respect to the neutral of the source:

$$V_{nN} := \frac{(Z_{aA} + Z_A) \cdot (Z_{cC} + Z_C) \cdot e^{j \cdot \frac{4}{3} \cdot \pi} + (Z_{aA} + Z_A) \cdot (Z_{bB} + Z_B) \cdot e^{j \cdot \frac{2}{3} \cdot \pi} + (Z_{bB} + Z_B) \cdot (Z_{cC} + Z_C)}{(Z_{aA} + Z_A) \cdot (Z_{cC} + Z_C) + (Z_{aA} + Z_A) \cdot (Z_{bB} + Z_B) + (Z_{bB} + Z_B) \cdot (Z_{cC} + Z_C)} \cdot V_F$$

$$V_{nN} = -8.982 \times 10^{-15} + 1.879i \times 10^{-14} \quad |V_{nN}| = 2.083 \times 10^{-14} \quad \frac{180}{\pi} \cdot \arg(V_{nN}) = 115.55$$

Calculate the line currents: $I_{aA} := \frac{V_a - V_{nN}}{Z_A + Z_{aA}}$ $I_{bB} := \frac{V_b - V_{nN}}{Z_B + Z_{bB}}$ $I_{cC} := \frac{V_c - V_{nN}}{Z_C + Z_{cC}}$

$$I_{aA} = 1.999 - 1.633i$$

$$I_{bB} = 0.415 + 2.548i$$

$$I_{cC} = -2.414 - 0.915i$$

$$|I_{aA}| = 2.582$$

$$|I_{bB}| = 2.582$$

$$|I_{cC}| = 2.582$$

$$\frac{180}{\pi} \cdot \arg(I_{aA}) = -39.243$$

$$\frac{180}{\pi} \cdot \arg(I_{bB}) = 80.757$$

$$\frac{180}{\pi} \cdot \arg(I_{cC}) = -159.243$$

Calculate the power delivered to the load:

$$S_A := \frac{(\overline{I_{aA}} \cdot I_{aA})}{2} \cdot Z_A$$

$$S_B := \frac{(\overline{I_{bB}} \cdot I_{bB})}{2} \cdot Z_B$$

$$S_C := \frac{(\overline{I_{cC}} \cdot I_{cC})}{2} \cdot Z_C$$

$$S_A = 66.645 + 75.375i$$

$$S_B = 66.645 + 75.375i$$

$$S_C = 66.645 + 75.375i$$

Total power delivered to the load: $S_A + S_B + S_C = 199.934 + 226.125i$

The average power delivered to the load is $P = \text{Re}\{S\} = \text{Re}\{200 + j226\} = 200 \text{ W}$

P12.4-6

Unbalanced, three-wire, Y-Y circuit:

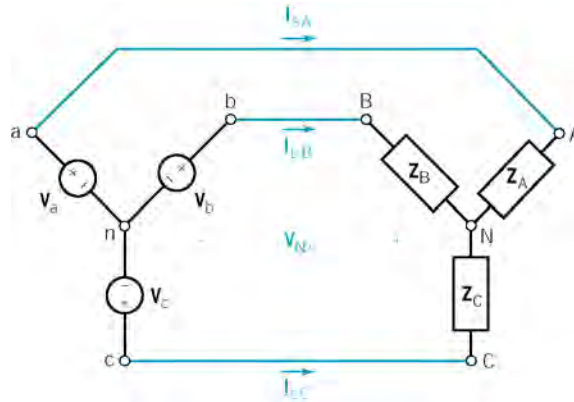

where

$$\mathbf{V}_a = 10 \angle -90^\circ \text{ V} = 7.07 \angle -90^\circ \text{ V rms}, \mathbf{V}_b = 7.07 \angle 150^\circ \text{ V rms} \text{ and } \mathbf{V}_c = 7.07 \angle 30^\circ \text{ V rms}$$

and

$$\mathbf{Z}_A = 4 + j(4)(1) = 4 + j4 \ \Omega, \mathbf{Z}_B = 2 + j(4)(2) = 2 + j8 \ \Omega \text{ and } \mathbf{Z}_C = 4 + j(4)(2) = 4 + j8 \ \Omega$$

Mathcad Analysis (12p4_6.mcd):

Describe the three-phase source: $V_p := 10$

$$V_a := V_p \cdot e^{j \cdot \frac{\pi}{180} \cdot -90} \quad V_b := V_p \cdot e^{j \cdot \frac{\pi}{180} \cdot 150} \quad V_c := V_p \cdot e^{j \cdot \frac{\pi}{180} \cdot 30}$$

Enter the frequency of the 3-phase source: $\omega := 4$

Describe the three-phase load: $Z_A := 4 + j \cdot \omega \cdot 1$ $Z_B := 2 + j \cdot \omega \cdot 2$ $Z_C := 4 + j \cdot \omega \cdot 2$

Calculate the voltage at the neutral of the load with respect to the neutral of the source:

$$V_{nN} := \frac{Z_A \cdot Z_C \cdot V_b + Z_A \cdot Z_B \cdot V_c + Z_B \cdot Z_C \cdot V_a}{Z_A \cdot Z_C + Z_A \cdot Z_B + Z_B \cdot Z_C}$$

$$V_{nN} = 1.528 - 0.863i \quad |V_{nN}| = 1.755 \quad \frac{180}{\pi} \cdot \arg(V_{nN}) = -29.466$$

Calculate the line currents: $I_{aA} := \frac{V_a - V_{nN}}{Z_A}$ $I_{bB} := \frac{V_b - V_{nN}}{Z_B}$ $I_{cC} := \frac{V_c - V_{nN}}{Z_C}$

$$I_{aA} = -1.333 - 0.951i \quad I_{bB} = 0.39 + 1.371i \quad I_{cC} = 0.943 - 0.42i$$

$$|I_{aA}| = 1.638 \quad |I_{bB}| = 1.426 \quad |I_{cC}| = 1.032$$

$$\frac{180}{\pi} \cdot \arg(I_{aA}) = -144.495 \quad \frac{180}{\pi} \cdot \arg(I_{bB}) = 74.116 \quad \frac{180}{\pi} \cdot \arg(I_{cC}) = -24.011$$

Calculate the power delivered to the load:

$$S_A := \frac{(\overline{I_{aA}} \cdot I_{aA})}{2} \cdot Z_A \quad S_B := \frac{(\overline{I_{bB}} \cdot I_{bB})}{2} \cdot Z_B \quad S_C := \frac{(\overline{I_{cC}} \cdot I_{cC})}{2} \cdot Z_C$$

$$S_A = 5.363 + 5.363i \quad S_B = 2.032 + 8.128i \quad S_C = 2.131 + 4.262i$$

Total power delivered to the load: $S_A + S_B + S_C = 9.527 + 17.754i$

The average power delivered to the load is $P = \text{Re}\{S\} = \text{Re}\{9.527 + j17.754\} = 9.527 \text{ W}$

P12.4-7

Unbalanced, three-wire, Y-Y circuit:

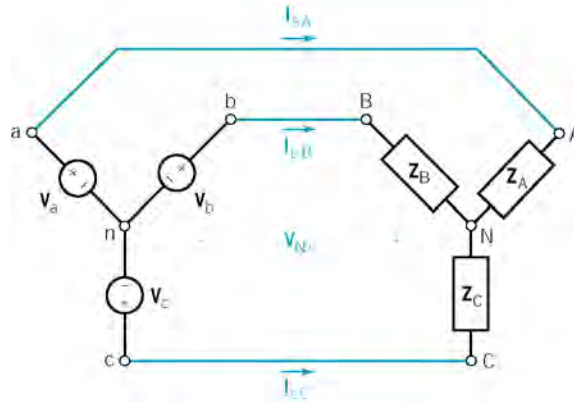

where

$V_a = 10 \angle -90^\circ \text{ V} = 7.07 \angle -90^\circ \text{ V rms}$, $V_b = 7.07 \angle 150^\circ \text{ V rms}$ and $V_c = 7.07 \angle 30^\circ \text{ V rms}$
and

$$Z_A = Z_B = Z_C = 4 + j(4)(2) = 4 + j8 \ \Omega$$

Mathcad Analysis (12p4_7.mcd):

Describe the three-phase source: $V_p := 10$

$$V_a := V_p \cdot e^{j \cdot \frac{\pi}{180} \cdot -90} \quad V_b := V_p \cdot e^{j \cdot \frac{\pi}{180} \cdot 150} \quad V_c := V_p \cdot e^{j \cdot \frac{\pi}{180} \cdot 30}$$

Enter the frequency of the 3-phase source: $\omega := 4$

Describe the three-phase load: $Z_A := 4 + j \cdot \omega \cdot 2 \quad Z_B := Z_A \quad Z_C := Z_A$

The voltage at the neutral of the load with respect to the neutral of the source should be zero:

$$V_{nN} := \frac{Z_A \cdot Z_C \cdot V_b + Z_A \cdot Z_B \cdot V_c + Z_B \cdot Z_C \cdot V_a}{Z_A \cdot Z_C + Z_A \cdot Z_B + Z_B \cdot Z_C} \quad |V_{nN}| = 1.517 \times 10^{-15}$$

Calculate the line currents: $I_{aA} := \frac{V_a - V_{nN}}{Z_A}$ $I_{bB} := \frac{V_b - V_{nN}}{Z_B}$ $I_{cC} := \frac{V_c - V_{nN}}{Z_C}$

$I_{aA} = -1 - 0.5i$

$I_{bB} = 0.067 + 1.116i$

$I_{cC} = 0.933 - 0.616i$

$|I_{aA}| = 1.118$

$|I_{bB}| = 1.118$

$|I_{cC}| = 1.118$

$\frac{180}{\pi} \cdot \arg(I_{aA}) = -153.435$

$\frac{180}{\pi} \cdot \arg(I_{bB}) = 86.565$

$\frac{180}{\pi} \cdot \arg(I_{cC}) = -33.435$

Calculate the power delivered to the load:

$S_A := \frac{(\overline{I_{aA}} \cdot I_{aA})}{2} \cdot Z_A$

$S_B := \frac{(\overline{I_{bB}} \cdot I_{bB})}{2} \cdot Z_B$

$S_C := \frac{(\overline{I_{cC}} \cdot I_{cC})}{2} \cdot Z_C$

$S_A = 2.5 + 5i$

$S_B = 2.5 + 5i$

$S_C = 2.5 + 5i$

Total power delivered to the load: $S_A + S_B + S_C = 7.5 + 15i$

The average power delivered to the load is $P = \text{Re}\{S\} = \text{Re}\{7.5 + j15\} = 7.5 \text{ W}$

Section 12-6: The Δ- Connected Source and Load

P12.5-1

Given $I_B = 50 \angle -40^\circ \text{ A rms}$ and assuming the *abc* phase sequence we have

$I_A = 50 \angle 80^\circ \text{ A rms}$ and $I_C = 50 \angle 200^\circ \text{ A rms}$

From Eqn 12.6-4

$I_A = I_{AB} \times \sqrt{3} \angle -30^\circ \Rightarrow I_{AB} = \frac{I_A}{\sqrt{3} \angle -30^\circ}$

so

$I_{AB} = \frac{50 \angle 80^\circ}{\sqrt{3} \angle -30^\circ} = 28.9 \angle 110^\circ \text{ A rms}$

$I_{BC} = 28.9 \angle -10^\circ \text{ A rms}$ and $I_{CA} = 28.9 \angle -130^\circ \text{ A rms}$

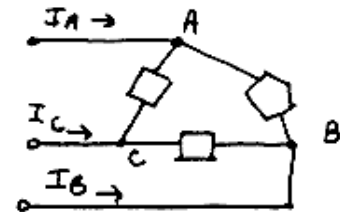

P12.5-2

The two delta loads connected in parallel are equivalent to a single delta load with

$$\mathbf{Z}_{\Delta} = 5 \parallel 20 = 4 \ \Omega$$

The magnitude of phase current is

$$I_p = \frac{480}{4} = 120 \text{ A rms}$$

The magnitude of line current is

$$I_L = \sqrt{3} I_p = 208 \text{ A rms}$$

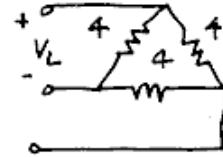

Section 12-6: The Y- to Δ - Circuit

P12.6-1

We have a delta load with $\mathbf{Z} = 12 \angle 30^\circ$. One phase current is

$$\mathbf{I}_{AB} = \frac{\mathbf{V}_{AB}}{\mathbf{Z}} = \frac{\mathbf{V}_A - \mathbf{V}_B}{\mathbf{Z}} = \frac{\left(\frac{208}{\sqrt{3}} \angle -30^\circ\right) - \left(\frac{208}{\sqrt{3}} \angle -150^\circ\right)}{12 \angle 30^\circ} = \frac{208 \angle 0^\circ}{12 \angle 30^\circ} = 17.31 \angle -30^\circ \text{ A rms}$$

The other phase currents are

$$\mathbf{I}_{BC} = 17.31 \angle -150^\circ \text{ A rms and } \mathbf{I}_{CA} = 17.31 \angle 90^\circ \text{ A rms}$$

One line currents is

$$\mathbf{I}_A = \mathbf{I}_{AB} \times \sqrt{3} \angle -30^\circ = (17.31 \angle -30^\circ) \times (\sqrt{3} \angle -30^\circ) = 30 \angle 0^\circ \text{ A rms}$$

The other line currents are

$$\mathbf{I}_B = 30 \angle -120^\circ \text{ A rms and } \mathbf{I}_C = 30 \angle 120^\circ \text{ A rms}$$

The power delivered to the load is

$$P = 3 \left(\frac{208}{\sqrt{3}}\right) (30) \cos(0 - 30^\circ) = 9360 \text{ W}$$

P12.6-2

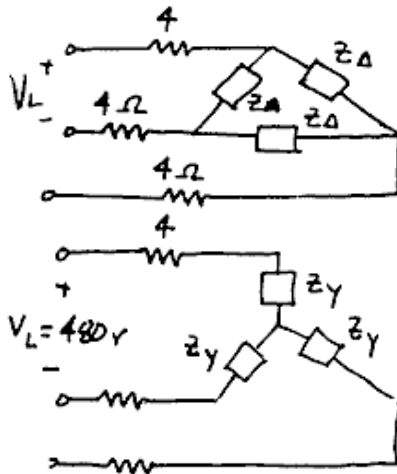

The balanced delta load with $Z_{\Delta} = 39\angle-40^{\circ} \Omega$ is equivalent to a balanced Y load with

$$Z_Y = \frac{Z_{\Delta}}{3} = 13\angle-40^{\circ} = 9.96 - j8.36 \Omega$$

$$Z_T = Z_Y + 4 = 13.96 - j8.36 = 16.3\angle-30.9^{\circ} \Omega$$

$$\text{then } I_A = \frac{\frac{480}{\sqrt{3}}\angle-30^{\circ}}{16.3\angle-30.9^{\circ}} = 17\angle0.9^{\circ} \text{ A rms}$$

P12.6-3

$$V_{ab} = V_a \times \sqrt{3}\angle30^{\circ} \Rightarrow V_a = \frac{V_{ab}}{\sqrt{3}\angle30^{\circ}}$$

In our case, the given line-to-line voltage is

$$V_{ab} = 380\angle30^{\circ} \text{ V rms}$$

$$\text{So one phase voltage is } V_a = \frac{380\angle30^{\circ}}{\sqrt{3}\angle30^{\circ}} = 220\angle0^{\circ} \text{ V rms}$$

So

$$V_{AB} = 380\angle30^{\circ} \text{ V rms} \quad V_A = 220\angle0^{\circ} \text{ V rms}$$

$$V_{BC} = 380\angle-90^{\circ} \text{ V rms} \quad V_B = 220\angle-120^{\circ} \text{ V rms}$$

$$V_{CA} = 380\angle150^{\circ} \text{ V rms} \quad V_C = 220\angle120^{\circ} \text{ V rms}$$

One phase current is

$$I_A = \frac{V_A}{Z} = \frac{220\angle0^{\circ}}{3+j4} = 44\angle-53.1^{\circ} \text{ A rms}$$

The other phase currents are

$$I_B = 44\angle-173.1^{\circ} \text{ A rms} \quad \text{and} \quad I_C = 44\angle66.9^{\circ} \text{ A rms}$$

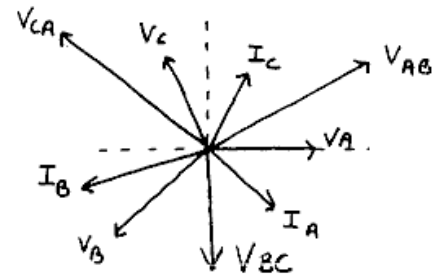

P12.6-4

$$\mathbf{V}_{ab} = \mathbf{V}_a \times \sqrt{3} \angle 30^\circ \Rightarrow \mathbf{V}_a = \frac{\mathbf{V}_{ab}}{\sqrt{3} \angle 30^\circ}$$

In our case, the given line-to-line voltage is

$$\mathbf{V}_{ab} = 380 \angle 0^\circ \text{ V rms}$$

So one phase voltage is
$$\mathbf{V}_a = \frac{380 \angle 0^\circ}{\sqrt{3} \angle 30^\circ} = 220 \angle -30^\circ \text{ V rms}$$

So

$$\mathbf{V}_{ab} = 380 \angle 0^\circ \text{ V rms} \quad \mathbf{V}_a = 220 \angle -30^\circ \text{ V rms}$$

$$\mathbf{V}_{bc} = 380 \angle -120^\circ \text{ V rms} \quad \mathbf{V}_b = 220 \angle -150^\circ \text{ V rms}$$

$$\mathbf{V}_{ca} = 380 \angle 120^\circ \text{ V rms} \quad \mathbf{V}_c = 220 \angle 90^\circ \text{ V rms}$$

One phase current is

$$\mathbf{I}_A = \frac{\mathbf{V}_a}{\mathbf{Z}} = \frac{220 \angle -30^\circ}{9 + j12} = 14.67 \angle -83.1^\circ \text{ A rms}$$

The other phase currents are

$$\mathbf{I}_B = 14.67 \angle -203.1^\circ \text{ A rms} \quad \text{and} \quad \mathbf{I}_C = 14.67 \angle 36.9^\circ \text{ A rms}$$

Section 12-7: Balanced Three-Phase Circuits

P12.7-1

$$\mathbf{V}_a = \frac{25}{\sqrt{3}} \times 10^3 \angle 0^\circ \text{ Vrms}$$

$$\mathbf{I}_A = \frac{\mathbf{V}_a}{\mathbf{Z}} = \frac{\frac{25}{\sqrt{3}} \times 10^3 \angle 0^\circ}{150 \angle 25^\circ} = 96 \angle -25^\circ \text{ A rms}$$

$$P = 3|\mathbf{V}_a||\mathbf{I}_A| \cos(\theta_V - \theta_I) = 3 \left(\frac{25}{\sqrt{3}} \times 10^3 \right) 96 \cos(0 - 25^\circ) = \underline{3.77 \text{ mW}}$$

P12.7-2

Convert the delta load to an equivalent Y connected load:

$$\mathbf{Z}_\Delta = 50 \Omega \quad \mathbf{Z}_\Delta \Rightarrow \hat{\mathbf{Z}}_Y = \frac{50}{3} \Omega$$

To get the per-phase equivalent circuit shown to the right:

The phase voltage of the source is

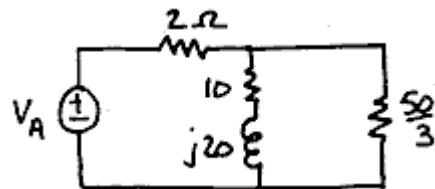

$$\mathbf{V}_a = \frac{45 \times 10^3}{\sqrt{3}} \angle 0^\circ = 26 \angle 0^\circ \text{ kV rms}$$

The equivalent impedance of the load together with the line is

$$\mathbf{Z}_{\text{eq}} = \frac{(10 + j20) \frac{50}{3}}{10 + j20 + \frac{50}{3}} + 2 = 12 + j5 = 13 \angle 22.6^\circ \Omega$$

The line current is

$$\mathbf{I}_{aA} = \frac{\mathbf{V}_a}{\mathbf{Z}_{\text{eq}}} = \frac{26 \times 10^3 \angle 0^\circ}{13 \angle 22.6^\circ} = 2000 \angle -22.6^\circ \text{ A rms}$$

The power delivered to the parallel loads (per phase) is

$$P_{\text{Loads}} = |\mathbf{I}_{aA}|^2 \times \text{Re} \left\{ \frac{(10 + j20) \frac{50}{3}}{10 + j20 + \frac{50}{3}} \right\} = 4 \times 10^6 \times 10 = 40 \text{ MW}$$

The power lost in the line (per phase) is

$$P_{\text{Line}} = |\mathbf{I}_{aA}|^2 \times \text{Re}\{\mathbf{Z}_{\text{Line}}\} = 4 \times 10^6 \times 2 = 8 \text{ MW}$$

The percentage of the total power lost in the line is

$$\frac{P_{\text{Line}}}{P_{\text{Load}} + P_{\text{Line}}} \times 100\% = \frac{8}{40+8} \times 100\% = \underline{16.7\%}$$

P12.7-3

$$\mathbf{I}_a = \frac{\mathbf{V}_a}{\mathbf{Z}_T} = \frac{5 \angle 30^\circ}{6 + j8} = 0.5 \angle -23^\circ \text{ A} \quad \therefore |\mathbf{I}_a| = 0.5 \text{ A}$$

$$P_{\text{Load}} = 3 \left| \frac{\mathbf{I}_a}{\sqrt{2}} \right|^2 \text{Re}\{\mathbf{Z}_{\text{Load}}\} = 3 \times 0.125 \times 4 = 1.5 \text{ W}$$

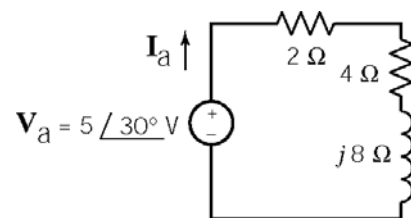

also (but not required) :

$$P_{\text{Source}} = 3 \frac{(5)(0.5)}{2} \cos(-30 - 23) = 2.25 \text{ W}$$

$$P_{\text{line}} = 3 \left| \frac{\mathbf{I}_a}{\sqrt{2}} \right|^2 \text{Re}\{\mathbf{Z}_{\text{Line}}\} = 3 \times 0.125 \times 2 = 0.75 \text{ W}$$

Section 12-8: Power in a Balanced Load

P12.8-1

Assuming the *abc* phase sequence:

$$\mathbf{V}_{CB} = 208\angle 15^\circ \text{ V rms} \Rightarrow \mathbf{V}_{BC} = 208\angle 195^\circ \text{ V rms} \Rightarrow \mathbf{V}_{AB} = 208\angle 315^\circ \text{ V rms}$$

Then

$$\mathbf{V}_A = \frac{\mathbf{V}_{AB}}{\sqrt{3}\angle 30^\circ} = \frac{208\angle 315^\circ}{\sqrt{3}\angle 30^\circ} = \frac{208}{\sqrt{3}}\angle 285^\circ \text{ V rms}$$

also

$$\mathbf{I}_B = 3\angle 110^\circ \text{ A rms} \Rightarrow \mathbf{I}_A = 3\angle 230^\circ \text{ A rms}$$

Finally

$$P = 3|\mathbf{V}_{AB}||\mathbf{I}_A|\cos(\theta_V - \theta_I) = 3\left(\frac{208}{\sqrt{3}}\right)(3)\cos(285^\circ - 230^\circ) = \underline{620 \text{ W}}$$

P12.8-2

Assuming a lagging power factor:

$$\cos \theta = pf = 0.8 \Rightarrow \theta = 36.9^\circ$$

The power supplied by the three-phase source is given by

$$P_{in} = \frac{P_{out}}{\eta} = \frac{20(745.7)}{0.85} = 17.55 \text{ kW where } 1 \text{ hp} = 745.7 \text{ W}$$

$$P_{in} = 3|\mathbf{I}_A||\mathbf{V}_A|pf \Rightarrow |\mathbf{I}_A| = \frac{P_{in}}{3|\mathbf{V}_A|pf} = \frac{17.55 \times 10^3}{3\left(\frac{480}{\sqrt{3}}\right)(0.8)} = 26.4 \text{ A rms}$$

$$\mathbf{I}_A = 26.4\angle -36.9^\circ \text{ A rms when } \mathbf{V}_A = \frac{480}{\sqrt{3}}\angle 0^\circ \text{ V rms}$$

P12.8-3

(a) For a Δ -connected load, Eqn 12.8-5 gives

$$P_T = 3 |\mathbf{V}_p| |\mathbf{I}_L| pf \Rightarrow |\mathbf{I}_L| = \frac{P_T}{3 |\mathbf{V}_p| |\mathbf{I}_L| pf} = \frac{1500}{3 \left(\frac{220}{\sqrt{3}} \right) (0.8)} = 4.92 \text{ A rms}$$

The phase current in the Δ -connected load is given by

$$\mathbf{I}_p = \frac{\mathbf{I}_L}{\sqrt{3}} \Rightarrow |\mathbf{I}_p| = \frac{|\mathbf{I}_L|}{\sqrt{3}} = \frac{4.92}{\sqrt{3}} = 2.84 \text{ A rms}$$

The phase impedance is determined as:

$$\mathbf{Z} = \frac{\mathbf{V}_L}{\mathbf{I}_p} = \frac{|\mathbf{V}_L|}{|\mathbf{I}_p|} \angle (\theta_v - \theta_i) = \frac{|\mathbf{V}_L|}{|\mathbf{I}_p|} \angle \cos^{-1} pf = \frac{220}{2.84} \angle \cos^{-1} 0.8 = 77.44 \angle 36.9^\circ \Omega$$

(b) For a Δ -connected load, Eqn 12.8-4 gives

$$P_T = 3 |\mathbf{V}_p| |\mathbf{I}_L| pf \Rightarrow |\mathbf{I}_L| = \frac{P_T}{3 |\mathbf{V}_p| |\mathbf{I}_L| pf} = \frac{1500}{3 \left(\frac{220}{\sqrt{3}} \right) (0.8)} = 4.92 \text{ A rms}$$

The phase impedance is determined as:

$$\mathbf{Z} = \frac{\mathbf{V}_p}{\mathbf{I}_p} = \frac{|\mathbf{V}_p|}{|\mathbf{I}_p|} \angle (\theta_v - \theta_i) = \frac{|\mathbf{V}_p|}{|\mathbf{I}_p|} \angle \cos^{-1} pf = \frac{220}{4.92} \angle \cos^{-1} 0.8 = 25.8 \angle 36.9^\circ \Omega$$

P12.8-4

Parallel Δ loads

$$\mathbf{Z}_\Delta = \frac{\mathbf{Z}_1 \mathbf{Z}_2}{\mathbf{Z}_1 + \mathbf{Z}_2} = \frac{(40 \angle 30^\circ) (50 \angle -60^\circ)}{40 \angle 30^\circ + 50 \angle -60^\circ} = 31.2 \angle -8.7^\circ \Omega$$

$$\mathbf{V}_L = \mathbf{V}_p, |\mathbf{I}_p| = \frac{|\mathbf{V}_p|}{|\mathbf{Z}_\Delta|} = \frac{600}{31.2} = 19.2 \text{ A rms}, |\mathbf{I}_L| = \sqrt{3} |\mathbf{I}_p| = 33.3 \text{ A rms}$$

$$\text{So } P = \sqrt{3} |\mathbf{V}_L| |\mathbf{I}_L| pf = \sqrt{3} (600) (33.3) \cos (-8.7^\circ) = \underline{34.2 \text{ kW}}$$

P12.8-5

We will use

$$\mathbf{S} = |\mathbf{S}| \angle \theta = |\mathbf{S}| \cos \theta + j |\mathbf{S}| \sin \theta = |\mathbf{S}| pf + j |\mathbf{S}| \sin(\cos^{-1} pf)$$

In our case:

$$\tilde{\mathbf{S}}_1 = 39(0.7) + j39 \sin(\cos^{-1}(0.7)) = 27.3 + j 27.85 \text{ kVA}$$

$$\tilde{\mathbf{S}}_2 = 15 + \frac{15}{0.21} \sin(\cos^{-1}(0.21)) = 15 - j 69.84 \text{ kVA}$$

$$\tilde{\mathbf{S}}_{3\phi} = \tilde{\mathbf{S}}_1 + \tilde{\mathbf{S}}_2 = 42.3 - j 42.0 \text{ kVA} \Rightarrow \tilde{\mathbf{S}}_{\phi} = \frac{\tilde{\mathbf{S}}_{3\phi}}{3} = 14.1 - j 14.0 \text{ kVA}$$

The line current is

$$\mathbf{S} = \mathbf{V}_p \mathbf{I}_L^* \Rightarrow \tilde{\mathbf{I}}_L = \left(\frac{\mathbf{S}}{\mathbf{V}_p} \right)^* = \frac{(14100 + j 14000)}{\frac{208}{\sqrt{3}}} = 117.5 + j 116.7 \text{ A rms} = 167 \angle 45^\circ \text{ A rms}$$

The phase voltage at the load is required to be $\frac{208}{\sqrt{3}} \angle 0^\circ = 120 \angle 0^\circ \text{ V rms}$. The source must provide this voltage plus the voltage dropped across the line, therefore

$$\tilde{\mathbf{V}}_{s\phi} = 120 \angle 0^\circ + (0.038 + j 0.072)(117.5 + j 116.7) = 115.9 + j 12.9 = 116.6 \angle 6.4^\circ \text{ V rms}$$

Finally

$$|\tilde{\mathbf{V}}_{s\phi}| = 116.6 \text{ V rms}$$

P12.8-6

The required phase voltage at the load is $\mathbf{V}_p = \frac{4.16}{\sqrt{3}} \angle 0^\circ = 2.402 \angle 0^\circ \text{ kVrms}$.

Let \mathbf{I}_1 be the line current required by the Δ -connected load. The apparent power per phase required by the Δ -connected load is $|\mathbf{S}_1| = \frac{500 \text{ kVA}}{3} = 167 \text{ kVA}$. Then

$$\mathbf{S}_1 = |\mathbf{S}_1| \angle \theta = |\mathbf{S}_1| \angle \cos^{-1}(pf) = 167 \angle \cos^{-1}(0.85) = 167 \angle 31.8^\circ \text{ kVA}$$

and

$$\mathbf{S}_1 = \mathbf{V}_p \mathbf{I}_1^* \Rightarrow \mathbf{I}_1 = \left(\frac{\mathbf{S}_1}{\mathbf{V}_p} \right)^* = \left(\frac{(167 \times 10^3) \angle 31.8^\circ}{(2.402 \times 10^3) \angle 0^\circ} \right)^* = 69.6 \angle -31.8^\circ = 59 - j 36.56 \text{ A rms}$$

Let \mathbf{I}_2 be the line current required by the first Y-connected load. The apparent power per phase required by this load is $|\mathbf{S}_2| = \frac{75 \text{ kVA}}{3} = 25 \text{ kVA}$. Then, noticing the leading power factor,

$$\mathbf{S}_2 = |\mathbf{S}_2| \angle \theta = |\mathbf{S}_2| \angle \cos^{-1}(pf) = 25 \angle \cos^{-1}(0) = 25 \angle -90^\circ \text{ kVA}$$

and

$$\mathbf{S}_2 = \mathbf{V}_p \mathbf{I}_2^* \Rightarrow \mathbf{I}_2 = \left(\frac{\mathbf{S}_2}{\mathbf{V}_p} \right)^* = \left(\frac{(25 \times 10^3) \angle -90^\circ}{(2.402 \times 10^3) \angle 0^\circ} \right)^* = 10.4 \angle 90^\circ = j10.4 \text{ A rms}$$

Let \mathbf{I}_3 be the line current required by the other Y-connected load. Use Ohm's law to determine \mathbf{I}_3 to be

$$\mathbf{I}_3 = \frac{2402 \angle 0^\circ}{150} + \frac{2402 \angle 0^\circ}{j 225} = 16 - j 10.7 \text{ A rms}$$

The line current is

$$\mathbf{I}_L = \mathbf{I}_1 + \mathbf{I}_2 + \mathbf{I}_3 = 75 - j 36.8 \text{ A rms}$$

The phase voltage at the load is required to be $\mathbf{V}_p = \frac{4.16}{\sqrt{3}} \angle 0^\circ = 2.402 \angle 0^\circ \text{ kVrms}$. The source must provide this voltage plus the voltage dropped across the line, therefore

$$\mathbf{V}_{S\phi} = 2402 \angle 0^\circ + (8.45 + j 3.9) (75 - j 36.8) = 3179 \angle -0.3^\circ \text{ Vrms}$$

Finally

$$|\mathbf{V}_{SL}| = \sqrt{3} (3179) = \underline{5506 \text{ Vrms}}$$

P12.8-7

The required phase voltage at the load is $\mathbf{V}_p = \frac{4.16}{\sqrt{3}} \angle 0^\circ = 2.402 \angle 0^\circ \text{ kVrms}$.

Let \mathbf{I}_1 be the line current required by the Δ -connected load. The apparent power per phase required by the Δ -connected load is $|\mathbf{S}_1| = \frac{1.5 \text{ MVA}}{3} = 0.5 \text{ MVA}$. Then

$$\mathbf{S}_1 = |\mathbf{S}_1| \angle \theta = |\mathbf{S}_1| \angle \cos^{-1}(pf) = 0.5 \angle \cos^{-1}(0.75) = 0.5 \angle 41.4^\circ \text{ MVA}$$

and

$$\mathbf{S}_1 = \mathbf{V}_p \mathbf{I}_1^* \Rightarrow \mathbf{I}_1 = \left(\frac{\mathbf{S}_1}{\mathbf{V}_p} \right)^* = \left(\frac{(0.5 \times 10^6) \angle 41.4^\circ}{(2.402 \times 10^3) \angle 0^\circ} \right)^* = 2081.6 \angle -41.4^\circ = 1561.4 - j1376.6 \text{ A rms}$$

Let \mathbf{I}_2 be the line current required by the first Y-connected load. The complex power, **per phase**, is

$$\mathbf{S}_2 = 0.67 + \frac{0.67}{0.8} \sin(\cos^{-1}(0.8)) = 0.67 + j 0.5 \text{ MVA}$$

$$\begin{aligned} \mathbf{I}_2 &= \left(\frac{\mathbf{S}_2}{\mathbf{V}_p} \right)^* = \left(\frac{(0.67 + j 0.5) \times 10^6}{(2.402 \times 10^3) \angle 0^\circ} \right)^* = \left(\frac{(0.833 \times 10^6) \angle -36.9^\circ}{(2.402 \times 10^3) \angle 0^\circ} \right)^* \\ &= 346.9 \angle -36.9^\circ = 277.4 - j 208.3 \text{ A rms} \end{aligned}$$

The line current is

$$\mathbf{I}_L = \mathbf{I}_1 + \mathbf{I}_2 = 433.7 - j 345.9 = 554.7 \angle -38.6^\circ \text{ A rms}$$

The phase voltage at the load is required to be $\mathbf{V}_p = \frac{4.16}{\sqrt{3}} \angle 0^\circ = 2.402 \angle 0^\circ \text{ kVrms}$. The source must provide this voltage plus the voltage dropped across the line, therefore

$$\mathbf{V}_{s\phi} = 2402 \angle 0^\circ + (0.4 + j 0.8) (433.7 - j 345.9) = 2859.6 \angle -38.6^\circ \text{ Vrms}$$

Finally

$$|\mathbf{V}_{SL}| = \sqrt{3} (2859.6) = \underline{4953 \text{ Vrms}}$$

The power supplied by the source is

$$P_s = \sqrt{3} (4953) (554.7) \cos (4.2^\circ + 38.6^\circ) = \underline{3.49 \text{ MW}}$$

The power lost in the line is

$$P_{\text{Line}} = 3 \times (554.7^2) \times \text{Re}\{0.4 + j 0.8\} = \underline{0.369 \text{ MW}}$$

The percentage of the power consumed by the loads is

$$\frac{3.49 - 0.369}{3.49} \times 100\% = 89.4\%$$

P12.8-8

The required phase voltage at the load is $V_p = \frac{600}{\sqrt{3}} \angle 0^\circ = 346.4 \angle 0^\circ$ Vrms .

$$\begin{aligned}\theta &= \cos^{-1}(0.8) \\ &= 37^\circ\end{aligned}$$

Let \mathbf{I} be the line current required by the load. The complex power, **per phase**, is

$$\mathbf{S} = 160 + \frac{160}{0.8} \sin(\cos^{-1}(0.8)) = 160 + j 120 \text{ kVA}$$

The line current is

$$\mathbf{I} = \left(\frac{\mathbf{S}}{V_p} \right)^* = \left(\frac{(160 + j120) \times 10^3}{346.4 \angle 0^\circ} \right)^* = 461.9 - j346.4 \text{ A rms}$$

The phase voltage at the load is required to be $V_p = \frac{600}{\sqrt{3}} \angle 0^\circ = 346.4 \angle 0^\circ$ Vrms . The source must provide this voltage plus the voltage dropped across the line, therefore

$$\mathbf{V}_{s\phi} = 346.4 \angle 0^\circ + (0.005 + j 0.025) (461.9 - j 346.4) = 357.5 \angle 1.6^\circ \text{ Vrms}$$

Finally

$$|\mathbf{V}_{SL}| = \sqrt{3} (357.5) = \underline{619.2 \text{ Vrms}}$$

The power factor of the source is

$$pf = \cos(\theta_v - \theta_i) = \cos(1.6 - (-37)) = \underline{0.78}$$

Section 12-9: Two-Wattmeter Power Measurement

P12.9-1

$$P_{\text{out}} = 20 \text{ hp} \times 746 \frac{\text{W}}{\text{hp}} = 14920 \text{ W}$$

$$P_{\text{in}} = \frac{P_{\text{out}}}{\eta} = \frac{14920}{0.746} = 20 \text{ kW}$$

$$P_{\text{in}} = \sqrt{3} |\mathbf{V}_L| |\mathbf{I}_L| \cos \theta \Rightarrow \cos \theta = \frac{P_{\text{in}}}{\sqrt{3} |\mathbf{V}_L| |\mathbf{I}_L|} = \frac{20 \times 10^3}{\sqrt{3} (440) (52.5)} = 0.50$$

$$\Rightarrow \theta \cos^{-1}(0.5) = 60^\circ$$

The powers read by the two wattmeters are

$$P_1 = |\mathbf{V}_L| |\mathbf{I}_L| \cos (\theta + 30^\circ) = (440) (52.5) \cos (60^\circ + 30^\circ) = 0$$

and

$$P_2 = |\mathbf{V}_L| |\mathbf{I}_L| \cos (\theta - 30^\circ) = (440) (52.5) \cos (60^\circ - 30^\circ) = 20 \text{ kW}$$

P12.9-2

$$|\mathbf{V}_p| = |\mathbf{V}_L| = 4000 \text{ V rms} \quad \mathbf{Z}_\Delta = 40 + j 30 = 50 \angle 36.9^\circ$$

$$|\mathbf{I}_p| = \frac{|\mathbf{V}_p|}{|\mathbf{Z}_\Delta|} = \frac{4000}{50} = 80 \text{ A rms} \quad |\mathbf{I}_L| = \sqrt{3} |\mathbf{I}_p| = 138.6 \text{ A rms}$$

$$pf = \cos \theta = \cos (36.9^\circ) = 0.80$$

$$P_1 = V_L I_L \cos (\theta + 30^\circ) = 4000 (138.6) \cos 66.9^\circ = 217.5 \text{ kW}$$

$$P_2 = V_L I_L \cos (\theta - 30^\circ) = 4000 (138.6) \cos 6.9^\circ = 550.4 \text{ kW}$$

$$P_T = P_1 + P_2 = 767.9 \text{ kW}$$

$$\begin{aligned} \text{Check : } P_T &= \sqrt{3} |\mathbf{I}_L| |\mathbf{V}_L| \cos \theta = \sqrt{3} (4000) (138.6) \cos 36.9^\circ \\ &= 768 \text{ kW} \quad \text{which checks} \end{aligned}$$

P12.9-3

$$V_p = |\mathbf{V}_p| = \frac{200}{\sqrt{3}} = 115.47 \text{ V rms}$$

$$\mathbf{V}_A = 115.47 \angle 0^\circ \text{ V rms}, \quad \mathbf{V}_B = 115.47 \angle -120^\circ \text{ V rms}$$

$$\text{and } \mathbf{V}_C = 115.47 \angle 120^\circ \text{ V rms}$$

$$\mathbf{I}_A = \frac{\mathbf{V}_A}{\mathbf{Z}} = \frac{115.47 \angle 0^\circ}{70.7 \angle 45^\circ} = 1.633 \angle -45^\circ \text{ A rms}$$

$$\mathbf{I}_B = 1.633 \angle -165^\circ \text{ A rms} \quad \text{and} \quad \mathbf{I}_C = 1.633 \angle 75^\circ \text{ A rms}$$

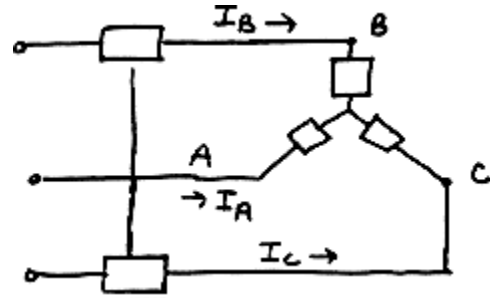

$$P_T = \sqrt{3} |\mathbf{V}_L| |\mathbf{I}_L| \cos \theta = \sqrt{3} (200) (1.633) \cos 45^\circ = 400 \text{ W}$$

$$P_B = |\mathbf{V}_{AC}| |\mathbf{I}_A| \cos \theta_1 = 200 (1.633) \cos (45^\circ - 30^\circ) = 315.47 \text{ W}$$

$$P_C = |\mathbf{V}_{BC}| |\mathbf{I}_B| \cos \theta_2 = 200 (1.633) \cos (45^\circ + 30^\circ) = 84.53 \text{ W}$$

P12.9-4

$$\mathbf{Z}_Y = 10 \angle -30^\circ \Omega \quad \text{and} \quad \mathbf{Z}_\Delta = 15 \angle 30^\circ \Omega$$

$$\text{Convert } \mathbf{Z}_\Delta \text{ to } \mathbf{Z}_{\hat{Y}} \rightarrow \mathbf{Z}_{\hat{Y}} = \frac{\mathbf{Z}_\Delta}{3} = 5 \angle 30^\circ \Omega$$

$$\text{then } \mathbf{Z}_{\text{eq}} = \frac{(10 \angle -30^\circ)(5 \angle 30^\circ)}{10 \angle -30^\circ + 5 \angle 30^\circ} = \frac{50 \angle 0^\circ}{13.228 \angle -10.9^\circ} = 3.78 \angle 10.9^\circ \Omega$$

$$V_p = |\mathbf{V}_p| = \frac{208}{\sqrt{3}} = 120 \text{ V rms}$$

$$\mathbf{V}_A = 120 \angle 0^\circ \text{ V rms} \Rightarrow \mathbf{I}_A = \frac{120 \angle 0^\circ}{3.78 \angle 10.9^\circ} = 31.75 \angle -10.9^\circ$$

$$\mathbf{I}_B = 31.75 \angle -130.9^\circ$$

$$\mathbf{I}_C = 31.75 \angle 109.1^\circ$$

$$P_T = \sqrt{3} V_L I_L \cos \theta = \sqrt{3} (208) (31.75) \cos (10.9) = 11.23 \text{ kW}$$

$$W_1 = V_L I_L \cos(\theta - 30^\circ) = 6.24 \text{ kW}$$

$$W_2 = V_L I_L \cos(\theta + 30^\circ) = 4.99 \text{ kW}$$

P12.9-5

$$P_T = P_A + P_C = 920 + 460 = 1380 \text{ W}$$

$$\tan \theta = \sqrt{3} \frac{P_A - P_C}{P_A + P_C} = \sqrt{3} \frac{(-460)}{1380} = -0.577 \Rightarrow \theta = -30^\circ$$

$$P_T = \sqrt{3} V_L I_L \cos \theta \text{ so } I_L = \frac{P_T}{\sqrt{3} V_L \cos \theta} = \frac{1380}{\sqrt{2} \times 120 \times \cos(-30)} = 7.67 \text{ A rms}$$

$$I_P = \frac{I_L}{\sqrt{3}} = 4.43 \text{ A rms} \quad \therefore |Z_\Delta| = \frac{120}{4.43} = 27.1 \Omega \text{ or } \underline{Z_\Delta = 27.1 \angle -30^\circ}$$

P12.9-6

$$Z = 0.868 + j4.924 = 5 \angle 80^\circ \Rightarrow \theta = 80^\circ$$

$$V_L = 380 \text{ V rms}, V_P = \frac{380}{\sqrt{3}} = 219.4 \text{ V rms}$$

$$I_L = I_P \text{ and } I_P = \frac{V_P}{|Z|} = 43.9 \text{ A rms}$$

$$P_1 = (380)(43.9) \cos(\theta - 30^\circ) = 10,723 \text{ W}$$

$$P_2 = (380)(43.9) \cos(\theta + 30^\circ) = -5706 \text{ W}$$

$$P_T = P_1 + P_2 = 5017 \text{ W}$$

PSpice Problems

SP 12-1

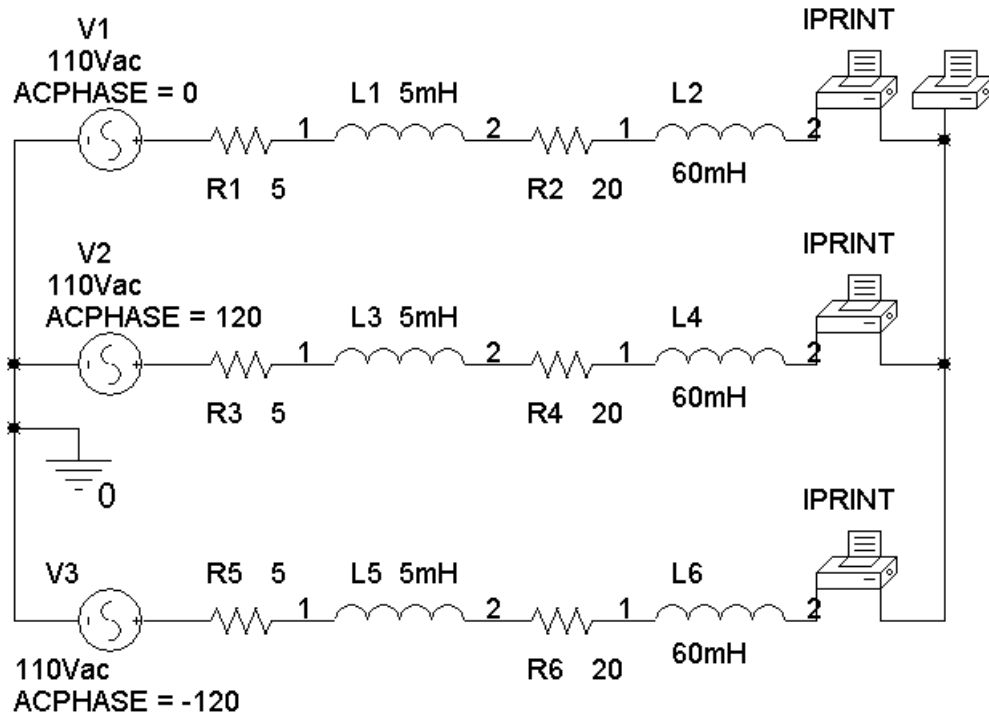

```
FREQ      IM(V_PRINT3) IP(V_PRINT3) IR(V_PRINT3) II(V_PRINT3)
6.000E+01  3.142E+00  -1.644E+02  -3.027E+00  -8.436E-01
```

```
FREQ      IM(V_PRINT1) IP(V_PRINT1) IR(V_PRINT1) II(V_PRINT1)
6.000E+01  3.142E+00  -4.443E+01  2.244E+00  -2.200E+00
```

```
FREQ      VM(N01496)  VP(N01496)  VR(N01496)  VI(N01496)
6.000E+01  2.045E-14  2.211E+01  1.895E-14  7.698E-15
```

```
FREQ      IM(V_PRINT2) IP(V_PRINT2) IR(V_PRINT2) II(V_PRINT2)
6.000E+01  3.142E+00  7.557E+01  7.829E-01  3.043E+00
```

$$\mathbf{I}_A = 3.142 \angle -43.43^\circ \text{ A} \quad \text{and} \quad R_A = 20 \, \Omega \Rightarrow P_A = \frac{3.142^2}{2} 20 = 98.7 \text{ W}$$

$$\mathbf{I}_B = 3.142 \angle 75.57^\circ \text{ A} \quad \text{and} \quad R_B = 20 \, \Omega \Rightarrow P_B = \frac{3.142^2}{2} 20 = 98.7 \text{ W}$$

$$\mathbf{I}_C = 3.142 \angle -164.4^\circ \text{ A} \quad \text{and} \quad R_C = 20 \, \Omega \Rightarrow P_C = \frac{3.142^2}{2} 20 = 98.7 \text{ W}$$

$$P = 3(98.7) = 696.1 \text{ W}$$

SP 12-2

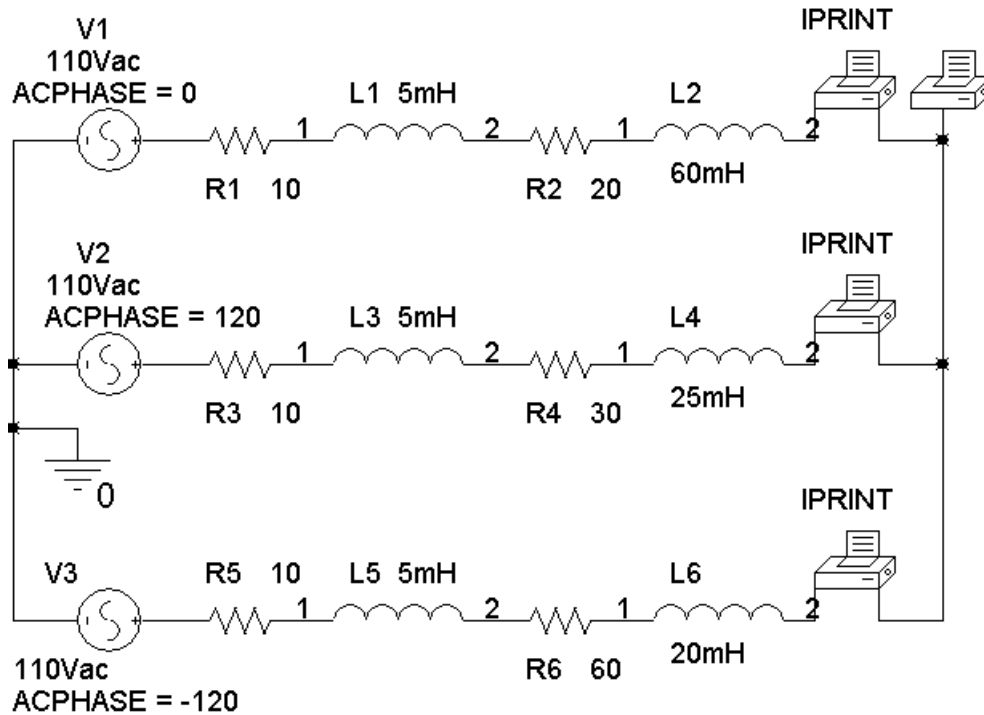

```
FREQ      IM(V_PRINT3) IP(V_PRINT3) IR(V_PRINT3) II(V_PRINT3)
6.000E+01  1.612E+00  -1.336E+02  -1.111E+00  -1.168E+00
```

```
FREQ      IM(V_PRINT1) IP(V_PRINT1) IR(V_PRINT1) II(V_PRINT1)
6.000E+01  2.537E+00  -3.748E+01  2.013E+00  -1.544E+00
```

```
FREQ      VM(N01496)  VP(N01496)  VR(N01496)  VI(N01496)
6.000E+01  1.215E+01  -1.439E+01  1.177E+01  -3.018E+00
```

```
FREQ      IM(V_PRINT2) IP(V_PRINT2) IR(V_PRINT2) II(V_PRINT2)
6.000E+01  2.858E+00  1.084E+02  -9.023E-01  2.712E+00
```

$$\mathbf{I}_A = 2.537 \angle -37.48^\circ \text{ A and } R_A = 20 \ \Omega \Rightarrow P_A = \frac{2.537^2}{2} 20 = 64.4 \text{ W}$$

$$\mathbf{I}_B = 2.858 \angle 108.4^\circ \text{ A and } R_B = 30 \ \Omega \Rightarrow P_B = \frac{2.858^2}{2} 30 = 122.5 \text{ W}$$

$$\mathbf{I}_C = 1.612 \angle -133.6^\circ \text{ A and } R_C = 600 \ \Omega \Rightarrow P_C = \frac{1.612^2}{2} 60 = 78 \text{ W}$$

$$P = 64.4 + 122.5 + 78 = 264.7 \text{ W}$$

Verification Problems

VP 12-1

$$|V_A| = \frac{416}{\sqrt{3}} = 240 \text{ V} = |V_A|$$

$$Z = 10 + j4 = 10.77 \angle 21.8^\circ \Omega$$

$$|I_A| = \frac{|V_A|}{|Z|} = \frac{240}{10.77} = 22.28 \text{ A rms} \neq 38.63 \text{ A rms}$$

The report is not correct. (Notice that $\frac{38.63}{\sqrt{3}} = 22.3$. It appears that the line-to-line voltage was mistakenly used in place of the phase voltage.)

VP 12-2

$$V_L = V_p = 240 \angle 0^\circ \text{ Vrms}$$

$$Z = 40 + j30 = 50 \angle 36.9^\circ \Omega$$

$$I_p = \frac{V_p}{Z} = \frac{240 \angle 0^\circ}{50 \angle 36.9^\circ} = \underline{4.8 \angle -36.9^\circ \text{ A rms}}$$

The result is correct.

Design Problems

DP 12-1

$P = 400 \text{ W}$ per phase,

$$0.94 = pf = \cos \theta \Rightarrow \theta = \cos^{-1}(0.94) = 20^\circ$$

$$400 = \frac{208}{\sqrt{3}} |I_L| 0.94 \Rightarrow |I_L| = 3.5 \text{ A rms}$$

$$|I_A| = \frac{|I_L|}{\sqrt{3}} = 2.04 \text{ A rms}$$

$$|Z| = \frac{|V_L|}{|I_A|} = \frac{208}{2.04} = 101.8 \Omega$$

$$\underline{Z = 101.8 \angle 20^\circ \Omega}$$

DP 12-2

$$|\mathbf{V}_L| = 240 \text{ V rms}$$

$$P_A = |\mathbf{V}_L||\mathbf{I}_L| \cos(30^\circ + \theta) = 1440 \text{ W}$$

$$P_C = |\mathbf{V}_L||\mathbf{I}_L| \cos(30^\circ - \theta) = 0 \text{ W} \Rightarrow 30 - \theta = 90^\circ \text{ or } \theta = -60^\circ$$

$$\text{then } 1440 = 240 |\mathbf{I}_L| \cos(-30^\circ) \Rightarrow |\mathbf{I}_L| = 6.93 \text{ A rms}$$

$$|\mathbf{I}_L| = |\mathbf{I}_P| = \frac{|\mathbf{V}_P|}{|\mathbf{Z}|} \Rightarrow |\mathbf{Z}| = \frac{|\mathbf{V}_P|}{|\mathbf{I}_P|} = \frac{240}{6.93} = 20 \Omega$$

$$\text{Finally, } \mathbf{Z} = 20 \angle -60^\circ \Omega$$

DP 12-3

$$P_{\text{in}} = \frac{P_{\text{out}}}{\eta} = \frac{100 \text{ hp} \times (746 \frac{\text{W}}{\text{hp}})}{0.8} = 93.2 \text{ kW}, P_{\phi} = \frac{P_{\text{in}}}{3} = 31.07 \text{ kW}$$

$V_L = 480 \text{ V rms}$, $pfc = 0.9$ and $pf = 0.75$. We need the impedance of the load so that we can use Eqn 11.6-7 to calculate the value of capacitance needed to correct the power factor.

$$0.75 = pf = \cos \theta \Rightarrow \theta = \cos^{-1}(0.75) = 41.4^\circ$$

$$31070 = \frac{480}{\sqrt{3}} |\mathbf{I}_P| 0.75 \Rightarrow |\mathbf{I}_P| = 149.5 \text{ A rms}$$

$$|\mathbf{Z}| = \frac{|\mathbf{V}_P|}{|\mathbf{I}_P|} = \frac{480}{149.5} = 1.85 \Omega$$

$$\mathbf{Z} = 1.85 \angle 41.4^\circ \Omega = 1.388 + j1.223 \Omega$$

The capacitance required to correct the power factor is given by

$$C = \frac{1.365}{1.365^2 + 1.204^2} \times \frac{[\tan(\cos^{-1}0.75) - \tan(\cos^{-1}0.9)]}{377} = \underline{434 \mu\text{F}}$$

(Checked using LNAPAC 6/12/03)

DP 12-4

$$\mathbf{V}_L = 4\angle 0^\circ \text{ kV rms}$$

$$\text{Try } n_2 = 25 \text{ then } \mathbf{V}_2 = \frac{n_2}{n_1} \mathbf{V}_L = \frac{25}{1} 4000\angle 0^\circ = 100\angle 0^\circ \text{ kVrms}$$

$$\mathbf{I}_L = \frac{\mathbf{V}_L}{\mathbf{Z}_L} = \frac{4 \times 10^3 \angle 0^\circ}{\frac{4}{3}} = 3\angle 0^\circ \text{ kA rms}$$

$$\text{The line current in } 2.5 \Omega \text{ is } \mathbf{I} = \frac{3000\angle 0^\circ}{25} = 120\angle 0^\circ \text{ A rms}$$

$$\text{Thus } \mathbf{V}_1 = (R + jX) \mathbf{I} + \mathbf{V}_2$$

$$= (2.5 + j40) (120\angle 0^\circ) + 100 \times 10^3 = 100.4 \angle 2.7^\circ \text{ kV}$$

$$\text{Step need : } n_1 = \frac{100.4 \text{ kV}}{20 \text{ kV}} = 5.02 \cong 5$$

$$P_{\text{loss}} = |\mathbf{I}|^2 R = |120|^2 (2.5) = 36 \text{ kW}, P = (4 \times 10^3) (3 \times 10^3) = 12 \text{ MW}$$

$$\therefore \eta = \frac{12 - .036}{12} \times 100\% = 99.7\% \text{ of the power supplied by the source}$$

is delivered to the load.

Chapter 13: Frequency Response

Exercises

Ex. 13.3-1

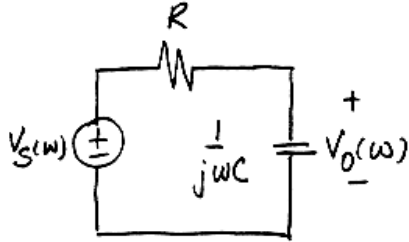

$$\mathbf{H}(\omega) = \frac{\mathbf{V}_o(\omega)}{\mathbf{V}_s(\omega)} = \frac{1}{1 + j\omega CR}$$

$$\text{gain} = \frac{1}{\sqrt{1 + (\omega CR)^2}}$$

$$\text{phase shift} = -\tan^{-1} \omega CR$$

When $R = 10^4$, $\omega = 100$, and $C = 10^{-6}$, then $\text{gain} = \frac{1}{\sqrt{2}} = 0.707$ and $\text{phase shift} = -45^\circ$

Ex. 13.3-2

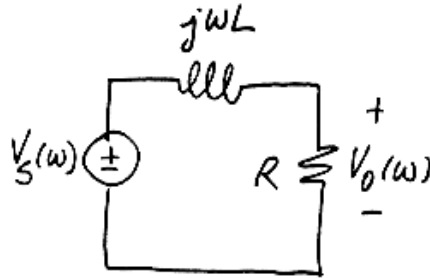

$$\mathbf{H}(\omega) = \frac{\mathbf{V}_o(\omega)}{\mathbf{V}_s(\omega)} = \frac{R}{R + j\omega L}$$

$$\text{gain} = \frac{R}{\sqrt{R^2 + (\omega L)^2}}$$

$$0.6 = \frac{30}{\sqrt{30^2 + (2\omega)^2}} \Rightarrow \omega = \frac{\sqrt{\left(\frac{30}{.6}\right)^2 - 30^2}}{2} = 20 \text{ rad/s}$$

Ex. 13.3-3

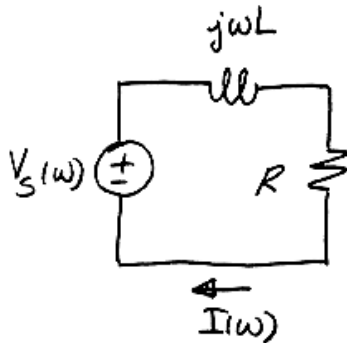

$$\mathbf{H}(\omega) = \frac{\mathbf{I}(\omega)}{\mathbf{V}_s(\omega)} = \frac{1}{R + j\omega L}$$

$$\text{gain} = \frac{1}{\sqrt{R^2 + (\omega L)^2}}$$

$$\text{phase shift} = -\tan^{-1} \frac{\omega L}{R}$$

When $R = 30 \Omega$, $L = 2 \text{ H}$, and $\omega = 20 \text{ rad/s}$, then

$$\text{gain} = \frac{1}{\sqrt{30^2 + 40^2}} = 0.02 \frac{\text{A}}{\text{V}} \quad \text{and} \quad \text{phase shift} = -\tan^{-1} \left(\frac{40}{30} \right) = -53.1^\circ$$

Ex. 13.3-4

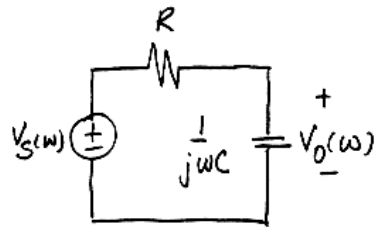

$$\mathbf{H}(\omega) = \frac{\mathbf{V}_o(\omega)}{\mathbf{V}_s(\omega)} = \frac{1}{1 + j\omega CR}$$

$$\text{gain} = \frac{1}{\sqrt{1 + (\omega CR)^2}}$$

$$\text{phase shift} = -\tan^{-1} \omega CR$$

$$-45^\circ = -\tan^{-1}(20 \cdot 10^{-6} \cdot R) \Rightarrow R = \frac{\tan(45^\circ)}{20 \cdot 10^{-6}} = 50 \cdot 10^3 \Omega$$

Ex. 13.3-5

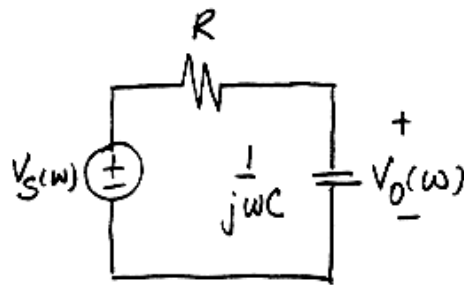

$$\mathbf{H}(\omega) = \frac{\mathbf{V}_o(\omega)}{\mathbf{V}_s(\omega)} = \frac{1}{1 + j\omega CR}$$

$$\text{gain} = \frac{1}{\sqrt{1 + (\omega CR)^2}}$$

ω , C , and R are all positive, or at least nonnegative, so $\text{gain} \leq 1$. These specifications cannot be met.

Ex. 13.4-1

(a) $\text{dB} = 20 \log(.5) = \underline{-6.02 \text{ dB}}$

(b) $\text{dB} = 20 \log 2 = \underline{6.02 \text{ dB}}$

Ex. 13.4-2

$$20 \log \mathbf{H} = 20 \log \left(\frac{1}{\omega^2} \right) = 20 \log (\omega)^{-2} = -40 \log \omega$$

$$\text{slope} = 20 \log \mathbf{H}(\omega_2) - 20 \log \mathbf{H}(\omega_1) = 40 \log \omega_2 + 40 \log \omega_1 = -40 \log \left(\frac{\omega_2}{\omega_1} \right)$$

let $\omega_2 = 10 \omega_1$ to consider 1 decade, then $\text{slope} = \underline{-40 \log 10 = -40 \text{ dB/decade}}$

Ex. 13.4-3

When $\omega C \gg B$, $\mathbf{H}(\omega) \approx \frac{j\omega A}{j\omega C} = \frac{A}{C}$

(d) $|\mathbf{H}(\omega)|$ in dB = $20 \log_{10} |\mathbf{H}(\omega)| = 20 \log_{10} \left(\frac{A}{C} \right)$

(b) $|\mathbf{H}(\omega)|$ does not depend on ω so *slope* = 0

When $\omega C \ll B$, $\mathbf{H}(\omega) \approx \frac{j\omega A}{B} = j\omega \left(\frac{A}{B} \right)$

$|\mathbf{H}(\omega)|$ in dB = $20 \log_{10} |\mathbf{H}(\omega)| = 20 \log_{10} \omega + 20 \log_{10} \left(\frac{A}{B} \right)$

(c) The slope is the coefficient of $20 \log_{10} \omega$, that is, *slope* = 20 dB/decade

(a) The break frequency is the frequency at which $\omega C = B$, that is, $\omega = \frac{B}{C}$

Ex. 13.4-4

$$\begin{aligned} V_o(\omega) &= \left(1 + \frac{R_1}{R_2} \right) V_c(\omega) \\ &= \left(1 + \frac{R_1}{R_2} \right) \left(\frac{1}{1 + j\omega CR} \right) V_s(\omega) \end{aligned}$$

$$\mathbf{H}(\omega) = \frac{V_o(\omega)}{V_s(\omega)} = \left(1 + \frac{R_1}{R_2} \right) \left(\frac{1}{1 + j\omega CR} \right)$$

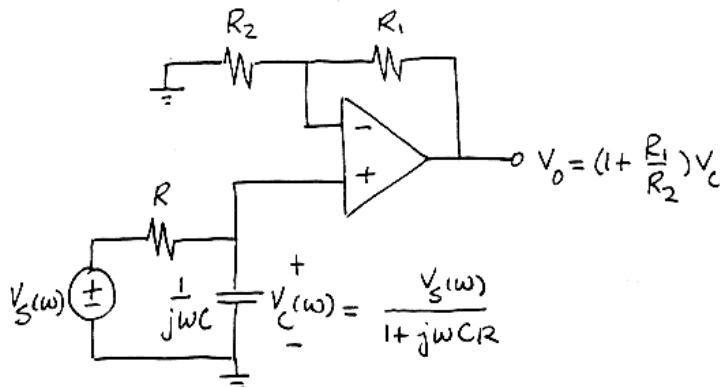

When $RC = 0.1$ and $\frac{R_1}{R_2} = 3$,

then $\mathbf{H}(\omega) = \frac{4}{1 + j\frac{\omega}{10}}$

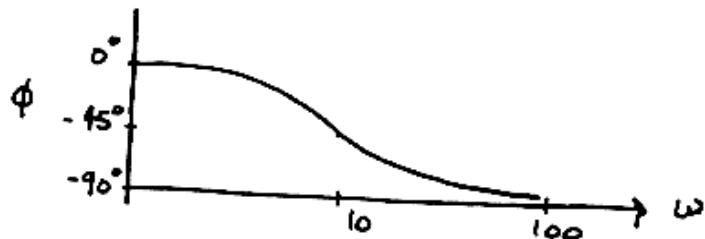
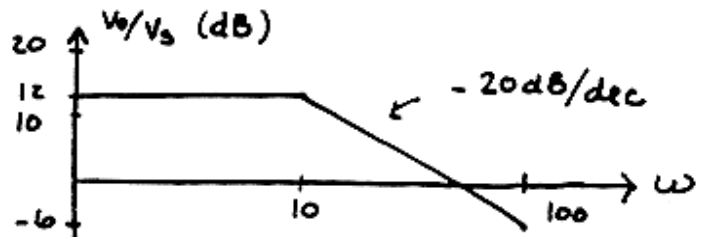

Ex. 13.4-5

a)

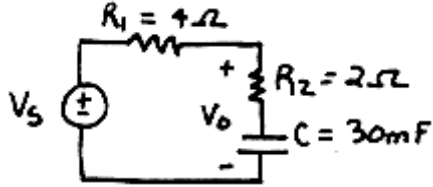

$$Z_o = R_2 + \frac{1}{j\omega C}$$

$$\frac{V_o}{V_s} = \frac{Z_o}{R_1 + Z_o} = \frac{R_2 + \frac{1}{j\omega C}}{R_1 + R_2 + \frac{1}{j\omega C}} = \frac{1 + j\frac{\omega}{\omega_1}}{1 + j\frac{\omega}{\omega_2}}$$

where $\omega_1 = \frac{1}{R_2 C} = 16.7 \text{ rad/s}$

and $\omega_2 = \frac{1}{(R_1 + R_2)C} = 5.56 \text{ rad/s}$

$v_s(t) = 10 \cos 20t$ or $V_s = 10 \angle 0^\circ$

$$\therefore \frac{V_o}{V_s} = \frac{1 + j\left(\frac{20}{16.7}\right)}{1 + j\left(\frac{20}{5.56}\right)}$$

$$= \frac{1 + j 1.20}{1 + j 3.60} = 0.417 \angle -24.3^\circ$$

b) So

$$V_o = 4.17 \angle -24.3^\circ$$

$$\underline{v_o(t) = 4.17 \cos(20t - 24.3^\circ) \text{ V}}$$

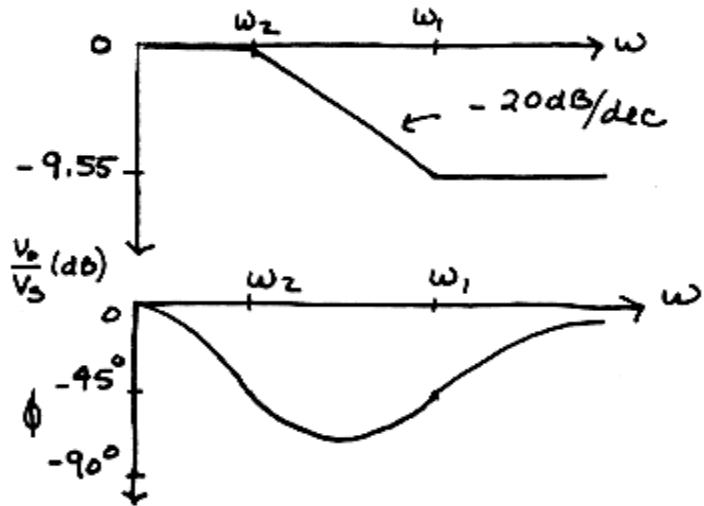

Ex. 13.4-6

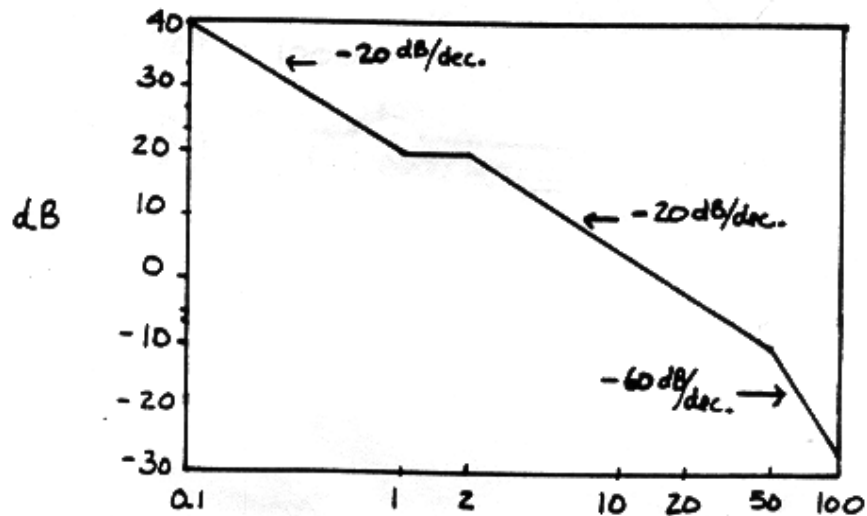

Ex. 13.5-1

$$a) Q \omega_o RC = R \sqrt{C/L} = 8000 \sqrt{\frac{2.5 \times 10^{-7}}{40 \times 10^{-3}}} = \underline{20}$$

$$b) BW = \frac{\omega_o}{Q} = \frac{1}{Q \sqrt{LC}} = \frac{1}{20 \sqrt{(40 \times 10^{-3})(2.5 \times 10^{-7})}} = \underline{500 \text{ rad/s}}$$

Ex. 13.5-2

$$Q = \omega_o / BW = 10^7 / 2 \times 10^5 = \underline{50}$$

$$\text{Now } \omega_o = \frac{1}{\sqrt{LC}} \Rightarrow L = \frac{1}{\omega_o^2 C} = \frac{1}{(10^7)^2 (10 \times 10^{-12})} = \underline{1 \text{ mH}}$$

Ex. 13.5-3

$$\omega_o = \frac{1}{\sqrt{LC}} = \frac{1}{[(10^{-3})(10^{-5})]^{1/2}} = 10^4 \text{ rad/s}$$

$$Q = \omega_o / BW = 10^4 / 2\pi (15.9) = \underline{100}$$

$$R = \frac{\omega_o L}{Q} = \frac{(10^4)(10^{-3})}{100} = \underline{0.1 \Omega}$$

Ex. 13.5-4

$$\text{a) } \omega_0 = \frac{1}{\sqrt{LC}} \Rightarrow C = \frac{1}{(10^6)^2 (0.01)} = \underline{100 \text{ pF}}$$

$$Q = \frac{\omega_0}{BW} = \frac{1}{\omega_0 RC} \Rightarrow R = \frac{BW}{\omega_0^2 C} = \frac{10^3}{(10^6)^2 (10^{-10})} = \underline{10 \ \Omega}$$

$$\text{b) } Q = \frac{\omega_0}{BW} = \frac{10^6}{10^3} = 1000$$

$$\mathbf{H} = \frac{1}{1+jQ\left(\frac{\omega}{\omega_0} - \frac{\omega_0}{\omega}\right)} = \frac{1}{1+j1000\left[\frac{1.05 \times 10^6}{10^6} - \frac{10^6}{1.05 \times 10^4}\right]}$$

$$\underline{\underline{\mathbf{H} = \frac{1}{1+j 97.6}}}$$

Problems

Section 13-3: Gain, Phase Shift, and the Network Function

P13.3-1

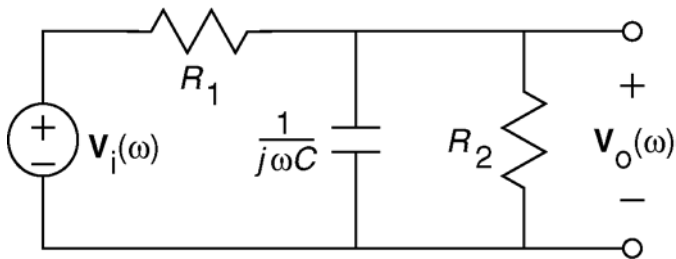

$$R_2 \parallel \frac{1}{j\omega C} = \frac{R_2}{1 + j\omega C R_2}$$

$$\mathbf{H}(\omega) = \frac{\mathbf{V}_o(\omega)}{\mathbf{V}_i(\omega)} = \frac{\frac{R_2}{1 + j\omega C R_2}}{R_1 + \frac{R_2}{1 + j\omega C R_2}}$$

$$= \frac{\frac{R_2}{1 + j\omega C R_2}}{\frac{R_1 + R_2 + \frac{R_2}{1 + j\omega C R_2}}{1 + j\omega C R_2}}$$

$$= \frac{R_2}{R_1 + R_2 + \frac{R_2}{1 + j\omega C R_2}}$$

$$= \frac{R_2}{1 + j\omega C R_p}$$

where $R_p = R_1 \parallel R_2$.

When $R_1 = 40 \Omega$, $R_2 = 10 \Omega$ and $C = 0.5 \text{ F}$

$$\mathbf{H}(\omega) = \frac{0.2}{1 + j4\omega}$$

(checked using ELab on 8/6/02)

P13.3-2

$$\mathbf{H}(\omega) = \frac{\mathbf{V}_o(\omega)}{\mathbf{V}_i(\omega)} = \frac{R_2 + \frac{1}{j\omega C}}{R_1 + R_2 + \frac{1}{j\omega C}}$$

$$= \frac{1 + j\omega C R_2}{1 + j\omega C (R_1 + R_2)}$$

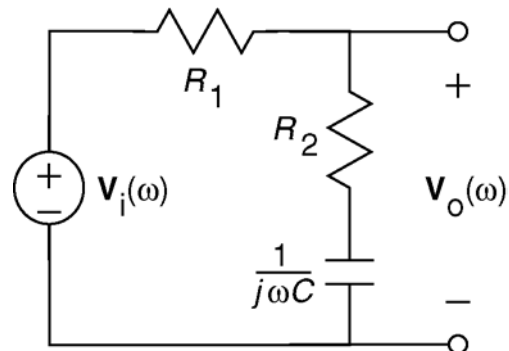

When $R_1 = 40 \text{ k}\Omega$, $R_2 = 160 \text{ k}\Omega$ and $C = 0.025 \mu\text{F}$

$$\mathbf{H}(\omega) = \frac{1 + j(0.004)\omega}{1 + j(0.005)\omega}$$

(checked using ELab on 8/6/02)

P13.3-3

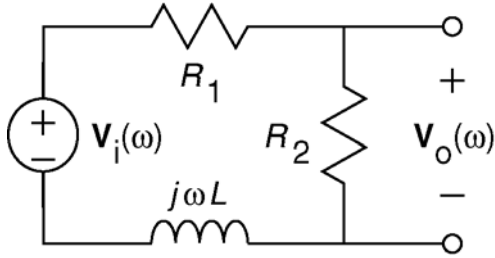

$$\begin{aligned} \mathbf{H}(\omega) &= \frac{\mathbf{V}_o(\omega)}{\mathbf{V}_i(\omega)} = \frac{R_2}{R_1 + R_2 + j\omega L} \\ &= \frac{\frac{R_2}{R_1 + R_2}}{1 + j\omega \frac{L}{R_1 + R_2}} \end{aligned}$$

When $R_1 = 4 \Omega$, $R_2 = 6 \Omega$ and $L = 8 \text{ H}$

$$\mathbf{H}(\omega) = \frac{0.6}{1 + j(0.8)\omega}$$

(checked using ELab on 8/6/02)

P13.3-4

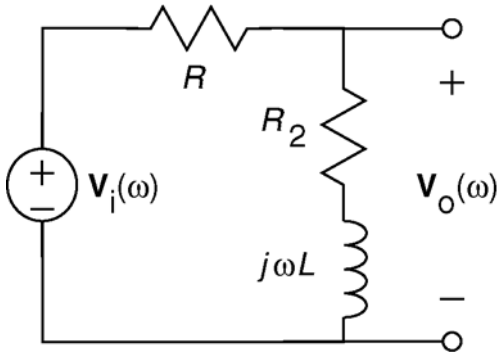

$$\begin{aligned} \mathbf{H}(\omega) &= \frac{\mathbf{V}_o(\omega)}{\mathbf{V}_i(\omega)} = \frac{R_2 + j\omega L}{R + R_2 + j\omega L} \\ &= \left(\frac{R_2}{R + R_2} \right) \left(\frac{1 + j\omega \frac{L}{R_2}}{1 + j\omega \frac{L}{R + R_2}} \right) \end{aligned}$$

Comparing the given and derived network functions, we require

$$\left(\frac{R_2}{R + R_2} \right) \left(\frac{1 + j\omega \frac{L}{R_2}}{1 + j\omega \frac{L}{R + R_2}} \right) = (0.6) \frac{1 + j\frac{\omega}{12}}{1 + j\frac{\omega}{20}} \Rightarrow \begin{cases} \frac{R_2}{R + R_2} = 0.6 \\ \frac{R_2}{L} = 12 \\ \frac{R + R_2}{L} = 20 \end{cases}$$

Since $R_2 = 60 \Omega$, we have $L = \frac{60}{12} = 5 \text{ H}$, then $R = (20)(5) - 60 = 40 \Omega$.

(checked using ELab on 8/6/02)

P13.3-5

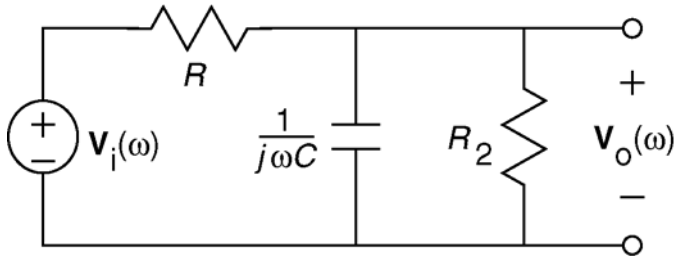

$$R_2 \parallel \frac{1}{j\omega C} = \frac{R_2}{1 + j\omega C R_2}$$

$$\mathbf{H}(\omega) = \frac{\mathbf{V}_o(\omega)}{\mathbf{V}_i(\omega)} = \frac{\frac{R_2}{1 + j\omega C R_2}}{R + \frac{R_2}{1 + j\omega C R_2}}$$

$$= \frac{R_2}{R + R_2} \cdot \frac{1 + j\omega C R_2}{1 + j\omega C R_2}$$

$$= \frac{R_2}{R + R_2} \cdot \frac{1 + j\omega C R_2}{1 + j\omega C R_p}$$

where $R_p = R \parallel R_2$.

Comparing the given and derived network functions, we require

$$\frac{\frac{R_2}{R + R_2}}{1 + j\omega C R_p} = \frac{0.2}{1 + j4\omega} \Rightarrow \begin{cases} \frac{R_2}{R + R_2} = 0.2 \\ C R_p = 4 \end{cases}$$

Since $R_2 = 2 \Omega$, we have $\frac{2}{R + 2} = 0.2 \Rightarrow R = 8 \Omega$. Then $R_p = \frac{(2)(8)}{2 + 8} = 1.6 \Omega$.

Finally, $C = \frac{4}{1.6} = 2.5 \text{ F}$.

(checked using ELab on 8/6/02)

P13.3-6

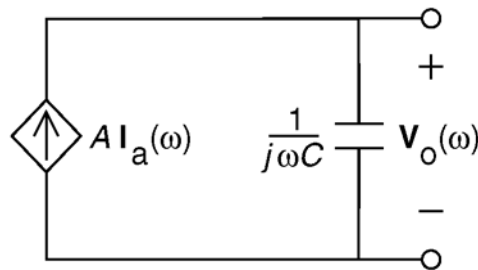
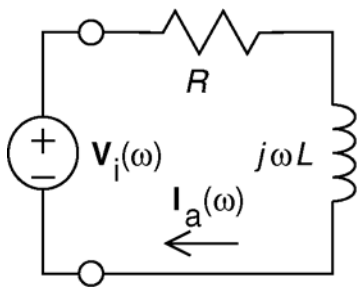

$$\left. \begin{aligned} \mathbf{I}_a(\omega) &= \frac{\mathbf{V}_i(\omega)}{R + j\omega L} \\ \mathbf{V}_o(\omega) &= \frac{1}{j\omega C} (A \mathbf{I}_a(\omega)) \end{aligned} \right\} \Rightarrow \frac{\mathbf{V}_o(\omega)}{\mathbf{V}_i(\omega)} = \frac{A}{(j\omega) \left(1 + j\omega \frac{L}{R} \right)}$$

When $R = 20 \Omega$, $L = 4 \text{ H}$, $A = 3 \text{ A/A}$ and $C = 0.25 \text{ F}$

$$\mathbf{H}(\omega) = \frac{0.6}{(j\omega)(1 + j(0.2)\omega)}$$

(checked using LNAP on 12/29/02)

P13.3-7

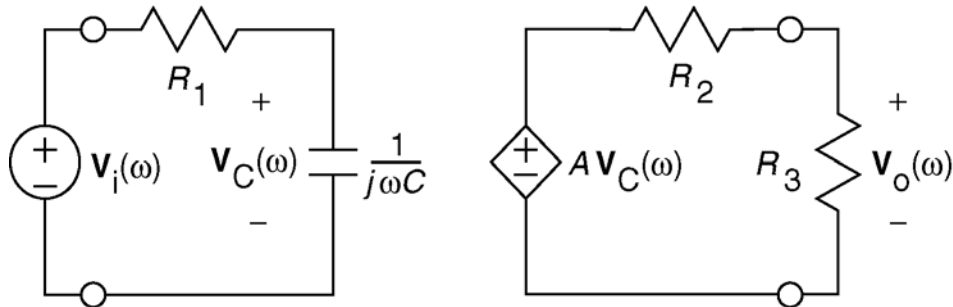

In the frequency domain, use voltage division on the left side of the circuit to get:

$$V_C(\omega) = \frac{\frac{1}{j\omega C}}{R_1 + \frac{1}{j\omega C}} V_i(\omega) = \frac{1}{1 + j\omega C R_1} V_i(\omega)$$

Next, use voltage division on the right side of the circuit to get:

$$V_o(\omega) = \frac{R_3}{R_2 + R_3} A V_C(\omega) = \frac{2}{3} A V_C(\omega) = \frac{\frac{2}{3} A}{1 + j\omega C R_1} V_i(\omega)$$

Compare the specified network function to the calculated network function:

$$\frac{4}{1 + j\frac{\omega}{100}} = \frac{\frac{2}{3} A}{1 + j\omega C R_1} = \frac{\frac{2}{3} A}{1 + j\omega C 2000} \Rightarrow 4 = \frac{2}{3} A \text{ and } \frac{1}{100} = 2000 C$$

Thus, $C = 5 \mu\text{F}$ and $A = 6 \text{ V/V}$.

(checked using ELab on 8/6/02)

P13.3-8

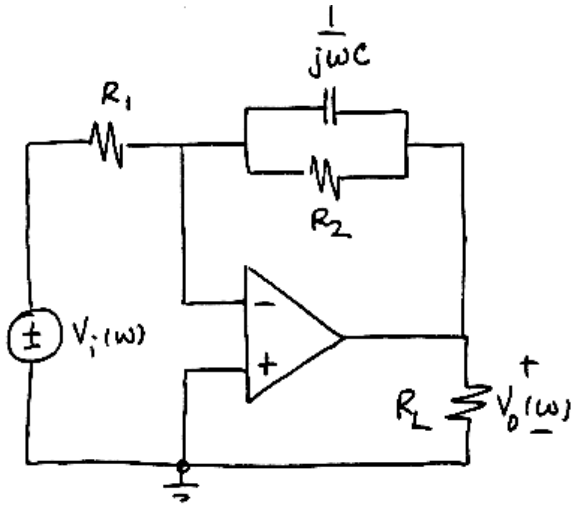

$$\mathbf{H}(\omega) = \frac{\mathbf{V}_o(\omega)}{\mathbf{V}_i(\omega)} = -\frac{R_2 \parallel \frac{1}{j\omega C}}{R_1}$$

$$= \frac{-\left(\frac{R_2}{R_1}\right)}{1+j\omega C R_2}$$

When $R_1 = 10 \text{ k}\Omega$, $R_2 = 50 \text{ k}\Omega$, and $C = 2 \mu\text{F}$, then

$$\frac{R_2}{R_1} = 5 \text{ and } R_2 C = \frac{1}{10} \text{ so } \mathbf{H}(\omega) = \frac{-5}{1+j\frac{\omega}{10}}$$

P13.3-9

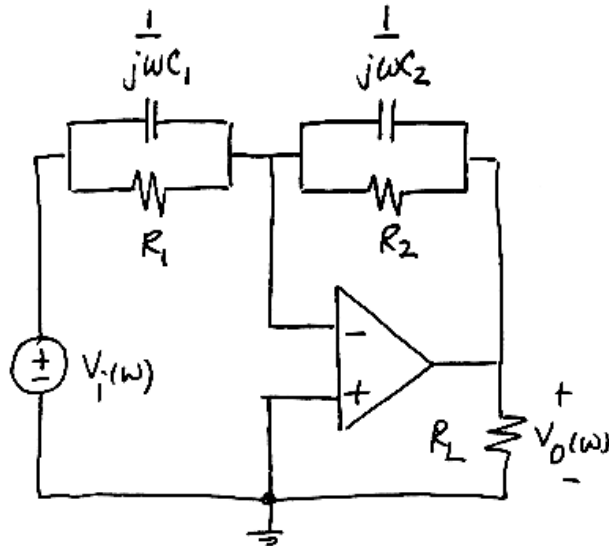

$$\mathbf{H}(\omega) = \frac{\mathbf{V}_o(\omega)}{\mathbf{V}_i(\omega)} = -\frac{R_2 \parallel \frac{1}{j\omega C_2}}{R_1 \parallel \frac{1}{j\omega C_1}}$$

$$= -\frac{\frac{R_2}{1+j\omega C_2 R_2}}{\frac{R_1}{1+j\omega C_1 R_1}}$$

$$\mathbf{H}(\omega) = -\left(\frac{R_2}{R_1}\right) \left(\frac{1+j\omega C_1 R_1}{1+j\omega C_2 R_2}\right)$$

When $R_1 = 10 \text{ k}\Omega$, $R_2 = 50 \text{ k}\Omega$, $C_1 = 4 \mu\text{F}$ and $C_2 = 2 \mu\text{F}$,

then $\frac{R_2}{R_1} = 5$, $C_1 R_1 = \frac{1}{25}$ and $C_2 R_2 = \frac{1}{10}$

so

$$\mathbf{H}(\omega) = -5 \left(\frac{1+j\frac{\omega}{25}}{1+j\frac{\omega}{10}} \right)$$

$$\text{gain} = |\mathbf{H}(\omega)| = (5) \frac{\sqrt{1 + \frac{\omega^2}{625}}}{\sqrt{1 + \frac{\omega^2}{100}}}$$

$$\text{phase shift} = \angle \mathbf{H}(\omega) = 180 + \tan^{-1}\left(\frac{\omega}{25}\right) - \tan^{-1}\left(\frac{\omega}{10}\right)$$

P13.3-10

$$R_3 \parallel \frac{1}{j\omega C} = \frac{R_3 \frac{1}{j\omega C}}{R_3 + \frac{1}{j\omega C}} = \frac{R_1}{1 + j\omega C R_3}$$

$$\mathbf{H}(\omega) = -\frac{R_2 + \frac{R_3}{1 + j\omega C R_3}}{R_1} = -\frac{R_2 + R_3 + j\omega R_2 R_3 C}{R_1 + j\omega R_1 R_3 C}$$

$$5 = \lim_{\omega \rightarrow 0} |\mathbf{H}(\omega)| = \frac{R_2 + R_3}{R_1}$$

$$2 = \lim_{\omega \rightarrow \infty} |\mathbf{H}(\omega)| = \frac{R_2}{R_1} \Rightarrow R_2 = 2R_1 = 20 \text{ k}\Omega$$

$$\text{then } R_3 = 5R_1 - R_2 = 30 \text{ k}\Omega$$

P13.3-11

$$\mathbf{H}(\omega) = -\frac{R_2 + \frac{1}{j\omega C}}{R_1} = -\frac{1 + j\omega C R_2}{j\omega C R_1}$$

$$\angle \mathbf{H}(\omega) = 180^\circ + \tan^{-1} \omega C R_2 - 90^\circ$$

$$\angle \mathbf{H}(\omega) = 135^\circ \Rightarrow \tan^{-1} \omega C R_2 = 45^\circ \Rightarrow \omega C R_2 = 1$$

$$\Rightarrow R_2 = \frac{1}{10^3 10^{-7}} = 10 \text{ k}\Omega$$

$$10 = \lim_{\omega \rightarrow \infty} |\mathbf{H}(\omega)| = \frac{R_2}{R_1} \Rightarrow R_1 = \frac{R_2}{10} = 1 \text{ k}\Omega$$

P13.3-12

$$\mathbf{H}(\omega) = \frac{-R_2}{\frac{1}{j\omega C}} = -\frac{j\omega C R_2}{1+j\omega C R_1}$$

$$10 = \lim_{\omega \rightarrow \infty} |\mathbf{H}(\omega)| = \frac{R_2}{R_1} \Rightarrow R_2 = 10R_1$$

$$\angle \mathbf{H}(\omega) = 180^\circ + 90^\circ - \tan^{-1} \omega C R_1$$

$$\Rightarrow R_1 = \frac{\tan(270^\circ - \angle \mathbf{H}(\omega))}{\omega C} = 10^4 \cdot \tan(270^\circ - \angle \mathbf{H}(\omega)) = 10^4 = 10 \text{ k}\Omega$$

$$\Rightarrow R_2 = 100 \text{ k}\Omega$$

P13.3-13

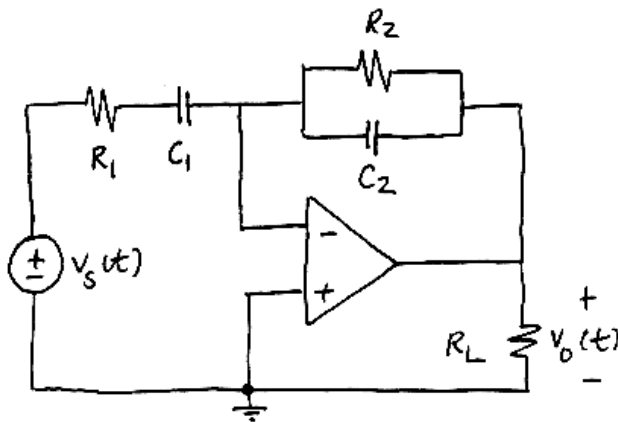

$$\begin{aligned} \mathbf{H}(\omega) &= \frac{\mathbf{V}_o(\omega)}{\mathbf{V}_s(\omega)} = -\frac{R_2 \parallel \frac{1}{j\omega C_2}}{R_1 + \frac{1}{j\omega C_1}} \\ &= \frac{(-C_1 R_2) j\omega}{(1 + j\omega R_1 C_1)(1 + j\omega R_2 C_2)} \end{aligned}$$

When $R_1 = 5 \text{ k}\Omega$, $C_1 = 1 \mu\text{F}$,
 $R_2 = 10 \text{ k}\Omega$ and $C_2 = 0.1 \mu\text{F}$,
 then

$$\mathbf{H}(\omega) = \frac{(-0.01) j\omega}{\left(1 + j\frac{\omega}{200}\right) \left(1 + j\frac{\omega}{1000}\right)}$$

so

ω	$ \mathbf{H}(\omega) $	$\angle \mathbf{H}(\omega)$
0	0	-90°
500	1.66	175°
2500	0.74	116°

Then

$$\begin{aligned} v_o(t) &= (0) 50 + (1.66)(30) \cos(500t + 115^\circ + 175^\circ) - (0.74)(20) \cos(2500t + 30^\circ + 116^\circ) \\ &= 49.8 \cos(500t - 70^\circ) - 14.8 \cos(2500t + 146^\circ) \text{ mV} \end{aligned}$$

When $R_1 = 5 \text{ k}\Omega$, $C_1 = 1 \mu\text{F}$, $R_2 = 10 \text{ k}\Omega$ and $C_2 = 0.01 \mu\text{F}$, then

$$\mathbf{H}(\omega) = -0.01 \frac{j\omega}{\left(1 + j\frac{\omega}{200}\right)\left(1 + j\frac{\omega}{10,000}\right)}$$

So

ω	$ \mathbf{H}(\omega) $	$\angle\mathbf{H}(\omega)$
0	0	-90°
500	1.855	-161°
2500	1.934	170°

Then

$$\begin{aligned} v_o(t) &= (0)(50) + (1.855)(30)\cos(500t + 115^\circ - 161^\circ) - (1.934)(20)\cos(2500t + 30^\circ + 170^\circ) \\ &= 55.65 \cos(500t - 46^\circ) - 38.68 \cos(2500t + 190^\circ) \text{ mV} \end{aligned}$$

P13.3-14

a)

$$|V_s| = \frac{(8 \text{ div})\left(\frac{2 \text{ V}}{\text{div}}\right)}{2} = 8 \text{ V}$$

$$|V_o| = \frac{(6.2 \text{ div})\left(\frac{2 \text{ V}}{\text{div}}\right)}{2} = 6.2 \text{ V}$$

$$\text{gain} = \frac{|V_o|}{|V_s|} = \frac{6.2}{8} = 0.775$$

b)

$$\mathbf{H}(\omega) = \frac{V_o(\omega)}{V_s(\omega)} = \frac{\frac{1}{j\omega C}}{R + \frac{1}{j\omega C}} = \frac{1}{1 + j\omega C R}$$

$$\text{Let } g = |\mathbf{H}(\omega)| = \frac{1}{\sqrt{1 + \omega^2 C^2 R^2}} \text{ then } C = \frac{1}{\omega R} \sqrt{\left(\frac{1}{g}\right)^2 - 1}$$

In this case $\omega = 2\pi \cdot 500 = 3142 \text{ rad/s}$,

$|\mathbf{H}(\omega)| = 0.775$ and $R = 1000 \Omega$ so $C = 0.26 \mu\text{F}$.

c)

$$\angle \mathbf{H}(\omega) = -\tan^{-1} \omega R C \text{ so } \omega = \frac{\tan(-\angle \mathbf{H}(\omega))}{R C}$$

Recalling that $R = 1000 \Omega$ and $C = 0.26 \mu\text{F}$, we calculate

ω	$ \mathbf{H}(\omega) $	$\angle \mathbf{H}(\omega)$
$2\pi(200)$	0.95	-18°
$2\pi(2000)$	0.26	-73°

$$\angle \mathbf{H}(\omega) = -45^\circ \text{ requires } \omega = \frac{\tan\left(-(-45^\circ)\right)}{(1000)(.26 \times 10^{-6})} = 3846 \text{ rad/s}$$

$$\angle \mathbf{H}(\omega) = -135^\circ \text{ requires } \omega = \frac{\tan(-(-135^\circ))}{(1000)(0.26 \times 10^{-6})} = -3846 \text{ rad/s}$$

A negative frequency is not acceptable. We conclude that this circuit cannot produce a phase shift equal to -135° .

$$d) \quad C = \frac{\tan(-\angle \mathbf{H}(\omega))}{\omega R} \Rightarrow \begin{cases} C = \frac{\tan(-60^\circ)}{(2\pi \cdot 500)(1000)} = 0.55 \mu\text{F} \\ C = \frac{\tan(-(-300^\circ))}{(2\pi \cdot 500)(1000)} = -0.55 \mu\text{F} \end{cases}$$

A negative value of capacitance is not acceptable and indicates that this circuit cannot be designed to produce a phase shift at -300° at a frequency of 500 Hz.

$$e) \quad C = \frac{\tan(-(-120^\circ))}{(2\pi \cdot 500)(100)} = -0.55 \mu\text{F}$$

This circuit cannot be designed to produce a phase shift of -120° at 500 Hz.

Section 13-4: Bode Plots

P13.4-1

$$\mathbf{H}(\omega) = \frac{20 \left(1 + j \frac{\omega}{5}\right)}{\left(1 + j \frac{\omega}{50}\right)} \approx \begin{cases} 20 & \omega < 5 \\ 20 \left(j \frac{\omega}{5}\right) & 5 < \omega < 50 \\ \frac{20 \left(j \frac{\omega}{5}\right)}{\left(j \frac{\omega}{50}\right)} = 200 & 50 < \omega \end{cases}$$

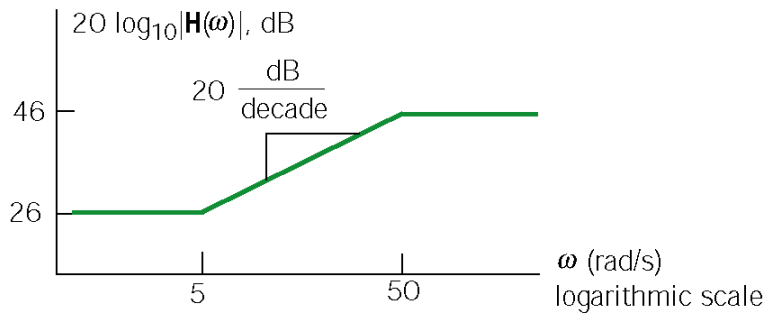

P13.4-2

$$\mathbf{H}_1(\omega) = \frac{1 + j \frac{\omega}{5}}{1 + j \frac{\omega}{50}} \quad \mathbf{H}_2(\omega) = 10 \frac{1 + j \frac{\omega}{5}}{1 + j \frac{\omega}{50}}$$

Both $\mathbf{H}_1(\omega)$ and $\mathbf{H}_2(\omega)$ have a pole at $\omega = 50$ rad/s and a zero at $\omega = 5$ rad/s. The slopes of both magnitude Bode plots increase by 20 dB/decade at $\omega = 5$ rad/s and decrease by 20 dB/decade at $\omega = 50$ rad/s. The difference is that for $\omega < 5$ rad/s

$$|\mathbf{H}_1(\omega)| \approx 1 = 0 \text{ dB} \quad \text{and} \quad |\mathbf{H}_2(\omega)| \approx 10 = 20 \text{ dB}$$

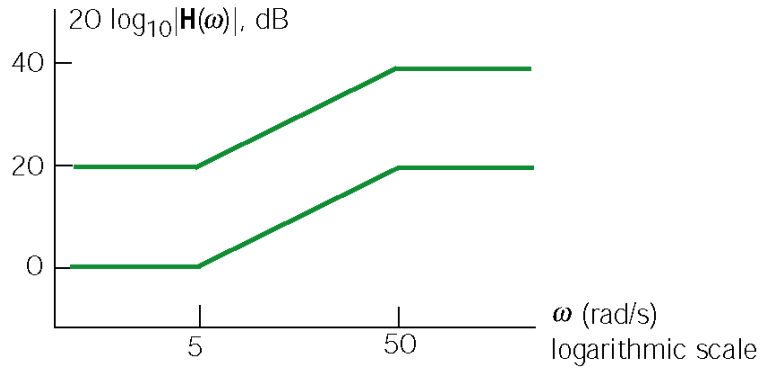

P13.4-3

$$\mathbf{H}(\omega) = -\frac{\frac{R_2}{1+j\omega C_2 R_2}}{R_1 + \frac{1}{j\omega C_1}} = -C_1 R_2 \frac{j\omega}{(1+j\omega R_1 C_1)(1+j\omega R_2 C_2)}$$

This network function has poles at

$$p_1 = \frac{1}{R_1 C_1} = 2000 \text{ rad/s} \text{ and } p_2 = \frac{1}{R_2 C_2} = 1000 \text{ rad/s}$$

so

$$\mathbf{H}(\omega) \approx \begin{cases} (C_1 R_2) j\omega & \omega < p_1 \\ (C_1 R_2) \frac{j\omega}{j\omega C_1 R_1} = \frac{R_2}{R_1} = 2 & p_1 < \omega < p_2 \\ (C_1 R_2) \frac{j\omega}{(j\omega C_1 R_1)(j\omega C_2 R_2)} = \frac{1}{j\omega C_2 R_1} & \omega > p_2 \end{cases}$$

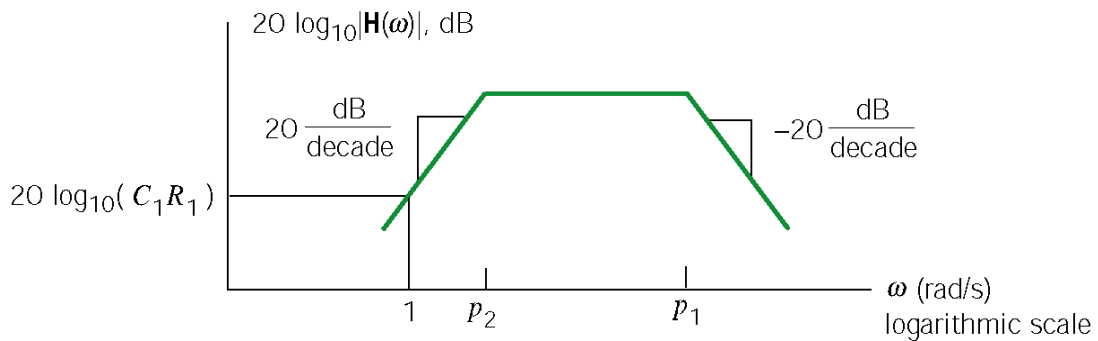

P13.4-4

$$\mathbf{H}(\omega) = -\frac{\frac{R_2}{1+j\omega C_2 R_2}}{\frac{R_1}{1+j\omega C_1 R_1}} = -\frac{R_2(1+j\omega C_1 R_1)}{R_1(1+j\omega C_2 R_2)} \quad \text{so } K = -\frac{R_2}{R_1}, \quad z = \frac{1}{C_1 R_1} \quad \text{and } p = \frac{1}{C_2 R_2}$$

When $z < p$

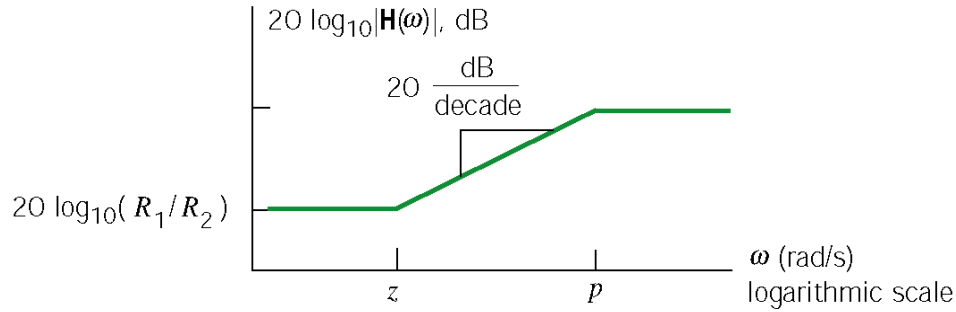

When $z > p$

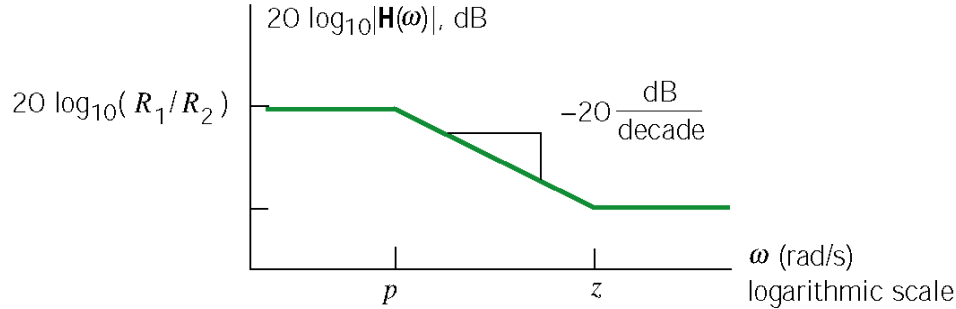

P13.4-5

Using voltage division twice gives:

$$\frac{\mathbf{V}_2(\omega)}{\mathbf{V}_i(\omega)} = \frac{\frac{j\omega L R_2}{R_2 + j\omega L}}{R_1 + \frac{j\omega L R_2}{R_2 + j\omega L}} = \frac{j\omega L R_2}{R_1 R_2 + j\omega L(R_1 + R_2)} = \frac{L}{R_1} \frac{j\omega}{1 + j\omega \frac{L(R_1 + R_2)}{R_1 R_2}}$$

and

$$\frac{\mathbf{V}_o(\omega)}{\mathbf{V}_2(\omega)} = \frac{\frac{R_4}{R_3 + j\omega C R_4}}{R_3 + \frac{R_4}{R_3 + j\omega C R_4}} A = \frac{A R_4}{R_3 + R_4 + j\omega C R_3 R_4} = \frac{\frac{A R_4}{R_3 + R_4}}{1 + j\omega \frac{C R_3 R_4}{R_3 + R_4}}$$

Combining these equations gives

$$\mathbf{H}(\omega) = \frac{\mathbf{V}_o(\omega)}{\mathbf{V}_i(\omega)} = \frac{ALR_4}{R_1(R_3 + R_4)} \frac{j\omega}{\left(1 + j\omega \frac{L(R_1 + R_2)}{R_1R_2}\right) \left(1 + j\omega \frac{CR_3R_4}{R_3 + R_4}\right)}$$

The Bode plot corresponds to the network function:

$$\mathbf{H}(\omega) = \frac{k j\omega}{\left(1 + j\frac{\omega}{p_1}\right) \left(1 + j\frac{\omega}{p_2}\right)} = \frac{k j\omega}{\left(1 + j\frac{\omega}{200}\right) \left(1 + j\frac{\omega}{20000}\right)}$$

$$\mathbf{H}(\omega) \approx \begin{cases} \frac{k j\omega}{1 \cdot 1} = k j\omega & \omega \leq p_1 \\ \frac{k j\omega}{j\omega \cdot 1} = k p_1 & p_1 \leq \omega \leq p_2 \\ \frac{k j\omega}{j\omega \cdot j\omega} = \frac{k p_1 p_2}{j\omega} & \omega \geq p_2 \end{cases}$$

This equation indicates that $|\mathbf{H}(\omega)| = k p_1$ when $p_1 \leq \omega \leq p_2$. The Bode plot indicates that $|\mathbf{H}(\omega)| = 20 \text{ dB} = 10$ when $p_1 \leq \omega \leq p_2$. Consequently

$$k = \frac{10}{p_1} = \frac{10}{200} = 0.05$$

Finally,

$$\mathbf{H}(\omega) = \frac{0.05 j\omega}{\left(1 + j\frac{\omega}{200}\right) \left(1 + j\frac{\omega}{20000}\right)}$$

Comparing the equation for $\mathbf{H}(\omega)$ obtained from the circuit to the equation for $\mathbf{H}(\omega)$ obtained from the Bode plot gives:

$$0.05 = \frac{ALR_4}{R_1(R_3 + R_4)}, \quad 200 = \frac{R_1R_2}{L(R_1 + R_2)} \text{ and } 20000 = \frac{R_3 + R_4}{CR_3R_4}$$

Pick $L = 1 \text{ H}$, and $R_1 = R_2$, then $R_1 = R_2 = 400 \Omega$. Let $C = 0.1 \mu\text{F}$ and $R_3 = R_4$, then $R_3 = R_4 = 1000 \Omega$. Finally, $A=40$. (Checked using ELab 3/5/01)

P13.4-6

From Table 13.4-2:

$$\frac{R_2}{R_1} = k = 32 \text{ dB} = 40 \quad R_2 = 40(10 \times 10^3) = 400 \text{ k}\Omega$$

$$\frac{1}{C_2 R_2} = p = 400 \text{ rad/s} \Rightarrow C_2 = \frac{1}{(400)(400 \times 10^3)} = 6.25 \text{ nF}$$

$$\frac{1}{C_1 R_1} = z = 4000 \text{ rad/s} \Rightarrow C_1 = \frac{1}{(4000)(10 \times 10^3)} = 25 \text{ nF}$$

P13.4-7

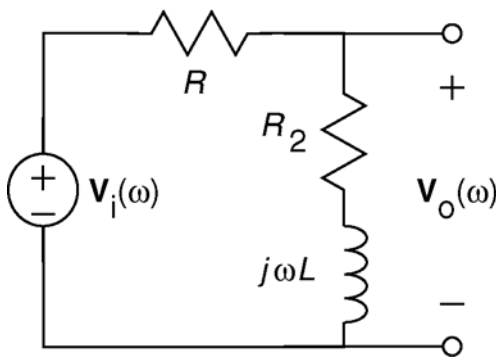

$$\begin{aligned} \mathbf{H}(\omega) &= \frac{\mathbf{V}_o(\omega)}{\mathbf{V}_i(\omega)} = \frac{R_2 + j\omega L}{R + R_2 + j\omega L} \\ &= \left(\frac{R_2}{R + R_2} \right) \left(\frac{1 + j\omega \frac{L}{R_2}}{1 + j\omega \frac{L}{R + R_2}} \right) \end{aligned}$$

$$\mathbf{H}(\omega) = \frac{(0.2)(1 + j(0.25)\omega)}{1 + j(0.05)\omega} \Rightarrow \begin{cases} k = 0.2 \\ z = \frac{1}{0.25} = 4 \\ p = \frac{1}{0.05} = 20 \end{cases}$$

P13.4-8

- The slope is 40dB/decade for low frequencies, so the numerator will include the factor $(j\omega)^2$.
- The slope decreases by 40 dB/decade at $\omega = 0.7$ rad/sec. So there is a second order pole at $\omega_0 = 0.7$ rad/s. The damping factor of this pole cannot be determined from the asymptotic Bode plot; call it δ_1 . The denominator of the network function will contain the factor

$$1 + 2\delta_1 j \frac{\omega}{0.7} - \left(\frac{\omega}{0.7} \right)^2$$

- The slope increases by 20 dB/decade at $\omega = 10$ rad/s, indicating a zero at 10 rad/s.

- The slope decreases by 20 dB/decade at $\omega = 100$ rad/s, indicating a pole at 100 rad/s.
- The slope decreases by 40 dB/decade at $\omega = 600$ rad/s, indicating a second order pole at $\omega_0 = 600$ rad/s. The damping factor of this pole cannot be determined from an asymptotic Bode plot; call it δ_2 . The denominator of the network function will contain the factor

$$1 + 2\delta_2 j \frac{\omega}{600} - \left(\frac{\omega}{600}\right)^2$$

$$\mathbf{H}(\omega) = \frac{K(1+j\frac{\omega}{10})(j\omega)^2}{\left(1+2\delta_1 j \frac{\omega}{0.7} - \left(\frac{\omega}{0.7}\right)^2\right) \left(1+2\delta_2 j \frac{\omega}{600} - \left(\frac{\omega}{600}\right)^2\right) \left(1+j\frac{\omega}{100}\right)}$$

To determine K , notice that $|\mathbf{H}(\omega)| = 0 \text{ dB} = 1$ when $0.7 < \omega < 10$. That is

$$1 = \frac{K(1)(j\omega)^2}{-\left(\frac{\omega}{0.7}\right)^2 (1)(1)} = K(0.7)^2 \Rightarrow K = 2$$

P13.4-9

(a)

$$\mathbf{H}(\omega) = \frac{K\left(1+j\frac{\omega}{z}\right)}{j\omega}$$

$$|\mathbf{H}(\omega)| = \frac{K}{\omega} \sqrt{1+\left(\frac{\omega}{z}\right)^2}$$

$$|\mathbf{H}(\omega)| \text{ dB} = 20 \log_{10} \frac{K}{\omega} \sqrt{1+\left(\frac{\omega}{z}\right)^2}$$

$$= 20 \log_{10} K - 20 \log_{10} \omega + 20 \log_{10} \sqrt{1+\left(\frac{\omega}{z}\right)^2}$$

$$\text{Let } |\mathbf{H}_L(\omega)| \text{ dB} = 20 \log_{10} K - 20 \log_{10} \omega$$

$$\text{and } |\mathbf{H}_H(\omega)| \text{ dB} = 20 \log_{10} \frac{K}{z}$$

$$\text{Then } |\mathbf{H}(\omega)| \text{ dB} \simeq \begin{cases} |\mathbf{H}_L(\omega)| \text{ dB} & \omega \ll z \\ |\mathbf{H}_H(\omega)| \text{ dB} & \omega \gg z \end{cases}$$

So $|\mathbf{H}_L(\omega)|$ dB and $|\mathbf{H}_H(\omega)|$ dB are the required low and high-frequency asymptotes.

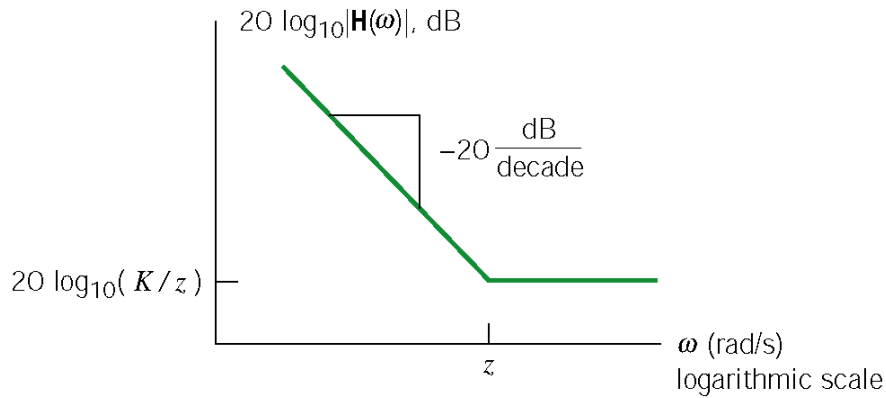

The Bode plot will be within 1% of $|\mathbf{H}(\omega)|$ dB both for $\omega \ll z$ and for $\omega \gg z$. The range when $\omega \ll z$ is characterized by

$$|\mathbf{H}_L(\omega)| = 0.99|\mathbf{H}(\omega)| \quad (\text{gains not in dB})$$

or equivalently

$$\begin{aligned} 20 \log_{10}(0.99) &= |\mathbf{H}_L(\omega)| \text{ dB} - |\mathbf{H}(\omega)| \text{ dB} \quad (\text{gains in dB}) \\ &= 20 \log_{10} K - 20 \log_{10} \omega - 20 \log_{10} \frac{K}{\omega} \sqrt{1 + \left(\frac{\omega}{z}\right)^2} \\ &= -20 \log_{10} \sqrt{1 + \left(\frac{\omega}{z}\right)^2} = 20 \log_{10} \frac{1}{\sqrt{1 + \left(\frac{\omega}{z}\right)^2}} \end{aligned}$$

Therefore

$$0.99 = \frac{1}{\sqrt{1 + \left(\frac{\omega}{z}\right)^2}} \Rightarrow \omega = z \sqrt{\left(\frac{1}{0.99}\right)^2 - 1} = 0.14z \approx \frac{z}{7}$$

The range when $\omega \gg z$ is characterized by

$$|\mathbf{H}_H(\omega)| = .99|\mathbf{H}(\omega)| \quad (\text{gains not in dB})$$

or equivalently

$$\begin{aligned}
20 \log_{10} 0.99 &= |\mathbf{H}_H(\omega)| \text{ dB} - |\mathbf{H}(\omega)| \text{ dB} && \text{(gains in dB)} \\
&= 20 \log_{10} K - 20 \log_{10} z - 20 \log_{10} \frac{K}{\omega} \sqrt{1 + \left(\frac{\omega}{z}\right)^2} \\
&= -20 \log_{10} \frac{z}{\omega} \sqrt{1 + \left(\frac{\omega}{z}\right)^2} = 20 \log_{10} \frac{1}{\sqrt{\left(\frac{z}{\omega}\right)^2 + 1}}
\end{aligned}$$

Therefore

$$\frac{z}{\omega} = \sqrt{\left(\frac{1}{.99}\right)^2 - 1} \Rightarrow \omega = \frac{z}{\sqrt{\left(\frac{1}{.99}\right)^2 - 1}} = \frac{z}{0.14} \approx 7z$$

The error is less than 1% when $\omega < \frac{z}{7}$ and when $\omega > 7z$.

P13.4-10

$$\begin{aligned}
\mathbf{H}(\omega) &= \frac{\mathbf{V}_o(\omega)}{\mathbf{V}_s(\omega)} = \frac{R_t}{R_t + R_1 \parallel \frac{1}{j\omega C}} = \frac{R_t}{R_t + \frac{R_1}{1 + j\omega C R_1}} \\
&= \frac{R_t(1 + j\omega C R_1)}{R_t + R_1 + j\omega C R_1 R_t} = \left(\frac{R_t}{R_t + R_1}\right) \frac{1 + j\omega C R_1}{1 + j\omega \left(\frac{C R_1 R_t}{R_t + R_1}\right)}
\end{aligned}$$

When $R_1 = 1 \text{ k}\Omega$, $C = 1 \text{ }\mu\text{F}$ and $R_t = 5 \text{ k}\Omega$

$$\mathbf{H}(\omega) = \frac{5}{6} \left(\frac{1 + j\frac{\omega}{1000}}{1 + j\frac{\omega}{1200}} \right) \Rightarrow \mathbf{H}(\omega) \cong \begin{cases} \frac{5}{6} & \omega < 1000 \\ \left(\frac{5}{6}\right) j \frac{\omega}{1000} & 1000 < \omega < 1200 \\ 1 & \omega > 1200 \end{cases}$$

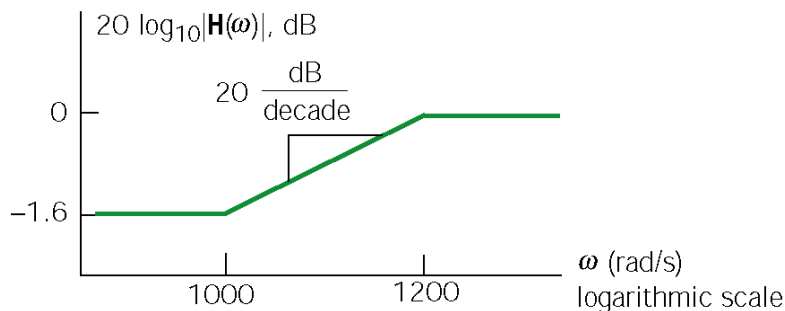

P13.4-11

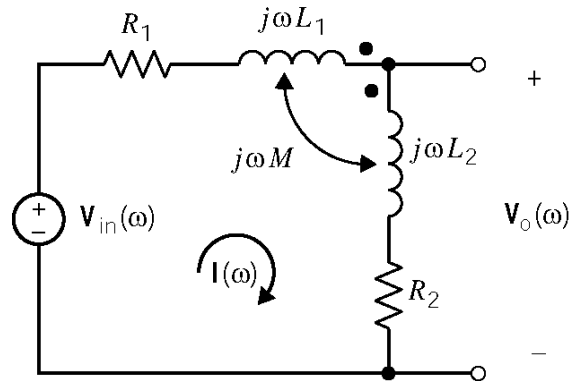

Mesh equations:

$$\mathbf{V}_{in}(\omega) = \mathbf{I}(\omega) [R_1 + (j\omega L_1 - j\omega M) + (-j\omega M + j\omega L_2) + R_2]$$

$$\mathbf{V}_o(\omega) = \mathbf{I}(\omega) [(-j\omega M + j\omega L_2) + R_2]$$

Solving yields:

$$\mathbf{H}(\omega) = \frac{\mathbf{V}_o(\omega)}{\mathbf{V}_{in}(\omega)} = \frac{R_2 + j\omega(L_2 - M)}{R_1 + R_2 + j\omega(L_1 + L_2 - 2M)}$$

Comparing to the given Bode plot yields:

$$K_1 = \lim_{\omega \rightarrow \infty} |\mathbf{H}(\omega)| = \frac{L_2 - M}{L_1 + L_2 - 2M} = 0.75 \quad \text{and} \quad K_2 = \lim_{\omega \rightarrow 0} |\mathbf{H}(\omega)| = \frac{R_2}{R_1 + R_2} = 0.2$$

$$z = \frac{R_2}{L_2 - M} = 333 \text{ rad/s} \quad \text{and} \quad p = \frac{R_1 + R_2}{L_1 + L_2 - 2M} = 1250 \text{ rad/s}$$

P13.4-12

$$\mathbf{H}(\omega) = -\frac{\frac{1}{j\omega C_2}}{R_1 \parallel \frac{1}{j\omega C_1}} = -\frac{1+j\omega R_1 C_1}{j\omega R_1 C_2} = -\frac{1}{R_1 C_2} \frac{(1+j\omega R_1 C_1)}{j\omega}$$

$$\mathbf{H}(\omega) \approx \begin{cases} -\frac{1}{R_1 C_2} \left(\frac{1}{j\omega} \right) & \omega < \frac{1}{R_1 C_1} \\ -\frac{1}{R_1 C_2} (R_1 C_1) = -\frac{C_1}{C_2} & \omega > \frac{1}{R_1 C_1} \end{cases}$$

With the given values:

$$\frac{C_1}{C_2} = \frac{1}{2} = -6 \text{ dB}, \quad \frac{1}{R_1 C_1} = 4000 \text{ rad/s}$$

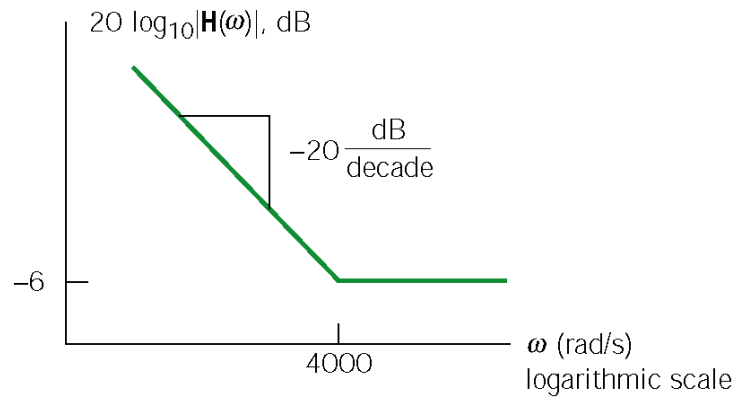

P13.4-13

Pick the appropriate circuit from Table 13.4-2.

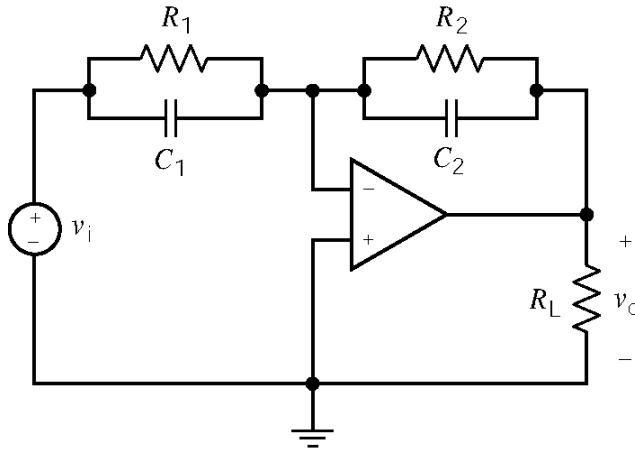

$$\mathbf{H}(\omega) = -k \frac{1 + j \frac{\omega}{z}}{1 + j \frac{\omega}{p}}$$

where

$$k = \frac{R_2}{R_1}$$

$$z = \frac{1}{C_1 R_1}$$

$$p = \frac{1}{C_2 R_2}$$

We require

$$200 = z = \frac{1}{C_1 R_1}, \quad 500 = p = \frac{1}{C_2 R_2} \quad \text{and} \quad 14 \text{ dB} = 5 = k \frac{p}{z} = \frac{C_1}{C_2}$$

Pick $C_1 = 1 \mu\text{F}$, then $C_2 = 0.2 \mu\text{F}$, $R_1 = 5 \text{ k}\Omega$ and $R_2 = 10 \text{ k}\Omega$.

P13.4-14

Pick the appropriate circuit from Table 13.4-2.

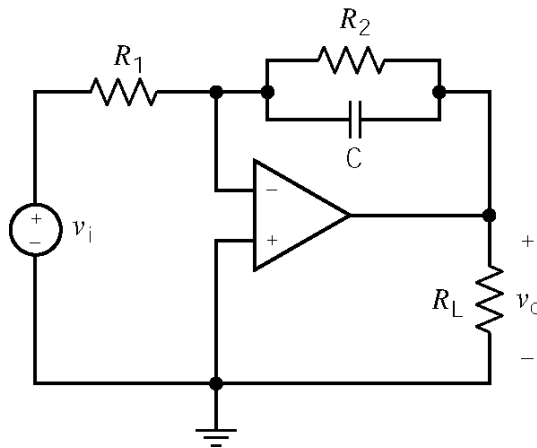

$$\mathbf{H}(\omega) = -\frac{k}{1 + j \frac{\omega}{p}}$$

where

$$k = \frac{R_2}{R_1}$$

$$p = \frac{1}{C R_2}$$

We require

$$500 = p = \frac{1}{C R_2} \quad \text{and} \quad 34 \text{ dB} = 50 = \frac{R_2}{R_1}$$

Pick $C = 0.1 \mu\text{F}$, then $R_2 = 20 \text{ k}\Omega$ and $R_1 = 400 \Omega$.

P13.4-15

Pick the appropriate circuit from Table 13.4-2.

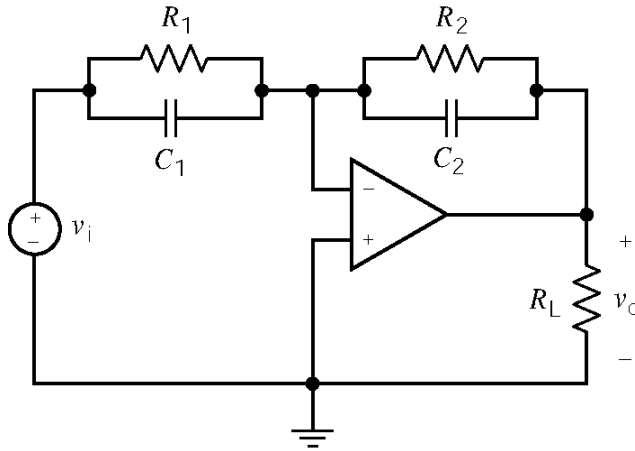

$$\mathbf{H}(\omega) = -k \frac{1 + j \frac{\omega}{z}}{1 + j \frac{\omega}{p}}$$

where

$$k = \frac{R_2}{R_1}$$

$$z = \frac{1}{C_1 R_1}$$

$$p = \frac{1}{C_2 R_2}$$

We require

$$500 = z = \frac{1}{C_1 R_1}, \quad 200 = p = \frac{1}{C_2 R_2} \quad \text{and} \quad 14 \text{ dB} = 5 = k \frac{p}{z} = \frac{C_1}{C_2}$$

Pick $C_1 = 0.1 \mu\text{F}$, then $C_2 = 0.05 \mu\text{F}$, $R_1 = 20 \text{ k}\Omega$ and $R_2 = 100 \text{ k}\Omega$.

P13.4-16

Pick the appropriate circuit from Table 13.4-2.

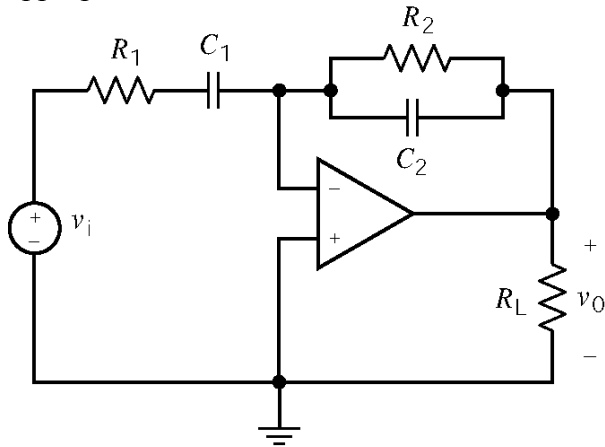

$$H(\omega) = - \frac{k(j\omega)}{\left(1 + j\frac{\omega}{p_1}\right)\left(1 + j\frac{\omega}{p_2}\right)}$$

where $k = C_1 R_2$

$$p_1 = \frac{1}{C_1 R_1}$$

$$p_2 = \frac{1}{C_2 R_2}$$

We require

$$200 = p_1 = \frac{1}{C_1 R_1}, \quad 200 = p_2 = \frac{1}{C_2 R_2} \quad \text{and} \quad 34 \text{ dB} = 50 = k = C_1 R_2$$

Pick $C_1 = 1 \mu\text{F}$, then $C_2 = 0.04 \mu\text{F}$, $R_1 = 5 \text{ k}\Omega$ and $R_2 = 50 \text{ k}\Omega$.

P13.4-17

$$H(\omega) = \frac{10(1+j\omega/50)}{(1+j\omega/2)(1+j\omega/20)(1+j\omega/80)}$$

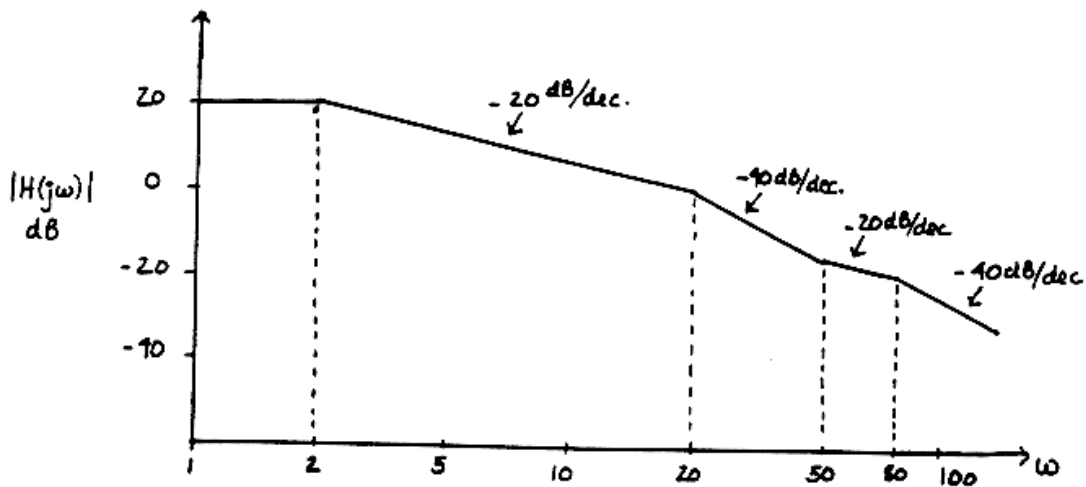

$$\phi = \angle \mathbf{H}(\omega) = \tan^{-1}(\omega/50) - (\tan^{-1}(\omega/2) + \tan^{-1}(\omega/20) + \tan^{-1}(\omega/80))$$

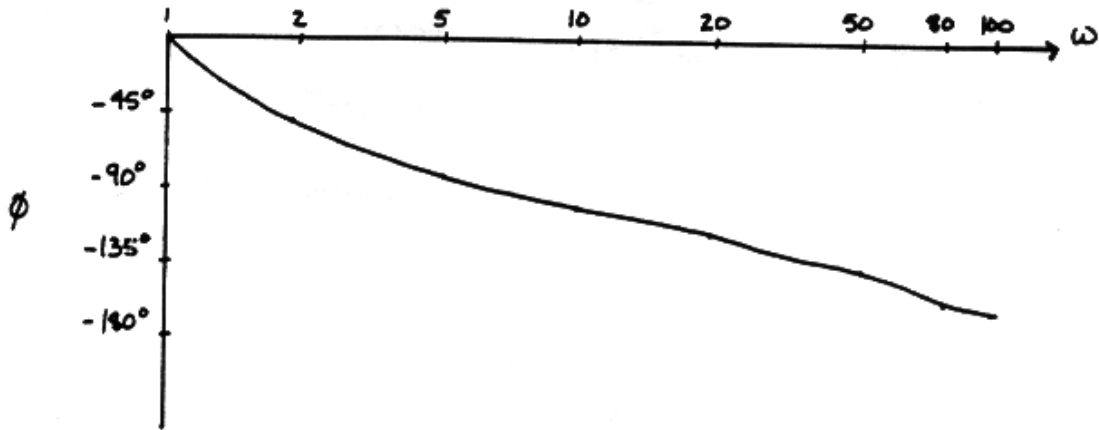

P13.4-18

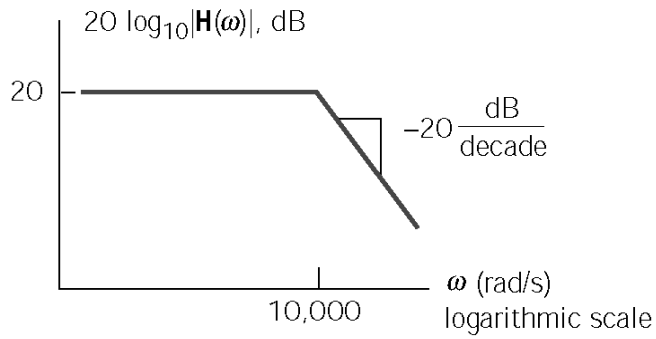

(a)
$$\mathbf{H}(\omega) = \frac{\mathbf{V}_o(\omega)}{\mathbf{V}_s(\omega)} = -\frac{R_2/R_1}{1+j\omega R_2 C}$$

$$= -\frac{10}{1+j\frac{\omega}{10,000}}$$

(b) $10 = 20 \text{ dB}$

(c) $10,000 \text{ rad/s}$

P13.4-19

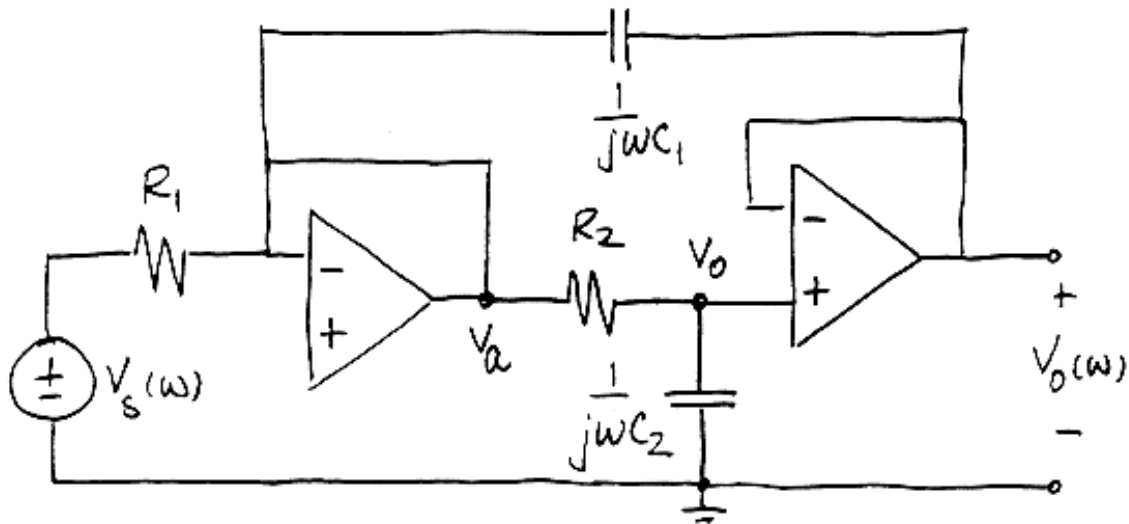

$$\left. \begin{aligned} V_o(\omega) &= \frac{1}{R + \frac{1}{j\omega C_2}} V_a(\omega) \\ 0 &= \frac{V_a(\omega) - V_s(\omega)}{R_1} + j\omega C_1 (V_a(\omega) - V_o(\omega)) \end{aligned} \right\} \Rightarrow V_o(1 + j\omega C_1 R_1)(1 + j\omega C_2 R_2) = j\omega C_1 R_1 V_o + V_s$$

$$T(\omega) = \frac{V_o(\omega)}{V_s(\omega)} = \frac{1}{1 + C_2 R_2 j\omega - \omega^2 C_1 C_2 R_1 R_2} = \frac{1}{-\omega^2 + 0.8j\omega + 1}$$

This is a second order transfer function with $\omega_o = 0$ and $\delta = 0.4$.

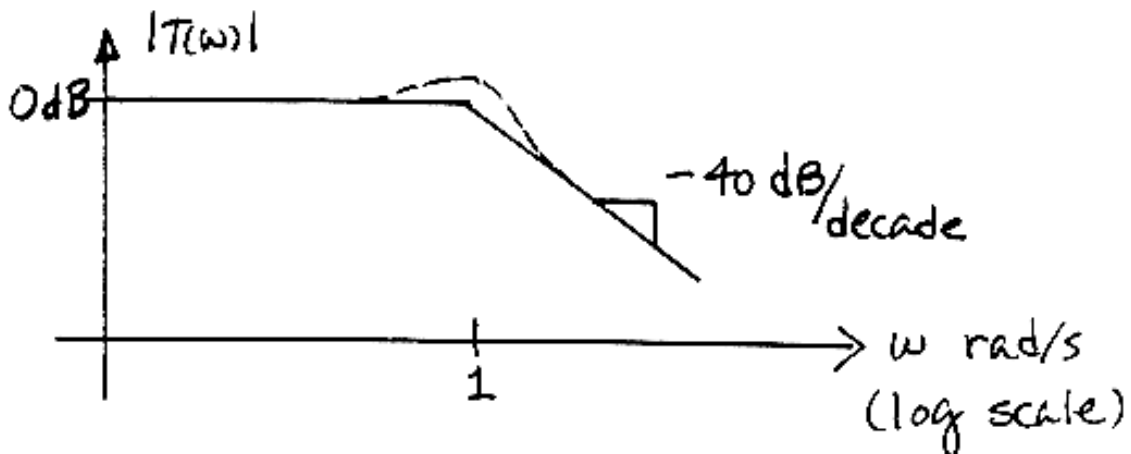

Section 13-5: Resonant Circuits

P13.5-1

$$\omega_0 = \frac{1}{\sqrt{LC}} = \frac{1}{\sqrt{\left(\frac{1}{120}\right)\left(\frac{1}{30} \times 10^{-6}\right)}} = 60 \text{ k rad/sec}$$

$$Q = R\sqrt{\frac{C}{L}} = 10,000 \sqrt{\frac{\frac{1}{30} \times 10^{-6}}{\frac{1}{120}}} = 20$$

$$\omega_1 = -\frac{\omega_0}{2Q} + \sqrt{\left(\frac{\omega_0}{2Q}\right)^2 + \omega_0^2} = 58.52 \text{ k rad/s} \quad \text{and} \quad \omega_2 = \frac{\omega_0}{2Q} + \sqrt{\left(\frac{\omega_0}{2Q}\right)^2 + \omega_0^2} = 61.52 \text{ k rad/s}$$

$$BW = \frac{1}{RC} = \frac{1}{(10000)\left(\frac{1}{30} \times 10^{-6}\right)} = 3 \text{ krad/s}$$

Notice that $BW = \omega_2 - \omega_1 = \frac{\omega_0}{Q}$.

P13.5-2

$$|\mathbf{H}(\omega)| = \frac{k}{\sqrt{1+Q^2\left(\frac{\omega}{\omega_0} - \frac{\omega_0}{\omega}\right)^2}}$$

so

$$R = k = |\mathbf{H}(\omega_0)| = \frac{8}{20 \cdot 10^{-3}} = 400 \, \Omega \quad \text{and} \quad \omega_0 = 1000 \text{ rad/s}$$

At $\omega = 897.6 \text{ rad/s}$, $|\mathbf{H}(\omega)| = \frac{4}{20 \cdot 10^{-3}} = 200$, so

$$200 = \frac{400}{\sqrt{1+Q^2\left(\frac{897.6}{1000} - \frac{1000}{897.6}\right)^2}} \Rightarrow Q = 8$$

Then

$$\left. \begin{array}{l} \frac{1}{\sqrt{LC}} = \omega_0 = 1000 \\ 400\sqrt{\frac{C}{L}} = Q = 8 \end{array} \right\} \Rightarrow \begin{array}{l} C = 20 \, \mu\text{F} \\ L = 50 \text{ mH} \end{array}$$

P13.5-3

$$\omega_0 = \frac{1}{\sqrt{LC}} = 10^5 \text{ rad/s}, \quad Q = \frac{1}{R} \sqrt{\frac{L}{C}} = 10, \quad BW = \frac{R}{L} = 10^4 \text{ rad/s}$$

P13.5-4

$$\omega_0 = \frac{1}{\sqrt{LC}} = 10^4 \text{ rad/s}, \quad Q = \frac{1}{R} \sqrt{\frac{L}{C}} = 10, \quad BW = \frac{R}{L} = 10^3 \text{ rad/s}$$

P13.5-5

$$R = \mathbf{Z}(\omega_0) = 100 \, \Omega$$

$$\frac{1}{100C} = BW = 500 \Rightarrow C = 20 \, \mu\text{F}$$

$$\frac{1}{\sqrt{(20 \cdot 10^{-6})L}} = \omega_0 = 2500 \Rightarrow L = 8 \text{ mH}$$

P13.5-6

$$R = \frac{1}{\mathbf{Y}(\omega_0)} = 100 \, \Omega$$

$$\frac{100}{L} = BW = 500 \Rightarrow L = 0.2 \text{ H}$$

$$\frac{1}{\sqrt{(0.2)C}} = \omega_0 = 2500 \Rightarrow C = 0.8 \, \mu\text{F}$$

P13.5-7

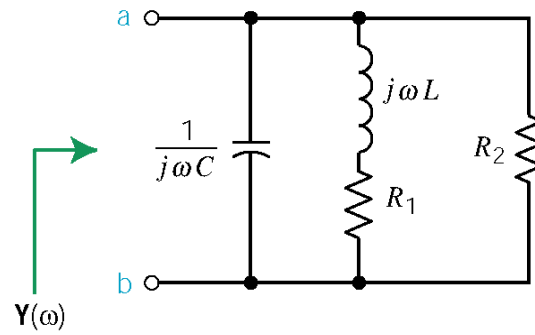

$$\begin{aligned}
 \mathbf{Y}(\omega) &= j\omega C + \frac{1}{R_1 + j\omega L} + \frac{1}{R_2} \\
 &= \frac{(R_1 + R_2 - \omega^2 C L R_2) + j\omega(L + C R_1 R_2)}{R_2(R_1 + j\omega L)} \times \frac{R_1 - j\omega L}{R_1 - j\omega L} \\
 &= \frac{R_1(R_1 + R_2 - \omega^2 C L R_2) - \omega^2 L(L + C R_1 R_2) + j\omega R_1(L C R_1 R_2) - j\omega L(R_1 + R_2 - \omega^2 C L R_2)}{R_2(R_1 - \omega^2 L^2)}
 \end{aligned}$$

$\omega = \omega_0$ is the frequency at which the imaginary part of $\mathbf{Y}(\omega)$ is zero :

$$R_1(L C R_1 R_2) - L(R_1 + R_2 - \omega_0^2 C L R_2) = 0 \Rightarrow \omega_0 = \sqrt{\frac{L R_2 - C R_1^2 R_2}{C L^2 R_2}} = 12.9 \text{ Mrad/sec}$$

P13.5-8

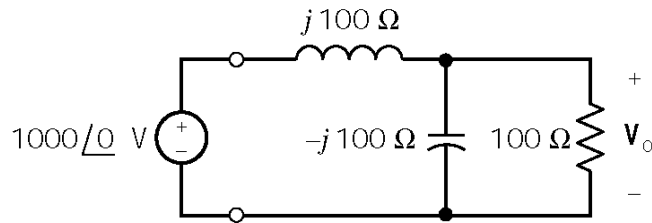

(a) Using voltage division yields

$$\begin{aligned} \mathbf{V}_o &= (1000\angle 0^\circ) \frac{(100)(-j100)}{(100)(-j100) + j100} \\ &= (1000\angle 0^\circ) \frac{100/\sqrt{2}\angle -135^\circ}{100/\sqrt{2}\angle -135^\circ + j100} = \frac{10^5}{50\sqrt{2}\angle -135^\circ} = 1000\angle 90^\circ \text{ V} \end{aligned}$$

$$\therefore |\mathbf{V}_o| = 1000 \text{ V}$$

(b) Do a source transformation to obtain

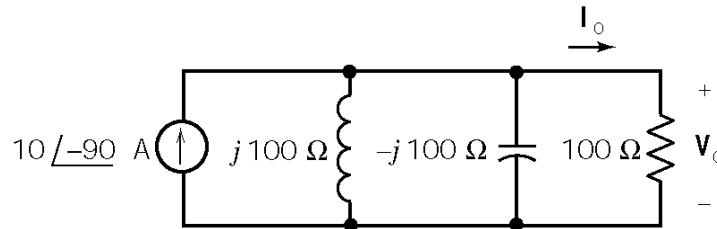

This is a resonant circuit with $\omega_0 = 1/\sqrt{LC} = 400$ rad/s. That's also the frequency of the input, so this circuit is being operated at resonance. At resonance the impedances of the capacitor and inductor cancel each other, leaving the impedance of the resistor. Increasing the resistance by a factor of 10 will increase the voltage \mathbf{V}_o by a factor of 10. This increased voltage will cause increased currents in both the inductance and the capacitance, causing the sparks and smoke.

P13.5-9

Let $G_2 = \frac{1}{R_2}$. Then

$$\begin{aligned} \mathbf{Z} &= R_1 + j\omega L + \frac{1}{G_2 + j\omega C} \\ &= \frac{(R_1 G_2 + 1 - \omega^2 LC) + j(\omega L G_2 + \omega C R_1)}{G_2 + j\omega C} \end{aligned}$$

At resonance, $\angle \mathbf{Z} = 0^\circ$ so

$$\tan^{-1} \frac{\omega L G_2 + \omega C R_1}{(R_1 G_2 + 1 - \omega^2 LC)} = \tan^{-1} \frac{\omega C}{G_2}$$

so

$$\frac{\omega L G_2 + \omega C R_1}{(R_1 G_2 + 1 - \omega^2 LC)} = \frac{\omega C}{G_2} \Rightarrow \omega^2 = \frac{C - L G_2^2}{L C^2} \quad \text{and} \quad C > G_2^2 L$$

With $R_1 = R_2 = 1 \Omega$ and $\omega_0 = 100 \text{ rad/s}$, $\omega_0^2 = 10^4 = \frac{C - L}{L C^2}$. Then choose C and calculate L :

$$C = 10 \text{ mF} \Rightarrow L = 5 \text{ mH}$$

Since $C > G_2^2 L$, we are done.

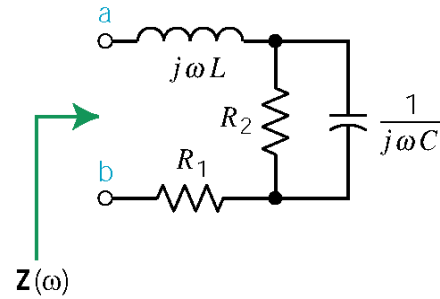

P13.5-10

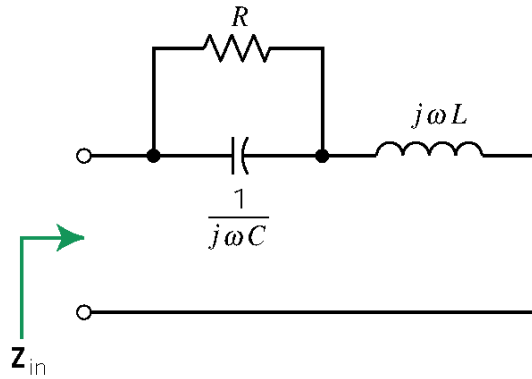

(a)

$$\mathbf{Z}_{in} = j\omega L + \frac{\frac{R}{j\omega C}}{R + \frac{1}{j\omega C}} = \frac{(R - \omega^2 RLC) + j\omega L}{1 + j\omega RC}$$

Consequently,

$$|\mathbf{Z}_{in}| = \sqrt{\frac{(R - \omega^2 RLC)^2 + (\omega L)^2}{1 + (\omega RC)^2}}$$

(b)

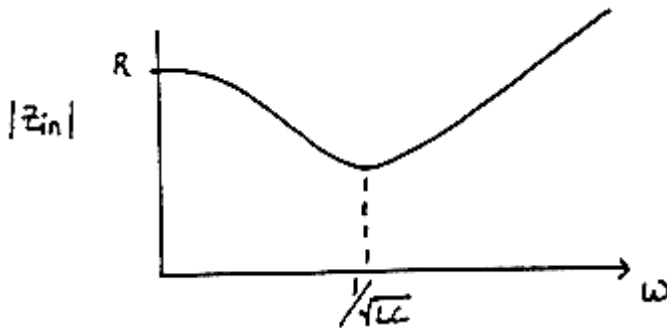

(c)

$$\omega = \frac{1}{\sqrt{LC}} \Rightarrow |\mathbf{Z}_{in}| = \frac{1}{\sqrt{\frac{C}{L} \left(1 + \frac{R^2 C}{L}\right)}}$$

P13.5-11

Let $\mathbf{V}(\omega) = A\angle 0$ and $\mathbf{V}_2(\omega) = B\angle \theta$. Then

$$\mathbf{Y}(\omega) = \frac{\mathbf{I}(\omega)}{\mathbf{V}(\omega)} = \frac{\mathbf{V}(\omega) - \mathbf{V}_2(\omega)}{R} = \frac{A - B\angle \theta}{AR} = \frac{A - B\cos\theta - jB\sin\theta}{AR}$$

$$|\mathbf{Y}(\omega)| = \frac{\sqrt{(A - B\cos\theta)^2 + (B\sin\theta)^2}}{AR}$$

PSpice Problems

SP13.1

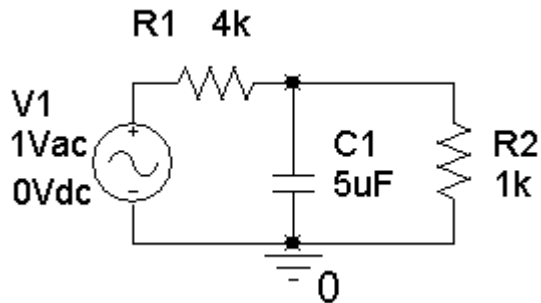

Here are the magnitude and phase frequency response plots:

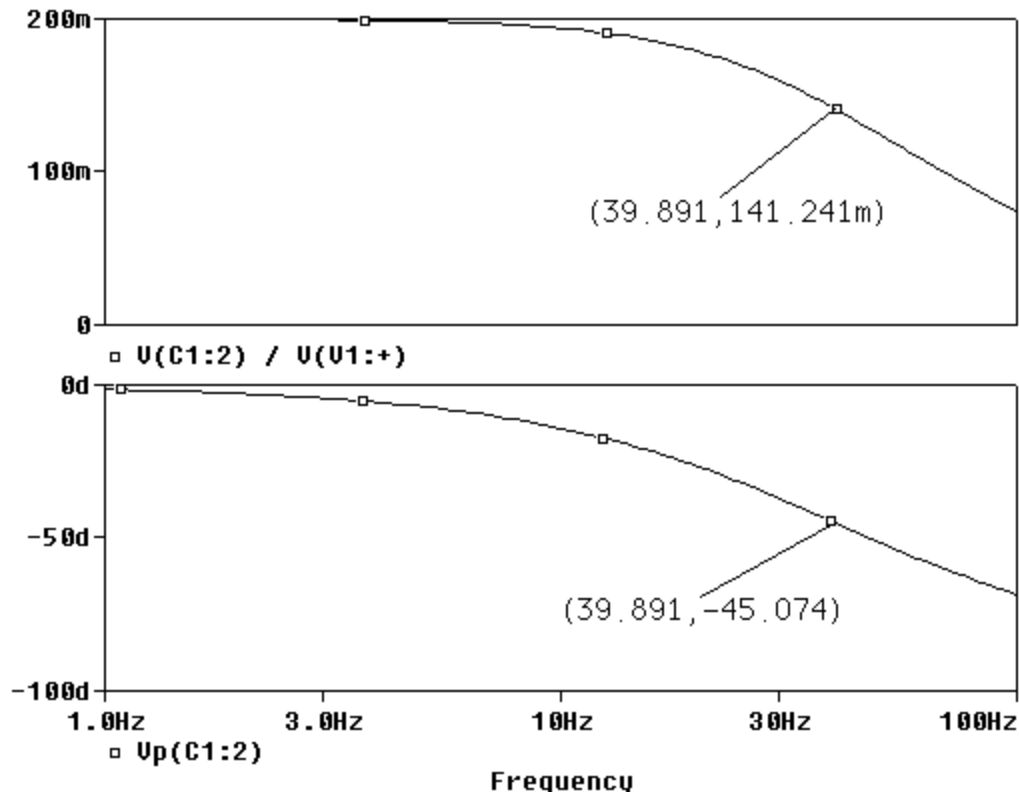

From the magnitude plot, the low frequency gain is $k = 200\text{m} = 0.2$.

From the phase plot, the angle is -45° at $p = 2\pi(39.891) = 251 \text{ rad/s}$.

SP13-2

Here is the magnitude frequency response plot:

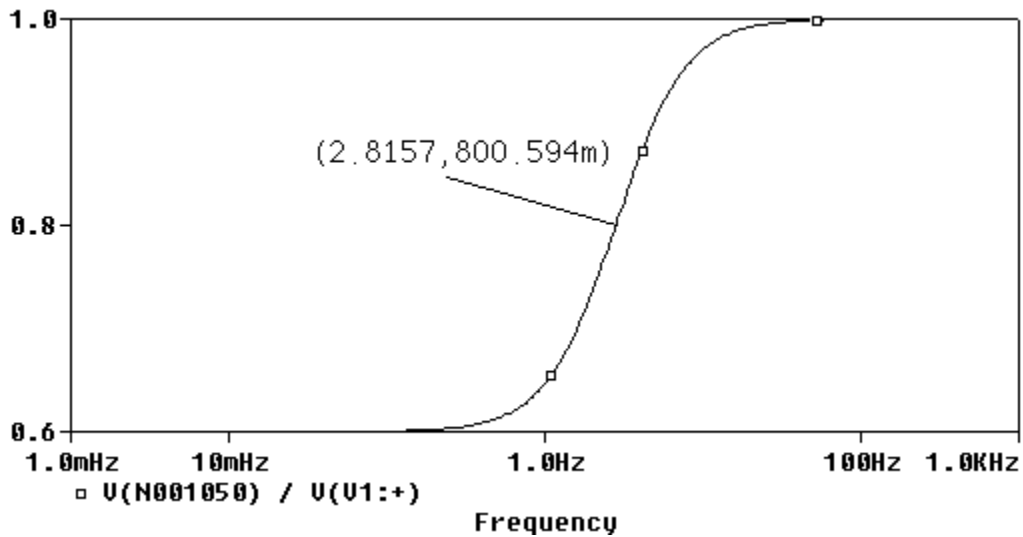

The low frequency gain is $0.6 = \lim_{\omega \rightarrow 0} \mathbf{H}(\omega) = k \Rightarrow k = 0.6$.

The high frequency gain is $1 = \lim_{\omega \rightarrow \infty} \mathbf{H}(\omega) = k \frac{p}{z} \Rightarrow z = (0.6) p$

At $\omega = 2\pi(2.8157) = 17.69$ rad/s,

$$0.8 = 0.6 \frac{\sqrt{1 + \left(\frac{17.69}{0.6p}\right)^2}}{\sqrt{1 + \left(\frac{17.69}{p}\right)^2}} \Rightarrow \frac{16}{9} = \frac{p^2 + 869}{p^2 + 313}$$

$$\Rightarrow \frac{16}{9}(p^2 + 313) = p^2 + 869$$

$$\Rightarrow (0.77778)p^2 = 312.56$$

$$\Rightarrow p = 20 \text{ rad/s}$$

$$\Rightarrow z = 12 \text{ rad/s}$$

SP13-3

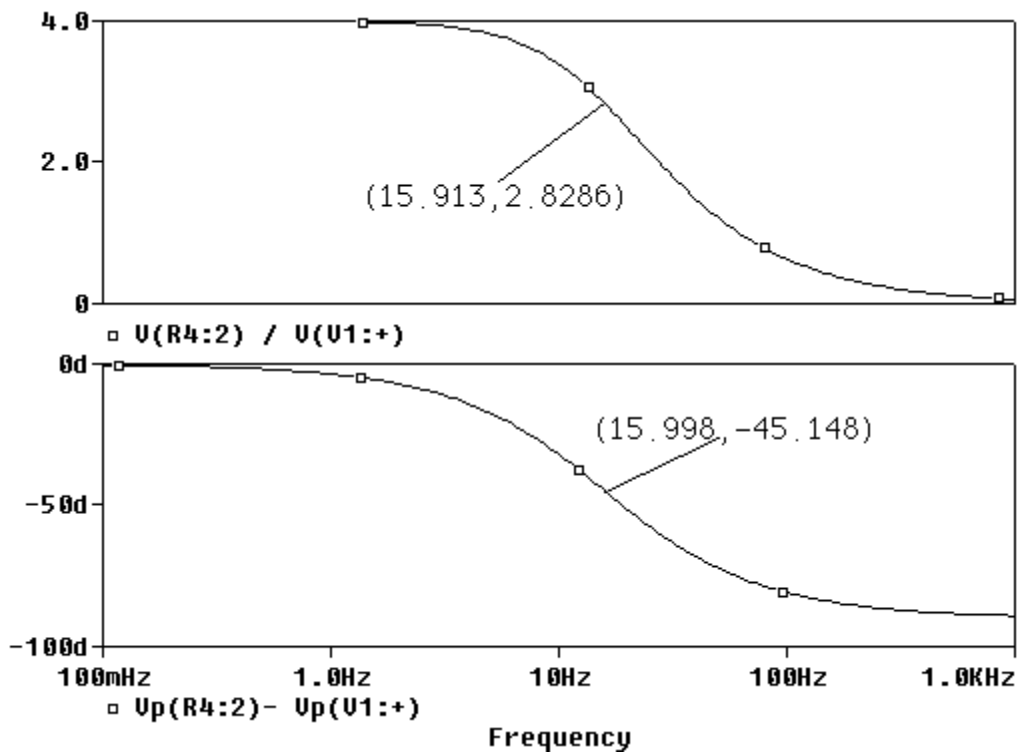
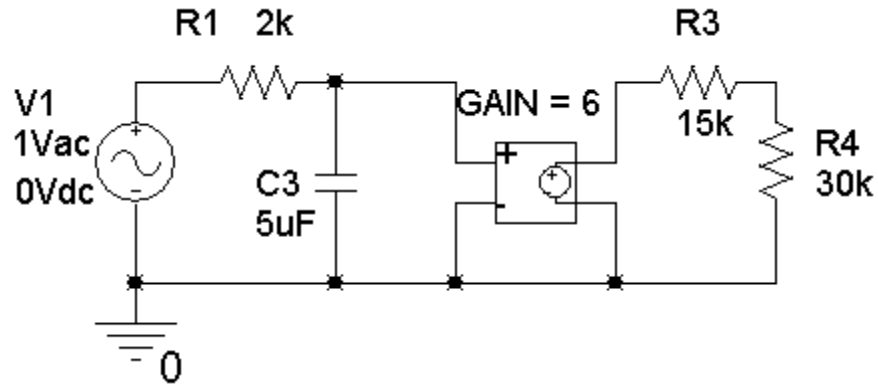

From the magnitude plot, the low frequency gain is $k = 4.0$.

From the phase plot, the angle is -45° at $p = 2\pi(15.998) = 100.5 \text{ rad/s}$.

SP13-4

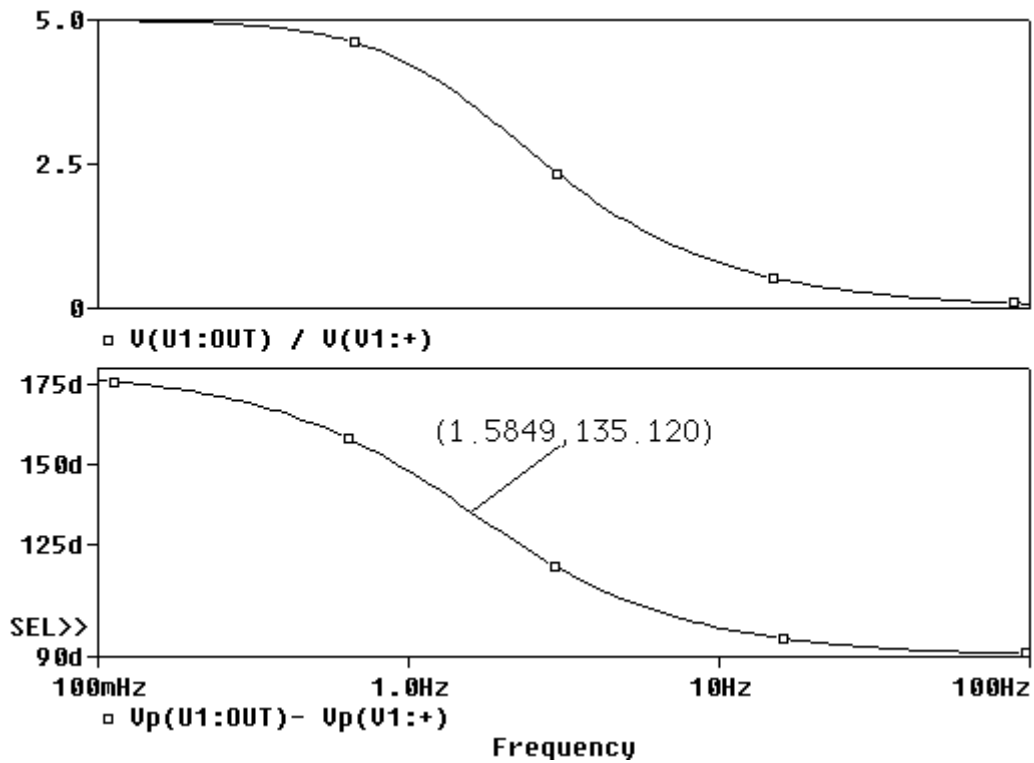
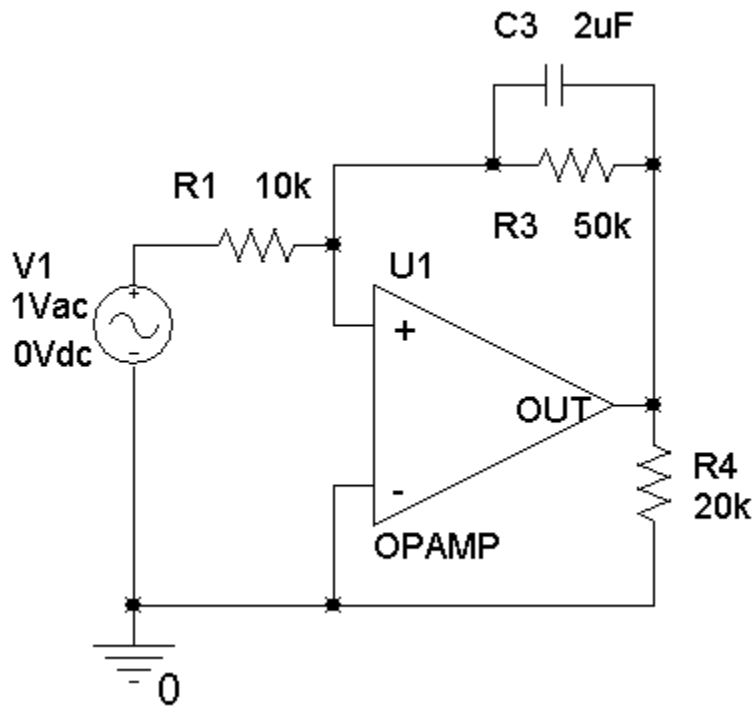

From the magnitude plot, the low frequency gain is $k = 5.0$.

From the phase plot, the angle is $180^\circ - 45^\circ = 135^\circ$ at $p = 2\pi(1.5849) = 9.958 \text{ rad/s}$.

SP13-5

$$\mathbf{H}(\omega) = -\frac{\frac{10^4}{R}}{1 + j\omega C 10^4} = \frac{\frac{10^4}{R}}{\sqrt{1 + (\omega C 10^4)^2}} \angle -\tan^{-1}(\omega C 10^4)$$

When $\omega = 200$ rad/sec = 31.83 Hertz

$$1.8565 \angle 158^\circ = \frac{\frac{10^4}{R}}{\sqrt{1 + (\omega C 10^4)^2}} \angle -\tan^{-1}(\omega C 10^4)$$

Equating phase shifts gives

$$\omega C 10^4 = 10^3 \frac{C R 10^4}{R + 10^4} = \tan(22^\circ) = 0.404 \Rightarrow C = 0.2 \mu\text{F}$$

Equating gains gives

$$1.8565 = \frac{\frac{10^4}{R}}{\sqrt{1 + (\omega C 10^4)^2}} = \frac{\frac{10^4}{R}}{\sqrt{1 + (0.404)^2}} \Rightarrow R = 5 \text{ k}\Omega$$

SP13-6

$$\mathbf{H}(\omega) = \frac{\frac{10^4}{1 + j\omega C R_2}}{\frac{10^4}{1 + j\omega C 10^4} + R} = \frac{\frac{10^4}{R + 10^4}}{1 + j\omega \frac{C R 10^4}{R + 10^4}} = \frac{\frac{10^4}{R + 10^4}}{\sqrt{1 + \left(\omega \frac{C R 10^4}{R + 10^4}\right)^2}} \angle -\tan^{-1}\left(\omega \frac{C R 10^4}{R + 10^4}\right)$$

When $\omega = 1000$ rad/sec = 159.1 Hertz

$$0.171408 \angle -59^\circ = \frac{\frac{10^4}{R + 10^4}}{\sqrt{1 + \left(\omega \frac{C R 10^4}{R + 10^4}\right)^2}} \angle -\tan^{-1}\left(\omega \frac{C R 10^4}{R + 10^4}\right)$$

Equating phase shifts gives

$$\omega \frac{C R 10^4}{R + 10^4} = 10^3 \frac{C R 10^4}{R + 10^4} = \tan(59^\circ) = 1.665$$

Equating gains gives

$$0.171408 = \frac{\frac{10^4}{R+10^4}}{\sqrt{1 + \left(\omega \frac{C R 10^4}{R+10^4} \right)^2}} = \frac{\frac{10^4}{R+10^4}}{\sqrt{1 + (1.665)^2}} \Rightarrow R = 20 \text{ k}\Omega$$

Substitute this value of R into the equation for phase shift to get:

$$1.665 = 10^3 \frac{C R 10^4}{R+10^4} = 10^3 \frac{C (20 \times 10^3) 10^4}{(20 \times 10^3) + 10^4} \Rightarrow C = 0.25 \text{ }\mu\text{F}$$

Verification Problems

VP13-1

When $\omega < 6300$ rad/s, $\mathbf{H}(\omega) \cong 0.1$, which agrees with the tabulated values of $|\mathbf{H}(\omega)|$ corresponding to $\omega = 200$ and 400 rad/s.

When $\omega > 6300$ rad/s, $\mathbf{H}(\omega) \cong 0.1$, which agrees with the tabulated values of $|\mathbf{H}(\omega)|$ corresponding to $\omega = 12600$, 25000 , 50000 and 100000 rad/s.

At $\omega = 6300$ rad/s, we expect $|\mathbf{H}(\omega)| = -3 \text{ dB} = 0.707$. This agrees with the tabulated value of $|\mathbf{H}(\omega)|$ corresponding to $\omega = 6310$ rad/s.

At $\omega = 630$ rad/s, we expect $|\mathbf{H}(\omega)| = -20 \text{ dB} = 0.14$. This agrees with the tabulated values of $|\mathbf{H}(\omega)|$ corresponding to $\omega = 400$ and 795 rad/s.

This data does seem reasonable.

VP13-2

$$BW = \frac{\omega_0}{Q} = \frac{10,000}{70} = 143 \neq 71.4 \text{ rad/s}. \text{ Consequently, this report is not correct.}$$

VP13-3

$$\omega_0 = \frac{1}{\sqrt{LC}} = 10 \text{ k rad/s} = 1.59 \text{ kHz}, \quad Q = \frac{1}{R} \sqrt{\frac{L}{C}} = 20 \quad \text{and} \quad BW = \frac{R}{L} = 500 \text{ rad/s} = 79.6 \text{ Hz}$$

The reported results are correct.

VP13-4

The network function indicates a zero at 200 rad/s and a pole at 800 rad/s. In contrast, the Bode plot indicates a pole at 200 rad/s and a zero at 800 rad/s. Consequently, the Bode plot and network function don't correspond to each other.

Design Problems

DP13-1

Pick the appropriate circuit from Table 13.4-2.

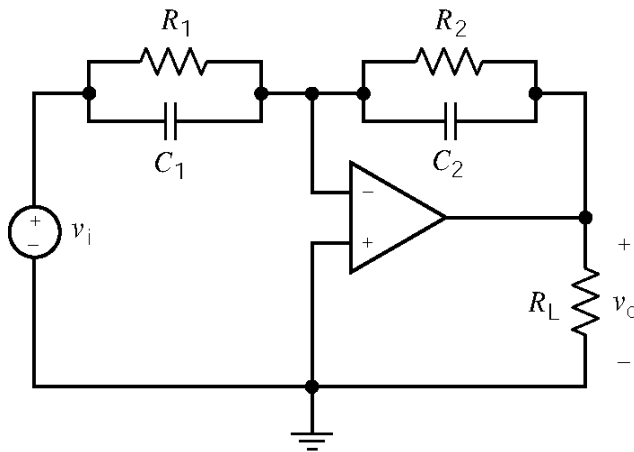

$$\mathbf{H}(\omega) = -k \frac{1 + j \frac{\omega}{z}}{1 + j \frac{\omega}{p}}$$

where

$$k = \frac{R_2}{R_1}$$

$$z = \frac{1}{C_1 R_1}$$

$$p = \frac{1}{C_2 R_2}$$

We require

$$2\pi \times 1000 < z = \frac{1}{C_1 R_1}, \quad 2\pi \times 10000 > p = \frac{1}{C_2 R_2}, \quad 2 = k = \frac{R_2}{R_1} \quad \text{and} \quad 5 = k \frac{p}{z} = \frac{C_1}{C_2}$$

Try $z = 2\pi \times 2000$. Pick $C_1 = 0.05 \mu\text{F}$. Then

$$R_1 = \frac{1}{C_1 z} = 1.592 \text{ k}\Omega, \quad R_2 = 2 R_1 = 3.183 \text{ k}\Omega \quad \text{and} \quad C_2 = \frac{C_1}{k \frac{p}{z}} = \frac{C_1}{2} = 0.01 \mu\text{F}$$

Check: $p = \frac{1}{C_2 R_2} = 31.42 \text{ k rad/s} < 2\pi \cdot 10,000 \text{ rad/s}$.

DP13-2

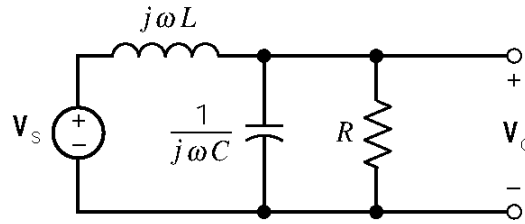

$$\mathbf{H}(\omega) = \frac{V_o(\omega)}{V_s(\omega)} = \frac{\frac{1}{j\omega C} \parallel R}{j\omega L + \left(\frac{1}{j\omega C} \parallel R\right)} = \frac{\frac{R}{1+j\omega CR}}{j\omega L + \frac{R}{1+j\omega CR}} = \frac{\frac{1}{LC}}{-\omega^2 + j\omega \frac{1}{RC} + \frac{1}{LC}}$$

Pick $\frac{1}{\sqrt{LC}} = \omega_0 = 2\pi(100 \cdot 10^3)$ rad/s. When $\omega = \omega_0$

$$\mathbf{H}_0(\omega) = \frac{\frac{1}{LC}}{-\frac{1}{LC} + j \frac{1}{\sqrt{LC}} \frac{1}{RC} + \frac{1}{LC}}$$

So $|\mathbf{H}(\omega_0)| = R\sqrt{\frac{C}{L}}$. We require

$$-3 \text{ dB} = 0.707 = |\mathbf{H}(\omega_0)| = R\sqrt{\frac{C}{L}} = 1000\sqrt{\frac{C}{L}}$$

Finally

$$\left. \begin{array}{l} \frac{1}{\sqrt{LC}} = 2\pi(100 \cdot 10^3) \\ 0.707 = 1000\sqrt{\frac{C}{L}} \end{array} \right\} \Rightarrow \begin{array}{l} C = 1.13 \text{ nF} \\ L = 2.26 \text{ mH} \end{array}$$

DP13-3

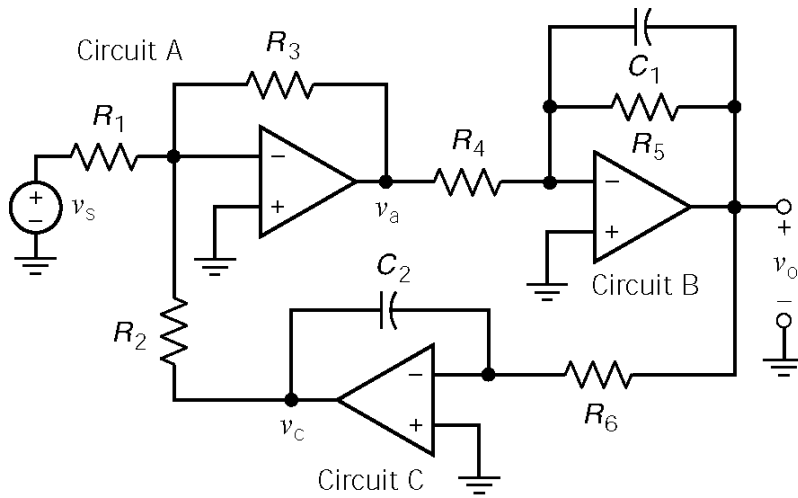

- $R_1 = 10 \text{ k}\Omega$
- $R_2 = 866 \text{ k}\Omega$
- $R_3 = 8.06 \text{ k}\Omega$
- $R_4 = 1 \text{ M}\Omega$
- $R_5 = 2.37 \text{ M}\Omega$
- $R_6 = 499 \text{ k}\Omega$
- $C_1 = 0.47 \text{ }\mu\text{F}$
- $C_2 = 0.1 \text{ }\mu\text{F}$

$$\text{Circuit A} \quad \mathbf{V}_a = -\frac{R_3}{R_2} \mathbf{V}_c - \frac{R_3}{R_1} \mathbf{V}_s = -\mathbf{H}_1 \mathbf{V}_c - \mathbf{H}_2 \mathbf{V}_s$$

$$\text{Circuit B} \quad \mathbf{V}_o = -\frac{\frac{R_5}{R_4}}{1 + j\omega C_1 R_5} \mathbf{V}_a = -\mathbf{H}_3 \mathbf{V}_a$$

$$\text{Circuit C} \quad \mathbf{V}_c = -\frac{1}{j\omega C_2 R_6} \mathbf{V}_o = -\mathbf{H}_4 \mathbf{V}_o$$

Then

$$\begin{aligned} \mathbf{V}_c &= \mathbf{H}_3 \mathbf{H}_4 \mathbf{V}_a \\ \mathbf{V}_a &= -\mathbf{H}_2 \mathbf{V}_s - \mathbf{H}_1 \mathbf{H}_3 \mathbf{H}_4 \mathbf{V}_a \Rightarrow \mathbf{V}_a = \frac{-\mathbf{H}_2}{1 + \mathbf{H}_1 \mathbf{H}_3 \mathbf{H}_4} \mathbf{V}_s \\ \mathbf{V}_o &= -\mathbf{H}_3 \mathbf{V}_a = \frac{\mathbf{H}_2 \mathbf{H}_3}{1 + \mathbf{H}_1 \mathbf{H}_3 \mathbf{H}_4} \mathbf{V}_s \end{aligned}$$

After some algebra

$$\mathbf{V}_o = \frac{j\omega \frac{R_3}{R_1 R_4 C_1}}{\frac{R_3}{R_2 R_4 R_6 C_1 C_2} - \omega^2 + j \frac{\omega}{R_5 C_1}} \mathbf{V}_s$$

This MATLAB program plots the Bode plot:

```
R1=10;           % units: kOhms and mF so RC has units of sec
R2=866;
R3=8.060;
R4=1000;
```

```

R5=2370;
R6=449;
C1=0.00047;
C2=0.0001;

pi=3.14159;
fmin=5*10^5;
fmax=2*10^6;
f=logspace(log10(fmin),log10(fmax),200);
w=2*pi*f;

b1=R3/R1/R4/C1;
a0=R3/R2/R4/R6/C1/C2;
a1=R5/C1;

for k=1:length(w)
    H(k)=(j*w(k)*b1)/(a0-w(k)*w(k)+j+w(k)*a1);
    gain(k)=abs(H(k));
    phase(k)=angle(H(k));
end

subplot(2,1,1), semilogx(f, 20*log10(gain))
xlabel('Frequency, Hz'), ylabel('Gain, dB')
title('Bode Plot')
subplot(2,1,2), semilogx(f, phase*180/pi)
xlabel('Frequency, Hz'), ylabel('Phase, deg')

```

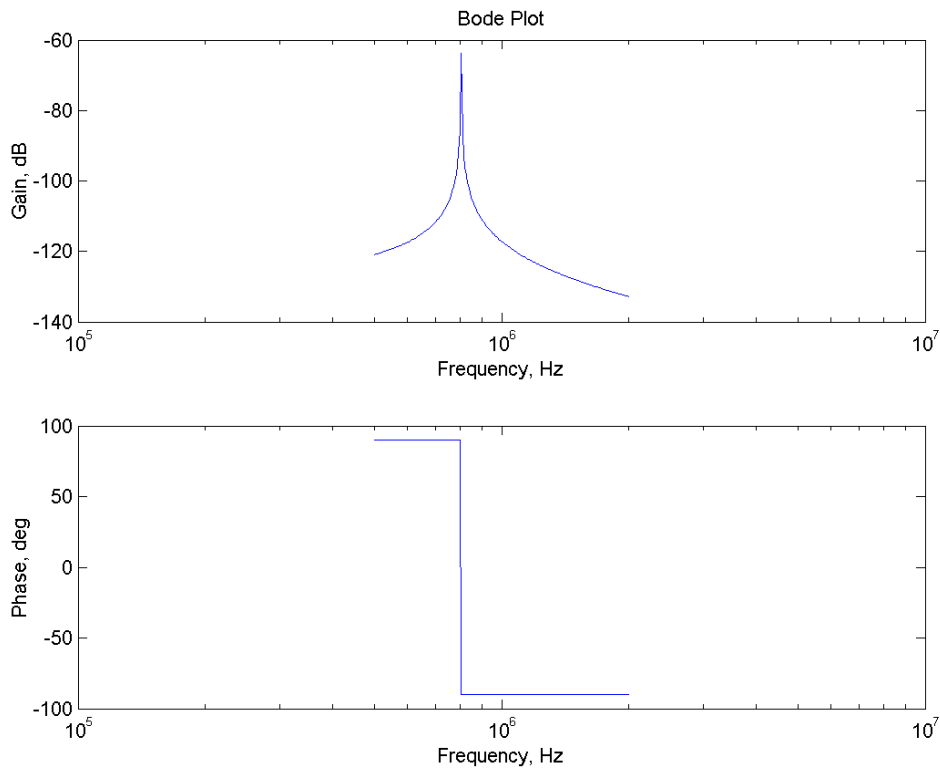

DP13-4

Pick the appropriate circuits from Table 13.4-2.

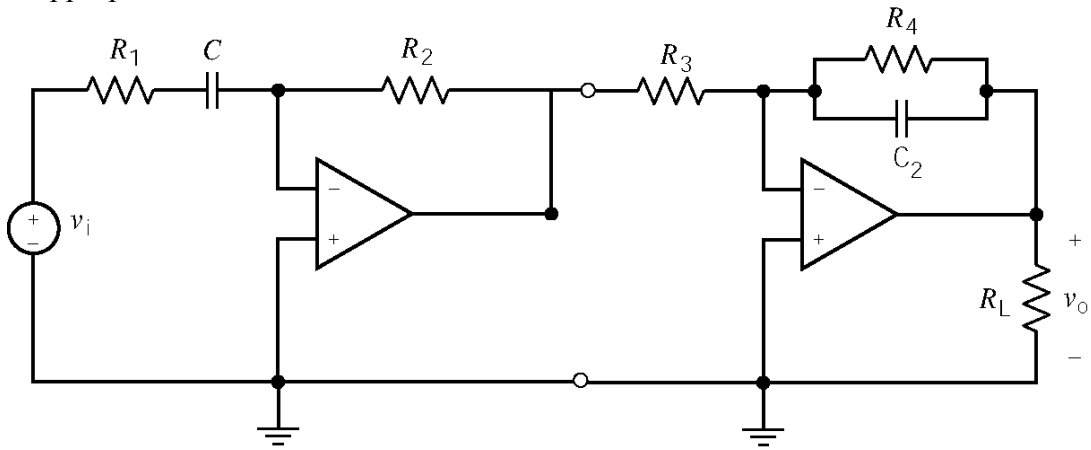

$$H_1(\omega) = -k_1 \frac{j\omega}{1 + j\frac{\omega}{p_1}}$$

where

$$k_1 = R_2 C$$

$$p_1 = \frac{1}{CR_1}$$

$$H_2(\omega) = -\frac{k_2}{1 + j\frac{\omega}{p_2}}$$

where

$$k_2 = \frac{R_2}{R_1}$$

$$p_2 = \frac{1}{CR_2}$$

We require

$$10 = -k_1 k_2 = R_2 C_1 \frac{R_4}{R_3}, \quad 200 = p_1 = \frac{1}{R_1 C_1} \quad \text{and} \quad 500 = p_2 = \frac{1}{C_2 R_4}$$

Pick $C_1 = 1 \mu\text{F}$. Then $R_1 = \frac{1}{p_1 C_1} = 5 \text{ k}\Omega$. Pick $C_2 = 0.1 \mu\text{F}$. Then $R_4 = \frac{1}{p_2 C_2} = 20 \text{ k}\Omega$.

Next

$$10 = \frac{R_2}{R_3} (10^{-6})(20 \cdot 10^3) \Rightarrow \frac{R_2}{R_3} = 500$$

Let $R_2 = 500 \text{ k}\Omega$ and $R_3 = 1 \text{ k}\Omega$.

DP13-5

Pick the appropriate circuits from Table 13.4-2.

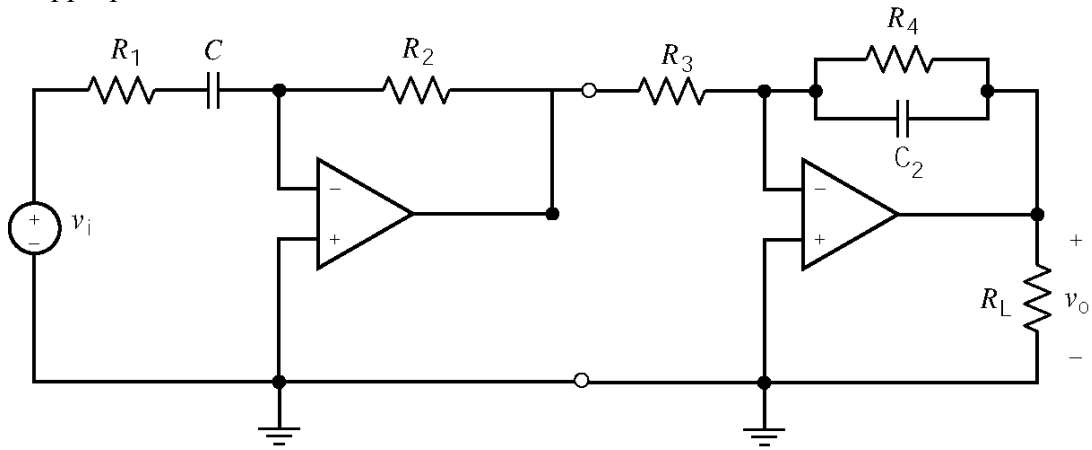

$$H_1(\omega) = -k_1 \frac{j\omega}{1 + j\frac{\omega}{p_1}}$$

where

$$k_1 = R_2 C$$

$$p_1 = \frac{1}{CR_1}$$

$$H_2(\omega) = \frac{k_2}{1 + j\frac{\omega}{p_2}}$$

where

$$k_2 = \frac{R_2}{R_1}$$

$$p_2 = \frac{1}{CR_2}$$

We require

$$20 \text{ dB} = 10 = -k_1 k_2 = R_2 C_1 \frac{R_4}{R_3}, \quad 0.1 = p_1 = \frac{1}{R_1 C_1} \quad \text{and} \quad 100 = p_2 = \frac{1}{C_2 R_4}$$

Pick $C_1 = 20 \mu\text{F}$. Then $R_1 = \frac{1}{p_1 C_1} = 500 \text{ k}\Omega$. Pick $C_2 = 1 \mu\text{F}$. Then $R_4 = \frac{1}{p_2 C_2} = 10 \text{ k}\Omega$.

Next

$$10 = \frac{R_2}{R_3} (20 \cdot 10^{-6})(10 \cdot 10^3) \Rightarrow \frac{R_2}{R_3} = 50$$

Let $R_2 = 200 \text{ k}\Omega$ and $R_3 = 4 \text{ k}\Omega$.

DP13-6

The network function of this circuit is $\mathbf{H}(\omega) = \frac{1 + \frac{R_2}{R_3}}{1 + j\omega R_1 C}$

The phase shift of this network function is $\theta = -\tan^{-1} \omega R_1 C$

The gain of this network function is $G = |\mathbf{H}(\omega)| = \frac{1 + \frac{R_3}{R_2}}{\sqrt{1 + (\omega R_1 C)^2}} = \frac{1 + \frac{R_3}{R_2}}{\sqrt{1 + (\tan \theta)^2}}$

Design of this circuit proceeds as follows. Since the frequency and capacitance are known, R_1 is calculated from $R_1 = \frac{\tan(-\theta)}{\omega C}$. Next pick $R_2 = 10 \text{ k}\Omega$ (a convenient value) and calculate R_3 using

$$R_3 = (G \cdot \sqrt{1 + (\tan \theta)^2} - 1) \cdot R_2. \text{ Finally}$$

$$\theta = -45 \text{ deg}, G = 2, \omega = 1000 \text{ rad/s} \Rightarrow R_1 = 10 \text{ k}\Omega, R_2 = 10 \text{ k}\Omega, R_3 = 18.284 \text{ k}\Omega, C = 0.1 \mu\text{F}$$

DP13-7

From Table 13.4-2 and the Bode plot:

$$800 = z = \frac{1}{R_1(0.5 \times 10^{-6})} \Rightarrow R_1 = 2.5 \text{ k}\Omega$$

$$32 \text{ dB} = 40 = \frac{R_2}{R_1} \Rightarrow R_2 = 100 \text{ k}\Omega$$

$$200 = p = \frac{1}{R_2 C} \Rightarrow C = \frac{1}{(200)(100 \times 10^3)} = 0.05 \mu\text{F}$$

$$(\text{Check: } 20 \text{ dB} = 10 = k \frac{p}{z} = \frac{0.5 \times 10^{-6}}{C} = \frac{0.5 \times 10^{-6}}{0.05 \times 10^{-6}})$$

DP13-8

$$\mathbf{H}(\omega) = \frac{-R_2}{1 + \frac{1}{j\omega C}} = -\frac{j\omega C R_2}{1 + j\omega C R_1}$$

$$195^\circ = 180 + 90 - \tan^{-1} \omega C R_1 \Rightarrow R_1 = \frac{\tan(270^\circ - 195^\circ)}{(1000)(0.1 \times 10^{-6})} = 37.3 \text{ k}\Omega$$

$$10 = \lim_{\omega \rightarrow \infty} |\mathbf{H}(\omega)| = \frac{R_2}{R_1} \Rightarrow R_2 = 10R_1 = 373 \text{ k}\Omega$$

Chapter 14: The Laplace Transform

Exercises

Ex. 14.3-1

$$f(t) = \cos \omega t = \frac{e^{+j\omega t} + e^{-j\omega t}}{2} \quad \text{and} \quad \mathcal{L}[e^{at}] = \frac{1}{s-a}$$

$$F(s) = \mathcal{L}[\cos \omega t] = \frac{1}{2} \left[\frac{1}{s-j\omega} + \frac{1}{s+j\omega} \right] = \frac{s}{s^2 + \omega^2}$$

Ex. 14.3-2

$$F(s) = \mathcal{L}[e^{-2t} + \sin t] = \mathcal{L}[e^{-2t}] + \mathcal{L}[\sin t] = \frac{1}{s+2} + \frac{1}{s^2+1} = \frac{s^2 + s + 3}{(s+2)(s^2+1)}$$

Ex. 14.4-1

$$F(s) = \mathcal{L}[2u(t) + 3e^{-4t}u(t)] = 2\mathcal{L}[u(t)] + 3\mathcal{L}[e^{-4t}u(t)] = \frac{2}{s} + \frac{3}{s+4}$$

Ex. 14.4-2

$$F(s) = \mathcal{L}[\sin(t-2)u(t-2)] = e^{-2s} \mathcal{L}[\sin t] = e^{-2s} \left(\frac{1}{s^2+1} \right)$$

Ex. 14.4-3

$$F(s) = \mathcal{L}[t e^{-t}] = \mathcal{L}[t]_{s \rightarrow s+1} = \frac{1}{s^2} \Big|_{s \rightarrow s+1} = \frac{1}{(s+1)^2}$$

Ex. 14.4-4

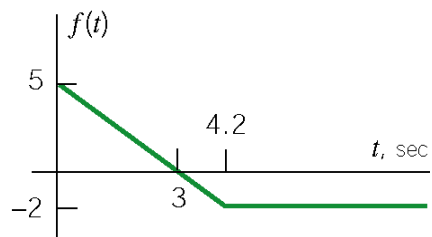

$$f(t) = \left(-\frac{5}{3}t + 5 \right) u(t) - \left(-\frac{5}{3}(t-4.2) \right) u(t-4.2)$$

$$F(s) = \left(-\frac{5}{3s^2} + \frac{5}{s} \right) - e^{-4.2s} \left(-\frac{5}{3s^2} \right) = \frac{15s + 5(e^{-4.2s} - 1)}{3s^2}$$

Ex. 14.4-5

$$F(s) = \int_0^{\infty} f(t) e^{-st} dt = \int_0^2 3e^{-st} dt = \frac{3e^{-st}}{-s} \Big|_0^2 = \frac{3(1-e^{-2s})}{s}$$

Ex. 14.4-6

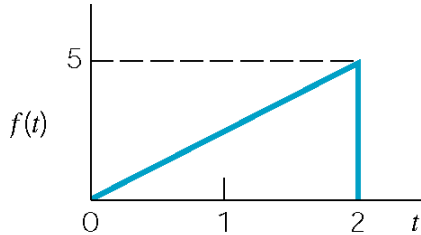

$$f(t) = \begin{cases} 5/2 t & 0 < t < 2 \\ 0 & \text{otherwise} \end{cases}$$

$$f(t) = \frac{5}{2} t [u(t) - u(t-2)] = \frac{5}{2} t u(t) - \frac{5}{2} t u(t-2) = \frac{5}{2} [t u(t) - (t-2)u(t-2) - 2u(t-2)]$$

$$\therefore F(s) = \mathcal{L}[f(t)] = \frac{5}{2} \left[\frac{1}{s^2} - \frac{e^{-2s}}{s^2} - \frac{2e^{-2s}}{s} \right] = \frac{5}{2} \frac{1}{s^2} [1 - e^{-2s} - 2s e^{-2s}]$$

Ex. 14.5-1

$$F(s) = \frac{c+jd}{s+a-j\omega} + \frac{c-jd}{s+a+j\omega} = \frac{me^{j\theta}}{s+a-j\omega} + \frac{me^{j\theta}}{s+a+j\omega} \quad \text{where } m = \sqrt{c^2+d^2}, \quad \theta = \tan^{-1} d/c$$

$$\therefore f(t) = e^{-at} [c \cos \omega t - d \sin \omega t] u(t) = e^{-at} [\sqrt{c^2+d^2} \cos(\omega t + \theta)] u(t) = m e^{-at} \cos(\omega t + \theta) u(t)$$

Ex. 14.5-2

(a)
$$F(s) = \frac{8s-3}{s^2+4s+13} = \frac{1}{2} \times \frac{2(8s-3)}{(s+2)^2+9}$$

$$\therefore a=2, c=8, \omega=3 \text{ \& } ca-\omega d=-3 \Rightarrow d = \frac{-3(8)(2)}{-3} = 6.33$$

$$\therefore \theta = \tan^{-1} \left(\frac{6.33}{8} \right) = 38.4^\circ, m = \sqrt{(8)^2 + (6.33)^2} = 10.2$$

$$\Rightarrow \underline{f(t) = 10.2 e^{-2t} \cos(3t + 38.40) u(t)}$$

(b) Given $F(s) = \frac{3e^{-s}}{s^2+2s+17}$, first consider $F_1(s) = \frac{3}{s^2+2s+17} = \frac{1}{2} \times \frac{(2(3))}{(s+1)^2+16}$.

Identify $a=1, c=0, \omega=4$ and $-\omega d=3 \Rightarrow d=-3/4$. Then $m=|d|=3/4, \theta=\tan^{-1}(-3/(4/0))=-90^\circ$

So $f_1(t) = (3/4)e^{-t} \sin 4t u(t)$. Next, $F(s) = e^{-s} F_1(s) \Rightarrow f(t) = f_1(t-1)$. Finally

$$\therefore f(t) = (3/4)e^{-(t-1)} \sin[4(t-1)] u(t-1)$$

Ex. 14.5-3

(a)
$$F(s) = \frac{s^2-5}{s(s+1)^2} = \frac{A}{s} + \frac{B}{s+1} + \frac{C}{(s+1)^2}$$

where

$$A = sF(s)|_{s=0} = \frac{-5}{1} = -5 \text{ and } C = (s+1)^2 F(s)|_{s=-1} = \frac{1-5}{-1} = 4$$

Multiply both sides by $s(s+1)^2$

$$s^2 - 5 = -5(s+1)^2 + Bs(s+1) + 4s \Rightarrow B = 6$$

Then

$$F(s) = \frac{-5}{s} + \frac{6}{s+1} + \frac{4}{(s+1)^2}$$

Finally

$$f(t) = (-5 + 6e^{-t} + 4te^{-t})u(t)$$

(b)
$$F(s) = \frac{4s^2}{(s+3)^3} = \frac{A}{s+3} + \frac{B}{(s+3)^2} + \frac{C}{(s+3)^3}$$

Where

$$A = \frac{1}{2} \frac{d^2}{ds^2} [(s+3)^2 F(s)]_{s=-3} = 4, \quad B = \frac{d}{ds} [(s+3)^3 F(s)]_{s=-3} = -24$$

and

$$C = (s+3)^3 F(s)_{s=-3} = 36$$

Then

$$F(s) = \frac{4}{s+3} + \frac{-24}{(s+3)^2} + \frac{36}{(s+3)^3}$$

Finally

$$f(t) = (4 - 24t + 18t^2)e^{-3t} u(t)$$

Ex. 14.6-1

$$(a) F(s) = \frac{6s+5}{s^2+2s+1} \quad f(0) = \lim_{s \rightarrow \infty} sF(s) = \lim_{s \rightarrow \infty} \left[\frac{s(6s+5)}{s^2+2s+1} \right] = 6$$

$$f(\infty) = \lim_{s \rightarrow 0} sF(s) = \lim_{s \rightarrow 0} \left[\frac{s(6s+5)}{s^2+2s+1} \right] = 0$$

$$(b) F(s) = \frac{6}{s^2-2s+1} \quad f(0) = \lim_{s \rightarrow \infty} \left[\frac{6s}{s^2-2s+1} \right] = 0$$

$$f(\infty) = \lim_{s \rightarrow 0} \left[\frac{6s}{s^2-2s+1} \right] = \text{undefined} \Rightarrow \text{no final value}$$

Ex. 14.7-1

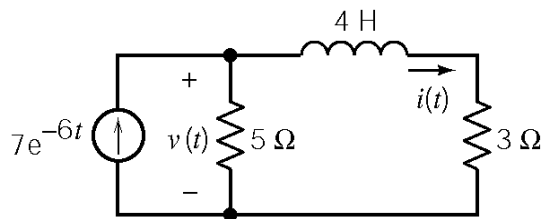

$$\text{KCL: } \frac{v_1}{5} + i = 7e^{-6t}$$

$$\text{KVL: } 4 \frac{di}{dt} + 3i - v_1 = 0 \Rightarrow v_1 = 4 \frac{di}{dt} + 3i$$

$$\text{Then } \frac{4 \frac{di}{dt} + 3i}{5} + i = 7e^{-6t} \Rightarrow \frac{di}{dt} + 2i = \frac{35}{4} e^{-6t}$$

Taking the Laplace transform of the differential equation:

$$sI(s) - i(0) + 2I(s) = \frac{35}{4} \frac{1}{s+6} \Rightarrow I(s) = \frac{35}{4} \frac{1}{(s+2)(s+6)}$$

Where we have used $i(0) = 0$. Next, we perform partial fraction expansion.

$$\frac{1}{(s+2)(s+6)} = \frac{A}{s+2} + \frac{B}{s+6} \quad \text{where } A = \left. \frac{1}{s+6} \right|_{s=-2} = \frac{1}{4} \quad \text{and } B = \left. \frac{1}{s+2} \right|_{s=-6} = -\frac{1}{4}$$

Then

$$I(s) = \frac{35}{16} \frac{1}{s+2} - \frac{35}{16} \frac{1}{s+6} \Rightarrow i(t) = \frac{35}{16} e^{-2t} - \frac{35}{16} e^{-6t}$$

Ex. 14.7-2

Apply KCL at node a to get

$$\frac{1}{48} \frac{dv_1}{dt} = \frac{v_2 - v_1}{24} \Rightarrow 2v_1 + \frac{dv_1}{dt} = 2v_2$$

Apply KCL at node b to get

$$\frac{v_2 - 50 \cos 2t}{20} + \frac{v_2 - v_1}{24} + \frac{v_2}{30} + \frac{1}{24} \frac{dv_2}{dt} = 0 \Rightarrow -v_1 + 3v_2 + \frac{dv_2}{dt} = 60 \cos 2t$$

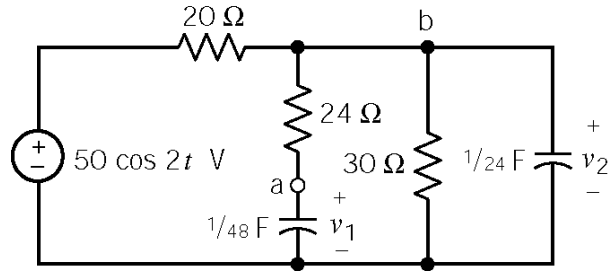

Take the Laplace transforms of these equations, using $v_1(0) = 10$ V and $v_2(0) = 25$ V, to get

$$(2+s)V_1(s) - 2V_2(s) = 10 \quad \text{and} \quad -V_1(s) + (3+s)V_2(s) = \frac{25s^2 + 60s + 100}{s^2 + 4}$$

Solve these equations using Cramer's rule to get

$$\begin{aligned} V_2(s) &= \frac{(2+s) \left(\frac{25s^2 + 60s + 100}{s^2 + 4} \right) + 10}{(2+s)(3+s) - 2} = \frac{(2+s)(25s^2 + 60s + 100) + 10(s^2 + 4)}{(s^2 + 4)(s+1)(s+4)} \\ &= \frac{25s^3 + 120s^2 + 220s + 240}{(s^2 + 4)(s+1)(s+4)} \end{aligned}$$

Next, partial fraction expansion gives

$$V_2(s) = \frac{A}{s+j2} + \frac{A^*}{s-j2} + \frac{B}{s+1} + \frac{C}{s+4}$$

where

$$A = \left. \frac{25s^3 + 120s^2 + 220s + 240}{(s+1)(s+4)(s-j2)} \right|_{s=-j2} = \frac{-240 - j240}{-40} = 6 + j6$$

$$A^* = 6 - j6$$

$$B = \left. \frac{25s^3 + 120s^2 + 220s + 240}{(s^2 + 4)(s+4)} \right|_{s=-1} = \frac{115}{15} = \frac{23}{3}$$

$$C = \left. \frac{25s^3 + 120s^2 + 220s + 240}{(s^2 + 4)(s+1)} \right|_{s=-4} = \frac{-320}{-60} = \frac{16}{3}$$

Then

$$V_2(s) = \frac{6+j6}{s+j2} + \frac{6-j6}{s-j2} + \frac{23/3}{s+1} + \frac{16/3}{s+4}$$

Finally

$$v_2(t) = 12 \cos 2t + 12 \sin 2t + \frac{23}{3} e^{-t} + \frac{16}{3} e^{-4t} \text{ V } \quad t \geq 0$$

Ex. 14.7-3

Taking Laplace Transform of the differential equation:

$$s^2 F(s) = s f(0) - f'(0) + 5 [s F(s) - f(0)] + 6 F(s) = \frac{10}{s+3}$$

Using the given initial conditions

$$(s^2 + 5s + 6) F(s) = \frac{10}{s+3} + 2s + 10 = \frac{2s^2 + 16s + 40}{s+3}$$

$$F(s) = \frac{2s^2 + 16s + 40}{(s+3)(s+2)(s+3)} = \frac{A}{(s+3)^2} + \frac{B}{s+3} + \frac{C}{s+2}$$

where $A = -10$, $B = -14$, and $C = 16$. Then

$$F(s) = \frac{-10}{(s+3)^2} + \frac{-14}{s+3} + \frac{16}{s+2} \Rightarrow f(t) = -10te^{-3t} - 14e^{-3t} + 16e^{-2t} \quad \text{for } t \geq 0$$

Ex. 14.8-1

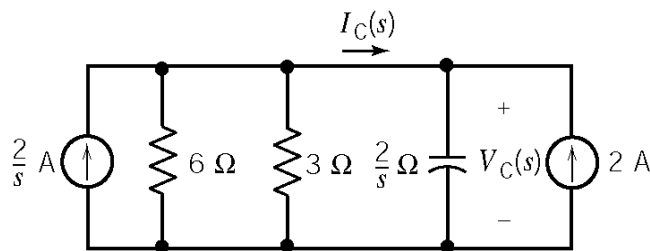

KCL at top node:

$$\frac{V_C(s)}{3} + \frac{s}{2} V_C(s) = \frac{2}{s} + 2$$

$$V_C(s) = \frac{6}{s} - \frac{2}{s + \frac{2}{3}}$$

$$v_C(t) = (6 - 2e^{-(2/3)t}) u(t) \text{ V}$$

$$I_C(s) = \frac{V_C(s)}{\frac{2}{s}} - 2 = \frac{\frac{2}{3}}{s + \frac{2}{3}} \Rightarrow i_C(t) = \frac{2}{3} e^{-(2/3)t} u(t) \text{ A}$$

Ex. 14.8-2

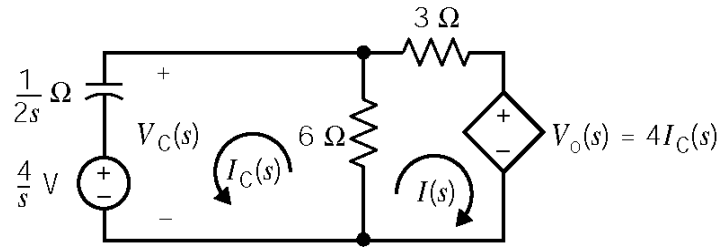

Mesh Equations:

$$-\frac{4}{s} - \frac{1}{2s}I_C(s) - 6(I(s) - I_C(s)) = 0 \Rightarrow -\frac{4}{s} = \left(6 + \frac{1}{2s}\right)I_C(s) + 6I(s)$$

$$6(I(s) - I_C(s)) + 3I(s) + 4I_C(s) = 0 \Rightarrow I(s) = -\frac{10}{9}I_C(s)$$

Solving for $I_C(s)$:

$$-\frac{4}{s} = \left(-\frac{2}{3} + \frac{1}{2s}\right)I_C(s) \Rightarrow I_C(s) = \frac{6}{s - \frac{3}{4}}$$

So $V_o(s)$ is

$$V_o(s) = 4I_C(s) = \frac{24}{s - \frac{3}{4}}$$

Back in the time domain:

$$v_o(t) = 24e^{0.75t} u(t) \text{ V}$$

Ex. 14.8-3

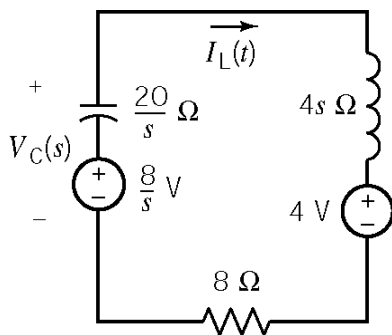

KVL:

$$\frac{8}{s} + 4 = \left(\frac{20}{s} + 8 + 4s\right)I_L(s)$$

so

$$I_L(s) = \frac{2+s}{s^2+2s+5} = \frac{(s+1)+1}{(s+1)^2+4}$$

Taking the inverse Laplace transform:

$$i(t) = \left(e^{-t} \cos 2t + \frac{1}{2}e^{-t} \sin 2t\right) u(t) \text{ A}$$

Ex. 14.9-1

(a) *impulse response* = $\mathcal{L}^{-1}\left[\frac{5}{s+5} - \frac{10}{s+10}\right] = (5e^{-5t} - 10e^{-10t})u(t)$

(b) *step response* = $\mathcal{L}^{-1}\left[\frac{1}{s+10} - \frac{1}{s+5}\right] = (e^{-10t} - e^{-5t})u(t)$

Ex. 14.9-2

$$H(s) = \mathcal{L}[5e^{-2t} \sin(4t)u(t)] = \frac{5(4)}{(s+2)^2 + 4^2} = \frac{20}{s^2 + 4s + 20}$$

$$\text{step response} = \mathcal{L}^{-1}\left[\frac{H(s)}{s}\right] = \mathcal{L}^{-1}\left[\frac{1}{s} - \frac{s+4}{s^2 + 4s + 20}\right] = (1 - e^{-2t}(\cos 4t - \frac{1}{2}\sin 4t))u(t)$$

Ex. 14.10-1

Voltage division yields

$$\begin{aligned} H(s) = \frac{V_c(s)}{V_1(s)} &= \frac{(8)\left(\frac{2}{s}\right)}{8 + \frac{2}{s}} \\ &= \frac{(8)\left(\frac{2}{s}\right)}{2 + \frac{8}{s}} \\ &= \frac{\frac{16}{s}}{16 + \frac{4}{s} + \frac{16}{s}} = \frac{16}{16s + 20} = \frac{1}{s + 1.25} \end{aligned}$$

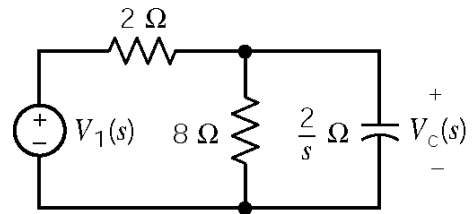

so

$$h(t) = \mathcal{L}^{-1}[H(s)] = 1.25e^{-1.25t}u(t)$$

Ex. 14.10-2

$$h(t) = e^{-2t} \Rightarrow H(s) = \frac{1}{s+2}$$

$$f(t) = u(t) \Rightarrow F(s) = \frac{1}{s}$$

$$h(t) * f(t) = \mathcal{L}^{-1} [H(s) F(s)] = \mathcal{L}^{-1} \left[\frac{1}{s(s+2)} \right] = \mathcal{L}^{-1} \left[\frac{1/2}{s} + \frac{-1/2}{s+2} \right] = \left(\frac{1}{2} - e^{-2t} \right) u(t)$$

Ex. 14.11-1

The poles of the transfer function are $p_{1,2} = \frac{-(3-k) \pm \sqrt{(3-k)^2 - 8}}{2}$.

a.) When $k = 2 \text{ V/V}$, the poles are $p_{1,2} = \frac{-1 \pm \sqrt{-7}}{2}$ so the circuit is stable. The transfer function is

$$H(s) = \frac{V_o(s)}{V_i(s)} = \frac{2s}{s^2 + s + 2}$$

The circuit is stable when $k = 2 \text{ V/V}$ so we can determine the network function from the transfer function by letting $s = j\omega$.

$$\frac{V_o(\omega)}{V_i(\omega)} = \mathbf{H}(\omega) = H(s) \Big|_{s=j\omega} = \frac{2s}{s^2 + s + 2} \Big|_{s=j\omega} = \frac{2j\omega}{(2 - \omega^2) + j\omega}$$

The input is $v_i(t) = 5 \cos 2t \text{ V}$. The phasor of the steady state response is determined by multiplying the phasor of the input by the network function evaluated at $\omega = 2 \text{ rad/s}$.

$$V_o(\omega) = \mathbf{H}(\omega) \Big|_{\omega=2} \times V_i(\omega) = \left(\frac{2j\omega}{(2 - \omega^2) + j\omega} \Big|_{\omega=2} \right) (5 \angle 0^\circ) = \left(\frac{j4}{-2 + j2} \right) (5 \angle 0^\circ) = 7.07 \angle -45^\circ$$

The steady state response is $v_o(t) = 7.07 \cos(2t - 45^\circ) \text{ V}$.

b. When $k = 3 - 2\sqrt{2}$, the poles are $p_{1,2} = \frac{-2\sqrt{2} \pm \sqrt{0}}{2} = -\sqrt{2}, -\sqrt{2}$ so the circuit is stable. The transfer function is

$$H(s) = \frac{0.17s}{(s + \sqrt{2})^2} = \frac{0.17}{(s + \sqrt{2})} - \frac{0.17\sqrt{2}}{(s + \sqrt{2})^2}$$

The impulse response is

$$h(t) = \mathcal{L}^{-1}[H(s)] = 0.17 e^{-\sqrt{2}t} (1 - \sqrt{2}t) u(t)$$

We see that when $k = 3 - 2\sqrt{2}$ the circuit is stable and $\lim_{t \rightarrow \infty} |h(t)| = 0$.

c. When, $k = 3 + 2\sqrt{2}$ the poles are $p_{1,2} = \frac{2\sqrt{2} \pm \sqrt{0}}{2} = \sqrt{2}, \sqrt{2}$ so the circuit is not stable. The transfer function is

$$H(s) = \frac{5.83s}{(s - \sqrt{2})^2} = \frac{5.83}{(s - \sqrt{2})} + \frac{5.83\sqrt{2}}{(s - \sqrt{2})^2}$$

The impulse response is

$$h(t) = \mathcal{L}^{-1}[H(s)] = 5.83 e^{\sqrt{2}t} (1 + \sqrt{2}t) u(t)$$

We see that when $k = 3 + 2\sqrt{2}$ the circuit is unstable and $\lim_{t \rightarrow \infty} |h(t)| = \infty$.

Ex. 14.12-1

For the poles to be in the left half of the s-plane, the s-term needs to be positive.

$$\begin{aligned} V_0(s) &= 0.1 \left[\frac{2}{s} - \left(2 \frac{s+5}{(s+5)^2 + 10^2} + \frac{10}{(s+5)^2 + 10^2} \right) \right] = 0.1 \left[\frac{2}{s} - \frac{2s+20}{s^2+10s+125} \right] \\ &= 0.1 \frac{2(s^2+10s+125) - (2s+20)s}{s^2+10s+125} \\ &= 0.1 \frac{250}{s^2+10s+125} = \frac{25}{s^2+10s+125} \end{aligned}$$

These specifications are consistent.

Problems

Section 14-3: Laplace Transform

P14.3-1

$$\left. \begin{array}{l} \mathcal{L}[A f_1(t)] = A F_1(s) \\ f_1(t) = \cos(\omega t) \Rightarrow F_1(s) = \frac{s}{s^2 + \omega^2} \end{array} \right\} \Rightarrow F(s) = \frac{As}{s^2 + \omega^2}$$

P14.3-2

$$\mathcal{L}^{-1}[t^n] = \frac{n!}{s^{n+1}} \quad F(s) = \mathcal{L}^{-1}[t^1] = \frac{1!}{s^{1+1}} = \frac{1}{s^2}$$

P14.3-3

$$\text{Linearity: } \mathcal{L}[a_1 f_1(t) + a_2 f_2(t)] = a_1 F_1(s) + a_2 F_2(s)$$

$$\text{Here } a_1 = a_2 = 1$$

$$\mathcal{L}[f_1(t)] = \mathcal{L}[e^{-3t}] = \frac{1}{s+3} = F_1(s)$$

$$\mathcal{L}[f_2(t)] = \mathcal{L}[t] = \frac{1}{s^2} = F_2(s)$$

$$\text{so } F(s) = \frac{1}{s+3} + \frac{1}{s^2}$$

P14.3-4

$$f(t) = A(1 - e^{-bt})u(t) = \mathcal{L}[A f_1(t)] = A F_1(s)$$

$$f_1(t) = A(1 - e^{-bt})u(t) = 1u(t) - e^{-bt}u(t) = f_2(t) + f_3(t)$$

$$F_2(s) = \frac{1}{s}, \quad F_3(s) = \frac{-1}{s+b}$$

$$\therefore F(s) = A \left[\frac{1}{s} - \frac{1}{s+b} \right] = \frac{Ab}{s(s+b)}$$

Section 14-4: Impulse Function and Time Shift Property

P14.4-1

$$f(t) = A[u(t) - u(t-T)]$$

$$F(s) = A\mathcal{L}[u(t)] - A\mathcal{L}[u(t-T)] = \frac{A}{s} - \frac{Ae^{-sT}}{s} = A \frac{(1 - e^{-sT})}{s}$$

P14.4-2

$$f(t) = 1[u(t) - u(t-T)]e^{at} \Rightarrow F(s) = \mathcal{L}[e^{at}[u(t) - u(t-T)]]$$

$$\left. \begin{aligned} \mathcal{L}[u(t) - u(t-T)] &= \frac{1 - e^{-sT}}{s} \\ \mathcal{L}[e^{at}g(t)] &= G(s-a) \end{aligned} \right\} \Rightarrow F(s) = \frac{1 - e^{(s-a)T}}{(s-a)}$$

P14.4-3

(a) $F(s) = \frac{2}{(s+3)^3}$

(b) $f(t) = \delta(t-T)u(t-T) \Rightarrow F(s) = e^{-sT} \mathcal{L}[\delta(t)] = e^{-sT}$

(c) $F(s) = \frac{5}{(s+4)^2 + (5)^2} = \frac{5}{(s^2 + 8s + 16) + 25} = \frac{5}{s^2 + 8s + 41}$

P14.4-4

$$g(t) = e^{-t}u(t-0.5) = e^{-(t+(0.5-0.5))}u(t-0.5) = e^{-0.5}e^{-(t-0.5)}u(t-0.5)$$

$$\mathcal{L}[e^{-0.5}e^{-(t-0.5)}u(t-0.5)] = e^{-0.5} \mathcal{L}[e^{-(t-0.5)}u(t-0.5)] = e^{-0.5}e^{-0.5s} \mathcal{L}[e^{-t}u(t)] = \frac{e^{0.5}e^{-0.5s}}{s+1} = \frac{e^{0.5-0.5s}}{s+1}$$

P14.4-5

$$\mathcal{L}\left[-\frac{t-T}{T}u(t-T)\right] = e^{-sT} \mathcal{L}\left[-\frac{t}{T}u(t)\right] = \frac{e^{-sT}}{T} \mathcal{L}[-tu(t)] = \frac{e^{-sT}}{Ts^2}$$

Section 14-5: Inverse Laplace Transform

P14.5-1

$$F(s) = \frac{s+3}{s^3+3s^2+6s+4} = \frac{s+3}{(s+1)\left[(s+1)^2+3\right]} = \frac{A}{s+1} + \frac{Bs+C}{s^2+2s+4}$$

where

$$A = \left. \frac{s+3}{(s+1)^2+3} \right|_{s=-1} = \frac{2}{3}$$

Then

$$\frac{(s+3)}{(s+1)(s^2+2s+4)} = \frac{\frac{2}{3}}{s+1} + \frac{Bs+C}{s^2+2s+4} \Rightarrow (s+3) = \left(\frac{2}{3} + B\right)s^2 + \left(\frac{4}{3} + B + C\right)s + \frac{8}{3} + C$$

Equating coefficient yields

$$\begin{aligned} s^2: \quad 0 &= \frac{2}{3} + B \Rightarrow B = -\frac{2}{3} \\ s: \quad 1 &= \frac{4}{3} - \frac{2}{3} + C \Rightarrow C = \frac{1}{3} \end{aligned}$$

Then

$$F(s) = \frac{\frac{2}{3}}{s+1} + \frac{-\frac{2}{3}s + \frac{1}{3}}{(s+1)^2+3} = \frac{\frac{2}{3}}{s+1} + \frac{-\frac{2}{3}(s+1)}{(s+1)^2+3} + \frac{\frac{1}{\sqrt{3}}\sqrt{3}}{(s+1)^2+3}$$

Taking the inverse Laplace transform yields

$$f(t) = \frac{2}{3}e^{-t} - \frac{2}{3}e^{-t} \cos \sqrt{3}t + \frac{1}{\sqrt{3}}e^{-t} \sin \sqrt{3}t$$

P14.5-2

$$F(s) = \frac{s^2 - 2s + 1}{s^3 + 3s^2 + 4s + 2} = \frac{s^2 - 2s + 1}{(s+1)(s+1-j)(s+1+j)} = \frac{a}{s+1-j} + \frac{a^*}{s+1+j} + \frac{b}{s+1}$$

where

$$b = \left. \frac{s^2 - 2s + 1}{(s+1)^2 + 1} \right|_{s=-1} = 4$$

$$a = \left. \frac{s^2 - 2s + 1}{(s+1)(s+1+j)} \right|_{s=-1+j} = \frac{3-j}{-2} = -\frac{3}{2} + j2$$

$$a^* = -\frac{3}{2} - j2$$

Then

$$F(s) = \frac{-\frac{3}{2} + j2}{s+1-j} + \frac{-\frac{3}{2} - j2}{s+1+j} + \frac{4}{s+1}$$

Next

$$m = \sqrt{(-3/2)^2 + (2)^2} = \frac{5}{2} \quad \text{and} \quad \theta = \tan^{-1} \left(\frac{2}{-3/2} \right) = 126.9^\circ$$

From Equation 14.5-8

$$f(t) = [5e^{-t} \cos(t+127^\circ) + 4e^{-t}]u(t)$$

P14.5-3

$$F(s) = \frac{5s-1}{(s+1)^2(s-2)} = \frac{A}{s+1} + \frac{B}{(s+1)^2} + \frac{C}{s-2}$$

where

$$B = \left. \frac{5s-1}{s-2} \right|_{s=-1} = 2 \quad \text{and} \quad C = \left. \frac{5s-1}{(s+1)^2} \right|_{s=2} = 1$$

Then

$$A = \left. \frac{d}{ds} [(s+1)^2 F(s)] \right|_{s=-1} = \left. \frac{-9}{(s-2)^2} \right|_{s=-1} = -1$$

Finally

$$F(s) = \frac{-1}{s+1} + \frac{2}{(s+1)^2} + \frac{1}{s-2} \Rightarrow f(t) = [-e^{-t} + 2te^{-t} + e^{2t}]u(t)$$

P14.5-4

$$Y(s) = \frac{1}{(s+1)(s^2+2s+2)} = \frac{1}{(s+1)\left[(s+1)^2+1\right]} = \frac{A}{s+1} + \frac{Bs+C}{(s+1)^2+1}$$

where

$$A = \left. \frac{1}{s^2+2s+2} \right|_{s=-1} = 1$$

Next

$$\begin{aligned} \frac{1}{(s+1)(s^2+2s+2)} &= \frac{1}{s+1} + \frac{Bs+C}{s^2+2s+2} \Rightarrow 1 = s^2+2s+2 + (Bs+C)(s+1) \\ &\Rightarrow 1 = (B+1)s^2 + (B+C+2)s + C + 2 \end{aligned}$$

Equating coefficients:

$$\begin{aligned} s^2 : 0 &= B+1 \Rightarrow B = -1 \\ s : 0 &= B+C+2 \Rightarrow C = -1 \end{aligned}$$

Finally

$$Y(s) = \frac{1}{s+1} - \frac{s+1}{(s+1)^2+1} \Rightarrow y(t) = [e^{-t} - e^{-t} \cos t] u(t)$$

P14.5-5

$$F(s) = \frac{2(s+3)}{(s+1)(s^2+2s+5)} = \frac{1}{s+1} + \frac{-(s+1)}{(s+1)^2+4} + \frac{2}{(s+1)^2+4}$$

$$f(t) = [e^{-t} - e^{-t} \cos(2t) + e^{-t} \sin(2t)] u(t)$$

P14.5-6

$$F(s) = \frac{2(s+3)}{s(s+1)(s+2)} = \frac{A}{s} + \frac{B}{s+1} + \frac{C}{s+2}$$

where

$$A = sF(s) \Big|_{s=0} = \left. \frac{2(s+3)}{(s+1)(s+2)} \right|_{s=0} = 3, \quad B = (s+1)F(s) \Big|_{s=-1} = \left. \frac{2(s+3)}{s(s+2)} \right|_{s=-1} = -4$$

and

$$(s+2)F(s) \Big|_{s=-2} = \left. \frac{2(s+3)}{s(s+1)} \right|_{s=-2} = C = 1$$

Finally

$$F(s) = \frac{3}{s} + \frac{-4}{s+1} + \frac{1}{s+2} \Rightarrow f(t) = (3 - 4e^{-t} + e^{-2t}) u(t)$$

Section 14-6: Initial and Final Value Theorems

P14.6-1

$$(a) \quad f(0) = \lim_{s \rightarrow \infty} sF(s) = \lim_{s \rightarrow \infty} \frac{2s^2 - 3s + 4}{s^2 + 3s + 2} = \frac{2s^2}{s^2} = 2$$

$$(b) \quad f(\infty) = \lim_{s \rightarrow 0} sF(s) = \frac{4}{2} = 2$$

P14.6-2

Initial value:
$$v(0) = \lim_{s \rightarrow \infty} sV(s) = \lim_{s \rightarrow \infty} \frac{s(s+16)}{s^2 + 4s + 12} = \lim_{s \rightarrow \infty} \frac{s^2 + 16s}{s^2 + 4s + 12} = 1$$

Final value:
$$v(\infty) = \lim_{s \rightarrow 0} s \left(\frac{s+16}{s^2 + 4s + 12} \right) = \lim_{s \rightarrow 0} \frac{s^2 + 16s}{s^2 + 4s + 12} = 0$$

(Check: $V(s)$ is stable because $\text{Re}\{p_i\} < 0$ since $p_i = -2 \pm 2.828j$. We expect the final value to exist.)

P14.6-3

Initial value:
$$v(0) = \lim_{s \rightarrow \infty} sV(s) = \lim_{s \rightarrow \infty} \frac{s^2 + 10s}{3s^3 + 2s^2 + 1} = 0$$

Final value:
$$v(\infty) = \lim_{s \rightarrow 0} sV(s) = \lim_{s \rightarrow 0} \frac{s(s+10)}{s(3s^2 + 2s + 1)} = 10$$

(Check: $V(s)$ is stable because $p_i = -0.333 \pm 0.471i$. We expect the final value to exist.)

P14.6-4

Initial value:
$$f(0) = \lim_{s \rightarrow \infty} sF(s) = \lim_{s \rightarrow \infty} \frac{-2s^2 - 14s}{s^2 - 2s + 10} = -2$$

Final value: $F(s)$ is not stable because $\text{Re}\{p_1\} > 0$ since $p_i = 1 \pm 3i$. No final value exists.

Section 14-7: Solution of Differential Equations Describing a Circuit

P14.7-1

KVL:

$$50i + 0.001 \frac{di}{dt} + v = 2e^{-2 \times 10^4 t}$$

The capacitor current and voltage are related by

$$i = (2.5 \times 10^{-6}) \frac{dv}{dt}$$

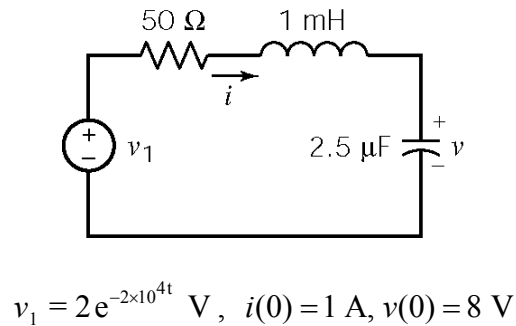

$$v_1 = 2e^{-2 \times 10^4 t} \text{ V}, \quad i(0) = 1 \text{ A}, \quad v(0) = 8 \text{ V}$$

Taking the Laplace transforms of these equations yields

$$50 I(s) + 0.001 [s I(s) - i(0)] + V(s) = \frac{2}{s + 2 \times 10^4}$$

$$I(s) = (2.5 \times 10^{-6}) [s V(s) - v(0)]$$

Solving for $I(s)$ yields

$$I(s) = \frac{s^2 + 1.4 \times 10^4 s - 1.6 \times 10^8}{(s + 10^4)(s + 2 \times 10^4)(s + 4 \times 10^4)} = \frac{A}{s + 10^4} + \frac{B}{s + 2 \times 10^4} + \frac{C}{s + 4 \times 10^4}$$

where

$$A = (s + 10^4) I(s) \Big|_{s = -10^4} = \frac{s^2 + 1.4 \times 10^4 s - 1.6 \times 10^8}{(s + 2 \times 10^4)(s + 4 \times 10^4)} \Big|_{s = -10^4} = \frac{-2 \times 10^8}{3 \times 10^8} = -\frac{2}{3}$$

$$B = (s + 2 \times 10^4) I(s) \Big|_{s = -2 \times 10^4} = \frac{s^2 + 1.4 \times 10^4 s - 1.6 \times 10^8}{(s + 10^4)(s + 4 \times 10^4)} \Big|_{s = -2 \times 10^4} = \frac{.4 \times 10^8}{2 \times 10^8} = \frac{1}{5}$$

$$C = (s + 4 \times 10^4) I(s) \Big|_{s = -4 \times 10^4} = \frac{s^2 + 1.4 \times 10^4 s - 1.6 \times 10^8}{(s + 10^4)(s + 2 \times 10^4)} \Big|_{s = -4 \times 10^4} = \frac{8.8 \times 10^8}{6 \times 10^8} = \frac{22}{15}$$

Then

$$I(s) = -\frac{2/3}{s + 10^4} + \frac{1/5}{s + 2 \times 10^4} + \frac{22/15}{s + 4 \times 10^4} \Rightarrow i(t) = \frac{1}{15} [-10e^{-10^4 t} + 3e^{-2 \times 10^4 t} + 22e^{-4 \times 10^4 t}] u(t) \text{ A}$$

P14.7-2

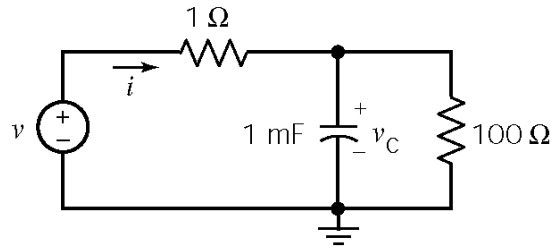

We are given $v(t) = 160 \cos 400t$.

The capacitor is initially uncharged, so $v_C(0) = 0$ V. Then

$$i(0) = \frac{160 \cos(400 \times 0) - 0}{1} = 160 \text{ A}$$

KCL yields

$$10^{-3} \frac{dv_C}{dt} + \frac{v_C}{100} = i$$

Apply Ohm's law to the 1Ω resistor to get

$$i = \frac{v - v_C}{1} \Rightarrow v_C = v - i$$

Solving yields

$$\frac{di}{dt} + 1010i = 1600 \cos 400t - (6.4 \times 10^4) \sin 400t$$

Taking the Laplace transform yields

$$sI(s) - i(0) + (1010)I(s) = \frac{1600s}{s^2 + (400)^2} - \frac{(6.4 \times 10^2)(400)}{s^2 + (400)^2}$$

so

$$I(s) = \frac{160}{s + 1010} + \frac{1600s - 2.5 \times 10^7}{(s + 1010)[s^2 + (400)^2]}$$

Next

$$\frac{1600s - 2.5 \times 10^7}{(s + 1010)[s^2 + (400)^2]} = \frac{A}{s + 1010} + \frac{B}{s + j400} + \frac{B^*}{s - j400}$$

where

$$A = \left. \frac{1600s - 2.5 \times 10^7}{s^2 + (400)^2} \right|_{s = -1010} = -23.1,$$

$$B = \left. \frac{1600s - 2.5 \times 10^7}{(s + 1010)(s - j400)} \right|_{s = -j400} = \frac{2.56 \times 10^7 \angle 1.4^\circ}{8.69 \times 10^5 \angle 68.4^\circ} = 11.5 - j27.2 \text{ and } B^* = 11.5 + j27.2$$

Then

$$I(s) = \frac{136.9}{s + 1010} + \frac{11.5 - j27.2}{s + j400} + \frac{11.5 + j27.2}{s - j400}$$

Finally

$$\begin{aligned} i(t) &= 136.9e^{-1010t} + 2(11.5) \cos 400t - 2(27.2) \sin 400t \text{ for } t > 0 \\ &= 136.9e^{-1010t} + 23.0 \cos 400t - 54.4 \sin 400t \text{ for } t > 0 \end{aligned}$$

P14.7-3

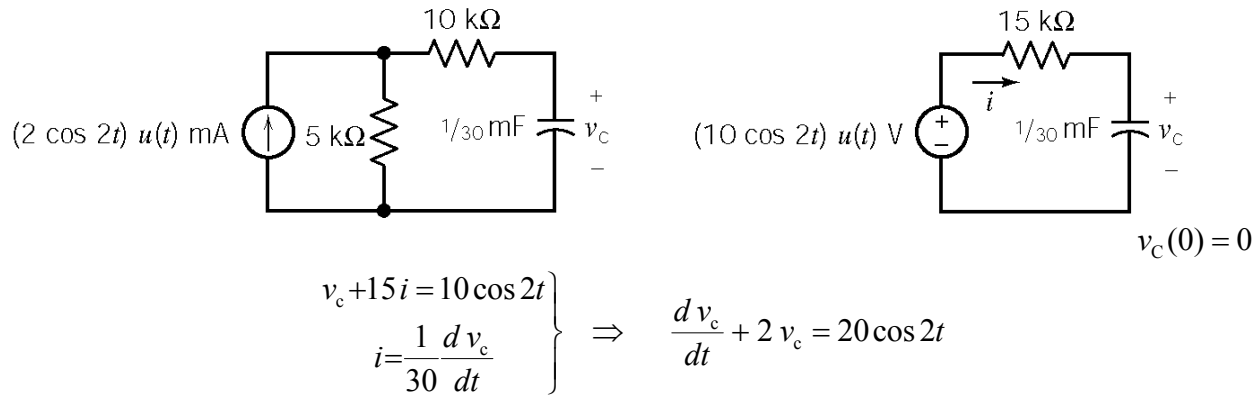

Taking the Laplace Transform yields:

$$sV_c(s) - v_c(0) + 2V_c(s) = 20 \frac{s}{s^2 + 4} \Rightarrow V_c(s) = \frac{20s}{(s+2)(s^2+4)} = \frac{A}{s+2} + \frac{B}{s+j2} + \frac{B^*}{s-j2}$$

where

$$A = \frac{20s}{s^2+4} \Big|_{s=-2} = \frac{-40}{8} = -5, \quad B = \frac{20s}{(s+2)(s-j2)} \Big|_{s=-j2} = \frac{j5}{1+j} = \frac{5}{2} + j\frac{5}{2} \quad \text{and} \quad B^* = \frac{5}{2} - j\frac{5}{2}$$

Then

$$V_c(s) = \frac{-5}{s+2} + \frac{5+j\frac{5}{2}}{s+j2} + \frac{5-j\frac{5}{2}}{s-j2} \Rightarrow v_c(t) = -5e^{-2t} + 5(\cos 2t + \sin 2t) \text{ V}$$

P14.7-4

$$v_c + 12i_L + 2 \frac{di_L}{dt} = -8 \quad \text{and} \quad i_L = C \frac{dv_c}{dt}$$

Taking the Laplace transform yields

$$V_c(s) + 12I_L(s) + 2[sI_L(s) - i_L(0)] = -\frac{8}{s}$$

$$I_L(s) = C[sV_c(s) - v_c(0)]$$

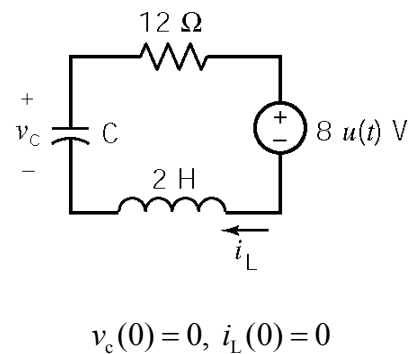

Solving yields

$$V_c(s) = \frac{-4C}{s\left(s^2 + 6s + \frac{C}{2}\right)}$$

(a) $C = \frac{1}{18} \text{ F}$

$$V_c(s) = \frac{-72}{s(s+3)^2} = \frac{a}{s} + \frac{b}{s+3} + \frac{c}{(s+3)^2}$$

$$a = -8, b = 8, \text{ and } c = 24 \Rightarrow V_c(s) = \frac{-8}{s} + \frac{8}{s+3} + \frac{24}{(s+3)^2}$$

$$v_c(t) = -8 + 8e^{-3t} + 24te^{-3t}$$

(b) $C = \frac{1}{10} \text{ F}$

$$V_c(s) = \frac{-40}{s(s+1)(s+5)} = \frac{a}{s} + \frac{b}{s+1} + \frac{c}{s+5}$$

$$a = -8, b = 10, \text{ and } c = -2 \Rightarrow V_c(s) = \frac{-8}{s} + \frac{10}{s+1} + \frac{-2}{s+5}$$

$$v_c(t) = -8 + 10e^{-t} - 2e^{-5t}$$

P14.7-5

$$v_c(0^-) = 10 \text{ V}, i_L(0^-) = 0 \text{ A}$$

$$i = (5 \times 10^{-6}) \frac{dv_c}{dt} \text{ and } 400i + 1 \frac{di}{dt} + v_c = 0$$

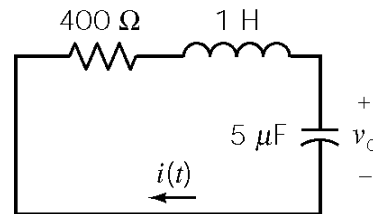

Taking Laplace transforms yields

$$\left. \begin{aligned} I(s) &= (5 \times 10^{-6})(sV_c(s) - 10) \\ 400I(s) + (sI(s) - 0) + V_c(s) &= 0 \end{aligned} \right\} \Rightarrow I(s) = \frac{-10}{s^2 + 400s + 2 \times 10^5} = \frac{\left(-\frac{1}{40}\right)400}{(s+200)^2 + 400^2}$$

so

$$i(t) = -\frac{1}{40} e^{-200t} \sin(400t) u(t) \text{ A}$$

Section 14-8: Circuit Analysis Using Impedance and Initial Conditions

P14.8-1

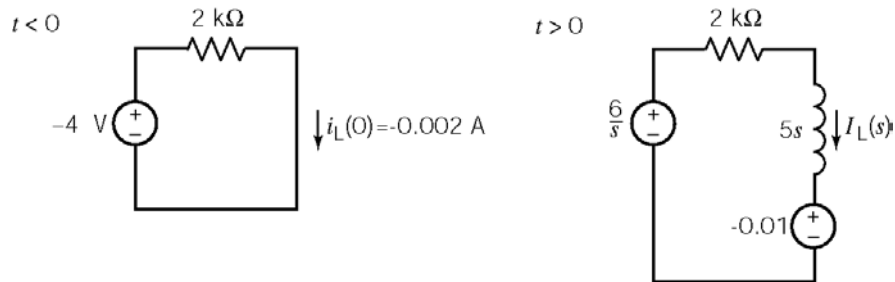

$$I_L(s) = \frac{\frac{6}{s} - 0.010}{5s + 2000} = \frac{\frac{6}{s} - 0.002s}{s(s+400)} = \frac{.003}{s} = \frac{.005}{s+400}$$

$$i_L(t) = \begin{cases} 2 \text{ mA} & t < 0 \\ 3 - 5e^{-400t} \text{ mA} & t > 0 \end{cases}$$

P14.8-2

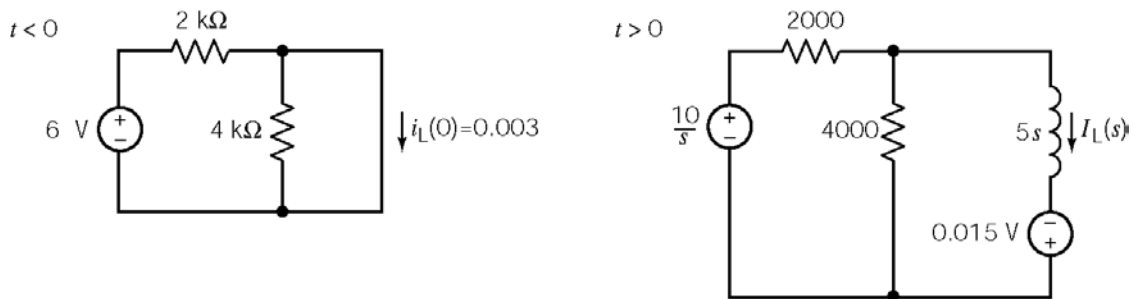

$$0 = \frac{V_L(s) - \frac{10}{s}}{2000} + \frac{V_L(s)}{4000} + \frac{V_L(s) - (-0.015)}{5s} \Rightarrow V_L(s) = \frac{\frac{8}{3}}{s + \frac{4000}{15}}$$

$$I_L(s) = \frac{V_L(s) + 0.015}{5s} = \frac{\frac{8}{15}}{s \left(s + \frac{4000}{15} \right)} + 0.015 = \frac{0.005}{s} - \frac{0.002}{s + \frac{4000}{15}}$$

$$i_L(t) = 5 - 3e^{-\frac{4000}{15}t} \text{ mA}, t > 0$$

P14.8-3

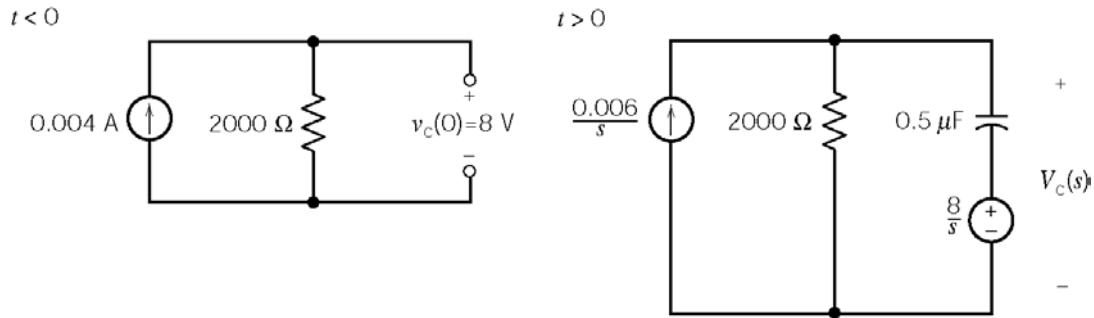

$$-\frac{0.006}{s} + \frac{V_c(s)}{2000} + \frac{V_c(s) - \frac{8}{s}}{\frac{10^6}{.5s}} = 0$$

$$-\frac{6000}{s} + 500V_c(s) + 0.5s \left(V_c(s) - \frac{8}{s} \right) = 0$$

$$V_c(s) = \frac{8s + 12000}{s(s+1000)} = \frac{12}{s} - \frac{4}{s+1000}$$

$$V_c(t) = 12 - 4e^{-1000t} \text{ V, } t > 0$$

P14.8-4

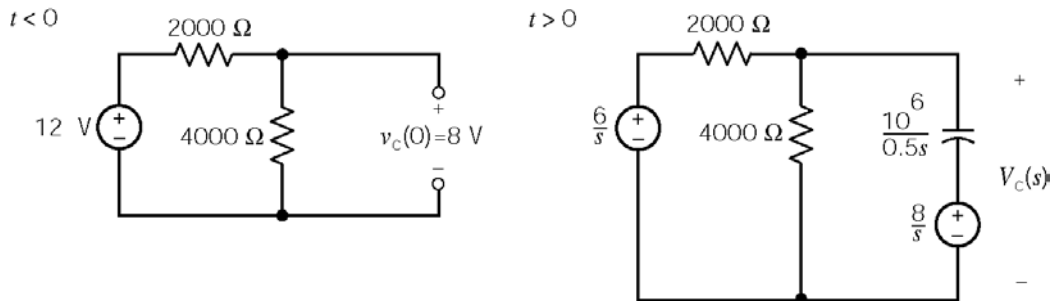

$$\frac{V_c(s) - \frac{6}{s}}{2000} + \frac{V_c(s)}{4000} + \left(\frac{0.5s}{10^6} \right) \left(V_c(s) - \frac{8}{s} \right) = 0$$

$$500 \left(V_c(s) - \frac{6}{s} \right) + 250V_c(s) + 0.5s \left(V_c(s) - \frac{8}{s} \right) = 0$$

$$V_c(s) = \frac{6000 + 8s}{s(s+1500)} = \frac{4}{s} + \frac{4}{s+1500}$$

$$v_c(t) = 4 + 4e^{-1500t} \text{ V, } t > 0$$

P14.8-5

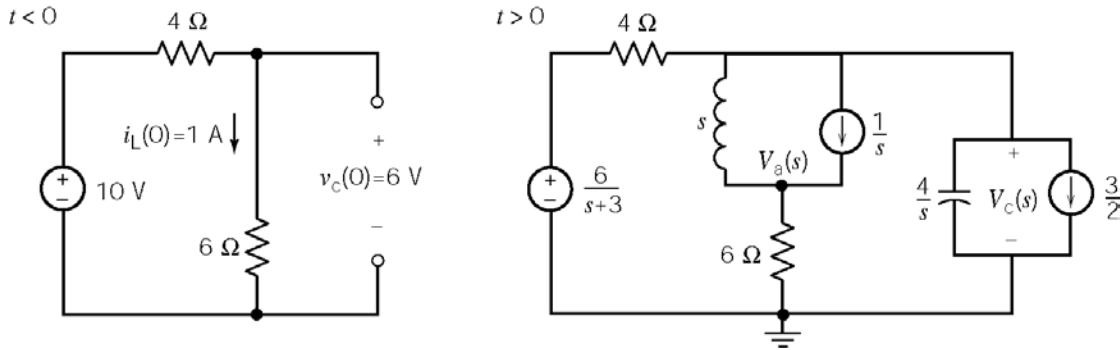

Node equations:

$$\frac{V_a(s) - V_C(s)}{s} + \frac{V_a(s)}{6} = \frac{1}{s} \Rightarrow V_a(s) = \frac{6}{s+6} V_C(s) + \frac{6}{s+6}$$

$$\frac{V_C(s) - \frac{6}{s+3}}{4} + \frac{V_C(s) - \left(\frac{6}{s+6} V_C(s) + \frac{6}{s+6}\right)}{s} + \frac{1}{s} + \frac{s}{4} V_C(s) - \frac{3}{2} = 0$$

After quite a bite of algebra:

$$V_C(s) = \frac{6s^2 + 56s + 132}{(s+2)(s+3)(s+5)}$$

Partial fraction expansion:

$$V_C(s) = \frac{6s^2 + 56s + 132}{(s+3)(s+2)(s+5)} = \frac{44}{s+2} - \frac{9}{s+3} + \frac{1}{s+5}$$

Inverse Laplace transform:

$$v_C(t) = 44/3 e^{-2t} - 9e^{-3t} + (1/3)e^{-5t} \text{ V}$$

P14.8-6

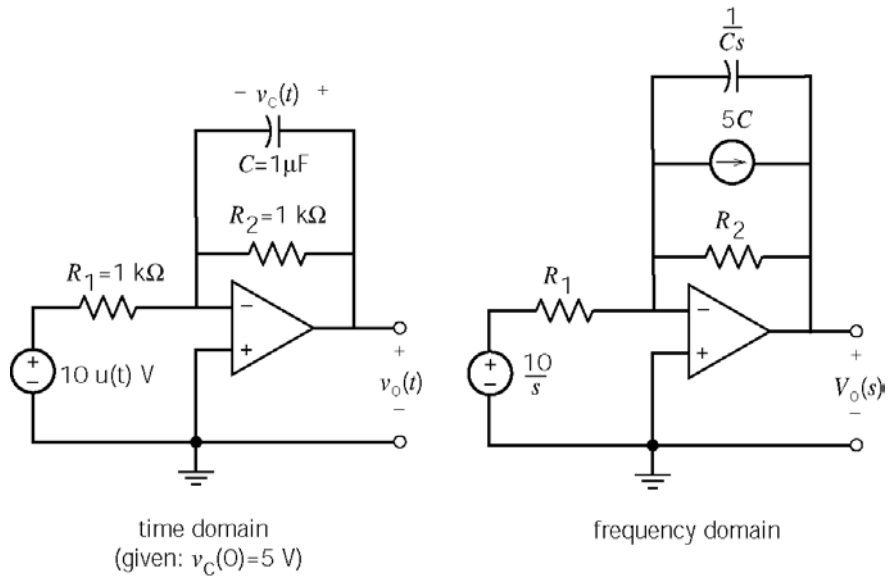

Write a node equation in the frequency domain:

$$\frac{10}{s} = \frac{V_o(s)}{R_2} - 5C + \frac{V_o(s)}{\frac{1}{Cs}} \Rightarrow V_o(s) = \frac{\frac{10}{R_1 C} + 5s}{s\left(s + \frac{1}{R_2 C}\right)} = \frac{10 \frac{R_2}{R_1}}{s} + \frac{5 - 10 \frac{R_2}{R_1}}{s + \frac{1}{R_2 C}}$$

Inverse Laplace transform:

$$v_o(t) = 10 \frac{R_2}{R_1} + \left(5 - 10 \frac{R_2}{R_1}\right) e^{-t/R_2 C} = 10 - 5 e^{-1000t} \text{ V for } t > 0$$

P14.8-7

Here are the equations describing the coupled coils:

$$v_1(t) = L_1 \frac{di_1}{dt} + M \frac{di_2}{dt} \Rightarrow V_1(s) = 3(s I_1(s) - 2) + (s I_2(s) - 3) = 3s I_1(s) + s I_2(s) - 9$$

$$v_2(t) = L_2 \frac{di_2}{dt} + M \frac{di_1}{dt} \Rightarrow V_2(s) = s(I_1(s) - 2) + 2(s I_2(s) - 3) = s I_1(s) + 2s I_2(s) - 8$$

Writing mesh equations:

$$\frac{5}{s} = 2(I_1(s) + I_2(s)) + V_1 = 2(I_1(s) + I_2(s)) + 3s I_1(s) + s I_2(s) - 9 \Rightarrow (3s + 2)I_1 + (s + 2)I_2 = 9 + \frac{5}{s}$$

$$V_1(s) = V_2(s) + 1I_2(s) \Rightarrow 3s I_1(s) + s I_2(s) - 9 = s I_1(s) + 2s I_2(s) - 8 + I_2(s) \Rightarrow 2s I_1 - (s + 1)I_2 = 1$$

Solving the mesh equations for $I_2(s)$:

$$I_2(s) = \frac{15s + 8}{5s^2 + 9s + 2} = \frac{3s + 1.6}{(s + 0.26)(s + 1.54)} = \frac{0.64}{s + 0.26} + \frac{2.36}{s + 1.54}$$

Taking the inverse Laplace transform:

$$i_2(t) = 0.64e^{-0.26t} + 2.36e^{-1.54t} \text{ A for } t > 0$$

P14.8-8

$t < 0$

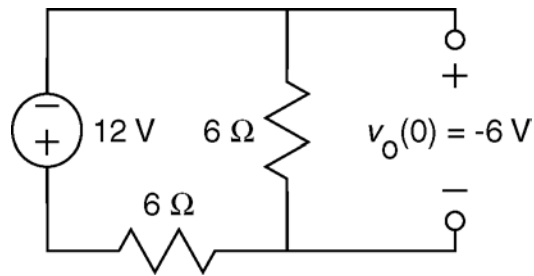

time domain

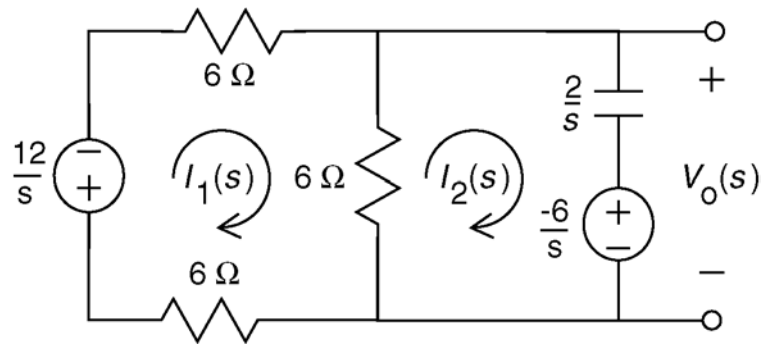

frequency domain

Mesh equations in the frequency domain:

$$6I_1(s) + 6(I_1(s) - I_2(s)) + 6I_1(s) + \frac{12}{s} = 0 \Rightarrow I_1(s) = \frac{2}{3}I_2(s) - \frac{2}{3s}$$

$$\frac{2}{s}I_2(s) - \frac{6}{s} - 6(I_1(s) - I_2(s)) = 0 \Rightarrow \left(6 + \frac{2}{s}\right)I_2(s) - 6I_1(s) = \frac{6}{s}$$

Solving for $I_2(s)$:

$$\left(6 + \frac{2}{s}\right)I_2(s) - 6\left(\frac{2}{3}I_2(s) - \frac{2}{3s}\right) = \frac{6}{s} \Rightarrow I_2(s) = \frac{\frac{1}{2}}{s + \frac{1}{2}}$$

Calculate for $V_o(s)$:

$$V_o(s) = \frac{1}{2}I_2(s) - \frac{6}{s} = \frac{1}{2}\left(\frac{\frac{1}{2}}{s + \frac{1}{2}}\right) - \frac{6}{s} = \frac{-2}{s + \frac{1}{2}} - \frac{4}{s}$$

Take the Inverse Laplace transform:

$$v_o(t) = -(4 + 2e^{-t/2}) \text{ V for } t > 0$$

(Checked using LNAP, 12/29/02)

P14.8-9

$t < 0$

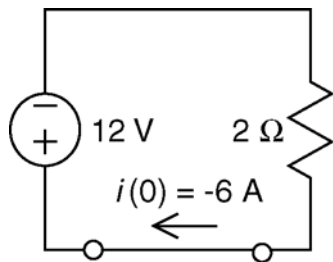

time domain

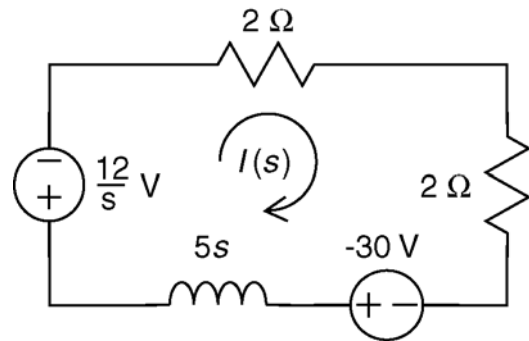

frequency domain

Writing a mesh equation:

$$(4 + 5s)I(s) + 30 + \frac{12}{s} = 0 \Rightarrow I(s) = \frac{-6\left(s + \frac{2}{5}\right)}{s\left(s + \frac{4}{5}\right)} = -\left(\frac{3}{s} + \frac{3}{s + \frac{4}{5}}\right)$$

Take the Inverse Laplace transform:

$$i(t) = -3(1 + e^{-0.8t}) \text{ A for } t > 0$$

(Checked using LNAP, 12/29/02)

P14.8-10

Steady-state for $t < 0$:

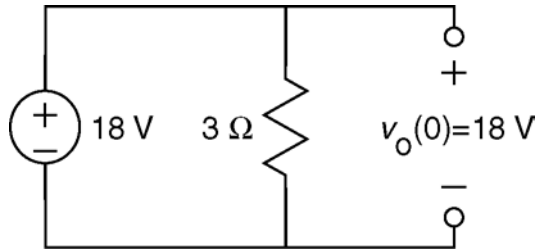

From the equation for $v_o(t)$:

$$v_o(\infty) = 6 + 12e^{-2(\infty)} = 6 \text{ V}$$

From the circuit:

$$v_o(\infty) = \frac{3}{R+3}(18)$$

Therefore:

$$6 = \frac{3}{R+3}(18) \Rightarrow \underline{R = 6 \Omega}$$

Steady-state for $t > 0$:

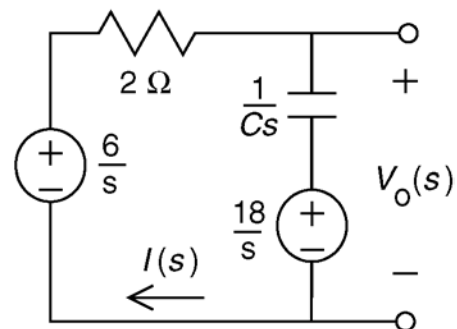
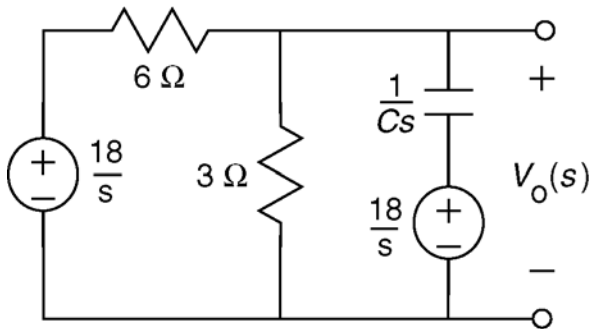
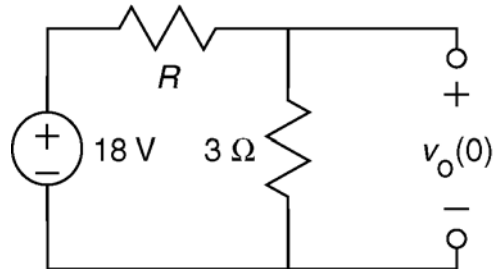

$$I(s) \left(2 + \frac{1}{Cs} \right) + \frac{18}{s} - \frac{6}{s} = 0 \Rightarrow I(s) = \frac{-6}{s + \frac{1}{2C}}$$

$$V_o(s) = \frac{1}{Cs} I(s) + \frac{18}{s} = \frac{1}{Cs} \left(\frac{-6}{s + \frac{1}{2C}} \right) + \frac{18}{s} = \frac{-12}{s} + \frac{12}{s + \frac{1}{2C}} + \frac{18}{s} = \frac{12}{s + \frac{1}{2C}} + \frac{6}{s}$$

Taking the inverse Laplace transform:

$$v_o(t) = 6 + 12e^{-t/2C} \text{ V for } t > 0$$

Comparing this to the given equation for $v_o(t)$, we see that $2 = \frac{1}{2C} \Rightarrow \underline{C = 0.25 \text{ F}}$.

(Checked using LNAP, 12/29/02)

Section 14-9: Transfer Function and Impedance

P14.9-1

$$H(s) = \frac{Z_2}{Z_1 + Z_2} \quad \text{where} \quad Z_1 = \frac{\frac{R_1}{C_1 s}}{R_1 + \frac{R_1}{C_1 s}} = \frac{R_1}{R_1 C_1 s + 1} \quad \text{and} \quad Z_2 = \frac{R_2}{R_2 C_2 s + 1}$$

$$\text{Let } \tau_1 = R_1 C_1 \text{ and } \tau_2 = R_2 C_2 \text{ then } H(s) = \frac{R_2(\tau_1 s + 1)}{R_1(\tau_2 s + 1) + (\tau_1 s + 1) R_2}$$

$$\text{When } \tau_2 = \tau_1 = \tau \Rightarrow H(s) = \frac{R_2(\tau s + 1)}{(R_1 + R_2)(\tau s + 1)} = \frac{R_2}{R_1 + R_2} = \text{constant, as required.}$$

\therefore we require $\underline{R_1 C_1 = R_2 C_2}$

P14.9-2

Let $Z_1 = R + \frac{1}{Cs}$ and $Z_2 = R + Ls$ then the input impedance is

$$Z(s) = \frac{Z_1 Z_2}{Z_1 + Z_2} = \frac{\left(R + \frac{1}{Cs}\right)(R + Ls)}{R + \frac{1}{Cs} + R + Ls} = R \left(\frac{LCs^2 + \left(RC + \frac{L}{R}\right)s + 1}{LCs^2 + 2RCs + 1} \right)$$

Now require : $RC + \frac{L}{R} = 2RC \Rightarrow \underline{L = R^2 C}$ then $\underline{Z = R}$

P14.9-3

The transfer function is

$$H(s) = \frac{\frac{R_2}{R_2 C s + 1}}{R_1 + \frac{R_2}{R_2 C s + 1}} = \frac{\frac{1}{R_1 C}}{s + \frac{R_1 + R_2}{R_1 R_2 C}}$$

Using $R_1 = 2 \Omega$, $R_2 = 8 \Omega$ and $C = 5 \text{ F}$ gives

$$H(s) = \frac{0.1}{s + 0.125}$$

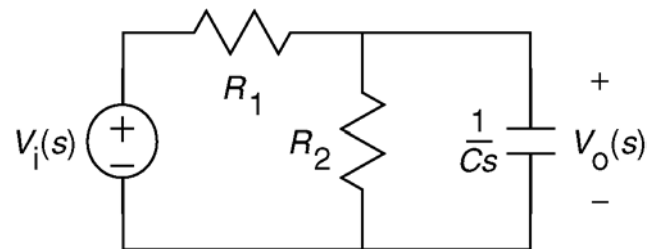

The impulse response is $h(t) = \mathcal{L}^{-1}[H(s)] = 0.1 e^{-0.125t} u(t) \text{ V}$.

The step response is

$$\mathcal{L}^{-1}\left[\frac{H(s)}{s}\right] = \mathcal{L}^{-1}\left[\frac{0.1}{s(s+0.125)}\right] = \mathcal{L}^{-1}\left[\frac{0.8}{s} - \frac{0.8}{s+0.125}\right] = 0.8(1 - e^{-0.125t})u(t) \text{ V}$$

(Checked using LNAP, 12/29/02)

P14.9-4

The transfer function is:

$$H(s) = \mathcal{L}[12te^{-4t}u(t)] = \frac{12}{(s+4)^2} = \frac{12}{s^2+8s+16}$$

The Laplace transform of the step response is:

$$\frac{H(s)}{s} = \frac{12}{s(s+4)^2} = \frac{\frac{3}{4}}{s} + \frac{-3}{(s+4)^2} + \frac{k}{s+4}$$

The constant k is evaluated by multiplying both sides of the last equation by $s(s+4)^2$.

$$12 = \frac{3}{4}(s+4)^2 - 3s + ks(s+4) = \left(\frac{3}{4} + k\right)s^2 + (3+4k)s + 12 \Rightarrow k = -\frac{3}{4}$$

The step response is

$$\mathcal{L}^{-1}\left[\frac{H(s)}{s}\right] = \left(\frac{3}{4} - e^{-4t}\left(3t + \frac{3}{4}\right)\right)u(t) \text{ V}$$

P14.9-5

The transfer function can also be calculated from the circuit itself. The circuit can be represented in the frequency domain as

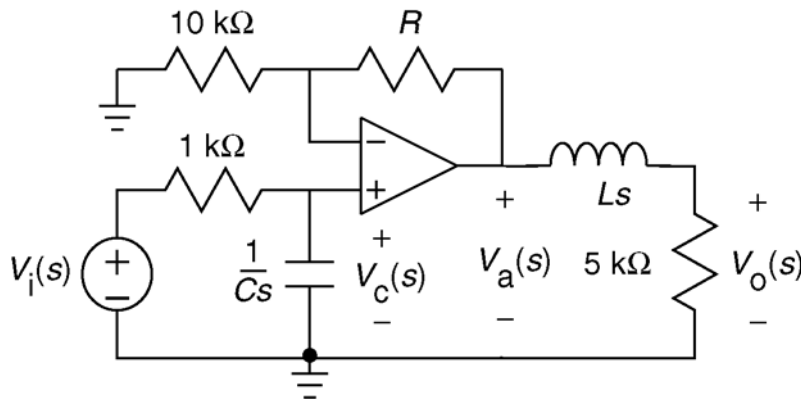

We can save ourselves some work by noticing that the 10000 ohm resistor, the resistor labeled R and the op amp comprise a non-inverting amplifier. Thus

$$V_a(s) = \left(1 + \frac{R}{10000}\right)V_c(s)$$

Now, writing node equations,

$$\frac{V_c(s) - V_i(s)}{1000} + CsV_c(s) = 0 \quad \text{and} \quad \frac{V_o(s) - V_a(s)}{Ls} + \frac{V_o(s)}{5000} = 0$$

Solving these node equations gives

$$H(s) = \frac{\frac{1}{1000C} \left(1 + \frac{R}{10000}\right) \frac{5000}{L}}{\left(s + \frac{1}{1000C}\right) \left(s + \frac{5000}{L}\right)}$$

Comparing these two equations for the transfer function gives

$$\left(s + \frac{1}{1000C}\right) = (s + 2000) \quad \text{or} \quad \left(s + \frac{1}{1000C}\right) = (s + 5000)$$

$$\left(s + \frac{5000}{L}\right) = (s + 2000) \quad \text{or} \quad \left(s + \frac{5000}{L}\right) = (s + 5000)$$

$$\frac{1}{1000C} \left(1 + \frac{R}{10000}\right) \frac{5000}{L} = 15 \times 10^6$$

The solution isn't unique, but there are only two possibilities. One of these possibilities is

$$\left(s + \frac{1}{1000C}\right) = (s + 2000) \Rightarrow C = 0.5 \mu\text{F}$$

$$\left(s + \frac{5000}{L}\right) = (s + 5000) \Rightarrow L = 1 \text{ H}$$

$$\frac{1}{1000(0.5 \times 10^6)} \left(1 + \frac{R}{10000}\right) \frac{5000}{1} = 15 \times 10^6 \Rightarrow R = 5 \text{ k}\Omega$$

(Checked using LNAP, 12/29/02)

P14.9-6

The transfer function of the circuit is

$$H(s) = -\frac{\frac{R_2}{1 + R_2 C s}}{R_1} = -\frac{\frac{1}{R_1 C}}{s + \frac{1}{R_2 C}}$$

The give step response is $v_o(t) = -4(1 - e^{-250t})u(t)$ V. The correspond transfer function is calculated as

$$\frac{H(s)}{s} = \mathcal{L}\{-4(1 - e^{-250t})u(t)\} = -\left(\frac{4}{s} - \frac{4}{s + 250}\right) = \frac{-1000}{s(s + 250)} \Rightarrow H(s) = \frac{-1000}{s + 250}$$

Comparing these results gives

$$\frac{1}{R_2 C} = 250 \Rightarrow R_2 = \frac{1}{250 C} = \frac{1}{250(0.1 \times 10^{-6})} = 40 \text{ k}\Omega$$

$$\frac{1}{R_1 C} = 1000 \Rightarrow R_1 = \frac{1}{1000 C} = \frac{1}{1000(0.1 \times 10^{-6})} = 10 \text{ k}\Omega$$

(Checked using LNAP, 12/29/02)

P14.9-7

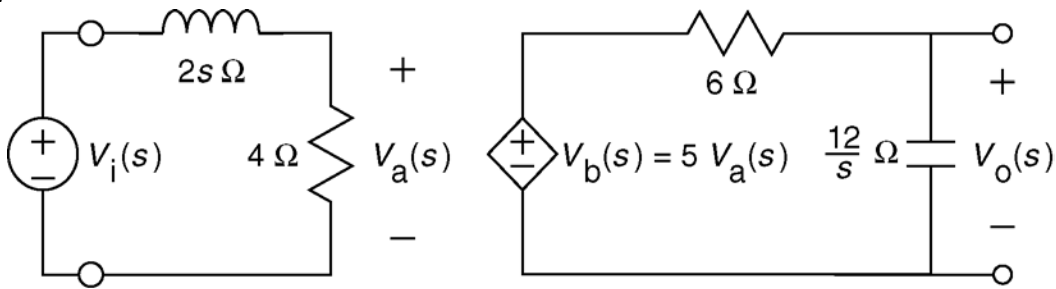

$$V_a(s) = \left(\frac{4}{4 + 2s}\right)V_i(s) = \left(\frac{2}{s + 2}\right)V_i(s)$$

$$V_o(s) = \left(\frac{\frac{12}{s}}{6 + \frac{12}{s}}\right)V_b(s) = \left(\frac{2}{s + 2}\right)V_b(s) = \left(\frac{2}{s + 2}\right)5V_a(s) = \left(\frac{2}{s + 2}\right)5\left(\frac{2}{s + 2}\right)V_i(s)$$

The transfer function is:

$$H(s) = \frac{V_o(s)}{V_i(s)} = \frac{20}{(s + 2)^2}$$

The Laplace transform of the step response is:

$$V_o(s) = \frac{20}{s(s+2)^2} = \frac{5}{s} + \frac{-5}{s+2} + \frac{-10}{(s+2)^2}$$

Taking the inverse Laplace transform:

$$v_o(t) = [5 - 5e^{-2t}(1+2t)]u(t) \text{ V}$$

(checked using LNAP 8/15/02)

P 14.9-8

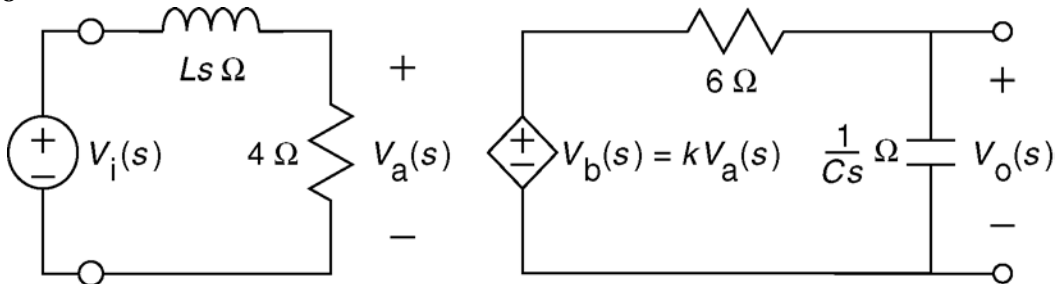

From the circuit:

$$H(s) = \left(\frac{4}{4+Ls} \right) (k) \left(\frac{\frac{1}{Cs}}{6+\frac{1}{Cs}} \right) = \left(\frac{\frac{4}{L}}{s+\frac{4}{L}} \right) (k) \left(\frac{\frac{1}{6C}}{s+\frac{1}{6C}} \right)$$

From the given step response:

$$\frac{H(s)}{s} = \mathcal{L}[(2+4e^{-3t}-6e^{-2t})u(t)] = \frac{2}{s} + \frac{4}{s+3} - \frac{6}{s+2} = \frac{12}{s(s+3)(s+2)}$$

so

$$H(s) = \frac{12}{s(s+3)(s+2)}$$

Comparing the two representations of the transfer functions let $\frac{1}{6C} = 3 \Rightarrow C = \frac{1}{18} \text{ F}$,

$\frac{4}{L} = 2 \Rightarrow L = 2 \text{ H}$ and $2 \times 3 \times k = 12 \Rightarrow k = 2 \text{ V/V}$.

(Checked using LNAP, 12/29/02)

P 14.9.9

From the circuit:

$$H(s) = \frac{V_o(s)}{V_i(s)} = \frac{R + Ls}{12 + R + Ls} = \frac{s + \frac{R}{L}}{s + \frac{12 + R}{L}}$$

From the given step response:

$$\frac{H(s)}{s} = \mathcal{L}[0.5(1 + e^{-4t})u(t)] = \frac{0.5}{s} + \frac{0.5}{s + 4} = \frac{s + 2}{s(s + 4)} \Rightarrow H(s) = \frac{s + 2}{s + 4}$$

Comparing these two forms of the transfer function gives:

$$\left. \begin{array}{l} \frac{R}{L} = 2 \\ \frac{12 + R}{L} = 4 \end{array} \right\} \Rightarrow \frac{12 + 2L}{L} = 4 \Rightarrow L = 6 \text{ H}, R = 12 \text{ } \Omega$$

(Checked using LNAP, 12/29/02)

P14.9-10

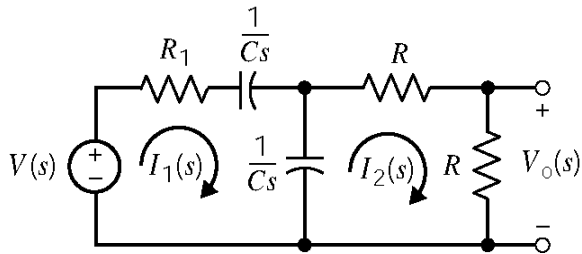

Mesh equations:

$$V(s) = \left(R_1 + \frac{1}{Cs} + \frac{1}{Cs} \right) I_1(s) - \frac{1}{Cs} I_2(s)$$

$$0 = \left(R + R + \frac{1}{Cs} \right) I_2(s) - \frac{1}{Cs} I_1(s)$$

Solving for $I_2(s)$:

$$I_2(s) = \frac{V(s) \left(\frac{1}{Cs} \right)}{\left(R_1 + \frac{2}{Cs} \right) \left(2R + \frac{1}{Cs} \right) - \frac{1}{(Cs)^2}}$$

Then $V_o(s) = RI_2(s)$ gives

$$H(s) = \frac{V_o(s)}{V(s)} = \frac{RCs}{[R_1Cs + 2][2RCs + 1] - 1} = \frac{s}{2R_1C \left[s^2 + \frac{4RC + R_1C}{2RR_1C^2} s + \frac{1}{(2RR_1C^2)^2} \right]}$$

P14.9-11

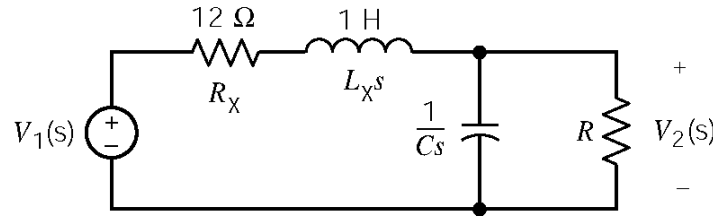

Let

$$Z_2 = \frac{R \left(\frac{1}{Cs} \right)}{R + \frac{1}{Cs}} = \frac{R}{RCs + 1}$$

$$Z_1 = R_x + L_x s$$

Then

$$\frac{V_2}{V_1} = \frac{Z_2}{Z_1 + Z_2} = \frac{\frac{R}{RCs + 1}}{R_x + L_x s + \frac{R}{RCs + 1}} = \frac{R}{L_x RCs^2 + (L_x + R_x RC)s + R_x + R}$$

$$\frac{V_2}{V_1} = \frac{\frac{1}{LC}}{s^2 + \frac{(L_x + R_x RC)}{L_x RC} s + \frac{R_x + R}{L_x RC}}$$

P14.9-12

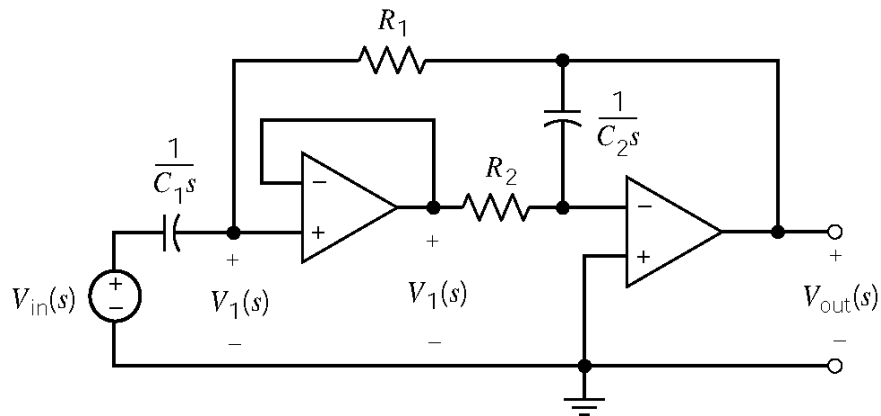

Node equations:

$$(V_1 - V_{in})sC_1 + \frac{V_1 - V_{out}}{R_1} = 0 \Rightarrow (R_1 C_1 s + 1)V_1 = R_1 C_1 s V_{in} + V_{out}$$

$$\frac{V_1}{R_2} + V_{out} + sC_2 = 0 \Rightarrow V_1 = -R_2 C_2 s V_{out}$$

Solving gives:

$$H(s) = \frac{V_{out}}{V_{in}} = \frac{-R_1 C_1 s}{R_1 R_2 C_1 C_2 s^2 + R_2 C_2 s + 1} = \frac{-\frac{1}{R_2 C_2} s}{s^2 + \frac{1}{R_1 C_1} s + \frac{1}{R_1 R_2 C_1 C_2}}$$

P14.9-13

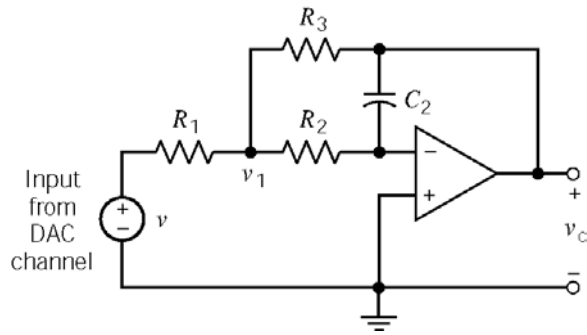

Node equations in the frequency domain:

$$\frac{V_1 - V_i}{R_1} + \frac{V_1 - V_2}{R_2} + \frac{V_1 - V_0}{R_3} = 0$$

$$\Rightarrow V_1 \left(\frac{1}{R_1} + \frac{1}{R_2} + \frac{1}{R_3} \right) - \frac{V_0}{R_3} = \frac{V_i}{R_1}$$

$$\frac{V_2 - V_1}{R_2} - sC_2 V_0 = 0 \Rightarrow V_1 = -sC_2 R_2 V_0$$

After a little algebra:

$$H(s) = \frac{V_0}{V_i} = \frac{-R_3}{sC_2 R_2 R_3 + sC_2 R_1 R_3 + sC_2 R_1 R_2 + R_1}$$

P14.9-14

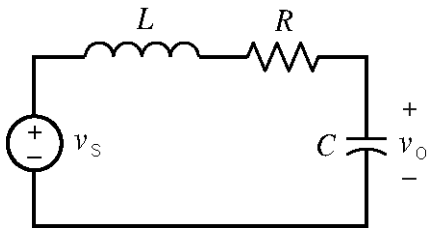

$$H(s) = \frac{V_o(s)}{V_i(s)} = \frac{\frac{1}{Cs}}{Ls + R + \frac{1}{Cs}} = \frac{\frac{1}{LC}}{s^2 + \frac{R}{L}s + \frac{1}{LC}}$$

L, H	C, F	R, Ω	$H(s)$
2	0.025	18	$\frac{20}{s^2 + 9s + 20} = \frac{20}{(s+4)(s+5)}$
2	0.025	8	$\frac{20}{s^2 + 4s + 20} = \frac{20}{(s+2)^2 + 4^2}$
1	0.391	4	$\frac{2.56}{s^2 + 4s + 2.56} = \frac{2.56}{(s+0.8)(s+3.2)}$
2	0.125	8	$\frac{20}{s^2 + 4s + 4} = \frac{20}{(s+2)^2}$

$$\text{a) } H(s) = \frac{20}{(s+4)(s+5)} \quad \mathcal{L}\{h(t)\} = H(s) = \frac{20}{s+4} - \frac{20}{s+5} \Rightarrow h(t) = (20e^{-4t} - 20e^{-5t})u(t)$$

$$\mathcal{L}\{\text{step response}\} = \frac{H(s)}{s} = \frac{20}{s(s+4)(s+5)} = \frac{1}{s} + \frac{-5}{s+4} + \frac{4}{s+5} \Rightarrow$$

$$\text{step response} = (1 + 4e^{-5t} - 5e^{-4t})u(t)$$

$$\text{b) } H(s) = \frac{20}{(s+2)^2 + 4^2} \quad \mathcal{L}\{h(t)\} = H(s) = \frac{5(4)}{(s+2)^2 + 4^2} \Rightarrow h(t) = 5e^{-2t} \sin 4t u(t)$$

$$\mathcal{L}\{\text{step response}\} = \frac{H(s)}{s} = \frac{20}{s(s^2 + 4s + 20)} = \frac{1}{s} + \frac{K_1s + K_2}{s^2 + 4s + 20}$$

$$20 = s^2 + 4s + 20 + s(K_1s + K_2) = s^2(1 + K_1) + s(4 + K_2) + 20$$

$$\Rightarrow K_1 = -1, K_2 = -4$$

$$\mathcal{L}\{\text{step response}\} = \frac{1}{s} + \frac{-(s+2)}{(s+2)^2 + 4^2} + \frac{-\frac{1}{2}(4)}{(s+2) + 4^2}$$

$$\text{step response} = \left(1 - e^{-2t} \left(\cos 4t + \frac{1}{2} \sin 4t\right)\right)u(t)$$

$$\text{c) } H(s) = \frac{2.56}{(s+0.8)(s+3.2)} \quad \mathcal{L}\{h(t)\} = H(s) = \frac{1.07}{s+.8} - \frac{1.07}{s+3.2} \Rightarrow h(t) = 1.07(e^{-.8t} - e^{-3.2t})u(t)$$

$$\mathcal{L}\{\text{step response}\} = \frac{H(s)}{s} = \frac{2.56}{s(s+.8)(s+3.2)} = \frac{1}{s} + \frac{-\frac{4}{3}}{s+.8} + \frac{\frac{1}{3}}{s+3.2}$$

$$\text{step response} = \left(1 + \frac{1}{3}e^{-3.2t} - \frac{4}{3}e^{-.8t}\right)u(t)$$

$$\text{d) } H(s) = \frac{20}{(s+2)^2} \quad h(t) = 4te^{-2t}u(t)$$

$$\text{step response} = (1 - (1+2t)e^{-2t})u(t)$$

P14.9-15

For an impulse response, take $V_1(s) = 1$. Then

$$V_0(s) = \frac{3(s+2)}{s(s+3-j2)(s+3+j2)} = \frac{A}{s} + \frac{B}{s+3-j2} + \frac{B^*}{s+3+j2}$$

Where

$$A = sV_0(s)\Big|_{s=0} = 0.462, \quad B = (s+3-j2)V_0(s)\Big|_{s=3-j2} = 0.47\angle -119.7^\circ \quad \text{and} \quad B^* = 0.47\angle 119.7^\circ$$

Then

$$V_0(s) = \frac{0.462}{s} + \frac{0.47\angle -119.7^\circ}{s+3-j2} + \frac{0.47\angle 119.7^\circ}{s+3+j2}$$

The impulse response is

$$v_0(t) = \left[0.462 + 2(0.47)e^{-3t} \cos(2t - 119.7^\circ) \right] u(t) \quad \text{V}$$

Section 14-10: Convolution Theorem**P14.10-1**

$$f(t) = u(t) - u(t-1) \Rightarrow F(s) = \mathcal{L}[u(t) - u(t-1)] = \frac{1}{s} - \frac{e^{-s}}{s} = \frac{1 - e^{-s}}{s}$$

$$\begin{aligned} f(t) * f(t) &= \mathcal{L}^{-1}[F^2(s)] = \mathcal{L}^{-1}\left[\left(\frac{1 - e^{-s}}{s}\right)^2\right] = \mathcal{L}^{-1}\left[\frac{1 - 2e^{-s} + e^{-2s}}{s^2}\right] \\ &= tu(t) - 2(t-1)u(t-1) + (t-2)u(t-2) \end{aligned}$$

P14.10-2

$$f(t) = 2[u(t) - u(t-2)] \Rightarrow F(s) = \frac{2}{s} - \frac{2e^{-2s}}{s}$$

$$f * f = \mathcal{L}^{-1}[F(s)F(s)] = \mathcal{L}^{-1}\left[\frac{4}{s^2} - \frac{8e^{-2s}}{s^2} + \frac{4e^{-4s}}{s^2}\right] = 4tu(t) - 8(t-2)u(t-2) + 4(t-4)u(t-4)$$

P14.10-3

$$v_1(t) = tu(t) \Rightarrow V_1(s) = \frac{1}{s^2}$$

$$H(s) = \frac{V_2(s)}{V_1(s)} = \frac{\frac{1}{Cs}}{R + \frac{1}{Cs}} = \frac{\frac{1}{RC}}{s + \frac{1}{RC}}$$

$$v_2(t) = h(t) * v_1(t) = \mathcal{L}^{-1} [V_1(s) H(s)]$$

$$V_2(s) = V_1(s) H(s) = \left(\frac{1}{s^2}\right) \left(\frac{\frac{1}{RC}}{s + \frac{1}{RC}}\right)$$

$$\underline{v_2(t) = t - RC(1 - e^{-t/RC}), t \geq 0}$$

P14.10-4

$$h(t) * f(t) = \mathcal{L}^{-1} [H(s) F(s)] \text{ where } H(s) = \frac{1}{s^2} \text{ and } F(s) = \frac{1}{s+a}$$

$$\text{So } H(s) F(s) = \left(\frac{1}{s^2}\right) \left(\frac{1}{s+a}\right) = \frac{A}{s} + \frac{B}{s^2} + \frac{C}{s+a}$$

Solving the partial fractions yields: $A = -1/a^2$, $B = 1/a$, $C = 1/a^2$

$$\underline{\text{So } h(t) * f(t) = \frac{-1}{a^2} + \frac{t}{a} + \frac{e^{-at}}{a^2}, \quad t \geq 0}$$

Section 14-11: Stability

P14.11-1

a. From the given step response:

$$\frac{H(s)}{s} = \mathcal{L}\left[\frac{3}{4}(1 - e^{-100t})u(t)\right] = \frac{75}{s(s+100)}$$

From the circuit:

$$H(s) = \frac{R}{R+5+Ls} \Rightarrow \frac{H(s)}{s} = \frac{\frac{R}{L}}{s\left(s + \frac{R+5}{L}\right)}$$

Comparing gives

$$\left. \begin{array}{l} \frac{R}{L} = 75 \\ \frac{R+5}{L} = 100 \end{array} \right\} \Rightarrow \begin{array}{l} R = 15 \Omega \\ L = 0.2 \text{ H} \end{array}$$

b. The impulse response is

$$h(t) = \mathcal{L}^{-1}\left[\frac{75}{s+100}\right] = 75 e^{-100t} u(t)$$

c.

$$\begin{aligned} \mathbf{H}(\omega)\big|_{\omega=100} &= \frac{75}{j100+100} = \frac{3}{4\sqrt{2}} \angle 45^\circ \\ \mathbf{V}_o(\omega) &= \left(\frac{3}{4\sqrt{2}} \angle 45^\circ\right)(5 \angle 0^\circ) = \frac{15}{4\sqrt{2}} \angle 45^\circ \text{ V} \\ v_o(t) &= 2.652 \cos(100t - 45^\circ) \text{ V} \end{aligned}$$

(Checked using LNAP, 12/29/02)

P14.11-2

The transfer function of this circuit is given by

$$\frac{H(s)}{s} = \mathcal{L}\left[(5 - 5e^{-2t}(1+2t))u(t)\right] = \frac{5}{s} + \frac{-5}{s+2} + \frac{-10}{(s+2)^2} = \frac{20}{(s+2)^2} \Rightarrow H(s) = \frac{20}{s(s+2)^2}$$

This transfer function is stable so we can determine the network function as

$$\mathbf{H}(\omega) = H(s)\big|_{s=j\omega} = \frac{20}{(s+2)^2}\bigg|_{s=j\omega} = \frac{20}{(2+j\omega)^2}$$

The phasor of the output is

$$\mathbf{V}_o(\omega) = \frac{20}{(2 + j2)^2} (5 \angle 45^\circ) = \frac{20}{(2\sqrt{2} \angle 45^\circ)^2} (5 \angle 45^\circ) = 12.5 \angle -45^\circ \text{ V}$$

The steady-state response is

$$v_o(t) = 12.5 \cos(2t - 45^\circ) \text{ V}$$

(Checked using LNAP, 12/29/02)

P 14.11-3

The transfer function of the circuit is $H(s) = \mathcal{L}^{-1}[30t e^{-5t} u(t)] = \frac{30}{(s+5)^2}$. The circuit is stable so we can determine the network function as

$$\mathbf{H}(\omega) = H(s) \Big|_{s=j\omega} = \frac{30}{(s+5)^2} \Big|_{s=j\omega} = \frac{30}{(5+j\omega)^2}$$

The phasor of the output is

$$\mathbf{V}_o(\omega) = \frac{30}{(5+j3)^2} (10 \angle 0^\circ) = \frac{30}{(5.83 \angle 31^\circ)^2} (10 \angle 0^\circ) = 8.82 \angle -62^\circ \text{ V}$$

The steady-state response is

$$v_o(t) = 8.82 \cos(3t - 62^\circ) \text{ V}$$

PSpice Problems

SP 14-1

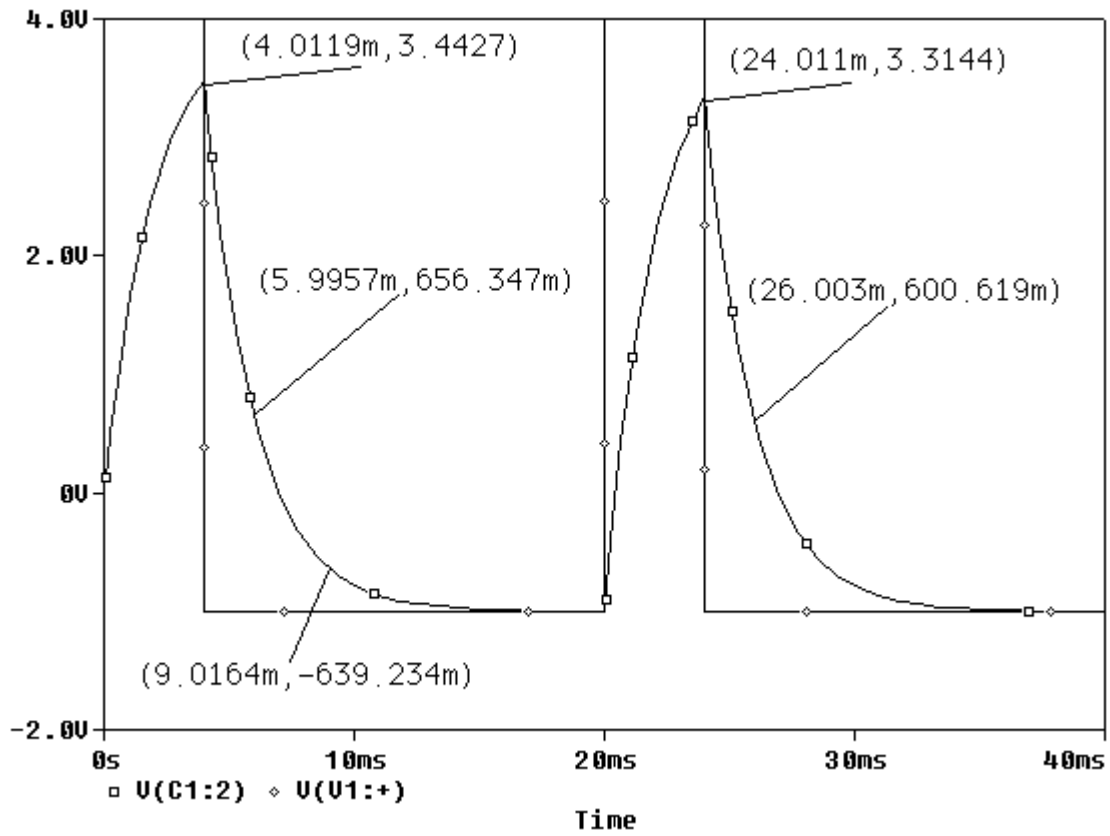
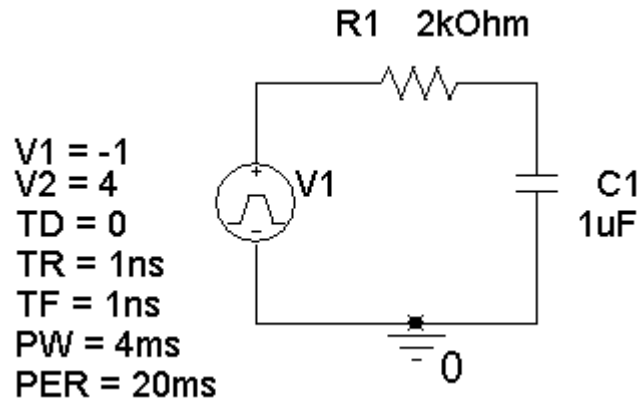

SP 14-2

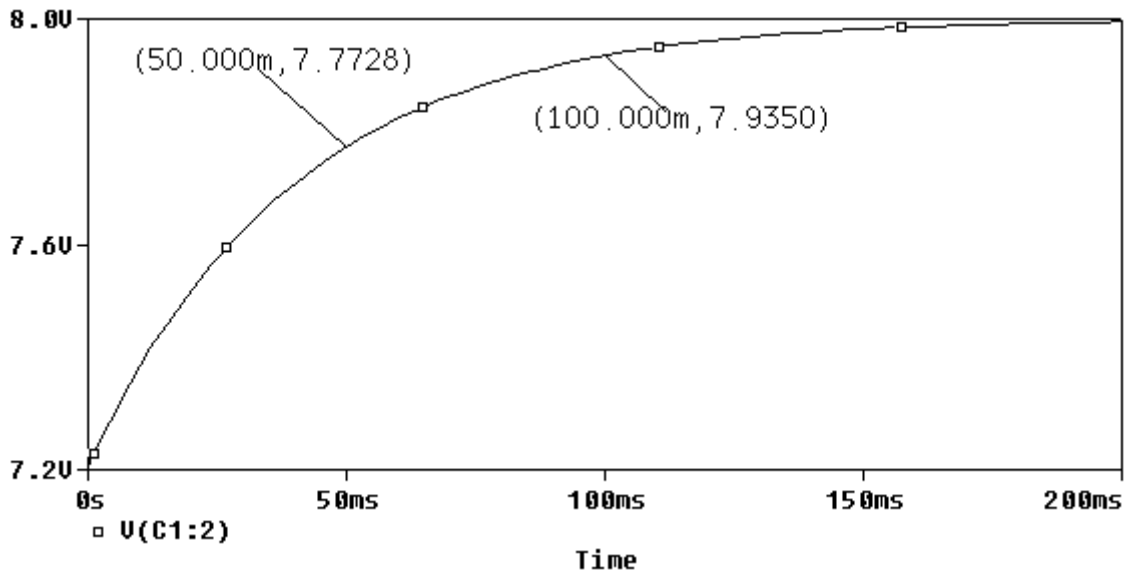
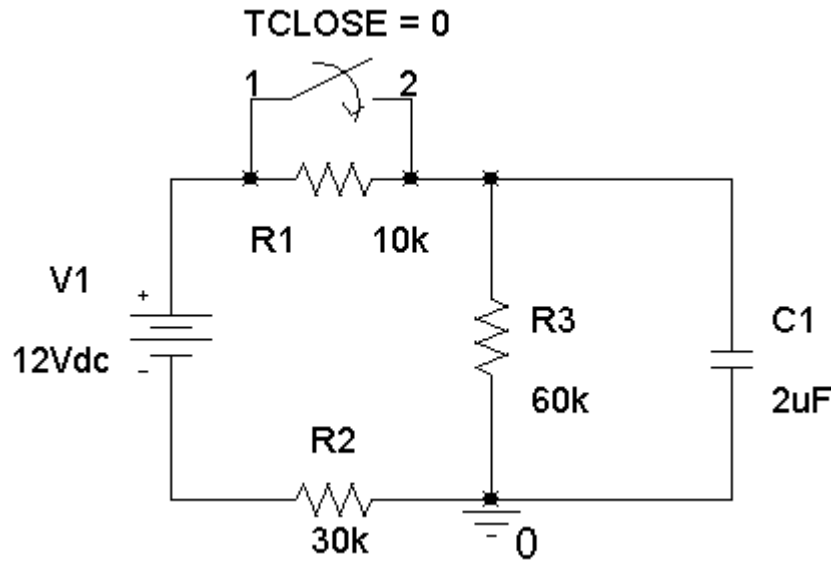

$$v(t) = A + B e^{-t/\tau} \quad \text{for } t > 0$$

$$\left. \begin{aligned} 7.2 = v(0) = A + B e^0 &\Rightarrow 7.2 = A + B \\ 8.0 = v(\infty) = A + B e^{-\infty} &\Rightarrow A = 8.0 \text{ V} \end{aligned} \right\} \Rightarrow B = -0.8 \text{ V}$$

$$7.7728 = v(0.05) = 8 - 0.8 e^{-0.05/\tau} \Rightarrow -\frac{0.05}{\tau} = \ln\left(\frac{8 - 7.7728}{0.8}\right) = -1.25878$$

$$\Rightarrow \tau = \frac{0.05}{1.25878} = 39.72 \text{ ms}$$

Therefore

$$v(t) = 8 - 0.8 e^{-t/0.03972} \quad \text{for } t > 0$$

SP 14-3

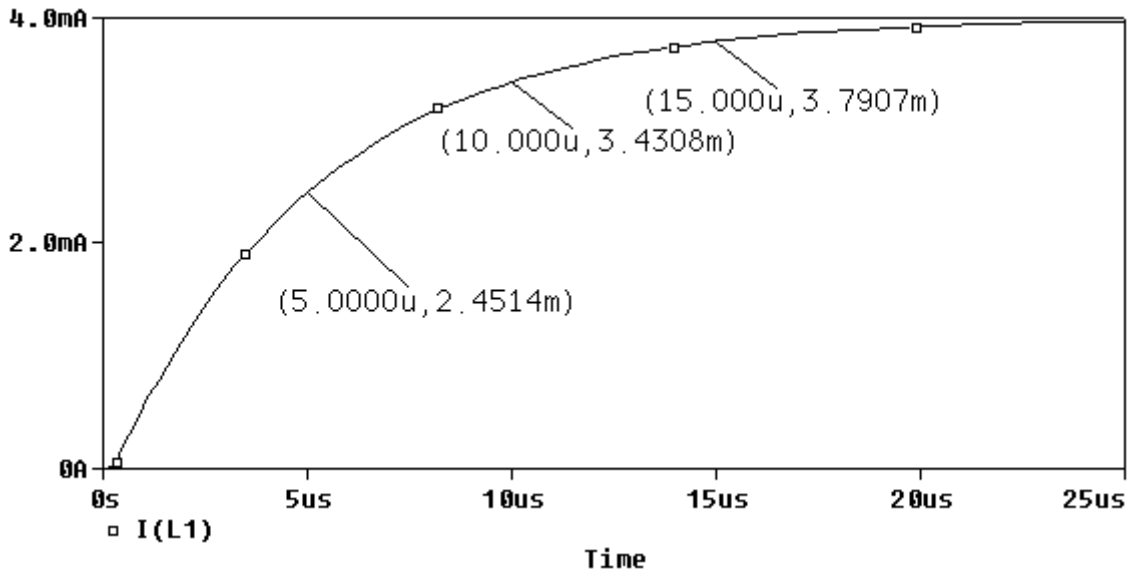
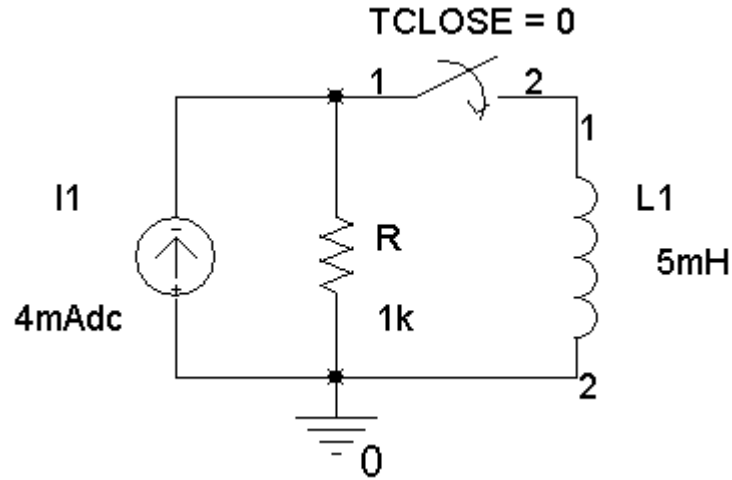

$$i(t) = A + B e^{-t/\tau} \quad \text{for } t > 0$$

$$\left. \begin{aligned} 0 = i(0) = A + B e^0 &\Rightarrow 0 = A + B \\ 4 \times 10^{-3} = i(\infty) = A + B e^{-\infty} &\Rightarrow A = 4 \times 10^{-3} \text{ A} \end{aligned} \right\} \Rightarrow B = -4 \times 10^{-3} \text{ A}$$

$$2.4514 \times 10^{-3} = i(5 \times 10^{-6}) = (4 \times 10^{-3}) - (4 \times 10^{-3}) e^{-(5 \times 10^{-6})/\tau}$$

$$\Rightarrow -\frac{5 \times 10^{-6}}{\tau} = \ln\left(\frac{(4 - 2.4514) \times 10^{-3}}{4 \times 10^{-3}}\right) = -0.94894$$

$$\Rightarrow \tau = \frac{5 \times 10^{-6}}{0.94894} = 5.269 \mu\text{s}$$

Therefore

$$i(t) = 4 - 4 e^{-t/5.269 \times 10^{-6}} \quad \text{for } t > 0$$

SP 14-4

Make three copies of the circuit: one for each set of parameter values. (Cut and paste, but be sure to edit the labels of the parts so, for example, there is only one R1.)

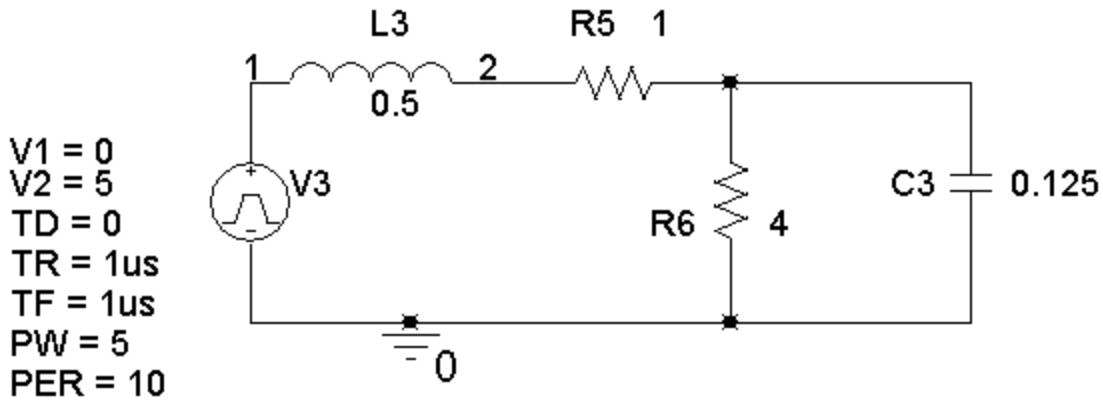
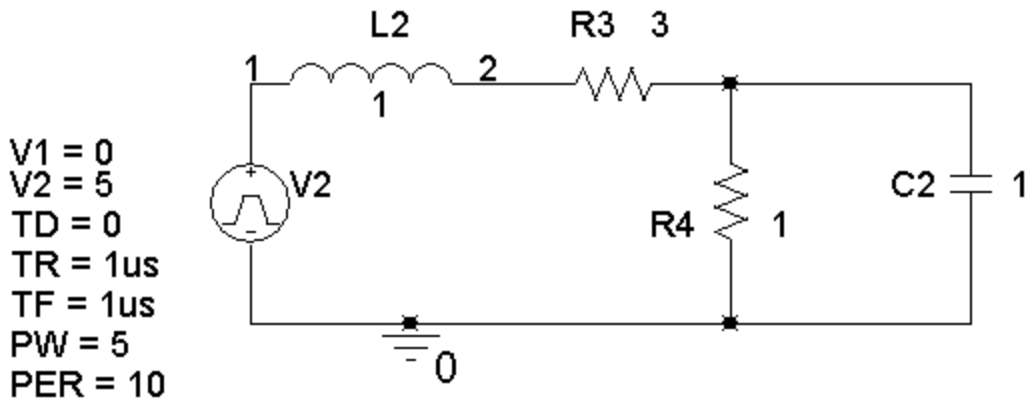
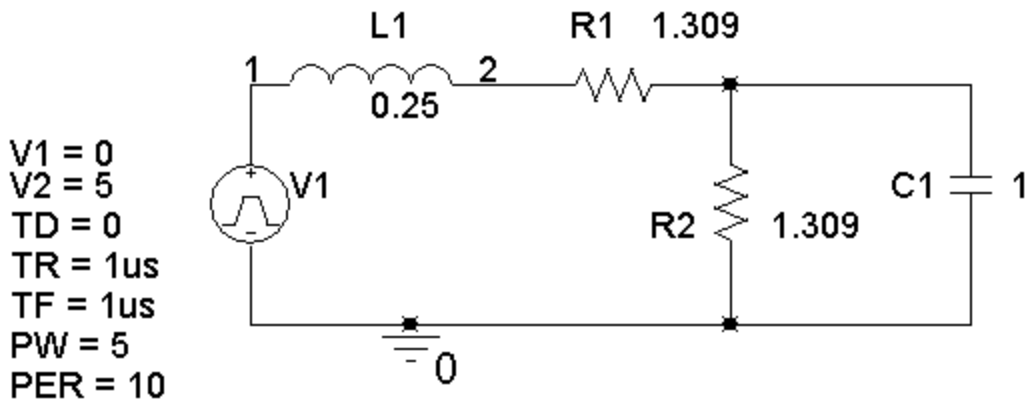

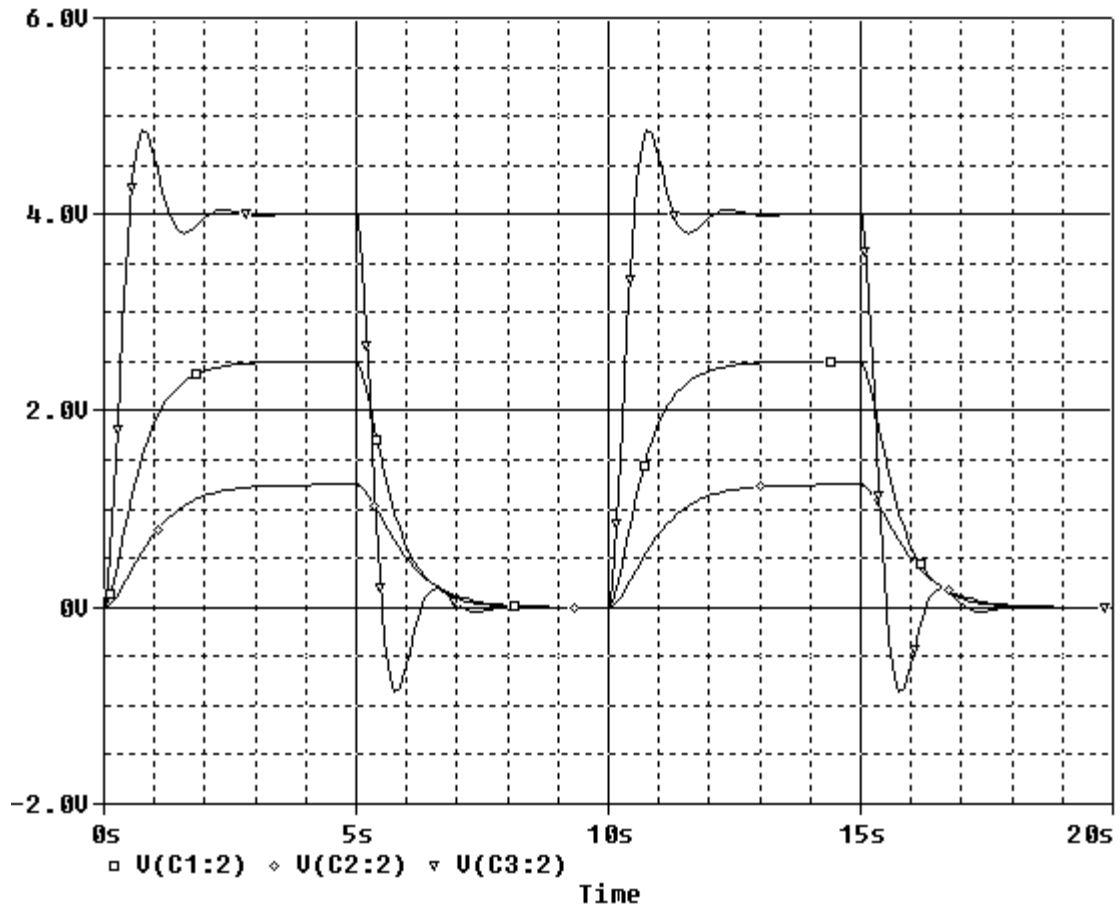

$V(C1:2)$, $V(C2:2)$ and $V(C3:2)$ are the capacitor voltages, listed from top to bottom.

SP 14-5

Make three copies of the circuit: one for each set of parameter values. (Cut and paste, but be sure to edit the labels of the parts so, for example, there is only one R1.)

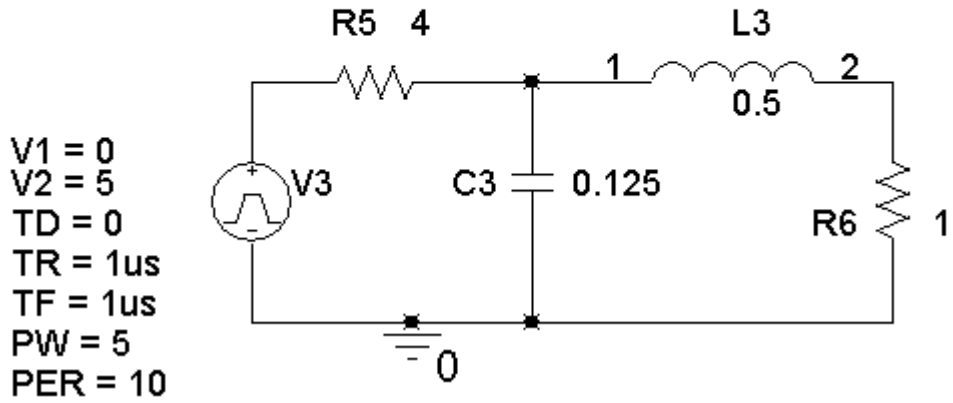
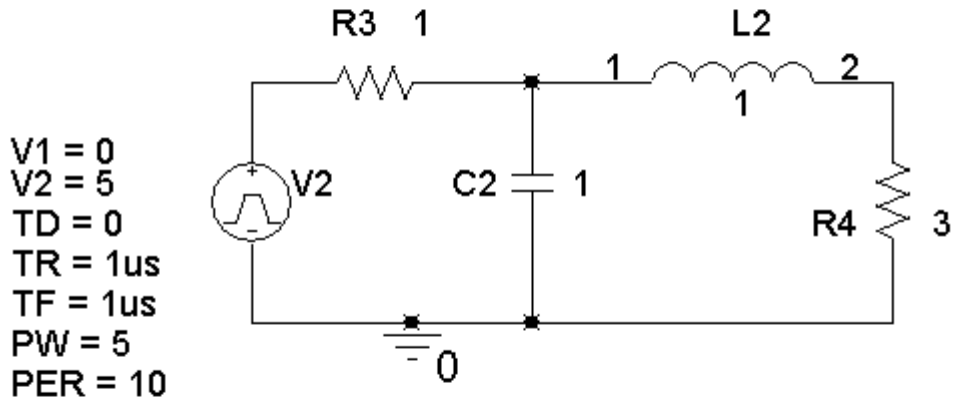
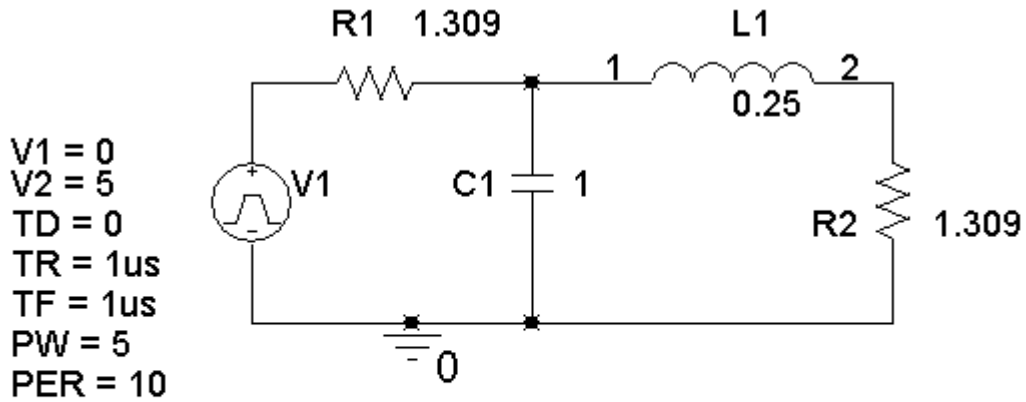

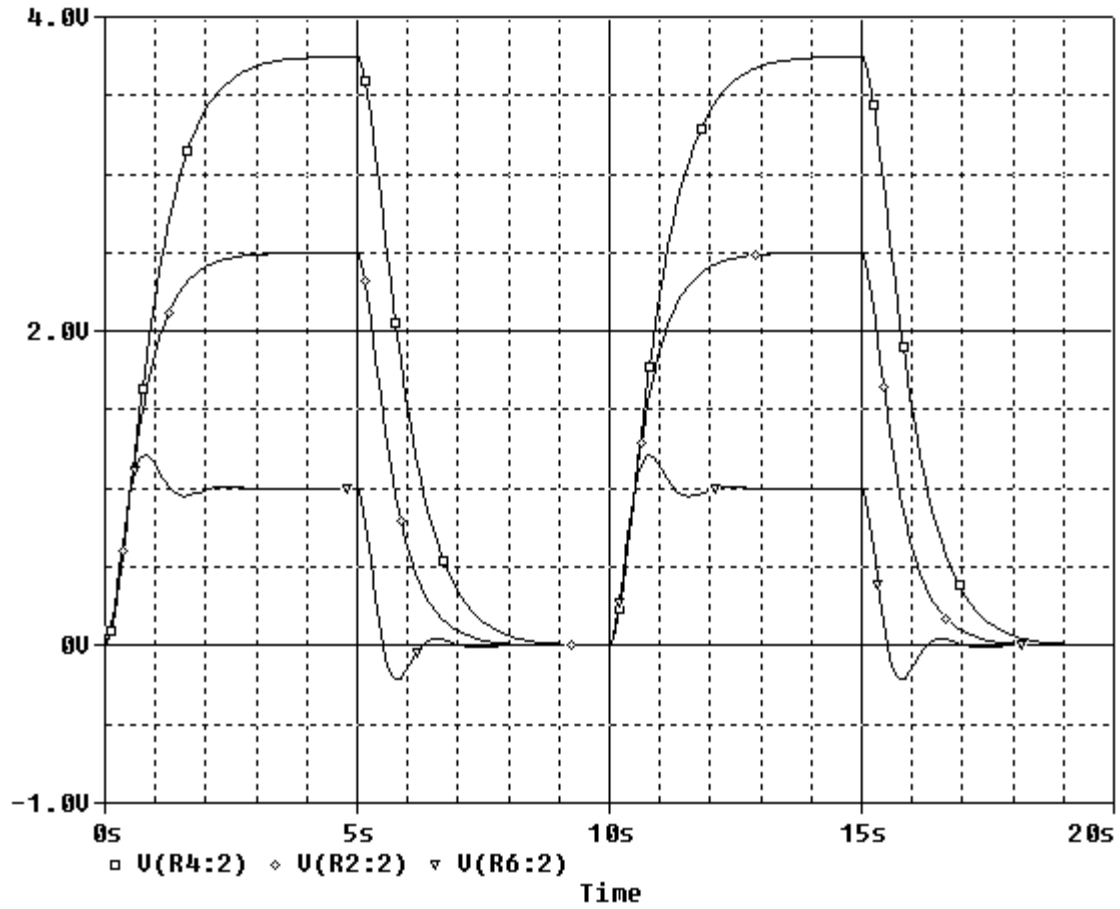

$V(R2:2)$, $V(R4:2)$ and $V(R6:2)$ are the output voltages, listed from top to bottom.

Verification Problems

VP 14-1

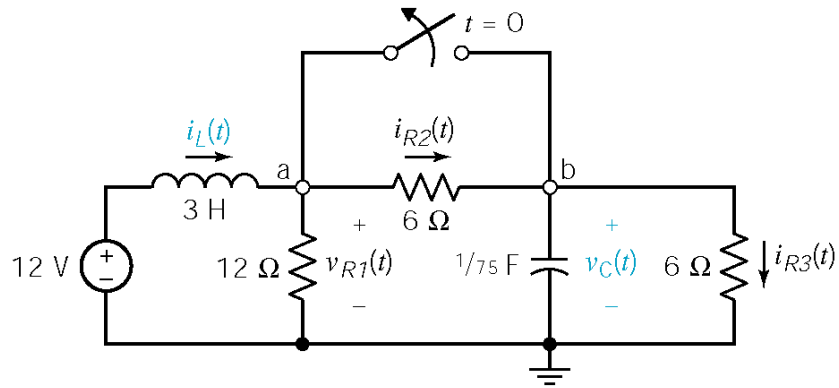

$$v_L(t) = 3 \frac{d}{dt} i_L(t) = -6e^{-2.1t} - 2e^{-15.9t}$$

$$i_C(t) = \frac{1}{75} \frac{d}{dt} v_C(t) = -0.092e^{-2.1t} - 0.575e^{-15.9t}$$

$$v_{R1}(t) = 12 - v_L(t) = 12 + 6e^{-2.1t} + 2e^{-15.9t}$$

$$i_{R2}(t) = \frac{12 - (v_L(t) + v_C(t))}{6} = 1 + 0.456e^{-2.1t} - 0.123e^{-15.9t}$$

$$i_{R3}(t) = \frac{v_C(t)}{6} = 1 + 0.548e^{-2.1t} + 0.452e^{-15.9t}$$

Thus,

$$-12 + v_L(t) + v_{R1}(t) = 0 \quad \text{and} \quad i_{R2}(t) = i_C(t) + i_{R3}(t)$$

as required. The analysis is correct.

VP 14-2

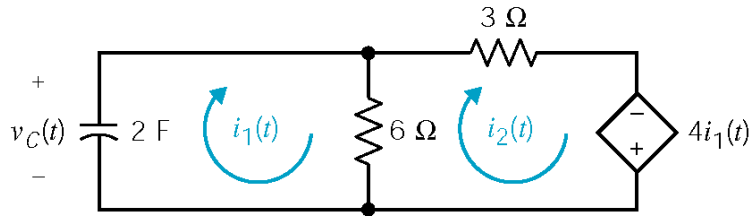

$$I_1(s) = \frac{18}{s - \frac{3}{4}} \quad \text{and} \quad I_2(s) = \frac{20}{s - \frac{3}{4}}$$

KVL for left mesh: $\frac{12}{s} + \frac{1}{2s} \left(\frac{18}{s - \frac{3}{4}} \right) + 6 \left(\frac{18}{s - \frac{3}{4}} - \frac{20}{s - \frac{3}{4}} \right) = 0$ (ok)

KVL for right mesh: $-6 \left(\frac{18}{s - \frac{3}{4}} - \frac{20}{s - \frac{3}{4}} \right) + 3 \left(\frac{20}{s - \frac{3}{4}} \right) - 4 \left(\frac{18}{s - \frac{3}{4}} \right) = 0$ (ok)

The analysis is correct.

VP 14-3

Initial value of $I_L(s)$: $\lim_{s \rightarrow \infty} s \frac{s+2}{s^2+s+5} = 1$ (ok)

Final value of $I_L(s)$: $\lim_{s \rightarrow 0} s \frac{s+2}{s^2+s+5} = 0$ (ok)

Initial value of $V_C(s)$: $\lim_{s \rightarrow \infty} s \frac{-20(s+2)}{s(s^2+s+5)} = 0$ (not ok)

Final value of $V_C(s)$: $\lim_{s \rightarrow 0} s \frac{-20(s+2)}{s(s^2+s+5)} = -8$ (not ok)

Apparently the error occurred as $V_C(s)$ was calculated from $I_L(s)$. Indeed, it appears that $V_C(s)$

was calculated as $-\frac{20}{s} I_L(s)$ instead of $-\frac{20}{s} I_L(s) + \frac{8}{s}$. After correcting this error

$$V_C(s) = -\frac{20}{s} \left(\frac{s+2}{s^2+s+5} \right) + \frac{8}{s}.$$

Initial value of $V_C(s)$: $\lim_{s \rightarrow \infty} s \left(\frac{-20(s+2)}{s(s^2+s+5)} + \frac{8}{s} \right) = 8$ (ok)

Final value of $V_C(s)$: $\lim_{s \rightarrow 0} s \left(\frac{-20(s+2)}{s(s^2+s+5)} + \frac{8}{s} \right) = 0$ (ok)

Design Problems

DP 14-1

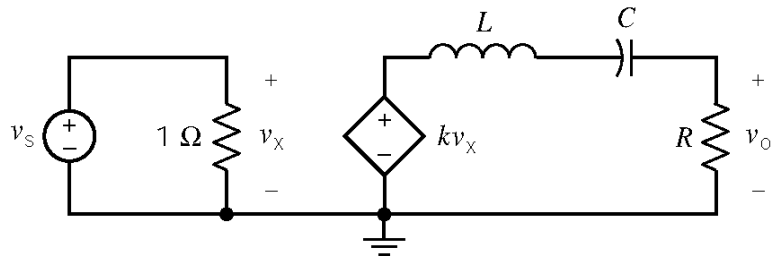

Equating the Laplace transform of the step response of the give circuit to the Laplace transform of the given step response:

$$V_o(s) = \frac{\frac{kR}{L}}{s^2 + \frac{R}{L}s + \frac{1}{LC}} = \frac{5}{(s+4)^2}$$

Equating the poles:

$$s_{1,2} = \frac{-\frac{R}{L} \pm \sqrt{\left(\frac{R}{L}\right)^2 - \frac{4}{LC}}}{2} = -4 \pm 0$$

Summarizing the results of these comparisons:

$$\frac{R}{2L} = 4, R = \frac{2}{\sqrt{LC}} \text{ and } \frac{kR}{L} = 5$$

Pick $L = 1$ H, then $k = 0.625$ V/V, $R = 8 \Omega$ and $C = 0.0625$ F.

DP 14-2

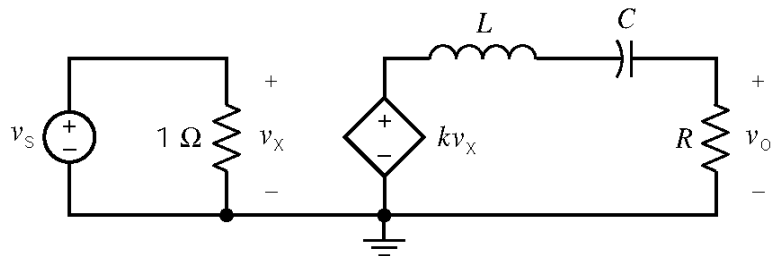

Equating the Laplace transform of the step response of the give circuit to the Laplace transform of the given step response:

$$V_o(s) = \frac{\frac{kR}{L}}{s^2 + \frac{R}{L}s + \frac{1}{LC}} = \frac{10}{(s+4)^2 + 4} = \frac{10}{s^2 + 8s + 20}$$

Equating coefficients:

$$\frac{R}{L} = 8, \quad \frac{1}{LC} = 20, \quad \text{and} \quad \frac{kR}{L} = 10$$

Pick $L = 1$ H, then $k = 1.25$ V/V, $R = 8 \Omega$ and $C = 0.05$ F.

DP 14-3

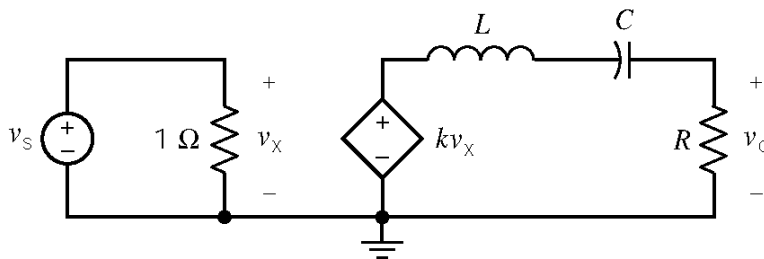

Equating the Laplace transform of the step response of the give circuit to the Laplace transform of the given step response:

$$V_o(s) = \frac{\frac{kR}{L}}{s^2 + \frac{R}{L}s + \frac{1}{LC}} = \frac{5}{(s+2)} - \frac{5}{(s+4)} = \frac{10}{s^2 + 6s + 8}$$

Equating coefficients:

$$\frac{R}{L} = 6, \quad \frac{1}{LC} = 8, \quad \text{and} \quad \frac{kR}{L} = 10$$

Pick $L = 1$ H, then $k = 1.667$ V/V, $R = 6 \Omega$ and $C = 0.125$ F.

DP 14-4

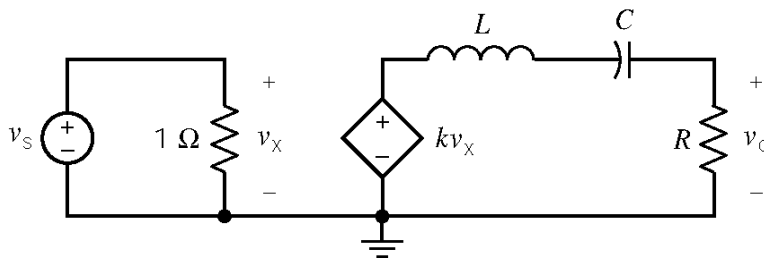

Comparing the Laplace transform of the step response of the give circuit to the Laplace transform of the given step response:

$$V_o(s) = \frac{\frac{kR}{L}}{s^2 + \frac{R}{L}s + \frac{1}{LC}} \neq \frac{5}{(s+2)} + \frac{5}{(s+4)} = \frac{10s+30}{s^2+6s+8}$$

These two functions can not be made equal by any choice of k , R , C and L because the numerators have different forms.

DP 14-5

a) Use voltage division to get

$$\begin{aligned} \frac{V_o(s)}{V_1(s)} &= \frac{\frac{R_2}{sC_2R_2+1}}{\frac{R_1}{sC_1R_1+1} + \frac{R_2}{sC_2R_2+1}} \\ &= \frac{C_1}{C_1+C_2} \left[\frac{s + \frac{1}{C_1R_1}}{s + \frac{R_1+R_2}{R_1R_2(C_1+C_2)}} \right] \end{aligned}$$

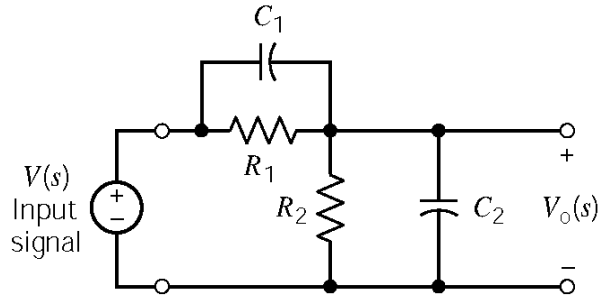

b) To make the natural response be zero, we eliminate the pole by causing it to cancel the zero.

$$-\frac{1}{C_1R_1} = -\frac{R_1+R_2}{R_1R_2(C_1+C_2)} \Rightarrow \frac{C_2}{C_1} = \frac{R_1}{R_2}$$

c) Let $v_1(t) = u(t) \Rightarrow V_1(s) = \frac{1}{s}$. Then

$$V_o(s) = \frac{C_1}{C_1+C_2} \left[\frac{s + \frac{1}{R_1C_1}}{s \left\{ s + \frac{R_1+R_2}{R_1R_2(C_1+C_2)} \right\}} \right] = \frac{K_1}{s} + \frac{K_2}{s + \frac{R_1+R_2}{R_1R_2(C_1+C_2)}}$$

where $K_1 = \frac{R_2}{R_1+R_2}$ and $K_2 = \frac{C_1}{C_1+C_2} - \frac{R_2}{R_1+R_2}$

Then

$$v_o(t) = \left[\frac{R_2}{R_1+R_2} + \left(\frac{C_1}{C_1+C_2} - \frac{R_2}{R_1+R_2} \right) e^{-t/\tau} \right] u(t)$$

where $\tau = \frac{R_1 R_2 (C_1 + C_2)}{R_1 + R_2}$. To make the step response be proportional to the step in put, we require

$$\frac{C_1}{C_1 + C_2} = \frac{R_2}{R_1 + R_2}$$

Then

$$v_o(t) = \frac{R_2}{R_1 + R_2} u(t)$$

DP 14-6

The initial conditions are $v_c(0) = -0.4$ V and $i(0) = 0$ A. Consider the circuit after $t = 0$. A source transformation yields

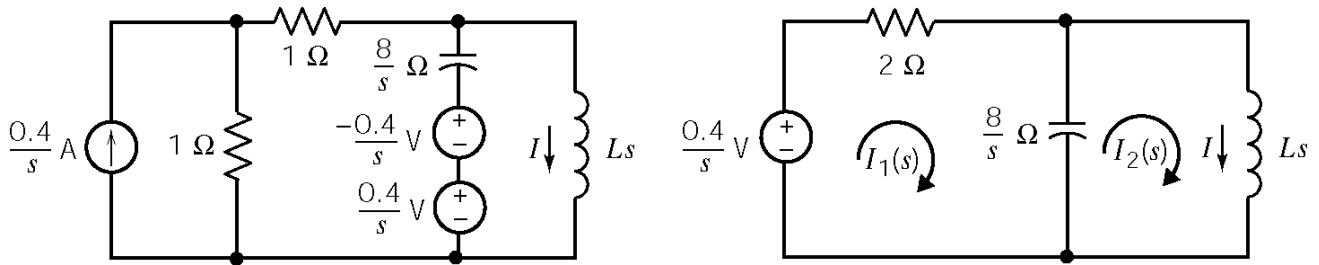

The mesh equations are

$$\begin{aligned} \left(2 + \frac{8}{s}\right) I_1(s) - \frac{8}{s} I_2(s) &= \frac{0.4}{s} \\ -\frac{8}{s} I_1(s) + \left(Ls + \frac{8}{s}\right) I_2(s) &= 0 \end{aligned}$$

Solving for $I_2(s)$ yields

$$I_2(s) = \frac{1.6}{s(Ls^2 + 4Ls + 8)}$$

Therefore, the characteristic equation is

$$s^2 + 4s + \frac{8}{L} = 0$$

We require complex roots with significant damping. Try $L = 1$ H. Then

$$I(s) = \frac{1.6}{s(s^2 + 4s + 8)} = \frac{0.2}{s} + \frac{-0.2(s+4)}{s^2 + 4s + 8} = \frac{0.2}{s} + \frac{-0.2(s+2)}{(s+2)^2 + 4} - \frac{0.8}{(s+2)^2 + 4}$$

Finally

$$i(t) = [0.2 - 0.2e^{-2t} \cos 2t - 0.4e^{-2t} \sin 2t] u(t) \text{ A}$$

Chapter 15: – Fourier Series

Exercises

Ex. 15.3-1

Notice that $f(t-T) = f_1(t-T) + f_2(t-T) = f_1(t) + f_2(t) = f(t)$

Therefore, $f(t)$ is a periodic function having the same period, T . Next

$$\begin{aligned} f(t) &= k_1 f_1(t) + k_2 f_2(t) \\ &= k_1 \left[a_{10} + \sum_{n=1}^{\infty} (a_{1n} \cos(n\omega_0 t) + b_{1n} \sin(n\omega_0 t)) \right] \\ &\quad + k_2 \left[a_{20} + \sum_{n=1}^{\infty} (a_{2n} \cos(n\omega_0 t) + b_{2n} \sin(n\omega_0 t)) \right] \\ &= (k_1 a_{10} + k_2 a_{20}) + \sum_{n=1}^{\infty} ((k_1 a_{1n} + k_2 a_{2n}) \cos(n\omega_0 t) + (k_1 b_{1n} + k_2 b_{2n}) \sin(n\omega_0 t)) \end{aligned}$$

Ex. 15.3-1

$f(t) = K$ is a Fourier Series. The coefficients are $a_0 = K$; $a_n = b_n = 0$ for $n \geq 1$.

Ex. 15.3-2

$f(t) = A \cos \omega_0 t$ is a Fourier Series. $a_1 = A$ and all other coefficients are zero.

Ex. 15.4-1

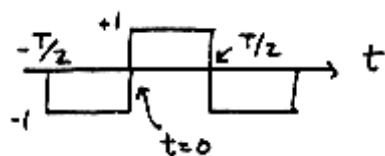

$$T = 4 \left(\frac{\pi}{8} \right) = \frac{\pi}{2}, \quad \omega_0 = \frac{2\pi}{T} = 4 \text{ rad/s}$$

Set origin at $t = 0$, so have an odd function; then $a_n = 0$ for $n = 0, 1, \dots$. Also, $f(t)$ has half wave symmetry, so $b_n = 0$ for $n = \text{even}$. For odd n , we have

$$\begin{aligned} b_n &= \frac{2}{T} \int_{-T/2}^{T/2} f(t) \sin(n\omega_0 t) dt = -\frac{2}{T} \int_{-T/2}^0 \sin(n\omega_0 t) dt + \frac{2}{T} \int_0^{T/2} \sin(n\omega_0 t) dt \\ &= \frac{4}{T} \int_0^{T/2} \sin(n\omega_0 t) dt \\ &= \frac{4}{2\pi n f_0 T} (1 - \cos(n\omega_0 T)) = \frac{4}{n\pi} \quad n = 1, 3, 5, \dots \end{aligned}$$

Finally,

$$\underline{f(t) = \frac{4}{\pi} \sum_{n \text{ odd}} \frac{1}{n} \sin n\omega_0 t; \quad n \text{ odd and } \omega_0 = 4 \text{ rad/s}}$$

Ex. 15.4-2

$$T = \pi, \quad \omega_0 = \frac{2\pi}{T} = 2$$

$$\text{odd function with quarter wave symmetry} \Rightarrow \begin{cases} a_0 = 0, & a_n = 0 \text{ for all } n \\ b_n = 0 & n = \text{even} \end{cases}$$

$$b_n = \frac{8}{\pi} \int_0^{\pi/4} f(t) \sin n\omega_0 t dt \quad \text{where } f(t) = \begin{cases} \frac{-2t}{\pi/6} & 0 < t < \pi/6 \\ -2 & \pi/6 \leq t < \pi/4 \end{cases}$$

$$\text{Thus } b_n = \frac{-24}{\pi^2} \frac{1}{n^2} \sin \left(\frac{n\pi}{3} \right)$$

$$\text{so } \underline{f(t) = \frac{-24}{\pi^2} \sum_{\substack{n=1 \\ \text{odd } n}}^{\infty} \frac{1}{n^2} \sin \left(\frac{n\pi}{3} \right) \sin (2nt)}$$

Ex. 15.4-3

- a) is neither even nor odd. $f(t)$ will contain both sine and cosine terms
 b) $\frac{1}{4}$ wave symmetry \Rightarrow no even harmonics
 c) average value of $f(t) = 0 \Rightarrow a_0 = 0$

Ex. 15.5-1

$$T = 2 \text{ s}, \omega_0 = \frac{2\pi}{T} = \pi \text{ rad/s}$$

$$\begin{aligned} C_n &= \frac{1}{2} \int_0^2 f(t) e^{-jn\pi t} dt = \frac{1}{2} \int_0^1 e^{-jn\pi t} dt - \frac{1}{2} \int_1^2 e^{-jn\pi t} dt \\ &= \frac{1}{2jn\pi} \left[-e^{-jn\pi} + 1 + e^{-j2n\pi} - e^{-jn\pi} \right] = \frac{1}{jn\pi} (1 - e^{-jn\pi}) \end{aligned}$$

$$C_n = \begin{cases} \frac{2}{jn\pi} & n \text{ odd} \\ 0 & n \text{ even} \end{cases}$$

Finally,

$$f(t) = \frac{2}{j\pi} \left[e^{j\pi t} + \frac{1}{3} e^{j3\pi t} + \frac{1}{5} e^{j5\pi t} + \dots - e^{-j\pi t} - \frac{1}{3} e^{-j3\pi t} - \frac{1}{5} e^{-j5\pi t} - \dots \right]$$

Ex. 15.5-3

$$C_n = \frac{1}{T} \int_{-T/4}^{T/4} e^{-j\omega_0 n t} dt = \frac{1}{T} \left(\frac{T}{-j2\pi n} \right) e^{-j2\pi n t / T} \Big|_{-T/4}^{T/4} = \frac{1}{-j2\pi n} \left[e^{-j\pi n / 2} - e^{j\pi n / 2} \right]$$

$$C_n = \begin{cases} \frac{(-1)^{(n-1)/2}}{\pi n} & n \text{ odd} \\ 0 & n \text{ even}, n \neq 0 \\ 1/2 & n = 0 \end{cases}$$

Ex. 15.6-1

Use the “stem plot” in Matlab to plot the required Fourier spectra:

```
% Fourier Spectrum of a Pulse Train

A = 8;           % pulse amplitude
T = 4;           % period
d = T/8;         % pulse width
pi = 3.14159;
w0 = 2*pi/T;     %fundamental frequency

N = 49;
n = linspace(-N,N,2*N+1);
x = n*w0*d/2;

% Eqn.15.6-3. Division by zero when n=0 causes Cn(N+1) to be NaN.
Cn = (A*d/T)*sin(x)./x;
Cn(N+1)=A*d/T;   % Fix Cn(N+1); sin(0)/0 = 1

% Plot the spectrum using a stem plot
stem(n,Cn,'filled');
xlabel('n');
ylabel('|Cn|');
title('Fourier Spectrum of Pules Train with d = T/8');
```

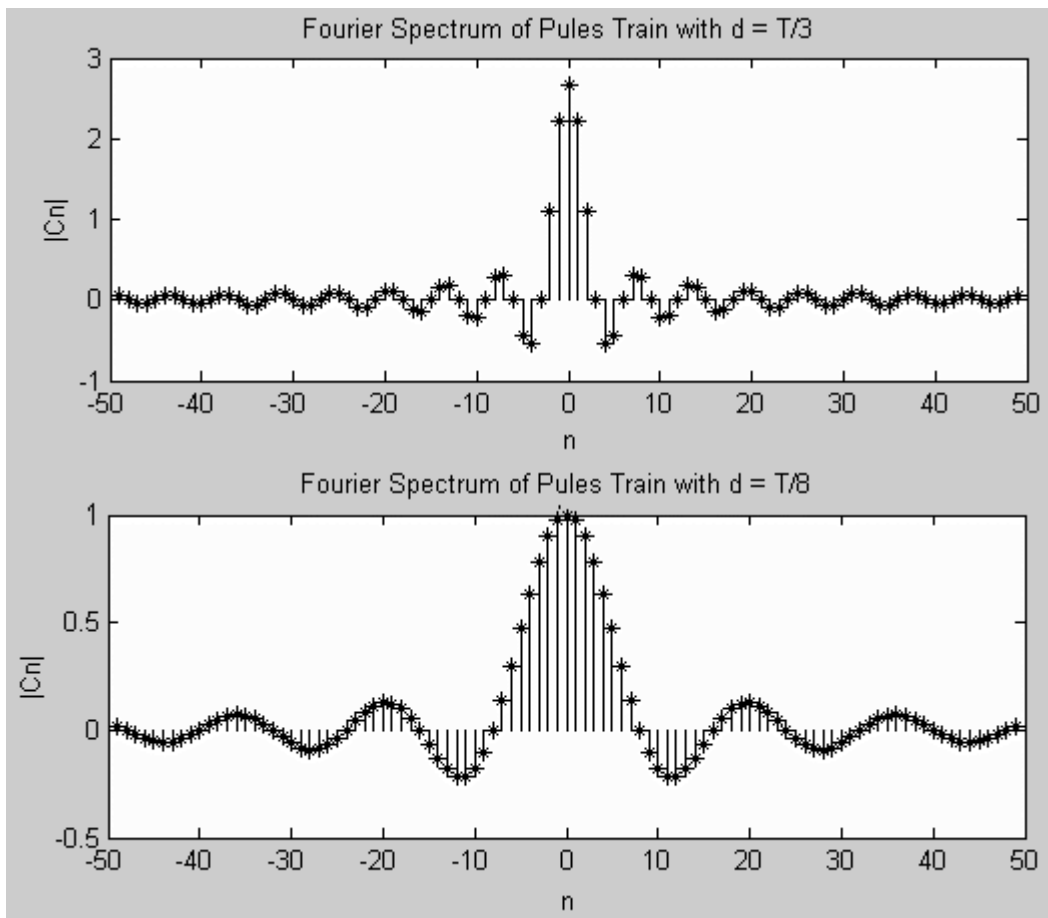

Ex. 15.8-1

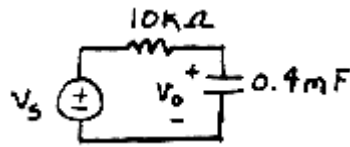

$$\omega_0 = 4 \text{ rad/s}$$

From Example 15.4-1:

$$v_s(t) = 3.24 \sum_{\substack{n=1 \\ \text{odd } n}}^N \frac{1}{n^2} \left(\sin \frac{n\pi}{2} \right) \sin n\omega_0 t = 3.24 \left(\sin 4t - \frac{1}{9} \sin 12t + \frac{1}{25} \sin 20t - \frac{1}{49} \sin 28t \dots \right)$$

The network function of the circuit is

$$\mathbf{H}(\omega) = \frac{\mathbf{V}_o(\omega)}{\mathbf{V}_s(\omega)} = \frac{\frac{1}{j\omega C}}{R + \frac{1}{j\omega C}} = \frac{1}{1 + j\omega CR} = \frac{1}{1 + j\omega 4}$$

Evaluating the network function at the frequencies of the input series

$$\mathbf{H}(n4) = \frac{1}{1 + j16n} \quad n = 1, 3, 5, \dots$$

n	$\mathbf{H}(n4)$
1	$0.062 \angle -86^\circ$
3	$0.021 \angle -89^\circ$
5	$0.012 \angle -89^\circ$
7	$0.0009 \angle -89^\circ$

Using superposition

$$v_o(t) = 3.24 \left((0.062) \sin(4t - 86^\circ) - \frac{0.021}{9} \sin(12t - 89^\circ) + \frac{0.012}{25} \sin(20t - 89^\circ) - \frac{0.0009}{49} \sin(28t - 89^\circ) \dots \right)$$

$$v_o(t) = (0.2009) \sin(4t - 86^\circ) - (.00756) \sin(12t - 89^\circ) + (0.00156) \sin(20t - 89^\circ) - (5.95 \times 10^{-5}) \sin(28t - 89^\circ) \dots$$

Discarding the terms that are smaller than 25 of the fundamental term leaves

$$v_o(t) = (0.2009) \sin(4t - 86^\circ) - (.00756) \sin(12t - 89^\circ)$$

Ex. 15.9-1

$$f(t) = e^{-at}u(t)$$

$$F(\omega) = \int_{-\infty}^{+\infty} f(t) e^{j\omega t} dt = \int_0^{\infty} e^{-at} e^{j\omega t} dt = \frac{e^{-(a+j\omega)t}}{-(a+j\omega)} \Big|_0^{\infty} = \frac{1}{a+j\omega}$$

Ex. 15.10-1

$$\mathcal{F}\{f(at)\} = \int_{-\infty}^{\infty} f(at) e^{-j\omega t} dt$$

$$\text{Let } \tau = at \Rightarrow t = \frac{\tau}{a}$$

$$\mathcal{F}\{f(at)\} = \int_{-\infty}^{\infty} f(\tau) e^{-j\omega\tau/a} d\frac{\tau}{a} = \frac{1}{a} \int_{-\infty}^{\infty} f(\tau) e^{-j(\omega/a)\tau} d\tau = \frac{1}{a} F\left(\frac{\omega}{a}\right)$$

Ex. 15.10-2

$$f(t) = \frac{1}{2\pi} \int_{-\infty}^{\infty} (2\pi\delta(\omega)A) e^{j\omega t} dt = \frac{1}{2\pi} \int_0^{0^+} (2\pi\delta(\omega)A) dt = A$$

Ex. 15.11-1

$$\mathcal{F}^{-1}\{\delta(\omega - \omega_0)\} = \frac{1}{2\pi} \int_{-\infty}^{\infty} \delta(\omega - \omega_0) e^{j\omega t} dt = \frac{1}{2\pi} e^{j\omega_0 t}$$

Take the Fourier Transform of both sides to get: $\mathcal{F}(e^{j\omega_0 t}) = 2\pi\delta(\omega - \omega_0)$

$$\begin{aligned} \mathcal{F}\{A \cos \omega_0 t\} &= \mathcal{F}\left\{A \left(\frac{e^{j\omega_0 t} + e^{-j\omega_0 t}}{2}\right)\right\} = \frac{A}{2} (\mathcal{F}(e^{j\omega_0 t}) + \mathcal{F}(e^{-j\omega_0 t})) = \frac{A}{2} (2\pi\delta(\omega - \omega_0) + 2\pi\delta(\omega + \omega_0)) \\ &= A\pi\delta(\omega - \omega_0) + A\pi\delta(\omega + \omega_0) \end{aligned}$$

Ex. 15.12-1

a)

$$V_{in}(\omega) = \frac{120}{24 + j\omega} \Rightarrow |V_{in}(\omega)|^2 = \frac{120^2}{24^2 + \omega^2} = \frac{14400}{576 + \omega^2}$$

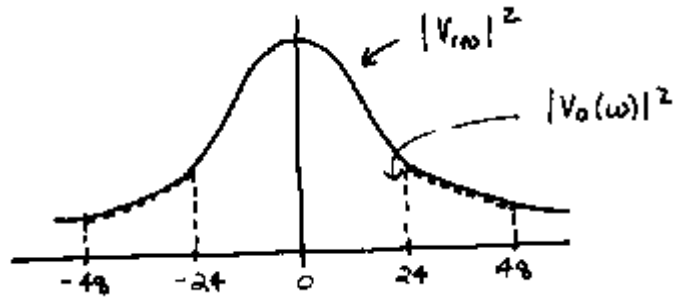

b)

$$W_{in} = \frac{1}{\pi} \int_0^{\infty} \frac{14400}{576 + \omega^2} d\omega = \frac{14000}{\pi} \left(\frac{1}{24} \tan^{-1} \left(\frac{\omega}{24} \right) \right)_0^{\infty} = 300 \text{ J}$$

$$W_{out} = \frac{1}{\pi} \int_{24}^{48} \frac{14400}{576 + \omega^2} d\omega = \frac{14000}{\pi} \left(\frac{1}{24} \tan^{-1} \left(\frac{\omega}{24} \right) \right)_{24}^{48} = 61.3 \text{ J}$$

$$\therefore \eta = \frac{W_{out}}{W_{in}} \times 100\% = \frac{61.3}{300} \times 100\% = 20.5\%$$

Ex. 15.13-1

$$f^+(t) = te^{-at}$$

$$f^-(t) = te^{at} \Rightarrow f^-(-t) = -te^{-at}$$

$$\therefore F^+(s) = \frac{1}{(s+a)^2} \quad \text{and} \quad F^-(s) = \frac{-1}{(s+a)^2}$$

$$\begin{aligned} \text{Then } F(\omega) &= F^+(s) \Big|_{s=j\omega} + F^-(s) \Big|_{s=-j\omega} = \frac{1}{(s+a)^2} \Big|_{s=j\omega} + \frac{-1}{(s+a)^2} \Big|_{s=-j\omega} \\ &= \frac{1}{(a+j\omega)^2} - \frac{1}{(a-j\omega)^2} = \frac{-j4a\omega}{(a^2 + \omega^2)^2} \end{aligned}$$

Problems

Section 15.3: The Fourier Series

P15.3-1

$T = 2 \text{ s} \Rightarrow \omega_0 = \frac{2\pi}{2} = \pi \text{ rad/s}$ and $f(t) = t^2$ for $0 \leq t \leq 2$. The coefficients of the Fourier series are given by:

$$a_0 = \frac{1}{2} \int_0^2 t^2 dt = 4/3$$

$$a_n = \frac{2}{2} \int_0^2 t^2 \cos n\pi t dt = \frac{4}{(n\pi)^2}$$

$$b_n = \frac{2}{2} \int_0^2 t^2 \sin n\pi t dt = \frac{-4}{n\pi}$$

$$\therefore \underline{f(t) = \frac{4}{3} + \frac{4}{\pi^2} \sum_{n=1}^{\infty} \frac{1}{n^2} \cos n\pi t - \frac{4}{\pi} \sum_{n=1}^{\infty} \frac{1}{n} \sin n\pi t}$$

P15.3-2

$$\begin{aligned}
 a_n &= \frac{2}{T} \left[\int_0^{\frac{T}{4}} \cos \left(n \frac{2\pi}{T} t \right) dt + \int_{\frac{T}{4}}^{\frac{T}{2}} 2 \cos \left(n \frac{2\pi}{T} t \right) dt \right] \\
 &= \frac{1}{n\pi} \left[\sin \left(n \frac{2\pi}{T} t \right) \Big|_0^{\frac{T}{4}} + 2 \sin \left(n \frac{2\pi}{T} t \right) \Big|_{\frac{T}{4}}^{\frac{T}{2}} \right] \\
 &= \frac{1}{n\pi} \left[\left(\sin \left(\frac{n\pi}{2} \right) - 0 \right) + 2 \left(\sin n\pi - \sin \left(\frac{n\pi}{2} \right) \right) \right] \\
 &= -\frac{1}{n\pi} \sin \left(\frac{n\pi}{2} \right) = \begin{cases} \frac{(-1)^{\frac{n+1}{2}}}{n\pi} & \text{odd } n \\ 0 & \text{even } n \end{cases}
 \end{aligned}$$

$$\begin{aligned}
 b_n &= \frac{2}{T} \left[\int_0^{\frac{T}{4}} \sin \left(n \frac{2\pi}{T} t \right) dt + \int_{\frac{T}{4}}^{\frac{T}{2}} 2 \sin \left(n \frac{2\pi}{T} t \right) dt \right] \\
 &= -\frac{1}{n\pi} \left[\cos \left(n \frac{2\pi}{T} t \right) \Big|_0^{\frac{T}{4}} + 2 \cos \left(n \frac{2\pi}{T} t \right) \Big|_{\frac{T}{4}}^{\frac{T}{2}} \right] \\
 &= -\frac{1}{n\pi} \left[(2 \cos n\pi - 1) - \cos \frac{n\pi}{2} \right] \\
 &= \begin{cases} \frac{3}{n\pi} & n \text{ is odd} \\ -\frac{2}{n\pi} & n = 2, 6, 10, \dots \\ 0 & n = 4, 8, 12, \dots \end{cases}
 \end{aligned}$$

P15.3-3

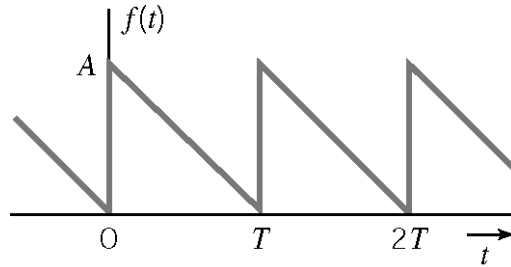

$$a_0 = \text{average value of } f(t) = \frac{A}{2}$$

$$f(t) = A\left(1 - \frac{t}{T}\right) \quad \text{for } 0 \leq t \leq T$$

$$\begin{aligned} a_n &= \frac{2}{T} \int_0^T A\left(1 - \frac{t}{T}\right) \cos\left(n \frac{2\pi}{T} t\right) dt = \frac{2A}{T} \left[\int_0^T \cos\left(n \frac{2\pi}{T} t\right) dt - \frac{1}{T} \int_0^T t \cos\left(n \frac{2\pi}{T} t\right) dt \right] \\ &= \frac{2A}{T} \left[0 - \frac{1}{T} \frac{\cos\left(n \frac{2\pi}{T} t\right) + \left(n \frac{2\pi}{T} t\right) \sin\left(n \frac{2\pi}{T} t\right)}{\left(n \frac{2\pi}{T}\right)^2} \right]_0^T \\ &= \frac{-A}{2n^2 \pi^2} [\cos(2n\pi) - \cos(0) + 2n\pi \sin(2n\pi) - 0] \\ &= 0 \end{aligned}$$

$$\begin{aligned} b_n &= \frac{2}{T} \int_0^T A\left(1 - \frac{t}{T}\right) \sin\left(n \frac{2\pi}{T} t\right) dt = \frac{2A}{T} \left[\int_0^T \sin\left(n \frac{2\pi}{T} t\right) dt - \frac{1}{T} \int_0^T t \sin\left(n \frac{2\pi}{T} t\right) dt \right] \\ &= \frac{2A}{T} \left[0 - \frac{1}{T} \frac{\sin\left(n \frac{2\pi}{T} t\right) - \left(n \frac{2\pi}{T} t\right) \cos\left(n \frac{2\pi}{T} t\right)}{\left(n \frac{2\pi}{T}\right)^2} \right]_0^T \\ &= \frac{-A}{2n^2 \pi^2} [(\sin(2n\pi) - \sin(0)) - (2n\pi \cos(2n\pi) - 0)] \\ &= \frac{A}{n\pi} \end{aligned}$$

$$f(t) = \frac{A}{2} + \sum_{n=1}^{\infty} \frac{A}{n\pi} \sin\left(n \frac{2\pi}{T} t\right)$$

P15.3-4

$$T = 2 \text{ s}, \quad \omega_0 = \frac{2\pi}{2} = \pi \text{ rad/s}, \quad a_0 = \text{average value of } f(t) = 1,$$

$$f(t) = t \quad \text{for } 0 \leq t \leq 2$$

$$\begin{aligned} a_n &= \frac{2}{2} \int_0^2 t \cos(n\pi t) dt = \left. \frac{\cos(n\pi t) + (n\pi t) \sin(n\pi t)}{(n\pi)^2} \right|_0^2 \\ &= \frac{1}{n^2 \pi^2} [\cos(2n\pi) - \cos(0) + 2n\pi \sin(2n\pi) - 0] \\ &= 0 \end{aligned}$$

$$\begin{aligned} b_n &= \frac{2}{2} \int_0^2 t \sin(n\pi t) dt = \left. \frac{\sin(n\pi t) - (n\pi t) \cos(n\pi t)}{(n\pi)^2} \right|_0^2 \\ &= \frac{1}{n^2 \pi^2} [(\sin(2n\pi) - \sin(0)) - (2n\pi \cos(2n\pi) - 0)] \\ &= \frac{-2}{n\pi} \end{aligned}$$

$$f(t) = 1 - \sum_{n=1}^{\infty} \frac{2}{n\pi} \sin\left(n \frac{2\pi}{T} t\right)$$

Use Matlab to check this answer:

```
% P15.3-4
pi=3.14159;
A=2;           % input waveform parameters
T=2;          % period

w0=2*pi/T;    % fundamental frequency, rad/s
tf=2*T;       % final time
dt=tf/200;    % time increment
t=0:dt:tf;    % time, s

a0=A/2;       % average value of input
v1=0*t+a0;    % initialize input as vector

for n=1:1:51  % for each term in the Fourier series ...
    an=0;     % specify coefficients of the input series
    bn=-A/pi/n;
    cn=sqrt(an*an + bn*bn); % convert to magnitude and angle form
    thetan=-atan2(bn,an);
    v1=v1+cn*cos(n*w0*t+thetan); % add the next term of the input
Fourier series
end
```

```
plot(t, v1, 'black')    % plot the Fourier series

grid
xlabel('t, s')
ylabel('f(t)')
title('P15.3-4')
```

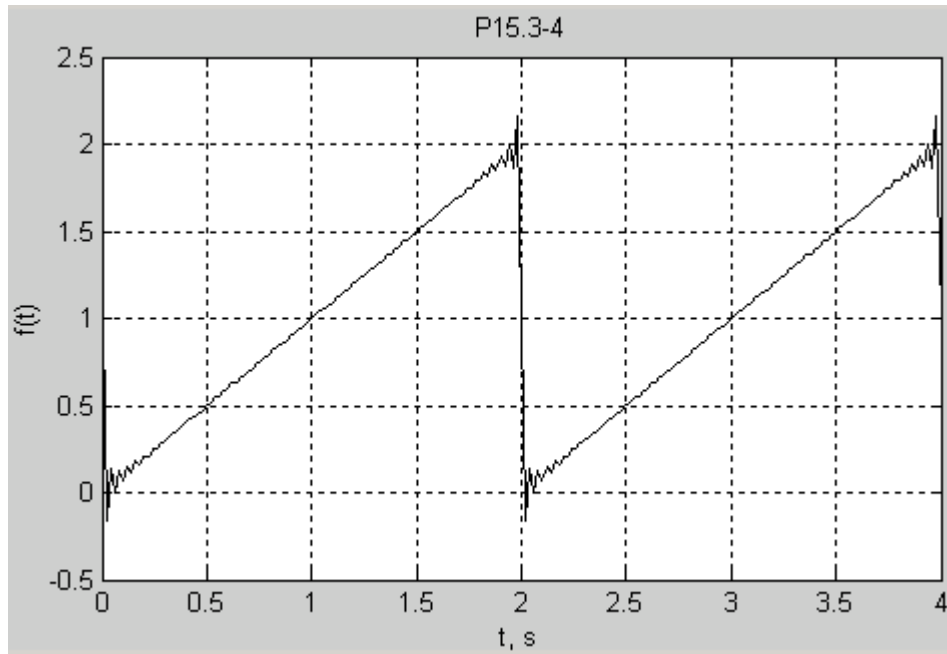

Section 15-4: Symmetry of the Function $f(t)$

15.4-1 $T = 4 \text{ s} \Rightarrow \omega_0 = \frac{2\pi}{4} = \frac{\pi}{2} \text{ rad/s}.$

The coefficients of the Fourier series are:

$$a_0 = \text{average value of } v_d(t) = 0$$

$$a_n = 0 \text{ because } v_d(t) \text{ is an odd function of } t.$$

$$\begin{aligned} b_n &= \frac{1}{2} \int_0^4 (6 - 3t) \sin\left(n \frac{\pi}{2} t\right) dt \\ &= 3 \int_0^4 \sin\left(n \frac{\pi}{2} t\right) dt - \frac{3}{2} \int_0^4 t \sin\left(n \frac{\pi}{2} t\right) dt \\ &= 3 \left[\frac{-\cos\left(n \frac{\pi}{2} t\right)}{n \frac{\pi}{2}} \right]_0^4 - \frac{3}{2} \left[\frac{1}{n^2 \pi^2} \sin\left(n \frac{\pi}{2} t\right) - \left(n \frac{\pi}{2} t\right) \cos\left(n \frac{\pi}{2} t\right) \right]_0^4 \\ &= \frac{6}{n\pi} (-1 + \cos(2n\pi)) - \frac{6}{n^2 \pi^2} ((\sin(2n\pi) - 0) - (2n\pi \cos(2n\pi))) \\ &= \frac{12}{n\pi} \end{aligned}$$

The Fourier series is:

$$v_d(t) = \sum_{n=1}^{\infty} \frac{12}{n\pi} \sin\left(n \frac{\pi}{2} t\right)$$

P15.4-2

$$v_c(t) = v_d(t-1) - 6 = -6 + \sum_{n=1}^{\infty} \frac{12}{n\pi} \sin\left(n \frac{\pi}{2} (t-1)\right) = -6 + \sum_{n=1}^{\infty} \frac{12}{n\pi} \sin\left(n \frac{\pi}{2} t - n \frac{\pi}{2}\right)$$

P15.4-3

$$T = 6 \text{ ms} = 0.006 \text{ s} \Rightarrow \omega_0 = \frac{2\pi}{0.006} = \frac{1000\pi}{3} \text{ rad/s} = \frac{\pi}{3} \text{ krad/s}$$

The coefficients of the Fourier series are:

$$a_0 = \text{average value of } v_a(t) = \frac{3 \times 2}{6} = \frac{1}{2} \text{ V}$$

$b_n = 0$ because $v_a(t)$ is an even function of t .

$$\begin{aligned} a_n &= 2 \left(\frac{2}{0.006} \right) \int_0^{0.001} (3 - 3000t) \cos \left(n \frac{1000\pi}{3} t \right) dt \\ &= 2000 \int_0^{0.001} \cos \left(n \frac{1000\pi}{3} t \right) dt - (2 \times 10^6) \int_0^{0.001} t \cos \left(n \frac{1000\pi}{3} t \right) dt \\ &= 2000 \left[\frac{\sin \left(n \frac{1000\pi}{3} t \right)}{n \frac{1000\pi}{3}} - \frac{1000}{n^2 10^6 \pi^2} \left(\cos \left(n \frac{1000\pi}{3} t \right) + \left(n \frac{1000\pi}{3} t \right) \sin \left(n \frac{1000\pi}{3} t \right) \right) \right]_0^{0.001} \\ &= 2000 \left[\frac{3}{n 1000 \pi} \left(\sin \left(n \frac{\pi}{3} \right) - 0 \right) - \frac{9}{n^2 10^3 \pi^2} \left(\left(\cos \left(n \frac{\pi}{3} \right) - 1 \right) + \left(n \frac{\pi}{3} \right) \sin \left(n \frac{\pi}{3} \right) - 0 \right) \right] \\ &= \frac{6}{n \pi} \sin \left(n \frac{\pi}{3} \right) - \left(\frac{18}{n^2 \pi^2} \right) \left(\cos \left(n \frac{\pi}{3} \right) - 1 \right) - \frac{6}{n \pi} \sin \left(n \frac{\pi}{3} \right) \\ &= - \left(\frac{18}{n^2 \pi^2} \right) \left(\cos \left(n \frac{\pi}{3} \right) - 1 \right) \end{aligned}$$

The Fourier series is

$$v_a(t) = \frac{1}{2} + \sum_{n=1}^{\infty} \frac{18}{n^2 \pi^2} \left(1 - \cos \left(\frac{n\pi}{3} \right) \right) \cos \left(n \frac{1000\pi}{3} t \right)$$

P15.4-4

$$\begin{aligned} v_b(t) &= v_a(t-2) - 1 = -1 + \frac{1}{2} + \sum_{n=1}^{\infty} \frac{18}{n^2 \pi^2} \left(1 - \cos \left(\frac{n\pi}{3} \right) \right) \cos \left(n \frac{\pi}{3} (t-2) \right) \\ &= -\frac{1}{2} + \sum_{n=1}^{\infty} \frac{18}{n^2 \pi^2} \left(1 - \cos \left(\frac{n\pi}{3} \right) \right) \cos \left(n \frac{1000\pi}{3} t - n \frac{2\pi}{3} \right) \end{aligned}$$

P15.4-5

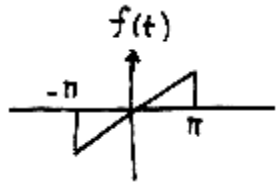

$$f(t) = t \quad -\pi < t < \pi$$

Choose $t_0 = -\pi$

$$T = 2\pi, \quad \omega_0 = \frac{2\pi}{2\pi} = 1$$

average value: $a_0 = 0$

$$b_n = \frac{2}{T} \int_0^T f(t) \sin n\omega_0 t \, dt$$

$a_n = 0$ since have odd function

$$b_n = \frac{2}{2\pi} \int_{-\pi}^{\pi} t \sin nt \, dt$$

$$= \frac{1}{\pi} \left[\frac{\sin nt}{n^2} - \frac{t \cos nt}{n} \right]_{-\pi}^{\pi}$$

$$b_1 = \frac{1}{\pi} \left[\frac{\pi}{1} + \frac{\pi}{1} \right] = 2$$

$$b_2 = -1$$

$$b_3 = 2/3$$

P15.4-6

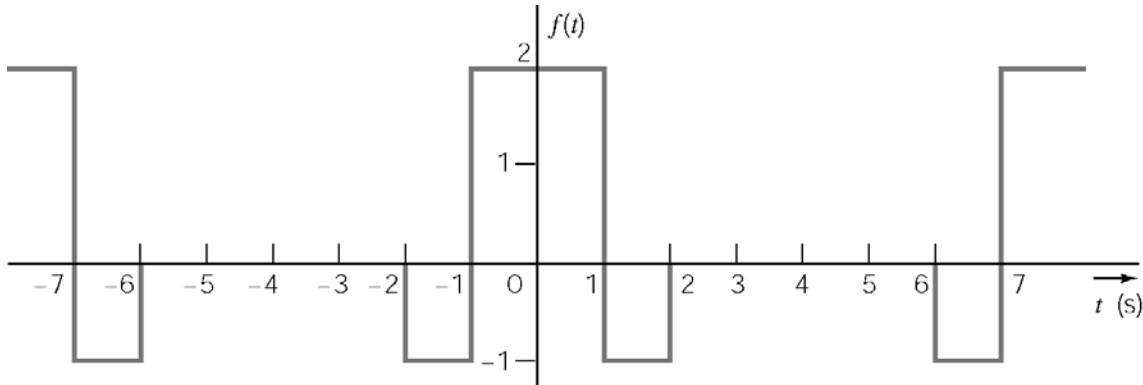

$$T = 8 \text{ s}, \quad \omega_0 = \pi/4 \text{ rad/s}$$

$b_n = 0$ because $f(t)$ is an even function

$$a_0 = \text{average} = \frac{(2 \times 2) - 2 \times 1}{8} = 1/4$$

$$a_n = \frac{4}{T} \int_0^{T/2} f(t) \cos n\omega_0 t \, dt$$

$$= \frac{4}{8} \left[\int_0^1 2 \cos n\frac{\pi}{4}t \, dt - \int_1^2 \cos n\frac{\pi}{4}t \, dt \right]$$

$$= \frac{2}{n\pi} \left[3 \sin \frac{n\pi}{4} - \sin \frac{n\pi}{2} \right]$$

$$a_1 = .714, \quad a_2 = .955, \quad a_3 = .662$$

P15.4-7

$$\omega_0 = 2\omega, \quad T = \frac{\pi}{\omega}$$

$$a_0 = \frac{\omega}{\pi} \int_{-\frac{\pi}{2\omega}}^{\frac{\pi}{2\omega}} A \cos \omega t \, dt = \frac{2A}{\pi}$$

$$a_n = \frac{2\omega}{\pi} \int_{-\frac{\pi}{2\omega}}^{\frac{\pi}{2\omega}} A \cos \omega t \cos 2n\omega t \, dt$$

$$= \frac{2\omega A}{\pi} \left[\frac{\sin(2n-1)\omega t}{2(2n-1)\omega} + \frac{\sin(2n+1)\omega t}{2(2n+1)\omega} \right]_{-\frac{\pi}{2\omega}}^{\frac{\pi}{2\omega}}$$

$$= \frac{2A}{\pi} \left[\frac{\sin(2n-1)\frac{\pi}{2}}{2n-1} + \frac{\sin(2n+1)\frac{\pi}{2}}{2n+1} \right]$$

$$= \frac{2A}{\pi(4n^2-1)} \left[(2n+1) \sin(2n-1) \frac{\pi}{2} - (2n-1) \sin(2n-1) \frac{\pi}{2} \right]$$

$$= -\frac{4A}{\pi(4n^2-1)} \cos(n\pi)$$

$$= -\frac{4A(-1)^n}{\pi(4n^2-1)}$$

$b_n = 0$ due to symmetry

P15.4-8

$$T = 0.4 \text{ s}, \quad \Rightarrow \quad \omega_0 = \frac{2\pi}{T} = 5\pi \text{ rad/s}$$

$$f(t) = \begin{cases} A \cos \omega_0 t & 0 \leq t \leq .1 \\ 0 & .1 \leq t < .3 \\ A \cos \omega_0 t & .3 \leq t \leq .4 \end{cases}$$

Choose period $-1 \leq t \leq .3$ for integral

$$a_0 = \frac{1}{T} \int_{-1}^{.1} A \cos \omega_0 t \, dt = A/\pi$$

$$a_n = \frac{2}{T} \int_{-1}^{.1} A \cos \omega_0 t \cos n\omega_0 t \, dt$$

$$a_1 = 5A \int_{-1}^1 \cos^2 \omega_0 t \, dt = \frac{A}{2}$$

$$\begin{aligned} a_n &= 5A \int_{-1}^1 \cos \omega_0 t \cos n\omega_0 t \, dt \\ &= 5A \int_{-1}^1 \frac{1}{2} [\cos 5\pi(1+n)t + \cos 5\pi(1-n)t] \, dt \\ &= \frac{2A}{\pi} \frac{\cos(n\pi/2)}{1-n^2} \quad n \neq 1 \end{aligned}$$

$$\underline{b_n = 0} \text{ because the function is even.}$$

P15.4-9

$$a_0 = 0 \text{ because the average value is zero}$$

$$a_n = 0 \text{ because the function is odd}$$

$$b_n = 0 \text{ for even } n \text{ due to } \frac{1}{4} \text{ wave symmetry}$$

Next:

$$b_n = \int_{-T/4}^{T/4} t \sin(n\omega_0 t) \, dt = \frac{8 \sin\left(\frac{n\pi}{2}\right) - 4n\pi \cos\left(\frac{n\pi}{2}\right)}{n^2 \pi^2} = \begin{cases} \frac{8}{n^2 \pi^2} & \text{for } n = 1, 5, 9, \dots \\ -\frac{8}{n^2 \pi^2} & \text{for } n = 3, 7, 11, \dots \end{cases}$$

Section 15.5: Exponential Form of the Fourier Series

P15.5-1

$T = 1 \Rightarrow \omega_0 = \frac{2\pi}{1} = 2\pi$, the coefficients of the complex Fourier series are given by:

$$\begin{aligned} C_n &= \frac{1}{1} \int_0^1 A \sin(\pi t) e^{-j2\pi n t} \, dt = \int_0^1 A \left(\frac{e^{j\pi t} - e^{-j\pi t}}{2j} \right) e^{-j2\pi n t} \, dt \\ &= \frac{A}{2j} \int_0^1 \left(e^{-j\pi(2n-1)t} - e^{-j\pi(2n+1)t} \right) \, dt \\ &= \frac{A}{2j} \left[\frac{e^{-j\pi(2n-1)t}}{-j\pi(2n-1)} - \frac{e^{-j\pi(2n+1)t}}{-j\pi(2n+1)} \right]_0^1 = \frac{-2A}{\pi(4n^2 - 1)} \end{aligned}$$

where we have used $e^{\pm j2\pi n} = 1$ and $e^{j\pi} = e^{-j\pi}$.

P15.5-2

$$C_n = \frac{1}{T} \int_0^1 \left(\frac{A}{T} t \right) e^{-j \frac{2\pi}{T} n t} dt = \frac{A}{T^2} \int_0^1 t e^{-j \frac{2\pi}{T} n t} dt$$

Recall the formula for integrating by parts: $\int_{t_1}^{t_2} u dv = u v \Big|_{t_1}^{t_2} - \int_{t_1}^{t_2} v du$. Take $u = t$ and

$dv = e^{-j \frac{2\pi}{T} n t} dt$. When $n \neq 0$, we get

$$\begin{aligned} C_n &= \frac{A}{T^2} \left(\left. \frac{t e^{-j \frac{2\pi}{T} n t}}{-j \frac{2\pi}{T} n} \right|_0^T + \frac{1}{j \frac{2\pi}{T} n} \int_0^T e^{-j \frac{2\pi}{T} n t} dt \right) \\ &= \frac{A}{T} \left(\left. \frac{T e^{-j 2\pi n}}{-j 2\pi n} + \frac{e^{-j \frac{2\pi}{T} n t}}{\left(j \frac{2\pi}{T} n \right)^2} \right|_0^T \right) \\ &= \frac{A}{T} \left(\frac{T e^{-j 2\pi n}}{-j 2\pi n} + \frac{e^{-j 2\pi n} - 1}{\left(j \frac{2\pi}{T} n \right)^2} \right) \\ &= j \frac{A}{2\pi n} \end{aligned}$$

Now for $n = 0$ we have

$$C_0 = \frac{1}{T} \int_0^T \frac{A}{T} t dt = \frac{A}{2}$$

Finally,

$$f(t) = \frac{A}{2} + j \frac{A}{2\pi} \sum_{\substack{n=-\infty \\ n \neq 0}}^{n=\infty} \frac{1}{n} e^{j n \frac{2\pi}{T} t}$$

P15.5-3

$$\begin{aligned}
 C_n &= \frac{A}{T} \int_{-d/2}^{d/2} e^{-jn\frac{2\pi}{T}t} dt = \frac{A}{T} \left[\frac{e^{-jn\frac{2\pi}{T}t}}{-jn\frac{2\pi}{T}} \right]_{-d/2}^{d/2} = \frac{A}{T} \left(\frac{e^{jn\frac{\pi}{T}d}}{jn\frac{2\pi}{T}} - \frac{e^{-jn\frac{\pi}{T}d}}{jn\frac{2\pi}{T}} \right) \\
 &= \frac{A}{n\pi} \left(\frac{e^{jn\frac{\pi}{T}d} - e^{-jn\frac{\pi}{T}d}}{2j} \right) \\
 &= \frac{A}{n\pi} \sin\left(\frac{n\pi d}{T}\right) \\
 &= \left(\frac{Ad}{T}\right) \frac{\sin\left(\frac{n\pi d}{T}\right)}{\frac{n\pi d}{T}}
 \end{aligned}$$

P15.5-4

$$\widehat{C}_n = \frac{1}{T} \int_{t_0}^{t_0+T} (af(t-t_d) + b) e^{-jn\omega_o t} dt$$

Let $\tau = t - t_d$, then $t = \tau + t_d$.

$$\begin{aligned}
 \widehat{C}_n &= \frac{1}{T} \int_{t_0-t_d}^{t_0+T-t_d} (af(\tau) + b) e^{-jn\omega_o(\tau+t_d)} d\tau \\
 &= \frac{1}{T} \int_{t_0-t_d}^{t_0+T-t_d} (af(\tau) + b) e^{-jn\omega_o\tau} e^{-jn\omega_o t_d} d\tau \\
 &= \frac{e^{-jn\omega_o t_d}}{T} \int_{t_0-t_d}^{t_0+T-t_d} (af(\tau) + b) e^{-jn\omega_o\tau} d\tau \\
 &= \left(a e^{-jn\omega_o t_d} \right) \frac{1}{T} \int_{t_0-t_d}^{t_0+T-t_d} f(\tau) e^{-jn\omega_o\tau} d\tau + \left(e^{-jn\omega_o t_d} \right) \frac{1}{T} \int_{t_0-t_d}^{t_0+T-t_d} b e^{-jn\omega_o\tau} d\tau
 \end{aligned}$$

But $\int_{t_0-t_d}^{t_0+T-t_d} b e^{-jn\omega_o\tau} d\tau = b \left[\frac{e^{-jn\omega_o\tau}}{-jn\omega_o} \right]_{t_0-t_d}^{t_0+T-t_d} = \begin{cases} 0 & n \neq 0 \\ b & = 0 \end{cases}$ so

$$\widehat{C}_0 = a C_0 + b$$

and

$$\widehat{C}_n = a e^{-jn\omega_o t_d} C_n \quad n \neq 0$$

P15.5-5

$$T = 8 \text{ s}, \quad \omega_0 = \frac{2\pi}{T} = \frac{\pi}{4} \text{ rad/s}, \quad C_0 = \text{average value} = \frac{2 \times 2 - 2(1 \times 1)}{8} = \frac{1}{4}$$

The coefficients of the exponential Fourier series are calculated as

$$\begin{aligned} C_n &= \frac{1}{8} \left[\int_{-2}^{-1} -1 \times e^{-j\frac{n\pi}{4}t} dt + \int_{-1}^1 2 \times e^{-j\frac{n\pi}{4}t} dt + \int_1^2 -1 \times e^{-j\frac{n\pi}{4}t} dt \right] \\ &= \frac{1}{8} \left[-1 \times \frac{e^{-j\frac{n\pi}{4}t}}{-j\frac{n\pi}{4}} \Big|_{-2}^{-1} + 2 \times \frac{e^{-j\frac{n\pi}{4}t}}{-j\frac{n\pi}{4}} \Big|_{-1}^1 + (-1) \times \frac{e^{-j\frac{n\pi}{4}t}}{-j\frac{n\pi}{4}} \Big|_1^2 \right] \\ &= \frac{-j}{2n\pi} \left[\left(e^{j\frac{n\pi}{4}} - e^{j\frac{n\pi}{2}} \right) - 2 \left(e^{-j\frac{n\pi}{4}} - e^{-j\frac{n\pi}{4}} \right) + \left(e^{-j\frac{n\pi}{2}} - e^{-j\frac{n\pi}{4}} \right) \right] \end{aligned}$$

and

$$\begin{aligned} C_{-n} &= \frac{1}{8} \left[\int_{-2}^{-1} -1 \times e^{-j\frac{-n\pi}{4}t} dt + \int_{-1}^1 2 \times e^{-j\frac{-n\pi}{4}t} dt + \int_1^2 -1 \times e^{-j\frac{-n\pi}{4}t} dt \right] \\ &= \frac{1}{8} \left[-1 \times \frac{e^{j\frac{n\pi}{4}t}}{j\frac{n\pi}{4}} \Big|_{-2}^{-1} + 2 \times \frac{e^{j\frac{n\pi}{4}t}}{j\frac{n\pi}{4}} \Big|_{-1}^1 + (-1) \times \frac{e^{j\frac{n\pi}{4}t}}{j\frac{n\pi}{4}} \Big|_1^2 \right] \\ &= \frac{j}{2n\pi} \left[\left(e^{-j\frac{n\pi}{4}} - e^{-j\frac{n\pi}{2}} \right) - 2 \left(e^{j\frac{n\pi}{4}} - e^{-j\frac{n\pi}{4}} \right) + \left(e^{j\frac{n\pi}{2}} - e^{j\frac{n\pi}{4}} \right) \right] \\ &= -C_n \end{aligned}$$

The function is represented as

$$f(t) = C_0 + \sum_{n=1}^{\infty} C_n e^{jn\omega_0 t} + \sum_{n=-1}^{-\infty} C_{-n} e^{-jn\omega_0 t}$$

This result can be checked using MATLAB:

```
pi = 3.14159;  
N=100;  
  
T = 8; % period  
t = linspace(0,2*T,200); % time  
c0 = 1/4; % average value  
w0 = 2*pi/T; % fundamental frequency  
  
for n = 1: N  
    C(n) = -j*((exp(+j*n*pi/4)-exp(+j*n*pi/2))-2*(exp(-j*n*pi/4)-  
    exp(+j*n*pi/4)))+(exp(-j*n*pi/2)-exp(-j*n*pi/4)))/(2*pi*n);  
end  
  
for i=1:length(t)  
    f(i)=c0;  
    for n=1:length(C)  
        f(i)=f(i)+C(n)*exp(j*n*w0*t(i))+C(n)*exp(-j*n*w0*t(i));  
    end  
end  
  
plot(t,f,'black');  
xlabel('t, sec');  
ylabel('f(t)');
```

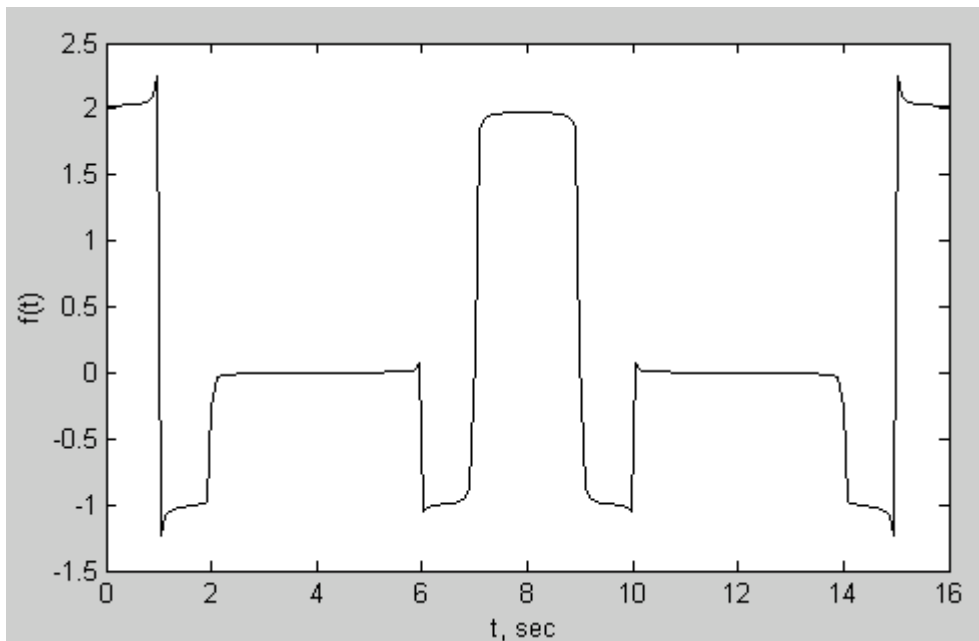

Alternately, this result can be checked using Mathcad:

$$N := 15 \quad n := 1, 2.. N \quad m := 1, 2.. N$$

$$T := 8 \quad \omega := 2 \frac{\pi}{T}$$

$$d := \frac{T}{200} \quad i := 1, 2.. 400 \quad t_i := d \cdot i$$

$$C_n := \frac{\int_{-2}^{-1} -1 \cdot \exp(-j \cdot n \cdot \omega \cdot t) dt + \int_{-1}^1 2 \cdot \exp(-j \cdot n \cdot \omega \cdot t) dt + \int_1^2 -1 \exp(-j \cdot n \cdot \omega \cdot t) dt}{T}$$

$$C_m := \frac{\int_{-2}^{-1} -1 \cdot \exp(j \cdot m \cdot \omega \cdot t) dt + \int_{-1}^1 2 \cdot \exp(j \cdot m \cdot \omega \cdot t) dt + \int_1^2 -1 \exp(j \cdot m \cdot \omega \cdot t) dt}{T}$$

$$f(i) := \sum_{n=1}^N C_n \cdot \exp(j \cdot n \cdot \omega \cdot t_i) + \sum_{m=1}^N C_m \cdot \exp(-1 \cdot j \cdot m \cdot \omega \cdot t_i)$$

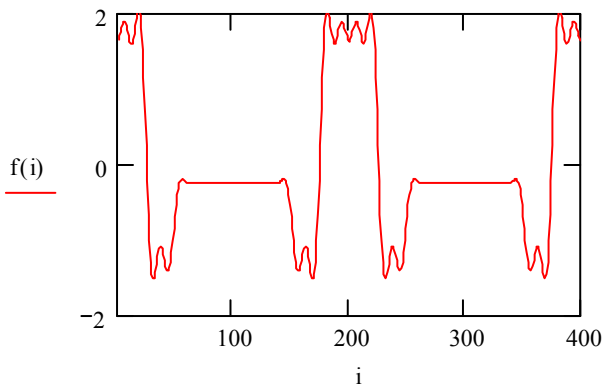

$C_n =$	$C_m =$	$f(i) =$
0.357	0.357	.643
0.477	0.477	.685
0.331	0.331	.745
0	0	.807
0.199	0.199	.856
0.159	0.159	1.88
0.051	0.051	.872
0	0	.831
0.04	0	.767
0.095	0.04	.693
0.09	0.095	.628
0	0.09	.589
0.076	0	.589
0.068	0.076	.633
0.024	0.068	.717
	0.024	.825

P15.5-6

The function shown at right is related to the given function by

$$v(t) = -v_1(t+1) - 6$$

(Multiply by -1 to flip v_1 upside-down; subtract 6 to fix the average value; replace t by $t+1$ to shift to the left by 1 s.)

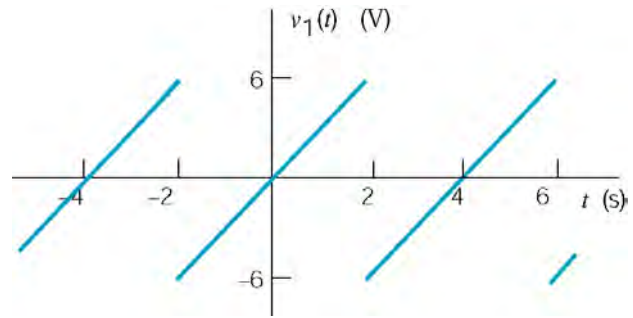

From Table 15.5-1

$$v_1(t) = \sum_{n=-\infty}^{\infty} \frac{jA(-1)^n}{n\pi} e^{jn\omega_0 t} = \sum_{n=-\infty}^{\infty} \frac{j6(-1)^n}{n\pi} e^{jn\frac{\pi}{2}t}$$

Therefore

$$v(t) = -6 - \sum_{n=-\infty}^{\infty} \frac{j6(-1)^n}{n\pi} e^{jn\frac{\pi}{2}(t+1)} = -6 - \sum_{n=-\infty}^{\infty} \left(\frac{j6(-1)^n}{n\pi} e^{jn\frac{\pi}{2}} \right) e^{jn\frac{\pi}{2}t}$$

The coefficients of this series are:

$$C_0 = -6 \quad \text{and} \quad C_n = -\frac{j6(-1)^n}{n\pi} e^{jn\frac{\pi}{2}}$$

This result can be checked using Matlab:

```

pi = 3.14159;
N=100;
A = 6; % amplitude
T = 4; % period
t = linspace(0,2*T,200); % time
c0 = -6; % average value
w0 = 2*pi/T; % fundamental frequency

for n = 1: N
    C(n) = (-j*A*(-1)^n/n/pi)*exp(+j*n*pi/2);
    D(n) = (+j*A*(-1)^n/n/pi)*exp(-j*n*pi/2);
end

for i=1:length(t)
    f(i)=c0;
    for n=1:length(C)
        f(i)=f(i)+C(n)*exp(j*n*w0*t(i))+D(n)*exp(-j*n*w0*t(i));
    end
end

plot(t,f,'black');
xlabel('t, sec');
ylabel('f(t)');
title('p15.5-6')

```

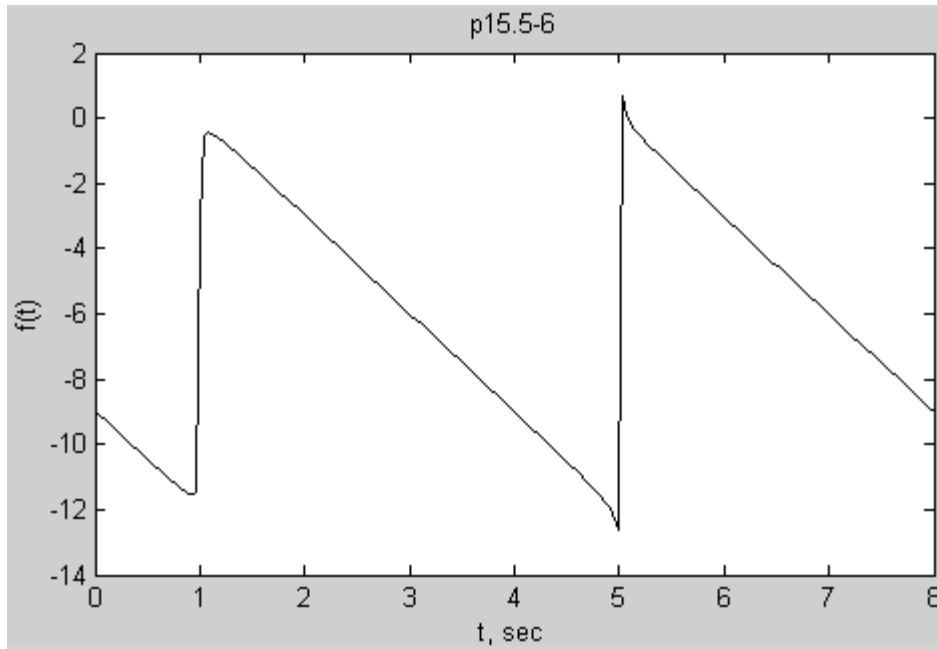

P15.5-7

Represent the function as

$$f(t) = \begin{cases} 1 - e^{-5t} & 0 \leq t \leq 1 \\ e^{-5(t-1)} - e^{-5} & 1 \leq t \leq 2 \end{cases}$$

(Check: $f(0) = 0$, $f(1) = 1 - e^{-5} \approx 1$, $f(2) = e^{-5} - e^{-5} = 0$)

$$T = 2 \text{ s}, \quad \omega_0 = \frac{2\pi}{2} = \pi, \quad \text{also } C_0 = \text{average value} = \frac{1}{2}$$

The coefficients of the exponential Fourier series are calculated as

$$\begin{aligned} C_n &= \frac{1}{2} \left[\int_0^1 (1 - e^{-5t}) e^{-jn\pi t} dt + \int_1^2 (e^{-5(t-1)} - e^{-5}) e^{-jn\pi t} dt \right] \\ &= \frac{1}{2} \left[\left(\int_0^1 e^{-jn\pi t} dt - \int_0^1 e^{-5t} e^{-jn\pi t} dt \right) + \left(e^5 \int_1^2 e^{-(5+jn\pi)t} dt - e^{-5} \int_1^2 e^{-jn\pi t} dt \right) \right] \\ &= \frac{1}{2} \left[\left(\left. \frac{e^{-jn\pi t}}{-jn\pi} \right|_0^1 - \left. \frac{e^{-(5+jn\pi)t}}{-(5+jn\pi)} \right|_0^1 \right) + \left(e^5 \left. \frac{e^{-(5+jn\pi)t}}{-(5+jn\pi)} \right|_1^2 - e^{-5} \left. \frac{e^{-jn\pi t}}{-jn\pi} \right|_1^2 \right) \right] \\ &= \frac{1}{2} \left[\left(\frac{e^{-jn\pi} - 1}{-jn\pi} - \frac{e^{-5} e^{-jn\pi} - 1}{-(5+jn\pi)} \right) + \left(e^5 \frac{e^{-(5+jn\pi)2} - e^{-(5+jn\pi)}}{-(5+jn\pi)} - e^{-5} \frac{e^{-jn\pi 2} - e^{-jn\pi}}{-jn\pi} \right) \right] \\ &= \frac{1}{2} \left[\left(\frac{e^{-jn\pi} - 1}{-jn\pi} - \frac{e^{-5} e^{-jn\pi} - 1}{-(5+jn\pi)} \right) + \left(\frac{e^{-5} e^{-j2n\pi} - e^{-jn\pi}}{-(5+jn\pi)} - e^{-5} \frac{e^{-jn\pi 2} - e^{-jn\pi}}{-jn\pi} \right) \right] \\ &= \frac{1}{2} \left[\left(\frac{(-1)^n - 1}{-jn\pi} - \frac{e^{-5} (-1)^n - 1}{-(5+jn\pi)} \right) + \left(\frac{e^{-5} - (-1)^n}{-(5+jn\pi)} - e^{-5} \frac{1 - (-1)^n}{-jn\pi} \right) \right] \end{aligned}$$

The terms that include the factor $e^{-5} = 0.00674$ are small and can be ignored.

$$\begin{aligned} C_n &= \frac{1}{2} \left[\left(\frac{(-1)^n - 1}{-jn\pi} - \frac{-1}{-(5+jn\pi)} \right) + \left(\frac{-(-1)^n}{-(5+jn\pi)} \right) \right] \\ &= \begin{cases} \frac{1}{jn\pi} - \frac{1}{5+jn\pi} & \text{odd } n \\ 0 & \text{even } n \end{cases} \\ &= \begin{cases} \frac{5}{(jn\pi)(5+jn\pi)} & \text{odd } n \\ 0 & \text{even } n \end{cases} \end{aligned}$$

This result can be checked using Matlab:

```
pi = 3.14159;  
N=101;  
T = 2; % period  
t = linspace(0,2*T,200); % time  
c0 = 0.5; % average value  
w0 = 2*pi/T; % fundamental frequency  
  
for n = 1:2:N  
    if n == 2*(n/2)  
        C(n) = 5/((+j*pi*n)*(5+j*pi*n));  
        D(n) = 5/((-j*pi*n)*(5-j*pi*n));  
    else  
        C(n)=0;  
        D(n)=0  
    end  
end  
  
for i=1:length(t)  
    f(i)=c0;  
    for n=1:length(C)  
        f(i)=f(i)+C(n)*exp(j*n*w0*t(i))+D(n)*exp(-j*n*w0*t(i));  
    end  
end  
  
plot(t,f,'black');  
xlabel('t, sec');  
ylabel('f(t)');  
title('p15.5-7')
```

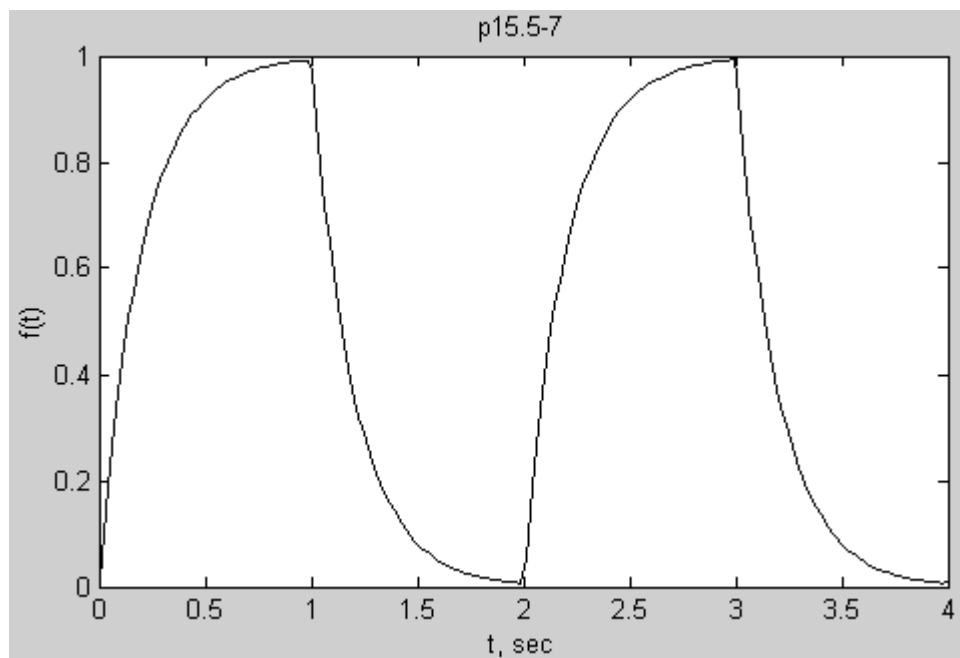

Section 15-6: The Fourier Spectrum

P15.6-1

Average value = 0 $\Rightarrow a_0 = 0$

$$\text{half-wave symmetry} \Rightarrow \begin{cases} a_n = \frac{4}{T} \int_0^{T/2} \underbrace{\left(-\frac{4A}{T}t\right)}_{f(t)} \cos\left(n\frac{2\pi}{T}t\right) dt = -\frac{4A}{n^2\pi^2} (\cos(n\pi) - 1) \\ b_n = \frac{4}{T} \int_0^{T/2} \left(-\frac{4A}{T}t\right) \sin\left(n\frac{2\pi}{T}t\right) dt = -\frac{2A}{n\pi} (1 - \cos(n\pi)) \end{cases}$$

$$n \quad C_n = \sqrt{a_n^2 + b_n^2} \quad \theta_n = \tan^{-1}\left(\frac{b_n}{a_n}\right)$$

1	$1.509 \cdot A$	-57.5°
2	0	0
3	$0.434 \cdot A$	-78.0°
4	0	0
5	$0.257 \cdot A$	-82.7°
6	0	0
7	$0.183 \cdot A$	-84.8°

P15.6-2

Mathcad spreadsheet (p15_6_2.mcd):

$$N := 100 \quad n := 1, 2.. N \quad T := 32 \quad \omega_0 := 2 \frac{\pi}{T}$$

Calculate the coefficients of the exponential Fourier series:

$$C_{1n} := \frac{4}{T} \int_{3 \cdot \frac{T}{16}}^{\frac{T}{4}} \left(16 \frac{t}{T} - 3 \right) \exp(-j \cdot n \cdot \omega_0 \cdot t) dt$$

$$C_{2n} := \frac{4}{T} \int_{\frac{T}{4}}^{\frac{T}{2}} \sin\left(\frac{2 \cdot \pi}{T} \cdot t\right) \exp(-j \cdot n \cdot \omega_0 \cdot t) dt$$

$$C_{3n} := \frac{4}{T} \int_{11 \cdot \frac{T}{16}}^{\frac{3 \cdot T}{4}} \left(11 - \frac{16t}{T} \right) \exp(-j \cdot n \cdot \omega_0 \cdot t) dt$$

$$C_{4n} := \frac{4}{T} \int_{3 \cdot \frac{T}{4}}^T \sin\left(\frac{2 \cdot \pi}{T} \cdot t\right) \exp(-j \cdot n \cdot \omega_0 \cdot t) dt$$

$$C_n := C_{1n} + C_{2n} + C_{3n} + C_{4n}$$

Check: Plot the function using it's exponential Fourier series:

$$d := \frac{T}{200} \quad i := 1, 2.. 400 \quad t_i := d \cdot i \quad f(i) := \sum_{n=1}^N C_n \cdot \exp(j \cdot n \cdot \omega_0 \cdot t_i) + \sum_{n=1}^N \overline{C_n} \cdot \exp(-j \cdot n \cdot \omega_0 \cdot t_i)$$

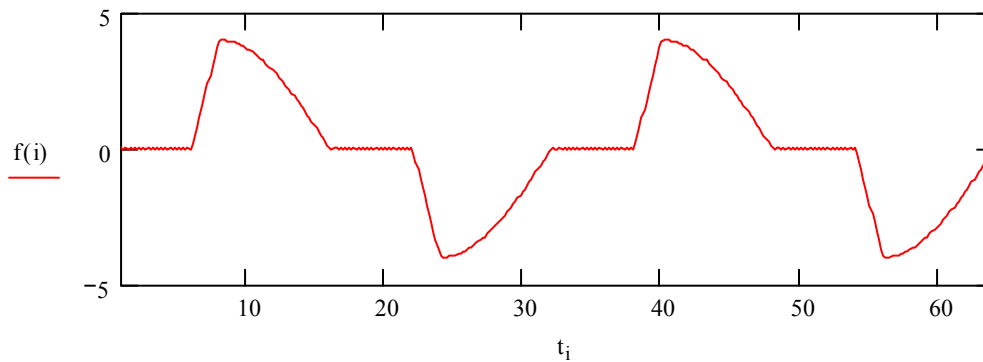

Plot the magnitude spectrum:

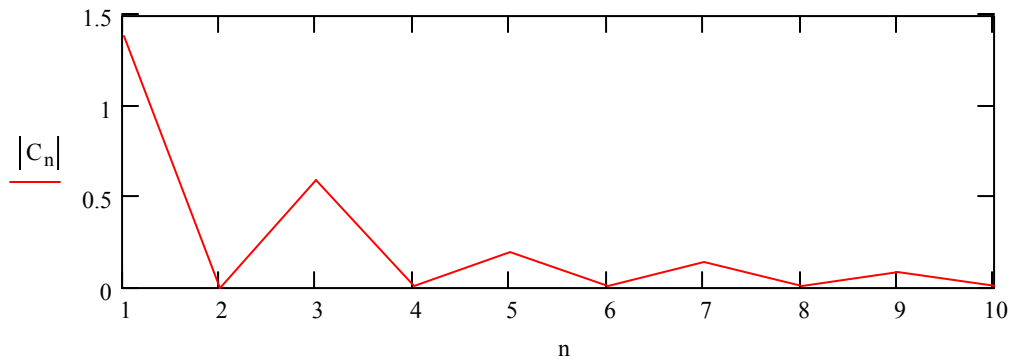

That's not a very nice plot. Here are the values of the coefficients:

$ C_n =$	$\arg(C_n) \cdot \frac{180}{\pi} =$
1.385	-115.853
0	-90
0.589	22.197
0	-24.775
0.195	-113.34
0	106.837
0.139	66.392
0	-78.232
0.082	-69.062
0	-48.814
0.039	109.584
0	90.415
0.027	-25.598
0	78.14
$1.226 \cdot 10^{-3}$	63.432
0	163.724

P15.6-3

Use Euler's formula to convert the trigonometric series of the input to an exponential series:

$$\begin{aligned} v_i(t) &= 10 \cos t + 10 \cos 10t + 10 \cos 100t \text{ V} \\ &= 10 \frac{e^{-t} + e^t}{2} + 10 \frac{e^{-10t} + e^{10t}}{2} + 10 \frac{e^{-100t} + e^{100t}}{2} \\ &= 5e^{-100t} + 5e^{-10t} + 5e^{-t} + 5e^t + 5e^{10t} + 5e^{100t} \end{aligned}$$

The corresponding Fourier spectrum is:

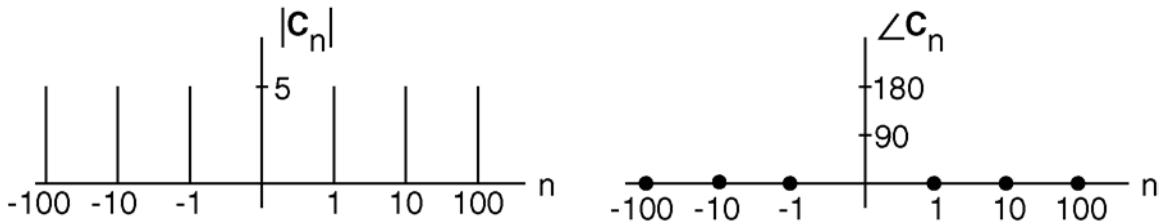

Evaluating the network function at the frequencies of the input:

ω , rad/s	$ \mathbf{H}(\omega) $	$\angle \mathbf{H}(\omega)$, °
1	1.923	-23
10	0.400	-127
100	0.005	-174

Using superposition:

$$v_o(t) = 19.23 \cos(t - 23^\circ) + 4.0 \cos(10t - 127^\circ) + 0.05 \cos(100t - 174^\circ) \text{ V}$$

Use Euler's formula to convert the trigonometric series of the output to an exponential series:

$$\begin{aligned} v_o(t) &= 19.23 \frac{e^{j(t-23^\circ)} + e^{-j(t-23^\circ)}}{2} + 4.0 \frac{e^{j(10t-127^\circ)} + e^{-j(10t-127^\circ)}}{2} + 0.05 \frac{e^{j(100t-174^\circ)} + e^{-j(100t-174^\circ)}}{2} \text{ V} \\ &= 19.23e^{j174^\circ} e^{-jt} + 4.0 e^{j127^\circ} e^{-j10t} + 19.23e^{j23^\circ} e^{-jt} + 19.23e^{-j23^\circ} e^{jt} + 4.0 e^{-j127^\circ} e^{j10t} + 19.23e^{-j174^\circ} e^{jt} \end{aligned}$$

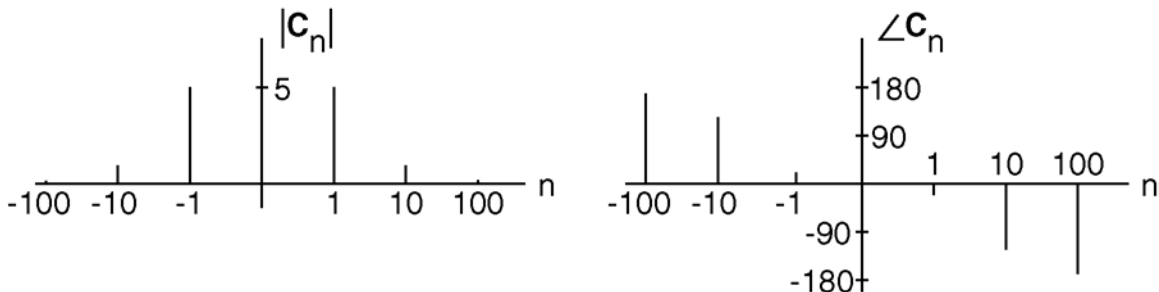

P15.6-4

$$T = 1 \text{ s}, \quad \omega_0 = \frac{2\pi}{T} = 2\pi \text{ rad/s}, \quad C_0 = \frac{1}{2}$$

$$f(t) = 1 - t \quad \text{when } 0 \leq t < 1 \text{ s}$$

The coefficients of the exponential Fourier series are given by

$$C_n = \frac{1}{1} \int_0^1 (1-t) e^{-j2\pi n t} dt = \int_0^1 e^{-j2\pi n t} dt - \int_0^1 t e^{-j2\pi n t} dt$$

Evaluate the first integral as

$$\int_0^1 e^{-j2\pi n t} dt = \left. \frac{e^{-j2\pi n t}}{-j2\pi n} \right|_0^1 = \frac{e^{-j2\pi n} - 1}{-j2\pi n} = 0$$

To evaluate the second integral, recall the formula for integrating by parts:

$\int_{t_1}^{t_2} u dv = uv \Big|_{t_1}^{t_2} - \int_{t_1}^{t_2} v du$. Take $u = t$ and $dv = e^{-j2\pi n t} dt$. Then

$$\begin{aligned} \int_0^1 t e^{-j2\pi n t} dt &= \left. \frac{t e^{-j2\pi n t}}{-j2\pi n} \right|_0^1 + \frac{1}{j2\pi n} \int_0^1 e^{-j2\pi n t} dt \\ &= \frac{e^{-j2\pi n}}{-j2\pi n} + \left. \frac{e^{-j2\pi n t}}{(j2\pi n)^2} \right|_0^1 = \frac{e^{-j2\pi n}}{-j2\pi n} + \frac{e^{-j2\pi n} - 1}{(j2\pi n)^2} = j \frac{1}{2\pi n} \end{aligned}$$

Therefore

$$C_n = \begin{cases} \frac{1}{2} & n = 0 \\ \frac{-j}{2\pi n} & n \neq 0 \end{cases}$$

To check these coefficients, represent the function by its Fourier series:

$$f(t) = \frac{1}{2} + \sum_{n=1}^{\infty} \left(\frac{-j}{2\pi n} e^{j2\pi n t} + \frac{j}{2\pi n} e^{-j2\pi n t} \right)$$

Next, use Matlab to plot the function from its Fourier series (p15_6_4check.m):

```
pi = 3.14159;
N=20;

T = 1; % period
t = linspace(0, 2*T, 200); % time
```

```

c0 = 1/2;           % average value
w0 = 2*pi/T;       % fundamental frequency

for n = 1: N
    C(n) = -j/(2*pi*n);
end

for i=1:length(t)
    f(i)=c0;
    for n=1:length(C)
        f(i)=f(i)+C(n)*exp(j*n*w0*t(i))-C(n)*exp(-j*n*w0*t(i));
    end
end

plot(t,f,'black');
xlabel('t, sec');
ylabel('f(t)');

```

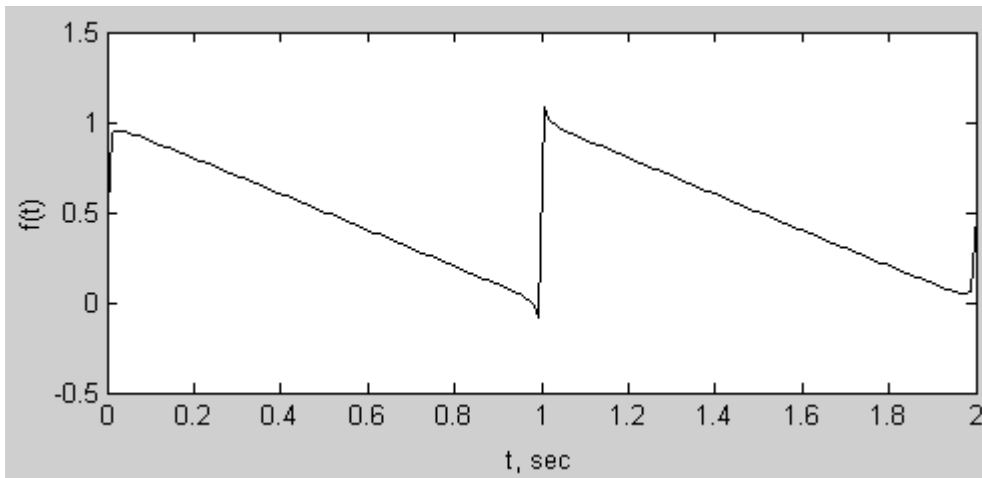

This plot agrees with the given function, so we are confident that the coefficients are correct. The magnitudes of the coefficients of the exponential Fourier series are:

$$|C_n| = \begin{cases} \frac{1}{2} & n = 0 \\ \frac{1}{2\pi n} & n \neq 0 \end{cases}$$

Finally, use the “stemplot” in Matlab to plot the Fourier spectrum (p15_6_4spectrum.m):

```

pi = 3.14159;
N=20;
n = linspace(-N,N,2*N+1);

Cn = abs(1/(2*pi)./n); % Division by 0 when n=0 causes Cn(N+1)=
NaN.

```

```
Cn(N+1)=1/2;          % Fix Cn(N+1); C0=1/2

% Plot the spectrum using a stem plot
stem(n,Cn,'-*k');
xlabel('n');
ylabel('|Cn|');
```

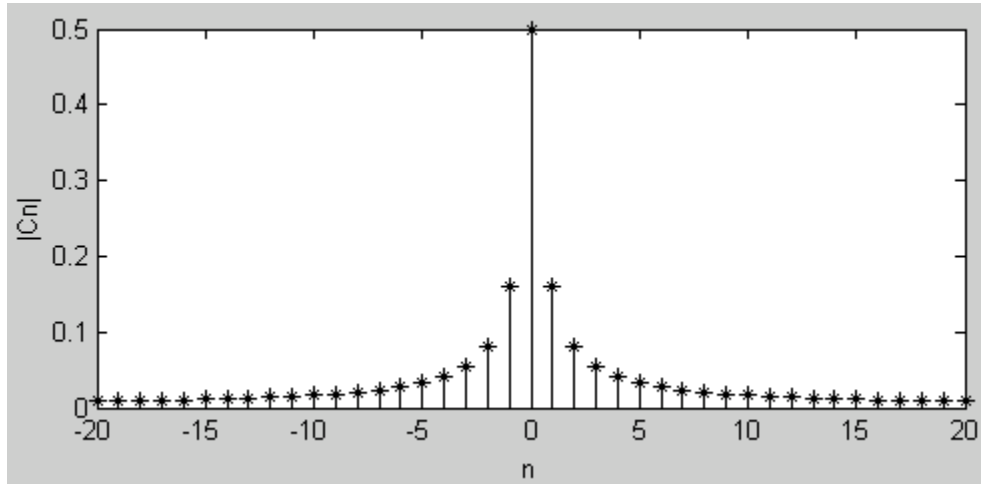

Section 15.8: Circuits and Fourier Series

P15.8-1

The network function of the circuit is:

$$\mathbf{H}(\omega) = \frac{\mathbf{V}_o(\omega)}{\mathbf{V}_i(\omega)} = \frac{\frac{100}{j\omega}}{10 + \frac{100}{j\omega}} = \frac{1}{1 + j\frac{\omega}{10}}$$

Evaluating the network function at the harmonic frequencies:

$$\mathbf{H}\left(n\frac{\pi}{2}\right) = \frac{1}{1 + j\frac{n\pi}{20}} = \frac{20}{20 + jn\pi} = \frac{20}{\sqrt{400 + n^2\pi^2}} \angle -\tan^{-1}\left(\frac{n\pi}{20}\right)$$

From problem 15.4-2, the Fourier series of the input voltage is

$$v_c(t) = -6 + \sum_{n=1}^{\infty} \frac{12}{n\pi} \sin\left(n\frac{\pi}{2}t - n\frac{\pi}{2}\right)$$

Using superposition, the Fourier series of the output voltage is

$$v_o(t) = -6 + \sum_{n=1}^{\infty} \frac{240}{n\pi\sqrt{400 + n^2\pi^2}} \sin\left(n\frac{\pi}{2}t - \left(n\frac{\pi}{2} + \tan^{-1}\left(\frac{n\pi}{20}\right)\right)\right)$$

P15.8-2

The network function of the circuit is:

$$\begin{aligned} \mathbf{H}(\omega) &= \frac{\mathbf{V}_o(\omega)}{\mathbf{V}_i(\omega)} = -\frac{\frac{R_2}{1 + j\omega C_2 R_2}}{R_1 + \frac{1}{j\omega C_1}} = -\frac{j\omega C_1 R_2}{(1 + j\omega C_1 R_1)(1 + j\omega C_2 R_2)} \\ &= -\frac{j\omega(10^{-6})(2000)}{(1 + j\omega(10^{-6})(1000))(1 + j\omega(10^{-6})(2000))} \\ &= -\frac{j\frac{\omega}{500}}{\left(1 + j\frac{\omega}{1000}\right)\left(1 + j\frac{\omega}{500}\right)} \end{aligned}$$

Evaluating the network function at the harmonic frequencies:

$$\mathbf{H}\left(n\frac{1000\pi}{3}\right) = -\frac{jn\frac{2\pi}{3}}{\left(1+jn\frac{\pi}{3}\right)\left(1+jn\frac{2\pi}{3}\right)}$$

From problem 15.4-4, the Fourier series of the input voltage is

$$v_b(t) = -\frac{1}{2} + \sum_{n=1}^{\infty} \frac{18}{n^2\pi^2} \left(1 - \cos\left(\frac{n\pi}{3}\right)\right) \cos\left(n\frac{1000\pi}{3}t - n\frac{2\pi}{3}\right)$$

Using superposition, the Fourier series of the output voltage is

$$v_b(t) = -\frac{1}{2} + \sum_{n=1}^{\infty} \frac{18 \times \left| \mathbf{H}\left(n\frac{1000\pi}{3}\right) \right|}{n^2\pi^2} \left(1 - \cos\left(\frac{n\pi}{3}\right)\right) \cos\left(n\frac{1000\pi}{3}t - n\frac{2\pi}{3} + \angle \mathbf{H}\left(n\frac{1000\pi}{3}\right)\right)$$

P15.8-3

$$\mathbf{H}(\omega) = \frac{\mathbf{V}_o(\omega)}{\mathbf{V}_i(\omega)} = \frac{H_o}{1 + j\frac{\omega}{p}}$$

When $\omega = 0$ (dc)

$$-5 = -\frac{R}{10^4}(2) \Rightarrow R = 25 \text{ k}\Omega$$

When $\omega = 100$ rad/s

$$\begin{aligned} 135^\circ = \angle \mathbf{H}(\omega) &= 180^\circ - \tan^{-1}(\omega CR) \Rightarrow \tan(45^\circ) = (100)C(25000) \\ &\Rightarrow C = 0.4 \text{ }\mu\text{F} \end{aligned}$$

$$c_4 = (5) |\mathbf{H}(400)| = (5) \left| \frac{\frac{25000}{10^4}}{1 + j(400)(0.4 \times 10^{-6})(25000)} \right| = 3.032$$

$$\theta_4 = 45^\circ + \angle \mathbf{H}(400) = 45^\circ + 180^\circ - \tan^{-1}(400 \times 0.4 \times 10^{-6} \times 25000) = 149^\circ$$

P15.8-4When $\omega = 0$ (dc)

$$5 = H_o(2) \Rightarrow H_o = 2.5 \text{ V/V}$$

When $\omega = 25$ rad/s

$$-45^\circ = \angle \mathbf{H}(\omega) = -\tan^{-1}\left(\frac{\omega}{p}\right) \Rightarrow \tan(45^\circ) = \frac{25}{p} \Rightarrow p = 25 \text{ rad/s}$$

$$c_4 = (5)|\mathbf{H}(100)| = (5)\left|\frac{2.5}{1 + j\frac{100}{25}}\right| = 3.03$$

$$\theta_4 = 45^\circ + \angle \mathbf{H}(100) = 45^\circ - \tan^{-1}\left(\frac{100}{25}\right) = -31^\circ$$

P15.8-5

$$\mathbf{H}(\omega) = \frac{\mathbf{V}_o(\omega)}{\mathbf{V}_i(\omega)} = \frac{R_2}{R_1 + R_2 + j\omega C R_1 R_2}$$

When $\omega = 0$ (dc)

$$\frac{R_2}{R_1 + R_2} = \frac{3.75}{6} \Rightarrow R_1 = \left(\frac{2.25}{3.75}\right)R_2 = \left(\frac{2.25}{3.75}\right)(500) = 300 \Omega$$

When $\omega = 1000$ rad/s

$$\begin{aligned} -20.5^\circ = \angle \mathbf{H}(\omega) &= -\tan^{-1}\left(\omega C \frac{R_1 R_2}{R_1 + R_2}\right) \Rightarrow \tan(20.5^\circ) = (1000)C \left(\frac{(300)(500)}{800}\right) \\ &\Rightarrow C = 2 \mu\text{F} \end{aligned}$$

$$c_3 \angle \theta_3 = \left(\frac{500}{800 + j(3000)(2 \times 10^{-6})(500)(300)}\right)(5 \angle 45^\circ) = 2.076 \angle -3.4^\circ$$

P15.8-6

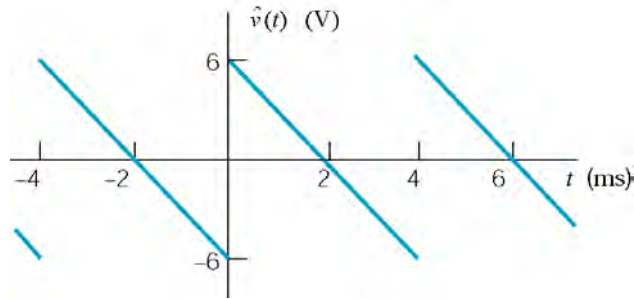

Rather than find the Fourier Series of $v(t)$ directly, consider the signal $\hat{v}(t)$ shown above. These two signals are related by

$$v(t) = \hat{v}(t-1) - 6$$

since $v(t)$ is delayed by 1 ms and shifted down by 6 V.

The Fourier series of $\hat{v}(t)$ is obtained as follows:

$$T = 4 \text{ ms} \Rightarrow \omega_0 = \frac{2\pi \text{ radians}}{4 \text{ ms}} = \frac{\pi}{2} \text{ rad/ms}$$

$$\hat{a}_n = 0 \text{ because the average value of } \hat{v}(t) = 0$$

$$\hat{b}_n = \frac{1}{2} \int_0^4 (6-3t) \sin\left(n\frac{\pi}{2}t\right) dt \text{ because } \hat{v}(t) \text{ is an odd function.}$$

$$= 3 \int_0^4 \sin\left(n\frac{\pi}{2}t\right) dt - \frac{3}{2} \int_0^4 t \sin\left(n\frac{\pi}{2}t\right) dt$$

$$= 3 \frac{-\cos\left(n\frac{\pi}{2}t\right)}{n\frac{\pi}{2}} \Big|_0^4 - \frac{3}{2} \left[\left(\frac{1}{n^2\pi^2} \right) \sin\left(n\frac{\pi}{2}t\right) - \left(\frac{n\pi}{2}t \right) \cos\left(n\frac{\pi}{2}t\right) \right] \Big|_0^4$$

$$= \frac{6}{n\pi} (-1 + \cos(2n\pi)) - \frac{6}{n^2\pi^2} ((\sin(2n\pi) - 0) - (2n\pi - \cos(2\pi) - 0)) = \frac{12}{n\pi}$$

Finally,

$$\hat{v}(t) = \sum_{n=1}^{\infty} \frac{12}{n\pi} \sin n\frac{\pi}{2}t$$

The Fourier series of $v(t)$ is obtained from the Fourier series of $\hat{v}(t)$ as follows:

$$v(t) = -6 + \sum_{n=1}^{\infty} \frac{12}{n\pi} \sin n\frac{\pi}{2}(t-1) = -6 + \sum_{n=1}^{\infty} \frac{12}{n\pi} \sin\left(n\frac{\pi}{2}t - n\frac{\pi}{2}\right)$$

where t is in ms. Equivalently,

$$v(t) = -6 + \frac{12}{\pi} \sum_{n=1}^{\infty} \frac{1}{n} \sin\left(n\frac{\pi}{2}10^3 t - n\frac{\pi}{2}\right)$$

where t is in s.

Next, the transfer function of the circuit is $H(s) = \frac{R}{\frac{1}{Cs} + Ls + R} = \frac{\frac{R}{L}s}{s^2 + \frac{R}{L}s + \frac{1}{LC}}$.

The network function of the circuit is $\mathbf{H}(\omega) = \frac{j\omega\frac{R}{L}}{\left(\frac{1}{LC} - \omega^2\right) + j\omega\frac{R}{L}} = \frac{10^4 j\omega}{(10^8 - \omega^2) + 10^4 j\omega}$.

We see that $\mathbf{H}(0) = 0$ and

$$\mathbf{H}(n\omega_0) = \mathbf{H}\left(n\frac{\pi}{2}10^3\right) = \frac{j20n\pi}{(400 - n^2\pi^2) + j20n\pi} = \frac{1}{\sqrt{(400 - n^2\pi^2)^2 + 400n^2\pi^2}} e^{j\left(90 - \tan^{-1}\frac{20n\pi}{400 - n^2\pi^2}\right)}$$

Finally,

$$v_0(t) = \frac{12}{\pi} \sum_{n=1}^{\infty} \frac{\sin\left(n\frac{\pi}{2}10^3 t - n\frac{\pi}{2} + 90^\circ - \tan^{-1}\left(\frac{20n\pi}{400 - n^2\pi^2}\right)\right)}{n\sqrt{(400 - n^2\pi^2)^2 + 400n^2\pi^2}}$$

P15.8-7

Rather than find the Fourier Series of $v(t)$ directly, consider the signal $\hat{v}(t)$ shown below.

These two signals are related by $v(t) = \hat{v}(t-2) - 1$

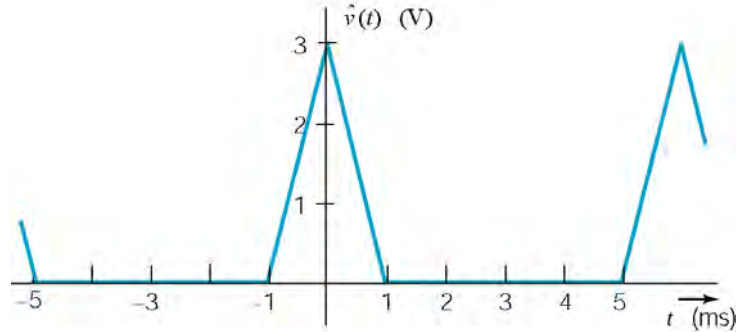

Let's calculate the Fourier Series of $\hat{v}(t)$, taking advantage of its symmetry.

$$T = 6 \text{ ms} \Rightarrow \omega_0 = \frac{2\pi \text{ rad}}{6 \text{ ms}} = \frac{\pi}{3} \text{ rad/ms}$$

$$a_0 = \text{average value of } \hat{v}(t) = \frac{3.2}{6} = \frac{1}{2} \text{ V}$$

$$b_n = 0 \text{ because } \hat{v}(t) \text{ is an even function}$$

$$a_n = 2 \left(\frac{2}{6} \int_0^1 (3-3t) \cos n \frac{\pi}{3} t dt \right)$$

$$a_n = 2 \int_0^1 \cos n \frac{\pi}{3} t dt - 2 \int_0^1 t \cos n \frac{\pi}{3} t dt$$

$$= 2 \left[\frac{\sin n \frac{\pi}{3}}{n \frac{\pi}{3}} - \frac{1}{n^2 \pi^2} \left(\cos n \frac{\pi}{3} t + n \frac{\pi}{3} t \sin n \frac{\pi}{3} t \right) \right]_0^1$$

$$= \frac{6}{n\pi} \sin n \frac{\pi}{3} - \left(\frac{18}{n^2 \pi^2} \left(\cos n \frac{\pi}{3} - 1 \right) + \frac{6}{n\pi} \sin n \frac{\pi}{3} \right) = -\frac{18}{n^2 \pi^2} \left(\cos n \frac{\pi}{3} - 1 \right)$$

so

$$\hat{v}(t) = \frac{1}{2} + \sum_{n=1}^{\infty} \frac{18}{n^2 \pi^2} \left(1 - \cos n \frac{\pi}{3} \right) \cos n \frac{\pi}{3} t$$

$$v(t) = \hat{v}(t-2) - 1 = -\frac{1}{2} + \sum_{n=1}^{\infty} \frac{18}{n^2 \pi^2} \left(1 - \cos \frac{n\pi}{3} \right) \cos \left(n \frac{\pi}{3} t - n \frac{2\pi}{3} \right)$$

where t is in ms. Equivalently,

$$v(t) = -\frac{1}{2} + \sum_{n=1}^{\infty} \frac{18}{n^2 \pi^2} \left(1 - \cos \frac{n\pi}{3}\right) \cos \left(n \frac{\pi}{3} 10^3 t - n \frac{2\pi}{3}\right)$$

where t is in s.

The network function of the circuit is:

$$\mathbf{H}(\omega) = \frac{-\frac{R_2}{1+j\omega C_2 R_2}}{R_1 + \frac{1}{j\omega C_1}} = \frac{j\omega C_1 R_2}{(1+j\omega R_1 C_1)(1+j\omega R_2 C_2)}$$

Evaluate the network function at the harmonic frequencies of the input to get.

$$\mathbf{H}(n\omega_0) = \mathbf{H}\left(n \frac{\pi}{3} 10^3\right) = \frac{-jn \frac{\pi}{3}}{\left(1+jn \frac{\pi}{3}\right)\left(1+jn \frac{2\pi}{3}\right)}$$

The gain and phase shift are

$$|\mathbf{H}(n\omega_0)| = \frac{n \frac{\pi}{3}}{\sqrt{\left(1+\frac{n^2 \pi^2}{9}\right)\left(1+\frac{4n^2 \pi^2}{9}\right)}} = \frac{n\pi}{\sqrt{(9+n^2 \pi^2)(9+4n^2 \pi^2)}}$$

$$\angle \mathbf{H}(n\omega_0) = -90^\circ - \left(\tan^{-1} n \frac{\pi}{3} + \tan^{-1} n \frac{2\pi}{3}\right)$$

The output voltage is

$$v_0(t) = \sum_{n=1}^{\infty} \frac{18 \left(1 - \cos \frac{n\pi}{3}\right) \cos \left(n \frac{\pi}{3} 10^3 t - n \frac{2\pi}{3} - 90^\circ - \tan^{-1} n \frac{\pi}{3} - \tan^{-1} n \frac{2\pi}{3}\right)}{n^2 \pi^2 \sqrt{(9+n^2 \pi^2)(9+4n^2 \pi^2)}}$$

At $t = 4 \text{ ms} = 0.004 \text{ s}$

$$v_0(.004) = \sum_{n=1}^{\infty} \frac{18 \left(1 - \cos \frac{n\pi}{3}\right) \cos \left(n \frac{4\pi}{3} - n \frac{2\pi}{3} - 90^\circ - \tan^{-1} n \frac{\pi}{3} - \tan^{-1} n \frac{2\pi}{3}\right)}{n^2 \pi^2 \sqrt{(9+n^2 \pi^2)(9+4n^2 \pi^2)}}$$

Section 15.9 The Fourier Transform

P15.9-1

Let $g(t) = e^{-at}u(t) - e^{at}u(-t)$. Notice that $f(t) = \lim_{a \rightarrow 0} g(t)$. Next

$$\begin{aligned} G(\omega) &= \int_0^{\infty} e^{-at} e^{-j\omega t} dt - \int_{-\infty}^0 e^{at} e^{-j\omega t} dt = \frac{e^{-(a+j\omega)t}}{-(a+j\omega)} \Big|_0^{\infty} - \frac{e^{(a-j\omega)t}}{(a-j\omega)} \Big|_{-\infty}^0 \\ &= \left(0 - \frac{1}{-(a+j\omega)} \right) - \left(\frac{1}{(a-j\omega)} - 0 \right) = \frac{-2j\omega}{a^2 + \omega^2} \end{aligned}$$

Finally $F(\omega) = \lim_{a \rightarrow 0} G(\omega) = \lim_{a \rightarrow 0} \frac{-2j\omega}{a^2 + \omega^2} = \frac{2}{j\omega}$

P15.9-2

$$F(\omega) = \int_{-\infty}^{\infty} A e^{-at} u(t) e^{-j\omega t} dt = \int_0^{\infty} A e^{-at} e^{-j\omega t} dt = \frac{A e^{-(a+j\omega)t}}{-(a+j\omega)} \Big|_0^{\infty} = 0 - \frac{A}{-(a+j\omega)} = \frac{A}{a+j\omega}$$

P15.9-3

First notice that

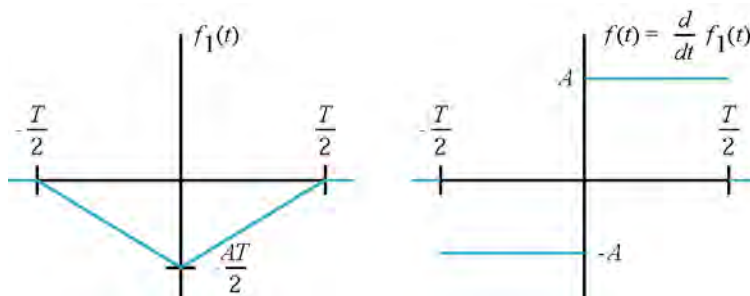

Then, from line 6 of Table 15.10-2: $\mathcal{F}\{f_1(t)\} = \left(-\frac{AT}{2}\right)\left(\frac{T}{2}\right) \text{Sa}^2\left(\frac{\omega T}{4}\right) = \left(-\frac{AT^2}{4}\right) \text{Sa}^2\left(\frac{\omega T}{4}\right)$

From line 7 of Table 15.10-2: $\mathcal{F}\{f(t)\} = \mathcal{F}\left\{\frac{d}{dt} f_1(t)\right\} = j\omega \mathcal{F}\{f_1(t)\} = -j\omega \frac{AT^2}{4} \text{Sa}^2\left(\frac{\omega T}{4}\right)$

This can be written as: $\mathcal{F}\{f(t)\} = -j\omega \frac{AT^2}{4} \frac{\sin^2\left(\frac{\omega T}{4}\right)}{\left(\frac{\omega T}{4}\right)^2} = \frac{4A}{j\omega} \sin^2\left(\frac{\omega T}{4}\right)$

P15.9-4

First notice that: $\mathcal{F}^{-1}\{\delta(\omega - \omega_0)\} = \frac{1}{2\pi} \int_{-\infty}^{\infty} \delta(\omega - \omega_0) e^{-j\omega t} d\omega = \frac{1}{2\pi} e^{-j\omega_0 t}$

Therefore $\mathcal{F}\{e^{-j\omega_0 t}\} = 2\pi\delta(\omega - \omega_0)$. Next, $10 \cos 50t = 5 e^{j50t} + 5 e^{-j50t}$.

Therefore $\mathcal{F}\{10 \cos 50t\} = \mathcal{F}\{5 e^{j50t}\} + \mathcal{F}\{5 e^{-j50t}\} = 10\pi\delta(\omega - 50) + 10\pi\delta(\omega + 50)$.

P15.9-5

$$\begin{aligned} F(\omega) &= -2 \int_1^2 e^{-j\omega t} dt = \left. \frac{-2e^{-j\omega t}}{-j\omega} \right|_1^2 = \frac{2}{j\omega} (e^{-j2\omega} - e^{-j\omega}) = \frac{2}{j\omega} ((\cos 2\omega - j \sin 2\omega) - (\cos \omega - j \sin \omega)) \\ &= \frac{2j}{\omega} (\cos \omega - \cos 2\omega) + \frac{2}{\omega} (\sin \omega - \sin 2\omega) \end{aligned}$$

P15.9-6

$$\begin{aligned} F(\omega) &= \int_0^B \frac{A}{B} t e^{-j\omega t} dt = \frac{A}{B} \left[\frac{e^{-j\omega t}}{(-j\omega)^2} (-j\omega t - 1) \right]_0^B = \frac{A}{B} \left[\frac{e^{-j\omega B}}{-\omega^2} (j\omega B - 1) - \frac{1}{\omega^2} \right] \\ &= \frac{A}{B} \left[\frac{-B e^{-j\omega B}}{j\omega} + \frac{e^{-j\omega B}}{\omega^2} - \frac{1}{\omega^2} \right] \end{aligned}$$

P15.9-7

$$\begin{aligned} F(\omega) &= \int_{-2}^2 e^{-j\omega t} dt - \int_{-1}^1 e^{-j\omega t} dt = \left. \frac{e^{-j\omega t}}{-j\omega} \right|_{-2}^2 - \left. \frac{e^{-j\omega t}}{-j\omega} \right|_{-1}^1 = \frac{1}{j\omega} (e^{j2\omega} - e^{-j2\omega}) - \frac{1}{j\omega} (e^{j\omega} - e^{-j\omega}) \\ &= \frac{2}{\omega} (\sin 2\omega - \sin \omega) \end{aligned}$$

P15.12-1

$$i_s(t) = 40 \operatorname{signum}(t)$$

$$I_s(\omega) = 40 \left(\frac{2}{j\omega} \right) = \frac{80}{j\omega}$$

$$H(\omega) = \frac{I(\omega)}{I_s(\omega)} = \frac{1}{4 + j\omega}$$

$$I(\omega) = H(\omega) I_s(\omega) = \frac{1}{4 + j\omega} \times \frac{80}{j\omega} = \frac{20}{j\omega} - \frac{20}{4 + j\omega}$$

$$\therefore i(t) = 10 \operatorname{signum}(t) - 20 e^{-4t} u(t)$$

P15.12-2

$$i_s(t) = 100 \cos 3t \text{ A}$$

$$I_s(\omega) = 100\pi [\delta(\omega - 3) + \delta(\omega + 3)]$$

$$H(\omega) = \frac{I(\omega)}{I_s(\omega)} = \frac{1}{4 + j\omega}$$

$$I(\omega) = 100\pi \left[\frac{\delta(\omega - 3) + \delta(\omega + 3)}{4 + j\omega} \right]$$

$$\begin{aligned} i(t) &= \frac{100\pi}{2\pi} \int_{-\infty}^{\infty} \left[\frac{\delta(\omega - 3) + \delta(\omega + 3)}{4 + j\omega} \right] e^{j\omega t} d\omega = 50 \left[\frac{e^{-j3t}}{4 - j3} + \frac{e^{j3t}}{4 + j3} \right] \\ &= 10 \left[e^{-j(3t-36.9)} + e^{j(3t-36.9)} \right] \\ &= 10 \cos(3t - 36.9) \end{aligned}$$

P15.12-3

$$v(t) = 10 \cos 2t$$

$$\mathbf{V}(\omega) = 10\pi [\delta(\omega + 2) + \delta(\omega - 2)]$$

$$\mathbf{Y}(\omega) = \frac{1}{2 + j\omega}$$

$$\begin{aligned} \mathbf{I}(\omega) &= \mathbf{Y}(\omega)\mathbf{V}(\omega) \\ &= \frac{10\pi [\delta(\omega + 2) + \delta(\omega - 2)]}{2 + j\omega} \end{aligned}$$

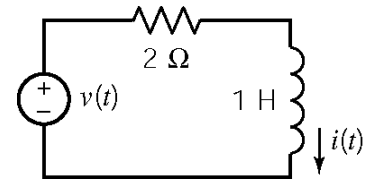

$$\begin{aligned} i(t) &= \frac{10\pi}{2\pi} \int_{-\infty}^{\infty} \left[\frac{\delta(\omega + 2) + \delta(\omega - 2)}{2 + j\omega} \right] e^{j\omega t} d\omega = 5 \left[\frac{e^{-j2t}}{2 - j2} + \frac{e^{j2t}}{2 + j2} \right] \\ &= 5 \left[e^{-j(2t-45)} + e^{j(2t-45)} \right] = 5 \cos(2t - 45) \text{ A} \end{aligned}$$

P15.12-4

$$v(t) = e^t u(-t) + u(t)$$

$$\mathcal{F}\{e^t u(-t)\} = \int_{-\infty}^{\infty} e^t u(-t) e^{-j\omega t} dt = \int_{-\infty}^0 e^t e^{-j\omega t} dt = \frac{e^{(1-j\omega)t}}{1-j\omega} \Big|_{-\infty}^0 = \frac{1}{1-j\omega}$$

$$\mathcal{F}\{u(t)\} = \pi\delta(\omega) + \frac{1}{j\omega}$$

$$\therefore V(\omega) = \frac{1}{1-j\omega} + \pi\delta(\omega) + \frac{1}{j\omega}$$

$$\left(\frac{1}{2}\right)\left(\frac{1}{j\omega}\right) = \frac{1}{2+j\omega}, \quad H(\omega) = \frac{1}{2+j\omega} = \frac{1}{3+j\omega}$$

$$V_o(\omega) = \frac{1}{3+j\omega} \left[\frac{1}{1-j\omega} + \pi\delta(\omega) + \frac{1}{j\omega} \right] = \frac{-\frac{1}{12}}{3+j\omega} + \frac{\frac{1}{4}}{1-j\omega} + \frac{\frac{1}{3}}{j\omega} + \frac{\pi\delta(\omega)}{3+j\omega}$$

$$\mathcal{F}^{-1}\left\{\frac{\pi\delta(\omega)}{3+j\omega}\right\} = \frac{1}{2\pi} \int_{-\infty}^{\infty} \frac{\pi\delta(\omega)}{3+j\omega} e^{-j\omega t} d\omega = \frac{1}{6}$$

$$\therefore v_o(t) = -\frac{1}{12} e^{-3t} u(t) + \frac{1}{4} e^t u(-t) + \frac{1}{3} \text{signum}(t) + \frac{1}{6}$$

P15.12-5

$$v_s(t) = 15e^{-5t} u(t) \quad \mathcal{V} \Rightarrow V(\omega) = \frac{15}{5+j\omega}$$

$$W_s = \int_{-\infty}^{\infty} (15e^{-5t} u(t))^2 dt = \int_0^{\infty} (15e^{-5t})^2 dt = 22.5 \quad \text{J}$$

$$H(\omega) = \frac{\frac{1}{j\omega C}}{R + \frac{1}{j\omega C}} = \frac{\frac{1}{RC}}{\frac{1}{RC} + j\omega}$$

$C=10 \mu\text{F}$. Try $R=10 \text{ k}\Omega$. Then

$$V_o(\omega) = \frac{10}{10+j\omega} \times \frac{15}{5+j\omega}$$

$$W_o = \frac{1}{\pi} \int_0^{\infty} \left(\frac{10}{10+j\omega} \times \frac{15}{5+j\omega} \right)^2 d\omega = \frac{1}{\pi} \int_0^{\infty} \left(\frac{300}{25+\omega^2} - \frac{300}{100+\omega^2} \right)^2 d\omega = 15 \quad \text{J}$$

P15.12-6

$$H(\omega) = \frac{4}{4 + j\omega}$$

$$V_s(\omega) = \mathcal{F}\{8u(t) - 8u(t-1)\} = \left(8\pi\delta(\omega) + \frac{8}{j\omega}\right) - \left(8\pi\delta(\omega) + \frac{8}{j\omega}\right)e^{-j\omega}$$

$$V_s(\omega) = \frac{8}{j\omega}(1 - e^{-j\omega}) \quad \text{since } \delta(\omega)e^{-j\omega} = \delta(\omega)$$

$$V_o(\omega) = \frac{4}{4 + j\omega} \times \frac{8}{j\omega}(1 - e^{-j\omega}) = \left(\frac{8}{j\omega} - \frac{8}{4 + j\omega}\right) - \left(\frac{8}{j\omega} - \frac{8}{4 + j\omega}\right)e^{-j\omega}$$

Next use $\frac{1}{j\omega} = \frac{1}{j\omega} + \pi\delta(\omega) - \pi\delta(\omega)$ to write

$$\begin{aligned} V_o(\omega) &= \left(8\left(\frac{1}{j\omega} + \pi\delta(\omega)\right) - \pi\delta(\omega) - \frac{8}{4 + j\omega}\right) - \left(8\left(\frac{1}{j\omega} + \pi\delta(\omega)\right) - \pi\delta(\omega) - \frac{8}{4 + j\omega}\right)e^{-j\omega} \\ &= \left(8\left(\frac{1}{j\omega} + \pi\delta(\omega)\right) - \frac{8}{4 + j\omega}\right) - \left(8\left(\frac{1}{j\omega} + \pi\delta(\omega)\right) - \frac{8}{4 + j\omega}\right)e^{-j\omega} \end{aligned}$$

$$\begin{aligned} v_o(t) &= 8u(t) - 8e^{-4t}u(t) - (8u(t-1) - 8e^{-4(t-1)}u(t-1)) \\ &= 8(1 - e^{-4t})u(t) - 8(1 - e^{-4(t-1)})u(t-1) \quad \text{V} \end{aligned}$$

PSpice Problems

SP 15-1

```
Vin 1 0 pulse (25 5 0 0 0 4 5)
R1 1 0 1

.tran 0.01 5
.four 0.2 v(1)
.probe
.end
```

FOURIER COMPONENTS OF TRANSIENT RESPONSE V(1)

DC COMPONENT = 8.960000E+00

HARMONIC NO	FREQUENCY (HZ)	FOURIER COMPONENT	NORMALIZED COMPONENT	PHASE (DEG)	NORMALIZED PHASE (DEG)
1	2.000E-01	7.419E+00	1.000E+00	1.253E+02	0.000E+00
2	4.000E-01	6.030E+00	8.127E-01	1.606E+02	3.528E+01
3	6.000E-01	4.061E+00	5.473E-01	-1.642E+02	-2.894E+02
4	8.000E-01	1.935E+00	2.609E-01	-1.289E+02	-2.542E+02
5	1.000E+00	8.000E-02	1.078E-02	-9.360E+01	-2.189E+02
6	1.200E+00	1.182E+00	1.593E-01	1.217E+02	-3.600E+00
7	1.400E+00	1.704E+00	2.297E-01	1.570E+02	3.168E+01
8	1.600E+00	1.537E+00	2.072E-01	-1.678E+02	-2.930E+02
9	1.800E+00	8.954E-01	1.207E-01	-1.325E+02	-2.578E+02

SP 15-2

```
Vin 1 0 pulse (1 -1 -0.5 1 0 0 1)
R1 1 0 1

.tran 0.1 1
.four 1 v(1)
.probe
.end
```

FOURIER COMPONENTS OF TRANSIENT RESPONSE V(1)

DC COMPONENT = 1.299437E-02

HARMONIC NO	FREQUENCY (HZ)	FOURIER COMPONENT	NORMALIZED COMPONENT	PHASE (DEG)	NORMALIZED PHASE (DEG)
1	1.000E+00	6.364E-01	1.000E+00	-1.777E+02	0.000E+00
2	2.000E+00	3.180E-01	4.996E-01	4.679E+00	1.823E+02
3	3.000E+00	2.117E-01	3.326E-01	-1.730E+02	4.682E+00
4	4.000E+00	1.585E-01	2.490E-01	9.366E+00	1.870E+02
5	5.000E+00	1.264E-01	1.987E-01	-1.683E+02	9.376E+00
6	6.000E+00	1.051E-01	1.651E-01	1.407E+01	1.917E+02
7	7.000E+00	8.972E-02	1.410E-01	-1.636E+02	1.409E+01
8	8.000E+00	7.817E-02	1.228E-01	1.880E+01	1.965E+02
9	9.000E+00	6.916E-02	1.087E-01	-1.588E+02	1.883E+01

Verification Problems

VP 15-1

$$f(t) = 2 + \cos \frac{t}{2} \Rightarrow a_0 = 2, a_1 = 1 \text{ and all other coefficients are zero.}$$

The computer printout is correct.

VP 15-2

Table 15.4-2 shows that the average value of a full wave rectified sinewave is

$$\frac{2A}{\pi} \text{ where } A \text{ is the amplitude of the sinewave. In this case } a_0 = \frac{2(400)}{\pi} = 255.$$

Unfortunately the report says, "half-wave rectified." The report is not correct.

Design Problems

DP 15-1

For sinusoidal analysis, shift horizontal axis to average, which is 6 V.

Now we have an odd function so $a_n = 0$

$$T = \pi \text{ s, } \omega_0 = 2\pi / \pi = 2 \text{ rad/s}$$

$$b_n = \frac{2 \times 2}{T} \int_0^{T/2} f(t) \sin n\omega_0 t \, dt$$

Need third harmonic :

$$b_3 = \frac{4}{T} \int_0^{\pi/2} \sin 6t \, dt = -\frac{4}{6\pi} \cos 6t \Big|_0^{\pi/2} = 0.424$$

$$v_1(t) = 0.424 \sin(6t) = 0.424 \cos(6t - 90^\circ) \text{ V} \Rightarrow \mathbf{V}_1(\omega) = 0.424 \angle -90^\circ$$

$$\mathbf{Z}_c = \frac{-j}{\omega C} = \frac{-j}{6C} \text{ for third harmonic}$$

$$\therefore \text{ transfer function is } \mathbf{H}(3\omega_0) = \frac{16}{16 - \frac{j}{6C}}$$

$$\mathbf{V}_2(\omega) = \mathbf{H}(3\omega_0) \mathbf{V}_1(\omega) = (|\mathbf{H}(3\omega_0)| \angle \mathbf{H}(3\omega_0)) (0.424 \angle -90^\circ)$$

$$\text{Choose } |\mathbf{V}_2(\omega)| = 1.36 \Rightarrow \text{ so } |\mathbf{H}(3\omega_0)| = 3.2$$

$$\text{This requires } C = \frac{1}{205} \text{ F. Then } \mathbf{H}(3\omega_0) = \frac{16}{16 - j34} = 3.2 \angle 64.9^\circ$$

$$\therefore \text{ third harmonic of } \underline{v_2(t) = 1.36 \sin(6t + 64.9^\circ)} \text{ V}$$

DP 15-2

Refer to Table 15.4-2.

$$v_s(t) = \frac{2A}{\pi} - \sum_{n=1}^N \frac{4A}{\pi} \left(\frac{1}{4n^2 - 1} \right) \cos(2n\omega_0 t)$$

In our case:

$$v_s(t) = \frac{360}{\pi} - \sum_{n=1}^N \frac{640}{\pi} \left(\frac{1}{4n^2 - 1} \right) \cos(2n377t)$$

Let $v_s(t) = v_{s0} + \sum_{n=1}^N v_{sn}(t)$ and $v_o(t) = v_{o0} + \sum_{n=1}^N v_{on}(t)$

We require ripple $\leq 0.04 \cdot$ dc output

$$\max \left(\sum_{n=1}^N v_{on}(t) \right) \leq 0.04 \cdot v_{o0} \Rightarrow |v_{o1}(t)| \leq 0.04 v_{o0}$$

but $v_{o0} = v_{s0}$ because the inductor acts like a short at dc.

Next, using the network function of the circuit gives $\mathbf{V}_{on} = \left(\frac{R}{R + j\omega_{0n}L} \right) \mathbf{V}_{sn}$.

For $n=1$:

$$\mathbf{V}_{o1} = \frac{R}{R + j\omega_0 L} \mathbf{V}_{s1} = \frac{1}{1 + j377L} \mathbf{V}_{s1}, \text{ but } |\mathbf{V}_{s1}| = \frac{640}{\pi(3)} \text{ so } \mathbf{V}_{o1} = \frac{1}{1 + j377L} \left(\frac{640}{3\pi} \right)$$

We require $|\mathbf{V}_{o1}| \leq 0.04 v_{o0}$ and $v_{o0} = v_{s0} = \frac{360}{\pi}$. Then $\frac{1}{\sqrt{1+(377)^2 L^2}} \cdot \frac{640}{3\pi} \leq 0.04 \left(\frac{360}{\pi} \right)$

Solving for L yields $L > 1.54$ mH

DP 15-3

From Table 15.5-1, the Fourier series can represent the input to the circuit as:

$$v_s(t) = \frac{1}{\pi} + \frac{j}{4} e^{j\omega_0 t} + \frac{j}{4} e^{-j\omega_0 t} + \sum_{\text{even } n=2}^{\infty} \frac{1}{\pi(1-n^2)} e^{jn\omega_0 t}$$

The transfer function of the circuit is calculated as $\mathbf{V}_{o1} = \frac{\mathbf{Z}_p}{\mathbf{Z}_L + \mathbf{Z}_p} \mathbf{V}_{s1}$ where $\mathbf{Z}_p = \frac{R}{1+j\omega RC}$

So

$$\frac{\mathbf{V}_o}{\mathbf{V}_s} = \frac{\frac{1}{LC}}{(j\omega)^2 + (j\omega)\frac{1}{RC} + \frac{1}{LC}}$$

The gain at dc, $\omega = 0$, is 1 so

$$v_{o0} = v_{s0} = \frac{1}{\pi}$$

For $n = 1$

$$|\mathbf{V}_{o1}| = \frac{1}{20} |v_{o0}| = \frac{1}{20} |v_{s0}| = \frac{1}{20\pi} \Rightarrow \frac{1/LC}{\sqrt{\omega^4 + \left(\frac{\omega}{RC}\right)^2 + \left(\frac{1}{LC}\right)^2}} = \frac{1}{20\pi}$$

We are given $\omega = 800\pi$ and $R = 75 \text{ k}\Omega$. Choosing $L = 0.1 \text{ mH}$ yields $C = 0.1 \text{ F}$

Chapter 16: Filter Circuits

Exercises

Ex. 16.3-1

$$T_n(s) = \frac{1}{s+1}$$

$$T(s) = T_n\left(\frac{s}{1250}\right) = \frac{1}{\frac{s}{1250}+1} = \frac{1250}{s+1250}$$

Problems

Section 16.3: Filters

P16.3-1

Equation 16-3.2 and Table 16-3.2 provide a third-order Butterworth low-pass filter having a cutoff frequency equal to 1 rad/s.

$$H_n(s) = \frac{1}{(s+1)(s^2+s+1)}$$

Frequency scaling so that $\omega_c = 2\pi 100 = 628$ rad/s :

$$H_L(s) = \frac{1}{\left(\frac{s}{628}+1\right)\left(\left(\frac{s}{628}\right)^2 + \frac{s}{628}+1\right)} = \frac{628^3}{(s+628)(s^2+628s+628^2)} = \frac{247673152}{(s+628)(s^2+628s+394384)}$$

P16.3-2

Equation 16-3.2 and Table 16-3.2 provide a third-order Butterworth low-pass filter having a cutoff frequency equal to 1 rad/s and a dc gain equal to 1.

$$H_n(s) = \frac{1}{(s+1)(s^2+s+1)}$$

Multiplying by 5 to change the dc gain to 5 and frequency scaling to change the cutoff frequency to $\omega_c = 100$ rad/s:

$$H_L(s) = \frac{5}{\left(\frac{s}{100}+1\right)\left(\left(\frac{s}{100}\right)^2 + \frac{s}{100}+1\right)} = \frac{5 \cdot 100^3}{(s+100)(s^2+100s+100^2)} = \frac{5000000}{(s+100)(s^2+100s+10000)}$$

P16.3-3

Use Table 16-3.2 to obtain the transfer function of a third-order Butterworth high-pass filter having a cutoff frequency equal to 1 rad/s and a dc gain equal to 5.

$$H_n(s) = \frac{5s^3}{(s+1)(s^2+s+1)}$$

Frequency scaling to change the cutoff frequency to $\omega_c = 100$ rad/s

$$H_H(s) = \frac{5\left(\frac{s}{100}\right)^3}{\left(\frac{s}{100}+1\right)\left(\left(\frac{s}{100}\right)^2 + \frac{s}{100} + 1\right)} = \frac{5 \cdot s^3}{(s+100)(s^2+100s+100^2)} = \frac{5 \cdot s^3}{(s+100)(s^2+100s+10000)}$$

P16.3-4

Use Table 16-3.2 to obtain the transfer function of a fourth-order Butterworth high-pass filter having a cutoff frequency equal to 1 rad/s and a dc gain equal to 5.

$$H_n(s) = \frac{5 \cdot s^4}{(s^2+0.765s+1)(s^2+1.848s+1)}$$

Frequency scaling can be used to adjust the cutoff frequency 500 hertz = 3142 rad/s:

$$\begin{aligned} H_H(s) &= \frac{5 \cdot \left(\frac{s}{3142}\right)^4}{\left(\left(\frac{s}{3142}\right)^2 + 0.765\left(\frac{s}{3142}\right) + 1\right)\left(\left(\frac{s}{3142}\right)^2 + 1.848\left(\frac{s}{3142}\right) + 1\right)} \\ &= \frac{5 \cdot s^4}{(s^2+2403.6s+3142^2)(s^2+5806.4s+3142^2)} \end{aligned}$$

P16.3-5

First, obtain the transfer function of a second-order Butterworth low-pass filter having a dc gain equal to 2 and a cutoff frequency equal to 2000 rad/s:

$$H_L(s) = \frac{2}{\left(\frac{s}{2000}\right)^2 + 1.414\left(\frac{s}{2000}\right) + 1} = \frac{8000000}{s^2 + 2828s + 4000000}$$

Next, obtain the transfer function of a second-order Butterworth high-pass filter having a passband gain equal to 2 and a cutoff frequency equal to 100 rad/s:

$$H_H(s) = \frac{2\left(\frac{s}{100}\right)^2}{\left(\frac{s}{100}\right)^2 + 1.414\left(\frac{s}{100}\right) + 1} = \frac{2 \cdot s^2}{s^2 + 141.4s + 10000}$$

Finally, the transfer function of the bandpass filter is

$$H_B(s) = H_L(s) \cdot H_H(s) = \frac{16000000 \cdot s^2}{(s^2 + 141.4s + 10000)(s^2 + 2828s + 4000000)}$$

P16.3-6

$$H_B(s) = 4 \left(\frac{\frac{250}{1}s}{s^2 + \frac{250}{1}s + 250^2} \right)^2 = \frac{250000s^2}{(s^2 + 250s + 62500)^2}$$

P16.3-7

First, obtain the transfer function of a second-order Butterworth high-pass filter having a dc gain equal to 2 and a cutoff frequency equal to 2000 rad/s:

$$H_L(s) = \frac{2\left(\frac{s}{2000}\right)^2}{\left(\frac{s}{2000}\right)^2 + 1.414\left(\frac{s}{2000}\right) + 1} = \frac{2s^2}{s^2 + 2828s + 4000000}$$

Next, obtain the transfer function of a second-order Butterworth low-pass filter having a passband gain equal to 2 and a cutoff frequency equal to 100 rad/s:

$$H_H(s) = \frac{2}{\left(\frac{s}{100}\right)^2 + 1.414\left(\frac{s}{100}\right) + 1} = \frac{20000}{s^2 + 141.4s + 10000}$$

Finally, the transfer function of the band-stop filter is

$$\begin{aligned} H_N(s) = H_L(s) + H_H(s) &= \frac{2s^2(s^2 + 141.4s + 10000) + 20000(s^2 + 2828s + 4000000)}{(s^2 + 141.4s + 10000)(s^2 + 2828s + 4000000)} \\ &= \frac{2s^4 + 282.8s^3 + 40000s^2 + 56560000s + 8 \cdot 10^{10}}{(s^2 + 141.4s + 10000)(s^2 + 2828s + 4000000)} \end{aligned}$$

P16.3-8

$$H_N(s) = 4 - 4 \left(\frac{\frac{250}{1}s}{s^2 + \frac{250}{1}s + 250^2} \right)^2 = \frac{4(s^2 + 62500)^2}{(s^2 + 250s + 62500)^2}$$

P16.3-9

$$H_L(s) = 4 \left(\frac{250^2}{s^2 + \frac{250}{1}s + 250^2} \right)^2 = \frac{4 \cdot 250^4}{(s^2 + 250s + 62500)^2}$$

P16.3-10

$$H_H(s) = 4 \left(\frac{s^2}{s^2 + \frac{250}{1}s + 250^2} \right)^2 = \frac{4 \cdot s^4}{(s^2 + 250s + 62500)^2}$$

Section 16.4: Second-Order Filters

P16.4-1

The transfer function is

$$T(s) = \frac{V_o(s)}{V_s(s)} = \frac{\frac{s}{RC}}{s^2 + \frac{s}{RC} + \frac{1}{LC}}$$

so

$$K = 1, \omega_0^2 = \frac{1}{LC} \text{ and } \frac{1}{RC} = \frac{\omega_0}{Q} \Rightarrow Q = RC\omega_0 = R\sqrt{\frac{C}{L}}$$

Pick $C = 1 \mu\text{F}$. Then $L = \frac{1}{C\omega_0^2} = 1 \text{H}$ and $R = Q\sqrt{\frac{L}{C}} = 1000 \Omega$

P16.4-2

The transfer function is

$$T(s) = \frac{I_o(s)}{I_s(s)} = \frac{\frac{1}{LC}}{s^2 + \frac{s}{RC} + \frac{1}{LC}}$$

so

$$K = 1, \omega_0^2 = \frac{1}{LC} \text{ and } \frac{1}{RC} = \frac{\omega_0}{Q} \Rightarrow Q = RC\omega_0 = R\sqrt{\frac{C}{L}}$$

Pick $C = 1 \mu\text{F}$ then $L = \frac{1}{C\omega_0^2} = 25 \text{H}$ and $R = Q\sqrt{\frac{L}{C}} = 3535 \Omega$

P16.4-3

The transfer function is

$$T(s) = \frac{\frac{1}{R_1 R C^2}}{s^2 + \frac{1}{RC} \left(2 + \frac{R}{R_1}\right) s + \frac{1}{R^2 C^2}}$$

Pick $C = 0.01 \mu\text{F}$, then

$$\frac{1}{RC} = \omega_0 = 2000 \Rightarrow R = 50000 = 50 \text{ k}\Omega$$

$$\frac{\omega_0}{Q} = \frac{1}{RC} \left(2 + \frac{R}{R_1}\right) \Rightarrow R_1 = \frac{R}{Q-2} = 8333 = 8.33 \text{ k}\Omega$$

P16.4-4

Pick $C = 0.02 \mu\text{F}$. Then $R_1 = 40 \text{ k}\Omega$, $R_2 = 400 \text{ k}\Omega$ and $R_3 = 3.252 \text{ k}\Omega$.

P16.4-5

Pick $C_1 = C_2 = C = 1 \mu\text{F}$. Then

$$\frac{10^6}{\sqrt{R_1 R_2}} = \omega_0$$

and

$$\frac{1}{R_1 C} = \frac{\omega_0}{Q} \Rightarrow Q = \sqrt{\frac{R_1}{R_2}} \Rightarrow R_2 = \frac{R_1}{Q^2}$$

In this case $R_2 = R_1$ and $R_1 = \frac{10^6}{1000} = 1000 = 1 \text{ k}\Omega$

P16.4-6

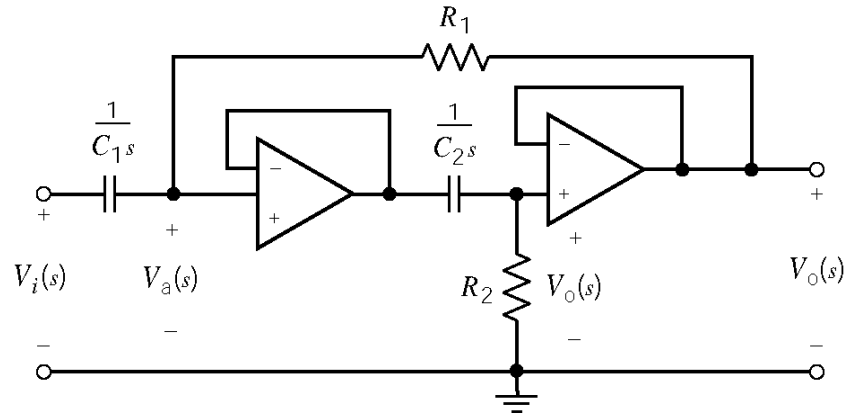

The node equations are

$$V_0(s) = \frac{R_2}{R_2 + \frac{1}{C_2 s}} V_a(s)$$

$$\frac{V_0(s) - V_a(s)}{R_1} - C_1 s (V_a(s) - V_i(s)) = 0$$

The transfer function is:

$$T(s) = \frac{V_0(s)}{V_i(s)} = \frac{s^2}{s^2 + \frac{s}{R_2 C_2} + \frac{1}{R_1 R_2 C_1 C_2}}$$

Pick $C_1 = C_2 = C = 1 \mu\text{F}$. Then $\frac{1}{C\sqrt{R_1 R_2}} = \omega_0$ and $\frac{1}{R_2 C} = \frac{\omega_0}{Q} \Rightarrow Q = \sqrt{\frac{R_2}{R_1}} \Rightarrow R_1 Q^2 = R_2$.

In this case $R_1 = R_2 = R$ and $\frac{1}{C R} = \omega_0 \Rightarrow R = 1000 \Omega$.

P16.4-7

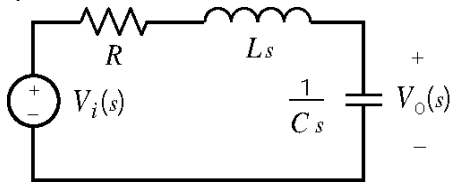

$$T(s) = \frac{V_o(s)}{V_i(s)} = \frac{\frac{1}{Cs}}{Ls + R + \frac{1}{Cs}} = \frac{\frac{1}{LC}}{s^2 + \frac{R}{L}s + \frac{1}{LC}}$$

When $R = 25 \Omega$, $L = 10^{-2} \text{ H}$ and $C = 4 \times 10^{-6} \text{ F}$, then the transfer function is

$$T(s) = \frac{25 \times 10^6}{s^2 + 2500s + 25 \times 10^6}$$

so

$$\omega_{\text{old}} = \sqrt{25 \times 10^6} = 5000$$

and

$$k_f = \frac{\omega_{\text{new}}}{\omega_{\text{old}}} = \frac{250}{5000} = 0.05$$

The scaled circuit is

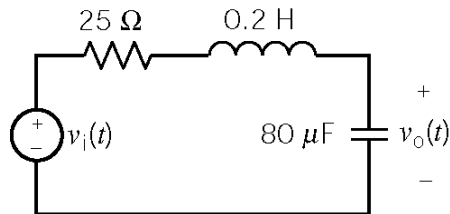

P16.4-8

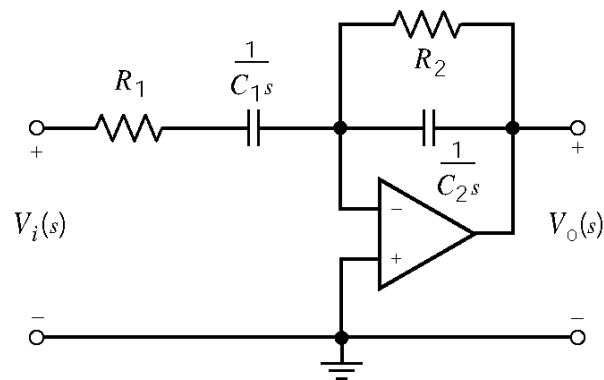

The transfer function of this circuit is

$$T(s) = \frac{V_0(s)}{V_1(s)} = -\frac{\frac{R_2}{1+R_2C_2s}}{R_1 + \frac{1}{C_1s}} = -\frac{\frac{1}{R_1C_2}s}{s^2 + \left(\frac{1}{R_1C_1} + \frac{1}{R_2C_2}\right)s + \frac{1}{R_1R_2C_1C_2}}$$

Pick $k_m = 1000$ so that the scaled capacitances will be $\frac{100 \mu\text{F}}{1000} = 0.1 \mu\text{F}$ and $\frac{500 \mu\text{F}}{1000} = 0.5 \mu\text{F}$.

Before scaling ($R_1=20 \Omega$, $C_1=100 \mu\text{F}$, $R_2=10 \Omega$ and $C_2=500 \mu\text{F}$)

$$T(s) = \frac{-100s}{s^2 + 700s + 10^5}$$

After scaling ($R_1=20000 \Omega=20 \text{ k}\Omega$, $C_1=0.1 \mu\text{F}$, $R_2=10000 \Omega=10 \text{ k}\Omega$, $C_2=0.5 \mu\text{F}$)

$$T(s) = \frac{-100s}{s^2 + 700s + 10^5}$$

P16.4-9

This is the frequency response of a bandpass filter, so

$$T(s) = \frac{K \frac{\omega_0}{Q} s}{s^2 + \frac{\omega_0}{Q} s + \omega_0^2}$$

From peak of the frequency response

$$\omega_0 = 2\pi \times 10 \times 10^6 = 62.8 \times 10^6 \text{ rad/s} \text{ and } k=10 \text{ dB} = 3.16$$

Next

$$\frac{\omega_0}{Q} = \text{BW} = (10.1 \times 10^6 - 9.9 \times 10^6) 2\pi = (0.2 \times 10^6) 2\pi = 1.26 \times 10^6 \text{ rad/s}$$

So the transfer function is

$$T(s) = \frac{3.16(1.26)10^6 s}{s^2 + (1.26)10^6 s + 62.8^2 \cdot 10^{12}} = \frac{(3.98)10^6 s}{s^2 + (1.26)10^6 s + 3.944 \cdot 10^{15}}$$

P16.4-10

(a)
$$\mathbf{H}(\omega) = \frac{\mathbf{V}_o(\omega)}{\mathbf{V}_s(\omega)} = -\frac{\mathbf{Z}_2}{\mathbf{Z}_1} \quad \text{where } \mathbf{Z}_1 = R_1 - \frac{j}{\omega C_1} \quad \text{and } \mathbf{Z}_2 = \frac{R_2 \times \frac{1}{j\omega C_2}}{R_2 + \frac{1}{j\omega C_2}}$$

$$\therefore \mathbf{H}(\omega) = -\frac{j\omega R_2 C_1}{\left(1 + \frac{j\omega}{\omega_1}\right) \left(1 + \frac{j\omega}{\omega_2}\right)} \quad \text{where } \omega_1 = \frac{1}{R_1 C_1}, \omega_2 = \frac{1}{R_2 C_2}$$

(b)
$$\omega_1 = \frac{1}{R_1 C_1}, \omega_2 = \frac{1}{R_2 C_2}$$

(c)
$$|\mathbf{H}(\omega)| = \left| -\frac{j\omega R_2 C_1}{\left(0 + \frac{j\omega}{\omega_1}\right) (1+0)} \right| = \frac{\omega R_2 C_1}{\frac{\omega}{\omega_1}} = \omega_1 R_2 C_1 = \frac{R_2}{R_1}$$

P16.4-11

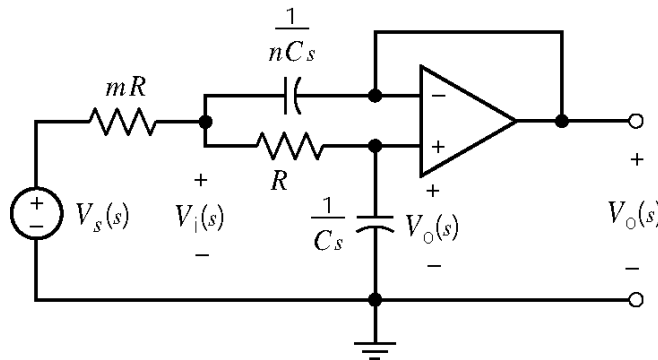

Voltage division:

$$V_0(s) = \frac{\frac{1}{C_s}}{R + \frac{1}{C_s}} V_1(s), \Rightarrow V_1(s) = (1 + sRC)V_0(s)$$

KCL:

$$\frac{V_1 - V_s}{mR} + \frac{V_1 - V_0}{R} + (V_1 - V_0)nCs = 0$$

Combining these equations gives:

$$V_0 \left[\frac{1}{mR} + sC + \frac{sC}{m} + s^2 nRC^2 \right] = \frac{V_s}{mR}$$

Therefore

$$\mathbf{H}(\omega) = \frac{V_o(\omega)}{V_s(\omega)} = \frac{1}{1 + s(m+1)RC + nmR^2C^2s^2} = \frac{1}{1 - \left(\frac{\omega}{\omega_0}\right)^2 + j\frac{\omega}{Q\omega_0}}$$

where $\omega_0 = \frac{1}{\sqrt{mn}RC}$ and $Q = \frac{\sqrt{mn}}{m+1}$

P16.4-12

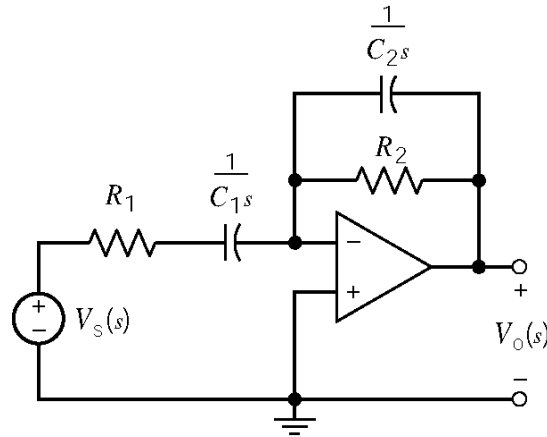

$$H(s) = \frac{V_o(s)}{V_s(s)} = -\frac{R_2 \parallel \frac{1}{C_2 s}}{R_1 + \frac{1}{C_1 s}} = \frac{R_2}{R_1 C_1 s + 1} = \frac{-\frac{1}{R_1 C_2} s}{s^2 + \left(\frac{1}{R_1 C_1} + \frac{1}{R_2 C_2}\right) s + \frac{1}{R_1 R_2 C_1 C_2}}$$

where

$$\omega_0 = \frac{1}{\sqrt{R_1 R_2 C_1 C_2}} = 70.7 \text{ k rad/sec} = 2\pi(11.25 \text{ kHz})$$

$$\text{BW} = \frac{\omega_0}{Q} = \frac{1}{R_1 C_1} + \frac{1}{R_2 C_2} = 150 \text{ k rad/s} = 2\pi(23.9 \text{ kHz})$$

P16.4-13

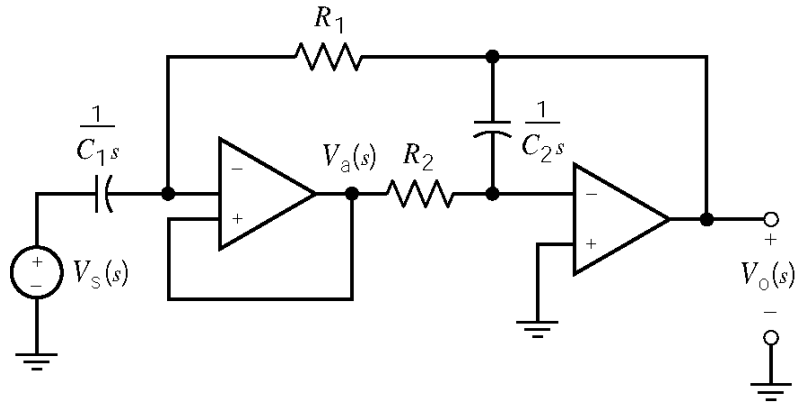

$$\left. \begin{aligned} C_1 s(V_a - V_s) + \frac{V_a - V_o}{R_1} &= 0 \\ -\frac{V_a}{R_2} - C_2 s V_o &= 0 \end{aligned} \right\} \Rightarrow H(s) = \frac{V_o(s)}{V_s(s)} = \frac{-\frac{1}{R_2 C_2} s}{s^2 + \frac{1}{R_1 C_1} s + \frac{1}{R_1 R_2 C_1 C_2}}$$

Comparing this transfer function to the standard form of the transfer function of a second order bandpass filter gives:

$$\omega_0 = \frac{1}{\sqrt{R_1 R_2 C_1 C_2}} = 10^4 \text{ rad/sec}$$

$$\text{BW} = \frac{1}{R_1 C_1} = 10^3 \text{ rad/sec}$$

$$Q = \frac{\omega_0}{\text{BW}} = 10$$

P16.4-14

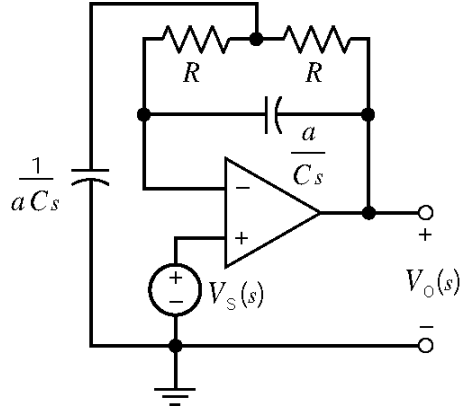

Node equations:

$$a C s V_c(s) + \frac{V_c(s) - V_s(s)}{R} + \frac{V_c(s) - V_o(s)}{R} = 0$$

$$\frac{C}{a} s (V_s(s) - V_o(s)) + \frac{V_s(s) - V_c(s)}{R} = 0$$

Solving these equations yields the transfer function:

$$H(s) = \frac{V_o(s)}{V_s(s)} = \frac{s^2 + \left(\frac{2}{a} + a\right) \frac{1}{RC} s + \frac{1}{(RC)^2}}{s^2 + \left(\frac{2}{a}\right) \frac{1}{RC} s + \frac{1}{(RC)^2}}$$

We require $10^5 = \frac{1}{RC}$. Pick $C = 0.01 \mu\text{F}$ then $R = 1000 \Omega$. Next at $s = j\omega_0$

$$|\mathbf{H}(\omega_0)| = \frac{\frac{2}{a} + a}{\frac{2}{a}} = 1 + \frac{a^2}{2}$$

The specifications require

$$201 = |\mathbf{H}(\omega_0)| = 1 + \frac{a^2}{2} \Rightarrow a = 20$$

P16.4-15

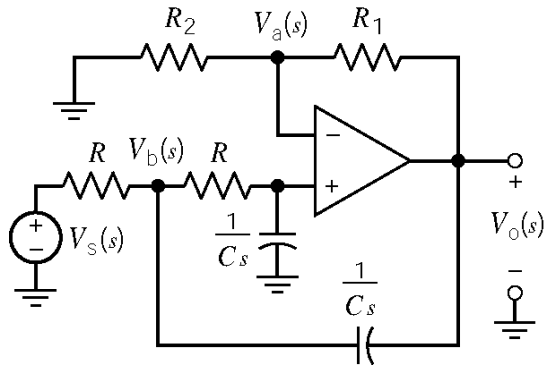

Node equations:

$$\frac{V_a}{R_2} + \frac{V_a - V_0}{R_1} = 0$$

$$C s V_a + \frac{V_a - V_b}{R} = 0$$

$$C s (V_b - V_0) + \frac{V_b - V_s}{R} = 0$$

Solving the node equation yields:

$$\frac{V_0(s)}{V_s(s)} = \frac{\left(1 + \frac{R_1}{R_2}\right) \frac{1}{R^2 C^2}}{s^2 + \left(2 - \frac{R_1}{R_2}\right) \frac{1}{RC} s + \frac{1}{R^2 C^2}}$$

$$\omega_0 = \frac{1}{RC} = \frac{1}{(1.2 \times 10^3)(20 \times 10^{-9})} = 41.67 \text{ krad/sec}$$

Section 16.5: High-Order Filters

P16.5-1

This filter is designed as a cascade connection of a Sallen-key low-pass filter designed as described in Table 16.4-2 and a first-order low-pass filter designed as described in Table 16.5-2.

Sallen-Key Low-Pass Filter:

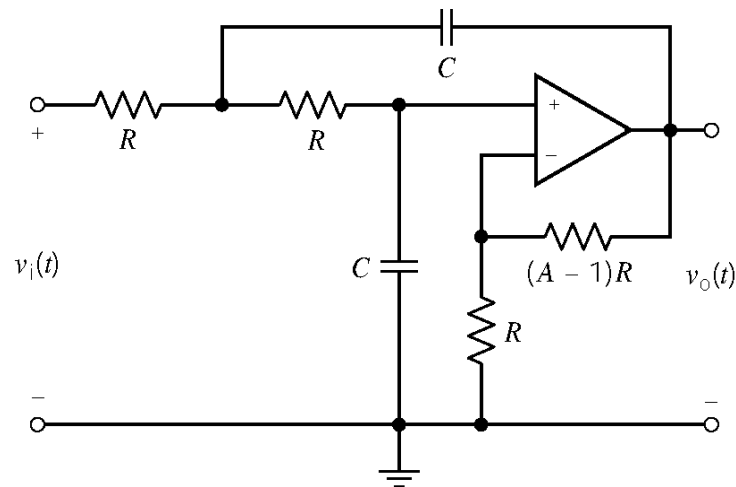

MathCad Spreadsheet (p16_5_1_sklp.mcd)

The transfer function is of the form $T(s) = \frac{c}{s^2 + bs + a}$.

Enter the transfer function coefficients: $a := 628^2$ $b := 628$

Determine the Filter Specifications: $\omega_0 := \sqrt{a}$ $Q := \frac{\omega_0}{b}$ $\omega_0 = 628$ $Q = 0.707$

Pick a convenient value for the capacitance: $C := 0.1 \cdot 10^{-6}$

Calculate resistance values: $R := \frac{1}{C \cdot \omega_0}$ $A := 3 - \frac{1}{Q}$ $R = 1.592 \times 10^4$ $R \cdot (A - 1) = 9.331 \times 10^3$

Calculate the dc gain. $A = 1.586$

First-Order Low-Pass Filter:

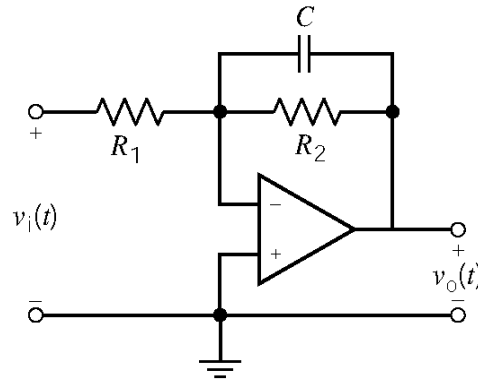

MathCad Spreadsheet (p16_5_1_1stlp.mcd)

The transfer function is of the form $T(s) = \frac{-k}{s + p}$.

Enter the transfer function coefficients: $p := 628$ $k := 0.5p$

Pick a convenient value for the capacitance: $C := 0.1 \cdot 10^{-6}$

Calculate resistance values: $R_2 := \frac{1}{C \cdot p}$ $R_1 := \frac{1}{C \cdot k}$ $R_1 = 3.185 \times 10^4$ $R_2 = 1.592 \times 10^4$

P16.5-2

This filter is designed as a cascade connection of a Sallen-key high-pass filter, designed as described in Table 16.4-2, and a first-order high-pass filter, designed as described in Table 16.5-2.

The passband gain of the Sallen key stage is 2 and the passband gain of the first-order stage is 2.5 So the overall passband gain is $2 \times 2.5 = 5$

Sallen-Key High-Pass Filter:

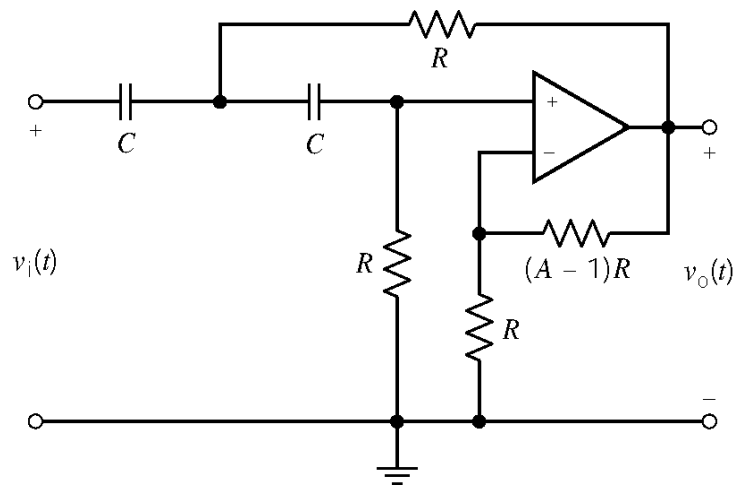

MathCad Spreadsheet (p16_5_2_skhp.mcd)

The transfer function is of the form $T(s) = \frac{A s^2}{s^2 + bs + a}$.

Enter the transfer function coefficients: $a := 10000$ $b := 100$

Determine the Filter Specifications: $\omega_0 := \sqrt{a}$ $Q := \frac{\omega_0}{b}$ $\omega_0 = 100$ $Q = 1$

Pick a convenient value for the capacitance: $C := 0.1 \cdot 10^{-6}$

Calculate resistance values: $R := \frac{1}{C \cdot \omega_0}$ $A := 3 - \frac{1}{Q}$ $R = 1 \times 10^5$ $R \cdot (A - 1) = 1 \times 10^5$

Calculate the passband gain. $A = 2$

First-Order High-Pass Filter:

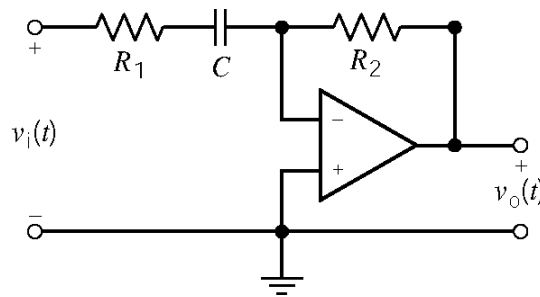

MathCad Spreadsheet (p16_5_2_1sthp.mcd)

The transfer function is of the form $T(s) = \frac{-ks}{s + p}$.

Enter the transfer function coefficients: $p := 100$ $k := 2.5$

Pick a convenient value for the capacitance: $C := 0.1 \cdot 10^{-6}$

Calculate resistance values: $R1 := \frac{1}{C \cdot p}$ $R2 := k \cdot R1$ $R1 = 1 \times 10^5$ $R2 = 2.5 \times 10^5$

P16.5-3

This filter is designed as a cascade connection of a Sallen-key low-pass filter, a Sallen-key high-pass filter and an inverting amplifier.

Sallen-Key Low-Pass Filter:

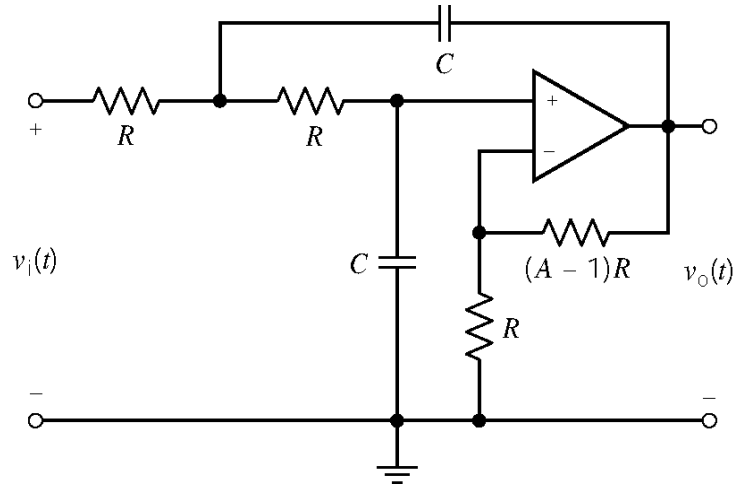

MathCad Spreadsheet (p16_5_3_skfp.mcd)

The transfer function is of the form $T(s) = \frac{c}{s^2 + bs + a}$.

Enter the transfer function coefficients: $a := 4000000$ $b := 2828$

Determine the Filter Specifications: $\omega_0 := \sqrt{a}$ $Q := \frac{\omega_0}{b}$ $\omega_0 = 2 \times 10^3$ $Q = 0.707$

Pick a convenient value for the capacitance: $C := 0.1 \cdot 10^{-6}$

Calculate resistance values: $R := \frac{1}{C \cdot \omega_0}$ $A := 3 - \frac{1}{Q}$ $R = 5 \times 10^3$ $R \cdot (A - 1) = 2.93 \times 10^3$

Calculate the dc gain. $A = 1.586$

Sallen-Key High-Pass Filter:

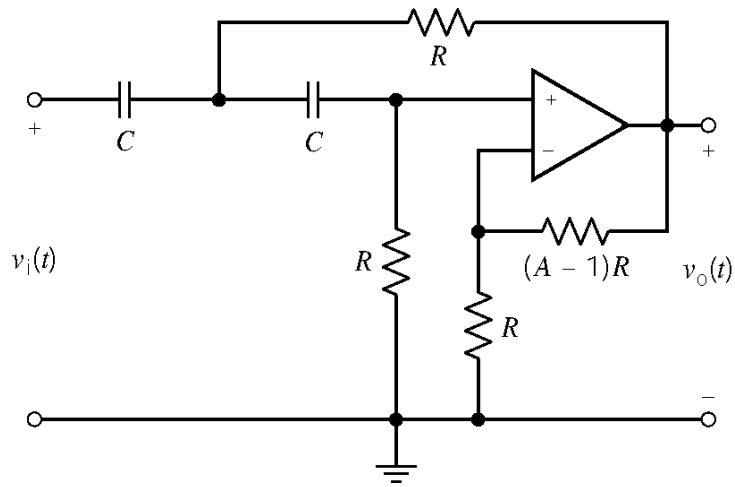

MathCad Spreadsheet (p16_5_3_skhp.mcd)

The transfer function is of the form $T(s) = \frac{c s^2}{s^2 + bs + a}$.

Enter the transfer function coefficients: $a := 10000$ $b := 141.4$

Determine the Filter Specifications: $\omega_0 := \sqrt{a}$ $Q := \frac{\omega_0}{b}$ $\omega_0 = 100$ $Q = 0.707$

Pick a convenient value for the capacitance: $C := 0.1 \cdot 10^{-6}$

Calculate resistance values: $R := \frac{1}{C \cdot \omega_0}$ $A := 3 - \frac{1}{Q}$ $R = 1 \times 10^5$ $R \cdot (A - 1) = 5.86 \times 10^4$

Calculate the passband gain. $A = 1.586$

Amplifier: The required passband gain is $\frac{1.6 \times 10^6}{141.4 \times 2828} = 4.00$. An amplifier with a gain equal to $\frac{4.0}{2.515} = 1.59$ is needed to achieve the specified gain.

P16.5-4

This filter is designed as the cascade connection of two identical Sallen-key bandpass filters:

Sallen-Key BandPass Filter:

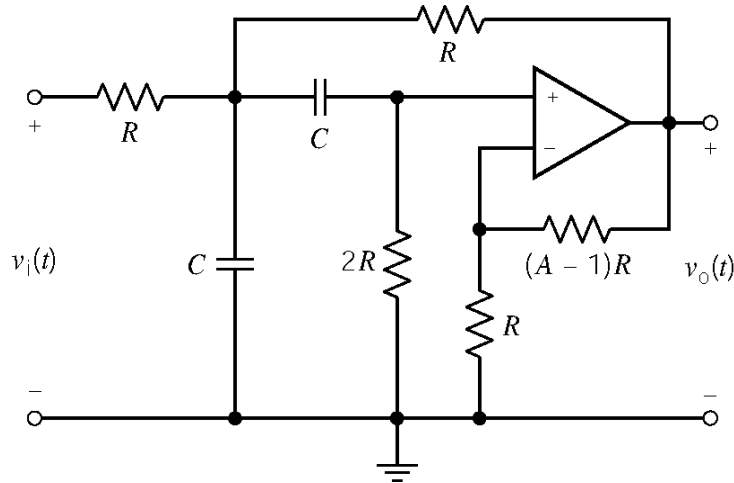

MathCad Spreadsheet (p16_5_4_skbp.mcd)

The transfer function is of the form $T(s) = \frac{cs}{s^2 + bs + a}$.

Enter the transfer function coefficients: $a := 62500$ $b := 250$

Determine the Filter Specifications: $\omega_0 := \sqrt{a}$ $Q := \frac{\omega_0}{b}$ $\omega_0 = 250$ $Q = 1$

Pick a convenient value for the capacitance: $C := 0.1 \cdot 10^{-6}$

Calculate resistance values: $R := \frac{1}{C \cdot \omega_0}$ $A := 3 - \frac{1}{Q}$

$R = 4 \times 10^4$ $2 \cdot R = 8 \times 10^4$ $R \cdot (A - 1) = 4 \times 10^4$

Calculate the pass-band gain. $A \cdot Q = 2$

P16.5-5

This filter is designed using this structure:

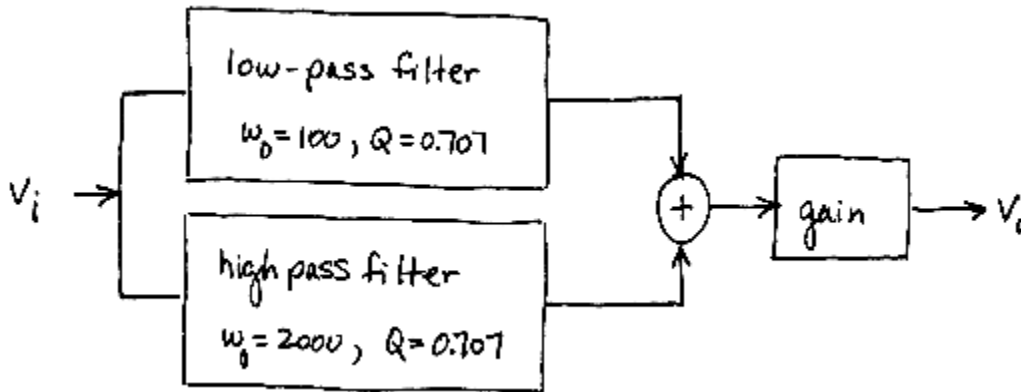

Sallen-Key Low-Pass Filter:

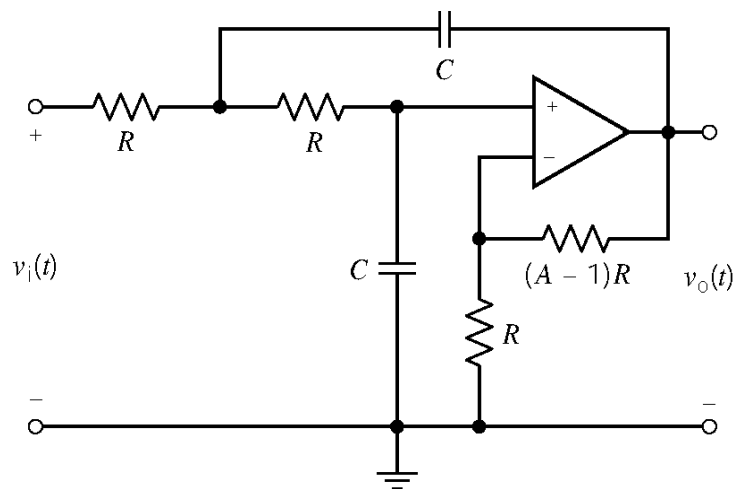

MathCad Spreadsheet (p16_5_5_skfp.mcd)

The transfer function is of the form $T(s) = \frac{c}{s^2 + bs + a}$.

Enter the transfer function coefficients: $a := 10000$ $b := 141.4$

Determine the Filter Specifications: $\omega_0 := \sqrt{a}$ $Q := \frac{\omega_0}{b}$ $\omega_0 = 100$ $Q = 0.707$

Pick a convenient value for the capacitance: $C := 0.1 \cdot 10^{-6}$

Calculate resistance values: $R := \frac{1}{C \cdot \omega_0}$ $A := 3 - \frac{1}{Q}$ $R = 1 \times 10^5$ $R \cdot (A - 1) = 5.86 \times 10^4$

Calculate the dc gain. $A = 1.586$

Sallen-Key High-Pass Filter:

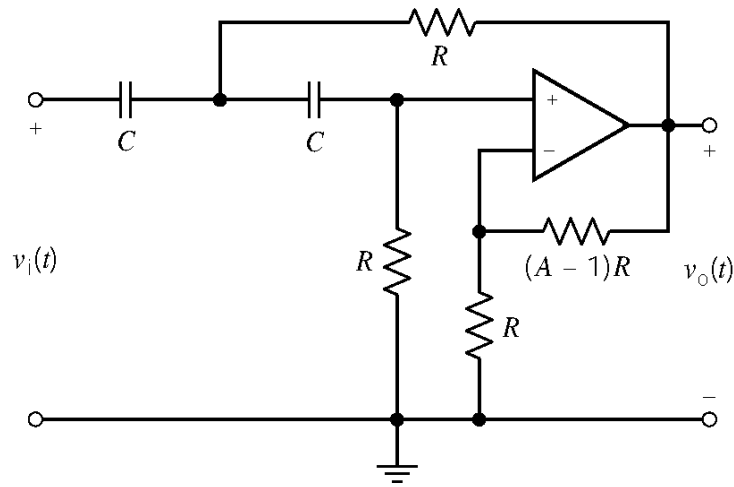

MathCad Spreadsheet (p16_5_5_skhp.mcd)

The transfer function is of the form $T(s) = \frac{c s^2}{s^2 + bs + a}$.

Enter the transfer function coefficients: $a := 4000000$ $b := 2828$

Determine the Filter Specifications: $\omega_0 := \sqrt{a}$ $Q := \frac{\omega_0}{b}$ $\omega_0 = 2 \times 10^3$ $Q = 0.707$

Pick a convenient value for the capacitance: $C := 0.1 \cdot 10^{-6}$

Calculate resistance values: $R := \frac{1}{C \cdot \omega_0}$ $A := 3 - \frac{1}{Q}$ $R = 5 \times 10^3$ $R \cdot (A - 1) = 2.93 \times 10^3$

Calculate the passband gain. $A = 1.586$

Amplifier: The required gain is 2, but both Sallen-Key filters have passband gains equal to 1.586.

The amplifier has a gain of $\frac{2}{1.586} = 1.26$ to make the passband gain of the entire filter equal to 2.

P16.5-6

This filter is designed as the cascade connection of two identical Sallen-key notch filters.

Sallen-Key Notch Filter:

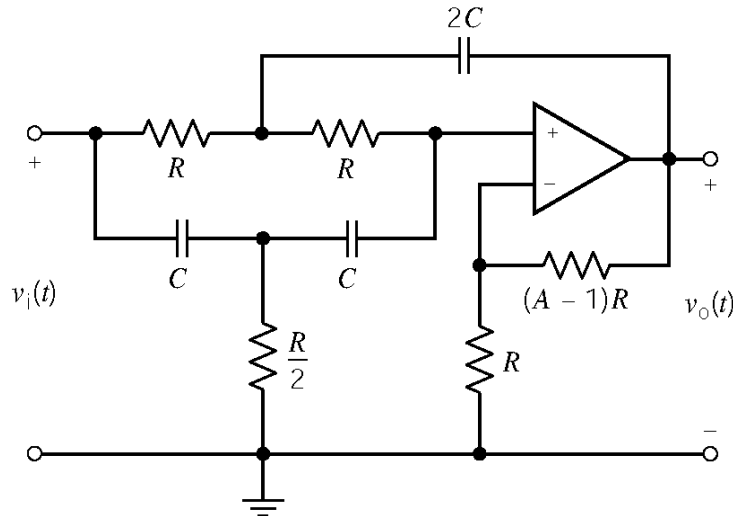

MathCad Spreadsheet (p16_5_6_skn.mcd)

The transfer function is of the form $T(s) = \frac{c(s^2 + a)}{s^2 + bs + a}$.

Enter the transfer function coefficients: $a := 62500$ $b := 250$

Determine the Filter Specifications: $\omega_0 := \sqrt{a}$ $Q := \frac{\omega_0}{b}$ $\omega_0 = 250$ $Q = 1$

Pick a convenient value for the capacitance: $C := 0.1 \cdot 10^{-6}$ $2 \cdot C = 2 \times 10^{-7}$

Calculate resistance values: $R := \frac{1}{C \cdot \omega_0}$ $A := 2 - \frac{1}{2 \cdot Q}$

$R = 4 \times 10^4$ $\frac{R}{2} = 2 \times 10^4$ $R \cdot (A - 1) = 2 \times 10^4$

Calculate the pass-band gain. $A = 1.5$

Amplifier: The required passband gain is 4. An amplifier having gain equal to $\frac{4}{(1.5)(1.5)} = 1.78$ is needed to achieve the required gain.

P16.5-7

(a) Voltage division gives:
$$H_a(s) = \frac{V_1(s)}{V_s(s)} = \frac{R_1}{R_1 + \frac{1}{Cs}} = \frac{R_1 Cs}{1 + R_1 Cs}$$

(b) Voltage division gives:
$$H_b(s) = \frac{V_2(s)}{V_1(s)} = \frac{Ls}{R_2 + Ls}$$

(c) Voltage division gives:
$$H_c(s) = \frac{V_2(s)}{V_s(s)} = \frac{R_1 \parallel (R_2 + Ls)}{\frac{1}{Cs} + R_1 \parallel (R_2 + Ls)} \times \frac{Ls}{R_2 + Ls}$$

Doing some algebra:

$$\begin{aligned} H_c(s) &= \frac{V_2(s)}{V_s(s)} = \frac{\frac{R_1 \times (R_2 + Ls)}{R_1 + (R_2 + Ls)}}{\frac{1}{Cs} + \frac{R_1 \times (R_2 + Ls)}{R_1 + (R_2 + Ls)}} \times \frac{Ls}{R_2 + Ls} \\ &= \frac{R_1 R_2 Cs + R_1 LCs^2}{R_1 R_2 Cs + R_1 LCs^2 + R_1 + R_2 + Ls} \times \frac{Ls}{R_2 + Ls} \\ &= \frac{R_1 Cs(R_2 + Ls)}{R_1 LCs^2 + (R_1 R_2 C + L)s + R_1 + R_2} \times \frac{Ls}{R_2 + Ls} \\ &= \frac{R_1 LCs^2}{R_1 LCs^2 + (R_1 R_2 C + L)s + R_1 + R_2} \end{aligned}$$

(d) $H_c(s) \neq H_a(s) \times H_b(s)$ because the R_2, Ls voltage divider loads the $\frac{1}{Cs}$, R_1 voltage divider.

P16.5-8

$$H(s) = \frac{100}{\left(1 + \frac{s}{200\pi}\right)\left(1 + \frac{s}{20,000\pi}\right)} \times \frac{20}{\left(1 + \frac{s}{20\pi}\right)\left(1 + \frac{s}{2000\pi}\right)}$$

$$= \frac{2000}{\left(1 + \frac{s}{20\pi}\right)\left(1 + \frac{s}{200\pi}\right)\left(1 + \frac{s}{2000\pi}\right)\left(1 + \frac{s}{20,000\pi}\right)}$$

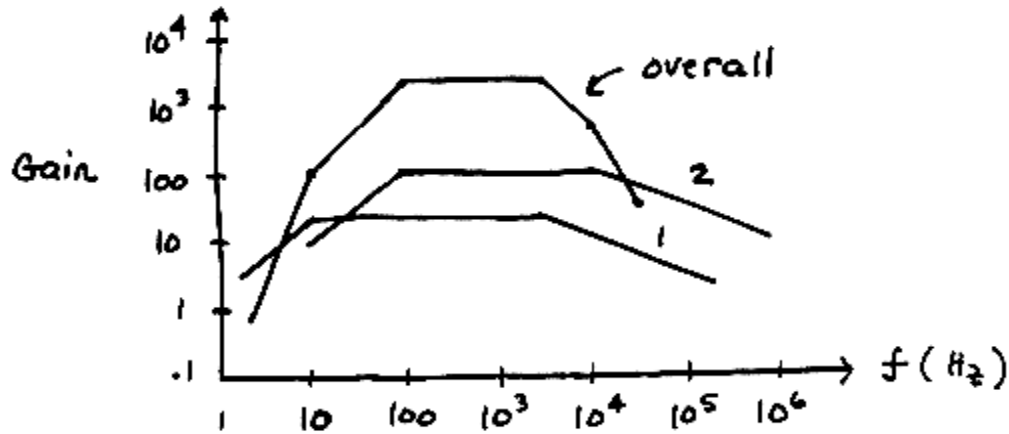

P16.5-9

(a) The transfer function of each stage is

$$H_i(s) = \frac{R_2 \parallel \frac{1}{Cs}}{R_1} = \frac{R_2 \times \frac{1}{Cs}}{R_2 + \frac{1}{Cs}} = \frac{R_2}{1 + R_2 Cs} = \frac{\frac{R_2}{R_1}}{1 + R_2 Cs}$$

The specification that the dc gain is 0 db = 1 requires $R_2 = R_1$.

The specification of a break frequency of 1000 rad/s requires $\frac{1}{R_2 C} = 1000$.

Pick $C = 0.1 \mu\text{F}$. Then $R_2 = 10 \text{ k}\Omega$ so $R_1 = 10 \text{ k}\Omega$.

(b)

$$\mathbf{H}(\omega) = \frac{-1}{1 + j\frac{\omega}{1000}} \times \frac{-1}{1 + j\frac{\omega}{1000}} \Rightarrow |\mathbf{H}(10,000)| = \left(\frac{1}{\sqrt{1+10^2}}\right)^2 = \frac{1}{101} = -40.1 \text{ dB}$$

PSpice Problems

SP 16-1

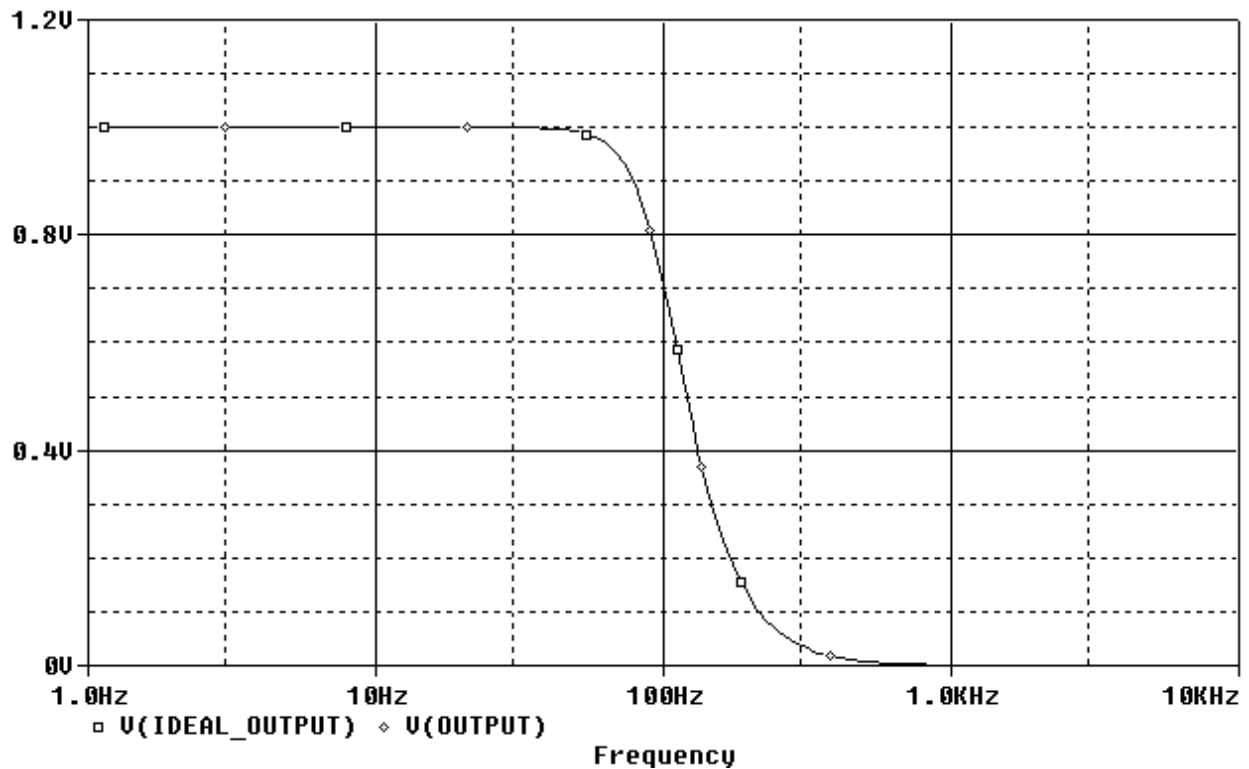
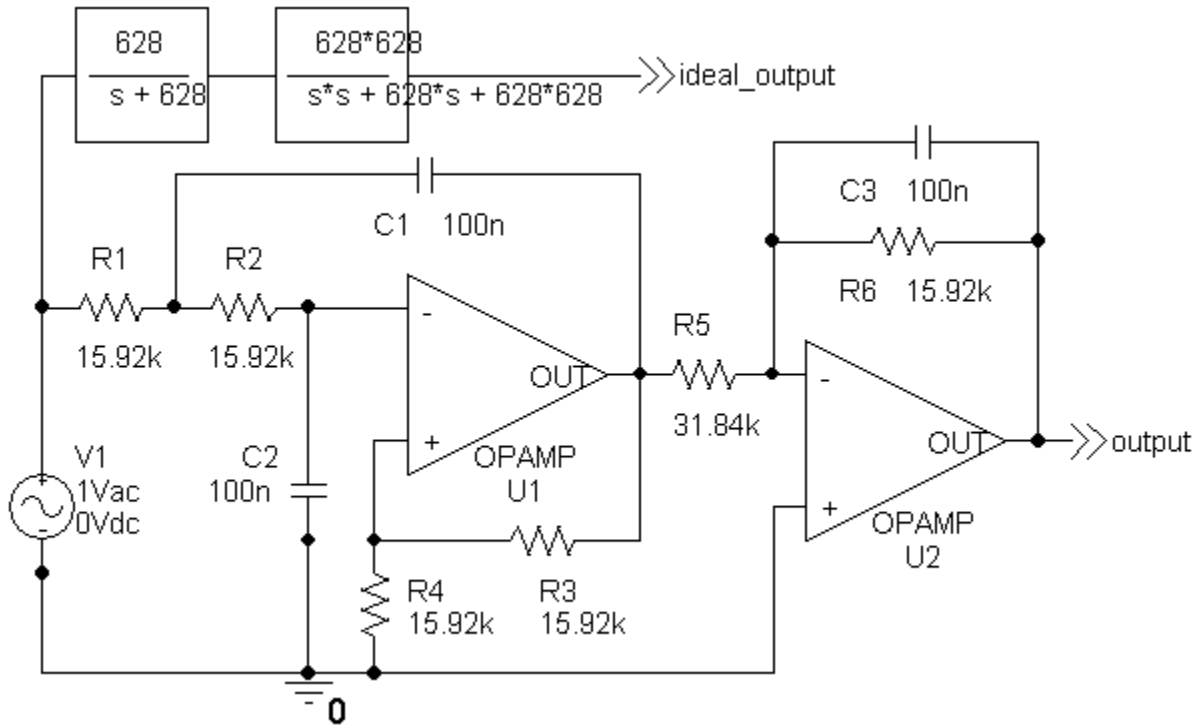

SP 16-2

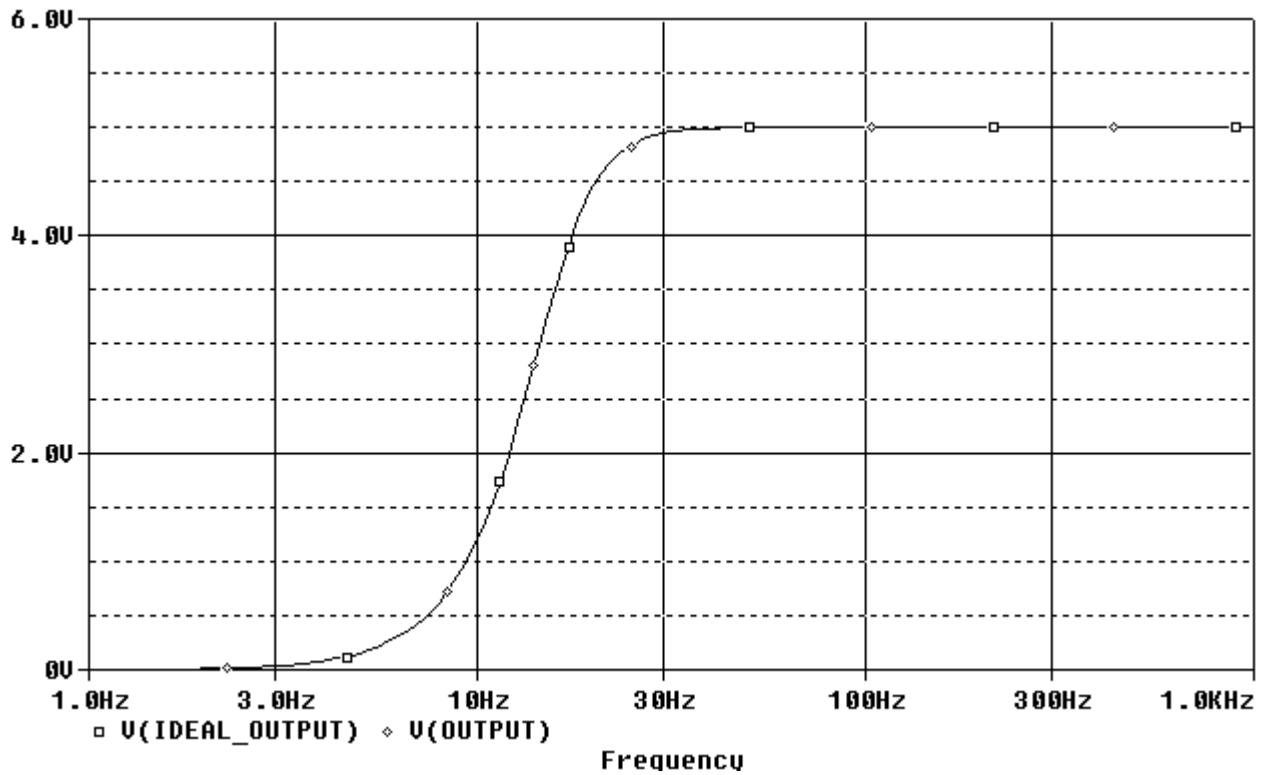
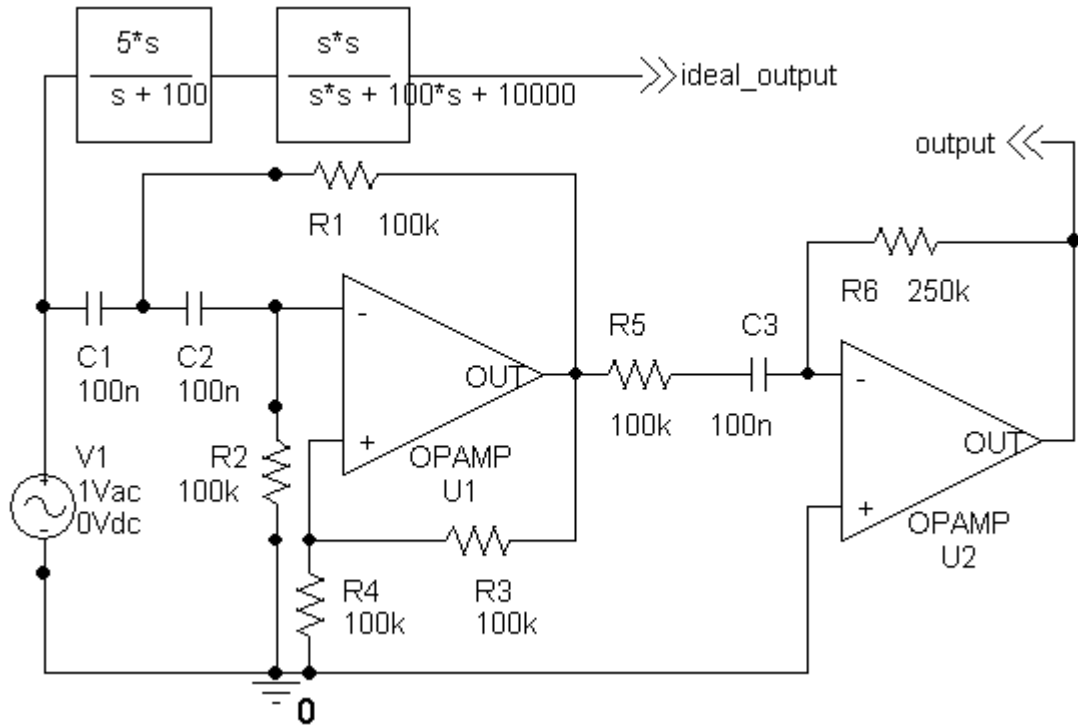

SP 16-3

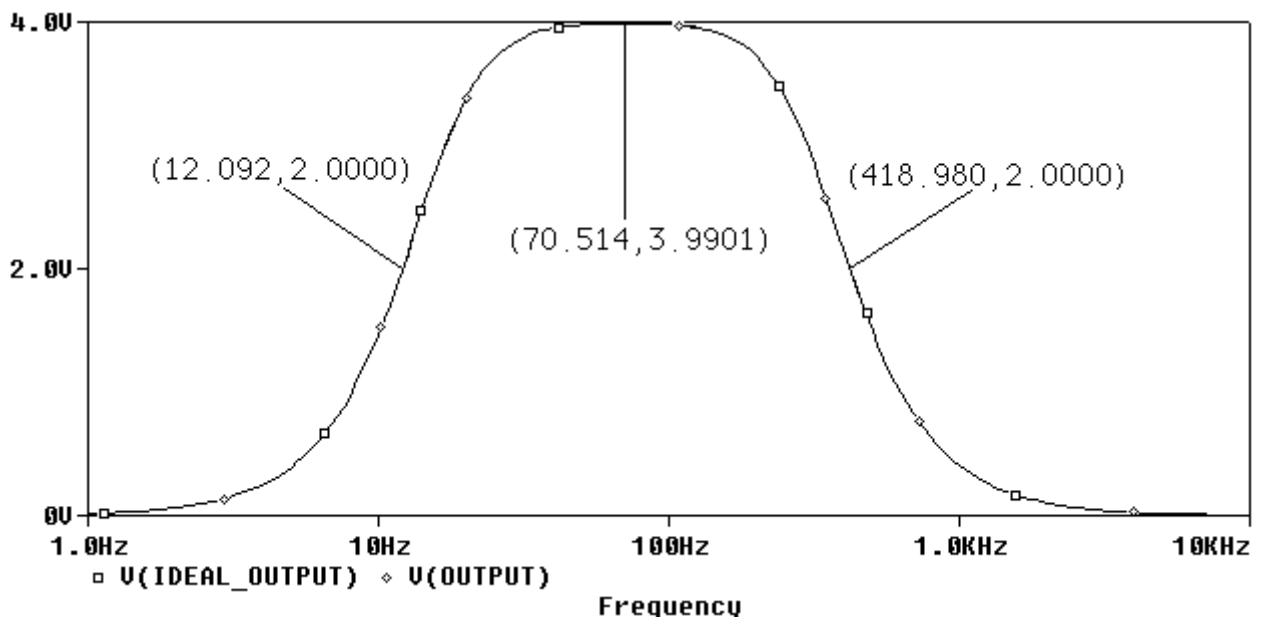
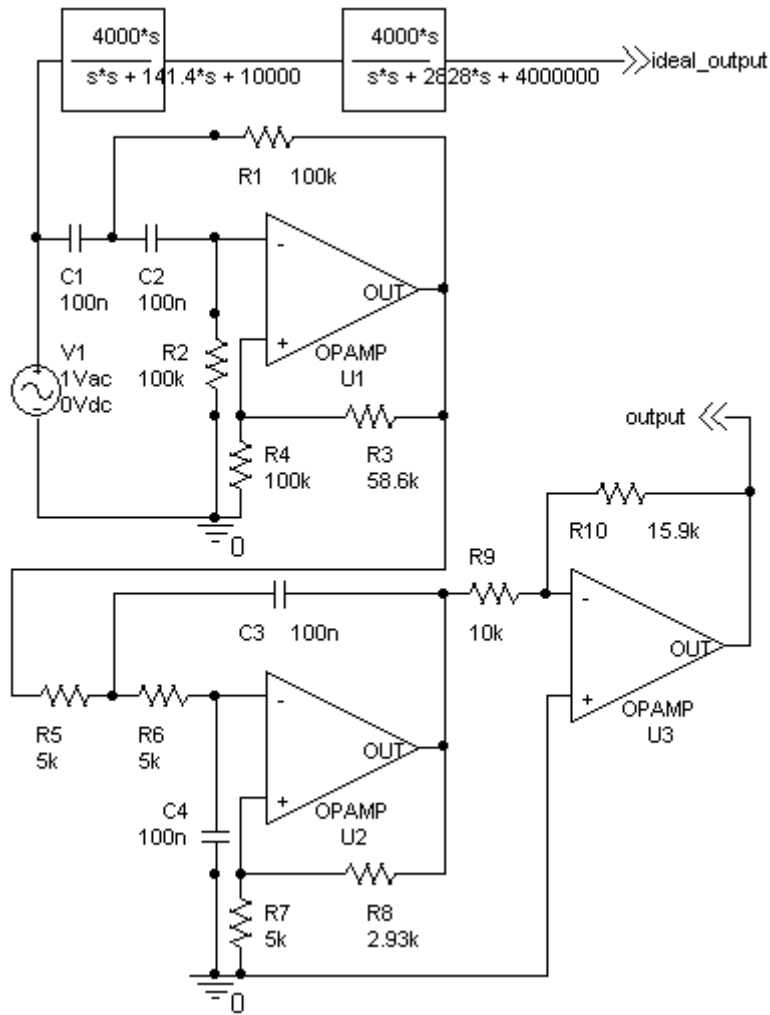

SP 16-4

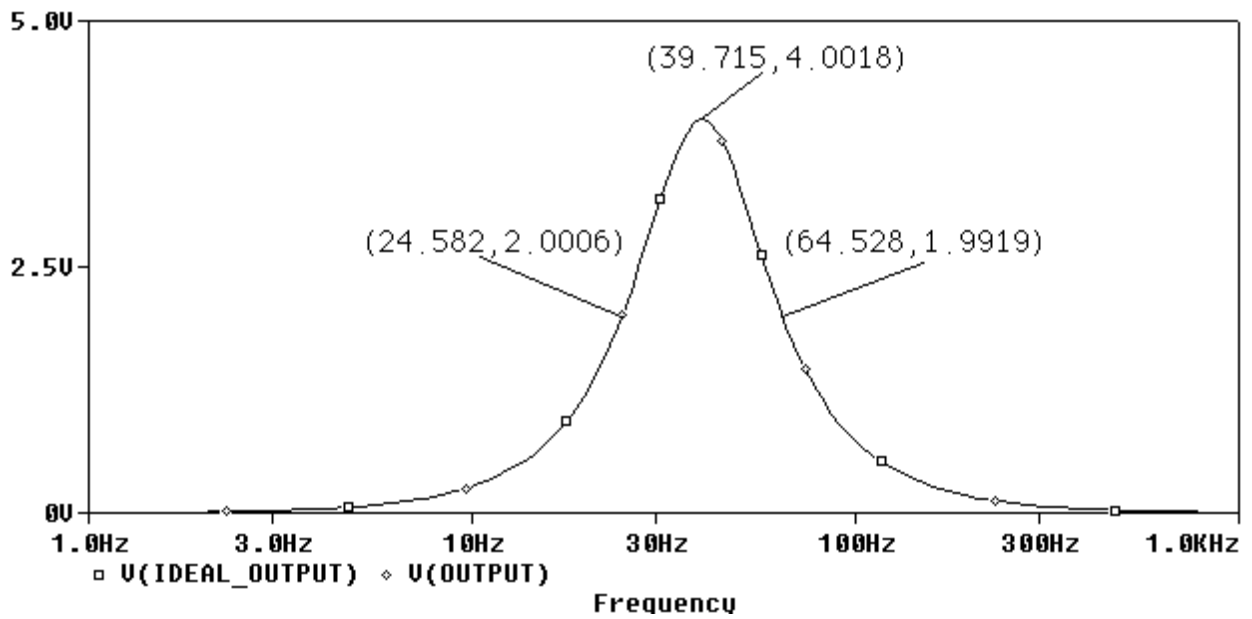
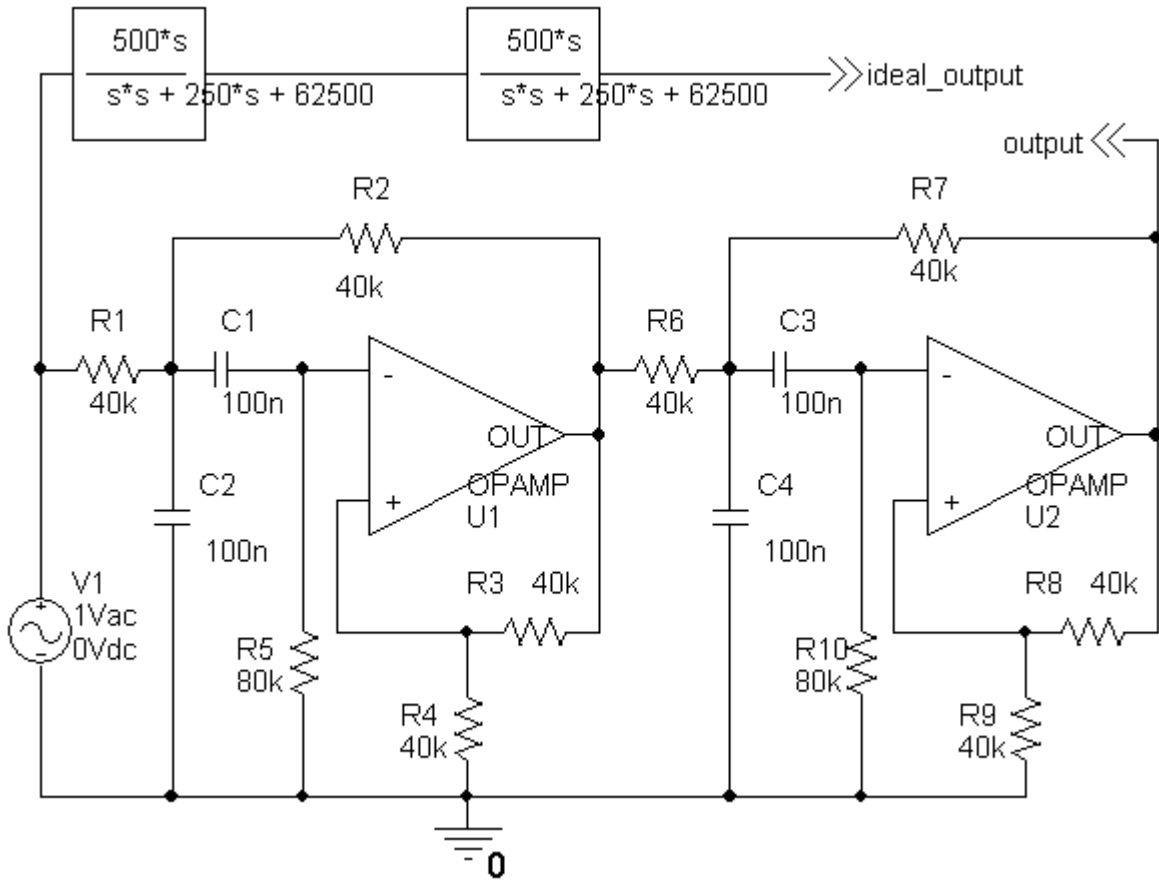

SP 16-5

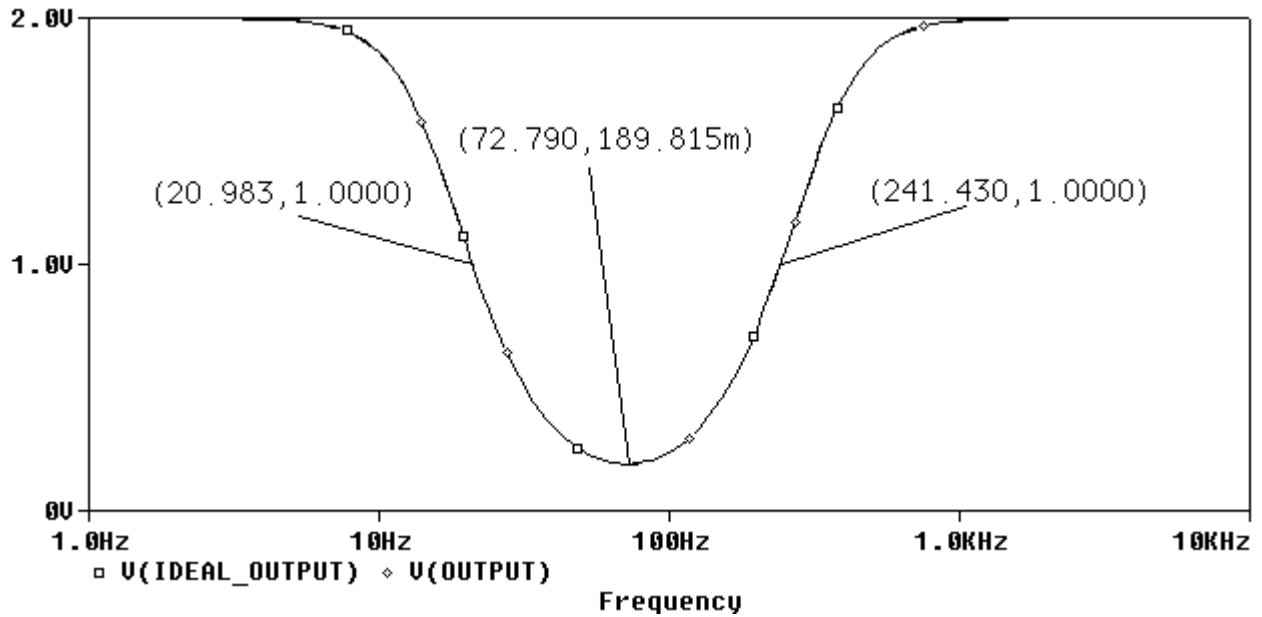
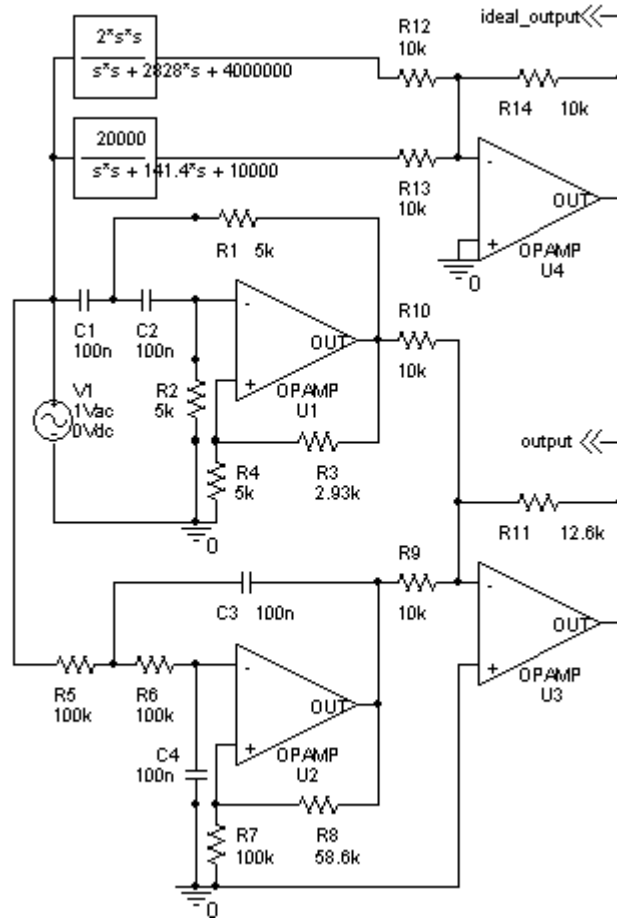

SP 16-6

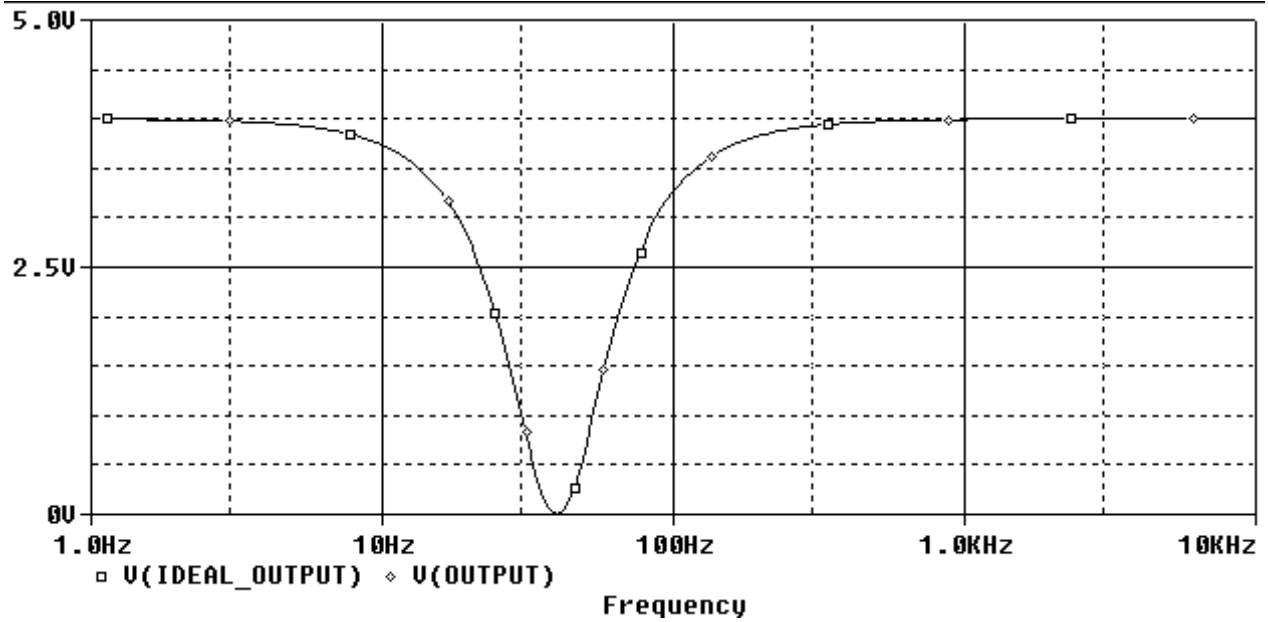
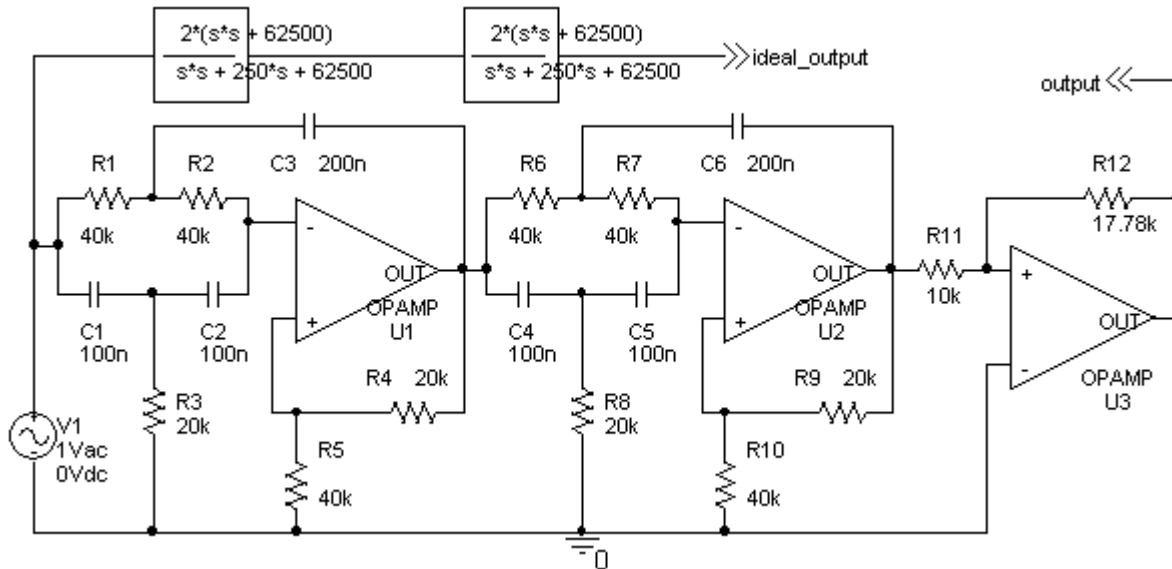

SP 16-7

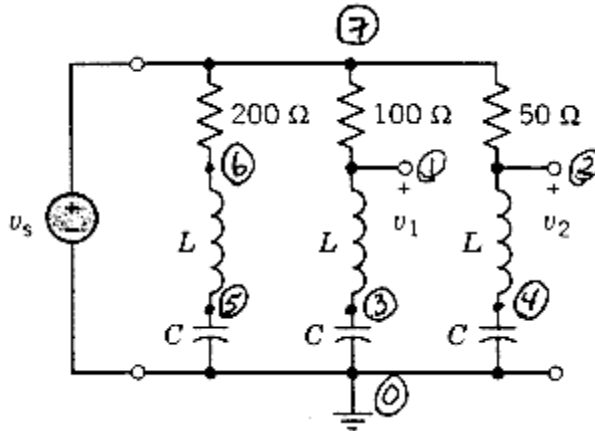

```

Vs 7 0 ac 1
R1 7 6 200
R2 7 1 100
R3 7 2 50
L1 6 5 10m
L2 1 3 10m
L3 2 4 10m
C1 5 0 1u
C2 3 0 1u
C3 4 0 1u
    
```

```

.ac dec 100 100 10k
.probe
.end
    
```

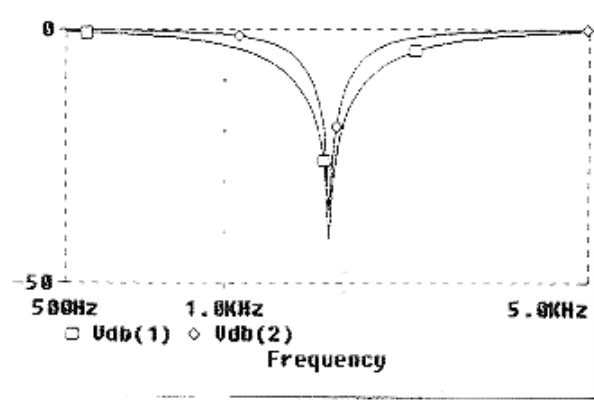

SP 16-8

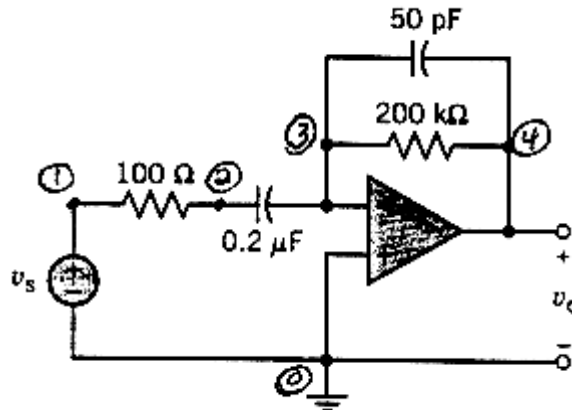

```

Vs 1 0 ac 1
R1 1 2 100
    
```

```

C1 2 3 0.2u
R2 3 4 200k
C2 3 4 50p

Xoa5 3 0 4 FGOA

.subckt FGOA 1 2 4
*nodes listed in order - + o
Ri 1 2 500k
E 3 0 1 2 100k
Ro 4 3 1k
.ends FGOA

.ac dec 100 1k 100k
.probe
.end

```

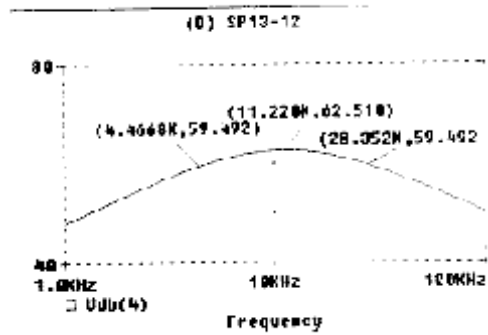

SP 16-9

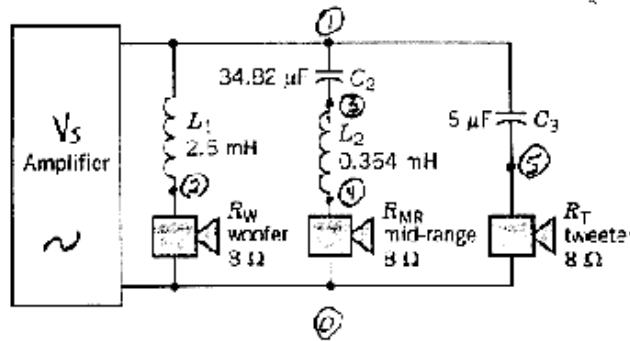

```

Vs 1 0 ac 1
L1 1 2 2.5m
Rw 2 0 8
C2 1 3 34.82u
L2 3 4 0.364m
Rmr 4 0 8
C3 1 5 5u
Rt 5 0 8

.ac dec 100 10 100k
.probe
.end

```

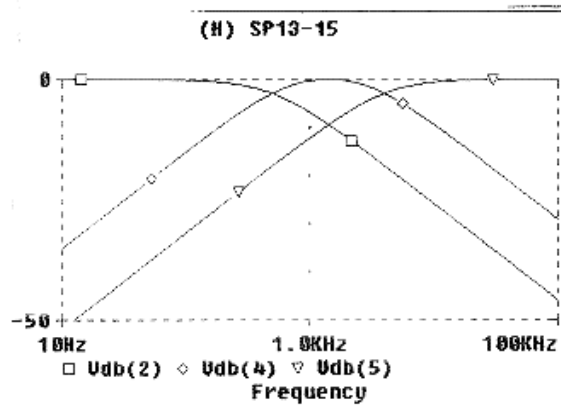

$$Bw = 4.07k - 493 \text{ Hz} \approx 3600 \text{ Hz}$$

Verification Problems

VP 16.1

$$\omega_0 = \sqrt{10000} = 100 \text{ rad/s} \text{ and } \frac{\omega_0}{Q} = 25 \Rightarrow Q = \frac{100}{25} = 4 \neq 5$$

This filter does not satisfy the specifications.

VP 16.2

$$\omega_0 = \sqrt{10000} = 100 \text{ rad/s}, \frac{\omega_0}{Q} = 25 \Rightarrow Q = \frac{100}{25} = 4 \text{ and } k = \frac{75}{25} = 3$$

This filter does satisfy the specifications.

VP 16.3

$$\omega_0 = \sqrt{400} = 20 \text{ rad/s}, \frac{\omega_0}{Q} = 25 \Rightarrow Q = \frac{20}{25} = 0.8 \text{ and } k = \frac{600}{400} = 1.5$$

This filter does satisfy the specifications.

VP 16.4

$$\omega_0 = \sqrt{625} = 25 \text{ rad/s}, \frac{\omega_0}{Q} = 62.5 \Rightarrow Q = \frac{25}{62.5} = 0.4 \text{ and } k = \frac{750}{625} = 1.2$$

This filter does satisfy the specifications.

VP 16.5

$$\omega_0 = \sqrt{144} = 12 \text{ rad/s} \text{ and } \frac{\omega_0}{Q} = 30 \Rightarrow Q = \frac{12}{30} = 0.4$$

This filter does not satisfy the specifications.

Design Problems

DP 16.1

$$\frac{V_0(s)}{V_1(s)} = \frac{-\frac{s}{RC}}{s + \frac{2}{R_3 C} s + \frac{2}{RR_3 C^2}}$$

$$2\pi(100 \cdot 10^3) = \omega_0 = \sqrt{\frac{2}{RR_3 C^2}} \quad \text{and} \quad 2\pi(10 \cdot 10^3) = \text{BW} = \frac{\omega_0}{Q} = \frac{2}{R_3 C}$$

$$C = 100 \text{ pF is specified so } R_3 = \frac{2}{(100 \times 10^{-12})(2\pi \times 10 \times 10^3)} = 318 \text{ k}\Omega \quad \text{and} \quad R = \frac{2}{R_3 C^2 \omega_0^2} = 1.6 \text{ k}\Omega$$

DP 16.2

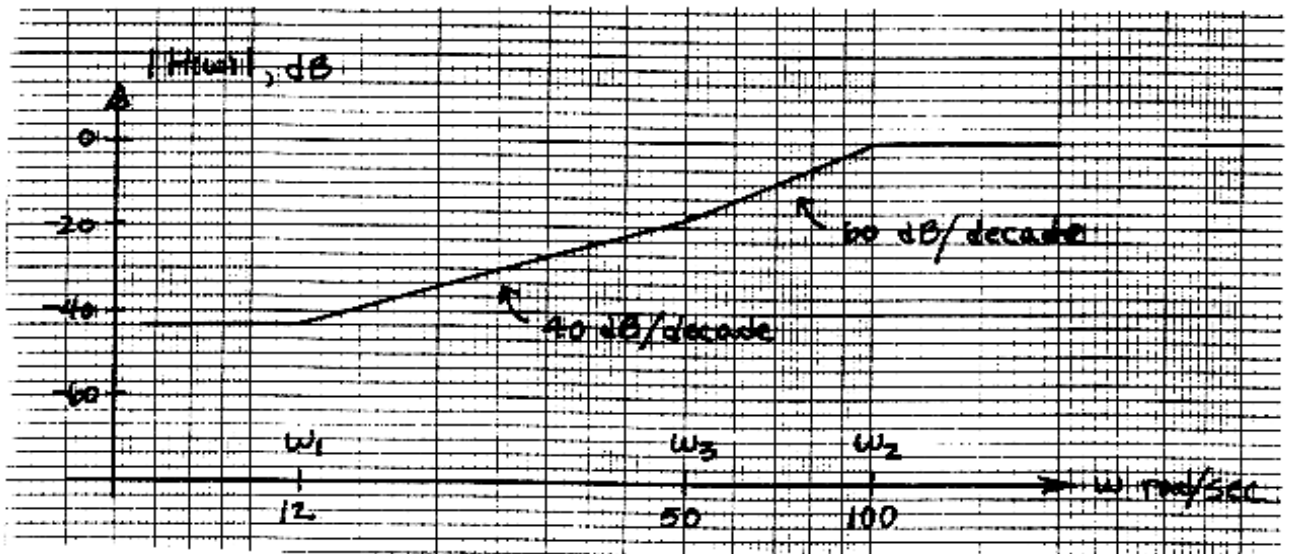

DP 16.3

Choose $\omega_1 = 0.1$, $\omega_2 = 2$, $\omega_3 = 5$, $\omega_4 = 100$ rad/s. The corresponding Bode magnitude plot is:

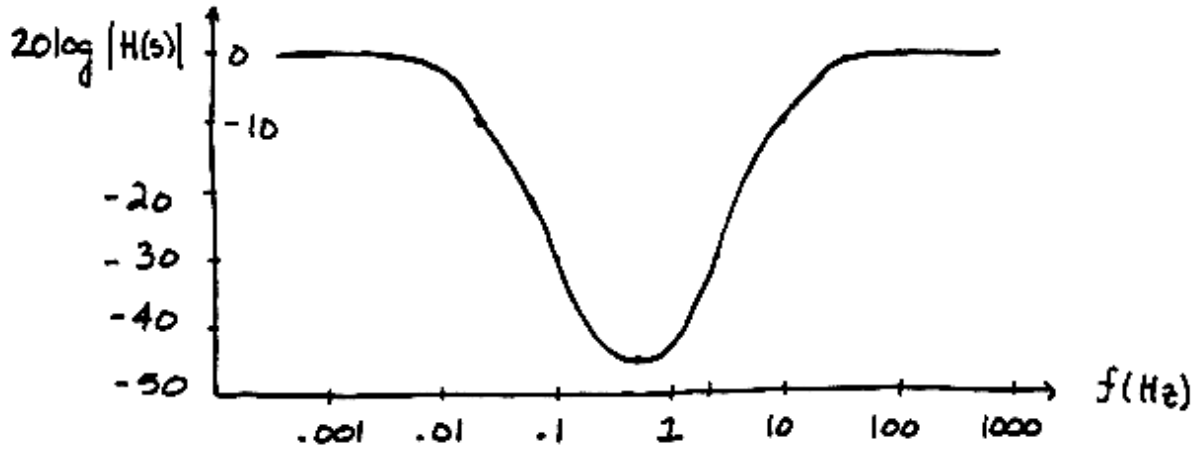

$$H(s) = \frac{\left(1 + \frac{s}{\omega_1}\right)^2 \left(1 + \frac{s}{\omega_3}\right)^2}{\left(1 + \frac{s}{\omega_2}\right)^2 \left(1 + \frac{s}{\omega_4}\right)^2}$$

Minimum gain is -46.2 dB at $f_{\min} = 0.505$ Hz

Chapter 17- Two-Port and Three Port Networks

Exercises

Ex. 17.4-1

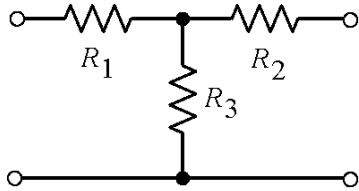

$$R_1 = \frac{R_a R_c}{R_a + R_b + R_c} = \frac{25(100)}{250} = 10 \Omega$$

$$R_2 = \frac{R_b R_c}{R_a + R_b + R_c} = \frac{(125)(125)}{250} = 12.5 \Omega$$

$$R_3 = \frac{R_a R_b}{R_a + R_b + R_c} = \frac{100(125)}{250} = 50 \Omega$$

Ex. 17.5-1

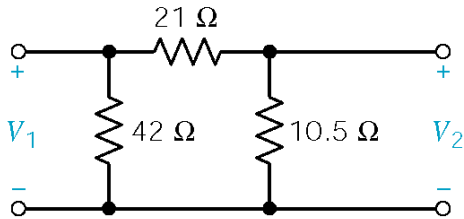

$$-Y_{12} = -Y_{21} = \frac{1}{21}$$

$$Y_{11} + Y_{12} = \frac{1}{42} \Rightarrow Y_{11} = \frac{1}{42} - \left(-\frac{1}{21}\right) = \frac{3}{42}$$

$$Y_{22} + Y_{21} = 10.5 \Rightarrow Y_{22} = \frac{1}{10.5} - \left(-\frac{1}{21}\right) = 1/7$$

$$\mathbf{Y} = \begin{bmatrix} \frac{1}{41} & -\frac{1}{21} \\ -\frac{1}{21} & \frac{1}{7} \end{bmatrix}$$

$$Z_{11} = \left. \frac{V_1}{I_1} \right|_{I_2=0} = \frac{42(21+10.5)}{42+31.5} = 18 \Omega$$

$$Z_{22} = \left. \frac{V_2}{I_2} \right|_{I_1=0} = \frac{10.5(63)}{73.5} = 9 \Omega$$

$$Z_{12} = Z_{21} = \left. \frac{V_1}{I_2} \right|_{I_1=0} = 6 \Omega$$

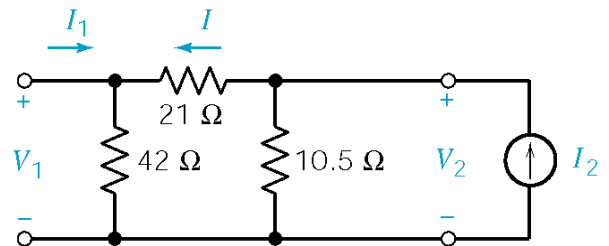

$$\text{Since } I = \frac{10.5}{73.5} I_2, \text{ then } V_1 = \frac{42(10.5)}{73.5} I_2 = 6 I_2 \Rightarrow Z = \begin{bmatrix} 18 & 6 \\ 6 & 9 \end{bmatrix}$$

Ex. 17.6-1

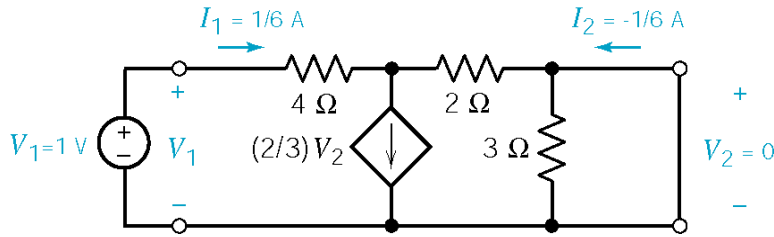

$$Y_{11} = \frac{I_1}{V_1} = \frac{1}{6}$$

$$Y_{21} = \frac{I_2}{V_1} = -\frac{1}{6} = -.167$$

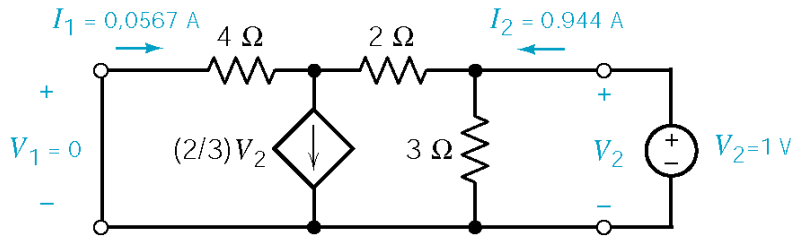

$$Y_{12} = \frac{I_1}{V_2} = 0.0567$$

$$Y_{22} = \frac{I_2}{V_2} = 0.944$$

Ex. 17.7-1

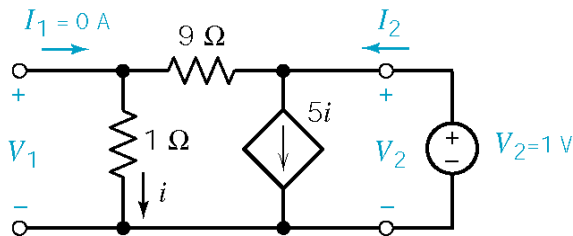

$$I_2 = 6i, \quad V_2 = (9+1)i = 10i, \quad V_1 = 1i$$

$$h_{22} = \frac{I_2}{V_2} = \frac{6i}{10i} = 0.6 \text{ S}$$

$$h_{12} = \frac{V_1}{V_2} = \frac{i}{10i} = 0.1$$

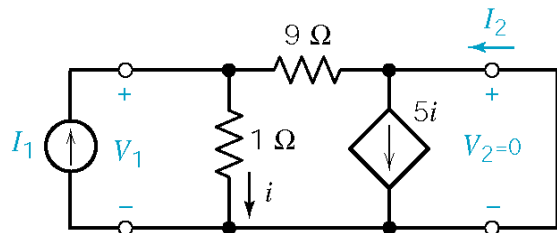

$$V_1 = 1i$$

$$I_1 = i + \frac{V_1}{9} = \frac{10}{9}i$$

$$I_2 = 5i - \frac{V_1}{9} = \frac{44}{9}i$$

Therefore

$$h_{11} = \frac{V_1}{I_1} = \frac{i}{\left(\frac{10}{9}\right)i} = 0.9 \Omega$$

$$h_{21} = \frac{I_2}{I_1} = \frac{\left(\frac{44}{9}\right)i}{\left(\frac{10}{9}\right)i} = 4.4$$

Ex. 17.8-1

$$\mathbf{Y} = \begin{bmatrix} 2/15 & -1/5 \\ -1/10 & 2/5 \end{bmatrix} \text{ and } \Delta\mathbf{Y} = \frac{4}{75} - \frac{1}{50} = \frac{1}{30} \text{ S} \Rightarrow \mathbf{Z} = 30 \begin{bmatrix} 2/5 & 1/5 \\ 1/10 & 2/15 \end{bmatrix} = \begin{bmatrix} 12 & 6 \\ 3 & 4 \end{bmatrix}$$

Ex. 17.8-2

$$\mathbf{T} = \begin{bmatrix} \frac{2/5}{(-1/10)} & \frac{1}{(-1/10)} \\ \frac{1/30}{(-1/10)} & \frac{2/15}{(-1/10)} \end{bmatrix} = \begin{bmatrix} 4 & 10 \\ 1/3 & 4/3 \end{bmatrix}$$

Ex. 17.9-1

$$\mathbf{T}_a = \begin{bmatrix} 1 & 12 \\ 0 & 1 \end{bmatrix}, \mathbf{T}_b = \begin{bmatrix} 1 & 0 \\ 1/6 & 1 \end{bmatrix} \text{ and } \mathbf{T}_c = \begin{bmatrix} 1 & 3 \\ 0 & 1 \end{bmatrix}$$

$$\mathbf{T}_a \mathbf{T}_b \mathbf{T}_c = \begin{bmatrix} 1 & 12 \\ 0 & 1 \end{bmatrix} \begin{bmatrix} 1 & 0 \\ 1/6 & 1 \end{bmatrix} \mathbf{T}_c = \begin{bmatrix} 3 & 12 \\ 1/6 & 1 \end{bmatrix} \begin{bmatrix} 1 & 3 \\ 0 & 1 \end{bmatrix} = \begin{bmatrix} 3 & 21 \\ 1/6 & 3/2 \end{bmatrix}$$

Problems

Section 17-4: T-to-T1 Transformations

P17.4-1

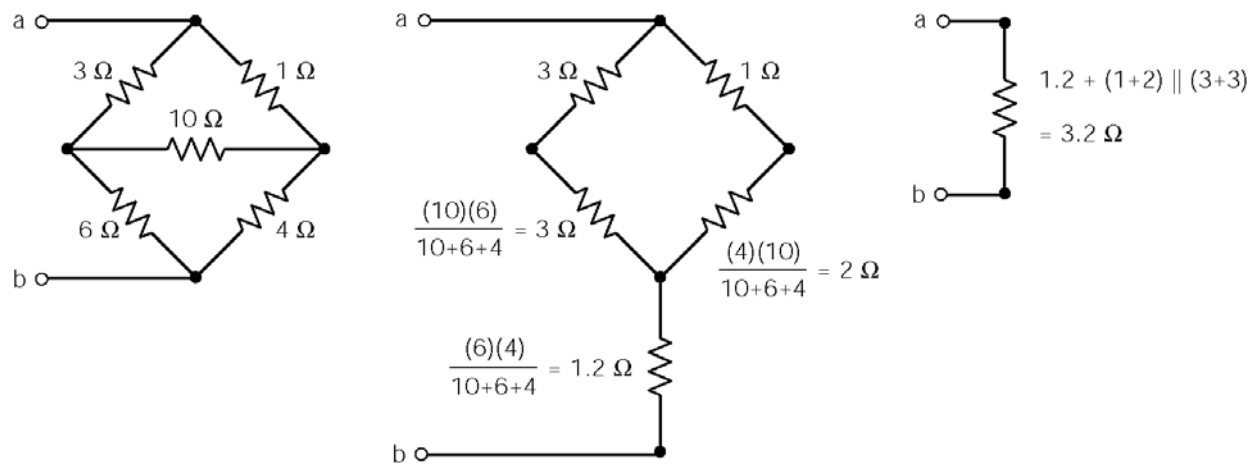

P17.4-2

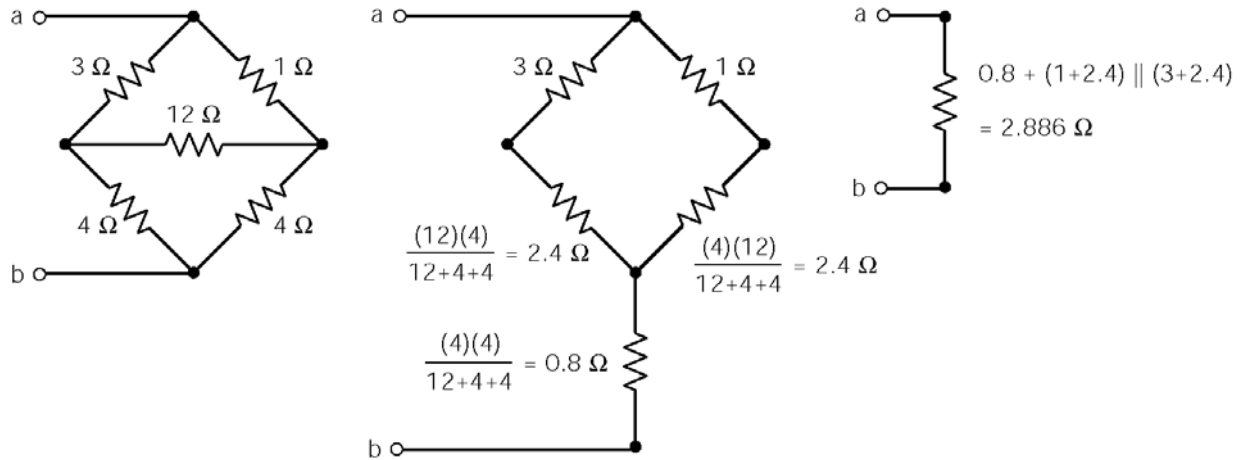

P17.4-3

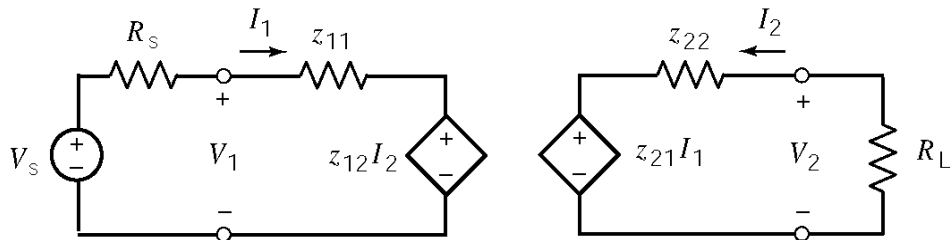

$$I_2 = \frac{-z_{21} I_1}{z_{22} + R_L} \Rightarrow A_i = \frac{-I_2}{I_1} = \frac{z_{21}}{z_{22} + R_L} \quad (\text{forward current gain})$$

$$R_{in} = \frac{V_1}{I_1} = \frac{z_{11} I_1 + z_{12} I_2}{I_1} = z_{11} - \frac{z_{12} A_i I_1}{I_1} = z_{11} - \frac{z_{12} z_{21}}{(z_{22} + R_L)} \quad (\text{input resistance})$$

$$V_2 = -I_2 R_L = A_i R_L I_1 \quad \text{and} \quad V_1 = R_{in} I_1 \Rightarrow A_v = \frac{V_2}{V_1} = \frac{A_i R_L}{R_{in}} \quad (\text{forward voltage gain})$$

$$\therefore A_p = A_i A_v = A_i^2 \frac{R_L}{R_{in}}$$

P17.4-4

First, simplify the circuit using a Δ -Y transformation:

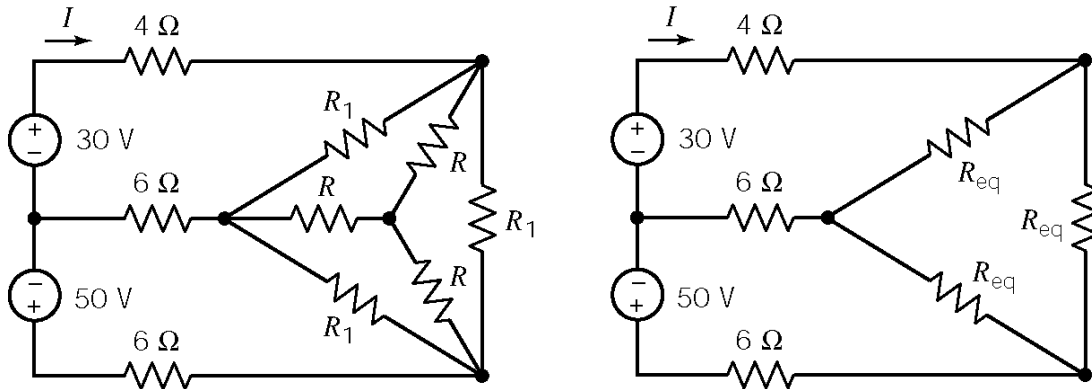

$$R_{eq} = R_1 \parallel \frac{R}{3} = 5 \parallel 20 = 4 \Omega$$

Mesh equations:

$$30 = 18I - 10I_2$$

$$50 = 10I - 20I_2$$

Solving for the required current:

$$I = \frac{\begin{vmatrix} 30 & -10 \\ 50 & -20 \end{vmatrix}}{18(-20) - (-10)10} = \frac{-100}{-260} = \underline{0.385 \text{ A}}$$

P17.4-5

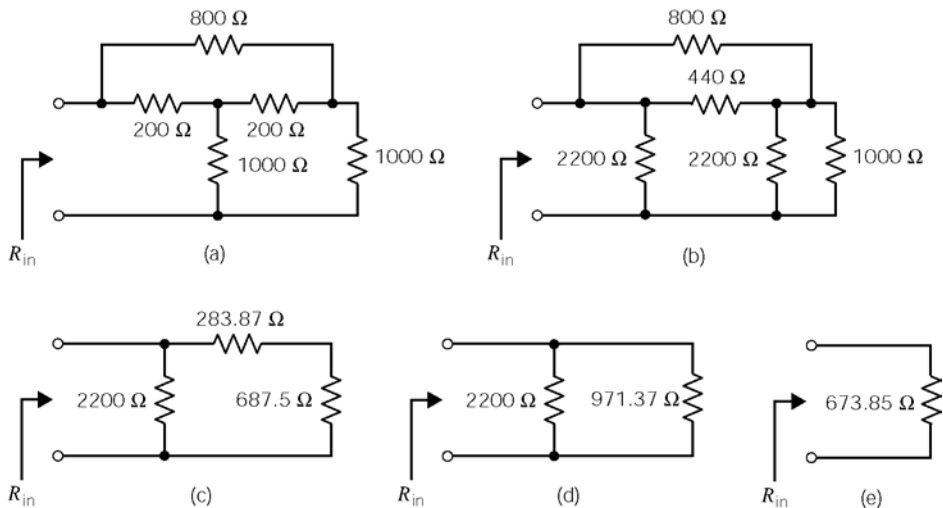

Section 17-5: Equations of Two-Port Networks

P17-5-1

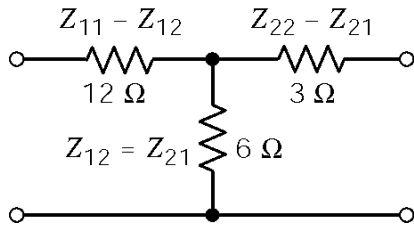

$$Z_{12} = 6\ \Omega$$

$$Z_{11} - Z_{12} = 12\ \Omega \Rightarrow Z_{11} = 18\ \Omega$$

$$Z_{22} - Z_{21} = 3\ \Omega \Rightarrow Z_{22} = 9\ \Omega$$

$$Y_{11} = \left. \frac{I_1}{V_1} \right|_{V_2=0} = \frac{1}{14}\ \text{S}$$

$$Y_{12} = \left. \frac{I_1}{V_2} \right|_{V_1=0} = \frac{-6 I_2}{(6+12) V_2} = -\frac{1}{21}\ \text{S} = Y_{21}$$

$$Y_{22} = \left. \frac{I_2}{V_2} \right|_{V_1=0} = \frac{V_2/7}{V_2} = \frac{1}{7}\ \text{S}$$

$$\mathbf{Y} = \begin{bmatrix} 1/14 & -1/21 \\ -1/21 & 1/7 \end{bmatrix}$$

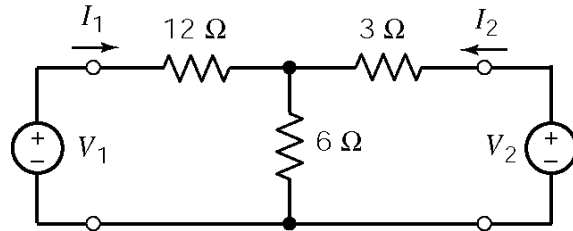

P17.5-2

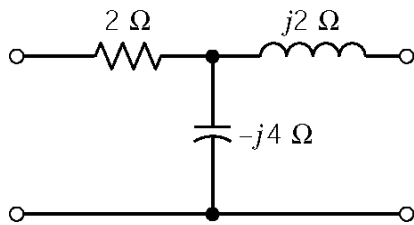

$$\mathbf{Z} = \begin{bmatrix} 2-j4 & -j4 \\ -j4 & +j2 \end{bmatrix}$$

P17.5-3

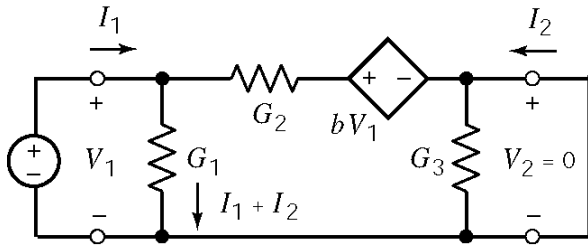

$$Y_{11} = \left. \frac{I_1}{V_1} \right|_{V_2=0} \quad \text{and} \quad Y_{21} = \left. \frac{I_2}{V_1} \right|_{V_2=0}$$

$$V_1 = \frac{I_1 + I_2}{G_1} \quad \text{and} \quad \frac{I_1 + I_2}{G_1} + \frac{I_2}{G_2} = bV_1$$

so

$$I_1 = (G_1 - (b-1)G_2)V_1 = -1V_1 \quad \text{and} \quad I_2 = (b-1)G_2V_1 = 3V_1$$

Finally

$$Y_{11} = -1 \text{ S} \quad \text{and} \quad Y_{21} = 3 \text{ S}$$

Next

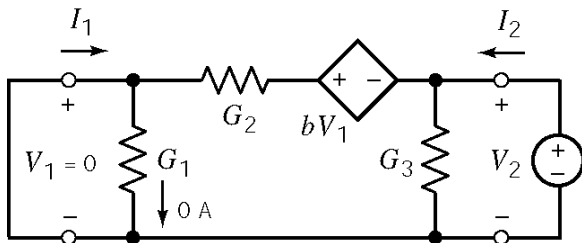

$$V_2 = \frac{I_1 + I_2}{G_3} \quad \text{and} \quad V_2 = \frac{-I_2}{G_2}$$

$$Y_{12} = \left. \frac{I_1}{V_2} \right|_{V_1=0} = -G_2 = -1 \text{ S}$$

$$Y_{22} = \left. \frac{I_2}{V_2} \right|_{V_1=0} = G_2 + G_3 = 4 \text{ S}$$

P17.5-4

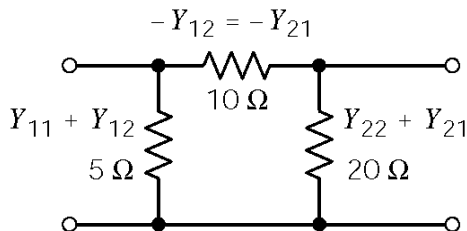

Using Fig. 17.5-2 as shown:

$$-Y_{12} = -Y_{21} = 0.1 \text{ S} \quad \text{or} \quad Y_{12} = Y_{21} = -0.1 \text{ S}$$

$$Y_{11} = 0.2 - Y_{12} = 0.3 \text{ S}$$

$$Y_{22} = 0.05 - Y_{21} = 0.15 \text{ S}$$

P17.5-5

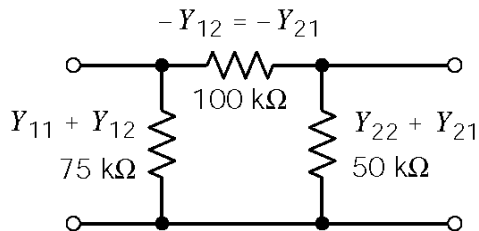

$$Y_{12} = -10 \mu\text{S} = Y_{21}$$

$$Y_{11} + Y_{12} = 13.33 \mu\text{S}$$

$$Y_{11} = 23.33 \mu\text{S}$$

$$Y_{22} + Y_{21} = 20 \mu\text{S} \quad \Rightarrow \quad Y_{22} = 30 \mu\text{S}$$

P17.5-6

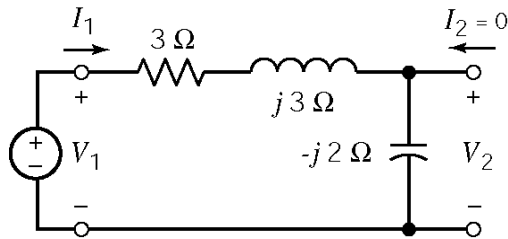

$$Z_{11} = \left. \frac{V_1}{I_1} \right|_{I_2=0} = 3 + j3 - j2 = (3+j) \Omega$$

$$Z_{21} = \left. \frac{V_2}{I_1} \right|_{I_2=0} = \frac{-j2 I_1}{I_1} = -j2 \Omega$$

$$Z_{12} = \left. \frac{V_1}{I_2} \right|_{I_1=0} = -j2 \Omega$$

$$Z_{22} = \left. \frac{V_2}{I_2} \right|_{I_1=0} = -j2 \Omega$$

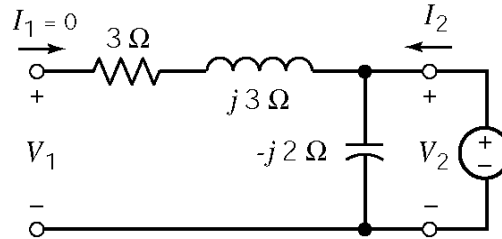

P17.5-7

$$\left. \begin{aligned} Z_{11} - Z_{21} &= 4 \\ Z_{21} - Z_{12} &= 1/s \end{aligned} \right\} \Rightarrow Z_{11} = 4 + 1/s = \frac{4s+1}{s}$$

$$Z_{22} - Z_{21} = 2s \Rightarrow Z_{22} = 2s + 1/s = \frac{2s^2+1}{s}$$

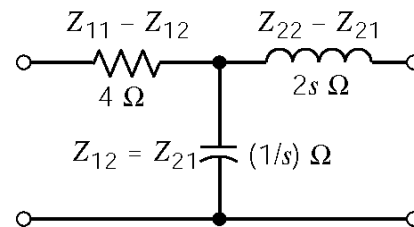

P17.5-8

Given:

$$\mathbf{Y} = \begin{bmatrix} \frac{s+1}{s} & -1 \\ -1 & s+1 \end{bmatrix}$$

Try a π circuit as shown at the right.

$$Y_{12} = -1s$$

$$Y_{11} = \frac{s+1}{s} \Rightarrow Y_{11} + Y_{12} = \frac{s+1}{s} - 1 = \frac{1}{s}$$

$$Y_{22} + Y_{21} = (s+1) - 1 = s$$

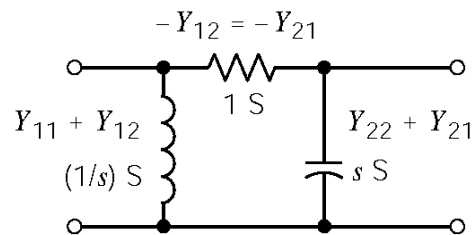

P17.5-9

Given:

$$\mathbf{Z} = \begin{bmatrix} \frac{s^2+2s+2}{s^2+s+1} & \frac{1}{s^2+s+1} \\ \frac{1}{s^2+s+1} & \frac{s^2+1}{s^2+s+1} \end{bmatrix}$$

Try :

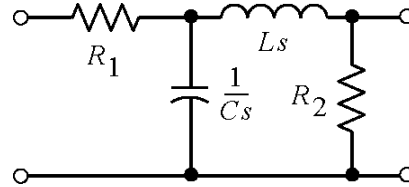

From the circuit, we calculate:

$$z_{11} = R_1 + \frac{\frac{1}{Cs}(R_2 + Ls)}{\frac{1}{Cs} + R_2 + Ls} = R_1 + \frac{R_2 + Ls}{1 + R_2 Cs + LCs^2} = \frac{LCR_1 s^2 + (R_1 R_2 C + L)s + R_1 + R_2}{LCs^2 + R_2 Cs + 1}$$

Comparing to the given z_{11} yields:

$$\left. \begin{array}{l} LC = 1 \\ R_2 C = 1 \\ LC R_1 = 1 \\ R_1 R_2 C + L = 2 \\ R_1 + R_2 = 2 \end{array} \right\} \Rightarrow \begin{cases} R_1 = 1 \Omega \\ R_2 = 1 \Omega \\ L = 1 \text{ H} \\ C = 1 \text{ F} \end{cases}$$

Then check z_{12} , z_{21} and z_{22} . They are all okay. If they were not, we would have to try a different circuit structure..

P17.5-10

It is sufficient to require that the input resistance of each section of the circuit is equal to R_o , that is

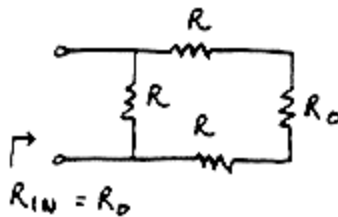

Then

$$R_o = \frac{R(2R+R_o)}{3R+R_o} \Rightarrow R_o = R \pm \sqrt{4R^2 + 4(2R^2)} = R \pm \sqrt{3R} = \underline{(\sqrt{3}-1)R}$$

Section 17-6: Z and Y Parameters

P17.6-1

$$i = -\frac{V_1}{R_1} \text{ and } I_2 = -\frac{(b + R_1)}{R_1 R_2} V_1$$

$$I_1 = -I_2 - i = \left(\frac{b + R_1 + R_2}{R_1 R_2} \right) V_1$$

$$Y_{11} = \left. \frac{I_1}{V_1} \right|_{V_2=0} = \frac{b + R_1 + R_2}{R_1 R_2} \text{ and } Y_{21} = \left. \frac{I_2}{V_1} \right|_{V_2=0} = -\frac{(b + R_1)}{R_1 R_2}$$

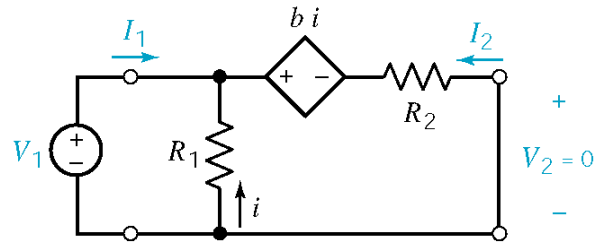

$$I_2 = -I_1$$

$$V_2 = R_2 I_2 \Rightarrow I_2 = \frac{V_2}{R_2}$$

$$Y_{22} = \left. \frac{I_2}{V_2} \right|_{V_1=0} = \frac{1}{R_2} \text{ and } Y_{12} = \left. \frac{I_1}{V_2} \right|_{V_1=0} = -\frac{1}{R_2}$$

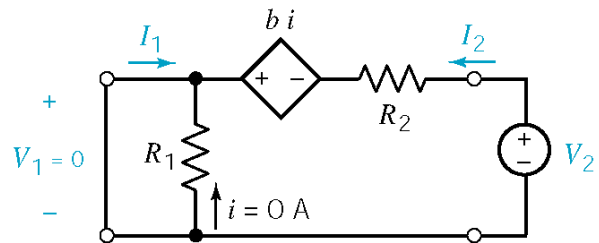

P17.6-2

$$i_2 = 0 \Rightarrow \begin{cases} v_1 = (1+3)i_1 = 4i_1 \\ v_2 = 3i_1 \end{cases}$$

therefore

$$z_{11} = 4 \Omega \text{ and } z_{21} = 3 \Omega$$

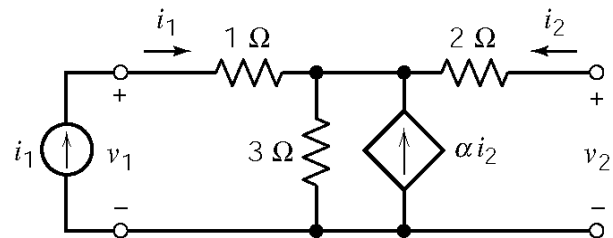

$$i_1 = 0 \Rightarrow \begin{cases} v_1 = 3(\alpha i_2 + i_2) \\ v_1 = 3(\alpha i_2 + i_2) + 2i_2 \end{cases}$$

therefore

$$z_{12} = 3(1+\alpha) \text{ and } z_{21} = 5+3\alpha$$

Finally,

$$\mathbf{Z} = \begin{bmatrix} 4 & 3(1+\alpha) \\ 3 & 5+3\alpha \end{bmatrix}$$

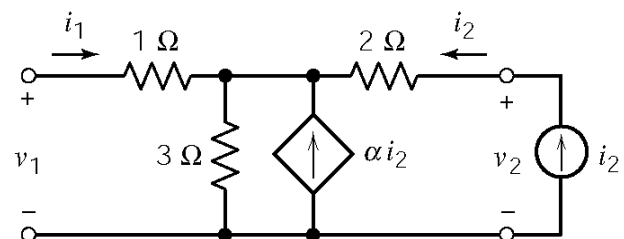

P17.6-3

Treat the circuit as the parallel connection of two 2-port networks:

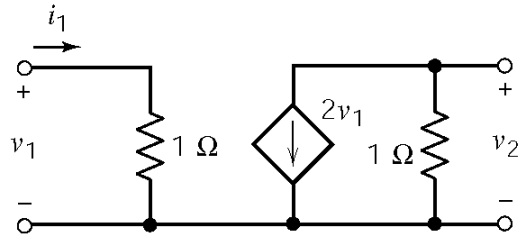

The admittance matrix of the entire network can be obtained as the sum of the admittance matrices of these two 2-port networks

$$\mathbf{Y} = \begin{bmatrix} 1 & 0 \\ 2 & 1 \end{bmatrix} + \begin{bmatrix} 2s & -s \\ -s & 2s \end{bmatrix} = \begin{bmatrix} 1+2s & -s \\ 2-s & 1+2s \end{bmatrix}$$

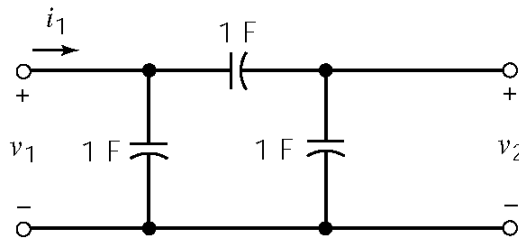

When $i_1(t) = u(t)$:

$$\mathbf{Y} \begin{bmatrix} V_1(s) \\ V_2(s) \end{bmatrix} = \begin{bmatrix} \frac{1}{s} \\ 0 \end{bmatrix} \Rightarrow \begin{bmatrix} V_1(s) \\ V_2(s) \end{bmatrix} = \mathbf{Y}^{-1} \begin{bmatrix} \frac{1}{s} \\ 0 \end{bmatrix} = \frac{\begin{bmatrix} 2s+1 & s \\ s-2 & 2s+1 \end{bmatrix}}{3s^2+6s+1} \begin{bmatrix} \frac{1}{s} \\ 0 \end{bmatrix}$$

so

$$V_2(s) = \frac{(s-2)}{s(3s^2+6s+1)} = \frac{1}{3} \left[\frac{-6}{s} + \frac{-1.25}{s+1.82} + \frac{7.25}{s+0.184} \right]$$

Taking the inverse Laplace transform

$$\underline{v_2(t) = \frac{1}{3} \left[-6 - 1.25e^{-1.82t} + 7.25e^{-0.184t} \right] \quad t \geq 0}$$

P17.6-4

KVL: $\frac{1}{2}(i_1 - v_1) + 2v_2 + v_2 - v_1 = 0$

KCL: $i_1 - v_1 = 4v_1 + 2v_2$

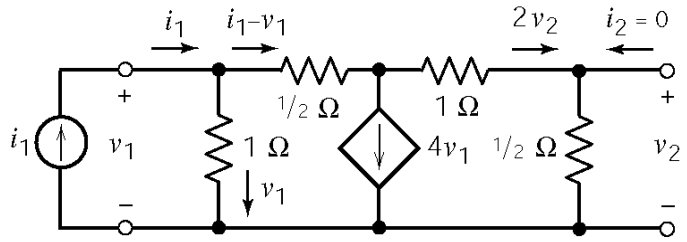

$$\left. \begin{array}{l} i_1 = 3v_1 - 6v_2 \\ i_1 = 5v_1 + 2v_2 \end{array} \right\} \Rightarrow \begin{cases} i_1 = 3v_1 - 6 \frac{i_1 - 5v_1}{2} \Rightarrow z_{11} = \frac{v_1}{i_1} = \frac{2}{9} \Omega \\ i_1 = 5 \frac{i_1 + 6v_2}{3} + 2v_2 \Rightarrow z_{21} = \frac{v_2}{i_1} = -\frac{1}{18} \Omega \end{cases}$$

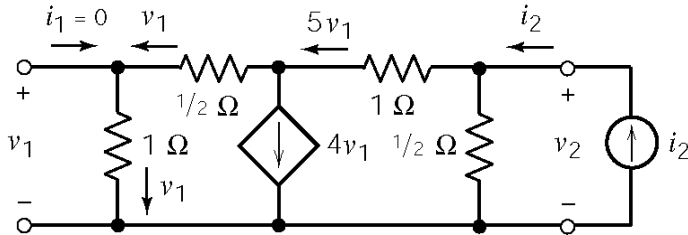

KVL: $v_2 = 1v_1 + \frac{1}{2}v_1 + 5v_1 = \frac{13}{2}v_1$

KCL: $i_2 = \frac{v_2}{1/2} + 5v_1 = 2v_2 + 5v_1$

$$i_2 = 2 \left(\frac{13}{2} v_1 \right) + 5 v_1 = 18 v_1 \Rightarrow z_{12} = \frac{1}{18} \Omega$$

and

$$i_2 = 2 v_2 + 5 \left(\frac{2}{13} v_2 \right) = 2.769 v_2 \Rightarrow z_{22} = 0.361 \Omega$$

P17.6-5

$$\text{KCL: } i_1 + i_2 = \frac{v_1}{R_1}$$

$$\text{KVL: } -R_2 i_2 - b v_1 + 0 - v_1 = 0$$

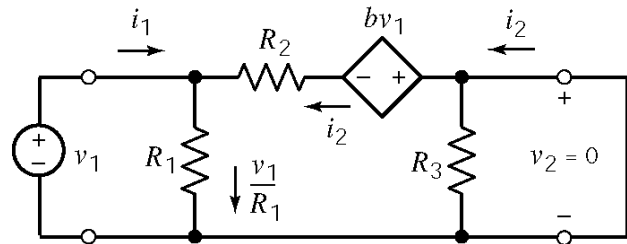

Then

$$i_2 = -\frac{b+1}{R_2} v_1 \quad \text{and} \quad i_1 = \left(\frac{1}{R_1} + \frac{b+1}{R_2} \right) v_1 = \frac{R_2 + R_1(b+1)}{R_1 R_2} v_1$$

so

$$y_{21} = \frac{i_2}{v_1} = -\frac{b+1}{R_2} \quad \text{and} \quad y_{11} = \frac{i_1}{v_1} = \frac{R_2 + R_1(b+1)}{R_1 R_2}$$

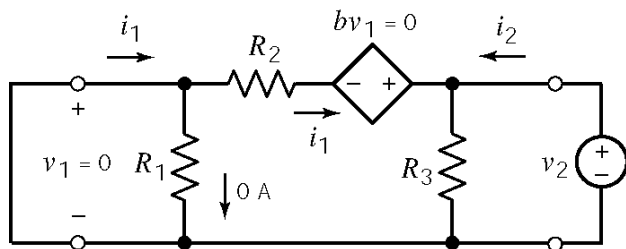

$$\text{KVL: } R_2 i_1 + v_2 = 0 \Rightarrow i_1 = -\frac{1}{R_2} v_2$$

$$\text{KCL: } v_2 = R_3 (i_1 + i_2) = R_3 \left(-\frac{1}{R_2} v_2 \right) + R_3 i_2$$

Then

$$y_{12} = \frac{i_1}{v_2} = -\frac{1}{R_2} \quad \text{and} \quad v_2 \left(1 + \frac{R_3}{R_2} \right) = R_3 i_2 \Rightarrow y_{22} = \frac{i_2}{v_2} = \frac{1}{R_3} + \frac{1}{R_2}$$

Section 17-7: Hybrid Transmission Parameters

17.7-1

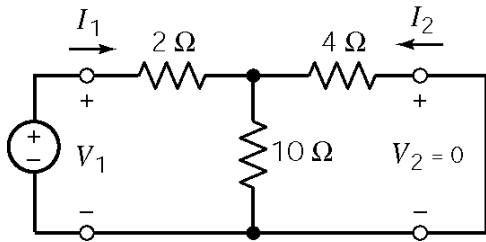

$$B = \left. \frac{V_1}{-I_2} \right|_{V_2=0} = \frac{34}{5} = 6.8 \Omega \quad \text{since} \quad -I_2 = \frac{V_1}{2+4 \parallel 10} = \frac{5}{34} V_1$$

$$D = \left. \frac{I_1}{-I_2} \right|_{V_2=0} = \frac{10+4}{10} = 1.4 \quad \text{since} \quad I_2 = -\frac{10}{10+4} I_1$$

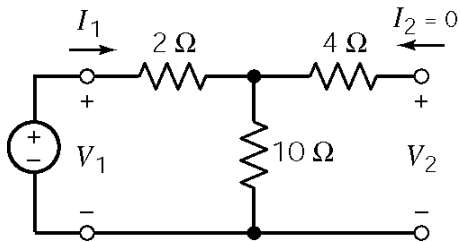

$$A = \left. \frac{V_1}{V_2} \right|_{I_2=0} = \frac{12}{10} = 1.2 \quad \text{since} \quad V_2 = \frac{10}{10+2} V_1$$

$$C = \left. \frac{I_1}{V_2} \right|_{I_2=0} = \frac{1}{10} = 0.1 \text{ S}$$

17.7-2

$$V_2 = 0$$

so

$$V_1 = (R_1 + R_1 \parallel R_2) I_1$$

therefore

$$h_{11} = \left. \frac{V_1}{I_1} \right|_{V_2=0} = R_1 + R_1 \parallel R_2 = 600 \text{ k}\Omega$$

KVL:

$$I_2 + \frac{R_1}{R_1+R_2} I_1 = -A \frac{R_1}{R_0} I_1$$

therefore

$$h_{21} = \left. \frac{I_2}{I_1} \right|_{V_2=0} = -\left(A \frac{R_1}{R_0} + \frac{R_1}{R_1+R_2} \right) = -10^6$$

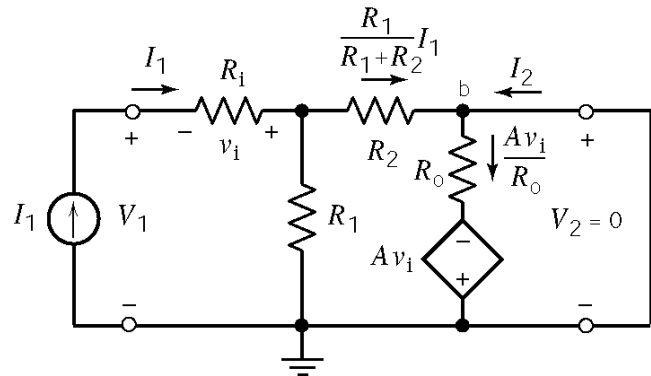

$$I_1 = 0 \Rightarrow v_i = 0 \Rightarrow Av_i = 0$$

so

$$I_2 = \frac{V_2}{R_o \parallel (R_1 + R_2)}$$

therefore

$$h_{22} = \frac{I_2}{V_2} \Big|_{I_1=0} = \frac{R_o + R_1 + R_2}{R_o(R_1 + R_2)} = 10^{-3}$$

Next,

$$V_1 = \frac{R_1}{R_1 + R_2} V_2$$

therefore

$$h_{12} = \frac{V_1}{V_2} \Big|_{I_1=0} = \frac{R_1}{R_1 + R_2} = \frac{1}{2}$$

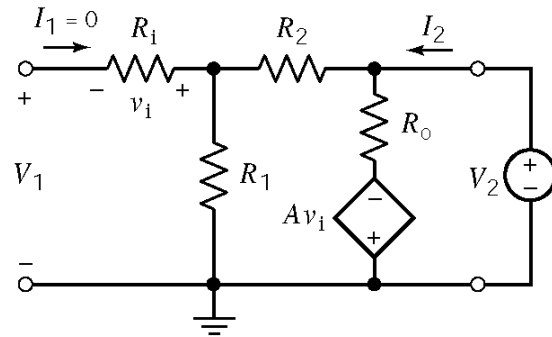

P17.7-3

	<p>Compare :</p> $V_2 = n V_1$ $I_1 = -n I_2$	<p>to</p> $V_1 = h_{11} I_1 + h_{12} V_2$ $I_2 = h_{21} I_1 + h_{22} V_2$
--	---	---

Then $h_{11} = 0$, $h_{22} = 0$, $h_{12} = 1/n$ and $h_{21} = 1/-n$

P17.7-4

	$V_1 = (R_1 + R_2 \parallel R_3) I_1 \Rightarrow h_{11} = R_1 + \frac{R_2 R_3}{R_2 + R_3}$ $I_2 = -\frac{R_2}{R_2 + R_3} I_1 \Rightarrow h_{21} = -\frac{R_2}{R_2 + R_3}$
--	---

	$I_2 = \frac{V_2}{R_2 + R_3} \Rightarrow h_{22} = \frac{1}{R_2 + R_3}$ $V_1 = \frac{R_2}{R_2 + R_3} V_2 \Rightarrow h_{12} = \frac{R_2}{R_2 + R_3}$
--	---

P17.7-5

	$I_2 = 0.1v \text{ and } v = 950 I_1$ $\text{so } I_2 = 95 I_1$ $h_{11} = \left. \frac{V_1}{I_1} \right _{V_2=0} = 50 + 950 = 1000 \Omega$ $h_{21} = \left. \frac{I_2}{I_1} \right _{V_2=0} = 95$
--	---

$I_1 = 0 \Rightarrow v = 0$ $h_{12} = \left. \frac{V_1}{V_2} \right _{I_1=0} = 0$ $h_{22} = \left. \frac{I_2}{V_2} \right _{I_1=0} = 10^{-4} \text{ S}$	
---	--

Section 17-8: Relationships between Two-Port Parameters

P17.8-1

Start with

$$\text{Y parameters: } \begin{cases} I_1 = Y_{11} V_1 + Y_{12} V_2 \\ I_2 = Y_{21} V_1 + Y_{22} V_2 \end{cases} \quad \text{and} \quad \text{H parameters: } \begin{cases} V_1 = h_{11} I_1 + h_{12} V_2 \\ I_2 = h_{21} I_1 + h_{22} V_2 \end{cases}$$

Solve the Y parameter equations for V_1 and I_2 to put them in the same form as the H parameter equations.

$$\begin{aligned} -Y_{11} V_1 &= I_1 + Y_{12} V_2 \\ -Y_{21} V_1 + I_2 &= Y_{22} V_2 \end{aligned} \Rightarrow \begin{bmatrix} -Y_{11} & 0 \\ -Y_{21} & 1 \end{bmatrix} \begin{bmatrix} V_1 \\ I_2 \end{bmatrix} = \begin{bmatrix} -1 & Y_{12} \\ 0 & Y_{22} \end{bmatrix} \begin{bmatrix} -I_1 \\ V_2 \end{bmatrix} \Rightarrow \begin{bmatrix} V_1 \\ I_2 \end{bmatrix} = \begin{bmatrix} -Y_{11} & 0 \\ -Y_{21} & 1 \end{bmatrix}^{-1} \begin{bmatrix} -1 & Y_{12} \\ 0 & Y_{22} \end{bmatrix} \begin{bmatrix} -I_1 \\ V_2 \end{bmatrix}$$

$$\therefore \mathbf{H} = \begin{bmatrix} -Y_{11} & 0 \\ -Y_{21} & 1 \end{bmatrix}^{-1} \begin{bmatrix} -1 & Y_{12} \\ 0 & Y_{22} \end{bmatrix} = \begin{bmatrix} -\frac{1}{Y_{11}} & 0 \\ \frac{Y_{21}}{Y_{11}} & 1 \end{bmatrix} \begin{bmatrix} -1 & Y_{12} \\ 0 & Y_{22} \end{bmatrix} = \begin{bmatrix} \frac{1}{Y_{11}} & -\frac{Y_{12}}{Y_{11}} \\ \frac{Y_{21}}{Y_{11}} & Y_{22} - \frac{Y_{12} Y_{21}}{Y_{11}} \end{bmatrix}$$

P17.8-2

First $\Delta Z = (3)(6) - (2)(2) = 14$. Then $\mathbf{Y} = \begin{bmatrix} \frac{Z_{22}}{\Delta Z} & -\frac{Z_{12}}{\Delta Z} \\ -\frac{Z_{21}}{\Delta Z} & \frac{Z_{11}}{\Delta Z} \end{bmatrix} = \begin{bmatrix} \frac{6}{14} & -\frac{2}{14} \\ -\frac{2}{14} & \frac{3}{14} \end{bmatrix}$.

P17.8-3

First $\Delta Y = (0.1)(0.5) - (0.4)(0.1) = .01$ S. Then $\mathbf{H} = \begin{bmatrix} \frac{1}{Y_{11}} & -\frac{Y_{12}}{Y_{11}} \\ \frac{Y_{21}}{Y_{11}} & \frac{\Delta Y}{Y_{11}} \end{bmatrix} = \begin{bmatrix} 10 & -1 \\ 4 & 0.1 \end{bmatrix}$.

P17.8-4

First $\Delta Y = (0.5)(0.6) - (-0.4)(-0.4)$ S. Then $\mathbf{H} = \begin{bmatrix} \frac{1}{Y_{11}} & -\frac{Y_{12}}{Y_{11}} \\ \frac{Y_{21}}{Y_{11}} & \frac{\Delta Y}{Y_{11}} \end{bmatrix} = \begin{bmatrix} 2 & 0.8 \\ -0.8 & 0.28 \end{bmatrix}$

Section 17-9: Interconnection of Two-Port Networks

P17.9-1

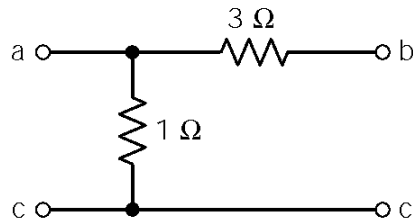

$$\begin{aligned} Y_{12} &= Y_{21} = -\frac{1}{3} \text{ S} \\ Y_{22} &= 0 - Y_{21} = \frac{1}{3} \text{ S} \\ Y_{11} + Y_{12} &= 1 \text{ S} \Rightarrow Y_{11} = \frac{4}{3} \text{ S} \end{aligned}$$

$$\mathbf{Y}_a = \begin{bmatrix} \frac{4}{3} & -\frac{1}{3} \\ -\frac{1}{3} & \frac{1}{3} \end{bmatrix}$$

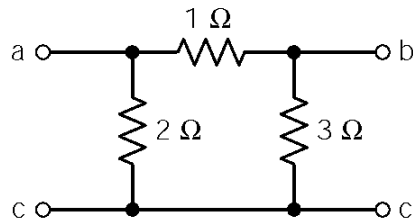

$$\begin{aligned} Y_{12} &= Y_{21} = -1 \text{ S} \\ Y_{11} + Y_{12} &= \frac{1}{2} \text{ S} \Rightarrow Y_{11} = \frac{3}{2} \text{ S} \\ Y_{21} + Y_{22} &= \frac{1}{3} \text{ S} \Rightarrow Y_{22} = \frac{4}{3} \text{ S} \end{aligned}$$

$$\mathbf{Y}_b = \begin{bmatrix} \frac{3}{2} & -1 \\ -1 & \frac{4}{3} \end{bmatrix}$$

$$\mathbf{Y} = \begin{bmatrix} (\frac{4}{3} + \frac{3}{2}) & -\frac{4}{3} \\ -\frac{4}{3} & \frac{5}{3} \end{bmatrix} = \begin{bmatrix} \frac{17}{6} & -\frac{4}{3} \\ -\frac{4}{3} & \frac{5}{3} \end{bmatrix}$$

P17.9-2

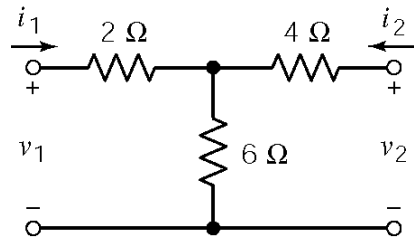

Admittance parameters:

$$\mathbf{Y} = \begin{bmatrix} \frac{10}{44} & \frac{-6}{44} \\ \frac{-6}{44} & \frac{8}{44} \end{bmatrix}$$

Transmission parameters:

$$\mathbf{T} = \begin{bmatrix} \frac{8}{6} & \frac{44}{6} \\ \frac{1}{6} & \frac{10}{6} \end{bmatrix}$$

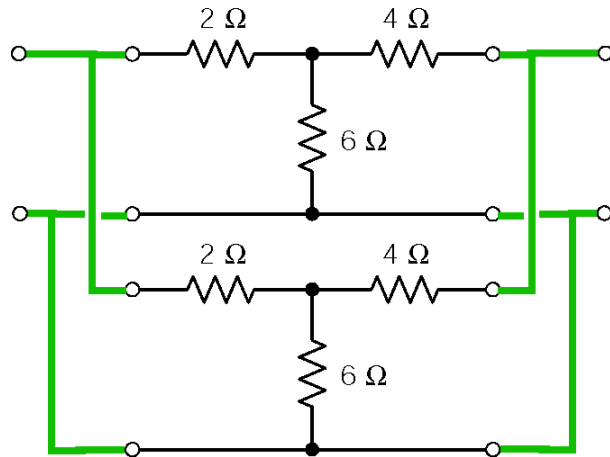

$$\mathbf{Y}_p = \mathbf{Y} + \mathbf{Y} = \begin{bmatrix} \frac{20}{44} & \frac{-12}{44} \\ \frac{-12}{44} & \frac{16}{44} \end{bmatrix}$$

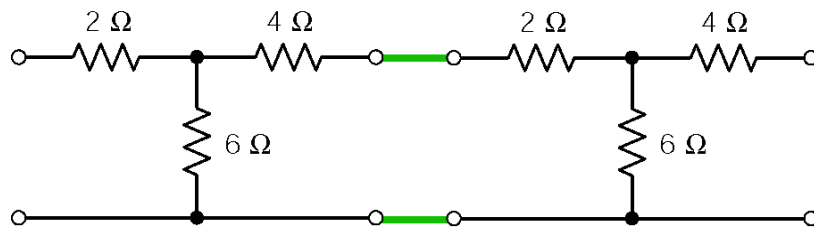

$$\mathbf{T}_c = \mathbf{T} \cdot \mathbf{T}' = \begin{bmatrix} \frac{108}{36} & \frac{792}{36} \\ \frac{18}{36} & \frac{144}{36} \end{bmatrix}$$

P17.9-3

$$\mathbf{Y} = \begin{bmatrix} \frac{1}{s} + s & -s \\ -s & \frac{1}{s} + s \end{bmatrix} + \begin{bmatrix} G_1 + G_2 & -G_2 \\ -G_2 & G_2 + G_3 \end{bmatrix}$$

Verification Problems

VP 17-1

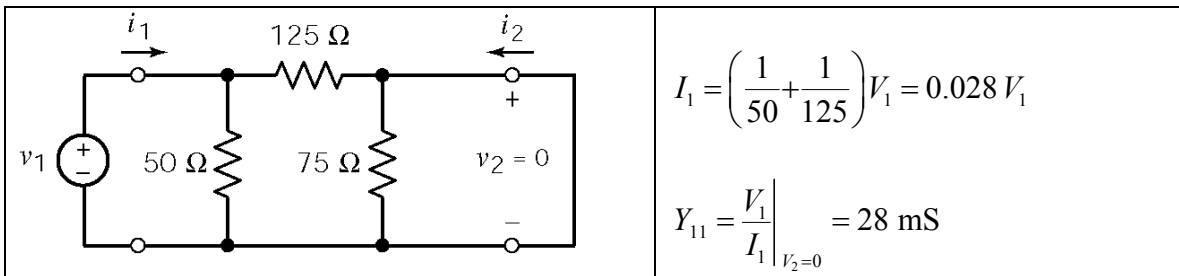
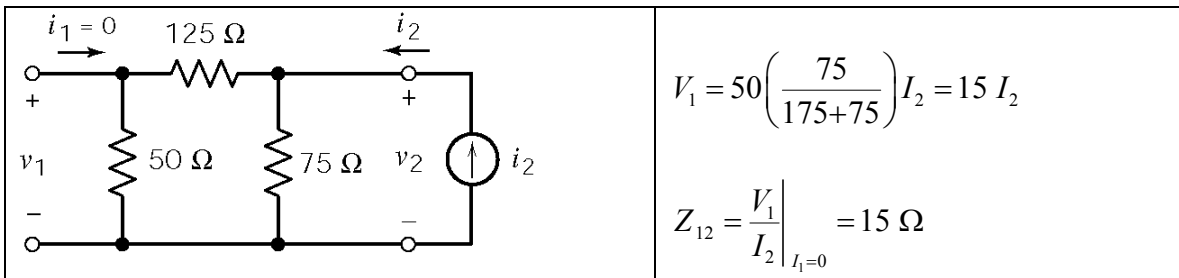

$Y_{11} \neq 24 \text{ mS}$, so the report is not correct.

VP 17-2

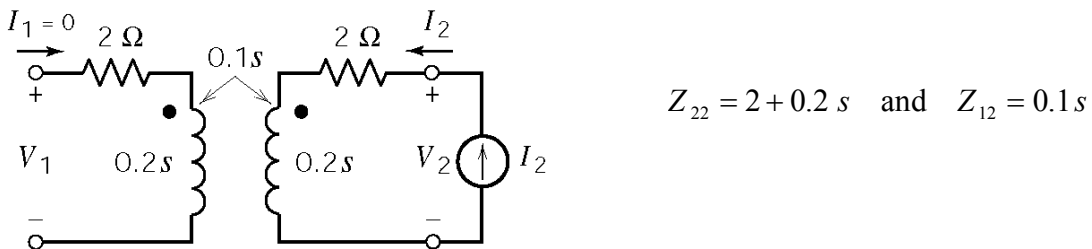
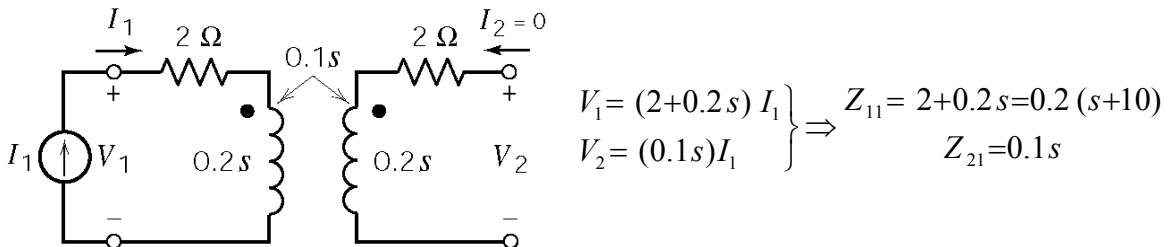

$$\Delta \mathbf{Z} = (2 + 0.2s)(2 + 0.2s) - (0.1s)(0.1s) = 0.01(3s^2 + 80s + 40)$$

$$\mathbf{T} = \begin{bmatrix} \frac{Z_{11}}{Z_{21}} & \frac{\Delta Z}{Z_{21}} \\ \frac{1}{Z_{21}} & \frac{Z_{22}}{Z_{21}} \end{bmatrix} = \begin{bmatrix} \frac{2(s+10)}{s} & \frac{0.1(3s^2+80s+40)}{s} \\ 0.1s & \frac{2(s+10)}{s} \end{bmatrix}$$

This is not the transmission matrix given in the report.

Design Problems

DP 17-1

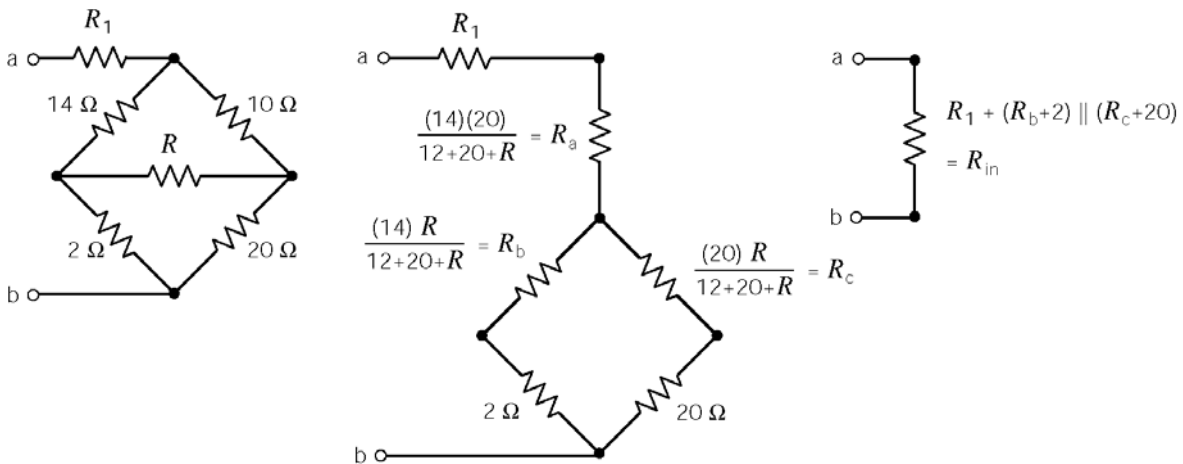

We will need to find R and R_1 by trial and error. A Mathcad spreadsheet will help with the calculations. Given the restrictions $R \leq 10\ \Omega$ and $R_1 \leq 10\ \Omega$ we will start with $R = 10\ \Omega$ and $R_1 = 10\ \Omega$:

$$\begin{aligned} R_1 &:= 10 & R &:= 10 \\ R_a &:= \frac{14 \cdot 20}{14 + 20 + R} & R_b &:= \frac{14 \cdot R}{14 + 20 + R} & R_c &:= \frac{R \cdot 20}{14 + 20 + R} \\ R_{in} &:= R_1 + \frac{(R_b + 2) \cdot (R_c + 20)}{R_b + 2 + R_c + 20} & R_{in} &= 14.279 \end{aligned}$$

The specifications cannot be satisfied. R and R_1 are at their maximum values but R_{in} needs to be larger. Reducing either R or R_1 will reduce R_{in} .

DP 17-2

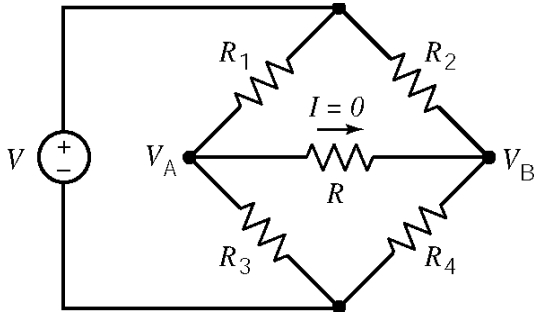

Need $V_A + V_B$ for balance

$$\frac{R_1 V}{R_1 + R_3} = \frac{R_2 V}{R_2 + R_4} \quad (1)$$

$$\frac{R_3 V}{R_1 + R_3} = \frac{R_4 V}{R_2 + R_4} \quad (2)$$

Dividing (1) by (2) yields: $\frac{R_1}{R_3} = \frac{R_2}{R_4}$

DP 17-3

$$V_1 = h_{11} I_1 + h_{12} V_2 \quad \text{and} \quad V_2 = -I_2 R_L \Rightarrow I_2 = h_{21} I_1 - h_{22} R_L I_2$$

$$I_2 = h_{21} I_1 + h_{22} V_2$$

Next

$$\frac{I_2}{I_1} = h_{21} \left(\frac{1}{1 + h_{22} R_L} \right) \Rightarrow A_i = \frac{I_L}{I_1} = -\frac{I_2}{I_1} = -h_{21} \left(\frac{1}{1 + h_{22} R_L} \right)$$

We require

$$79 = 80 \left(\frac{1}{1 + h_{22} R_L} \right) \Rightarrow \frac{79}{80} \left(1 + \frac{R_L}{80 \times 10^3} \right) = 1 \Rightarrow R_L = 1.013 \text{ k}\Omega \cong 1 \text{ k}\Omega$$

Next

$$I_2 = -\frac{V_2}{R_L} = h_{21} I_1 + h_{22} V_2 \Rightarrow V_2 (h_{22} + 1/R_L) = -h_{21} I_1$$

Substituting this expression into the second hybrid equation gives:

$$V_1 = h_{11} I_1 + \frac{h_{12} (-h_{21})}{(h_{22} + 1/R_L)} I_1$$

The input resistance is given by

$$R_{in} \approx h_{11} - h_{12} R_L h_{21} \quad (\text{since } h_{22} \ll 1/R_L)$$

Finally

$$R_{in} = 45 - (5 \times 10^{-4})(10^3)(80) = 5 \Omega < 10 \Omega$$

DP 17-4

$$Z_{11} = 2 + \frac{4(12)}{4+12} = 5 \Omega \quad \text{and} \quad Z_{22} = \frac{8(8)}{8+8} = 4 \Omega$$

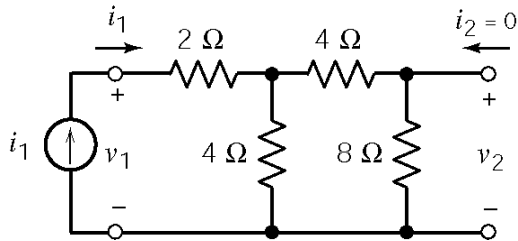

$$V_2 = 8 \left[\frac{4}{4+12} I_1 \right] = 2 I_1 \Rightarrow Z_{21} = \left. \frac{V_2}{I_1} \right|_{I_2=0} = 2 \Omega$$

Similarly $Z_{12} = 2 \Omega$

Thèvenin: $Z_T = Z_{22} = 4 \Omega$ so for maximum power transfer, use $R_L = 4 \Omega$

$$P_{RL} = \frac{\left(\frac{V_s}{2} \right)^2}{4} = 89.3 \text{ W} \Rightarrow V_s = 37.8 \text{ V}$$

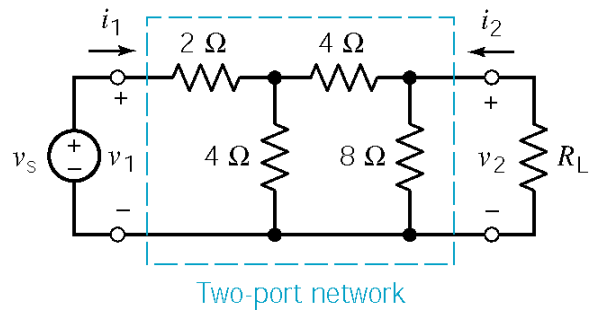

DP 17-5

The circuit consists of 4 cascaded stages. Represent each stage by a transmission matrix using:

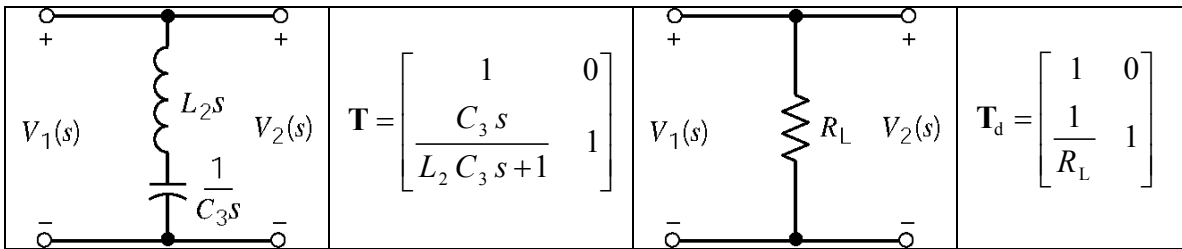
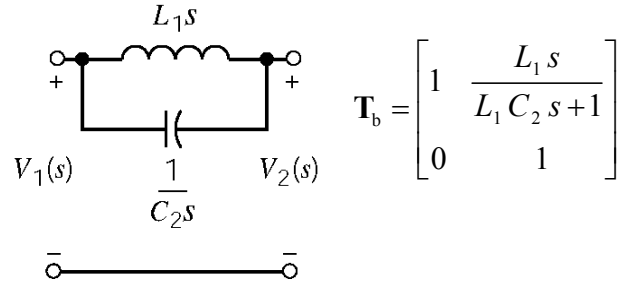
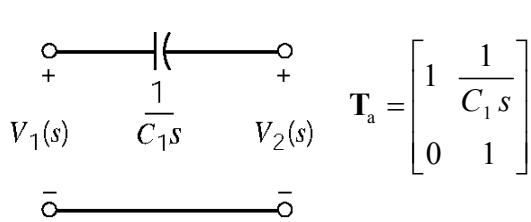
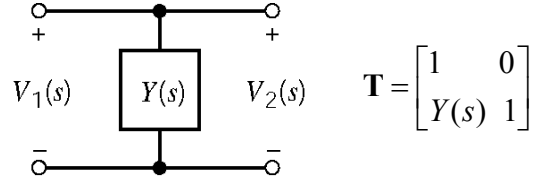
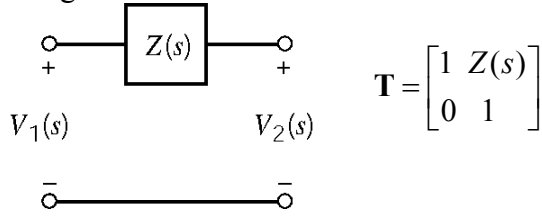

$$\mathbf{T} = \mathbf{T}_a \mathbf{T}_b \mathbf{T}_c \mathbf{T}_d = \begin{bmatrix} 1 + \frac{L_1 C_1 s}{L_1 C_2 C_1 s^2 + C_1 s} \times \frac{C_3 s}{R_L L_2 C_3 s + R_L} & \frac{L_1 C_1 s}{L_1 C_2 C_1 s^2 + C_1 s} \\ \frac{C_3 s}{R_L L_2 C_3 s + R_L} & 1 \end{bmatrix}$$