

**marathon**<sup>®</sup>  
— Motors

Electric Motors  
Gear Reducers  
Gear Motors  
Variable Speed Drives



MARATHON MOTORS BASIC TRAINING MANUAL

Basic training for  
industrial-duty and  
commercial-duty products.

A Regal Brand

**REGAL**

# **Basic Training**

## **Industrial-Duty & Commercial-Duty**

**Electric Motors  
Gearmotors**

**Gear Reducers  
AC & DC Drives**

A Publication Of

**marathon**<sup>TM</sup>  

---

Motors

Copyright ©2013

# Contents

<b>I.</b>	<b>Introduction</b> . . . . .	<b>5</b>
	Electric Motor History and Principles	
<b>II.</b>	<b>General Motor Replacement Guidelines</b> . . . . .	<b>8</b>
<b>III.</b>	<b>Major Motor Types</b> . . . . .	<b>15</b>
	AC Single Phase	
	AC Polyphase	
	Direct Current (DC)	
	Gearmotors	
	Brakemotors	
	Motors For Precise Motor Control	
	Permanent Magnet (PMAC) Motors	
	Benefits of PMAC Motor	
<b>IV.</b>	<b>Mechanical Considerations</b> . . . . .	<b>22</b>
	Enclosures and Environment	
	NEMA Frame/Shaft Sizes	
	NEMA Frame Suffixes	
	Frame Prefixes	
	Mounting	
	Types of Mounts	
	Application Mounting	
	Motor Guidelines for Belted Applications	
<b>V.</b>	<b>Electrical Characteristics and Connections</b> . . . . .	<b>35</b>
	Voltage	
	Phase	
	Current (Amps)	
	Hertz/Frequency	
	Horsepower	
	Speeds	
	Insulation Class	
	Service Factor	
	Capacitors	
	Efficiency	
	Encoders	
	Thermal Protection (Overload)	

- Shaft Grounding Devices
- Faraday Shield
- Grounding Brush
- Shaft Grounding Ring
- Insulated Bearings
- Torque Speed Characteristics
- Individual Branch Circuit Wiring
- Motor Starters
- Across the Line Starting of Induction Motors
- Magnetic Starters
- Reduced Voltage Starters
- Primary Resistance Starters
- Autotransformer Starters
- Wye-Delta Starting
- Part Winding Starters
- Reading a Model Number
- Major Motor Components

- VI. Metric (IEC) Designations .....56**
  - IEC / NEMA Dimensional Comparison
  - IEC Enclosure Protection Indexes
  - IEC Cooling, Insulation and Duty Cycle Indexes
  - IEC Design Types
  - IEC Mounting Designations
  
- VII. Motor Maintenance .....61**
  - Lubrication Procedure
  - DC Motor Trouble-Shooting
  - AC Motor Trouble-Shooting
  - Relubrication Interval Chart
  
- VIII. Common Motor Types and Typical Applications .....69**
  - Alternating Current Designs
  - Elevator Motors
  - Direct Current Designs
  
- IX. Gear Reducers and Gearmotors .....75**
  - Right-Angle Worm Gear Reducers
  - Parallel-Shaft Gear Reducers
  - Gearmotors

Installation and Application Considerations  
Special Environmental Considerations  
Gear Reducer Maintenance

**X. Adjustable Speed Drives .....84**  
DC Drives  
AC Drives  
"One Piece" Motor/Drive Combinations  
AC Drive Application Factors  
Motor Considerations With AC Drives  
Routine Maintenance of Electrical Drives

**XI. Engineering Data .....94**  
Temperature Conversion Table  
Mechanical Characteristics Table  
Electrical Characteristics Table  
Fractional/Decimal/Millimeter Conversion

**XII. Glossary.....97**

# CHAPTER I

## Electric Motor History and Principles

The electric motor in its simplest terms is a converter of electrical energy to useful mechanical energy. The electric motor has played a leading role in the high productivity of modern industry, and it is therefore directly responsible for the high standard of living being enjoyed throughout the industrialized world.

The beginnings of the electric motor are shrouded in mystery, but this much seems clear: The basic principles of electromagnetic induction were discovered in the early 1800's by Oersted, Gauss and Faraday, and this combination of Scandinavian, German and English thought gave us the fundamentals for the electric motor. In the late 1800's the actual invention of the alternating current motor was made by Nikola Tesla, a Serb who had migrated to the United States. One measure of Tesla's genius is that he was granted more than 900 patents in the electrical field. Before Tesla's time, direct current motors had been produced in small quantities, but it was his development of the versatile and rugged alternating current motor that opened a new age of automation and industrial productivity.

An electric motor's principle of operation is based on the fact that a current-carrying conductor, when placed in a magnetic field, will have a force exerted on the conductor proportional to the current flowing in the conductor and to the strength of the magnetic field. In alternating current motors, the windings placed in the laminated stator core produce the magnetic field. The aluminum bars in the laminated rotor core are the current-carrying conductors upon which the force acts. The resultant action is the rotary motion of the rotor and shaft, which can then be coupled to various devices to be driven and produce the output.

Many types of motors are produced today. Undoubtedly, the most common are alternating current induction motors. The term "induction" derives from the transference of power from the stator to the rotor through electromagnetic induction. No slip rings or brushes are required since the load currents in the rotor conductors are induced by transformer action. The induction motor is, in effect, a transformer - with the stator winding being the primary winding and the rotor bars and end rings being the movable secondary members.

Both single-phase and polyphase (three-phase) AC motors are produced by Marathon Motors and many other manufacturers. In polyphase motors, the placement of the phase winding groups in conjunction with the phase sequence of the power supply line produces a rotating field around the rotor surface. The rotor tends to follow this rotating field with a rotational speed that varies inversely with the number of poles wound into the stator. Single-phase motors do not produce a rotating field at a standstill, so a starter winding is added to give the effect of a polyphase rotating field. Once the motor is running, the start winding can be cut out of the circuit, and the motor will continue to run on a rotating field that now exists due to the motion of the rotor interacting with the single-phase stator magnetic field.

The development of power semiconductors and microprocessors has brought efficient adjustable speed control to AC motors through the use of inverter drives. Through this technology, the most recent designs of so-called pulse width modulated AC drives are capable of speed and torque regulation that equals or closely approximates direct current systems.

Marathon Motors also produces permanent-magnet direct current motors. The DC motor is the oldest member of the electric motor family. Technological breakthroughs in magnetic materials, as well as solid state electronic controls and high-power-density rechargeable batteries, have all revitalized the versatile DC motor.

DC motors have extremely high torque capabilities and can be used in conjunction with relatively simple solid state control devices to give programmed acceleration and deceleration over a wide range of selected speeds. Because the speed of a DC motor is not dependent on the number of poles, there is great versatility for any constant or variable speed requirement.

In most common DC motors, the magnetic field is produced by high-strength permanent magnets, which have replaced traditional field coil windings. The magnets require no current from the power supply. This improves motor efficiency and reduces internal heating. In addition, the reduced current draw enhances the life of batteries used as power supplies in mobile or remote applications.

Both AC and DC motors must be manufactured with a great deal of precision in order to operate properly. Marathon Motors and other major

manufacturers use laminated stator, rotor and armature cores to reduce energy losses and heat in the motor. Rotors for AC motors are heat treated to separate the aluminum bars from the rotor's magnetic laminations. Shaft and bearing tolerances must be held to ten thousandths of an inch. The whole structure of the motor must be rigid to reduce vibration and noise. The stator insulation and coil winding must be done in a precise manner to avoid damaging the wire insulation or ground insulation. And mountings must meet exacting dimensions. This is especially true for motors with NEMA C face mountings, which are used for direct coupling to speed reducers, pumps and other devices.

The electric motor is, of course, the very heart of any machine it drives. If the motor does not run, the machine or device will not function. The importance and scope of the electric motor in modern life is attested to by the fact that electric motors, numbering countless millions in total, convert more energy than do all our passenger automobiles. Electric motors are much more efficient in energy conversion than automobiles, but they are such a large factor in the total energy picture that renewed interest is being shown in motor performance. Today's industrial motors have energy conversion efficiency exceeding 96% in larger horsepowers.

This efficiency, combined with unsurpassed durability and reliability, will continue to make electric motors the "prime movers" of choice for decades to come.

# CHAPTER II

## General Motor Replacement Guidelines

Electric motors are the versatile workhorses of industry. In many applications, motors from a number of manufacturers can be used.

Major motor manufacturers today make every effort to maximize interchangeability, mechanically and electrically, so that compromise does not interfere with reliability and safety standards. However, no manufacturer can be responsible for misapplication. If you are not certain of a replacement condition, contact a qualified motor distributor, sales office or service center.

### Safety Precautions

---

- Use safe practices when handling, lifting, installing, operating, and maintaining motors and related equipment.
- Install motors and related equipment in accordance with the National Electrical Code (NEC) local electrical safety codes and practices and, when applicable, the Occupational Safety and Health Act (OSHA).
- Ground motors securely. Make sure that grounding wires and devices are, in fact, properly grounded.

***Failure to ground a motor properly  
may cause serious injury.***

Before servicing or working near motor-driven equipment, disconnect the power source from the motor and accessories.

### Selection

---

Identifying a motor for replacement purposes or specifying a motor for new applications can be done easily if the correct information is known. This includes:

- Mechanical requirements of the driven load
- Physical and environmental considerations

- Efficiency and economic considerations
- Electrical Characteristics and Connections

Much of this information consists of standards defined by the National Electrical Manufacturers Association (NEMA). These standards are widely used throughout North America. In other parts of the world, the standards of the International Electrotechnical Commission (IEC) are most often used.

## **Driven Load - Mechanical requirements**

---

- For a motor to drive a load properly, It must produce enough torque to accelerate from standstill to operating speed, and to supply enough power for all possible demands without exceeding its design limits.
- To specify the motor properly, the following characteristics of the load should be considered:

### **1) Running characteristics:**

- Continuous running, constant load.
  - horsepower requirement
- Continuous running, varying load
  - peak horsepower requirement
- Cyclical load
  - peak torque and horsepower requirements

### **2) Speed**

- Constant speed
- Multi-speed
  - what speeds required?
- Adjustable speed
  - determine needed speed range

### **3) Starting and Stopping**

- Frequency of starting and stopping
- Starting torque requirement
- Acceleration restrictions
- Requirements for braking
  - mechanical
  - plugging

From this information the size and design characteristics of the motor, as well as control and braking requirements can be determined.

# Physical and Environmental Consideration

---

## Usual Service Conditions

Motor ratings apply to motors operating under usual service conditions.

NEMA and EEMAC (Electrical Equipment Manufacturers Association of Canada) standards specify usual environmental conditions as:

1. Exposure to an ambient temperature in the range of 0° to 40°C or when water cooling is used, in the range of 10° to 40°C.
2. Exposure to an altitude which does not exceed 3300 feet (1000 meters) (see MG1-14.04)
3. Installation on a rigid mounting surface
4. Installation in areas or supplementary enclosures which do not seriously interfere with the ventilation of the machine

## Unusual Service Conditions

The manufacturer should be consulted if the motor is to be operated in unusual service conditions.

NEMA and EEMAC standards also specify typical unusual service conditions.

### 1) Exposure to:

- Combustible, explosive, abrasive or conducting dusts
- Lint or very dirty operating conditions where the accumulation of dirt may interfere with normal ventilation
- Chemical fumes, flammable or explosive gases
- Nuclear radiation
- Steam, salt-laden air, or oil vapor
- Damp or very dry locations, radiant heat, vermin infestation, or atmospheres conducive to the growth of fungus
- Abnormal shock, vibration, or mechanical loading from external sources
- Abnormal axial or side thrust imposed on the motor shaft

- 2) Operation where:
  - Excessive departure from rated voltage or frequency exceeding 10%
  - Unbalanced Voltage between legs by more than 1%
- 3) Operation of speeds above the highest rated speed
- 4) Operation in a poorly ventilated room or an inclined position
- 5) Operation subjected to:
  - Torsional impact loads
  - Repetitive abnormal overloads
  - Reversing or electric braking

## **Enclosure**

- The enclosure for the motor should be chosen to protect it from the expected operating environment
- See Chapter IV for Enclosure listings

## **Mounting**

Motors are generally mounted horizontally with feet attached to the floor, but other arrangements are common:

- wall mounted
- ceiling mounted
- pedestal mounted
- face mounted
- flange mounted

The size and length of the shaft can be specified if the standard shaft types or materials are not suitable for the required mounting arrangement or machine configuration

## **Insulation**

- See Chapter V for table of Insulation Class information
- The type of insulation used in a motor depends on the operating temperature that the motor will experience. Motors are specified by ambient temperature and insulation class.
- Class A is an older classification. Class B is the standard for current motor designs and class F and H are used in higher temperature applications.

## Efficiency and Economics

---

When selecting a motor for a particular application, both its capital cost and the cost of energy for operation should be considered.

With today's EISA mandates that went into affect on Dec. 19, 2010, we have little choice in selecting the efficiency of the motor, especially if the motor is a 140 frame motor or higher and rated over 1 HP. There are no EISA mandates today for 1- Phase motors.

## Electrical Supply Distribution System

---

The electrical supply distribution system must supply the correct voltage and have sufficient capacity to start and operate the motor load.

### Voltage and Frequency

- Motors are available in standard voltage ranges:
- Single-phase motors are rated for 120/240 volts @ 60 Hz
- Three-phase motors up to 100 HP are available for 208-230/460 or 575 volts @ 60 Hz.
- 125 HP and up – 460, 575, 2400 or 4160 volts @ 60 Hz
- Other voltages and frequencies can be ordered to meet special requirements
- Single-phase and three-phase motors are designed to operate successfully with voltage variations of +/- 10%.
- Phase unbalance must be less than 1% for proper motor operation. Phase unbalance leads to excessive temperature rise and a rise to the full load amps of the motor.
- Frequency variation of up to 5% is permitted for normal motor operation. Motor speed varies directly with the frequency of the power supply.

# Nameplate

Nameplate data is the critical first step in determining motor replacement. Much of the information needed can generally be obtained from the nameplate. Record all nameplate information; it can save time and confusion.

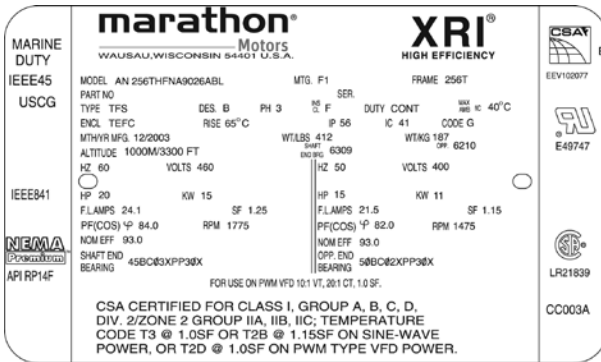

## Important Nameplate Data

- **MODEL** - The ID number
- **DATE CODE** - The month and year manufactured
- **MTG.** - Mounting
- **FRAME** - The size & mounting
- **PART NO.** - Customer part number
- **SER.** - Serial number
- **TYPE** - Electrical type
- **DES.** - Code by NEMA or IEC
- **PH** - Electrical phase usually 1 or 3
- **INS CL** - Insulation Class
- **DUTY** - Time rating under load
- **MAX AMB** - The allowable surrounding air temperature
- **ENCL** - Enclosure (i.e. TEFC)

- **RISE** - The temperature rise over ambient expressed in degrees Celsius when the motor operates at nameplated HP or KW
- **IP** - Inherent Protection of the enclosure to solids and liquids as defined by IEC 34-5
- **IC** - Inherent Cooling
- **CODE** - NEMA locked-rotor KVA
- **MTH/YR MFG.** - Month and year motor was manufactured
- **WT/LBS** - Motor weight in pounds
- **WT/KG** - Motor weight in kilograms
- **HZ** - Input frequency of the power supply, usually 50 or 60 HZ
- **VOLTS** - Voltage rating of the motor at the operating frequency
- **HP** - Rated horsepower the motor will produce
- **KW** - Rated output in watts
- **F.L. AMPS** - The rated load current expressed in amps at nameplated horsepower with nameplate voltage and frequency
- **S.F.** - Percentage of the rated horsepower the motor can safely operate at: Example: 1.15 SF (115% of rated HP)
- **PF / COS** - Power Factor / Cosine is the ratio of actual power to the apparent power
- **RPM** - Full load speed at rated frequency
- **NOM EFF** - Average Efficiency
- **SHAFT END BEARING** - Manufacturer drive end bearing number
- **OPP. END BEARING** - Manufacturer opposite drive end bearing number
- **SHAFT END BRG** - Drive end bearing size
- **OPP** - Opposite drive end bearing size

# CHAPTER III

## Major Motor Types

Alternating current (AC) induction motors are divided into two electrical categories based on their power source – single phase and polyphase (three phase).

### AC Single Phase Types

---

Types of single-phase motors are distinguished mostly by the way they are started and the torque they develop.

**Shaded Pole** motors have low starting torque, low cost, low efficiency, and no capacitors. There is no start switch. These motors are used on small direct drive fans and blowers found in homes. Shaded pole motors should not be used to replace other types of single-phase motors.

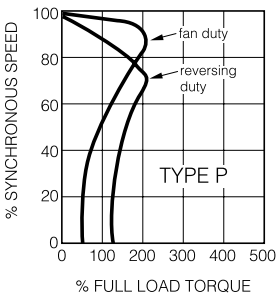

### PSC (Permanent Split Capacitor)

motors have applications similar to shaded pole, except much higher efficiency, lower current (50% - 60% less), and higher horsepower capability. PSC motors have a run capacitor in the circuit at all times. They can be used to replace shaded pole motors for more efficient operation and can be used for fan-on-shaft fan applications, but not for belted fans due to the low starting torque.

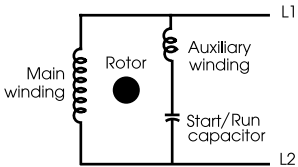

PSC circuit diagram

**Split Phase** motors have moderate to low starting torque (100% - 125% of full load), high starting current, no capacitor, and a start switch to drop out the start winding when the motor reaches approximately 75% of its operating speed. They are used on easy-to-start belt drive fans and blowers, as well as light-start pump applications.

**Capacitor Start** motors are designed in both moderate and high starting torque types with both having moderate starting current, high breakdown torques.

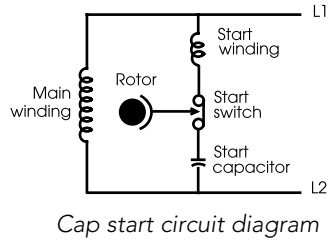
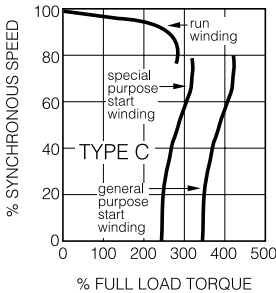

Moderate-torque motors are used on applications in which starting requires torques of 175% or less or on light loads such as fans, blowers, and light-start pumps. High-torque motors have starting torques in excess of 300% of full load and are used on compressors, industrial, commercial and farm equipment. Capacitor start motors use a start capacitor and a start switch, which takes the capacitor and start winding out of the circuit when motor reaches approximately 75% of its operating speed.

**Capacitor Start/Capacitor Run** motors have applications and performance similar to capacitor start except for the addition of a run capacitor (which stays in circuit) for higher efficiency and reduced running amperage. Generally, start/ capacitor run motors are used for 3 HP and larger single-phase applications.



*On industrial duty motors, capacitors are usually protected by metal cases attached to the motor frame. This capacitor start/capacitor run motor has two cases.*



*A heavy-duty polyphase motor with cast-iron frame.*

## AC Polyphase (Three-Phase)

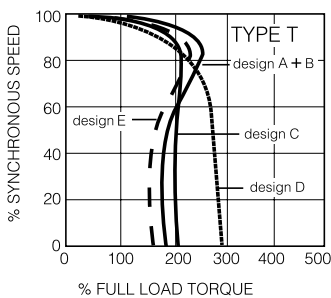

**Polyphase** induction motors have a high starting torque, power factor, high efficiency, and low current. They do not use a switch, capacitor, relays, etc., and are suitable for larger commercial and industrial applications.

Polyphase induction motors are specified by their electrical design type: A, B, C, D or E, as defined by the National Electrical Manufacturers Association (NEMA). These designs are suited to

particular classes of applications based upon the load requirements typical of each class.

The table on the next page can be used to help guide which design type to select based on application requirements.

Because of their widespread use throughout industry and because their characteristics lend themselves to high efficiencies, many types of general-purpose three-phase motors are required to meet mandated efficiency levels under the U.S. Energy Policy Act. Included in the mandates are NEMA Design B, T frame, foot-mounted motors from 1-200 HP.

The following table can be used to help guide which design type should be selected:

## NEMA Electrical Design Standards

Polyphase Characteristics	Locked Rotor Torque (Percent Rated Load Torque)	Pull-Up Torque (Percent Rated Load Torque)	Break-down Torque (Percent Rated Load Torque)	Locked Rotor Current (Percent Rated Load Current)	Slip	Typical Applications	Relative Efficiency
Design A High locked rotor torque and high locked rotor current	70-275	65-190	175-300	Not defined	0.5-5%	Fans, blowers, centrifugal pumps and compressors, motor-generator sets, etc., where starting torque requirements are relatively low	Medium or high
Design B Normal locked rotor torque and normal locked rotor current	70-275	65-190	175-300	600-700	0.5-5%	Fans, blowers, centrifugal pumps and compressors, motor-generator sets, etc., where starting torque requirements are relatively low	Medium or high
Design C High locked rotor torque and normal locked rotor current	200-285	140-195	190-225	600-700	1-5%	Conveyors, crushers, stirring motors, agitators, reciprocating pump and compressors, etc., where starting under load is required	Medium
Design D High locked rotor torque and high slip	275	NA	275	600-700	5-8%	High peak loads with or without flywheels such as punch presses, shears, elevators, extractors, winches, hoists, oil-well pumping and wire-drawing motors	Low
Design E Normal locked rotor torque and current, low slip	75-190	60-140	160-200	800-1000	0.5-3%	Fans, blowers, centrifugal pumps and compressors, motor-generator sets, etc., where starting torque requirements are relatively low	High

## Direct Current (DC)

---

Another commonly used motor in industrial applications is the direct current motor. It is often used in applications where adjustable speed control is required.

Permanent magnet DC designs are generally used for motors that produce less than 5 HP. Larger horsepower applications use shunt-wound direct current motors.

*DC motors can be operated from rectified alternating current or from low-voltage battery or generator source. This is a low-voltage design, which includes external connection lugs for the input power. With the rear endshield removed, as in this view, the brush assemblies and commutator that form a DC motor's electrical heart are clearly visible.*

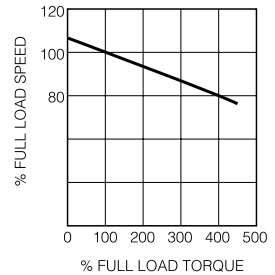
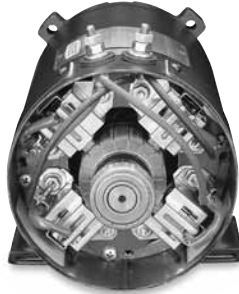

Both designs have linear speedtorque characteristics over the entire speed range. SCR rated motors – those designed for use with common solid-state speed controls – feature high starting torque for heavy load applications and reversing capabilities, and complementary active material to compensate for the additional heating caused by the rectified AC input. Designs are also available for use on generated low-voltage DC power or remote applications requiring battery power.

## Gearmotors

---

A gearmotor is made up of an electric motor, either DC or AC, combined with a geared speed reducer. Spur, helical or worm gears may be used in single or multiple stages. The configuration may be either that of a parallel shaft, emerging from the front of the motor, or a right-angle shaft. Gearmotors are often rated in input horsepower; however, output torque, commonly measured in inch-pounds, and output speed are the critical values.



*Speed reduction gearing is visible in this cutaway view of a parallel-shaft gearmotor. Shown is a small, sub-fractional horsepower gearmotor.*

Gearmotors may be either integral, meaning the gear reducer and motor share a common shaft, or they may be created from a separate gear reducer and motor, coupled together. Integral gearmotors are common in sub-fractional horsepower sizes; separate reducers and motors are more often the case in fractional and integral horsepower. For more on gear reducers and gearmotors, see Chapter IX.

## Brakemotors

---

A brakemotor is a pre-connected package of industrial-duty motor and fail-safe, stop-and-hold spring-set brake. In case of power failure, the brake sets, holding the load in position. Brakemotors are commonly used on hoists or other lifting devices. Brake features can also be added to standard motors through conversion kits that attach to the shaft end of either fan-cooled or open motor.



*A three-phase brakemotor. Note the brake on the fan end. Like many brakemotors, this model has a NEMA C face for direct mounting to the equipment to be driven.*

## Motors for Precise Motion Control

---

These motors are always part of integrated motor-and-controller systems that provide extreme accuracy in positioning and speed. Common applications include computer-controlled manufacturing machines and process equipment. Servomotors are the largest category of motors for precision motion control. AC, DC brush-type, and brushless DC versions are available. Closed-loop control systems, common with servomotors, use feedback devices to provide information to a digital controller, which in turn drives the motor. In some cases, a tachometer may be used for velocity control and an encoder for position information. In other cases, a resolver provides both position and velocity feedback.

Step (or stepper) motors, which move in fixed increments instead of rotating continuously, provide another means of precision motion control. Usually, they are part of open-loop control systems, meaning there are no feedback devices.

## **Permanent Magnet (PMAC) Motors**

---

The PMAC (Permanent Magnet AC) motor is traditionally of a more complex construction than the standard induction motor. With the new motor type, the design has been simplified by using powerful permanent magnets to create a constant flux in the air gap, thereby eliminating the need for the rotor windings and brushes normally used for excitation in synchronous motors. This results in the accurate performance of a synchronous motor, combined with the robust design of a standard induction motor. The motor is energized directly on the stator by the variable speed drive.

### **Benefits of a PMAC Motor**

---

Standard induction motors are not particularly well suited for low-speed operation as their efficiency drops with the reduction in speed. They may also be unable to deliver sufficiently smooth torque across the lower speed range. This is normally overcome by using a gearbox. The new solution provides a high torque drive coupled directly to the load. By eliminating the gearbox, the user saves space and installation costs, as he only needs to prepare the foundations for one piece of machinery. This also gives more freedom in the layout design.

The PMAC motor can deliver more power from a smaller unit. For instance, powering the in-drives of a paper machine directly at 220 to 600 r/min with a conventional induction motor would require a motor frame substantially larger than that of a 1500 r/min motor. Using permanent magnet motors also means higher overall efficiency and less maintenance.

# CHAPTER IV

## Mechanical Considerations

### Enclosures and Environment

---



**Open Drip Proof (ODP)** motors have venting in the end frame and/or main frame, situated to prevent drops of liquid from falling into the motor within a 15° angle from vertical. These motors are designed for use in areas that are reasonably dry, clean, well-ventilated, and usually indoors. If installed outdoors, ODP motors should be protected with a cover that does not restrict air flow.

**Totally Enclosed Non-Ventilated (TENV)** motors have no vent openings. They are tightly enclosed to prevent the free exchange of air, but are not air tight. TENV motors have no cooling fan and rely on convection for cooling. They are suitable for use where exposed to dirt or dampness, but not for hazardous locations or applications having frequent hosedowns.



**Totally Enclosed Fan Cooled (TEFC)** motors are the same as TENV except they have an external fan as an integral part of the motor to provide cooling by blowing air over the outside frame.

**Totally Enclosed Air Over** motors are specifically designed to be used within the air-flow of the fan or blower they are driving. This provides an important part of the motor's cooling.

**Totally Enclosed Hostile and Severe Environment** motors are designed for use in extremely moist or chemical environments, but not for hazardous locations.



**Explosion Proof** motors meet Underwriters Laboratories or CSA standards for use in the hazardous (explosive) locations shown by the UL/CSA label on the motor. The motor user must specify the explosion proof motor required. Locations are considered hazardous because the atmosphere contains or may contain gas, vapor, or dust in explosive quantities.

The National Electrical Code (NEC) divides these locations into classes and groups according to the type of explosive agent. The following list has some of the agents in each classification. For a complete list, see Article 500 of the National Electrical Code.

### ***Class I (Gases, Vapors)***

Group A	Acetylene
Group B	Butadiene, ethylene oxide, hydrogen, propylene oxide
Group C	Acetaldehyde, cyclopropane, diethlether, ethylene, isoprene
Group D	Acetone, acrylonitrile, ammonia, benzene, butane, ethylene dichloride, gasoline, hexane, methane, methanol, naphtha, propane, propylene, styrene, toluene, vinyl acetate, vinyl chloride, xylene

### ***Class II (Combustible Dusts)***

Group E	Aluminum, magnesium and other metal dusts with similar characteristics
Group F	Carbon black, coke or coal dust
Group G	Flour, starch or grain dust

The motor ambient temperature is not to exceed +40°C or -25°C unless the motor nameplate specifically permits another value. Marathon Motors explosion proof motors are approved for all classes noted except Class I, Groups A & B .

## Hazardous Duty Motor Area Classification Chart

Class I Area Classification (Flammable Gases, Vapors or Mists)				Class II Area Classification (Combustible Dusts)			
North America		Europe - ATEX (Category G - Gases)		North America		Europe - ATEX (Category D - Dusts)	
Division 1 Explosion Proof	Division 2 TEFC & TENV	Zone 1 Flameproof	Zone 2 Non-Sparking	Division 1 Explosion Proof	Division 2	Zone 21 Flameproof	Zone 22 Non-Sparking
Group A <sup>①</sup>	Group A	Group IIC, Category G	Group IIC, Category G	-	-	-	-
Group B <sup>②</sup>	Group B	Group IIC, Category G	Group IIC, Category G	-	-	-	-
Group C	Group C	Group IIB, Category G	Group IIB, Category G	-	-	-	-
Group D	Group D	Group IIA, Category G	Group IIA, Category G	-	-	-	-
-	-	-	-	Group E	-	Category D	Category D
-	-	-	-	Group F	Group F <sup>①</sup>	Category D	Category D
-	-	-	-	Group G	Group G <sup>①</sup>	Category D	Category D

- Group is not applicable to that Division or Zone, or is not defined.

<sup>①</sup> Group is not available from Marathon Motors.

<sup>②</sup> Contact factory representative for availability.

## Hazardous Duty Motor Temperature Code Chart

TEMPERATURE CODES		Division 1 Explosion Proof/Zone 1 Flameproof		Division 2/Zone 2 Non-Sparking	
		Class I Area Classification (Flammable Gases, Vapors or Mists)	Class II Area Classification* (Combustible Dusts)	Class I Area Classification (Flammable Gases, Vapors or Mists)	Class II Area Classification (Combustible Dusts)
Temp.	UL/CSA	ATEX	Division 1/Zone 1	Division 1/Zone 21	Division 2/Zone 2
280°C	T2A	T2(280)	Explosion Proof - Class I, Group D (Group C as noted)		
260°C	T2B	T2(260)			XRI <sup>®</sup> Severe Duty & IEEE-841 @ 1.15 S.F., Class I, Groups A,B,C,D (Sine wave power)
215°C	T2D	T2(215)			Available through Marathon's Mod Central on Totally Enclosed EPAct, XRI <sup>®</sup> , XRI <sup>®</sup> Severe Duty or IEEE-841 @ 1.0 S.F. on PWM VFD, Class I, Groups A, B, C, D
200°C	T3	T3			Available through Marathon's Mod Central on Totally Enclosed EPAct, XRI <sup>®</sup> , XRI <sup>®</sup> Severe Duty or IEEE-841 @ 1.0 S.F., Sine wave power Class I, Groups A, B, C, D
165°C	T3B	T3(165)	Explosion Proof - Class I, Group D (Group C as noted), Sine wave or PWM power	Explosion Proof - Class II, Groups F & G, Sine wave or PWM power	
160°C	T3C	T3(160)	Available through Marathon's Mod Central on Explosion Proof - Class I, Group C & D @ 1.0 S.F. - Contact Factory	Available through Marathon's Mod Central on Explosion Proof - Class II, Group F & G @ 1.0 S.F. - Contact Factory	
135°C	T4	T4	ATEX compliant motors	ATEX compliant motors	

\* Class II, Division 2 motors are not available from Marathon Motors, Zone 22 groups are not defined by ATEX.

# NEMA Frame/Shaft Sizes

Frame numbers are not intended to indicate electrical characteristics such as horsepower. However, as a frame number becomes higher so in general does the physical size of the motor and the horsepower. There are many motors of the same horsepower built in different frames. NEMA (National Electrical Manufacturers Association) frame size refers to mounting only and has no direct bearing on the motor body diameter.

In any standard frame number designation there are either two or three numbers. Typical examples are frame numbers 48, 56, 145, and 215. The frame number relates to the "D" dimension (distance from center of shaft to center bottom of mount). For example, in the two-digit 56 frame, the "D" dimension is  $3\frac{1}{2}$ ", 56 divided by 16 =  $3\frac{1}{2}$ ". For the "D" dimension of a three-digit frame number, consider only the first two digits and use the divisor 4. In frame number 145, for example, the first two digits divided by the constant 4 is equal to the "D" dimension.  $14$  divided by  $4 = 3\frac{1}{2}$ ". Similarly, the "D" dimension of a 213 frame motor is  $5\frac{1}{4}$ ", 21 divided by  $4 = 5\frac{1}{4}$ ".

By NEMA definition, two-digit frame numbers are fractional frames even though 1 HP or larger motors may be built in them. Three-digit frame numbers are by definition integral frames. The third numeral indicates the distance between the mounting holes parallel to the base. It has no significance in a footless motor.

A summary of NEMA standard dimensions is on the facing page.

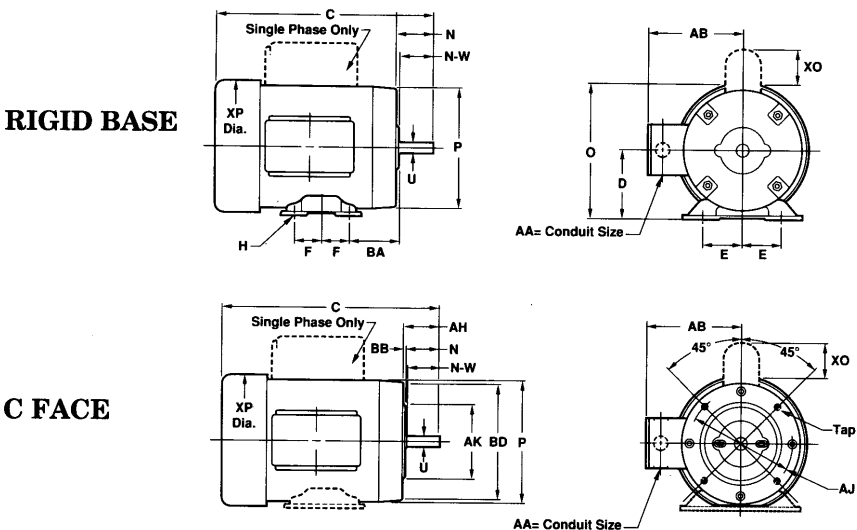

# Motor Frame Dimensions (inches)

NEMA Frame Size S	D	E	F	H	N	O	P	U	N-W	AA	AB	AH	AJ	AK	BA	BB	BD	XO	XP	TAP	KEY
42	2.58	1.34	27/32	9/32 Slot	1 1/4	5 1/16	4 7/8	3/8	1 1/8	3/8	4 1/2	1 5/16	3 3/4	3	2 1/16	1/8	4 7/8	1 5/8	5 1/8	1/4-20	3/64 Flat
48	3	2 1/8	1 3/8	11/32 Slot	1 9/16	5 13/16	5 19/32	1/2	1 1/2	1/2	4 7/8	1 11/16	3 3/4	3	2 1/2	1/8	5	2 1/4	5 7/8	1/4-20	3/64 Flat
S56	3 1/2	2 7/16	1 1/2	11/32 Slot	1 15/16	6 5/16	5 19/32	5/8	1 7/8	1/2	4 7/8	2 1/16	5 7/8	4 1/2	2 3/4	1/8	6 1/2	2 1/4	5 7/8	3/8-16	3/16
56	3 1/2	2 7/16	1 1/2	11/32 Slot	1 15/16	6 13/16	6 19/32	5/8	1 7/8	1/2	5 5/16	2 1/16	5 7/8	4 1/2	2 3/4	1/8	6 1/2	2 1/4	7 5/32	3/8-16	3/16
143T	3 1/2	2 3/4	2	11/32	2 3/8	6 13/16	6 19/32	7/8	2 1/4	3/4	5 5/16	2 1/8	5 7/8	4 1/2	*2 1/4	1/8	6 1/2	2 1/4	7 5/32	3/8-16	3/16
145T	3 1/2	2 3/4	2 1/2	11/32	2 3/8	6 13/16	6 19/32	7/8	2 1/4	3/4	5 5/16	2 1/8	5 7/8	4 1/2	*2 1/4	1/8	6 1/2	2 1/4	7 5/32	3/8-16	3/16
182T	4 1/2	3 3/4	2 1/4	13/32	2 7/8	8 3/4	8 15/32	1 1/8	2 3/4	3/4	6 3/8	2 5/8	7 1/4	8 1/2	*2 3/4	1/4	8 7/8	2 1/4	9 3/32	1/2-13	5/16
184T	4 1/2	3 3/4	2 3/4	13/32	2 7/8	8 3/4	8 15/32	1 1/8	2 3/4	3/4	6 3/8	2 5/8	7 1/4	8 1/2	*2 3/4	1/4	8 7/8	2 1/4	9 3/32	1/2-13	5/16
S213T	5 1/4	4 1/4	2 3/4	13/32	3 1/2	9 15/16	8 15/32	1 3/8	3 3/8	1	8 5/16	3 1/8	7 1/4	8 1/2	*3 1/2	1/4	9	2 1/4	9 3/32	1/2-13	5/16
213T	5 1/4	4 1/4	2 3/4	13/32	—	10 11/16	10 13/16	1 3/8	3 3/8	1	8 5/16	3 1/8	7 1/4	8 1/2	*3 1/2	1/4	9	2 1/4	11 3/32	1/2-13	5/16
215T	5 1/4	4 1/4	3 1/2	13/32	—	10 11/16	10 13/16	1 3/8	3 3/8	1	8 5/16	3 1/8	7 1/4	8 1/2	*3 1/2	1/4	9	2 1/4	11 3/32	1/2-13	5/16
254T	6 1/4	5	4 1/8	17/32	—	12 15/16	13 1/4	1 5/8	4	1 1/4	11 5/8	3 3/4	7 1/4	8 1/2	*4 1/4	1/4	9 5/8	—	12 7/8	1/2-13	3/8
261T	6 1/4	5	5	17/32	—	12 15/16	13 1/4	1 5/8	4	1 1/4	11 5/8	3 3/4	7 1/4	8 1/2	*4 1/4	1/4	9 5/8	—	12 7/8	1/2-13	3/8
284TS	7	4 3/4	4 3/4	17/32	—	14 1/2	14 3/4	1 7/8	3 1/4	1 1/2	11 3/4	4 3/8	9	10 1/2	4 3/4	1/4	11	—	14 1/2	1/2-13	3/2
284T	7	5 1/2	4 3/4	17/32	—	14 1/2	14 3/4	1 7/8	3 1/4	1 1/2	11 3/4	4 3/8	9	10 1/2	4 3/4	1/4	11	—	14 1/2	1/2-13	3/2
286TS	7	5 1/2	5 1/2	17/32	—	14 1/2	14 3/4	1 7/8	3 1/4	1 1/2	11 3/4	4 3/8	9	10 1/2	4 3/4	1/4	11	—	14 1/2	1/2-13	3/2
286T	7	5 1/2	5 1/2	17/32	—	14 1/2	14 3/4	1 7/8	3 1/4	1 1/2	11 3/4	4 3/8	9	10 1/2	4 3/4	1/4	11	—	14 1/2	1/2-13	3/2
324TS	8	5 1/4	5 1/4	21/32	—	15 3/4	15 3/4	1 7/8	3 3/4	2	13 1/2	5	11	12 1/2	5 1/4	1/4	13 3/8	—	15 3/4	5/8 11	1/2
324T	8	6 1/4	5 1/4	21/32	—	15 3/4	15 3/4	1 7/8	3 3/4	2	13 1/2	5	11	12 1/2	5 1/4	1/4	13 3/8	—	15 3/4	5/8 11	1/2
326TS	8	6 1/4	6	21/32	—	15 3/4	15 3/4	1 7/8	3 3/4	2	13 1/2	5	11	12 1/2	5 1/4	1/4	13 3/8	—	15 3/4	5/8 11	1/2
326T	8	6 1/4	6	21/32	—	15 3/4	15 3/4	1 7/8	3 3/4	2	13 1/2	5	11	12 1/2	5 1/4	1/4	13 3/8	—	15 3/4	5/8 11	1/2
364TS	9	5 5/8	5 5/8	21/32	—	17 13/16	17 3/8	1 7/8	3 3/4	3	15 7/16	5 5/8	11	12 1/2	5 7/8	1/4	14	—	17 3/4	5/8 11	1/2
364T	9	7	5 5/8	21/32	—	17 13/16	17 3/8	1 7/8	3 3/4	3	15 7/16	5 5/8	11	12 1/2	5 7/8	1/4	14	—	17 3/4	5/8 11	1/2
365TS	9	7	6 1/8	21/32	—	17 13/16	17 3/8	1 7/8	3 3/4	3	15 7/16	5 5/8	11	12 1/2	5 7/8	1/4	14	—	17 3/4	5/8 11	1/2
365T	9	7	6 1/8	21/32	—	17 13/16	17 3/8	1 7/8	3 3/4	3	15 7/16	5 5/8	11	12 1/2	5 7/8	1/4	14	—	17 3/4	5/8 11	1/2
404TS	10	6 1/8	6 1/8	13/16	—	19 5/16	19 1/8	2 1/8	4 1/4	3	16 5/16	7	11	12 1/2	6 5/8	1/4	15 1/2	—	19 3/8	5/8 11	1/2
404T	10	8	6 1/8	13/16	—	19 5/16	19 1/8	2 1/8	4 1/4	3	16 5/16	7	11	12 1/2	6 5/8	1/4	15 1/2	—	19 3/8	5/8 11	1/2
405TS	10	8	6 7/8	13/16	—	19 5/16	19 1/8	2 1/8	4 1/4	3	16 5/16	7	11	12 1/2	6 5/8	1/4	15 1/2	—	19 3/8	5/8 11	1/2
405T	10	8	6 7/8	13/16	—	19 5/16	19 1/8	2 1/8	4 1/4	3	16 5/16	7	11	12 1/2	6 5/8	1/4	15 1/2	—	19 3/8	5/8 11	1/2
444TS	11	7 1/4	7 1/4	13/16	—	22 1/4	22	2 3/8	4 3/4	3	21 11/16	8 1/4	14	16	7 1/2	1/4	18	—	19 3/8	5/8 11	3/8
444T	11	9	7 1/4	13/16	—	22 1/4	22	2 3/8	4 3/4	3	21 11/16	8 1/4	14	16	7 1/2	1/4	18	—	19 3/8	5/8 11	3/8
445T	11	9	8 1/4	13/16	—	22 1/4	22	3 3/8	8 1/2	3	21 11/16	8 1/4	14	16	7 1/2	1/4	18	—	19 3/8	5/8 11	3/8
447TZ	11	9	10	13/16	—	22 1/4	22	3 3/8	8 1/2	3	21 11/16	8 1/4	14	16	7 1/2	1/4	18	—	19 3/8	5/8 11	3/8

Shaded area denotes dimensions established by NEMA standard MG-1. Other dimensions will vary among manufactures.

## NEMA Frame Suffixes

---

- C = NEMA C face mounting (specify with or without rigid base)
- D = NEMA D flange mounting (specify with or without rigid base)
- H = Indicates a frame with a rigid base having an F dimension larger than that of the same frame without the suffix H. For example, combination 56H base motors have mounting holes for NEMA 56 and NEMA 143-5T and a standard NEMA 56 shaft
- J = NEMA C face, threaded shaft pump motor
- JM = Close-coupled pump motor with specific dimensions and bearings
- JP = Close-coupled pump motor with specific dimensions and bearings
- M = 6 $\frac{3}{4}$ " flange (oil burner)
- N = 7 $\frac{1}{4}$ " flange (oil burner)
- T,TS = Integral horsepower NEMA standard shaft dimensions if no additional letters follow the "T" or "TS".
- TS = Motor with NEMA standard "short shaft" for belt-driven loads.
- Y = Non-NEMA standard mount; a drawing is required to be sure of dimensions. Can indicate a special base, face or flange.
- Z = Non-NEMA standard shaft; a drawing is required to be sure of dimensions.

## Frame Prefixes

---

Letters or numbers appearing in front of the NEMA frame number are those of the manufacturer. They have no NEMA frame significance. The significance from one manufacturer to another will vary.

## Mounting

---

Unless specified otherwise, motors can be mounted in any position or any angle. However, unless a drip cover is used for shaft-up or shaft-down applications, drip proof motors must be mounted in the horizontal or sidewall position to meet the enclosure definition. Mount motor securely to the mounting base of equipment or to a rigid, flat surface, preferably metallic.

## Types of Mounts

---



**Rigid base** is bolted, welded, or cast on main frame and allows motor to be rigidly mounted on equipment.



**Resilient base** has isolation or resilient rings between motor mounting hubs and base to absorb vibrations and noise. A conductor is imbedded in the ring to complete the circuit for grounding purposes.



**NEMA C face mount** is a machined face with a pilot on the shaft end which allows direct mounting with the pump or other direct coupled equipment. Bolts pass through mounted part to threaded hole in the motor face.



**NEMA D flange mount** is a machined flange with rabbet for mountings. Bolts pass through motor flange to a threaded hole in the mounted part. NEMA C face motors are by far the most popular and most readily available. NEMA D flange kits are stocked by some manufacturers, including Marathon Motors.



**Type M or N mount** has special flange for direct attachment to fuel atomizing pump on an oil burner. In recent years, this type of mounting has become widely used on auger drives in poultry feeders.



**Extended through-bolt** motors have bolts protruding from the front or rear of the motor by which it is mounted. This is usually used on small direct drive fans or blowers.

## Application Mounting

---

For direct-coupled applications, align shaft and coupling carefully, using shims as required under motor base. Use a flexible coupling, if possible, but not as a substitute for good alignment practices.

Pulleys, sheaves, sprockets and gears should be generally mounted as close as possible to the bearing on the motor shaft, thereby lessening the bearing load.

The center point of the belt, or system of V-belts, should not be beyond the end of the motor shaft.

The inner edge of the sheave or pulley rim should not be closer to the bearing than the shoulder on the shaft, but should be as close to this point as possible.

The outer edge of a chain sprocket or gear should not extend beyond the end of the motor shaft.

To obtain the minimum pitch diameters for the flat-belt, timing-belt, chain and gear drives, the multiplier given in the following table should be applied to the narrow V-belt sheave pitch diameters in NEMA MG 1-14.444 for alternating current, general-purpose motors, or to the V-belt sheave pitch diameters as determined from NEMA MG 1-14.67 for industrial direct current motors.

Drive	Multiplier
Flat belt*	1.33
Timing belt†	0.9
Chain sprocket	0.7
Spur Gear	0.75
Helical gear	0.85

\* This multiplier is intended for use with conventional single-ply flat belts. When other than single-ply belts are used, the use of a larger multiplier is recommended.

† It is often necessary to install timing belts with a snug fit. However, tension should be no more than what is necessary to avoid belt slap or tooth jumping.

# Motor Guidelines for Belted Applications

---

*The information contained in this document is intended to be used for applications where Marathon Motors motors are connected to other equipment through the use of a V-belt drive. These are to be used as guidelines only since Marathon Motors does not warrant the complete drive system.*

The goal of any belted system is to efficiently transmit the required torque while minimizing the loads on the bearings and shafts of the motor and driven equipment. This can be accomplished by following these four basic guidelines:

1. Use the largest practical sheave diameter.
2. Use the fewest number of belts possible.
3. Keep sheaves as close as possible to support bearings.
4. Tension the belts to the lowest tension that will still transmit the required torque without slipping.

## 1. Sheave Diameter Guidelines

In general, smaller sheaves produce greater shaft stress and shaft deflection due to increased belt tension. See Table 1 for minimum recommended sheave diameters. Using larger sheaves increases the contact with belts which reduces the number of belts required. It also increases the belt speed, resulting in higher system efficiencies. When selecting sheaves, do not exceed the manufacturer's recommended maximum rim speed. Typically 6,500 feet per minute for cast iron sheaves, 8,000 feet per minute for ductile iron and 10,000 feet per minute for steel. The following formula will determine sheave rim speed:

$$\frac{\text{Shaft RPM} \times 3.14 \times \text{Sheave Dia. in inches}}{12}$$

## 2. Number of Belts

In general, use the fewest number of belts that will transmit the required torque without slipping. See Table 1 for maximum recommended number of belts. Each belt adds to the tension in the system which increases load on the shafts and bearings. Belts are most efficient when operated at or near their rated horsepower.

If the sheaves have more grooves than the number of belts required, use the grooves closest to the motor.

### 3. Sheave Location

Install sheaves as close to the housings as possible to increase the bearing life of the motor and driven equipment.

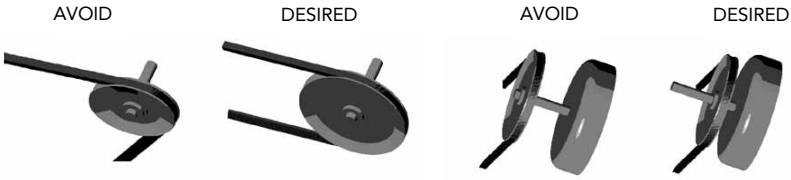

### 4. Belt Tension

In general, belt tensions are to be kept as loose as possible while still transmitting the required torque without slipping. Belt tensions must be measured with a belt tension gage. These inexpensive gages may be obtained through belt manufacturers, or distributors.

Proper belt tension is determined by measuring the required force to deflect the center of the belt at a given distance. See Fig. 3. The proper deflection (in inches) is determined by dividing the belt span in inches by 64. Calculate the proper deflection and then see Table 1 for the required belt deflected force to achieve the calculated deflection.

After tensioning the belt, rotate the sheaves for several rotations or start the system and run for a few minutes if possible to seat belts into the grooves, then re-tension the belts.

Belt tensioning by feel is **NOT** acceptable. Tensioning by “feel” can be very misleading, and can damage equipment. New belts will stretch during use, and should be retensioned after the first eight hours of use.

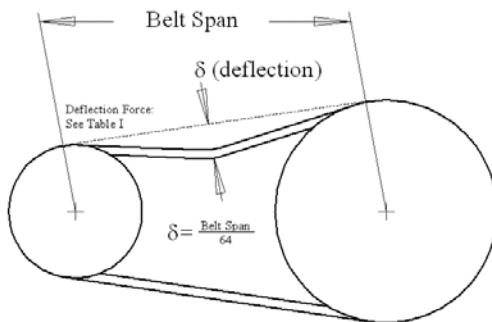

**Table 1: Recommended Sheave Diameters, Belt Type and Number of Belts**

Motor Hp	1200 rpm			1800 rpm			3600 rpm					
	Min. Sheave Dia. (in.)	Belt Type	Max. # of Belts	Belt Deflected Force (lbs.)	Min. Sheave Dia. (in.)	Belt Type	Max. # of Belts	Belt Deflected Force (lbs.)	Min. Sheave Dia. (in.)	Belt Type	Max. # of Belts	Belt Deflected Force (lbs.)
0.75	2.2	3VX	1	3.4	2.2	3VX	1	2.2	2.2	3VX	1	1.3
1	2.4	3VX	1	4.0	2.2	3VX	1	3.1	2.2	3VX	1	1.6
1.5	2.4	3VX	2	3.1	2.4	3VX	2	2.1	2.2	3VX	1	2.5
2	2.4	3VX	3	2.8	2.4	3VX	2	2.9	2.4	3VX	1	2.7
3	3.0	3VX	2	2.9	2.4	3VX	3	2.9	2.4	3VX	2	2.3
5	3.0	3VX	3	4.0	3.0	3VX	3	3.7	2.4	3VX	3	2.5
7.5	3.8	3VX	4	4.7	3.0	3VX	4	4.1	3.0	3VX	2	4.2
10	4.4	3VX	4	5.4	3.8	3VX	4	4.3	3.0	3VX	3	3.8
15	4.4	3VX	5	5.4	4.4	3VX	4	5.4	3.8	3VX	3	4.4
20	5.2	3VX	6	6.0	4.4	3VX	6	4.8	4.4	3VX	3	5.0
25	6.0	3VX	7	5.6	4.4	3VX	7	5.2	4.4	3VX	4	4.7
30	6.8	3VX	7	6.0	5.2	3VX	7	5.3				
40	6.8	5VX	4	12	6.0	3VX	7	6.0				
50	8.2	5VX	4	14.5	6.8	3VX	8	6.0				
60	8.2	5VX	5	14	7.4	5VX	4	13.5				
75	10.0	5VX	5	14.5	8.6	5VX	4	14.5				
100	10.0	5VX	6	16	8.6	5VX	6	13				
125	12.0	5V	7	14	10.5	5V	6	13				
150	13.2	5V	7	15.5	10.5	5V	7	13.5				
200	15.0	5V	8	16	13.2	5V	8	13				
250	15.0	8V	6	28	14.0	5V	9	14				
300	16.0	8V	7	27	14.0	5V/8V	11 / 7	14 / 24				
350	16.5	8V	7	30	14.5	5V/8V	12 / 7	14 / 26				
400	17.5	8V	8	29	15.0	5V/8V	13 / 8	15 / 26				
450	18	8V	8	32	16.0	5V/8V	14 / 9	15 / 25				
500	18.5	8V	9	31	16.5	5V/8V	15 / 9	15 / 27				
600					17.5	8V	11	26				
700					19.0	8V	12	27				
800					20.0	8V	13	28				
NEMA sheave sizes												
Above - NEMA Sheave sizes												
Exceeds cast iron sheave rim speed - special sheave material required												

Notes:

1. Horsepowers are nameplate motor horsepowers, and RPMs are motor (driver) speeds.
2. NEMA minimum sheave diameters are from NEMA MG 1, Part 14, Table 14-1.
3. Consult Marathon Motors for applications utilizing (1) smaller sheaves and/or more belts than specified (2) variable speed applications (3) values outside these recommendations.
4. Selections are based on a 1.4 service factor, 5 to 1 speed ratio and various Power Transmission Manufacturer's catalogs used as reference.
5. These selections are for Narrow V-belt sections only. Consult Marathon Motors for details on conventional V-belt sections (A, B, C, D and E), or other belt types.
6. Belt deflected force is per section 4 of this document and is the average force required to deflect the center of a belt  $1/64$  of the belt span distance. Tolerance on this force is  $\pm 0.5$  lbf. for forces  $\leq 6$  lbs, and  $\pm 2$  lbf. for forces  $> 6$  lbs.

# CHAPTER V

## Electrical Characteristics and Connections

Voltage, frequency and phase of power supply should be consistent with the motor nameplate rating. A motor will operate satisfactorily on voltage within 10% of nameplate value, or frequency within 5%, or combined voltage and frequency variation not to exceed 10%.

### Voltage

---

Common 60 hz voltages for single-phase motors are 115 volt, 230 volt, and 115/230 volt.

Common 60 hz voltage for three-phase motors are 230 volt, 460 volt and 230/460 volt. Two hundred volt and 575 volt motors are sometimes encountered. In prior NEMA standards these voltages were listed as 208 or 220/440 or 550 volts. Motors with these voltages on the nameplate can safely be replaced by motors having the current standard markings of 200 or 208, 230/460 or 575 volts, respectively.

Motors rated 115/208-230 volt and 208-230/460 volt, in most cases, will operate satisfactorily at 208 volts, but the torque will be 20% - 25% lower. Operating below 208 volts may require a 208 volt (or 200 volt) motor or the use of the next higher horsepower, standard voltage motor.

### Phase

---

Single-phase motors account for up to 80% of the motors used in the United States but are used mostly in homes and in auxiliary low-horsepower industrial applications such as fans and on farms.

Three-phase motors are generally used on larger commercial and industrial equipment.

### Current (Amps)

---

In comparing motor types, the full load amps and/or service factor amps are key parameters for determining the proper loading on the motor. For example, never replace a PSC type motor with a shaded pole type as the latter's amps will normally be 50% - 60% higher. Compare PSC with PSC, capacitor start with capacitor start, and so forth.

## Hertz / Frequency

---

In North America 60 hz (cycles) is the common power source. However, most of the rest of the world is supplied with 50 hz power.

## Horsepower

---

Exactly 746 watts of electrical power will produce 1 HP if a motor could operate at 100% efficiency, but of course no motor is 100% efficient. A 1 HP motor operating at 84% efficiency will have a total watt consumption of 888 watts. This amounts to 746 watts of usable power and 142 watts loss due to heat, friction, etc. ( $888 \times .84 = 746 = 1 \text{ HP}$ ).

Horsepower can also be calculated if torque is known, using one of these formulas:

$$\text{HP} = \frac{\text{Torque (lb-ft)} \times \text{RPM}}{5,250}$$

$$\text{HP} = \frac{\text{Torque (oz-ft)} \times \text{RPM}}{84,000}$$

$$\text{HP} = \frac{\text{Torque (lb-in)} \times \text{RPM}}{63,000}$$

## Speeds

---

The approximate RPM at rated load for small and medium motors operating at 60 hz and 50 hz at rated volts are as follows:

	<u>60 hz</u>	<u>50 hz</u>	<u>Synch. Speed</u>
2 Pole	3450	2850	3600
4 Pole	1725	1425	1800
6 Pole	1140	950	1200
8 Pole	850	700	900

Synchronous speed (no-load) can be determined by this formula:

$$\frac{\text{Frequency (Hertz)} \times 120}{\text{Number of Poles}}$$

## Insulation Class

---

Insulation systems are rated by standard NEMA classifications according to maximum allowable operating temperatures. They are as follows:

Class	Maximum Allowed Temperature*	
A	105°C	(221°F)
B	130°C	(266°F)
F	155°C	(311°F)
H	180°C	(356°F)

\* Motor temperature rise plus maximum ambient

Generally, replace a motor with one having an equal or higher insulation class. Replacement with one of lower temperature rating could result in premature failure of the motor. Each 10°C rise above these ratings can reduce the motor's service life by one half.

## Service Factor

---

The service factor (SF) is a measure of continuous overload capacity at which a motor can operate without overload or damage, provided the other design parameters such as rated voltage, frequency and ambient temperature are within norms. Example: a 3/4 HP motor with a 1.15 SF can operate at .86 HP, (.75 HP x 1.15 = .862 HP) without overheating or otherwise damaging the motor if rated voltage and frequency are supplied at the motor's leads. Some motors, including most Marathon Motors motors, have higher service factors than the NEMA standard.

It is not uncommon for the original equipment manufacturer (OEM) to load the motor to its maximum load capability (service factor). For this reason, do not replace a motor with one of the same nameplate horsepower but with a lower service factor. Always make certain that the replacement motor has a maximum HP rating (rated HP x SF) equal to or higher than that which it replaces. Multiply the horsepower by the service factor for maximum potential loading.

For easy reference, standard NEMA service factors for various horsepower motors and motor speeds are shown in this table.

HP	FOR DRIP PROOF MOTORS			
	Service Factor Synchronous Speed (RPM)			
	3600	1800	1200	900
1/6, 1/4, 1/3	1.35	1.35	1.35	1.35
1/2	1.25	1.25	1.25	1.25
3/4	1.25	1.25	1.15	1.15
1	1.25	1.15	1.15	1.15
1-1/2 up	1.15	1.15	1.15	1.15

The NEMA service factor for totally enclosed motors is 1.0. However, many manufacturers build TEFC with a 1.15 service factor.

## Capacitors

Capacitors are used on all fractional HP induction motors except shaded-pole, split-phase and polyphase. Start capacitors are designed to stay in circuit a very short time (3-5 seconds), while run capacitors are permanently in circuit. Capacitors are rated by capacity and voltage. Never use a capacitor with a voltage less than that recommended with the replacement motor. A higher voltage is acceptable.

## Efficiency

A motor's efficiency is a measurement of useful work produced by the motor versus the energy it consumes (heat and friction). An 84% efficient motor with a total watt draw of 400W produces 336 watts of useful energy ( $400 \times .84 = 336W$ ). The 64 watts lost ( $400 - 336 = 64W$ ) becomes heat.

## Encoders

Encoders are devices that translate a signal, whether motion into position or velocity feedback for a motion control system. Take a conveyor system as an application. You want to run the conveyor at 100 feet per minute. The motor that powers this conveyor has an encoder mounted to its shaft. Output from the encoder goes into the controller and as long as the output signal is telling the controller that everything is fine – the motor is running at the correct speed - it continues running at the current speed. If the load on the conveyor changes, like it is being

overloaded due to additional weight of product added to the conveyor, the controller should notice a change in pulses from the encoder, for the speed of the conveyor slows down from this additional weight, and the controller will send a signal to the motor to speed up to compensate for this load change. Once the load has been returned to the standard expected load, the control will again see a signal from the encoder and will slow the motor down to the needed speed.

There are two main types of Encoders, Rotary and Linear and each type can use different sensing technologies. They include Optical, Magnetic or Inductive. Optical Rotary encoders are the most common type used.

## Thermal Protection (Overload)

---

A thermal protector, automatic or manual, mounted in the end frame or on a winding, is designed to prevent a motor from getting too hot, causing possible fire or damage to the motor. Protectors are generally current- and temperature-sensitive. Some motors have no inherent protector, but they should have protection provided in the overall system's design for safety. Never bypass a protector because of nuisance tripping. This is generally an indication of some other problem, such as overloading or lack of proper ventilation.

Never replace nor choose an automatic-reset thermal overload protected motor for an application where the driven load could cause personal injury if the motor should restart unexpectedly. Only manual-reset thermal overloads should be used in such applications.

Basic types of overload protectors include:

**Automatic Reset:** After the motor cools, this line-interrupting protector automatically restores power. It should not be used where unexpected restarting would be hazardous.

**Manual Reset:** This line-interrupting protector has an external button that must be pushed to restore power to the motor. Use where unexpected restarting would be hazardous, as on saws, conveyors, compressors and other machinery.

**Resistance Temperature Detectors:** Precision-calibrated resistors are mounted in the motor and are used in conjunction with an instrument supplied by the customer to detect high temperatures.

## Shaft Grounding Devices

---

Shaft grounding is recommended (NEMA MG1 31.4.4.3) as an effective means of bearing protection for motors operated from inverter power. Shaft voltage occurs in motors powered by variable frequency inverters (VFD). These VFDs induce shaft voltages onto the shaft of the driven motor because of the extremely high speed switching of the insulated gate bipolar transistors (IGBTs) which produce the pulse width modulation used to control AC motors. The presence of high frequency ground currents can cause sparks, arcing and electrical shocks and can damage bearings. One grounding device is adequate to bleed down inverter-sourced shaft voltages, thereby protecting both bearings for motors as large as 6085 frame.

There are four common techniques that can minimize or eliminate this bearing damage caused by these ground currents" Faraday shield, insulated bearings or ceramic bearings, a ground brush or a grounding ring. Shielding the cable or wire between the motor and the VFD can also significantly improve these spikes as well.

### Faraday Shield:

---

An electrostatic shielded induction motor (ESIM) is one approach to the shaft-voltage problem, as the insulation reduces voltage levels below the dielectric breakdown. This effectively stops bearing degradation and offers one solution to accelerated bearing wear caused by fluting, induced by VFDs.

### Grounding Brush:

---

Grounding the shaft by installing a grounding device provides an alternate low-impedance path from the motor shaft to the motor case. This channels the current away from the bearings. It significantly reduces shaft voltage, and therefore bearing current, by not allowing voltage to build up on the rotor.

### Shaft Grounding Ring:

---

A shaft grounding ring (SGR) is similar to a grounding brush, except that this brush makes use of conductive micro fibers, creating a low impedance path from the motor.

## Insulated Bearings:

---

Insulated or ceramic bearings eliminate the path to ground through the bearing for current to flow.

## Torque-speed Characteristics of Motors:

---

- The amount of torque produced by a motor generally varies with speed.
- This Torque-Speed characteristic depends on the type and design of a motor, and is often shown on a Torque-Speed graph.

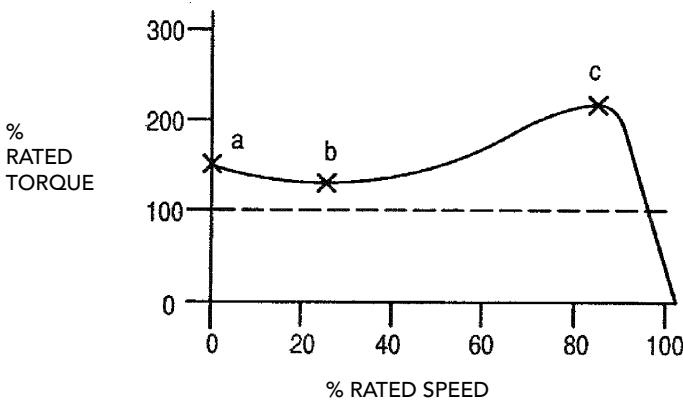

Figure 2.2  
Typical Torque-Speed Graph

- Some important factors indicated by the graph include:
  - (a) Starting torque - the torque produced at zero speed;
  - (b) Pull-up torque - the minimum torque produced during acceleration from standstill to operating speed;
  - (c) Breakdown torque - the maximum torque that the motor can produce before stalling.

## Individual Branch Circuit Wiring

---

All wiring and electrical connections should comply with the National Electrical Code (NEC) and with local codes and practices. Undersized wire between the motor and the power source will limit the starting and load carrying abilities of the motor. The recommended copper wire and transformer sizes are shown in the following charts.

### Single Phase Motors - 230 Volts

Transformer		Distance – Motor to Transformer (Feet)				
HP	kVA	100	150	200	300	500
1.5	3	10	8	8	6	4
2	3	10	8	8	6	4
3	5	8	8	6	4	2
5	7.5	6	4	4	2	0
7.5	10	6	4	3	1	0

WIRE GAGE

## Three Phase Motors - 230 & 460 Volts

Transformer			Distance – Motor to Transformer (Feet)				
HP	Volts	kVA	100	150	200	300	500
1.5	230	3	12	12	12	12	10
1.5	460	3	12	12	12	12	12
2	230	3	12	12	12	10	8
2	460	3	12	12	12	12	12
3	230	5	12	10	10	8	6
3	460	5	12	12	12	12	10
5	230	7.5	10	8	8	6	4
5	460	7.5	12	12	12	10	8
7.5	230	10	8	6	6	4	2
7.5	460	10	12	12	12	10	8
10	230	15	6	4	4	4	1
10	460	15	12	12	12	10	8
15	230	20	4	4	4	2	0
15	460	20	12	10	10	8	6
20	230	Consult	4	2	2	1	0
20	460		10	8	8	6	4
25	230	Local	2	2	2	0	0
25	460		8	8	6	6	4
30	230	Power	2	1	1	0	0
30	460		8	6	6	4	2
40	230	Company	1	0	0	0	0
40	460		6	6	4	2	0
50	230		1	0	0	0	0
50	460		4	4	2	2	0
60	230		1	0	0	0	0
60	460		4	2	2	0	0
75	230		0	0	0	0	0
75	460		4	2	2	0	0

WIRE GAGE

## Motor Starters

---

As their name implies, motor starters apply electric power to a motor to begin its operation. They also remove power to stop the motor. Beyond merely switching power on and off, starters include overload protection, as required by the National Electrical Code. The code also usually requires a disconnect and short circuit protection on motor branch circuits. Fused disconnects and circuit breakers provide this and are often incorporated into a motor starter enclosure, resulting in a unit referred to as a combination starter.

### Across The Line Starting of Induction Motors

---

- An across the line starter is the least expensive option and is usually used for induction motors.
- All NEMA design induction motors up to 200 HP, and many larger ones, can withstand full voltage starts.
- Manual starters are often used for smaller motors - up to about 10 HP. They consist of a switch with one set of contacts for each phase and a thermal overload device. The starter contacts remain closed if power is removed from the circuit and the motor restarts when power is reapplied.

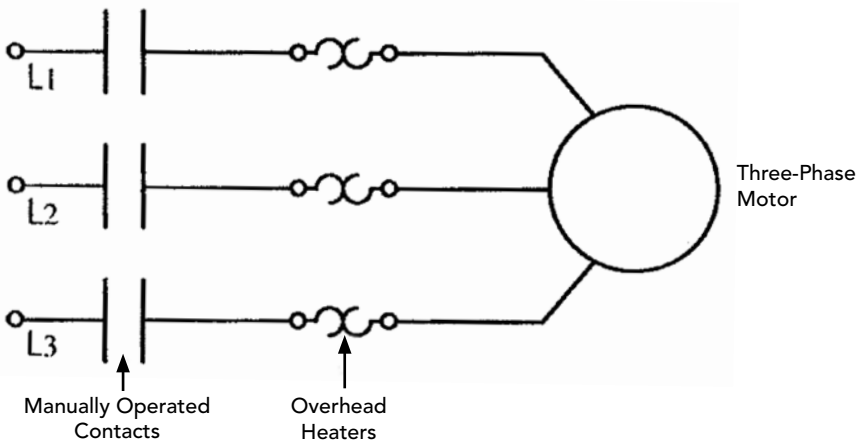

Figure 4.1  
Manual Starter

## Magnetic Starters

- Magnetic starters are used with larger motors or where greater control is desired. The main element of the starter is the contactor, which is a set of contacts operated by an electromagnetic coil. Energizing the coil causes the contacts A to close, allowing large currents to be initiated and interrupted by a control signal. The control voltage need not be the same as the motor supply voltage, and is often low voltage allowing the start and stop controls to be located away from the power circuit.

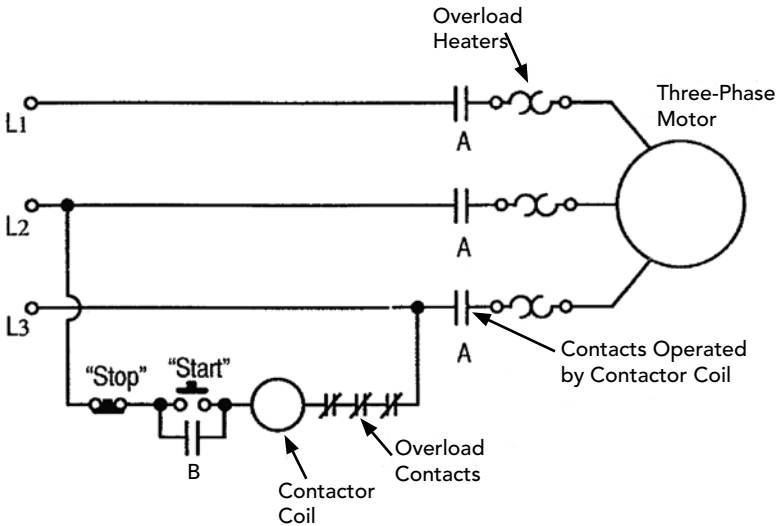

Figure 4.2  
Magnetic Starter

- Closing the starter button contacts energizes the contactor coil. An auxiliary contact, B, on the contactor is wired to seal in the coil circuit. The contactor de-energizes if the control circuit is interrupted by operating the stop button or if power is lost.
- The overload contacts are arranged so an overload trip on any phase will cause all phases to open.
- Contactors are rated for various operating voltages and are sized according to motor HP and type of duty expected.

## Reduced Voltage Starters

---

- If the driven load or the power distribution system cannot accept a full voltage start, some type of reduced voltage or “soft” starting scheme must be used.
- Typical reduced voltage starters are: primary resistance starters, autotransformers, part winding starters, wye-delta and solid state starters.
- These devices can only be used where low starting torque is acceptable.

### Primary Resistance Starters

---

- Closing the contacts at A connects the motor to the supply via resistors which provide a voltage drop to reduce the starting voltage available to the motor.
- The resistor’s value is chosen to provide adequate starting torque while minimizing starting current.
- Motor inrush current declines during acceleration, reducing the voltage drop across the resistors and providing more motor torque. This results in smooth acceleration.
- After a set period of time, contacts A open and the resistors are shorted out by contacts B, applying full voltage to the motor.

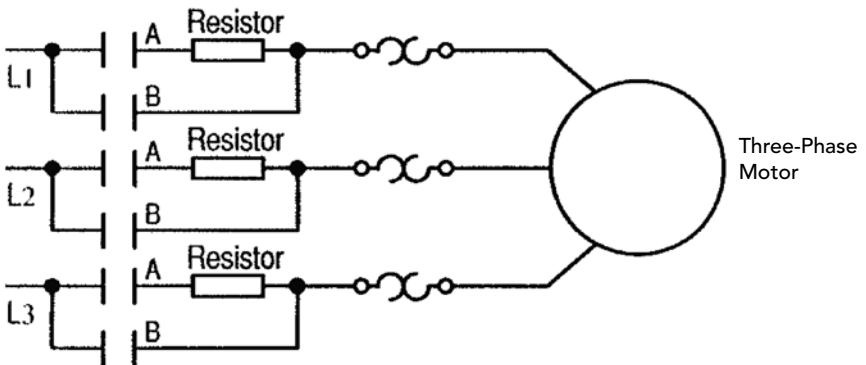

Figure 4.3  
Primary Resistance Starter

## Autotransformer Starters

- An autotransformer is a single winding transformer on a laminated core with taps at various points on the winding. The taps are usually expressed as a percentage of the total number of turns and thus percentage of applied voltage output.
- Three autotransformers are connected in a wye configuration or two in an open delta configuration, with taps selected to provide adequate starting current.
- The motor is first energized at a reduced voltage by closing contacts A.

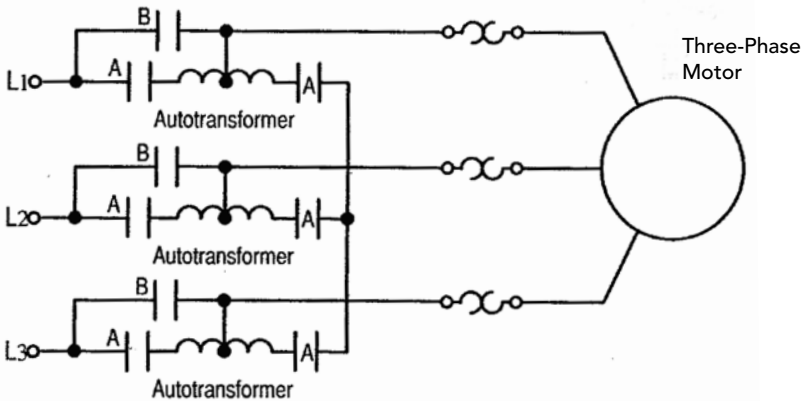

Figure 4.4  
Autotransformer Starter

- After a short time, the autotransformers are switched out of the circuit by opening contacts A and closing contacts B, thus applying full voltage to the motor.
- The autotransformers need not have high capacity as they are only used for a very short period of time.

## Wye-Delta Starting

- Wye-Delta Starting can be used with motors where all six leads of the stator winding are available (on some motors only three leads are accessible).

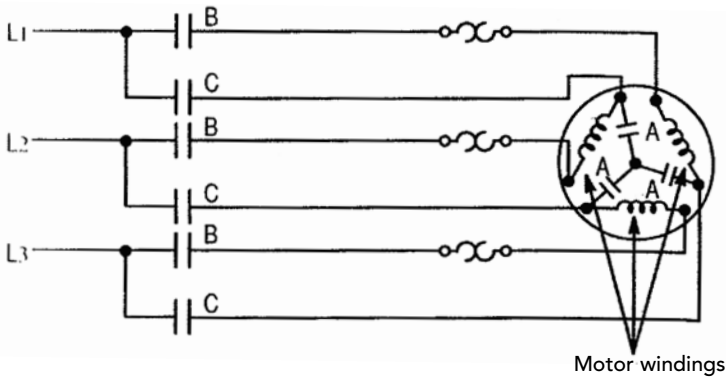

Figure 4.5  
Wye-Delta Starter

- By first closing contacts A and B, the windings are connected in a wye configuration which presents 57% of rated voltage to the motor.
- Full voltage is then applied by reconnecting the motor in a delta configuration by closing contacts C and opening those at A.
- The starting current and torque are 33% of their full voltage ratings, limiting applications to loads requiring very low starting torque.

## Part Winding Starters

---

- Part winding starters are sometimes used on motors wound for dual voltage operation such as a 230/460 V motor. These motors have two sets of winding connected in parallel for low voltage, and in series for high voltage operation.
- When used on the lower voltage, they can be started by first energizing only one winding, limiting starting current and torque to approximately one half of the full voltage values.
- The second winding is then connected normally once the motor nears operating speed.

# Reading a Marathon Motors Model Number

There is no independently established standard for setting up a motor's model number, but the procedure is typically tied to descriptions of various electrical and mechanical features. While other manufacturers use other designations, here is how Marathon Motors model numbers are configured.

Example (For Fractional): 1PC48C17D2000AP

This is a breakdown of the model on the nameplate:

1	P	C	48	C	17	D	2000	A	P
1	2	3	4	5	6	7	10	11	12

This is a breakdown of the model in the catalog:

48	C	17	D	2000
4	5	6	7	10

Example (For Integral): 2QA215TBDRA7076ALL

This is a breakdown of the model on the nameplate:

2	Q	A	215T	B	D	R	A	7076	AL	L
1	2	3	4	5	7	8	9	10	11	12

This is a breakdown of the model in the catalog:

215T	B	D	R	A	7076
4	5	7	8	9	10

1. **Date Code** - Year of Manufacture  
(Not shown in catalog listings.)
2. **Thermal Protection** (Not shown in catalog listings.)

	UL Recognized Motor Protector <u>Combination</u>	UL Recognized Motor <u>Construction</u>
Automatic Reset	Automatic Reset	Automatic Reset
Q	Yes	Yes
S	No	No
U	No	Yes
W	#	Yes
Manual Reset	Manual Reset	Manual Reset
P	Yes	Yes
Z	No	Yes
X	No	No
None	None	None
V	No	Yes

## HOW TO READ A MODEL NUMBER: Continued

# Motor protector combination is U.L. recognized only if motor is used in direct drive fan duty application, and is under locked rotor condition, or is running under no-load condition.

3. **Date Code** - Month of Manufacturer (Not shown in catalog listings.)
4. **NEMA Frame Size** - (Integral motors - T and U designate standard shaft, TS and US designate short shaft)

### 5. **Electrical Type**

Single Phase:

- A = Permanent split capacitor
- B = Capacitor start, capacitor run
- C = Capacitor start, induction run
- N = Split phase start, capacitor run
- S = Split phase

Three Phase:

- T = Three phase
- H = Inverter Duty/IEEE841 Inverter Duty
- V = Medium Voltage

DC Power:

- E = Permanent Magnet DC

### 6. **RPM or Speed at 60 Hz (Fractional Only)**

- 34 = 2-Pole, 3600 rpm
- 17 = 4-Pole, 1800 rpm
- 11 = 6-Pole, 1200 rpm
- 8 = 8-Pole, 900 rpm

### 7. **Enclosure**

- D = Dripproof
- E = Explosion proof, non-ventilated
- F = Totally enclosed, fan cooled
- G = Explosion proof, fan cooled
- O = Open
- P = Partial
- S = Semi-enclosed
- T = Totally enclosed, non-ventilated
- V = Washdown, non-ventilated
- W = Washdown, fan cooled

## HOW TO READ A MODEL NUMBER: Continued

### 8. Frame Construction

#### Integral

L = Aluminum (Full Frame)  
Y = Aluminum (Full Frame)  
Z = Aluminum (High Mount Down Frame)  
H = Aluminum - Sourced  
R = Rolled Steel (Full Frame)  
W = Rolled Steel (Full Frame)  
X = Rolled Steel (High Mount Down Frame)  
B = Rolled Steel - Sourced  
S = Cast Iron (Full Frame)  
N = Cast Iron (Full Frame)  
P = Cast Iron (High Mount Down Frame)  
C = Cast Iron - Sourced  
D = Stainless Steel

#### Fractional

B = Rolled Steel - Sourced  
D = Stainless Steel - Sourced  
U = Frameless - Sourced

9. **Style Letter** (A, B, C, etc. indicate redesign)

10. **Sequence Number**

11. **Minor Modification Letter(s)**

**Fractional - 1 letter; Integral - 2 letters**

12. **Manufacturing Code** - A code for the factory where the motor was manufactured.

**Example ("harmonized" motor design):**

<u>A</u>	<u>B</u>	<u>C</u>	<u>D</u>	<u>E</u>	<u>F</u>	<u>G</u>	<u>H</u>	<u>I</u>
5	KH	3	6	K	G	142	-	X

**A. Rotating Device**

**B. Type of Winding**

KH - Split Phase  
KC - Capacitor Start, Induction Run  
K - Polyphase  
KCP - Permanent Split Capacitor  
KCR - Capacitor Start, Capacitor Run

**C. Lamination Size**

3 - 48 frame, 4 - 56 frame

## HOW TO READ A MODEL NUMBER: Continued

### D. Length of Frame

	48 frame	56 frame
2	5.17	5.73
3	5.42	6.63
4	None	None
5	5.80	7.11
6	6.23	None
7	6.63	7.63
8	7.23	8.44
9	Spec.	Spec.

### E. Stack Length

A - 5/8"	F - 1-1/4"	L - 1-7/8"	S - 3.0"
B - 3/4"	G - 1-3/8"	M - 2.0"	T - 3-1/4"
C - 7/8"	H - 1-1/2"	N - 2-1/4"	U - 3-1/2"
D - 1.0"	J - 1-5/8"	P - 2-1/2"	W - 4.0"
E - 1-1/8"	K - 1-3/4"	R - 2-3/4"	Q - Spec.

### F. Endshield Construction

- G & N - Aluminum
- K - Steel
- C - Cap/Can

### G. Sequence Number

### H. Current Revision (blank if original)

### I. Type of Overload

- X - UL Auto running & locked rotor
- Y - UL Manual running & locked rotor
- S - UL Auto locked rotor
- T - Non-UL Auto running & locked rotor
- U - Non-UL Manual running & locked rotor
- V - Thermostat
- W - UL Motor Parts

# Major Components

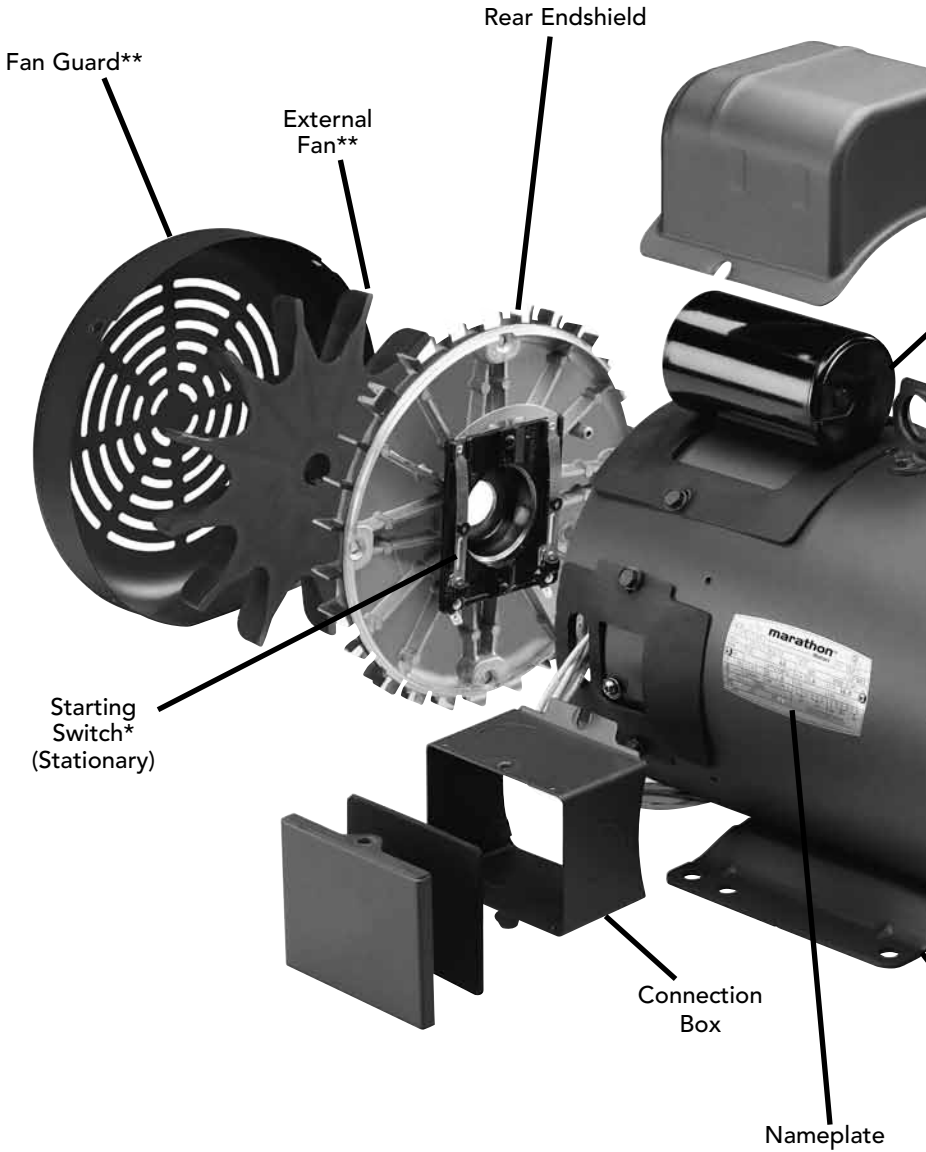

# of an Electric Motor

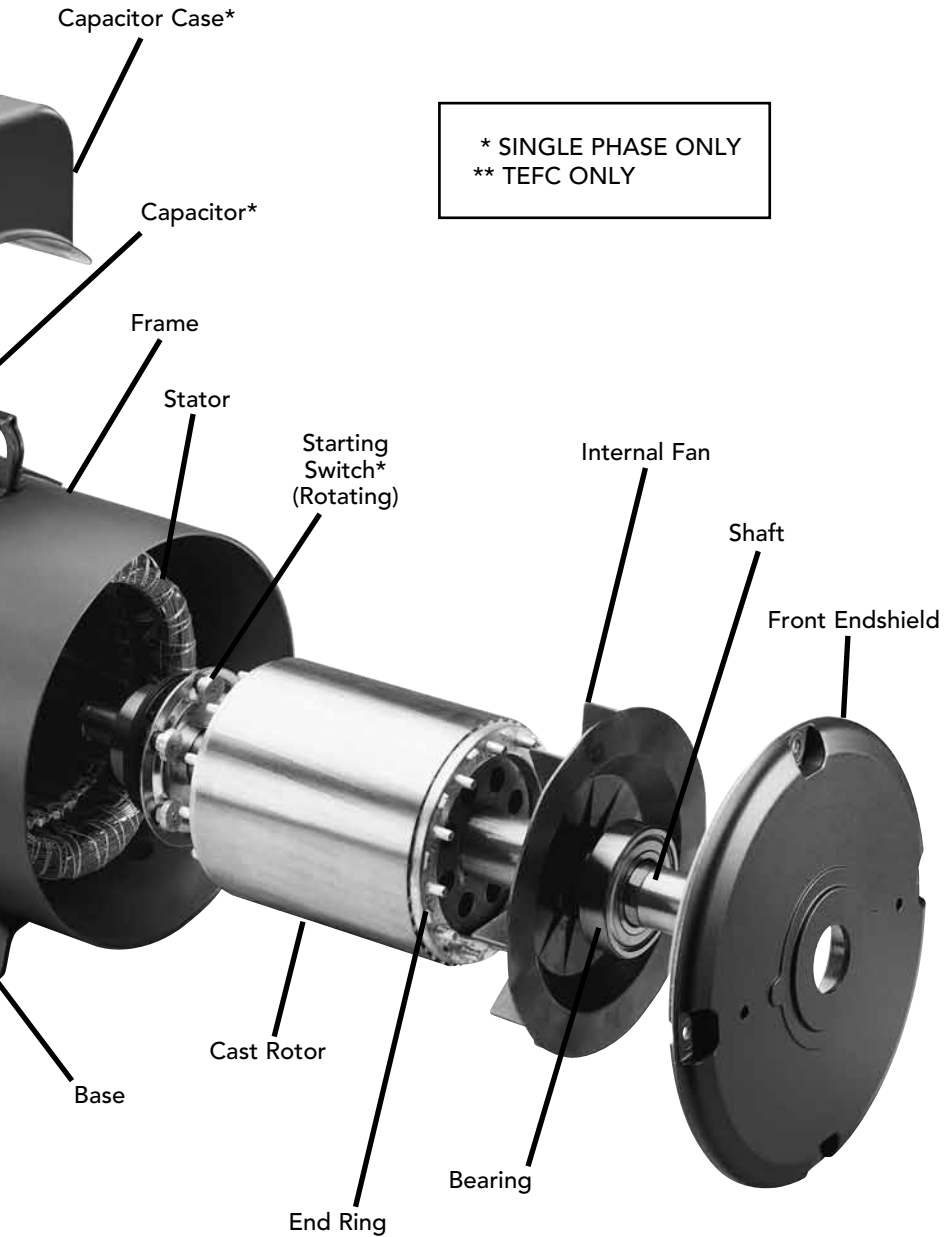

# CHAPTER VI

## Metric (IEC) Designations and Dimensions

The International Electrotechnical Commission (IEC) is a European-based organization that publishes and promotes worldwide mechanical and electrical standards for motors, among other things. In simple terms, it can be said that IEC is the international counterpart to the National Electrical Manufacturers Association (NEMA), which publishes the motor standards most commonly used throughout North America.

Dimensionally, IEC standards are expressed in metric units.

### IEC / NEMA Dimensional Comparison

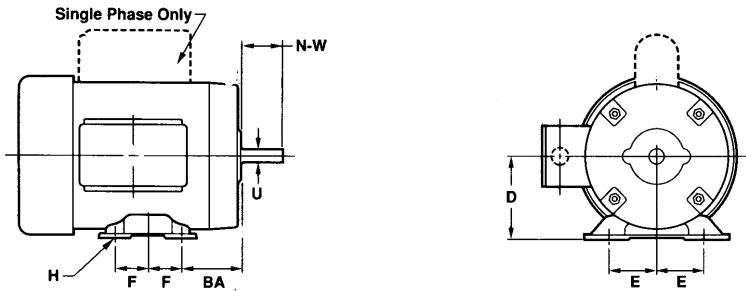

### NOTES

\* Shaft dimensions of these IEC frames may vary between manufacturers.

\*\* Horsepower listed is closest comparable rating with similar mounting dimensions. In some instances, this results in a greater HP rating than required. For example, 37 kW 4 pole converts to 50 HP but nearest HP rating in the NEMA frame having comparable dimensions is 75 HP. OBSERVE CAUTION if the drive train or driven load is likely to be damaged by the greater HP.

Equivalent HP can be calculated by multiplying the kW rating by 1.341.  
Multiply HP by .7457 to convert HP of kW.

To convert from millimeters to inches multiply by .03937.

To convert from inches to millimeters multiply by 25.

IEC	NEMA	Dimensions in Millimeters							KW/HP** Frame Assignments		
		D	E	F	H	U	BA	N-W	3 Phase – TEFC		
									2 Pole	4 Pole	6 Pole
56	NA	56	45	35.5	5.8	9	36	20	–	–	–
63	NA	63	50	40	7	11	40	23	.25KW 1/3HP	.18KW 1/4HP	–
71	42	71 66.7	56 44.5	45 21.4	7 7.1	14 9.5	45 52.4	30	.55 3/4	.37 1/2	–
80	48	80 76.2	62.5 54	50 34.9	10 8.7	19 12.7	50 63.5	40 38.1	1.1 1-1/2	.75 1	.55KW 3/4HP
90S	56	90 88.9	70 61.9	50 38.1	10 8.7	24 15.9	56 69.9	50 47.6	1.5 2	1.1 1-1/2	.75 1
90L	56	90 88.9	70 69.8	62.5 50.8	10 8.7	24 22.2	56 57.2	50 57.2	2.2 3	1.5 2	1.1 1-1/2
100L	145T	100 88.9	80 69.8	70 63.5	12 8.7	28 22.2	63 57.2	60 57.2	3 4	2.2 3	1.5 2
112L	182T	112 114.3	95 95.2	57 57.2	12 10.7	28 28	70 70	60 69.9	3.7 5	2.2 3	1.5 2
112M	184T	112 114.3	95 95.2	70 68.2	12 10.7	28 28	70 70	60 69.9	3.7 5	4 5-4/5	2.2 –
132S	213T	132 133.4	108 108	70 69.8	12 10.7	38 34.9	89 89	80 85.7	7.5 10	5.5 7-1/2	3 –
132M	215T	132 133.4	108 108	89 88.8	12 10.7	38 34.9	89 89	80 85.7	– –	7.5 10	5.5 7-1/2
160M*	254T	160 158.8	127 127	105 104.8	15 13.5	42 41.3	108 108	110 101.6	15 20	11 15	7.5 10
160L*	256T	160 158.8	127 127	127 127	15 13.5	42 41.3	108 108	110 101.5	18.5 25	15 20	11 15
180M*	284T	180 177.8	139.5 139.8	120.5 120.2	15 13.5	48 47.6	121 121	110 117.5	22 –	18.5 25	– –
180L*	286T	180 177.8	139.5 139.8	139.5 139.8	15 13.5	48 47.6	121 121	110 117.5	22 30	22 30	15 20
200M*	324T	180 203.3	159 158.8	133.5 133.4	19 16.7	55 54	133 133	110 133.4	30 40	30 40	– –
200L*	326T	200 203.2	159 158.8	152.5 152.4	19 16.7	55 54	133 133	110 133.4	37 50	37 50	22 30
225S*	364T	225 228.6	178 117.8	143 142.8	19 16.7	60 60.3	149 149	140 149.2	– –	37 50/75	30 40
225M*	365	225 228.6	178 177.8	155.5 155.6	19 16.7	60 60.3	149 149	140 149.2	45 60/75	45 60/75	37 50
250M*	405T	250 254	203 203.2	174.5 174.6	24 20.6	65 73	168 168	140 182.2	55 75/100	55 75/100	– –
280S*	444T	280 279.4	228.5 228.6	184 184.2	24 20.6	75 85.7	190 190	140 215.9	– –	– –	45 60/100
280M*	445T	280 279.4	228.5 228.6	209.5 209.6	24 20.6	75 85.7	190 190	140 215.9	– –	– –	55 75/125

See notes on facing page.

## IEC Enclosure Protection Indexes

Like NEMA, IEC has designations indicating the protection provided by a motor's enclosure. However, where NEMA designations are in words, such as Open Drip Proof or Totally Enclosed Fan Cooled, IEC uses a two-digit Index of Protection (IP) designation. The first digit indicates how well-protected the motor is against the entry of solid objects; the second digit refers to water entry.

By way of general comparison, an IP 23 motor relates to Open Drip Proof, IP 44 to totally enclosed.

Marathon Motors stock General Purpose, ODP, motors are typically rated at IP23 and our TEFC, General Purpose, motors are typically listed as IP43 or IP54.

Protection Against Solid Objects		Protection Against Liquids	
No.	Definition	No.	Definition
0	No protection.	0	No protection.
1	Protected against solid objects of over 50mm (e.g. accidental hand contact).	1	Protected against water vertically dripping (condensation).
2	Protected against solid objects of over 12mm (e.g. finger).	2	Protected against water dripping up to 15° from the vertical.
3	Protected against solid objects of over 2.5mm (e.g. tools, wire).	3	Protected against rain falling at up to 60° from the vertical.
4	Protected against solid objects of over 1mm (e.g. thin wire).	4	Protected against water splashes from all directions.
5	Protected against dust.	5	Protected against jets of water from all directions.
6	Totally protected against dust. Does not involve rotating machines.	6	Protected against jets of water comparable to heavy seas.
		7	Protected against the effects of immersion to depths of between 0.15 and 1m.
		8	Protected against the effects of prolonged immersion at depth.

## IEC Cooling, Insulation and Duty Cycle Indexes

---

IEC has additional designations indicating how a motor is cooled (two-digit IC codes). For most practical purposes, IC 01 relates to a NEMA open design, IC 40 to Totally Enclosed Non-Ventilated (TENV), IC 41 to Totally Enclosed Fan Cooled (TEFC), and IC 48 to Totally Enclosed Air Over (TEAO).

IEC winding insulation classes parallel those of NEMA and in all but very rare cases use the same letter designations.

Duty cycles are, however, different. Where NEMA commonly designates either continuous, intermittent, or special duty (typically expressed in minutes), IEC uses eight duty cycle designations.

- S1 Continuous duty. The motor works at a constant load for enough time to reach temperature equilibrium.
- S2 Short-time duty. The motor works at a constant load, but not long enough to reach temperature equilibrium, and the rest periods are long enough for the motor to reach ambient temperature.
- S3 Intermittent periodic duty. Sequential, identical run and rest cycles with constant load. Temperature equilibrium is never reached. Starting current has little effect on temperature rise.
- S4 Intermittent periodic duty with starting. Sequential, identical start, run and rest cycles with constant load. Temperature equilibrium is not reached, but starting current affects temperature rise.
- S5 Intermittent periodic duty with electric braking. Sequential, identical cycles of starting, running at constant load, electric braking, and rest. Temperature equilibrium is not reached.
- S6 Continuous operation with intermittent load. Sequential, identical cycles of running with constant load and running with no load. No rest periods.
- S7 Continuous operation with electric braking. Sequential identical cycles of starting, running at constant load and electric braking. No rest periods.

- S8 Continuous operation with periodic changes in load and speed.  
Sequential, identical duty cycles of start, run at constant load and given speed, then run at other constant loads and speeds.  
No rest periods.

## IEC Design Types

---

The electrical performance characteristics of IEC Design N motors in general mirror those of NEMA Design B – the most common type of motor for industrial applications. By the same token, the characteristics of IEC Design H are nearly identical to those of NEMA Design C. There is no specific IEC equivalent to NEMA Design D. (See chart on Page 13 for characteristics of NEMA design types.)

## IEC Mounting Designations

---



Three common IEC mounting options are shown in this photo. From left, a B5 flange, B14 face and rigid B3 base. In this case, any of the options can be bolted to a modularly designed round-body IEC 71 frame motor.

# CHAPTER VII

## Motor Maintenance

Motors, properly selected and installed, are capable of operating for many years with a reasonably small amount of maintenance.

Before servicing a motor and motor-operated equipment, disconnect the power supply from motors and accessories. Use safe working practices during servicing of the equipment.

Clean motor surfaces and ventilation openings periodically, preferably with a vacuum cleaner. Heavy accumulations of dust and lint will result in overheating and premature motor failure.

### Lubrication Procedure

---

Motors 10 HP and smaller are usually lubricated at the factory to operate for long periods under normal service conditions without re-lubrication. Excessive or too frequent lubrication may actually damage the motor. Follow instructions furnished with the motor, usually on the nameplate or terminal box cover or on a separate instruction. If instructions are not available, re-lubricate according to the chart on the next page. Use high-quality ball bearing grease. Grease consistency should be suitable for the motor's insulation class. For Class B, F or H, use a medium consistency polyurea grease such as EXXON POLYREX® EM.

If the motor is equipped with lubrication fitting, clean the fitting tip, and apply grease gun. Use one to two full strokes on NEMA 215 frame and smaller motors. Use two to three strokes on NEMA 254 through NEMA 365 frame. Use three to four strokes on NEMA 404 frames and larger. For motors that have grease drain plugs, remove the plugs and operate the motor for 20 minutes before replacing the plugs.

For motors equipped with slotted head grease screws, remove the screw and insert a two-inch to three-inch long grease string into each hole on motors in NEMA 215 frame and smaller.

Insert a three-inch to five-inch length on larger motors. For motors having grease drain plugs, remove the plug and operate the motor for 20 minutes before replacing the plugs.

## Relubrication Intervals Chart For Motors Having Grease Fittings

Hours of Service Per Year	HP Range	Suggested Relube Interval
5000	1/18 to 7 1/2 10 to 40 50 to 100	5 years 3 years 1 year
Continuous Normal Applications	to 7 1/2 10 to 40 50 to 100	2 years 1 year 9 months
Seasonal Service - Motor is idle for 6 months or more	All	1 year (beginning of season)
Continuous high ambient, high vibrations, or where shaft end is hot	1/8 to 40 50 to 150	6 months 3 months

*Caution: Keep grease clean. Lubricate motors at a standstill. Do not mix petroleum grease and silicone grease in motor bearings.*

# DC Motor Trouble-Shooting Chart



1. Disconnect power to the motor before performing service or maintenance.
2. Discharge all capacitors before servicing motor.
3. Always keep hands and clothing away from moving parts.
4. Be sure required safety guards are in place before starting equipment.

Problem	Likely Causes	What To Do
Motor fails to start upon initial installation.	Motor is miswired. No output power from controller. Motor damaged and the fan guard is contacting the cooling fan.	Verify that the motor is wired correctly. Measure voltage coming from the controller. Replace fan guard.
Motor runs in the wrong direction.	Motor damaged and the armature is rubbing against the magnets.	Disassemble motor and see if the armature can be realigned by reassembly. Motor may have to be replaced.
Motor runs ok but has a clicking noise.	Incorrect wiring. Suspect a burr on the commutator.	Interchange the two motor leads. Stone the armature commutator with a commutator stone to remove burr.

# DC Motor Trouble-Shooting Chart (cont'd)

<b>Problem</b>	<b>Likely Causes</b>	<b>What To Do</b>
<p>Motor has been running, then fails to start.</p>	<p>Fuse or circuit breaker is tripped.</p> <p>Armature is shorted or went to ground. Motor may make a humming noise and the circuit breaker or fuse will trip.</p> <p>The brushes may be worn down too far and no longer make contact with the commutator.</p> <p>Controller may be defective.</p>	<p>Replace the fuse or reset the breaker</p> <p>Disassemble motor and inspect the armature for a burnt coil. Inspect the commutator for burnt bars. If this condition exists, the motor needs to be replaced. To test, set your OHM to the RX1 scale, touch probes to bars 180 degrees apart all around the commutator. The reading should be equal.</p> <p>Inspect the brushes to make sure that they are still making contact with the commutator. Refer to manufacturer's recommended brush length chart.</p> <p>Verify voltage is coming out of the controller.</p>
<p>Motor runs but loses power.</p>	<p>Load has increased.</p> <p>Motor controller not properly set.</p> <p>Motor may have an open connection.</p> <p>Brushes may not be seated properly or worn beyond their useful length.</p>	<p>Verify the load has not changed. Measure the amp draw of motor against the full load amp rating of the motor. If the amp draw is higher than rating, motor is undersized for application.</p> <p>Check controller manual for adjustments. The torque and/or IR compensation settings may need adjustment.</p> <p>Inspect the armature for an open connection.</p> <p>Verify that the brushes are properly seated and measure their length against the recommended brush length chart.</p>
<p>Motor takes too long to accelerate.</p>	<p>Motor controller not properly set.</p> <p>Brushes are worn.</p> <p>Bearings may be defective.</p>	<p>The accel trim pot of the controller should be adjusted.</p> <p>Verify brush length.</p> <p>Inspect bearings for proper service. Noisy or rough bearings should be replaced.</p>

# AC Motor Trouble-Shooting Chart



1. Disconnect power to the motor before performing service or maintenance.
2. Discharge all capacitors before servicing motor.
3. Always keep hands and clothing away from moving parts.
4. Be sure required safety guards are in place before starting equipment.

Problem	Likely Causes	What To Do
Motor fails to start upon initial installation.	<p>Motor is miswired.</p> <p>Motor damaged and rotor is striking stator.</p> <p>Fan guard bent and contacting fan.</p>	<p>Verify that the motor is wired correctly.</p> <p>May be able to reassemble; otherwise, motor should be replaced.</p> <p>Replace fan guard.</p>
Motor had been running, then fails to start.	<p>Fuse or circuit breaker tripped.</p> <p>Stator is shorted or went to ground. Motor will make a humming noise and the circuit breaker or fuse will trip.</p> <p>Motor overloaded or load jammed.</p> <p>Capacitor (on shingle phase motor) may have failed.</p>	<p>Replace fuse or reset breaker.</p> <p>Disassemble motor and inspect windings and internal connections. A blown stator will show a burn mark. Motor must be replaced or the stator rewound.</p> <p>Inspect to see that the load is free. Verify amp draw of motor versus nameplate rating.</p> <p>First discharge capacitor. To check capacitor, set volt-ohm meter to RX100 scale and touch its probes to capacitor terminals. If capacitor is OK, needle will jump to zero ohms, and drift back to high. Steady zero ohms indicates a short circuit; steady high ohms indicates an open circuit.</p>

# AC Motor Trouble-Shooting Chart (cont'd)

Problem	Likely Causes	What To Do
Motor had been running, then fails to start. (cont'd)	Starting switch has failed.	Disassemble motor and inspect both the centrifugal and stationary switches. The weights of the centrifugal switch should move in and out freely. Make sure that the switch is not loose on the shaft. Inspect contacts and connections on the stationary switch. Replace switch if the contacts are burned or pitted.
Motor runs but dies down.	Voltage drop. Load increased.	If voltage is less than 10% of the motor's rating contact power company or check if some other equipment is taking power away from the motor. Verify the load has not changed. Verify equipment hasn't got tighter. If fan application verify the air flow hasn't changed.
Motor takes too long to accelerate.	Defective capacitor. Faulty stationary switch. Bad bearings. Voltage too low.	Test capacitor per previous instructions. Inspect switch contacts and connections. Verify that switch reeds have some spring in them. Noisy or rough feeling bearings should be replaced. Make sure that the voltage is within 10% of the motor's nameplate rating. If not, contact power company or check if some other equipment is taking power away from the motor.
Motor runs in the wrong rotation.	Incorrect wiring.	Rewire motor according to wiring schematic provided.
Motor overload protector continually trips.	Load too high.	Verify that the load is not jammed. If motor is a replacement, verify that the rating is the same as the old motor. If previous motor was a special design, a stock motor may not be able to duplicate the performance. Remove the load from the motor and inspect the amp draw of the motor unloaded. It should be less than the full load rating stamped on the nameplate.

# AC Motor Trouble-Shooting Chart (cont'd)

Problem	Likely Causes	What To Do
<p>Motor overload protector continually trips. (cont'd)</p>	<p>Ambient temperature too high.</p> <p>Protector may be defective.</p> <p>Winding shorted or grounded.</p>	<p>Verify that the motor is getting enough air for proper cooling. Most motors are designed to run in an ambient temperature of less than 40° C. (Note: A properly operating motor may be hot to the touch.)</p> <p>Replace the motor's protector with a new one of the same rating.</p> <p>Inspect stator for defects, or loose or cut wires that may cause it to go to ground.</p>
<p>Motor vibrates.</p>	<p>Motor misaligned to load.</p> <p>Load out of balance. (Direct drive application).</p> <p>Motor bearings defective.</p> <p>Rotor out of balance.</p> <p>Motor may have too much endplay.</p> <p>Winding may be defective.</p>	<p>Realign load.</p> <p>Remove motor from load and inspect motor by itself. Verify that motor shaft is not bent. Rule of thumb is .001" runout per every inch of shaft length.</p> <p>Test motor by itself. If bearings are bad, you will hear noise or feel roughness. Replace bearings. Add oil if the bearing is a sleeve bearing type or replace bearings. Add grease if bearings have grease fittings.</p> <p>Inspect motor by itself with no load attached. If it feels rough and vibrates but the bearings are good, it may be that the rotor was improperly balanced at the factory. Rotor must be replaced or rebalanced.</p> <p>With the motor disconnected from power turned shaft. It should move but with some resistance. If the shaft moves in and out too freely, this may indicate a preload problem and te bearings may need additional shimming.</p> <p>Test winding for shorted or open circuits. The amps may also be high. Replace motor or have stator rewind.</p>

# AC Motor Trouble-Shooting Chart (cont'd)

Problem	Likely Causes	What To Do
Bearings continuously fail.	<p>Load to motor may be excessive or unbalanced.</p> <p>High ambient temperature.</p>	<p>Besides checking load, also inspect drive belt tension to ensure it's not too tight may be too high. An unbalanced load will also cause the Bearings to fail.</p> <p>If the motor is used in a high ambient, a different type of bearing grease may be required. You may need to consult the factory or a bearing distributor.</p>
<p>The motor, at start up, makes a loud rubbing or grinding noise.</p> <p>Start capacitors continuously fail.</p>	<p>Rotor may be striking stator.</p> <p>The motor is not coming up to speed quickly enough.</p> <p>The motor is being cycled too frequently.</p> <p>Voltage to motor is too low.</p>	<p>Ensure that motor was not damaged in shipment. Frame damage may not be repairable. If you cannot see physical damage, inspect the motor's rotor and stator for strike marks. If signs of rubbing are present, the motor should be replaced. Sometimes simply disassembling and reassembling motor eliminates rubbing. Endbells are also sometimes knocked out of alignment during transportation.</p> <p>Motor may not be sized properly. Verify how long the motor takes to come up to speed. Most single phase capacitor start motors should come up to speed within three seconds. Otherwise the capacitors may fail.</p> <p>Verify duty cycle. Capacitor manufactures recommend no more than 20, three-second starts per hour. Install capacitor with higher voltage rating, or add bleed resistor to the capacitor.</p> <p>Verify that voltage to the motor is within 10% of the nameplate value. If the motor is rated 208-230V, the deviation must be calculated from 230V.</p> <p>Replace switch.</p>
Run capacitor fail.	<p>Starting switch may be defective, preventing the motor from coming out of start winding.</p> <p>Ambient temperature too high.</p> <p>Possible power surge to motor, caused by lightning strike or other high transient voltage.</p>	<p>Verify that ambient does not exceed motor's nameplate value. If a common problem, install surge protector.</p>

# CHAPTER VIII

## Common Motor Types and Typical Applications

### Alternating Current Designs

---

#### **Single Phase \* Rigid Base Mounted \* Capacitor Start \* Totally Enclosed Fan Cooled (TEFC) & Totally Enclosed Non-Vent (TENV)**

General purpose including compressors, pumps, fans, farm equipment, conveyors, material handling equipment and machine tools.

#### **Single Phase \* Rigid Base Mounted \* Capacitor Start \* Open Drip Proof (ODP)**

General purpose including compressors, pumps, conveyors, fans, machine tools and air conditioning units - usually inside or where protected from weather, dust and contaminants.

#### **Three Phase \* Rigid Base Mounted \* TEFC**

General purpose including pumps, compressors, fans, conveyors, machine tools and other applications where three-phase power is available.

#### **Three Phase \* Rigid Base Mounted \* ODP**

General purpose including pumps, compressors, machine tools, conveyors, blowers, fans and other applications requiring three-phase power, usually inside or where protected from weather, dust and contaminants.

#### **Single Phase \* NEMA C Face Less Base \* Capacitor Start \* TEFC & TENV**

Pumps, fans, conveyors, machine tools and gear reducers.

#### **Single Phase \* NEMA C Face Less Base \* Capacitor Start \* ODP**

Fans, blowers, compressors, tools and speed reducers.

#### **Three Phase \* NEMA C Face Less Base \* TEFC & TENV**

Fans, blowers, compressors, tools and speed reducers where three-phase power is suitable.

#### **Three Phase \* NEMA C Face Less Base \* ODP**

Fans, blowers, compressors, tools and speed reducers.

### **Wash-Thru and Multiguard Motors**

Used in applications involving moisture, vibration, dust and some chemical contact. The motor's windings are impregnated and encapsulated in a thermosetting that protects them from contaminants for long motor life.

### **Automotive Duty Motors**

Suited for a wide variety of tough applications found in automotive manufacturing facilities and other industries utilizing U-Frame motors. Meets or exceeds General Motors GM-7EH and -7EQ, Ford EM1 and Chrysler NPEM-100 specifications.

### **Crusher Duty Motors**

Ideally suited for size reduction equipment including rock crushers and pulverizers and other uses the aggregate and construction industries. They are designed for belted (radial) loads only utilizing roller bearings on the Drive-end side of the motor.

### **Washdown-Duty \* Single & Three Phase \* TENV & TEFC**

Extended life in applications requiring regular hose-downs with cleaning solutions, as in food processing and for applications in wet, high humidity environments. Also available in direct current designs.

### **Explosion Proof \* Single & Three Phase \* TENV & TEFC**

Designed and listed for application in hazardous environments having certain explosive gases or materials present on equipment, such as blowers, pumps, agitators or mixers.

### **Chemical Service Motors \* Rigid Base**

Petrochemical plants, foundries, pulp and paper plants, waste management facilities, chemical plants, tropical climates and other processing industry applications requiring protection against corrosion caused by severe environmental operating conditions.

### **Brakemotors \* Single & Three Phase**

Machine tools, hoists, conveyors, door operators, speed reducers, valves, etc., when stop and hold performance is required when power is removed from the motor by the use of a spring-set friction brake.

### **Resilient Mounted \* Single & Three Phase \* Moderate Starting Torques**

General purpose applications where quiet operation is preferred for fan and blower service.

**Resilient Mounted \* Single & Three Phase \* Two Speed \* Two Winding \* Variable Torque:**

Belted or fan-on-shaft applications.

**Rigid Mounted \* Totally Enclosed Air Over (TEAO) \* Single & Three Phase**

Dust-tight motors for shaft-mounted or belt-driven fans. The motor depends upon the fan's airflow to cool itself.

**HVAC Blower Motors \* Three Phase \* Automatic Reset Overload Protector \* Resilient Base \* ODP**

Heating, ventilating and air conditioning applications requiring moderate starting torque and thermal protection.

**Condenser Fan Motors \* Three Phase \* Belly Band Mount \* ODP**

For operating vertical shaft-up on condenser fan, air-over applications, such as rooftop air conditioning units.

**Two Speed \* Three Phase \* Variable Torque**

Fans, blowers and centrifugal pumps. Variable torque motors have horsepower ratings that vary as the square of the speed, while torque varies directly with the speed.

**Two Speed \* Three Phase \* Constant Torque**

Mixers, compressors, conveyors, printing presses, extractors, feeders and laundry machines. Constant torque motors are capable of developing the same torque for all speeds. Their horsepower ratings vary directly with the speed.

**Two Speed \* Three Phase \* Constant Horsepower**

Machine tools, such as drills, lathes, punch presses and milling machines. Constant horsepower motors develop the same horsepower at all operating speeds, and the torque varies inversely with the speed.

**Jet Pump Motors \* Single & Three Phase**

Residential and industrial pumps, plus swimming pool pumps. The pump impeller is mounted to the motor shaft.

**JM Pump Motors \* Single & Three Phase**

Continuous duty service on close-coupled pumps using NEMA JM mounting provisions. Commonly used for circulating and transferring fluids in commercial and industrial water pumps.

### **Compressor Duty \* Single & Three Phase**

Air compressor, pump-fan and blower duty applications which require high breakdown torque and overload capacity matching air compressor loading characteristics.

### **Woodworking Motors \* Single Phase \* TEFC**

High torques for saws, planers and similar woodworking equipment.

### **Instant Reversing Motors \* Resilient Mount \* Single Phase \* ODP**

Specially designed motors for use on instant-reversing parking gates, doors, slide gates or other moderate starting torque instant reversing application; capable of frequent reversing service.

### **Pressure Washer Pump Motors \* Rigid Mount & Rigid Mount with NEMA C Face \* Single Phase \* ODP**

Hot or cold pressure washers and steam cleaners.

### **IEC Metric Motors \* Three Phase**

For replacement on imported machined tools, textile machinery and other equipment having metric dimensioned motors. Also available in direct current designs.

### **Farm Duty \* High Torque & Extra High Torque \* Rigid Base Mount & C Face Less Base**

Severe agricultural equipment applications requiring high torques under adverse operating conditions such as low temperatures.

### **Agricultural Fan Duty \* Resilient & Rigid Base Mount \* Single & Three Phase \* TEAO**

Dust-tight fan and blower duty motors for shaft-mounted or belt-driven fans. The motor depends upon the fan's air flow to cool itself.

### **Feed-Auger Drive Motors \* Single Phase**

Dust-tight auger motors eliminate damage caused when the motor is over-speeded by an obstructed auger. Special flange mounts directly to the auger gear reducer.

### **Hatchery/Incubator Fan Motor \* Band Mounted \* Single Phase \* TEAO**

Replacement for use on poultry incubator fans. Includes extended through bolts for attaching farm shroud.

**Feather Picker Motor \* Rigid Mount \* Three Phase \* TEFC**

Washdown-duty motor replaces the MEYN drive motor of a processing machine that removes feathers from poultry.

**Milk Transfer Pump Motor \* Rigid Base \* Single Phase \* TENV**

Replacement in dairy milk pumps.

**Grain Stirring Motors \* Rigid Base \* Single Phase \* TEFC**

Designed to operate inside agricultural storage bins for stirring grain, corn, and other agricultural products during the drying and storage process.

**Irrigation Drive Motors \* C Face Less Base \* Three Phase \* TEFC**

For center pivot irrigation systems exposed to severe weather environments and operating conditions. Drives the tower that propels sprinklers in a circle around the well.

**Severe Duty and IEEE 841 Motors**

Designed to meet severe duty environments that you might find in chemical plants, foundries, Paper and Pulp mills or waste management facilities. IEEE-841 motors meet IP56 enclosure protection and approved for USCG Marine Duty, AP1, RP14F for offshore platforms.

## **Elevator Motors**

---

**Submersible Hydraulic Elevator Pump Motors**

Used in Elevator systems for applications in hydraulic passenger, service, freight and low-rise elevators.

**Hydraulic Elevator Pump Motors**

Used in Hydraulic pump passenger, service, freight and dumbwaiter low rise elevators

**VVVF (Variable Voltage Variable Frequency) Traction Elevator Hoist Motors**

Designed for Geared and Gearless Traction Elevators.

## Direct Current Designs

---

### **High-Voltage, SCR-Rated Brush-Type \* Permanent Magnet Field \* C Face With Removable Base \* TEFC**

Generally used for conveyors, machine tools, hoists or other applications requiring smooth, accurate adjustable-speed capabilities through the use of thyristor-based controls, often with dynamic braking and reversing also required. Usually direct-coupled to driven machinery, with the motor often additionally supported by a base for maximum rigidity. Such motors are also applicable where extremely high starting torque, or high intermittent-duty running torques are needed, even if the application may not require adjustable speed.

### **High-Voltage, SCR-Rated Brush-Type \* Permanent Magnet Field \* Washdown-Duty Enhancements \* C Face With Removable Base \* TENV**

Designed for extended life on food-processing machines or other high-humidity environments where adjustable speed is required.

### **Low-Voltage Brush-Type \* Permanent Magnet Field \* C Face With Removable Base \* TENV**

For installations operating from battery or solar power, or generator-supplied low-voltage DC. One key application is a pump operating off a truck battery. Like high-voltage counterparts, low-voltage designs provide linear speed/torque characteristics over their entire speed range, as well as dynamic braking, easy reversing and high torque.

# CHAPTER IX

## Gear Reducers and Gearmotors

A gear reducer, also called a speed reducer or gear box, consists of a set of gears, shafts and bearings that are factory-mounted in an enclosed, lubricated housing. Gear reducers are available in a broad range of sizes, capacities and speed ratios. Their job is to convert the input provided by a “prime mover” into output of lower RPM and correspondingly higher torque. In industry, the prime mover is most often an electric motor, though internal combustion engines or hydraulic motors may also be used.



*Cutaway view shows key components of an industrial-duty worm gear reducer. Note steel worm and bronze worm gear. Seals on both input and output shafts prevent lubricant leakage.*

There are many types of gear reducers using various gear types to meet application requirements as diverse as low first cost, extended life, limited envelope size, quietness, maximum operating efficiency, and a host of other factors. The discussion that follows is intended only as a brief outline of the most common industrial gear reducer types, their characteristics and uses.

### Right-Angle Worm Gear Reducers

---

The most widely used industrial gear reducer type is the right-angle worm reducer. Worm reducers offer long life, overload and shock load tolerance, wide application flexibility, simplicity and relatively low cost.

In a worm gear set, a threaded input shaft, called the worm, meshes with a worm gear that is mounted to the output shaft. Usually, the worm shaft is steel and the worm gear is bronze. This material combination

has been shown to result in long life, smooth operation, and noise levels acceptable for industrial environments.

The number of threads in the worm shaft, related to the number of teeth in the worm gear, determine the speed reduction ratio. Single-reduction worm gear reducers are commonly available in ratios from approximately 5:1 through 60:1. A 5:1 ratio means that motor input of 1750 RPM is converted to 350 RPM output. A 60:1 ratio brings output RPM of the same motor to 29 RPM. Greater speed reductions can be achieved through double-reduction – meaning two gear reducers coupled together.

The flip side of “geared-down” speed is “geared-up” torque. For the majority of gear reducers in North America, output torque is expressed in inch-pounds or foot-pounds. Outside of North America, the metric unit of torque, newton-meter, is most common. Output speed and output torque are the key application criteria for a gear reducer.

## Parallel-Shaft Gear Reducers

---

Parallel-shaft units are typically built with a combination of helical and spur gears in smaller sizes, and all helical gears in larger sizes. Helical gears, which have teeth cut in helixes to maximize gear-to-gear contact, offer higher efficiencies and quieter operation – though at a correspondingly higher cost than straight-tooth spur gears.

Single-reduction speed ratios are far more limited in parallel-shaft reducers than in right-angle worm reducers, but multiple reductions (or gear stages) fit easily within a single parallel-shaft reducer housing. As a result, the availability of higher ratios is usually greater in parallel-shaft reducers and gearmotors; ratios as high as 900:1 are common in small gearmotors.



*Combination of spur and helical gears can be seen in this cutaway view of a sub-fractional horsepower parallel-shaft gearbox. Note multiple gear stages.*

# Gearmotors

---



Three-phase NEMA C face AC motor combined with flanged worm gear reducer results in a “workhorse” industrial gearmotor. This straightforward mounting approach is common with motors ranging in sizes from fractional through 20 HP and larger.

An electric motor combined with a gear reducer creates a gearmotor. In sub-fractional horsepower sizes, integral gearmotors are the rule – meaning the motor and the reducer share a common shaft and cannot be separated. For application flexibility and maintenance reasons, a larger gearmotor is usually made up of an individual reducer and motor coupled together. This is most often accomplished by using a reducer having a NEMA C input flange mated to a NEMA C face motor.



At left, a quill-style input worm gear reducer uses a hollow input shaft and a shallow mounting flange. At right, extended mounting flange accommodates a solid-shaft to solid-shaft input with a flexible coupling joining the two shafts.

NEMA C flange reducers are of two basic types based on how the motor and reducer shafts are coupled. The most straightforward type, and the most commonly used in smaller horsepower applications, has a “quill” input – a hollow bore in the worm into which the motor’s shaft is inserted. The other type, involving a reducer having a solid input shaft, requires a shaft-to-shaft flexible coupling, as well as an extended NEMA C flange to accommodate the combined length of the shafts.

## Installation and Application Considerations

**Mounting:** In the majority of cases, gear reducers are base-mounted. Sometimes, mounting bolts are driven directly into pre-threaded holes in the reducer housing. Other times, accessory bases are used. Output flange mountings are also available.



*Quill-style input reducer with added base; “worm over” mounting position*



*Shaft-input reducer in vertical position, deep NEMA C flange, plus “J style” base*



*Vertical output shaft, extended-height base, solid input shaft with no mounting flange*



*Quill-input reducer with output flange added*

*Basic worm gear reducers can be easily modified with mounting accessories to meet application needs. Four examples are shown.*

Reducers having hollow output shafts are usually shaft-mounted to the driven load. If no output flange or secondary base is used, a reaction arm prevents the reducer housing from rotating.



*Hollow output shaft reducer with reaction arm mounted. This model also has quill input and shallow NEMA C input flange.*

Do not mount reducers with the input shaft facing down. Other than that, they may generally be mounted in any orientation. If the reducer is vented, be sure the vent plug is moved to a location as close as possible to the top of the unit, as shown in the examples below.

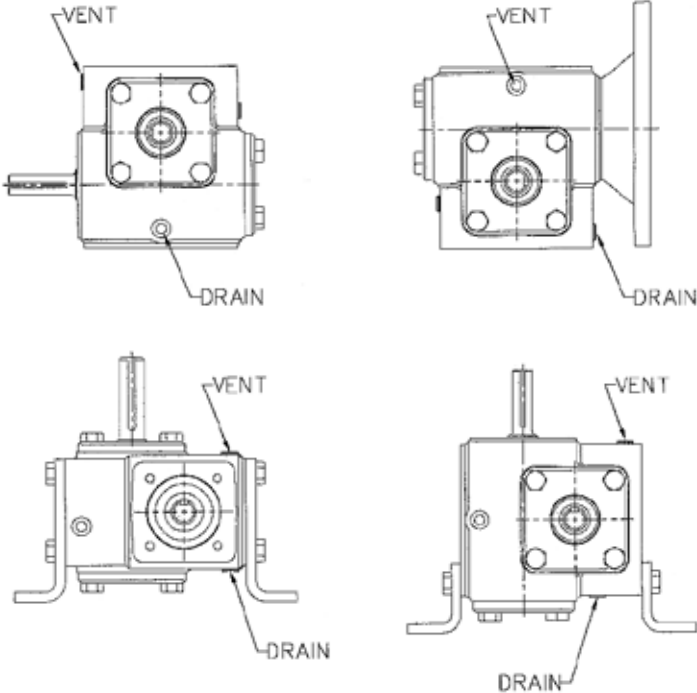

**Output Speed and Torque:** These are the key criteria for matching a gear reducer to the application needs.

**Center Distance:** The basic measurement or size reference for worm gear reducers. Generally, the larger the center distance, the greater the reducer capacity. Center distance is measured from the centerline of the input shaft to the centerline of the output shaft.

**Horsepower:** A reducer's input horsepower rating represents the maximum prime mover size the reducer is designed to handle. Output horsepower, while usually listed by reducer manufacturers, has little application relevance. Speed and torque are the real considerations.

**Overhung Load:** This is a force applied at right angles to a shaft beyond the shaft's outermost bearing. Too much overhung load can cause bearing or shaft failure. Unless otherwise stated, a reducer manufacturer's overhung load maximums are rated with no shaft attachments such as sheaves or sprockets. The American Gear Manufacturers Association provides factors, commonly called "K" factors, for various shaft attachments by which the manufacturer's maximum should be reduced. Overhung load can be eased by locating a sheave or sprocket as close to the reducer bearing as possible. In cases of extreme overhung load, an additional outboard bearing may be required.

The following formula can be used to calculate overhung load (OHL):

$$\text{OHL (pounds)} = \frac{\text{Torque (inch-pounds)} \times K \text{ (load factor constant of overhung load)}}{R \text{ (radius of pulley, sprocket or gear)}}$$

where, K equals 1.00 for chain and sprocket, 1.25 for a gear, and 1.5 for a pulley and v-belt.

**Thrust Load:** This is a force applied parallel to a shaft's axis. Mixers, fans and blowers are among driven machines that can induce thrust loads. Exceeding manufacturers' maximums for thrust loading can cause premature shaft and bearing failure.

**Mechanical and Thermal Ratings:** Mechanical ratings refer to the maximum power a reducer can transmit based on the strength of its components. Many industrial reducers, including Marathon Motors, provide a 200% safety margin over this rating for start-ups and momentary overloads.

Thermal rating refers to the power a reducer can transmit continuously based on its ability to dissipate the heat caused by operating friction.

In practice, the mass of a cast iron reducer housing and its oil lubrication system provide sufficient heat dissipation so that mechanical and thermal ratings are essentially equal. Aluminum-housed or grease-lubricated reducers have less heat dissipation mass and therefore require consideration of thermal rating.

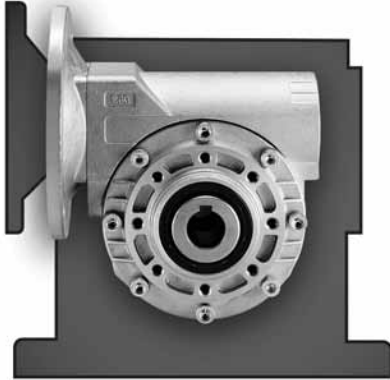

*Graphic shows compact size of an aluminum-housed worm gear reducer compared with a cast iron housed reducer of the same center distance. Smaller size and lighter weight can be an application advantage in many cases, but reduced mass means that the reducer's thermal rating must be carefully considered.*

**Service Factor:** Established by the American Gear Manufacturers Association (AGMA), gearing service factors are a means to adjust a reducer's ratings relative to an application's load characteristics. Proper determination of an application's service factor is critical to maximum reducer life and trouble-free service. Unless otherwise designated, assume a manufacturer's ratings are based on an AGMA-defined service factor of 1.0, meaning continuous operation for 10 hours per day or less with no recurring shock loads. If conditions differ from this, input horsepower and torque ratings must be multiplied by the service factor selected from one of the tables below. In addition, AGMA has standardized service factor data for a wide variety of specific applications. Contact your manufacturer for this information.

**Input Speed:** Gear reducers are best driven at input speeds common in industrial electric motors, typically 1200, 1800 or 2500 RPM. This provides sufficient "splash" for the reducer's lubrication system, but not so much as to cause oil "churning." For input speeds under 900 RPM or above 3000 RPM, consult the manufacturer. Alternative lubricants may be suggested.

## Service Factor Conversions for Reducers With Electric or Hydraulic Motor Input

Duration of Service (Hours per day)	Uniform Load	Moderate Shock	Heavy Shock	Extreme Shock
Occasional 1/2 Hour	--*	--*	1.0	1.25
Less than 3 Hours	1.0	1.0	1.25	1.50
3 - 10 Hours	1.0	1.25	1.50	1.75
Over 10 Hours	1.25	1.50	1.75	2.00

\* Unspecified service factors should be 1.00 or as agreed upon by the user and manufacturer.

## Service Factor Conversions for Reducers With Engine Input

Hydraulic or Electric Motor	Single Cylinder Engines	Multi-Cylinder Engines
1.00	1.50	1.25
1.25	1.75	1.50
1.50	2.00	1.75
1.75	2.25	2.00
2.00	2.50	2.25

## Special Environmental Considerations

---

Gear reducers are extremely rugged pieces of equipment with long life in most types of power transmission applications. Modern components, including seals and synthetic lubricants, are designed for sustained high-temperature operation. Extreme heat, however, can be a problem. As a rule of thumb, maximum oil sump temperature for a speed reducer is 200°F, or 100°F above ambient temperature, whichever is lower. Exceeding these guidelines can shorten the reducer's life. Be sure to provide adequate air space around a reducer for heat dissipation. In some cases, it may be necessary to provide an external cooling fan. In a gearmotor application, the fan on a totally enclosed, fan cooled motor can also aid in cooling the reducer.

Moisture or high humidity is another concern. A key instance of this is a food processing environment requiring washdowns. In such cases, consider reducers with special epoxy coatings, external shaft seals, and stainless steel shaft extensions and hardware. If a gearmotor is used, be sure the motor has similar washdown-duty features.

## **Gear Reducer Maintenance**

---

Industrial gear reducers require very little maintenance, especially if they have been factory-filled with quality, synthetic lubricant to a level sufficient for all mounting positions. In most cases, oil change will not be necessary over the life of the reducer. It is recommended that oil be changed only if repair or maintenance needs otherwise dictate gearbox disassembly.

Oil level should, however, be checked periodically and vent plugs inspected to ensure they are clean and operating.

Otherwise, general maintenance procedures for any industrial equipment apply. This includes making sure mounting bolts and other attachments are secure and that no other unusual conditions have occurred.

# CHAPTER X

## Adjustable Speed Drives

By definition, adjustable speed drives of any type provide a means of variably changing speed to better match operating requirements. Such drives are available in mechanical, fluid and electrical types.

The most common mechanical versions use combinations of belts and sheaves, or chains and sprockets, to adjust speed in set, selectable ratios – 2:1, 4:1, 8:1 and so forth. Traction drives, a more sophisticated mechanical control scheme, allow incremental speed adjustments. Here, output speed is varied by changing the contact points between metallic disks, or between balls and cones.

Adjustable speed fluid drives provide smooth, stepless adjustable speed control. There are three major types. Hydrostatic drives use electric motors or internal combustion engines as prime movers in combination with hydraulic pumps, which in turn drive hydraulic motors. Hydrokinetic and hydroviscous drives directly couple input and output shafts. Hydrokinetic versions adjust speed by varying the amount of fluid in a vortex that serves as the input-to-output coupler. Hydroviscous drives, also called oil shear drives, adjust speed by controlling oil-film thickness, and therefore slippage, between rotating metallic disks.

An eddy current drive, while technically an electrical drive, nevertheless functions much like a hydrokinetic or hydroviscous fluid drive in that it serves as a coupler between a prime mover and driven load. In an eddy current drive, the coupling consists of a primary magnetic field and secondary fields created by induced eddy currents. The amount of magnetic slippage allowed among the fields controls the driving speed.

In most industrial applications, mechanical, fluid or eddy current drives are paired with constant-speed electric motors. On the other hand, solid state electrical drives (also termed electronic drives), create adjustable speed motors, allowing speeds from zero RPM to beyond the motor's base speed. Controlling the speed of the motor has several benefits, including increased energy efficiency by eliminating energy losses in mechanical speed changing devices. In addition, by reducing, or often eliminating, the need for wear-prone mechanical components, electrical drives foster increased overall system reliability, as well as lower maintenance costs. For these and other reasons, electrical drives are the fastest growing type of adjustable speed drive.

There are two basic drive types related to the type of motor controlled – DC and AC. A DC direct current drive controls the speed of a DC motor by varying the armature voltage (and sometimes also the field voltage). An alternating current drive controls the speed of an AC motor by varying the frequency and voltage supplied to the motor.

## DC Drives

---

Direct current drives are easy to apply and technologically straightforward. They work by rectifying AC voltage from the power line to DC voltage, then feeding adjustable voltage to a DC motor. With permanent magnet DC motors, only the armature voltage is controlled. The more voltage supplied, the faster the armature turns. With wound-field motors, voltage must be supplied to both the armature and the field. In industry, the following three types of DC drives are most common:



*A general-purpose DC SCR drives family. From left, NEMA 4/12 "totally enclosed" version, chassis-mount, NEMA 1 "open" enclosure.*

**DC SCR Drives:** These are named for the silicon controlled rectifiers (also called thyristors) used to convert AC to controlled voltage DC. Inexpensive and easy to use, these drives come in a variety of enclosures, and in unidirectional or reversing styles.

**Regenerative SCR Drives:** Also called four quadrant drives, these allow the DC motor to provide both motoring and braking torque. Power coming back from the motor during braking is regenerated back to the power line and not lost.

**Pulse Width Modulated DC Drives:** Abbreviated PWM and also called, generically, transistorized DC drives, these provide smoother speed control with higher efficiency and less motor heating. Unlike SCR drives,

PWM types have three elements. The first converts AC to DC, the second filters and regulates the fixed DC voltage, and the third controls average voltage by creating a stream of variable width DC pulses. The filtering section and higher level of control modulation account for the PWM drive's improved performance compared with a common SCR drive.

## AC Drives

---

AC drive operation begins in much the same fashion as a DC drive. Alternating line voltage is first rectified to produce DC. But because an AC motor is used, this DC voltage must be changed back, or inverted, to an adjustable-frequency alternating voltage. The drive's inverter section accomplishes this. In years past, this was accomplished using SCRs. However, modern AC drives use a series of transistors to invert DC to adjustable-frequency AC.



*With advances in power electronics, even so-called "micro" drives can be used with motors 40 HP or higher. Full-featured unit shown includes keypad programming and alphanumeric display.*

This synthesized alternating current is then fed to the AC motor at the frequency and voltage required to produce the desired motor speed. For example, a 60 hz synthesized frequency, the same as standard line frequency in the United States, produces 100% of rated motor speed. A lower frequency produces a lower speed, and a higher frequency a higher speed. In this way, an AC drive can produce motor speeds from, approximately, 15 to 200% of a motor's normally rated RPM – by delivering frequencies of 9 hz to 120 hz, respectively.

Today, AC drives are becoming the systems of choice in many industries. Their use of simple and rugged three-phase induction motors means that AC drive systems are the most reliable and least maintenance prone of all. Plus, microprocessor advancements have enabled the creation of so-called vector drives, which provide greatly enhance response, operation down to zero speed and positioning accuracy. Vector drives, especially when

combined with feedback devices such as tachometers, encoders and resolvers in a closed-loop system, are continuing to replace DC drives in demanding applications.



*“Sub-micro” drives provide a wide array of features in a very small package.*

By far the most popular AC drive today is the pulse width modulated type. Though originally developed for smaller-horsepower applications, PWM is now used in drives of hundreds or even thousands of horsepower – as well as remaining the staple technology in the vast majority of small integral and fractional horsepower “micro” and “sub-micro” AC drives.

Pulse width modulated refers to the inverter’s ability to vary the output voltage to the motor by altering the width and polarity of voltage pulses. The voltage and frequency are synthesized using this stream of voltage pulses. This is accomplished through microprocessor commands to a series of power semiconductors that serve as on-off switches. Today, these switches are usually IGBTs, or isolated gate bipolar transistors. A big advantage to these devices is their fast switching speed resulting in higher pulse or carrier frequency, which minimizes motor noise.

## **“One Piece” Motor/Drive Combinations**

---

Variouly called intelligent motors, smart motors or integrated motors and drives, these units combine a three-phase electric motor and a pulse width modulated inverter drive in a single package. Some designs mount the drive components in what looks like an oversize conduit box. Other designs integrate the drive into a special housing made to blend with the motor. A supplementary cooling fan is also frequently used for the drive electronics to counteract the rise in ambient temperature caused by being in close proximity to an operating motor. Some designs also encapsulate the inverter boards to guard against damage from vibration.

Size constraints limit integrated drive and motor packages to the smaller horsepower ranges and require programming by remote keypad, either hand-held or panel mounted. Major advantages are compactness and elimination of additional wiring.



*One-piece motor and drive combinations can be a pre-packaged solution in some applications. Unit shown incorporates drive electronics and cooling system in a special housing at the end of the motor.*

## AC Drive Application Factors

---

As PWM AC drives have continued to increase in popularity, drives manufacturers have spent considerable research and development effort to build in programmable acceleration and deceleration ramps, a variety of speed presets, diagnostic abilities, and other software features. Operator interfaces have also been improved with some drives incorporating “plain-English” readouts to aid set-up and operation. Plus, an array of input and output connections, plug-in programming modules, and off-line programming tools allow multiple drive set-ups to be installed and maintained in a fraction of the time spent previously. All these features have simplified drive applications. However, several basic points must be considered:

**Torque:** This is the most critical application factor. All torque requirements must be assessed, including starting, running, accelerating and decelerating and, if required, holding torque. These values will help determine what current capacity the drive must have in order for the motor to provide the torque required. Usually, the main constraint is starting torque, which relates to the drive’s current overload capacity. (Many drives also provide a starting torque boost by increasing voltage at lower frequencies.)

Perhaps the overriding question, however, is whether the application is variable torque or constant torque. Most variable torque applications fall into one of two categories – air moving or liquid moving – and involve centrifugal pumps and fans. The torque required in these

applications decreases as the motor RPM decreases. Therefore, drives for variable torque loads require little overload capacity. Constant torque applications, including conveyors, positive displacement pumps, extruders, mixers or other “machinery” require the same torque regardless of operating speed, plus extra torque to get started. Here, high overload capacity is required.

Smaller-horsepower drives are often built to handle either application. Typically, only a programming change is required to optimize efficiency (variable volts-to-hertz ratio for variable torque loads, constant volts-to-hertz ratio for constant torque loads). Larger horsepower drives are usually built specifically for either variable or constant torque applications.

**Speed:** As mentioned, AC drives provide an extremely wide speed range. In addition, they can provide multiple means to control this speed. Many drives, for example, include a wide selection of preset speeds, which can make set-up easier. Similarly, a range of acceleration and deceleration speed “ramps” are provided. Slip compensation, which maintains constant speed with a changing load, is another feature that can be helpful. In addition, many drives have programmable “skip frequencies.” Particularly with fans or pumps, there may be specific speeds at which vibration takes place. By programming the drive to avoid these corresponding frequencies, the vibration can be minimized. Another control function, common with fans, is the ability for the drive to start into a load already in motion – often called a rolling start or spinning start. If required, be sure your drive allows this or you will face overcurrent tripping.

**Current:** The current a motor requires to provide needed torque (see previous discussion of torque) is the basis for sizing a drive. Horsepower ratings, while listed by drives manufacturers as a guide to the maximum motor size under most applications, are less precise. Especially for demanding constant torque applications, the appropriate drive may, in fact, be “oversized” relative to the motor. As a rule, general-purpose constant torque drives have an overload current capacity of approximately 150% for one minute, based on nominal output. If an application exceeds these limits, a larger drive should be specified.

**Power Supply:** Drives tolerate line-voltage fluctuations of 10-15% before tripping and are sensitive to power interruptions. Some drives have “ride-through” capacity of only a second or two before a fault is triggered, shutting down the drive. Drives are sometimes programmed for multiple automatic restart attempts. For safety, plant personnel must be aware of this. Manual restart may be preferred.

Most drives require three-phase input. Smaller drives may be available for single-phase input. In either case, the motor itself must be three-phase.

Drives, like any power conversion device, create certain power disturbances (called “noise” or “harmonic distortion”) that are reflected back into the power system to which they are connected. These disturbances rarely affect the drive itself but can affect other electrically sensitive components.

**Control Complexity:** Even small, low-cost AC drives are now being produced with impressive features, including an array of programmable functions and extensive input and output capability for integration with other components and control systems. Additional features may be offered as options. Vector drives, as indicated previously, are one example of enhanced control capability for specialized applications.

In addition, nearly all drives provide some measure of fault logging and diagnostic capability. Some are extensive, and the easiest to use display the information in words and phrases rather than simply numerical codes.

**Environmental Factors:** The enemies of electronic components are well-known. Heat, moisture, vibration and dirt are chief among them and obviously should be mitigated. Drives are rated for operation in specific maximum and minimum ambient temperatures. If the maximum ambient is exceeded, extra cooling must be provided, or the drive may have to be oversized. High altitudes, where thinner air limits cooling effectiveness, call for special consideration. Ambient temperatures too low can allow condensation. In these cases, or where humidity is generally high, a space heater may be needed.

Drive enclosures should be selected based on environment. NEMA 1 enclosures are ventilated and must be given room to “breathe.” NEMA 4/12 enclosures, having no ventilation slots, are intended to keep dirt out and are also used in washdown areas. Larger heat sinks provide convection cooling and must not be obstructed, nor allowed to become covered with dirt or dust. Higher-horsepower drives are typically supplied within NEMA-rated enclosures. “Sub-micro” drives, in particular, often require a customer-supplied enclosure in order to meet NEMA and National Electrical Code standards. The enclosures of some “micro” drives, especially those cased in plastic, may also not be NEMA-rated.

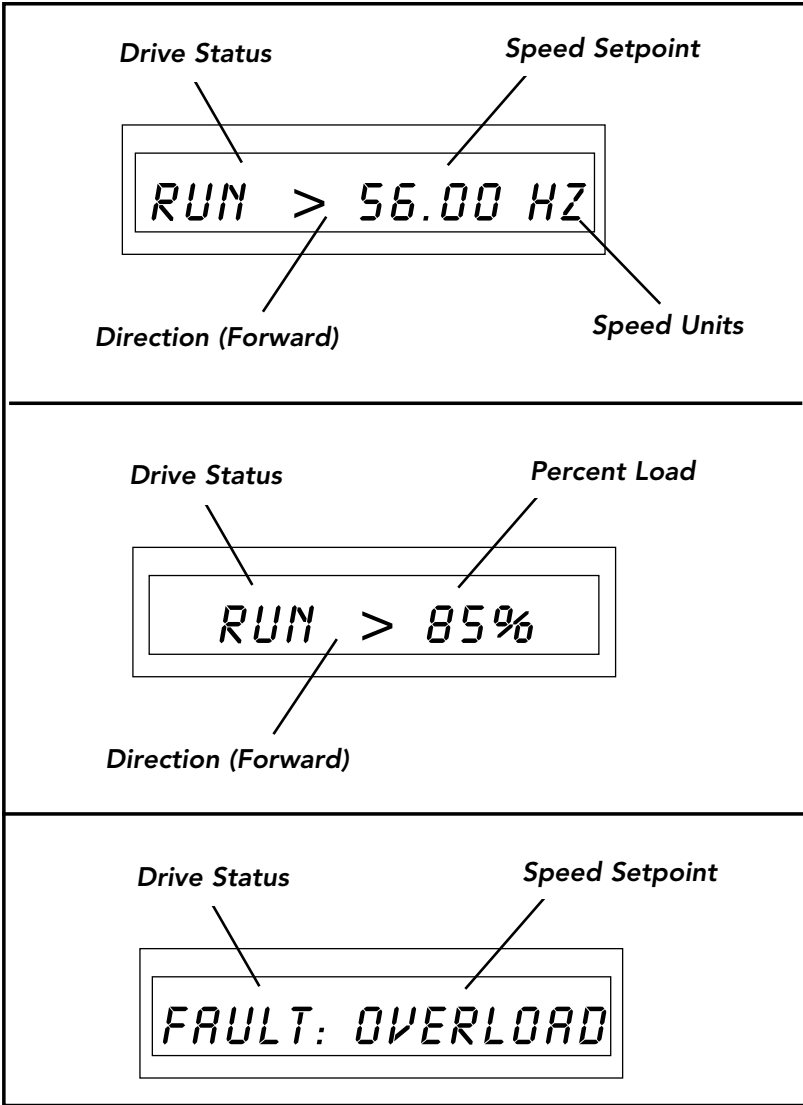

Examples of operating and diagnostic displays in a modern AC drive.

## Motor Considerations With AC Drives

---

One drawback to pulse width modulated drives is their tendency to produce voltage spikes, which in some instances can damage the insulation systems used in electric motors. This tendency is increased in applications with long cable distances (more than 50 feet) between the motor and drive and with higher-voltage drives. In the worst cases, the spikes can literally “poke a hole” into the insulation, particularly that used in the motor’s windings. To guard against insulation damage, some manufacturers now offer inverter-duty motors having special insulation systems that resist voltage spike damage. For example, Marathon Motors’s system, used in all three-phase motors 1 HP and larger, is called MAX GUARD® (Inverter Rated Insulation System).

Particularly with larger drives, it may be advisable to install line reactors between the motor and drive to choke off the voltage spikes. In addition, some increased motor heating will inevitably occur because of the inverter’s “synthesized” AC wave form. Insulation systems on industrial motors built in recent years, and especially inverter-duty motors, can tolerate this except in the most extreme instances. A greater cooling concern involves operating for an extended time at low motor RPM, which reduces the flow of cooling air and especially in constant torque applications where the motor is heavily loaded even at low speeds. Here, secondary cooling such as a special blower may be required.



*Constant-speed blower kits can be added in the field, providing additional cooling to motors operated at low RPM as part of an adjustable speed drive system.*

## **Routine Maintenance of Electrical Drives**

---

Major maintenance, troubleshooting and repair of drives should be left to a qualified technician, following the drive manufacturer's recommendations. However, routine maintenance can help prevent problems. Here are some tips:

- Periodically check the drive for loose connections or any other unusual physical conditions such as corrosion.
- Vacuum or brush heatsink areas regularly.
- If the drive's enclosure is NEMA 1, be sure vent slots are clear of dust or debris.
- If the drive is mounted within a secondary enclosure, again be sure vent openings area clear and that any ventilation fans are operating properly.
- Unless it is otherwise necessary for major maintenance or repair, the drive enclosure should not be opened.

# CHAPTER XI

## Engineering Data

### Temperature Conversion Table

Locate known temperature in °C/°F column.  
Read converted temperature in °C/°F column.

°C	°C/°F	°F	°C	°C/°F	°F	°C	°C/°F	°F
-45.4	-50	-58	15.5	60	140	76.5	170	338
-42.7	-45	-49	18.3	65	149	79.3	175	347
-40	-40	-40	21.1	70	158	82.1	180	356
-37.2	-35	-31	23.9	75	167	85	185	365
-34.4	-30	-22	26.6	80	176	87.6	190	374
-32.2	-25	-13	29.4	85	185	90.4	195	383
-29.4	-20	-4	32.2	90	194	93.2	200	392
-26.6	-15	5	35	95	203	96	205	401
-23.8	-10	14	37.8	100	212	98.8	210	410
-20.5	-5	23	40.5	105	221	101.6	215	419
-17.8	0	32	43.4	110	230	104.4	220	428
-15	5	41	46.1	115	239	107.2	225	437
-12.2	10	50	48.9	120	248	110	230	446
-9.4	15	59	51.6	125	257	112.8	235	455
-6.7	20	68	54.4	130	266	115.6	240	464
-3.9	25	77	57.1	135	275	118.2	245	473
-1.1	30	86	60	140	284	120.9	250	482
1.7	35	95	62.7	145	293	123.7	255	491
4.4	40	104	65.5	150	302	126.5	260	500
7.2	45	113	68.3	155	311	129.3	265	509
10	50	122	71	160	320	132.2	270	518
12.8	55	131	73.8	165	329	136	275	527

$$^{\circ}\text{F} = (9/5 \times ^{\circ}\text{C}) + 32$$

$$^{\circ}\text{C} = 5/9 (^{\circ}\text{F} - 32)$$

## Mechanical Characteristics

To Find:	Use:
Torque in Inch-Pounds	$\frac{\text{HP} \times 63,025}{\text{RPM}}$
Horsepower	$\frac{\text{Torque (lb. in.)} \times \text{RPM}}{63,025}$
RPM	$\frac{120 \times \text{Frequency}}{\text{Number of Poles}}$

## Converting Torque Units Inch-Pounds and Newton Meters

$\text{Torque (lb. in.)} = 8.85 \times \text{Nm}$ <p style="text-align: center;">or</p> $= 88.5 \times \text{daNm}$
$\text{Torque (Nm)} = \frac{\text{lb. in.}}{8.85}$
$\text{Torque (daNm)} = \frac{\text{lb. in.}}{88.5}$

## Electrical Characteristics

To Find:	Use: Single Phase	Or: Three Phase
Amperes Knowing HP	$\frac{\text{HP} \times 746}{\text{E} \times \text{Eff} \times \text{PF}}$	$\frac{\text{HP} \times 746}{1.73 \times \text{E} \times \text{Eff} \times \text{PF}}$
Amperes Knowing kW	$\frac{\text{kW} \times 1000}{\text{E} \times \text{PF}}$	$\frac{\text{kW} \times 1000}{1.73 \times \text{E} \times \text{PF}}$
Amperes Knowing kVA	$\frac{\text{kVA} \times 1000}{\text{E}}$	$\frac{\text{kVA} \times 1000}{1.73 \times \text{E}}$
Kilowatts	$\frac{\text{I} \times \text{E} \times \text{PF}}{1000}$	$\frac{1.73 \times \text{I} \times \text{E} \times \text{PF}}{1000}$
kVA	$\frac{\text{I} \times \text{E}}{1000}$	$\frac{1.73 \times \text{I} \times \text{E}}{1000}$
HP (output)	$\frac{\text{I} \times \text{E} \times \text{Eff} \times \text{PF}}{746}$	$\frac{1.73 \times \text{I} \times \text{E} \times \text{Eff} \times \text{PF}}{746}$

I = amperes

Eff = efficiency

PF = power factor

RPM = revolutions per minute

E = volts

kW - kilowatts

HP = horsepower

kVA = kilovolt amperes

# Fractional/Decimal/Millimeter Conversion

Fraction	Decimal	Millimeter	Fraction	Decimal	Millimeter	MM	Inch
1/64	- .015625	- 0.397	33/64	- .515625	- 13.097	1	- .039
1/32	- .03125	- 0.794	17/32	- .53125	- 13.494	2	- .0790
3/64	- .046875	- 1.191	35/64	- .546875	- 13.891	3	- .1181
1/16	- .0625	- 1.588	9/16	- .5625	- 14.288	4	- .1575
5/64	- .078125	- 1.984	37/64	- .578125	- 14.684	5	- .1969
3/32	- .09375	- 2.381	19/32	- .59375	- 15.081	6	- .2362
7/64	- .109375	- 2.778	39/64	- .609375	- 15.478	7	- .2756
1/8	- .125	- 3.175	5/8	- .625	- 15.875	8	- .3150
9/64	- .140625	- 3.572	41/64	- .640625	- 16.272	9	- .3543
5/32	- .15625	- 3.969	21/32	- .65625	- 16.669	10	- .3937
11/64	- .171875	- 4.366	43/64	- .671875	- 17.066	11	- .4331
3/16	- .1875	- 4.762	11/16	- .6875	- 17.462	12	- .4724
13/64	- .203125	- 5.129	45/64	- .703125	- 17.859	13	- .5119
7/32	- .21875	- 5.556	23/32	- .71875	- 18.256	14	- .5519
15/64	- .234375	- 5.953	47/64	- .734375	- 18.653	15	- .5906
1/4	- .25	- 6.350	3/4	- .75	- 19.050	16	- .6300
17/64	- .265625	- 6.747	49/64	- .765625	- 19.447	17	- .6693
9/32	- .28125	- 7.144	25/32	- .78125	- 19.844	18	- .7087
19/64	- .296875	- 7.541	51/64	- .796875	- 20.241	19	- .7480
5/16	- .3125	- 7.938	13/16	- .8125	- 20.638	20	- .7874
21/64	- .328125	- 8.334	53/64	- .828125	- 21.034	21	- .8268
11/32	- .34375	- 8.731	27/32	- .84375	- 21.431	22	- .8661
23/64	- .359375	- 9.128	55/64	- .859375	- 21.828	23	- .9055
3/8	- .375	- 9.525	7/8	- .875	- 22.225	24	- .9449
25/64	- .390625	- 9.921	57/64	- .890625	- 22.622	25	- .9843
13/32	- .40625	- 10.319	29/32	- .90625	- 23.019		
27/64	- .421875	- 10.716	59/64	- .921875	- 23.416		
7/16	- .4375	- 11.112	15/16	- .9375	- 23.812		
29/64	- .453125	- 11.509	61/64	- .953125	- 24.209		
15/32	- .46875	- 11.906	31/32	- .96875	- 24.606		
31/64	- .484375	- 12.303	63/64	- .984375	- 25.003		
1/2	- .5	- .12.700	1	- 1.	- 25.400		
To convert millimeters to inches, multiply by .03937							
To convert inches to millimeters, multiply by 25.40							

# CHAPTER XII

## Glossary

**Actuator:** A device that creates mechanical motion by converting various forms of energy to rotating or linear mechanical energy.

**Adjustable Speed Drive:** A mechanical, fluid or electrical device that variably changes an input speed to an output speed matching operating requirements.

**AGMA (American Gear Manufacturers Association):** Standards setting organization composed of gear products manufacturers and users. AGMA standards help bring uniformity to the design and application of gear products.

**Air-Over (AO):** Motors for fan or blower service that are cooled by the air stream from the fan or blower.

**Alternating Current (AC):** The standard power supply available from electric utilities.

**Ambient Temperature:** The temperature of the air which, when coming into contact with the heated parts of a motor, carries off its heat. Ambient temperature is commonly known as room temperature.

**Ampere (Amp):** The standard unit of electric current. The current produced by a pressure of one volt in a circuit having a resistance of one ohm.

**Armature:**

- The rotating part of a brush-type direct current motor.
- In an induction motor, the squirrel cage rotor.

**Axial Movement:** Often called "endplay." The endwise movement of motor or gear shafts. Usually expressed in thousandths of an inch.

**Back Driving:** Driving the output shaft of a gear reducer – using it to increase speed rather than reduce speed. Worm gear reducers are not suitable for service as speed increasers.

**Backlash:** Rotational movement of a gear reducer's output shaft clockwise and counter clockwise, while holding the input shaft stationary. Usually expressed in thousandths of an inch and measure at a specific radius at the output shaft.

**Bearings:**

*Sleeve:* Common in home-appliance motors.

*Ball:* Used when high shaft load capacity is required. Ball bearings are usually used in industrial and agricultural motors.

*Roller:* Use on output shafts of heavy-duty gear reducers and on some high-horsepower motors for maximum overhung and thrust load capacities.

**Breakdown Torque:** The maximum torque a motor can achieve with rated voltage applied at rated frequency, without a sudden drop in speed or stalling.

**Brush:** Current-conducting material in a DC motor, usually graphite, or a combination of graphite and other materials. The brush rides on the commutator of a motor and forms an electrical connection between the armature and the power source.

**Canadian Standards Association (CSA):** The agency that sets safety standards for motors and other electrical equipment used in Canada.

**Capacitance:** As the measure of electrical storage potential of a capacitor, the unit of capacitance is the farad, but typical values are expressed in microfarads.

**Capacitor:** A device that stores electrical energy. Used on single-phase motors, a capacitor can provide a starting "boost" or allow lower current during operation.

**Center Distance:** A basic measurement or size reference for worm gear reducers, measured from the centerline of the worm to the centerline of the worm wheel.

**Centrifugal Starting Switch:** A mechanism that disconnects the starting circuit of a motor when the rotor reaches approximately 75% of operating speed.

**Cogging:** Non-uniform or erratic rotation of a direct current motor. It usually occurs at low speeds and may be a function of the adjustable speed control or of the motor design.

**Commutator:** The part of a DC motor armature that causes the electrical current to be switched to various armature windings. Properly sequenced switching creates the motor torque. The commutator also provides the means to transmit electrical current to the moving armature through brushes that ride on the commutator.

**Counter Electromotive Force:** Voltage that opposes line voltage caused by induced magnetic field in a motor armature or rotor.

**Current, AC:** The power supply usually available from the electric utility company or alternators.

**Current, DC:** The power supply available from batteries, generators (not alternators), or a rectified source used for special applications.

**Duty Cycle:** The relationship between the operating time and the resting time of an electric motor. Motor ratings according to duty are:

- *Continuous duty*, the operation of loads for over one hour.
- *Intermittent duty*, the operation during alternate periods of load and rest. Intermittent duty is usually expressed as 5 minutes, 30 minutes or one hour.

**Efficiency:** A ratio of the input power compared to the output, usually expressed as a percentage.

**Enclosure:** The term used to describe the motor housing. The most common industrial types are: Open Drip Proof (ODP), Totally Enclosed Fan Cooled (TEFC), Totally Enclosed Non-Ventilated (TENV), Totally Enclosed Air Over (TEAO). (See Chapter IV for additional information).

**Endshield:** The part of a motor that houses the bearing supporting the rotor and acts as a protective guard to the internal parts of the motor; sometimes called endbell, endplate or end bracket.

**Excitation:** The act of creating magnetic lines of force from a motor winding by applying voltage.

**Explosion-Proof Motors:** These motors meet Underwriters Laboratories and Canadian Standards Association standards for use in hazardous (explosive) locations, as indicated by the UL label affixed to the motor. Locations are considered hazardous because the atmosphere does or may contain gas, vapor, or dust in explosive quantities.

**Field:** The stationary part of a DC motor, commonly consisting of permanent magnets. Sometimes used also to describe the stator of an AC motor.

**Flanged Reducer:** Usually used to refer to a gear reducer having provisions for close coupling of a motor either via a hollow (quill) shaft or flexible coupling. Most often a NEMA C face motor is used.

**Foot-Pound:** Energy required to raise a one-pound weight against the force of gravity the distance of one foot. A measure of torque. Inch-pound is also commonly used on smaller motors and gear reducers. An inch-pound represents the energy needed to lift one pound one inch; an inch-ounce represents the energy needed to lift one ounce one inch.

**Form Factor:** Indicates how much AC component is present in the DC output from a rectified AC supply. Unfiltered SCR (thyristor) drives have a form factor (FF) of 1.40. Pure DC, as from a battery, has a form factor of 1.0. Filtered thyristor and pulse width modulated drives often have a form factor of 1.05.

**Frame:** Standardized motor mounting and shaft dimensions as established by NEMA or IEC.

**Frequency:** Alternating electric current frequency is an expression of how often a complete cycle occurs. Cycles per second describe how many complete cycles occur in a given time increment. Hertz (hz) has been adopted to describe cycles per second so that time as well as number of cycles is specified. The standard power supply in North America is 60 hz. Most of the rest of the world has 50 hz power.

**Full Load Amperes (FLA):** Line current (amperage) drawn by a motor when operating at rated load and voltage on motor nameplate. Important for proper wire size selection, and motor starter or drive selection. Also called full load current.

**Full Load Torque:** The torque a motor produces at its rated horsepower and full-load speed.

**Fuse:** A piece of metal, connected in the circuit to be protected, that melts and interrupts the circuit when excess current flows.

**Generator:** Any machine that converts mechanical energy into electrical energy.

**Grounded Circuit:**

- An electrical circuit coupled to earth ground to establish a reference point.
- A malfunction caused by insulation breakdown, allowing current flow to ground rather than through the intended circuit.

**Hertz:** Frequency, in cycles per second, of AC power; usually 60 hz in North America, 50 hz in the rest of the world. Named after H. R. Hertz, the German scientist who discovered electrical oscillations.

**High Voltage Test:** Application of a voltage greater than the working voltage to test the adequacy of motor insulation; often referred to as high potential test or "hi-pot."

**Horsepower:** A measure of the rate of work. 33,000 pounds lifted one foot in one minute, or 550 pounds lifted one foot in one second. Exactly 746 watts of electrical power equals one horsepower. Torque and RPM may be used in relating to the horsepower of a motor. For fractional horsepower motors, the following formula may be used.

$$\text{HP} = \frac{T (\text{in.-oz}) \times 9.917 \times N \times 10^7}{33,000}$$

where,

$$\text{HP} = \text{horsepower}$$
$$T = \text{Torque}$$
$$N = \text{revolutions per minute}$$

**Hysteresis:** The lagging of magnetism in a magnetic metal, behind the magnetizing flux which produces it.

**IEC (International Electrotechnical Commission):** The worldwide organization that promotes international unification of standards or norms. Its formal decisions on technical matters express, as nearly as possible, an international consensus.

**IGBT:** Stands for isolated gate bipolar transistor. The most common and fastest-acting semiconductor switch used in pulse width modulated (PWM) AC drives.

**Impedance:** The total opposition in an electric circuit to the flow of an alternating current. Expressed in ohms.

**Induction Motor:** The simplest and most rugged electric motor, it consists of a wound stator and a rotor assembly. The AC induction motor is named because the electric current flowing in its secondary member (the rotor) is induced by the alternating current flowing in its primary member (the stator). The power supply is connected only to the stator. The combined electromagnetic effects of the two currents produce the force to create rotation.

**Insulation:** In motors, classified by maximum allowable operating temperature. NEMA classifications include: Class A = 105°C, Class B = 130°C, Class F = 155°C and Class H = 180°C.

**Input Horsepower:** The power applied to the input shaft of a gear reducer. The input horsepower rating of a reducer is the maximum horsepower the reducer can safely handle.

**Integral Horsepower Motor:** A motor rated one horsepower or larger at 1800 RPM. By NEMA definitions, this is any motor having a three digit frame number, for example, 143T.

**Inverter:** An electronic device that changes direct current to alternating current; in common usage, an AC drive.

**Kilowatt:** A unit of power equal to 1000 watts and approximately equal to 1.34 horsepower.

**Load:** The work required of a motor to drive attached equipment. Expressed in horsepower or torque at a certain motor speed.

**Locked Rotor Current:** Measured current with the rotor locked and with rated voltage and frequency applied to the motor.

**Locked Rotor Torque:** Measured torque with the rotor locked and with rated voltage and frequency applied to the motor.

**Magnetic Polarity:** Distinguishes the location of north and south poles of a magnet. Magnetic lines of force emanate from the north pole of a magnet and terminate at the south pole.

**Mechanical Rating:** The maximum power or torque a gear reducer can transmit. Many industrial reducers have a safety margin equal to 200% or more of their mechanical rating, allowing momentary overloads during start-up or other transient overloads.

**Motor Types:** Classified by operating characteristics and/or type of power required. The AC induction motor is the most common. There are several kinds of AC (alternating current) induction motors, including, for single-phase operation: shaded pole, permanent split capacitor (PSC), split phase, capacitor start/induction run and capacitor start/capacitor run. Polyphase or three-phase motors are used in larger

applications. Direct current (DC) motors are also common in industry as are gearmotors, brakemotors and other types. (See Chapter III for additional details).

**Mounting:** The most common motor mounts include: rigid base, resilient base C face or D flange, and extended through bolts. (See Chapter IV for additional details). Gear reducers are similarly base-mounted, flange-mounted, or shaft-mounted.

**National Electric Code (NEC):** A safety code regarding the use of electricity. The NEC is sponsored by the National Fire Protection Institute. It is also used by insurance inspectors and by many government bodies regulating building codes.

**NEMA (National Electrical Manufacturers Association):** A non-profit trade organization, supported by manufacturers of electrical apparatus and supplies in the United States. Its standards alleviate misunderstanding and help buyers select the proper products. NEMA standards for motors cover frame sizes and dimensions, horsepower ratings, service factors, temperature rises and various performance characteristics.

**Open Circuit:** A break in an electrical circuit that prevents normal current flow.

**Output Horsepower:** The amount of horsepower available at the output shaft of a gear reducer. Output horsepower is always less than the input horsepower due to the efficiency of the reducer.

**Output Shaft:** The shaft of a speed reducer assembly that is connected to the load. This may also be called the drive shaft or the slow speed shaft.

**Overhung Load:** A force applied at right angles to a shaft beyond the shaft's outermost bearing. This shaft-bending load must be supported by the bearing.

**Phase:** The number of individual voltages applied to an AC motor. A single-phase motor has one voltage in the shape of a sine wave applied to it. A three-phase motor has three individual voltages applied to it. The three phases are at 120 degrees with respect to each other so that peaks of voltage occur at even time intervals to balance the power received and delivered by the motor throughout its 360 degrees of rotation.

**Plugging:** A method of braking a motor that involves applying partial or full voltage in reverse to bring the motor to zero speed.

**Polarity:** As applied to electric circuits, polarity indicates which terminal is positive and which is negative. As applied to magnets, it indicates which pole is north and which pole is south.

**Poles:** Magnetic devices set up inside the motor by the placement and connection of the windings. Divide the number of poles into 7200 to determine the motor's normal speed. For example, 7200 divided by 2 poles equals 3600 RPM.

**Power Factor:** The ratio of "apparent power" (expressed in kVA) and true or "real power" (expressed in kW).

$$\text{Power Factor} = \frac{\text{Real Power}}{\text{Apparent Power}}$$

Apparent power is calculated by a formula involving the "real power," that which is supplied by the power system to actually turn the motor, and "reactive power," which is used strictly to develop a magnetic field within the motor. Electric utilities prefer power factors as close to 100% as possible, and sometimes charge penalties for power factors below 90%. Power factor is often improved or "corrected" using capacitors. Power factor does not necessarily relate to motor efficiency, but is a component of total energy consumption.

**Prime Mover:** In industry, the prime mover is most often an electric motor. Occasionally engines, hydraulic or air motors are used. Special application considerations are called for when other than an electric motor is the prime mover.

**Pull Out Torque:** Also called breakdown torque or maximum torque, this is the maximum torque a motor can deliver without stalling.

**Pull Up Torque:** The minimum torque delivered by a motor between zero and the rated RPM, equal to the maximum load a motor can accelerate to rated RPM.

**Pulse Width Modulation:** Abbreviated PWM, the most common frequency synthesizing system in AC drives; also used in some DC drives for voltage control.

**Reactance:** The opposition to a flow of current other than pure resistance. Inductive reactance is the opposition to change of current in an inductance (coil of wire). Capacitive reactance is the opposition to change of voltage in a capacitor.

**Rectifier:** A device or circuit for changing alternating current (AC) to direct current (DC).

**Regenerative Drive:** A drive that allows a motor to provide both motoring and braking torque. Most common with DC drives.

**Relay:** A device having two separate circuits, it is constructed so that a small current in one of the circuits controls a large current in the other circuit. A motor starting relay opens or closes the starting circuit under predetermined electrical conditions in the main circuit (run winding).

**Reluctance:** The characteristics of a magnetic field which resist the flow of magnetic lines of force through it.

**Resistor:** A device that resists the flow of electrical current for the purpose of operation, protection or control. There are two types of resistors - fixed and variable. A fixed resistor has a fixed value of ohms while a variable resistor is adjustable.

**Rotation:** The direction in which a shaft turns is either clockwise (CW) or counter clockwise (CCW). When specifying rotation, also state if viewed from the shaft or opposite shaft end of motor.

**Rotor:** The rotating component of an induction AC motor. It is typically constructed of a laminated, cylindrical iron core with slots for cast-aluminum conductors. Short-circuiting end rings complete the "squirrel cage," which rotates when the moving magnetic field induces a current in the shorted conductors.

**SCR Drive:** Named after the silicon controlled rectifiers that are at the heart of these controls, an SCR drive is the most common type of general-purpose drive for direct current motors.

**Self-Locking:** The inability of a gear reducer to be driven backwards by its load. Most general purpose reducers are not self-locking.

**Service Factor for Gearing:** A method of adjusting a reducer's load carrying characteristics to reflect the application's load characteristics. AGMA (American Gear Manufacturers Association) has established standardized service factor information.

**Service Factor for Motors:** A measure of the overload capacity built into a motor. A 1.15 SF means the motor can deliver 15% more than the rated horsepower without injurious overheating. A 1.0 SF motor should not be loaded beyond its rated horsepower. Service factors will vary for different horsepower motors and for different speeds.

**Short Circuit:** A fault or defect in a winding causing part of the normal electrical circuit to be bypassed, frequently resulting in overheating of the winding and burnout.

**Slip:** (1) The difference between rotating magnetic field speed (synchronous speed) and rotor speed of AC induction motors. Usually expressed as a percentage of synchronous speed. (2) The difference between the speed of the rotating magnetic field (which is always synchronous) and the rotor in a non-synchronous induction motor is known as slip and is expressed as a percentage of a synchronous speed. Slip generally increases with an increase in torque.

**Speed Regulation:** In adjustable speed drive systems, speed regulation measures the motor and control's ability to maintain a constant preset speed despite changes in load from zero to 100%. It is expressed as a percentage of the drive system's rated full load speed.

**Stator:** The fixed part of an AC motor, consisting of copper windings within steel laminations.

**Temperature Rise:** The amount by which a motor, operating under rated conditions, is hotter than its surrounding ambient temperature.

**Temperature Tests:** These determine the temperature of certain parts of a motor, above the ambient temperature, while operating under specific environmental conditions.

**Thermal Protector:** A device, sensitive to current and heat, which protects the motor against overheating due to overload or failure to start. Basic types include automatic reset, manual reset and resistance temperature detectors.

**Thermal Rating:** The power or torque a gear reducer can transmit continuously. This rating is based upon the reducer's ability to dissipate the heat caused by friction.

**Thermistors:** Are conductive ceramic materials, whose resistance remains relatively constant over a broad temperature range, then changes abruptly at a design threshold point, creating essentially a solid-state thermal switch. Attached control modules register this abrupt resistance change and produce an amplified output signal, usually a contact closure or fault trip annunciation. Thermistors are more accurate and faster responding than thermostats.

**Thermostat:** A protector, which is temperature-sensing only, that is mounted on the stator winding. Two leads from the device must be connected to a control circuit, which initiates corrective action. The customer must specify if the thermostats are to be normally closed or normally open.

**Thermocouple:** A pair of dissimilar conductors joined to produce a thermoelectric effect and used to accurately determine temperature. Thermocouples are used in laboratory testing of motors to determine the internal temperature of the motor winding.

**Thrust Load:** Force imposed on a shaft parallel to a shaft's axis. Thrust loads are often induced by the driven machine. Be sure the thrust load rating of a gear reducer is sufficient so that its shafts and bearings can absorb the load without premature failure.

**Torque:** The turning effort or force applied to a shaft, usually expressed in inch-pounds or inch-ounces for fractional and sub-fractional HP motors.

*Starting Torque:* Force produced by a motor as it begins to turn from standstill and accelerate (sometimes called locked rotor torque).

*Full-Load Torque:* The force produced by a motor running at rated full-load speed at rated horsepower.

*Breakdown Torque:* The maximum torque a motor will develop under increasing load conditions without an abrupt drop in speed and power. Sometimes called pull-out torque.

*Pull-Up Torque:* The minimum torque delivered by a motor between zero and the rated RPM, equal to the maximum load a motor can accelerate to rated RPM.

**Transformer:** Used to isolate line voltage from a circuit or to change voltage and current to lower or higher values. Constructed of primary and secondary windings around a common magnetic core.

**Underwriters Laboratories (UL):** Independent United States testing organization that sets safety standards for motors and other electrical equipment.

**Vector Drive:** An AC drive with enhanced processing capability that provides positioning accuracy and fast response to speed and torque changes. Often used with feedback devices in a closed-loop system.

**Voltage:** A unit of electromotive force that, when applied to conductors, will produce current in the conductors.

**Watt:** The amount of power required to maintain a current of 1 ampere at a pressure of one volt when the two are in phase with each other. One horsepower is equal to 746 watts.

**Winding:** Typically refers to the process of wrapping coils of copper wire around a core. In an AC induction motor, the primary winding is a stator consisting of wire coils inserted into slots within steel laminations. The secondary winding of an AC induction motor is usually not a winding at all, but rather a cast rotor assembly. In a permanent magnet DC motor, the winding is the rotating armature.



# IMPORTANT INFORMATION



## Please Read Carefully

This Basic Training Manual is not intended as a design guide for selecting and applying Marathon Motors electric motors, gear drive products, or adjustable frequency drives. It is intended as a general introduction to the concepts and terminology used with the products offered by Marathon Motors. Selection, application, and installation of Marathon Motors electric motors, gearmotors, and drives should be made by qualified personnel.

General Installation & Operating Instructions are provided with all Marathon Motors motors, gearmotors, and drives. These products should be installed and operated according to those instructions. Electrical connections should be made by a licensed electrician. Mechanical installation should be done by a mechanical contractor or maintenance engineer that is familiar with installing this type of equipment. Injury to personnel and/or premature, and possibly catastrophic, equipment failure may result from improper installation, maintenance, or operation.

Marathon Motors makes no warranties or representations, express or implied, by operation of law or otherwise, as to the merchantability or fitness for a particular purpose of the goods sold as a result of the use of this information. The Buyer acknowledges that it alone has determined that the goods purchased will suitably meet the requirements of their intended use. In no event will Marathon Motors be liable for consequential, incidental, or other damages the result from the proper or improper application of this equipment.







# marathon<sup>®</sup>

---

Motors



100 E. Randolph Street  
PO Box 8003  
Wausau, WI 54401-8003  
PH: 715-675-3311

[www.marathonelectric.com](http://www.marathonelectric.com)

A Regal Brand



[www.regalbeloit.com](http://www.regalbeloit.com)